

Synthesis of the Supremal Covert Attacker Against Unknown Supervisors by Using Observations

Ruo Chen Tai, Liyong Lin, Yuting Zhu and Rong Su

Abstract—In this paper, we consider the problem of synthesizing the supremal covert damage-reachable attacker, in the setup where the model of the supervisor is unknown to the adversary but the adversary has recorded a (prefix-closed) finite set of observations of the runs of the closed-loop system. The synthesized attacker needs to ensure both the damage-reachability and the covertness against all the supervisors which are consistent with the given set of observations. There is a gap between the de facto supremality, assuming the model of the supervisor is known, and the supremality that can be attained with a limited knowledge of the model of the supervisor, from the adversary’s point of view. We consider the setup where the attacker can exercise sensor replacement/deletion attacks and actuator enablement/disablement attacks. The solution methodology proposed in this work is to reduce the synthesis of the supremal covert damage-reachable attacker, given the model of the plant and the finite set of observations, to the synthesis of the supremal safe supervisor for certain transformed plant, which shows the decidability of the observation-assisted covert attacker synthesis problem. The effectiveness of our approach is illustrated on a water tank example adapted from the literature.

Index terms: Cyber-physical system, discrete-event system, covert attack, partial-observation, supervisor synthesis, learning, unknown model, supremality

I. INTRODUCTION

The security of cyber-physical system, modelled in the abstraction level of events [1], has attracted much research interest from the discrete-event system community, with most of the existing works devoted to attack detection and security verification [2]-[7], synthesis of attackers [8]-[18], and synthesis of resilient supervisors [16], [19]-[25].

The problem of covert sensor attacker synthesis has been studied extensively [8]-[10], [16], [17]. In [16], it is shown that, under a normality assumption on the sensor attackers, the supremal covert sensor attacker exists and can be effectively synthesized. In [8]-[10], a game-theoretic approach is presented to synthesize covert sensor attackers, without imposing the normality assumption. The problem of covert (sensor-)actuator attacker synthesis has been addressed in [11]-[15], by employing a reduction to the (partial-observation) supervisor synthesis problem. However, in all the previous works, it can be restrictive to assume the model of the supervisor to be known to the adversary, which is unlikely unless the adversary is an insider. Recently, we have considered a more practical setup where the model of the supervisor is not available to the adversary [26]. To compensate the lack of knowledge on the

model of the supervisor, it is assumed in [26] that the adversary has recorded a (prefix-closed) finite set of observations of the runs of the closed-loop system. In this more challenging setup, a covert attacker needs to be synthesized based solely on the model of the plant and the given set of observations. From the adversary’s point of view, any supervisor that is consistent with the given set of observations may have been deployed. And the synthesized attacker needs to ensure the damage-reachability and the covertness against all the supervisors that are consistent with the given set of observations. The difficulty of this synthesis problem lies in the fact that there can be in general an infinite number of supervisors which are consistent with the observations, rendering the synthesis approaches developed in the existing works ineffective. In [26], we have proposed a technique to compute covert damage-reachable attackers by formulating it as an instance of the supervisor synthesis problem on certain surrogate plant model, which is constructed without using the model of the supervisor. Due to the over-approximation in the surrogate plant model, the synthesized attacker in [26] cannot ensure the supremality in general. It is worth noting that there is a gap between the de facto supremality, assuming the model of the supervisor is known, and the supremality (from the adversary’s point of view) that could be attained with a limited knowledge of the model of the supervisor. It is the supremality from the adversary’s point of view that is of interest in this work.

In this paper, we also assume the model of the supervisor is not available to the adversary and the adversary can use the observations to assist the synthesis of covert attackers. The main contributions of this work are listed as follows.

- We provide a sound and complete procedure for the synthesis of covert damage-reachable attackers, given the model of the plant and the finite set of observations. The solution methodology is to reduce it to the problem of partial-observation supervisor synthesis for certain transformed plant, which shows the decidability of the observation-assisted covert (damage-reachable) attacker synthesis problem. We allow sensor replacement/deletion attacks¹ and actuator enablement/disablement attacks. In comparison, there are two limitations regarding the approach proposed in [26]: 1) it only provides a sound, but

¹It is also possible to deal with sensor insertion attacks by using our approach, which requires some modifications in our constructions, and the detailed model is given in [28]. The reason why we do not consider insertion attack is: In the standard DES under supervisory control, which is assumed to run strings of the form $(\Gamma(\Sigma - \Sigma_o)^*\Sigma_o)^*$, following Ramadge-Wonham framework, we know that any string that is not of this format immediately reveals the existence of an attacker and leads to the system halting, making the insertion attacks not useful for the standard DES. Naturally, sensor insertion attacks shall be allowed in practice, but the Ramadge-Wonham framework is an idealization of networked control systems (with zero delays) and makes the interpretation of sensor insertions attacks not that natural.

The research of the project was supported by Ministry of Education, Singapore, under grant AcRF TIER 1-2018-T1-001-245 (RG 91/18).

The authors are affiliated with Nanyang Technological University, Singapore. (Email: ruochen001@e.ntu.edu.sg; liyong.lin@ntu.edu.sg; yuting002@e.ntu.edu.sg; rsu@ntu.edu.sg). Ruo Chen Tai and Liyong Lin contribute equally to this work. (*Corresponding author: Liyong Lin*)

generally incomplete, heuristic algorithm for the synthesis of covert damage-reachable attackers due to the use of over-approximation in the surrogate plant, and 2) it cannot deal with actuator enablement attacks.

- The approach proposed in this work can synthesize the supremal covert damage-reachable attacker, among those attackers which can ensure the damage-reachability and the covertness against all the supervisors consistent with the set of observations, under the assumption $\Sigma_c \subseteq \Sigma_o$. We provide a formal proof of the supremality and the correctness of the synthesized attackers, by reasoning on the model of the attacked closed-loop system, adapted from [13], [14], [25]. In comparison, supremality is not guaranteed in [26], due to the use of over-approximation in the surrogate plant.

In practice, one may observe the closed-loop system for a sufficiently long time, i.e., obtain a sufficient number of observations of the runs of the closed-loop system, and hope to learn an exact observable model of the closed-loop system, that is, the natural projection of the closed-loop system, also known as the monitor [14]. However, this approach has two problems. First of all, it is not efficient, indeed infeasible, to learn the observable model of the closed-loop system, as in theory an infinite number of runs needs to be observed. We can never guarantee the correctness of the learnt model for any finite set of observations, without an oracle for confirming the correctness of the learnt model. Secondly, even if we obtain an exact observable model of the closed-loop system, the model in general has insufficient information for us to extract a model of the supervisor and use, for example, the technique developed in [12], [13] for synthesizing covert attackers. A much more viable and efficient approach is to observe the closed-loop system for just long enough, by observing as few runs of the closed-loop system as possible, to extract just enough information to carry out the synthesis of a non-empty covert attacker. If a given set of observations is verified to be sufficient for us to synthesize a non-empty covert attacker, then we know that more observations will only allow more permissive covert attacker to be synthesized. The solution proposed in this work can determine if any given set of observations contains enough information for the synthesis of a non-empty covert attacker and can directly synthesize a covert attacker from the set of observations whenever it is possible.

This paper is organized as follows. In Section II, we recall the preliminaries which are needed for understanding this paper. In Section III, we then introduce the system setup and present the model constructions. The proposed synthesis solution as well as the correctness proof are presented in Section IV. Finally, in Section V, the conclusions are drawn. A running example is given throughout the paper.

II. PRELIMINARIES

In this section, we introduce some basic notations and terminologies that will be used in this work, mostly following [1], [27], [29]. Given a finite alphabet Σ , let Σ^* be the free monoid over Σ with the empty string ε being the unit element. A language $L \subseteq \Sigma^*$ is a set of strings. The event

set Σ is partitioned into $\Sigma = \Sigma_c \dot{\cup} \Sigma_{uc} = \Sigma_o \dot{\cup} \Sigma_{uo}$, where Σ_c (respectively, Σ_o) and Σ_{uc} (respectively, Σ_{uo}) are defined as the sets of controllable (respectively, observable) and uncontrollable (respectively, unobservable) events, respectively. As usual, $P_o : \Sigma^* \rightarrow \Sigma_o^*$ is the natural projection defined as: 1) $P_o(\varepsilon) = \varepsilon$, 2) $(\forall \sigma \in \Sigma) P_o(\sigma) = \sigma$ if $\sigma \in \Sigma_o$, otherwise, $P_o(\sigma) = \varepsilon$, 3) $(\forall s\sigma \in \Sigma^*) P_o(s\sigma) = P_o(s)P_o(\sigma)$. We sometimes also write P_o as P_{Σ_o} , to explicitly illustrate the co-domain Σ_o^* .

A finite state automaton G over Σ is given by a 5-tuple $(Q, \Sigma, \xi, q_0, Q_m)$, where Q is the state set, $\xi : Q \times \Sigma \rightarrow Q$ is the (partial) transition function, $q_0 \in Q$ is the initial state, and Q_m is the set of marker states. We write $\xi(q, \sigma)!$ to mean that $\xi(q, \sigma)$ is defined. We define $En_G(q) = \{\sigma \in \Sigma \mid \xi(q, \sigma)!\}$. ξ is also extended to the (partial) transition function $\xi : Q \times \Sigma^* \rightarrow Q$ and the transition function $\xi : 2^Q \times \Sigma \rightarrow 2^Q$ [1], where the later is defined as follows: for any $Q' \subseteq Q$ and any $\sigma \in \Sigma$, $\xi(Q', \sigma) = \{q' \in Q \mid (\exists q \in Q') q' = \xi(q, \sigma)\}$. Let $L(G)$ and $L_m(G)$ denote the closed-behavior and the marked behavior, respectively. G is said to be marker-reachable if some marker state of G is reachable [1]. G is marker-reachable iff $L_m(G) \neq \emptyset$. When $Q_m = Q$, we shall also write $G = (Q, \Sigma, \xi, q_0)$ for simplicity. The ‘‘unobservable reach’’ of the state $q \in Q$ under the subset of events $\Sigma' \subseteq \Sigma$ is given by $UR_{G, \Sigma - \Sigma'}(q) := \{q' \in Q \mid (\exists s \in (\Sigma - \Sigma')^*) q' = \xi(q, s)\}$. We shall abuse the notation and define $P_{\Sigma'}(G)$ to be the finite state automaton $(2^Q - \{\emptyset\}, \Sigma, \delta, UR_{G, \Sigma - \Sigma'}(q_0))$ over Σ , where $UR_{G, \Sigma - \Sigma'}(q_0) \in 2^Q - \{\emptyset\}$ is the initial state, and the (partial) transition function $\delta : (2^Q - \{\emptyset\}) \times \Sigma \rightarrow (2^Q - \{\emptyset\})$ is defined as follows:

- (1) For any $\emptyset \neq Q' \subseteq Q$ and any $\sigma \in \Sigma'$, if $\xi(Q', \sigma) \neq \emptyset$, then $\delta(Q', \sigma) = UR_{G, \Sigma - \Sigma'}(\xi(Q', \sigma))$, where $UR_{G, \Sigma - \Sigma'}(Q'') = \bigcup_{q \in Q''} UR_{G, \Sigma - \Sigma'}(q)$ for any $\emptyset \neq Q'' \subseteq Q$.
- (2) For any $\emptyset \neq Q' \subseteq Q$ and any $\sigma \in \Sigma - \Sigma'$, $\delta(Q', \sigma) = Q'$.

We note that the construction of $P_{\Sigma'}(G)$ is equivalent to carrying out a chaining of natural projection, determinization and self-loops adding on G .

As usual, for any two finite state automata $G_1 = (Q_1, \Sigma_1, \xi_1, q_{1,0}, Q_{1,m})$ and $G_2 = (Q_2, \Sigma_2, \xi_2, q_{2,0}, Q_{2,m})$, where $En_{G_1}(q) = \{\sigma \in \Sigma_1 \mid \xi_1(q, \sigma)!\}$ and $En_{G_2}(q) = \{\sigma \in \Sigma_2 \mid \xi_2(q, \sigma)!\}$, their synchronous product [27] is denoted as $G_1 \parallel G_2 := (Q_1 \times Q_2, \Sigma_1 \cup \Sigma_2, \zeta, (q_{1,0}, q_{2,0}), Q_{1,m} \times Q_{2,m})$, where the (partial) transition function ζ is defined as follows, for any $(q_1, q_2) \in Q_1 \times Q_2$ and $\sigma \in \Sigma = \Sigma_1 \cup \Sigma_2$:

$$\zeta((q_1, q_2), \sigma) := \begin{cases} (\xi_1(q_1, \sigma), \xi_2(q_2, \sigma)) & \text{if } \sigma \in En_{G_1}(q_1) \cap En_{G_2}(q_2), \\ (\xi_1(q_1, \sigma), q_2) & \text{if } \sigma \in En_{G_1}(q_1) \setminus \Sigma_2, \\ (q_1, \xi_2(q_2, \sigma)) & \text{if } \sigma \in En_{G_2}(q_2) \setminus \Sigma_1, \\ \text{not defined} & \text{otherwise.} \end{cases}$$

For convenience, for any two finite state automata G_1 and G_2 , we write $G_1 = G_2$ iff $L(G_1) = L(G_2)$ and $L_m(G_1) = L_m(G_2)$. We also write $G_1 \sqsubseteq G_2$ iff $L(G_1) \subseteq L(G_2)$ and $L_m(G_1) \subseteq L_m(G_2)$. It then follows that $G_1 = G_2$ iff $G_1 \sqsubseteq G_2$ and $G_2 \sqsubseteq G_1$.

Notation. Let $\Gamma = \{\gamma \subseteq \Sigma \mid \Sigma_{uc} \subseteq \gamma\}$ denote the set

of all the possible control commands. In this work, it is assumed that when no control command is received by plant G , then only uncontrollable events could be executed. For a set Σ , we use $\Sigma^\#$ to denote a copy of Σ with superscript “#” attached to each element in Σ . Intuitively speaking, “#” denotes the message tampering due to the sensor attacks; the specific meanings of the relabelled events will be introduced later in Section III. Table I summarizes the notations of main components and symbols that would be adopted in this work.

TABLE I: NOTATIONS

Notation	Meaning
AC	Sensor attack constraints
\mathcal{A}	Sensor-actuator attacker
G	Plant
CE^A	Command execution under actuator attack
S	Supervisor
$BT(S)^A$	Bipartite supervisor under attack
NS	Supremal safe command non-deterministic supervisor
$OCNS^A$	Supremal safe and observation-consistent command non-deterministic supervisor under attack
S^\downarrow	The least permissive supervisor consistent with observations
$\overline{S^{\downarrow,A}}$	The least permissive supervisor consistent with observations under attack (a complete automaton)
$\Sigma_{s,a}$	the set of compromised observable events for the attacker
$\Sigma_{c,a}$	the set of actuator attackable events for the attacker
$\Sigma_{s,a}^\#$	the set of events of sending compromised events to the supervisor by the attacker

III. COMPONENT MODELS UNDER SENSOR-ACTUATOR ATTACK

In this section, we shall introduce the system architecture under sensor-actuator attack [14] and the model of each component. The system architecture is shown in Fig. 1, which consists of the following components:

- Plant G .
- Command execution CE^A under actuator attack.
- Sensor attack subject to sensor attack constraints AC .
- Unknown supervisor $BT(S)^A$ under attack (with an explicit control command sending phase).

In this work, we shall assume that $\Sigma_c \subseteq \Sigma_o$, which can be easily satisfied in reality. Generally speaking, the reason why we adopt this assumption is: Under this assumption, the least permissive supervisor that is consistent with the collected observations exists, and this is a critical point to prove the decidability of the problem studied in this work, which shall be analyzed later in Theorem IV.3-IV.8. Even if this assumption is

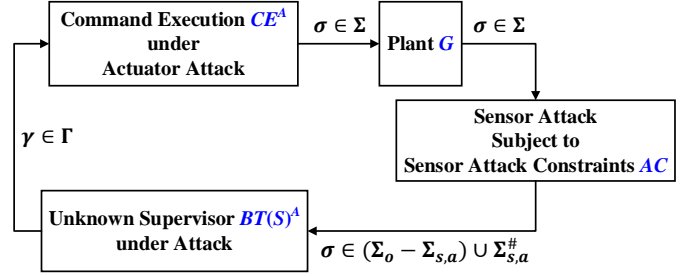

Fig. 1: System architecture under sensor-actuator attack

relaxed, the proposed synthesis algorithm is still guaranteed to be sound and it in general generates more permissive solutions than the heuristic algorithm proposed in [26], but it is then generally incomplete as well. For more details, the reader is referred to Remark IV.1 in Section IV. In the following, we explain how the models shown in the system architecture of Fig. 1 can be constructed.

A. Sensor attack constraints AC

In this work, the basic assumptions of the sensor attacker² is given as follows: 1) The sensor attacker can only observe the events in Σ_o , which is the set of observable events of the plant; the set of compromised observable events for the sensor attacker is denoted as $\Sigma_{s,a} \subseteq \Sigma_o$. 2) The sensor attacker can implement deletion or replacement attacks w.r.t. the events in $\Sigma_{s,a}$. 3) The sensor attack action (deletion or replacement) is instantaneous. When an attack is initiated for a specific observation, it will be completed before the next event can be executed by the plant G .

Briefly speaking, to encode the tampering effects of sensor attack on $\Sigma_{s,a}$, 1) We make a (relabelled) copy $\Sigma_{s,a}^\# = \{\sigma^\# | \sigma \in \Sigma_{s,a}\}$ of $\Sigma_{s,a} \subseteq \Sigma_o$ such that events in $\Sigma_{s,a}$ are executed by the plant, while events in $\Sigma_{s,a}^\#$ are those attacked copies sent by the sensor attacker and received by the supervisor. 2) Each transition labelled by $\sigma \in \Sigma_{s,a}$ in the bipartite supervisor is relabelled to $\sigma^\#$, in order to reflect the receiving of the attacked copy $\sigma^\#$ instead of σ . The above two techniques allow us to capture the effects of sensor attack.

Next, we shall introduce the model: sensor attack constraints, which serves as a “template” to describe the capabilities of the sensor attack. The sensor attack constraints is modelled as a finite state automaton AC , shown in Fig. 2³.

$$AC = (Q_{ac}, \Sigma_{ac}, \xi_{ac}, q_{ac}^{init})$$

- $Q_{ac} = \{q_{ac}^{init}, q_0, q_1\}$
- $\Sigma_{ac} = \Sigma \cup \Sigma_{s,a}^\# \cup \Gamma \cup \{stop\}$
- $\xi_{ac} : Q_{ac} \times \Sigma_{ac} \rightarrow Q_{ac}$

The (partial) transition function ξ_{ac} is defined as follows:

1. For any $\sigma \in \Sigma_{uo} \cup \Gamma$, $\xi_{ac}(q_{ac}^{init}, \sigma) = q_{ac}^{init}$. (occurrence of an unobservable event)

²We simply refer to the sensor attack decision making part of the sensor-actuator attacker as the sensor attacker.

³ Γ can be viewed as a set of events, where each $\gamma \in \Gamma$ denotes the event of sending (and receiving) the control command γ itself.

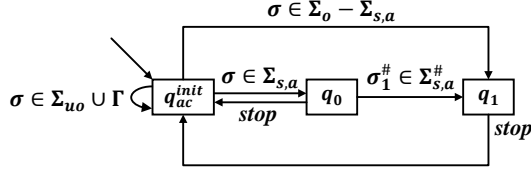

Fig. 2: The (schematic) model for sensor attack constraints AC

2. For any $\sigma \in \Sigma_{s,a}$, $\xi_{ac}(q_{ac}^{init}, \sigma) = q_0$. (observation of a compromised event)
3. For any $\sigma \in \Sigma_o - \Sigma_{s,a}$, $\xi_{ac}(q_{ac}^{init}, \sigma) = q_1$. (observation of an observable and non-compromised event)
4. For any $\sigma \in \Sigma_{s,a}$, $\xi_{ac}(q_0, \sigma^\#) = q_1$. (sensor replacement)
5. For any $n \in \{0, 1\}$, $\xi_{ac}(q_n, stop) = q_{ac}^{init}$. (end of attack)

We shall briefly explain the model AC . For the state set, the initial state q_{ac}^{init} denotes that the sensor attacker has not observed any event in Σ_o since the system initiation or the last attack operation. q_0 (q_1 , respectively) is a state denoting that the sensor attacker has observed some event in $\Sigma_{s,a}$ ($\Sigma_o - \Sigma_{s,a}$, respectively). For the event set, any event $\sigma^\#$ in $\Sigma_{s,a}^\#$ denotes an event of sending a compromised observable event σ to the supervisor by the sensor attacker. Thus, due to the existence of sensor attack, the supervisor can only observe the relabelled copy $\Sigma_{s,a}^\#$ instead of $\Sigma_{s,a}$. Any event $\gamma \in \Gamma$ denotes an event of sending a control command γ by the supervisor, which will be introduced later in Section III-D. The event $stop$ denotes the end of the current round of sensor attack operation. In this work, we shall treat any event in $\Sigma_o \cup \Sigma_{s,a}^\# \cup \{stop\}$ as being observable to the sensor attacker.

For the (partial) transition function ξ_{ac} ,

- Case 1 says that the occurrence of any event in $\Sigma_{uo} \cup \Gamma$, which is unobservable to the sensor attacker and cannot be attacked, would only lead to a self-loop at the state q_{ac}^{init} . The purpose of adding Case 1 is to ensure 1) the alphabet of AC is $\Sigma \cup \Sigma_{s,a}^\# \cup \Gamma \cup \{stop\}$, and 2) any event $\sigma \in \Sigma_{uo} \cup \Gamma$ is not defined at non- q_{ac}^{init} states and thus any event in Σ_o is immediately followed by an event in $\Sigma_{s,a}^\# \cup \{stop\}$ to simulate the immediate attack operation or the end of the attack operation following the observation of an event in Σ_o .
- Case 2 and Case 3 say that the observation of any event in $\Sigma_{s,a}$ ($\Sigma_o - \Sigma_{s,a}$, respectively) would lead to a transition to the state q_0 (q_1 , respectively), where the sensor attacker may perform some attack operations (cannot perform attack operations, respectively).
- Case 4 says that at the state q_0 , i.e., the sensor attacker has just observed some compromised observable event in $\Sigma_{s,a}$, it can implement sensor replacement attacks by replacing what it observes with any compromised observable event in $\Sigma_{s,a}$.
- Case 5 says that at the state q_0 or q_1 , the sensor attacker can end the current round of sensor attack operation. Since the supervisor could only observe its relabelled copy in $\Sigma_{s,a}^\#$ for any compromised event in $\Sigma_{s,a}$, after

observing an event in $\Sigma_{s,a}$, if the sensor attacker decides to end the current round of operation at state q_0 , denoted by $stop$, then it indeed implements the deletion attack.

Based on the model of AC , we know that $|Q_{ac}| = 3$.

B. Plant G

Plant is modelled by a finite state automaton $G = (Q, \Sigma, \xi, q^{init})$. We use $Q_d \subseteq Q$ to denote the set of bad (unsafe) states in G , which is the goal state set for the sensor-actuator attacker. We shall assume each state in Q_d is deadlocked, since damage cannot be undone⁴.

C. Command execution CE^A under actuator attack

In the supervisory control, the input to the plant is the control commands in Γ , while the output of the plant is the events in Σ . There is thus a “transduction” from the input $\gamma \in \Gamma$ of G to the output $\sigma \in \Sigma$ of G , which requires an automaton model over $\Sigma \cup \Gamma$ that describes the phase from using a control command to executing an event at the plant. This automaton model is referred to as the command execution automaton CE [12], [14], [30], which is given as follows:

$$CE = (Q_{ce}, \Sigma_{ce}, \xi_{ce}, q_{ce}^{init})$$

- $Q_{ce} = \{q^\gamma | \gamma \in \Gamma\} \cup \{q_{ce}^{init}\}$
- $\Sigma_{ce} = \Gamma \cup \Sigma$
- $\xi_{ce} : Q_{ce} \times \Sigma_{ce} \rightarrow Q_{ce}$

The (partial) transition function ξ_{ce} is defined as follows:

1. For any $\gamma \in \Gamma$, $\xi_{ce}(q_{ce}^{init}, \gamma) = q^\gamma$. (command reception)
2. For any $\sigma \in \gamma \cap \Sigma_{uo}$, $\xi_{ce}(q^\gamma, \sigma) = q^\gamma$. (unobservable event execution)
3. For any $\sigma \in \gamma \cap \Sigma_o$, $\xi_{ce}(q^\gamma, \sigma) = q_{ce}^{init}$. (observable event execution)

We shall briefly explain the model CE . For the state set, 1) q_{ce}^{init} is the initial state, denoting that CE is not using any control command; 2) q^γ is a state denoting that CE is using the control command γ . For the (partial) transition function ξ_{ce} , Case 1 says that once CE starts to use γ , it will transit to the state q^γ . Cases 2 and 3 say that at the state q^γ , the execution of any event in $\gamma \cap \Sigma_{uo}$ will lead to a self-loop, that is, γ will be reused, and the execution of any event in $\gamma \cap \Sigma_o$ will lead to the transition to the initial state, that is, CE will wait for the next control command to be issued from the supervisor. We note that only events of G can happen from q^γ in CE .

Next, we shall construct the command execution automaton under actuator attack, denoted as CE^A , where the superscript “ A ” indicates that this component is the version of command execution automaton which considers the effects of attack. The same naming rule in terms of the superscript would be adopted in the following text. In this work, we consider a class of actuator attackers that can implement both the enablement and disablement attacks, that is, the actuator attacker is capable of modifying the control command γ (issued by

⁴Since each state in Q_d is deadlocked, we can also merge these equivalent states into one deadlocked state.

the supervisor) by enabling or disabling some events in a specified attackable subset $\Sigma_{c,a} \subseteq \Sigma_c$, where Σ_c is the set of controllable events [12]. Then, based on CE , we shall encode the impacts of actuator attack on the event execution phase, and generate the command execution automaton CE^A under actuator attack [13], [14], which is shown in Fig. 3. Compared with CE , the changes are marked blue.

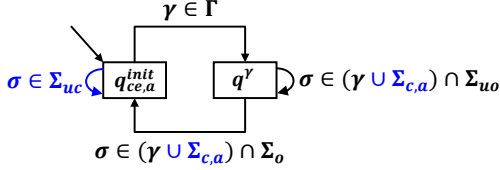

Fig. 3: The (schematic) model for command execution automaton CE^A under actuator attack

$$CE^A = (Q_{ce,a}, \Sigma_{ce,a}, \xi_{ce,a}, q_{ce,a}^{init})$$

- $Q_{ce,a} = Q_{ce}$
- $\Sigma_{ce,a} = \Sigma_{ce} = \Gamma \cup \Sigma$
- $\xi_{ce,a} : Q_{ce,a} \times \Sigma_{ce,a} \rightarrow Q_{ce,a}$
- $q_{ce,a}^{init} = q_{ce}^{init}$

The (partial) transition function $\xi_{ce,a}$ is defined as follows:

1. For any $q, q' \in Q_{ce,a}$ and any $\sigma \in \Sigma_{ce,a}$, $\xi_{ce}(q, \sigma) = q' \Rightarrow \xi_{ce,a}(q, \sigma) = q'$. (transitions retaining)
2. For any $q \in \{q^\gamma | \gamma \in \Gamma\}$ and any $\sigma \in \Sigma_{c,a} \cap \Sigma_{uo}$, $\xi_{ce,a}(q, \sigma) = q$. (attackable and unobservable event enablement)
3. For any $q \in \{q^\gamma | \gamma \in \Gamma\}$ and any $\sigma \in \Sigma_{c,a} \cap \Sigma_o$, $\xi_{ce,a}(q, \sigma) = q_{ce,a}^{init}$. (attackable and observable event enablement)
4. For any $\sigma \in \Sigma_{uc}$, $\xi_{ce}(q_{ce}^{init}, \sigma) = q_{ce}^{init}$. (uncontrollable event execution)

In the above definition of $\xi_{ce,a}$,

- Case 1 retains all the transitions defined in CE .
- Due to the existence of actuator attack, which can enable the events in $\Sigma_{c,a}$, in Case 2 and Case 3 we need to model the occurrences of any attackable event in $\Sigma_{c,a}$, where the execution of an unobservable event in $\Sigma_{c,a} \cap \Sigma_{uo}$ will lead to a self-loop and the execution of an observable event in $\Sigma_{c,a} \cap \Sigma_o$ will lead to the transition back to the initial state $q_{ce,a}^{init}$.
- In Case 4, we need to add the transitions labelled by the uncontrollable events at the initial state q_{ce}^{init} because the sensor attacker considered in this work can carry out sensor deletion attack on some compromised observable event in $\Sigma_{s,a}$, resulting in that the occurrence of this event cannot be observed by the supervisor and thus no control command is issued by the supervisor; in this case, although the command execution automaton receives no control command from the supervisor, it could still execute uncontrollable events, if they are defined at the current state of the plant G , since uncontrollable

events are always allowed to be fired⁵.

Here we remark that the actuator disablement would be automatically taken care of by the synthesis procedure in Section IV as the attackable event set $\Sigma_{c,a}$ is controllable by the actuator attacker, i.e., the actuator attack could always disable these events. Based on the model of CE^A , we know that $|Q_{ce,a}| = |\Gamma| + 1$.

Example III.1 We adapt the water tank example from [16] as a running example, whose schematic diagram is shown in Fig. 4. The system consists of a constant supply rate, a water tank, and a control valve at the bottom of the tank controlling the outgoing flow rate. We assume the valve can only be fully open or fully closed, resulting in the two events: *open* and *close*. The water level can be measured, whose value can trigger some predefined events that denote the water levels: low (*L*), high (*H*), extremely low (*EL*) and extremely high (*EH*). Our control goal is to adjust the control valve operation such that the water level would not be extremely low or extremely high. We assume all the events are observable, i.e., $\Sigma_o = \Sigma = \{L, H, EL, EH, close, open\}$. $\Sigma_{c,a} = \Sigma_c = \{close, open\}$. $\Sigma_{s,a} = \{L, H, EL, EH\}$. $\Gamma = \{v_1, v_2, v_3, v_4\}$. $v_1 = \{L, H, EL, EH\}$. $v_2 = \{close, L, H, EL, EH\}$. $v_3 = \{open, L, H, EL, EH\}$. $v_4 = \{close, open, L, H, EL, EH\}$. The model of the plant G (the state marked by red cross is the bad state), command execution automaton CE , command execution automaton CE^A under actuator attack, and the sensor attack constraints AC are shown in Fig. 5 - Fig. 7, respectively.

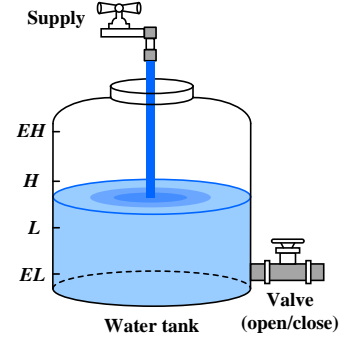

Fig. 4: The schematic diagram of the water tank operation scenario

D. Unknown supervisor $BT(S)^A$ under attack

In the absence of attacks, a supervisor S over the control constraint $\mathcal{C} = (\Sigma_c, \Sigma_o)$ is often modelled by a finite state automaton $S = (Q_s, \Sigma_s = \Sigma, \xi_s, q_s^{init})$, which satisfies the controllability and observability constraints [31]:

- (Controllability) For any state $q \in Q_s$ and any event $\sigma \in \Sigma_{uc}$, $\xi_s(q, \sigma)!$,

⁵For the model of CE , we do not need to add the self-loops labelled by the uncontrollable events at the initial state, since CE describes the execution model in the absence of attack. That is, once the plant fires an observable event, the supervisor will definitely observe the event and immediately issue a control command containing all the uncontrollable events.

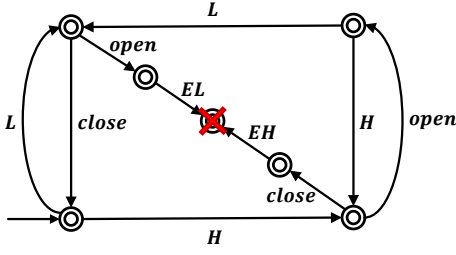
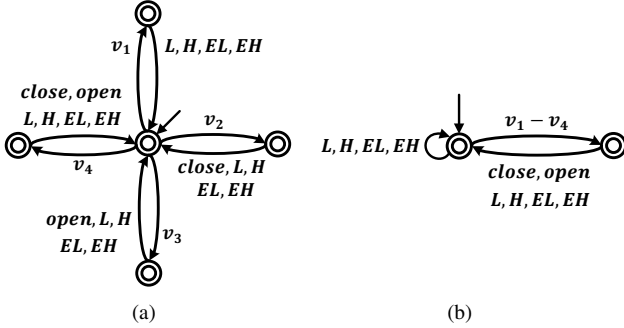
Fig. 5: Plant G Fig. 6: (a) Command execution automaton CE . (b) Command execution automaton CE^A under actuator attack (after automaton minimization), where $v_1 - v_4$ means v_1, v_2, v_3, v_4 .

- (Observability) For any state $q \in Q_s$ and any event $\sigma \in \Sigma_{uo}$, if $\xi_s(q, \sigma)!$, then $\xi_s(q, \sigma) = q$.

The control command issued by the supervisor S at state $q \in Q_s$ is defined to be $\Gamma(q) = En_S(q) = \{\sigma \in \Sigma \mid \xi_s(q, \sigma)!\}$. We assume the supervisor S will immediately issue a control command to the plant whenever an event $\sigma \in \Sigma_o$ is received or when the system initiates.

Based on the command execution automaton CE and the plant G , we shall notice that while CE can model the transduction from Γ to Σ , the transduction needs to be restricted by the behavior of G . Thus, only $CE \parallel G$ models the transduction from the input Γ of G to the output Σ of G . The diagram of the supervisory control feedback loop (in the absence of attack) can then be refined as in Fig. 8, where $BT(S)$, to be introduced shortly, is a control-equivalent bipartite⁶ supervisor to S and explicitly models the control command sending phase.

Next, we shall show how to model this bipartite supervisor $BT(S)$ based on S [12]. For any supervisor $S = (Q_s, \Sigma_s = \Sigma, \xi_s, q_s^{init})$, the procedure to construct $BT(S)$ is given as follows:

$$BT(S) = (Q_{bs}, \Sigma_{bs}, \xi_{bs}, q_{bs}^{init})$$

1. $Q_{bs} = Q_s \cup Q_s^{com}$, where $Q_s^{com} := \{q^{com} \mid q \in Q_s\}$
2. $\Sigma_{bs} = \Sigma \cup \Gamma$
3. a. $(\forall q^{com} \in Q_s^{com}) \xi_{bs}(q^{com}, \Gamma(q)) = q$. (command sending)

⁶Strictly speaking, $BT(S)$ is not bipartite as unobservable events in Σ_{uo} would lead to self-loops. In this work, for convenience, we shall always call supervisors with such structures bipartite ones.

Fig. 7: Sensor attack constraints AC 

Fig. 8: The refined diagram of the supervisory control feedback loop

- $(\forall q \in Q_s)(\forall \sigma \in \Sigma_{uo}) \xi_s(q, \sigma) \Rightarrow \xi_{bs}(q, \sigma) = \xi_s(q, \sigma) = q$. (occurrence of an unobservable event)
- $(\forall q \in Q_s)(\forall \sigma \in \Sigma_o) \xi_s(q, \sigma) \Rightarrow \xi_{bs}(q, \sigma) = (\xi_s(q, \sigma))^{com}$. (observation of an observable event)

4. $q_{bs}^{init} = (q_s^{init})^{com}$

We shall explain the above construction procedure. For the state set, we add Q_s^{com} , which is a relabelled copy of Q_s with the superscript “com” attached to each element of Q_s . Any state $q^{com} \in Q_s^{com}$ is a control state denoting that the supervisor is ready to issue the control command $\Gamma(q)$. Any state $q \in Q_s$ is a reaction state denoting that the supervisor is ready to react to an event $\sigma \in \Gamma(q)$. For the (partial) transition function ξ_{bs} , Step 3.a says that at any control state $q^{com} \in Q_s^{com}$, after issuing the control command $\Gamma(q)$, the supervisor would transit to the reaction state q . Step 3.b says that at any reaction state $q \in Q_s$, the occurrence of any unobservable event $\sigma \in \Sigma_{uo}$, if it is defined, would lead to a self-loop, i.e., the state still remains at the reaction state q . Step 3.c says that at any reaction state $q \in Q_s$, the occurrence of any observable event $\sigma \in \Sigma_o$, if it is defined, would lead to a transition to the control state $(\xi_s(q, \sigma))^{com}$. The initial state of $BT(S)$ is changed to the initial control state $(q_s^{init})^{com}$ which would issue the initial control command $\Gamma(q_s^{init})$ when the system initiates. Thus, if we abstract $BT(S)$ by merging the states x_{com} and x , treated as equivalent states, then we can recover S . In this sense, $BT(S)$ is control equivalent to S [14].

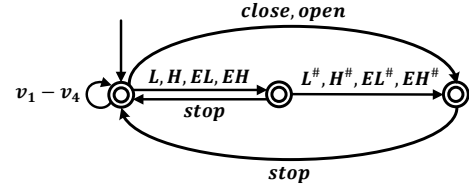
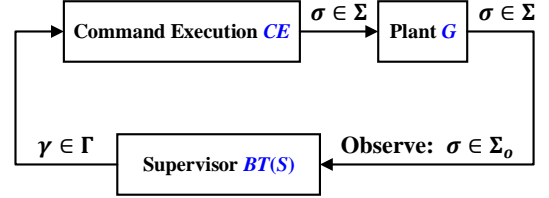
In this work, the model of the supervisor is unknown to the adversary, but we assume a safe supervisor has been implemented, that is, in $G \parallel CE \parallel BT(S)$, we assume no plant state in Q_d can be reached. Since the attacker can only observe events in Σ_o , the only prior knowledge available to the adversary is the model of the plant G and a set of observations $O \subseteq P_o(L(G \parallel CE \parallel BT(S)))$, where $P_o : (\Sigma \cup \Gamma)^* \rightarrow \Sigma_o^*$ (or $O \subseteq P_o(L(G \parallel S))$, where⁷ $P_o : \Sigma^* \rightarrow \Sigma_o^*$) [26] of the system

⁷We here abuse the notation P_o for two different natural projections from different domains. But it shall be clear which natural projection we refer to in each case.

executions under the unknown supervisor. The set of the attacker's observations O is captured by a finite state automaton $M_o = (Q_o, \Sigma_o, \xi_o, q_o^{init})$, i.e., $O = L(M_o)$. We refer to M_o as the observation automaton. Since O is finite, without loss of generality, we assume there is exactly one deadlocked state $q_o^{dl} \in Q_o$ in M_o and, for any maximal string $s \in O$ (in the prefix ordering [1]), we have $\xi_o(q_o^{init}, s) = q_o^{dl}$ [26]. Then, we have the following definition.

Definition III.1 (Consistency) Given the plant G , a supervisor S is said to be consistent with a set of observations O if $O \subseteq P_o(L(G||CE||BT(S)))$, where $P_o : (\Sigma \cup \Gamma)^* \rightarrow \Sigma_o^*$ (or $O \subseteq P_o(L(G||S))$, where $P_o : \Sigma^* \rightarrow \Sigma_o^*$).

Example III.2 We shall continue with the water tank example. We assume the attacker has collected a set of observations O , which is captured by M_o shown in Fig. 9.

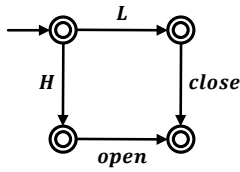

Fig. 9: Observations M_o

In this work, since we take the attack into consideration and aim to synthesize a covert sensor-actuator attacker against the unknown supervisor, we shall modify $BT(S)$ to generate a new bipartite supervisor $BT(S)^A$ under attack by modelling the effects of the sensor-actuator attack on the supervisor. The construction of $BT(S)^A$ consists of **Step 1** and **Step 2**:

Step 1: Firstly, in this work, we assume the monitoring [13] function is embedded into the supervisor, that is, the supervisor is able to compare its online observations of the system execution with the ones that can be observed in the absence of attack, and once some information inconsistency happens, the supervisor can assert the existence of an attacker and halts the system operation. To embed the monitoring mechanism into the supervisor in the absence of attack, we adopt what we refer to as the universal monitor $P_{\Sigma_o \cup \Gamma}(G||CE)$ to refine $BT(S)$ by synchronous product and obtain $BT(S)||P_{\Sigma_o \cup \Gamma}(G||CE)$. To see that $P_{\Sigma_o \cup \Gamma}(G||CE)$ is a universal monitor that works for any supervisor S , we perform the diagrammatic reasoning as follows (see Fig. 10).

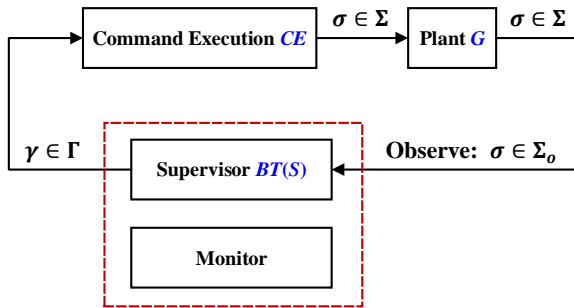

Fig. 10: The supervisory control feedback loop with an embedded monitor

1. Since the monitor observes the output and the input of the supervisor S , it can observe the events in $\Sigma_o \cup \Gamma$.
2. The model of the universal monitor is then exactly its observable model $P_{\Sigma_o \cup \Gamma}(G||CE)$ of everything that is external to S , i.e., $G||CE$.

We refer to $P_{\Sigma_o \cup \Gamma}(G||CE)$ as a universal monitor as it looks external against S and thus ignores the model of S ; intuitively, it is a monitor that works for any supervisor S . Then, when the monitoring mechanism is embedded into the supervisor, we simply refine the universal monitor $P_{\Sigma_o \cup \Gamma}(G||CE)$ with the supervisor model $BT(S)$ to obtain $BT(S)||P_{\Sigma_o \cup \Gamma}(G||CE)$. We record this automaton as $BT(S)^M$. Thus,

$$BT(S)^M = BT(S)||P_{\Sigma_o \cup \Gamma}(G||CE)$$

We denote $BT(S)^M = (Q_{bs,1}, \Sigma \cup \Gamma, \xi_{bs,1}, q_{bs,1}^{init})$. It is noteworthy that $BT(S)^M$ is bipartite as $BT(S)$ is bipartite. Thus, we could partition the state set $Q_{bs,1}$ into two parts, $Q_{bs,1} = Q_{bs,1}^{rea} \cup Q_{bs,1}^{com}$, where at any state of $Q_{bs,1}^{rea}$, only events in Σ are defined, and at any state of $Q_{bs,1}^{com}$, only events in Γ are defined. Then, we write

$$BT(S)^M = (Q_{bs,1}^{rea} \cup Q_{bs,1}^{com}, \Sigma \cup \Gamma, \xi_{bs,1}, q_{bs,1}^{init})$$

We have the following useful results.

Proposition III.1. $L(BT(S)^M||G||CE) = L(BT(S)||G||CE)$.

Proof: LHS = $L(BT(S)||P_{\Sigma_o \cup \Gamma}(G||CE)||G||CE) = L(BT(S)||G||CE) =$ RHS. ■

Corollary III.1. $O \subseteq P_o(L(BT(S)^M||G||CE))$.

Proof: This directly follows from **Proposition III.1** and the fact that $O \subseteq P_o(L(BT(S)||G||CE))$. ■

Proposition III.2. $BT(S)||P_{\Sigma_o \cup \Gamma}(G||CE)||BT(S) = BT(S)^M$.

Proof: It is clear that LHS = $BT(S)||P_{\Sigma_o \cup \Gamma}(G||CE)||BT(S) \sqsubseteq BT(S)||P_{\Sigma_o \cup \Gamma}(G||CE) =$ RHS. We have RHS = $BT(S)||P_{\Sigma_o \cup \Gamma}(G||CE) \sqsubseteq BT(S)||P_{\Sigma_o \cup \Gamma}(G||CE)||BT(S) =$ LHS, as the sequences in $P_{\Sigma_o \cup \Gamma}(G||CE)$ that can survive the synchronous product with $BT(S)$ must come from $P_{\Sigma_o \cup \Gamma}(G||CE)||BT(S)$. ■

Based on **Proposition III.2**, $BT(S)^M$ indeed embeds the monitor $P_{\Sigma_o \cup \Gamma}(G||CE)||BT(S)$ [13], which is adopted to detect the attacker by comparing the online observations with the ones that can be observed in the absence of attack.

Step 2: We shall encode the effects of the sensor-actuator attack into $BT(S)^M$ to generate $BT(S)^A$. The effects of the sensor-actuator attack include the following: 1) Due to the existence of the sensor attack, for any event $\sigma \in \Sigma_{s,a}$, the supervisor cannot observe it but can observe the relabelled copy $\sigma^\# \in \Sigma_{s,a}^\#$ instead, 2) Any event in $\Sigma_{c,a} \cap (\Sigma_{uo} \cup \Sigma_{s,a})$ might be enabled by the actuator attack and its occurrence is unobservable to the supervisor, and 3) the covertness-breaking situations can happen, i.e., information inconsistency between the online observations and the ones that can be observed in the absence of attack can happen. The construction procedure of $BT(S)^A$ is given as follows:

$$BT(S)^A = (Q_{bs,a}, \Sigma_{bs,a}, \xi_{bs,a}, q_{bs,a}^{init})$$

1. $Q_{bs,a} = Q_{bs,1} \cup \{q^{detect}\} = Q_{bs,1}^{rea} \cup Q_{bs,1}^{com} \cup \{q^{detect}\}$
 2. $\Sigma_{bs,a} = \Sigma \cup \Sigma_{s,a}^\# \cup \Gamma$
 3. a. $(\forall q, q' \in Q_{bs,1})(\forall \sigma \in \Sigma_{s,a}) \xi_{bs,1}(q, \sigma) = q' \Rightarrow \xi_{bs,a}(q, \sigma^\#) = q' \wedge \xi_{bs,a}(q, \sigma) = q$. (compromised event relabelling)
 - b. $(\forall q \in Q_{bs,1}^{rea})(\forall \sigma \in \Sigma_{c,a} \cap (\Sigma_{uo} \cup \Sigma_{s,a})) \xi_{bs,a}(q, \sigma) = q$. (occurrence of an attackable but unobservable event)
 - c. $(\forall q, q' \in Q_{bs,1})(\forall \sigma \in (\Sigma - \Sigma_{s,a}) \cup \Gamma) \xi_{bs,1}(q, \sigma) = q' \Rightarrow \xi_{bs,a}(q, \sigma) = q'$. (transitions retaining)
 - d. $(\forall q \in Q_{bs,1}^{rea})(\forall \sigma \in \Sigma_o - \Sigma_{s,a}) \neg \xi_{bs,1}(q, \sigma)! \Rightarrow \xi_{bs,a}(q, \sigma) = q^{detect}$. (covertness-breaking)
 - e. $(\forall q \in Q_{bs,1}^{rea})(\forall \sigma \in \Sigma_{s,a}) \neg \xi_{bs,1}(q, \sigma)! \Rightarrow \xi_{bs,a}(q, \sigma^\#) = q^{detect}$. (covertness-breaking)
4. $q_{bs,a}^{init} = q_{bs,1}^{init}$

We shall briefly explain the above procedure for constructing $BT(S)^A$. Firstly, at Step 1, all the states in $BT(S)^M$ are retained, and we add a new state q^{detect} into the state set to explicitly model that the presence of the attacker is detected. Then, for the (partial) transition function $\xi_{bs,a}$, at Step 3.a, we perform the following: 1) all the transitions labelled by events in $\Sigma_{s,a}$ are replaced with the copies in $\Sigma_{s,a}^\#$, denoted by $\xi_{bs,a}(q, \sigma^\#) = q'$, and 2) the transitions labelled by events in $\Sigma_{s,a}$ and originally defined in $BT(S)^M$ at state q would become self-loops since these events can be fired and are unobservable to the supervisor, denoted by $\xi_{bs,a}(q, \sigma) = q$. At Step 3.b, at any reaction state $q \in Q_{bs,1}^{rea}$, we shall add self-loop transitions labelled by the events in $\Sigma_{c,a} \cap (\Sigma_{uo} \cup \Sigma_{s,a})$ since such events can be enabled due to the actuator attack at the state q and are unobservable to the supervisor. At Step 3.c, all the other transitions, labelled by events in $(\Sigma - \Sigma_{s,a}) \cup \Gamma$, in $BT(S)^M$ are retained. Step 3.d and Step 3.e are defined to encode the covertness-breaking situations: at any reaction state $q \in Q_{bs,1}^{rea}$, for any observable event $\sigma \in \Sigma_o$, we add the transition, labelled by $\sigma \in \Sigma_o - \Sigma_{s,a}$ or the relabelled copy $\sigma^\# \in \Sigma_{s,a}^\#$, to the state q^{detect} if $\neg \xi_{bs,1}(q, \sigma)!$. Intuitively, the event σ should not be observed at the state q in the absence of attack⁸.

Based on the model of $BT(S)^A$, we know that $|Q_{bs,a}| \leq 2|Q_s| + 1$.

Example III.3 We shall continue with the water tank example. For a supervisor S shown in Fig. 11. (a), the step-by-step constructed $BT(S)$, $BT(S)^M$, and $BT(S)^A$ are illustrated in Fig. 11. (b), (c), (d), respectively. Specifically, the detailed construction procedure of $BT(S)$ for the supervisor S given in Fig. 11. (a) (also Fig. 12. (i)) is presented as follows:

1. Firstly, since the state set of S is $Q_s = \{0\}$, based on Step 1 in the construction of $BT(S)$, we have $Q_{bs} = Q_s \cup Q_s^{com} = \{0^{com}, 0\}$, where the state 0^{com} is the initial state of $BT(S)$ according to Step 4. The generated state set of $BT(S)$ is shown in Fig. 12. (ii).
2. Secondly, based on Step 3.a and the fact that $\Gamma(0) = \{L, H, EL, EH\} = v_1$, we have $\xi_{bs}(0^{com}, \Gamma(0) = v_1) =$

⁸To the supervisor, once an event $\sigma^\# \in \Sigma_{s,a}^\#$ is observed, which is issued by the attacker, the supervisor believes that the event $\sigma \in \Sigma_{s,a}$ has been executed in the plant. This is the reason why we relabel $\Sigma_{s,a}$ to $\Sigma_{s,a}^\#$ in the supervisor model and this does not change its control function.

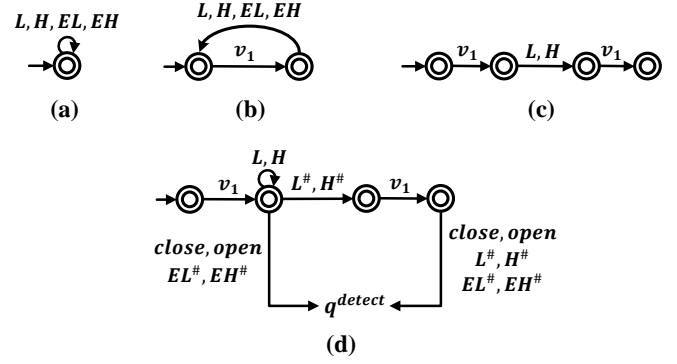

Fig. 11: (a) S . (b) $BT(S)$. (c) $BT(S)^M$. (d) $BT(S)^A$.

0, which is shown by the added transition in Fig. 12. (iii).

3. Finally, based on Step 3.c, since $\xi_s(0, L)!$ and $\xi_s(0, L) = 0$, we have $\xi_{bs}(0, L) = (\xi_s(0, L))^{com} = 0^{com}$, which is shown by the added transition in Fig. 12. (iv). Similarly, we could generate the transitions labelled as H , EL and EH from state 0 to state 0^{com} .

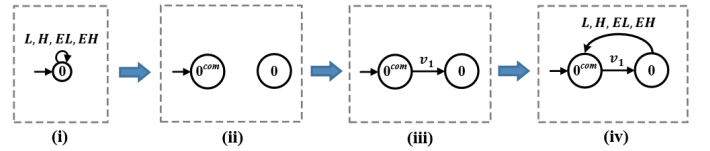

Fig. 12: The construction procedure of $BT(S)$ based on S . (i) is S and (iv) is $BT(S)$.

E. Sensor-actuator attacker

The sensor-actuator attacker is modelled by a finite state automaton $\mathcal{A} = (Q_a, \Sigma_a, \xi_a, q_a^{init})$, where $\Sigma_a = \Sigma \cup \Sigma_{s,a}^\# \cup \Gamma \cup \{stop\}$. In addition, there are two conditions that need to be satisfied:

- (A-controllability) For any state $q \in Q_a$ and any event $\sigma \in \Sigma_{a,uc} := \Sigma_a - (\Sigma_{c,a} \cup \Sigma_{s,a}^\# \cup \{stop\})$, $\xi_a(q, \sigma)!$
- (A-observability) For any state $q \in Q_a$ and any event $\sigma \in \Sigma_{a,uo} := \Sigma_a - (\Sigma_o \cup \Sigma_{s,a}^\# \cup \{stop\})$, if $\xi_a(q, \sigma)!$, then $\xi_a(q, \sigma) = q$.

A-controllability states that the sensor-actuator attacker can only disable events in $\Sigma_{c,a} \cup \Sigma_{s,a}^\# \cup \{stop\}$. A-observability states that the sensor-actuator attacker can only make a state change after observing an event in $\Sigma_o \cup \Sigma_{s,a}^\# \cup \{stop\}$. In the following text, we shall refer to

$$\mathcal{C}_{ac} = (\Sigma_{c,a} \cup \Sigma_{s,a}^\# \cup \{stop\}, \Sigma_o \cup \Sigma_{s,a}^\# \cup \{stop\})$$

as the attacker's control constraint, and $(\Sigma_o, \Sigma_{s,a}, \Sigma_{c,a})$ as the attack constraint. It is apparent that the attacker's control constraint \mathcal{C}_{ac} is uniquely determined by the attack constraint $(\Sigma_o, \Sigma_{s,a}, \Sigma_{c,a})$. Based on the assumption $\Sigma_c \subseteq \Sigma_o$, we have $\Sigma_{c,a} \cup \Sigma_{s,a}^\# \cup \{stop\} \subseteq \Sigma_o \cup \Sigma_{s,a}^\# \cup \{stop\}$, implying the supremality of the sensor-actuator attacker.

IV. SYNTHESIS OF SUPREMAL COVERT ATTACKERS AGAINST UNKNOWN SUPERVISORS

In this section, we shall present the solution methodology for the synthesis of the supremal covert sensor-actuator attacker against unknown (safe) supervisors by using observations. Firstly, in this work, since we focus on the synthesis of sensor-actuator attacker that aims to cause damage-infliction, we shall denote the marker state set of G as Q_d , and still denote the modified automaton as $G = (Q, \Sigma, \xi, q^{init}, Q_d)$ in the following text. Then, based on the above-constructed component models in Section III, we know that, given any plant G , command execution automaton CE^A under actuator attack, sensor attack constraints AC , sensor-actuator attacker \mathcal{A} , bipartite supervisor $BT(S)^A$ under attack⁹, the closed-loop behavior is (cf. Fig. 1)

$$\mathcal{B} = G||CE^A||AC||BT(S)^A||\mathcal{A} = (Q_b, \Sigma_b, \xi_b, q_b^{init}, Q_{b,m})$$

- $Q_b = Q \times Q_{ce,a} \times Q_{ac} \times Q_{bs,a} \times Q_a$
- $\Sigma_b = \Sigma \cup \Sigma_{s,a}^\# \cup \Gamma \cup \{stop\}$
- $\xi_b : Q_b \times \Sigma_b \rightarrow Q_b$
- $q_b^{init} = (q^{init}, q_{ce,a}^{init}, q_{ac}^{init}, q_{bs,a}^{init}, q_a^{init})$
- $Q_{b,m} = Q_d \times Q_{ce,a} \times Q_{ac} \times Q_{bs,a} \times Q_a$

Then, we have the following definitions [14].

Definition IV.1 (Covertness) Given any plant G , command execution automaton CE^A under actuator attack, sensor attack constraints AC , and bipartite supervisor $BT(S)^A$ under attack, the sensor-actuator attacker \mathcal{A} is said to be covert against the supervisor S w.r.t. the attack constraint $(\Sigma_o, \Sigma_{s,a}, \Sigma_{c,a})$ if any state in

$$Q_{bad} = \{(q, q_{ce,a}, q_{ac}, q_{bs,a}, q_a) \in Q_b \mid q \notin Q_d \wedge q_{bs,a} = q^{detect}\}$$

is not reachable in \mathcal{B} .

Definition IV.2 (Damage-reachable) Given any plant G , command execution automaton CE^A under actuator attack, sensor attack constraints AC , and bipartite supervisor $BT(S)^A$ under attack, the sensor-actuator attacker \mathcal{A} is said to be damage-reachable against the supervisor S w.r.t. the attack constraint $(\Sigma_o, \Sigma_{s,a}, \Sigma_{c,a})$ if some marker state in $Q_{b,m}$ is reachable in \mathcal{B} , that is, $L_m(\mathcal{B}) \neq \emptyset$.

Definition IV.3 (Successful) Given any plant G , a set of observations O , and the attack constraint $(\Sigma_o, \Sigma_{s,a}, \Sigma_{c,a})$, a sensor-actuator attacker \mathcal{A} is said to be successful if it is covert and damage-reachable against any safe supervisor that is consistent with O .

Definition IV.4 (Supremality) Given any plant G , a set of observations O , and the attack constraint $(\Sigma_o, \Sigma_{s,a}, \Sigma_{c,a})$, a successful sensor-actuator attacker \mathcal{A} is said to be supremal if for any other successful sensor-actuator attacker \mathcal{A}' , we have $L(G||CE^A||AC||BT(S)^A||\mathcal{A}') \subseteq L(G||CE^A||AC||BT(S)^A||\mathcal{A})$, for any safe supervisor S that is consistent with O .

⁹To be precise, $BT(S)^A$ is not an attacked supervisor as it also embeds the model of the attacked monitor.

Remark IV.1 If $L(G||CE^A||AC||BT(S)^A||\mathcal{A}') \subseteq L(G||CE^A||AC||BT(S)^A||\mathcal{A})$, then we have

$$\begin{aligned} & L_m(G||CE^A||AC||BT(S)^A||\mathcal{A}') \\ &= L(G||CE^A||AC||BT(S)^A||\mathcal{A}')||L_m(G) \\ &\subseteq L(G||CE^A||AC||BT(S)^A||\mathcal{A})||L_m(G) \\ &= L_m(G||CE^A||AC||BT(S)^A||\mathcal{A}) \end{aligned}$$

Based on the above definitions, the observation-assisted covert attacker synthesis problem to be solved in this work is formulated as follows:

Problem 1: Given the plant G , a set of observations O and the attack constraint $(\Sigma_o, \Sigma_{s,a}, \Sigma_{c,a})$, synthesize the supremal successful, i.e., covert and damage-reachable, sensor-actuator attacker?

Next, we shall present our solution methodology for **Problem 1**.

A. Main idea

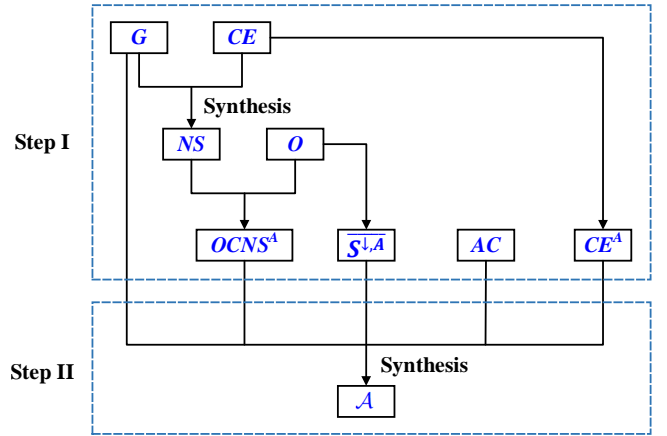

Fig. 13: The procedure of the proposed solution methodology

Before we delve into the detailed solution methodology which will be presented in Section IV-B, the high-level idea of our method shown in Fig. 13 is explained in the following. We perform the chaining of two synthesis constructions, in order to synthesize the supremal covert damage-reachable sensor-actuator attacker, assisted with the finite set of observations O .

1. At the first step, based on the plant G and the command execution automaton CE , we shall synthesize NS , the supremal safe command non-deterministic supervisor [30], [32] that embeds all the safe partial-observation supervisors in the sense of [33], by using the normality property based synthesis [1], [30], [32], [34]. Then, by using the observations O , we perform a direct pruning and attack modelling on the synthesized command non-deterministic supervisor NS to obtain $OCNS^A$, the supremal safe and observation-consistent command non-deterministic supervisor under sensor-actuator attack. The covertness-breaking states will be encoded in $OCNS^A$. In addition, based on the observations O , we shall construct S^A , whose marked behavior encodes the least permissive supervisor

(that is consistent with O) under attack, to make sure that the synthesized sensor-actuator attacker is damage-reachable against any safe supervisor that is consistent with the observations [26].

2. At the second step, based on G , $OCNS^A$, $\overline{S^{\downarrow,A}}$, AC , and CE^A , we can employ techniques similar to those of [13], [14] to reduce the synthesis of the supremal covert damage-reachable attacker to the synthesis of the supremal safe partial-observation supervisor.

In particular, the model of the unknown supervisor S is not needed for the above constructions. Intuitively speaking, the synthesized attacker \mathcal{A} ensures covertness and damage-reachability because of the following reasons:

- It ensures covertness against all the safe supervisors which are consistent with the observations, since it already ensures covertness against $OCNS^A$, the supremal safe and observation-consistent command non-deterministic supervisor (under attack), which embeds all the possible safe (partial-observation) supervisors that are consistent with the observations.
- It ensures the damage-reachability against all the supervisors that are consistent with the observations, since it already ensures damage-reachability against $S^{\downarrow,A}$ [26], which induces the smallest marked behavior.

It follows that we can use the many tools and techniques [35] - [37] that have been developed for the synthesis of the supremal partial-observation supervisor to synthesize the supremal covert damage-reachable attacker assisted with the observations.

B. Solution methodology

Step 1: Construction of NS

Firstly, we shall synthesize NS , the supremal safe command non-deterministic supervisor¹⁰. The procedure is given as follows:

Procedure 1:

1. Compute $\mathcal{P} = G||CE = (Q_{\mathcal{P}}, \Sigma_{\mathcal{P}} = \Sigma \cup \Gamma, \xi_{\mathcal{P}}, q_{\mathcal{P}}^{init})$ ¹¹.
2. Generate $\mathcal{P}_r = (Q_{\mathcal{P}_r}, \Sigma_{\mathcal{P}_r}, \xi_{\mathcal{P}_r}, q_{\mathcal{P}_r}^{init})$
 - $Q_{\mathcal{P}_r} = Q_{\mathcal{P}} - \{(q, q_{ce}) \in Q_{\mathcal{P}} | q \in Q_d\}$
 - $\Sigma_{\mathcal{P}_r} = \Sigma_{\mathcal{P}} = \Sigma \cup \Gamma$
 - $(\forall q, q' \in Q_{\mathcal{P}_r})(\forall \sigma \in \Sigma_{\mathcal{P}_r}) \xi_{\mathcal{P}}(q, \sigma) = q' \Leftrightarrow \xi_{\mathcal{P}_r}(q, \sigma) = q'$
 - $q_{\mathcal{P}_r}^{init} = q_{\mathcal{P}}^{init}$
3. Synthesize the supremal supervisor $NS = (Q_{ns}, \Sigma_{ns} = \Sigma \cup \Gamma, \xi_{ns}, q_{ns}^{init})$ over the control constraint $(\Gamma - \{\Sigma_{uc}\}, \Sigma_o \cup \Gamma)$ by treating \mathcal{P} as the plant and \mathcal{P}_r as the requirement such that $\mathcal{P}||NS$ is safe w.r.t. \mathcal{P}_r .

We shall briefly explain **Procedure 1**. As illustrated in Fig. 8, at Step 1, we shall construct a lifted plant $\mathcal{P} = G||CE$,

¹⁰We can refer to Fig. 8. Instead of employing a command deterministic supervisor $BT(S)$ (to control $G||CE$), which issues a unique control command at each control state, we can employ NS for the control of $G||CE$. In particular, NS has the choice of issuing different control commands at each control state.

¹¹By definition, the marker state set of \mathcal{P} should be $Q_d \times Q_{ce}$, but here, we shall mark all the states of \mathcal{P} since we only care about safe supervisors.

where the issuing of different control commands is modelled and can be controlled. In addition, since we only consider safe supervisors, at Step 2, we shall then remove any state of $\{(q, q_{ce}) \in Q_{\mathcal{P}} | q \in Q_d\}$ in \mathcal{P} to generate the requirement \mathcal{P}_r . Thus, by treating \mathcal{P} as the plant and \mathcal{P}_r as the requirement, we can synthesize the supremal safe command-nondeterministic supervisor NS over the control constraint $(\Gamma - \{\Sigma_{uc}\}, \Sigma_o \cup \Gamma)$, whose existence is guaranteed since $\Gamma - \{\Sigma_{uc}\} \subseteq \Sigma_o \cup \Gamma$ [1], [21], [30], [32]. Here, the control command Σ_{uc} is not controllable to the supervisor because it entirely consists of uncontrollable events, which are always allowed to be fired at the plant G . We note that NS is a deterministic automaton, but command non-deterministic in the sense that at each control state, more than two different control commands may be issued.

Based on the structure of G and CE , the synthesized NS is a bipartite structure (introduced in Section III-D). For technical convenience, we shall write the state set of NS as $Q_{ns} = Q_{ns}^{rea} \cup Q_{ns}^{com}$ (Q_{ns}^{rea} and Q_{ns}^{com} denote the set of reaction states and control states, respectively), where

- At any state of Q_{ns}^{rea} , any event in Γ is not defined.
- At any state of Q_{ns}^{rea} , any event in Σ_{uo} , if defined, leads to self-loops, and any event in Σ_o , if defined, would lead to a transition to a control state.
- At any state of Q_{ns}^{com} , only events in Γ are defined.
- At any state of Q_{ns}^{com} , any event in Γ , if defined, would lead to a transition to a reaction state.

We shall briefly explain why these 4 cases hold. We know that: 1) since the closed-behavior of \mathcal{P} is a subset of $(\Gamma(\Sigma - \Sigma_o)^*\Sigma_o)^*$, the closed-behavior of NS is also a subset of $(\Gamma(\Sigma - \Sigma_o)^*\Sigma_o)^*$, 2) any transition labelled as an unobservable event in $\Sigma - \Sigma_o$ would be a self-loop in NS while any transition labelled as an event in $\Sigma_o \cup \Gamma$ would enable NS to make a state transition. Thus, we could always divide the state set of NS into two disjoint parts: 1) the set of control states Q_{ns}^{com} , where only the control commands in Γ are defined (Case 3), 2) the set of reaction states Q_{ns}^{rea} , where any event in Γ is not defined (Case 1) and the events, if defined at such a state, belong to Σ . In addition, based on the format of closed-behavior of \mathcal{P} , Case 2 and Case 4 naturally hold. Based on **Procedure 1**, we know that $|Q_{ns}| \leq 2^{|Q| \times |Q_{ce}|}$.

Example IV.1 We shall continue with the water tank example, whose setup is shown in **Example III.1**. Based on the plant G and command execution automaton CE illustrated in Fig. 5 and Fig. 6, respectively, the synthesized supremal safe command-nondeterministic supervisor NS is illustrated in Fig. 14. At the initial state 0 of NS , it could issue any control command in $v_1 = \{L, H, EL, EH\}$, $v_2 = \{close, L, H, EL, EH\}$, $v_3 = \{open, L, H, EL, EH\}$, $v_4 = \{close, open, L, H, EL, EH\}$, after which it would transit to state 1. Then, after the plant G receives the control command issued from the supervisor at the initial state, it would always execute the event L or H no matter which control command it receives. Next, there are two cases:

1. If NS receives the observation L , it would transit to state 2, at which it could issue the control command v_1 or v_2 . If it issues v_1 and transits to state 6, then G would not execute

- any event under v_1 as v_1 does not contain any event that could be executed w.r.t. the state of G , thus, no event occurs at state 6 of NS ; otherwise, i.e., if it issues v_2 and transits to state 4, then G would execute the event $close$. After NS receives the observation $close$, it would transit to state 0, at which any control command of $v_1 - v_4$ could be issued.
2. If NS receives the observation H , it would transit to state 3, at which it could issue the control command v_1 or v_2 . If it issues v_1 and transits to state 6, then G would not execute any event under v_1 as v_1 does not contain any event that could be executed w.r.t. the state of G , thus, no event occurs at state 6 of NS ; otherwise, i.e., if it issues v_3 and transits to state 5, then G would execute the event $open$. After NS receives the observation $open$, it would transit to state 0, at which any control command of $v_1 - v_4$ could be issued.

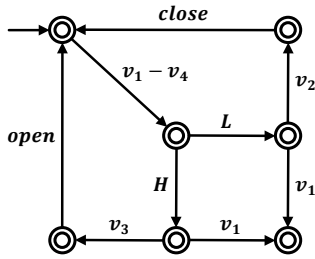

Fig. 14: The synthesized supremal safe command-nondeterministic supervisor NS

Step 2: Construction of $OCNS^A$

Next, as stated in the main idea of Section IV-A, based on the synthesized NS and observations O , we shall construct $OCNS^A$, which encodes the supremal safe and observation-consistent command non-deterministic supervisor under sensor-actuator attack. The step-by-step construction procedure is given as follows, including **Step 2.1** - **Step 2.3**.

Step 2.1: Construction of OC

Based on $M_o = (Q_o, \Sigma_o, \xi_o, q_o^{init})$ which captures the observations O , we shall construct a bipartite structure OC to embed all the supervisors consistent with O . The construction of OC is similar to that of a bipartite supervisor $BT(S)$ shown in Section III-D, which is given as follows:

$$OC = (Q_{oc}, \Sigma_{oc}, \xi_{oc}, q_{oc}^{init})$$

1. $Q_{oc} = Q_o \cup Q_o^{com} \cup \{q_{oc}^{dump}\}$, where $Q_o^{com} := \{q^{com} | q \in Q_o\}$
2. $\Sigma_{oc} = \Sigma \cup \Gamma$
3. $(\forall q^{com} \in Q_o^{com})(\forall \gamma \in \Gamma) En_{M_o}(q) \subseteq \gamma \Rightarrow \xi_{oc}(q^{com}, \gamma) = q$. (ensure the command consistency with observations)
4. $(\forall q \in Q_o)(\forall \sigma \in \Sigma_o) \xi_o(q, \sigma)! \Rightarrow \xi_{oc}(q, \sigma) = (\xi_o(q, \sigma))^{com}$. (observation of an observable event consistent with observations)
5. $(\forall q \in Q_o)(\forall \sigma \in \Sigma_o) \neg \xi_o(q, \sigma)! \Rightarrow \xi_{oc}(q, \sigma) = q_{oc}^{dump}$. (observation of an observable event inconsistent with observations)

6. $(\forall q \in Q_o)(\forall \sigma \in \Sigma_{uo}) \xi_{oc}(q, \sigma) = q$. (occurrence of an unobservable event)
7. $(\forall \sigma \in \Sigma \cup \Gamma) \xi_{oc}(q_{oc}^{dump}, \sigma) = q_{oc}^{dump}$.
8. $q_{oc}^{init} = (q_o^{init})^{com}$

Firstly, at Step 1, the state set Q_{oc} consists of the reaction state set Q_o and the control state set Q_o^{com} . In addition, we add a new state q_{oc}^{dump} to denote that some event sequence which is not collected in the observations O happens. At Step 3, for any control state q^{com} , we shall allow the issuing of any control command γ satisfying the condition $En_{M_o}(q) \subseteq \gamma$, i.e., γ can generate the event executions $En_{M_o}(q)$ that have been collected at the state q . At Step 4, all the transitions originally defined at the state q in M_o are retained and would drive the state change to the control state $(\xi_o(q, \sigma))^{com}$. At Step 5, for any reaction state q , any event in Σ_o , which has not been collected in the current observations, would lead to a transition to the dump state q_{oc}^{dump} . At Step 6, at any reaction state, all the events in Σ_{uo} will lead to self-loops because they are unobservable. At Step 7, any event in $\Sigma \cup \Gamma$ is defined at the state q_{oc}^{dump} since q_{oc}^{dump} is a state denoting that the transition has gone out of the observations collected by the attacker, implying that any event in $\Sigma \cup \Gamma$ might happen.

Step 2.2: Construction of $OCNS$

Although OC embeds all the supervisors consistent with O , we need to ensure they are safe supervisors. Thus, we shall adopt the above-synthesized $NS = (Q_{ns}^{rea} \cup Q_{ns}^{com}, \Sigma_{ns} = \Sigma \cup \Gamma, \xi_{ns}, q_{ns}^{init})$, which encodes all the possible safe bipartite supervisors, to refine the structure of OC . To achieve this goal, we compute the synchronous product $OCNS = NS || OC = (Q_{ocns}, \Sigma_{ocns}, \xi_{ocns}, q_{ocns}^{init})$, where it can be easily checked that $Q_{ocns} \subseteq (Q_{ns}^{rea} \times (Q_o \cup \{q_{oc}^{dump}\})) \cup (Q_{ns}^{com} \times (Q_o^{com} \cup \{q_{oc}^{dump}\}))$. We shall refer to $OCNS$ as the observation consistent command non-deterministic supervisor.

Step 2.3: Construction of $OCNS^A$

Based on $OCNS$, we shall encode the effects of the sensor-actuator attacks to generate $OCNS^A$, which is similar to the construction procedure of $BT(S)^A$ given in **Step 2** of Section III-D.

$$OCNS^A = (Q_{ocns}^a, \Sigma_{ocns}^a, \xi_{ocns}^a, q_{ocns}^{init,a})$$

1. $Q_{ocns}^a = Q_{ocns} \cup \{q_{cov}^{brk}\}$
2. $\Sigma_{ocns}^a = \Sigma \cup \Sigma_{s,a}^\# \cup \Gamma$
3. $(\forall q, q' \in Q_{ocns}^a)(\forall \sigma \in \Sigma_{s,a}) \xi_{ocns}(q, \sigma) = q' \Rightarrow \xi_{ocns}^a(q, \sigma^\#) = q' \wedge \xi_{ocns}^a(q, \sigma) = q$
4. $(\forall q \in Q_{ocns}^a)(\forall \sigma \in \Sigma_{c,a} \cap (\Sigma_{uo} \cup \Sigma_{s,a})) q \in Q_{ns}^{rea} \times (Q_o \cup \{q_{oc}^{dump}\}) \Rightarrow \xi_{ocns}^a(q, \sigma) = q$
5. $(\forall q, q' \in Q_{ocns}^a)(\forall \sigma \in (\Sigma - \Sigma_{s,a}) \cup \Gamma) \xi_{ocns}(q, \sigma) = q' \Rightarrow \xi_{ocns}^a(q, \sigma) = q'$
6. $(\forall q \in Q_{ocns}^a)(\forall \sigma \in \Sigma_o - \Sigma_{s,a}) q \in Q_{ns}^{rea} \times (Q_o \cup \{q_{oc}^{dump}\}) \wedge \neg \xi_{ocns}(q, \sigma)! \Rightarrow \xi_{ocns}^a(q, \sigma) = q_{cov}^{brk}$
7. $(\forall q \in Q_{ocns}^a)(\forall \sigma \in \Sigma_{s,a}) q \in Q_{ns}^{rea} \times (Q_o \cup \{q_{oc}^{dump}\}) \wedge \neg \xi_{ocns}(q, \sigma)! \Rightarrow \xi_{ocns}^a(q, \sigma^\#) = q_{cov}^{brk}$
8. $q_{ocns}^{init,a} = q_{ocns}^{init}$

At Step 1, all the states in $OCNS$ are retained, and we shall add a new state q_{cov}^{brk} to denote the covertness-breaking

situations. At Step 3, due to the existence of sensor attack, at any state q , any transition labelled by $\sigma \in \Sigma_{s,a}$ in $OCNS$ is relabelled with $\sigma^\# \in \Sigma_{s,a}^\#$ because the supervisor can observe $\Sigma_{s,a}^\#$ instead of $\Sigma_{s,a}$; in addition, a self-loop labelled by σ is added at the state q because such event can happen and is unobservable to the supervisor. At Step 4, for any state $q \in Q_{ns}^{rea} \times (Q_o \cup \{q_{oc}^{dump}\})$, we shall add the self-loop transitions labelled by events in $\Sigma_{c,a} \cap (\Sigma_{uo} \cup \Sigma_{s,a})$ since they can be enabled due to the actuator attack and are unobservable to the supervisor. At Step 5, all the other transitions, labelled by events in $(\Sigma - \Sigma_{s,A}) \cup \Gamma$, defined in $OCNS$ are kept. At Step 6 and Step 7, we shall explicitly encode the covertness-breaking situations: at any state $q \in Q_{ns}^{rea} \times (Q_o \cup \{q_{oc}^{dump}\})$, any event in Σ_o , which should not have been observed in the absence of attack, denoted by $\neg \xi_{ocns}(q, \sigma)!$, would lead to a transition labelled as $\sigma \in \Sigma_o - \Sigma_{s,a}$ or $\sigma^\# \in \Sigma_{s,a}^\#$ to the state q_{oc}^{brk} , meaning that the existence of the sensor-actuator attacker is exposed.

Based on the model of $OCNS^A$, we know that $|Q_{ocns}^a| = |Q_{ns}| \times (2|Q_o| + 1) + 1 \leq 2|Q| \times |Q_{ce}| \times (2|Q_o| + 1) + 1$.

Example IV.2 We shall continue with the water tank example. Based on **Step 2.1** - **Step 2.3**, the observation automaton M_o and the synthesized supremal safe command-nondeterministic supervisor NS shown in Fig. 9 and Fig. 14, respectively, we can obtain OC , $OCNS$ and $OCNS^A$, which are illustrated in Fig. 15, Fig. 19 and Fig. 20, respectively. To help readers understand the construction procedure, we also present the detailed explanations about how to construct these models step-by-step as well as the meaning of each model.

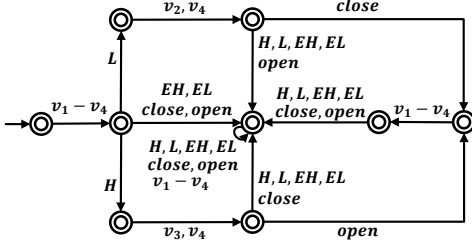

Fig. 15: The constructed OC

Based on **Step 2.1**, we shall explain how to construct OC (Fig. 16. (iii)) from M_o (Fig. 16. (i)).

1. We need to generate the state set of OC based on step 1, since $Q_o = \{0, 1, 2, 3\}$, we have $Q_{oc} = Q_o \cup Q_o^{com} \cup \{q_{oc}^{dump}\} = \{0, 1, 2, 3, 0^{com}, 1^{com}, 2^{com}, 3^{com}, q_{oc}^{dump}\}$, which is illustrated in Fig. 16. (ii).
2. We need to construct the transitions based on step 3. For example, if $q^{com} = 1^{com}$, then we have $En_{M_o}(1) = \{close\} \subseteq v_2 \Rightarrow \xi_{oc}(1^{com}, v_2) = 1$ and $En_{M_o}(1) = \{close\} \subseteq v_4 \Rightarrow \xi_{oc}(1^{com}, v_4) = 1$, which are illustrated by the transitions labelled as v_2 and v_4 from state 1^{com} to state 1 in Fig. 16. (ii).
3. We need to construct the transitions based on step 4. For example, if $q = 1$, then we have $\xi_o(1, close) = 3 \Rightarrow \xi_{oc}(1, close) = (\xi_o(1, close))^{com} = 3^{com}$, which is illustrated by the transition labelled as $close$ from state 1 to state 3^{com} in Fig. 16. (iii).

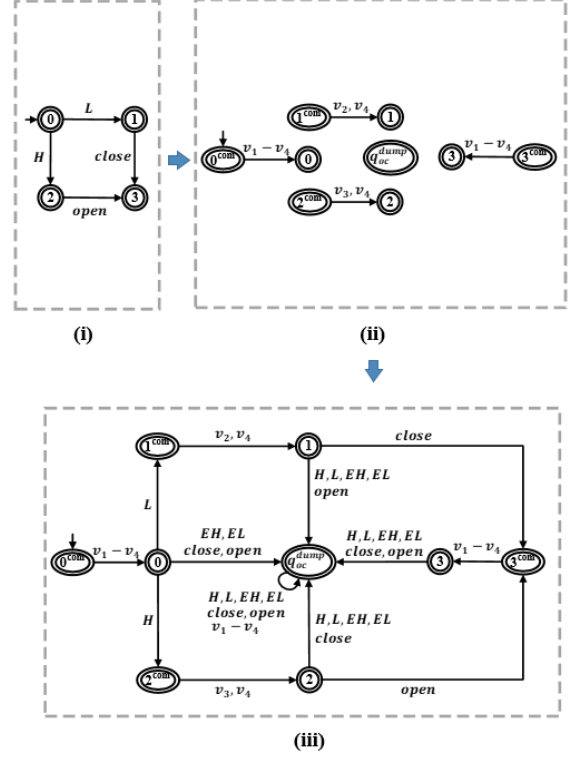

Fig. 16: The construction procedure of OC from M_o . (i) is M_o . (iii) is OC .

4. We need to construct the transitions based on step 5. For example, if $q = 1$, then we have $\neg \xi_o(1, H) \Rightarrow \xi_{oc}(1, H) = q_{oc}^{dump}$, which is illustrated by the transition labelled as H from state 1 to state q_{oc}^{dump} in Fig. 16. (iii).
5. Since there are no unobservable events in this example, the construction for step 6 is not needed.
6. Based on step 7, we need to add the self-loop transitions labelled as the events in $\Sigma \cup \Gamma = \{H, L, EH, EL, close, open, v_1, v_2, v_3, v_4\}$ at state q_{oc}^{dump} , which are illustrated in Fig. 16. (iii).

The meaning of OC is: OC encodes all the bipartite supervisors consistent with the collected observations M_o because the condition $En_{M_o}(q) \subseteq \gamma$ at step 3 would filter out those control commands that could not generate the obtained observations. OC could be interpreted in a similar way as NS , whose meaning is explained in the response to Comment 18. For example, at the initial state 0^{com} of OC , the bipartite supervisor that is consistent with observations could issue any control command in v_1, v_2, v_3 and v_4 because v_1, v_2, v_3 and v_4 could generate the observations H and L at the initial state 0 of M_o , after which OC would transit to state 0. Then, if the observation H is received, OC would transit to state 2^{com} , at which the bipartite supervisor that is consistent with observations could issue v_3 or v_4 because only v_3 and v_4 could generate the observation $open$ at state 2 of M_o . Similarly, the transition labelled as L at state 0 of OC and the transition labelled v_2 and v_4 at state 1^{com} of OC could be interpreted in this way. At state 0 of OC , the events in $\Sigma \cup \Gamma$ are not collected at state 0 of the model M_o , and the transitions

labelled as those events would lead to state q_{oc}^{dump} because it is still possible that they could happen although they are not collected in M_o due to the finite observations. In addition, after the occurrence of these uncollected observations, since they are not collected in M_o , implying that we are not sure what event could happen later following those uncollected observations, any event in $\Sigma \cup \Gamma$ is defined at state q_{oc}^{dump} such that any bipartite supervisor that is consistent with the observations O is embedded in OC .

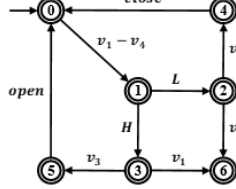

Fig. 17: The computed NS

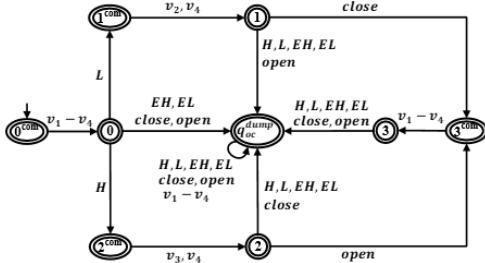

Fig. 18: The constructed OC

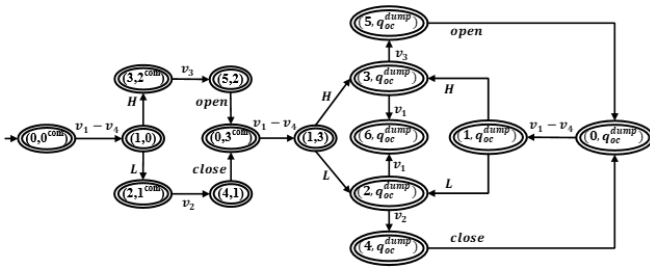

Fig. 19: The constructed $OCNS$

For the water tank example, based on NS and OC shown in Fig. 17 and Fig. 18, respectively, the constructed $OCNS$ is illustrated in Fig. 19. Based on the construction of $OCNS$, we know that it embeds any safe command non-deterministic supervisor that is consistent with the observations O . Thus, it can be interpreted in a similar way as NS and OC . For example, at the initial state $(0, 0^{com})$, it could issue any control command in v_1, v_2, v_3 and v_4 as these control commands can ensure the safety of the plant and the generation of the collected observations H and L at the initial state of M_o . After the command sending, $OCNS$ would transit to state $(1, 0)$, at which it may observe H or L , denoted by the transition labelled as H and L at state $(1, 0)$. If it receives the observation H and transits to state $(3, 2^{com})$, then it could issue the control

command v_3 as v_3 can ensure the safety of the plant and the generation of the collected observations $open$ at state 2 of M_o ; otherwise, i.e., if it receives the observation L and transits to state $(2, 1^{com})$, then it could issue the control command v_2 as v_2 can ensure the safety of the plant and the generation of the collected observations $close$ at state 1 of M_o .

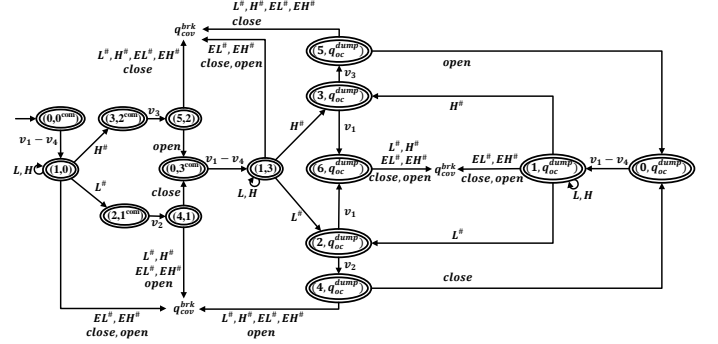

Fig. 20: The constructed $OCNS^A$

Based on **Step 2.3**, we shall explain how to construct $OCNS^A$ (Fig. 20).

1. Based on step 1, we shall add a new state q_{cov}^{brk} to explicitly denote that the supervisor has detected the existence of attack and the covertness of attackers has been broken.
2. We need to construct the transitions based on step 3. For example, if $q = (1, 0)$ and $q' = (3, 2^{com})$, then we have $\xi_{ocns}(q = (1, 0), H) = q' = (3, 2^{com}) \Rightarrow \xi_{ocns}^a(q = (1, 0), H\#) = q' = (3, 2^{com}) \wedge \xi_{ocns}^a(q = (1, 0), H) = (1, 0)$, which are illustrated by the transition labelled as $H\#$ from state $(1, 0)$ to state $(3, 2^{com})$ and the self-loop transition labelled as H at state $(1, 0)$ in Fig. 20.
3. We need to construct the transitions based on step 4. However, since $\Sigma_{c,a} \cap (\Sigma_{uo} \cup \Sigma_{s,a}) = \{close, open\} \cap (\emptyset \cup \{H, L, EH, EL\}) = \emptyset$, the construction for step 4 is not needed.
4. We need to construct the transitions based on step 5, that is, retain all the transitions of $OCNS$ labelled as events in $(\Sigma - \Sigma_{s,a}) \cup \Gamma$.
5. We need to construct the transitions based on step 6. For NS , its state set is divided into two sets, the set of reaction states Q_{ns}^{rea} and the set of control states Q_{ns}^{com} . For any state of Q_{ns}^{rea} , any event in Γ is not defined, thus, for NS shown in Fig. 17, we know its $Q_{ns}^{rea} = \{1, 4, 5, 6\}$. Then, based on step 6 and take $q = (1, 0)$ as an instance, we have $q = (1, 0) \in Q_{ns}^{rea} \times (Q_o \cup \{q_{oc}^{dump}\}) \wedge \neg \xi_{ocns}(q = (1, 0), close)! \Rightarrow \xi_{ocns}^a(q = (1, 0), close) = q_{cov}^{brk}$, which is illustrated by the transition labelled as $close$ from state $(1, 0)$ to state q_{cov}^{brk} in Fig. 20. Similarly, the transition labelled as $open$ at state $(1, 0)$ would also lead a transition to state q_{cov}^{brk} in Fig. 20.
6. We need to construct the transitions based on step 7. For example, if $q = (1, 0)$, then we have $q = (1, 0) \in Q_{ns}^{rea} \times (Q_o \cup \{q_{oc}^{dump}\}) \wedge \neg \xi_{ocns}(q = (1, 0), EH)! \Rightarrow \xi_{ocns}^a(q = (1, 0), EH\#) = q_{cov}^{brk}$, which is illustrated by the transition labelled as $EH\#$ from state $(1, 0)$ to state q_{cov}^{brk} in Fig. 20.

20. Similarly, the transition labelled as $EL^\#$ at state $(1, 0)$ would also result in a transition to state q_{cov}^{brk} in Fig. 20.

The meaning of $OCNS^A$ is: $OCNS^A$ embeds any safe command non-deterministic supervisor that is consistent with observations O , where the effects of sensor-actuator attacks, e.g., event relabelling for $\Sigma_{s,a}$, and the covertness-breaking situations of attackers are also encoded. For example, at the initial state $(0, 0^{com})$ of $OCNS^A$ in Fig. 20, it could issue any control command in v_1, v_2, v_3 and v_4 as these control commands can ensure the safety of the plant and the generation of the collected observations H and L at the initial state of M_o . After the command sending, it would transit to state $(1, 0)$, at which the event H or L could be executed at the plant. However, due the existence of the sensor attack, we have that events in $\Sigma_{s,a}$ are executed by the plant, while events in $\Sigma_{s,a}^\#$ are those attacked copies sent by the sensor attacker and received by the supervisor. Thus, the execution of H or L at the plant would lead to a self-loop transition at state $(1, 0)$ as they are unobservable to the supervisor, and only the transition labelled as $H^\#$ or $L^\#$ would lead to a state change, denoted by the transition labelled as $H^\#$ ($L^\#$, respectively) from state $(1, 0)$ to state $(3, 2^{com})$ (state $(2, 1^{com})$, respectively). In addition, in this work, we assume that the supervisor is embedded with a monitor to detect the existence of attacks, and once the information inconsistency happens, it could assert there exists an attack and halt the system execution. Thus, at state $(1, 0)$, i.e., the supervisor just issues the initial control command, it knows¹² that only $H^\#$ or $L^\#$ could be observed, and once any other event in $\{EL^\#, EH^\#, close, open\}$ is observed, it could assert that an attack happens, denoted by the transition labelled as events in $\{EL^\#, EH^\#, close, open\}$ from state $(1, 0)$ to state q_{cov}^{brk} , i.e., the covertness of attackers has been broken.

Theorem IV.1: Given a set of observations O , for any safe supervisor S that is consistent with O , i.e., $O \subseteq P_o(L(G||CE||BT(S)))$, it holds that $L(BT(S)^A) \subseteq L(OCNS^A)$.

Proof: See Appendix A. ■

Corollary IV.1: For any safe supervisor S consistent with O , if $s \in L(BT(S)^A)$, it holds that $\xi_{bs,a}(q_{bs,a}^{init}, s) = q^{detect} \Leftrightarrow \xi_{ocns}^{a}(q_{ocns}^{init,a}, s) = q_{cov}^{brk}$.

Proof: This follows from the analysis given in the proof of *Theorem IV.1*. ■

Step 3: Construction of $\overline{S^{\downarrow,A}}$

Next, as stated in the main idea of Section IV-A, we shall construct $\overline{S^{\downarrow,A}}$ [26], a complete automaton whose marked behavior models the least permissive supervisor (that is consistent with O) under attack. The step-by-step construction procedure is given as follows, including **Step 3.1** - **Step 3.3**.

Step 3.1: Construction of S^\downarrow

Based on the model $M_o = (Q_o, \Sigma_o, \xi_o, q_o^{init})$ that captures the observations O , we shall construct the least permissive

supervisor S^\downarrow [26] which is consistent with O . Let

$$S^\downarrow = (Q_s^\downarrow, \Sigma_s^\downarrow, \xi_s^\downarrow, q_s^{init,\downarrow})$$

1. $Q_s^\downarrow = Q_o$
2. $\Sigma_s^\downarrow = \Sigma$
3. $(\forall q, q' \in Q_o)(\forall \sigma \in \Sigma_o) \xi_o(q, \sigma) = q' \Rightarrow \xi_s^\downarrow(q, \sigma) = q'$. (transitions retaining)
4. $(\forall q \in Q_o)(\forall \sigma \in \Sigma_{uc} \cap \Sigma_{uo} = \Sigma_{uo}) \xi_s^\downarrow(q, \sigma) = q$. (controllability and observability requirement)
5. $(\forall q \in Q_o)(\forall \sigma \in \Sigma_{uc} \cap \Sigma_o) \neg \xi_o(q, \sigma)! \Rightarrow \xi_s^\downarrow(q, \sigma) = q_o^{dl}$. (controllability requirement)
6. $q_s^{init,\downarrow} = q_o^{init}$

At Step 3, we shall retain all the transitions originally defined in M_o . Then, at any state $q \in Q_o$, Step 4 and Step 5 would complete the undefined transitions labelled by events in Σ_{uc} to satisfy the controllability, where the unobservable parts would lead to self-loops at Step 4 to satisfy the observability, and the observable parts would transit to the deadlocked state q_o^{dl} at Step 5.

Theorem IV.2: Given a set of observations O , S^\downarrow is the least permissive supervisor among all the supervisors that are consistent with O .

Proof: See Appendix B. ■

Step 3.2: Construction of $S^{\downarrow,A}$

Based on S^\downarrow , we shall construct $S^{\downarrow,A}$, whose behavior encodes the least permissive supervisor (consistent with O) under the effects of the sensor-actuator attack. The following procedure is similar to the procedure of $BT(S)^A$ given in **Step 2** of Section III-D.

$$S^{\downarrow,A} = (Q_s^{\downarrow,a}, \Sigma_s^{\downarrow,a}, \xi_s^{\downarrow,a}, q_s^{init,\downarrow,a})$$

1. $Q_s^{\downarrow,a} = Q_s^\downarrow \cup \{q^{risk}\}$
2. $\Sigma_s^{\downarrow,a} = \Sigma \cup \Sigma_{s,a}^\#$
3. $(\forall q, q' \in Q_s^{\downarrow,a})(\forall \sigma \in \Sigma_{s,a}) \xi_s^\downarrow(q, \sigma) = q' \Rightarrow \xi_s^{\downarrow,a}(q, \sigma^\#) = q' \wedge \xi_s^{\downarrow,a}(q, \sigma) = q$.
4. $(\forall q \in Q_s^{\downarrow,a})(\forall \sigma \in \Sigma_{c,a} \cap (\Sigma_{uo} \cup \Sigma_{s,a})) \neg \xi_s^\downarrow(q, \sigma)! \Rightarrow \xi_s^{\downarrow,a}(q, \sigma) = q$.
5. $(\forall q, q' \in Q_s^{\downarrow,a})(\forall \sigma \in \Sigma - \Sigma_{s,a}) \xi_s^\downarrow(q, \sigma) = q' \Rightarrow \xi_s^{\downarrow,a}(q, \sigma) = q'$.
6. $(\forall q \in Q_s^{\downarrow,a})(\forall \sigma \in \Sigma_o - \Sigma_{s,a}) \neg \xi_s^\downarrow(q, \sigma)! \Rightarrow \xi_s^{\downarrow,a}(q, \sigma) = q^{risk}$.
7. $(\forall q \in Q_s^{\downarrow,a})(\forall \sigma \in \Sigma_{s,a}) \neg \xi_s^\downarrow(q, \sigma)! \Rightarrow \xi_s^{\downarrow,a}(q, \sigma^\#) = q^{risk}$.
8. $q_s^{init,\downarrow,a} = q_s^{init,\downarrow}$

The construction of $S^{\downarrow,A}$ is similar to that of $BT(S)^A$ in **Step 2** of Section III-D, where q^{risk} in $S^{\downarrow,A}$ serves as the same role as q^{detect} in $BT(S)^A$.

Step 3.3: Construction of $\overline{S^{\downarrow,A}}$

Based on $S^{\downarrow,A}$, we shall construct $\overline{S^{\downarrow,A}}$ by performing the completion to make $\overline{S^{\downarrow,A}}$ become a complete automaton, where now only the marked behavior encodes the least permissive supervisor (consistent with O) under attack. Intuitively speaking, as long as the attacker makes use of the marked behavior of $\overline{S^{\downarrow,A}}$ to implement attacks, it can ensure

¹² $OCNS^A$ is derived from the synchronous product of NS and OC , where NS already encodes the information that should be observed under the absence of attack, i.e., the monitoring mechanism is implicitly encoded in NS .

damage-infliction against any (unknown) safe supervisor that is consistent with the observations.

$$\overline{S^{\downarrow,A}} = (\overline{Q_s^{\downarrow,a}}, \overline{\Sigma_s^{\downarrow,a}}, \overline{\xi_s^{\downarrow,a}}, \overline{q_s^{init,\downarrow,a}}, \overline{Q_s^{\downarrow,a}})$$

1. $\overline{Q_s^{\downarrow,a}} = Q_s^{\downarrow,a} \cup \{q^{dump}\}$
2. $\overline{\Sigma_s^{\downarrow,a}} = \Sigma \cup \Sigma_{s,a}^{\#}$
3. $(\forall q, q' \in \overline{Q_s^{\downarrow,a}})(\forall \sigma \in \Sigma \cup \Sigma_{s,a}^{\#}) \xi_s^{\downarrow,a}(q, \sigma) = q' \Rightarrow \overline{\xi_s^{\downarrow,a}}(q, \sigma) = q'$. (transitions retaining)
4. $(\forall q \in \overline{Q_s^{\downarrow,a}})(\forall \sigma \in \Sigma \cup \Sigma_{s,a}^{\#}) \neg \xi_s^{\downarrow,a}(q, \sigma)! \Rightarrow \overline{\xi_s^{\downarrow,a}}(q, \sigma) = q^{dump}$. (transitions completion)
5. $(\forall \sigma \in \Sigma \cup \Sigma_{s,a}^{\#}) \xi_s^{\downarrow,a}(q^{dump}, \sigma) = q^{dump}$. (transitions completion)
6. $\overline{q_s^{init,\downarrow,a}} = q_s^{init,\downarrow,a}$
7. $\overline{Q_s^{\downarrow,m}} = Q_s^{\downarrow,a}$

Based on the model of $\overline{S^{\downarrow,A}}$, we know that $|\overline{Q_s^{\downarrow,a}}| = |Q_o| + 2$.

Example IV.3 We shall continue with the water tank example. Based on **Step 3.1** - **Step 3.3** and the observation automaton M_o shown in Fig. 9, we generate S^{\downarrow} , $S^{\downarrow,A}$ and $\overline{S^{\downarrow,A}}$, which are illustrated in Fig. 21, Fig. 23 and Fig. 25, respectively. To help readers understand the construction procedure, we also present the detailed explanations about how to construct these models step-by-step as well as the meaning of each model.

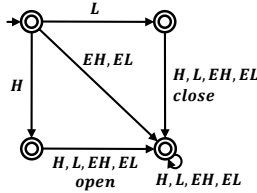

Fig. 21: The constructed S^{\downarrow}

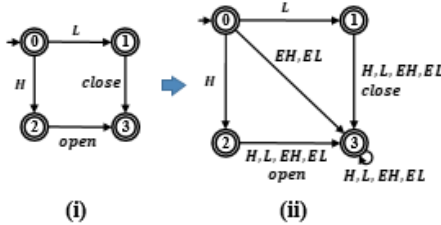

Fig. 22: The construction procedure of S^{\downarrow} from M_o . (i) is M_o . (ii) is S^{\downarrow} .

Based on **Step 3.1**, we shall explain how to construct S^{\downarrow} .

1. Based on step 1, the state set of S^{\downarrow} is the same as that of M_o , that is, $Q_s^{\downarrow} = Q_o = \{0, 1, 2, 3\}$.
2. We need to construct the transitions based on step 3, that is, retain all the transitions defined in M_o , which are illustrated in Fig. 22.
3. We need to construct the transitions based on step 4. Since all the events in this water tank example are observable, the construction for step 4 is not needed.

4. We need to construct the transitions based on step 5. For example, if $q = 0$, then we have $\neg \xi_o(q = 0, EH)! \Rightarrow \xi_s^{\downarrow}(q = 0, EH) = q_o^{dl} = 3$ and $\neg \xi_o(q = 0, EL)! \Rightarrow \xi_s^{\downarrow}(q = 0, EL) = q_o^{dl} = 3$, which are illustrated by the transitions labelled as EH and EL from state 0 to state 3 in Fig. 22.

The meaning of S^{\downarrow} : S^{\downarrow} encodes the least permissive supervisor that is consistent with observations O , which has been proved in Theorem IV.2 of the manuscript. We shall take the initial state of S^{\downarrow} as an instance to explain its meaning. At the initial state 0 in Fig. 22. (ii), H and L are defined because they are collected in the observations, implying that the supervisor must enable H and L at the initial state to ensure that S^{\downarrow} is consistent with the observations. In addition, to satisfy the controllability, i.e., any uncontrollable event should always be enabled by the supervisor, two more transitions labelled as EH and EL should also be added at the initial state 0 of S^{\downarrow} , leading to state 3.

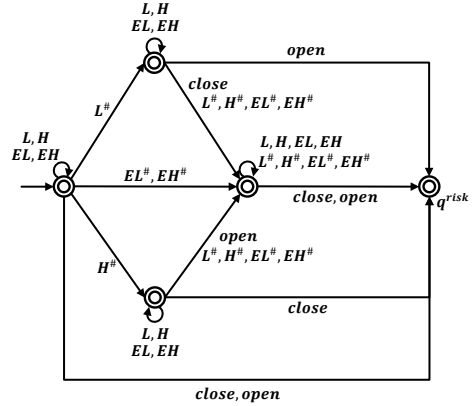

Fig. 23: The constructed $S^{\downarrow,A}$

Based on **Step 3.2** we shall explain how to construct $S^{\downarrow,A}$.

1. Based on step 1, a new state q^{risk} is added to the state set, thus, $Q_s^{\downarrow,a} = Q_s^{\downarrow} \cup \{q^{risk}\} = \{0, 1, 2, 3, q^{risk}\}$, illustrated in Fig. 24. (ii).
2. We need to construct the transitions based on step 3. For example, if $q = 0$ and $q' = 1$, then we have $\xi_s^{\downarrow}(q = 0, L) = q' = 1 \Rightarrow \xi_s^{\downarrow,a}(q = 0, L\#) = q' = 1 \wedge \xi_s^{\downarrow,a}(q = 0, L) = q = 0$, which is illustrated by the transition labelled as $L\#$ from state 0 to state 1 and the self-loop transition labelled as L at state 0 in Fig. 24. (ii). Similarly, we could construct the transitions labelled as $H\#$, $EL\#$ and $EH\#$ from state 0 to state 1 and the self-loop transitions labelled as H , EL and EH at state 0 in Fig. 24. (ii).
3. We need to construct the transitions based on step 4. However, since $\Sigma_{c,a} \cap (\Sigma_{uo} \cup \Sigma_{s,a}) = \{close, open\} \cap (\emptyset \cup \{H, L, EH, EL\}) = \emptyset$, the construction for step 4 is not needed.
4. We need to construct the transitions based on step 5. For example, if $q = 1$ and $q' = 3$, then we have $\xi_s^{\downarrow}(q = 1, close) = q' = 3 \Rightarrow \xi_s^{\downarrow,a}(q = 1, close) = q' = 3$, which is illustrated by the transition labelled as $close$ from state 1 to state 3 in Fig. 24. (iii). Similarly, we could construct the transitions labelled as $open$ from state 2 to state 3 in Fig. 24. (iii).

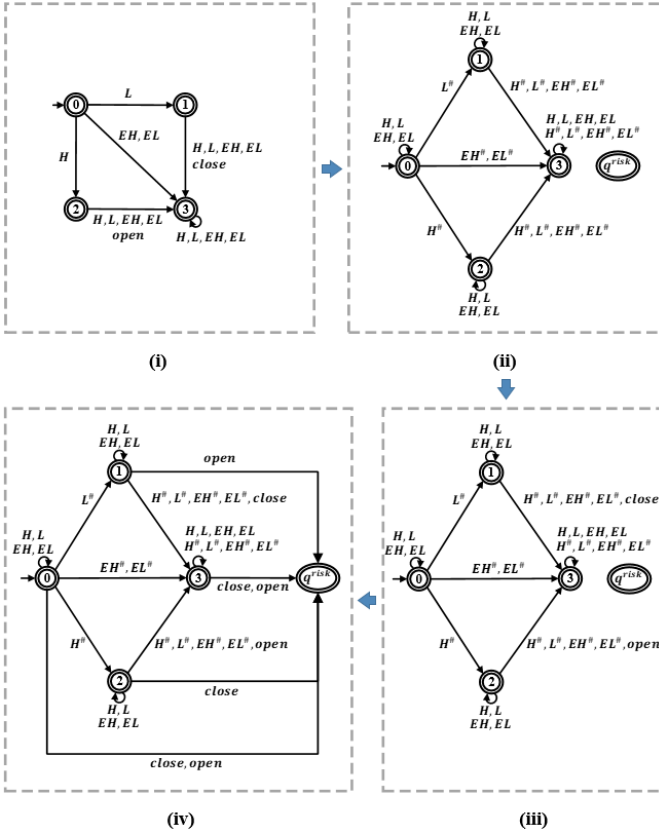

Fig. 24: The construction procedure of $S^{\downarrow, A}$ from S^{\downarrow} . (i) is S^{\downarrow} . (iv) is $S^{\downarrow, A}$.

- We need to construct the transitions based on step 6. For example, if $q = 1$, then we have $\neg \xi_s^{\downarrow}(q = 1, open) \Rightarrow \xi_s^{\downarrow, a}(q = 1, open) = q^{risk}$, which is illustrated by the transition labelled as *open* from state 1 to state q^{risk} in Fig. 24. (iv). Similarly, we could construct 1) the transitions labelled as *close* and *open* from state 0 to state q^{risk} , 2) the transition labelled as *close* from state 2 to state q^{risk} , and 3) the transitions labelled as *close* and *open* from state 3 to state q^{risk} in Fig. 24. (iv).
- We need to construct the transitions based on step 7. It can be checked that there are no new transitions satisfying the condition given at this step.

The meaning of $S^{\downarrow, A}$: $S^{\downarrow, A}$ represents the least permissive supervisor that is consistent with the collected observations, where the effects of sensor actuator attacks are encoded. For example, at the initial state 0 of $S^{\downarrow, A}$ in Fig. 24. (iv), H and L are enabled by the supervisor because they are collected in the observations, and EH and EL are also enabled by the supervisor because they are uncontrollable events, which should always be enabled. However, due to the existence of sensor attacks, events in $\Sigma_{s, a}$ are the ones executed in the plant and only the attacked copies in $\Sigma_{s, a}^{\#}$ are the events sent by the sensor attacker and could be observed by the supervisor. Thus, at the initial state 0 of $S^{\downarrow, A}$, the transitions labelled as events H, L, EH and EL are self-loops while the transitions labelled as $H^{\#}, L^{\#}, EH^{\#}$ and $EL^{\#}$ could enable $S^{\downarrow, A}$ to make a state transition, meaning that $H^{\#}, L^{\#}, EH^{\#}$ and $EL^{\#}$ are

observed by the supervisor. The transitions labelled as *close* and *open* from the initial state 0 to state q^{risk} mean that: Although *close* and *open* are not collected at the initial state of M_o due to the finite observations, it is still possible that they are enabled by some supervisor. However, taking using of such uncollected event enabling information by the attacker is risky as the attacker might not be covert against any supervisor that is consistent with the collected observations. Thus, the transitions labelled as *close* and *open* at state 0 would lead to state q^{risk} .

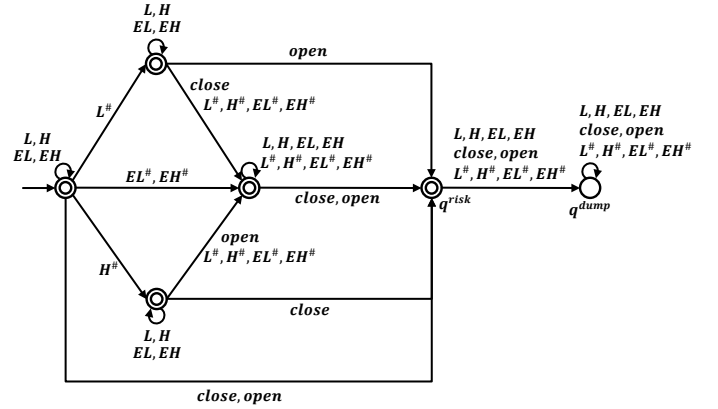

Fig. 25: The constructed $S^{\downarrow, A}$

Based on **Step 3.3**, we shall explain how to construct $S^{\downarrow, A}$.

- Based on step 1, a new state q^{dump} is added to the state set, thus, $Q_s^{\downarrow, a} = Q_s^{\downarrow, a} \cup \{q^{dump}\} = \{0, 1, 2, 3, q^{risk}, q^{dump}\}$, illustrated in Fig. 25.
- We need to construct the transitions based on step 3, that is, retain all the transitions defined in $S^{\downarrow, A}$, which are illustrated in Fig. 25.
- We need to construct the transitions based on step 4 and step 5, that is, for any state of $S^{\downarrow, A}$, we shall add the transitions, labelled as events in $\Sigma \cup \Sigma_{s, a}^{\#} = \{H, L, EH, EL, close, open, H^{\#}, L^{\#}, EH^{\#}, EL^{\#}\}$, that are not defined at that state to make $S^{\downarrow, A}$ become a complete automaton.

The meaning of $S^{\downarrow, A}$: $S^{\downarrow, A}$ can be interpreted in a similar way to $S^{\downarrow, A}$, and the only difference is that $S^{\downarrow, A}$ is a complete automaton while $S^{\downarrow, A}$ is not. Our motivation for constructing such a complete automaton, where only the marked behavior encodes the least permissive supervisor (consistent with O) under attack, is to provide convenience when we prove the decidability result in Theorem IV.5. Intuitively speaking, as long as the attacker makes use of the marked behavior of $S^{\downarrow, A}$ to implement attacks, it can ensure damage-infliction against any (unknown) safe supervisor that is consistent with the observations.

Step 4: Synthesis of the sensor-actuator attacker A

Now, we are ready to provide the procedure for the synthesis of the supremal covert damage-reachable sensor-actuator attacker against all the safe supervisors that are consistent with the observations, which is given as follows:

Procedure 2:

1. Compute $\mathcal{P} = G||CE^A||AC||OCNS^A||\overline{S^{\downarrow,A}} = (Q_{\mathcal{P}}, \Sigma_{\mathcal{P}}, \xi_{\mathcal{P}}, q_{\mathcal{P}}^{init}, Q_{\mathcal{P},m})$.
2. Generate $\mathcal{P}_r = (Q_{\mathcal{P}_r}, \Sigma_{\mathcal{P}_r}, \xi_{\mathcal{P}_r}, q_{\mathcal{P}_r}^{init}, Q_{\mathcal{P}_r,m})$.
 - $Q_{\mathcal{P}_r} = Q_{\mathcal{P}} - Q_1$
 - $Q_1 = \{(q, q_{ce,a}, q_{ac}, q_{ocns}^a, \overline{q_s^{\downarrow,a}}) \in Q_{\mathcal{P}} \mid q \notin Q_d \wedge q_{ocns}^a = q_{cov}^{brk}\}$
 - $\Sigma_{\mathcal{P}_r} = \Sigma_{\mathcal{P}}$
 - $(\forall q, q' \in Q_{\mathcal{P}_r})(\forall \sigma \in \Sigma_{\mathcal{P}_r}) \xi_{\mathcal{P}}(q, \sigma) = q' \Leftrightarrow \xi_{\mathcal{P}_r}(q, \sigma) = q'$
 - $q_{\mathcal{P}_r}^{init} = q_{\mathcal{P}}^{init}$
 - $Q_{\mathcal{P}_r,m} = Q_{\mathcal{P},m} - Q_1$
3. Synthesize the supremal supervisor $\mathcal{A} = (Q_a, \Sigma_a, \xi_a, q_a^{init}, Q_{a,m})$ over the attacker's control constraint \mathcal{C}_{ac} by treating \mathcal{P} as the plant and \mathcal{P}_r as the requirement such that $\mathcal{P}||\mathcal{A}$ is marker-reachable and safe w.r.t. \mathcal{P}_r .

We shall briefly explain **Procedure 2**. At Step 1, we generate a new plant $\mathcal{P} = G||CE^A||AC||OCNS^A||\overline{S^{\downarrow,A}}$. At Step 2, we generate the requirement \mathcal{P}_r from \mathcal{P} by removing those states where the covertness is broken, denoted by $q \notin Q_d \wedge q_{ocns}^a = q_{cov}^{brk}$. Then we synthesize the supremal sensor-actuator attacker at Step 3. Intuitively speaking, 1) since $OCNS^A$ have encoded all the safe bipartite supervisors that are consistent with the observations O , removing those covertness-breaking states in the requirement \mathcal{P}_r can enforce the covertness against any unknown safe supervisor that is consistent with O , and 2) since the marked behavior of $\overline{S^{\downarrow,A}}$ encodes the least permissive supervisor under attack, ensuring the marker-reachability for $\mathcal{P}||\mathcal{A}$ can enforce that the attacker can always cause damage-infliction against any (unknown) safe supervisor that is consistent with O .

Next, we shall formally prove the correctness of the proposed solution methodology.

Theorem IV.3: Given a set of observations O , the sensor-actuator attacker \mathcal{A} generated in **Procedure 2**, if non-empty, is covert for any safe supervisor that is consistent with O .

Proof: See Appendix C. ■

Theorem IV.4: Given a set of observations O , the sensor-actuator attacker \mathcal{A} generated in **Procedure 2**, if non-empty, is damage-reachable for any safe supervisor that is consistent with O .

Proof: See Appendix D. ■

Now, we are ready to show that **Problem 1**, the main problem to be solved in this work, can be reduced to a Ramadge-Wonham supervisory control problem.

Theorem IV.5: Given the plant G and a set of observations O , there exists a covert damage-reachable sensor-actuator attacker $\mathcal{A} = (Q_a, \Sigma_a, \xi_a, q_a^{init})$ w.r.t. the attack constraint $(\Sigma_o, \Sigma_{s,a}, \Sigma_{c,a})$ against any safe supervisor that is consistent with O if and only if there exists a supervisor S' over the attacker's control constraint \mathcal{C}_{ac} for the plant $\mathcal{P} = G||CE^A||AC||OCNS^A||\overline{S^{\downarrow,A}}$ such that

- a) Any state in $\{(q, q_{ce,a}, q_{ac}, q_{ocns}^a, \overline{q_s^{\downarrow,a}}, q'_s) \in Q \times Q_{ce,a} \times Q_{ac} \times Q_{ocns}^a \times \overline{Q_s^{\downarrow,a}} \times Q'_s \mid q \notin Q_d \wedge q_{ocns}^a = q_{cov}^{brk}\}$ is not reachable in $\mathcal{P}||S'$, where Q'_s is the state set of S' .

- b) $\mathcal{P}||S'$ is marker-reachable.

Proof: See Appendix E. ■

Theorem IV.6: The sensor-actuator attacker \mathcal{A} generated in **Procedure 2**, if non-empty, is a solution for **Problem 1**.

Proof: Based on *Theorem IV.5*, the problem of synthesizing a covert damage-reachable sensor-actuator attacker \mathcal{A} w.r.t. the attack constraint $(\Sigma_o, \Sigma_{s,a}, \Sigma_{c,a})$ against any safe supervisor that is consistent with the observations O has been reduced to a Ramadge-Wonham supervisory control problem formulated at Step 3 of **Procedure 2**. Thus, **Procedure 2** can synthesize the supremal covert damage-reachable sensor-actuator attacker against any (unknown) safe supervisor that is consistent with the observations O for **Problem 1**. ■

Theorem IV.7: The supremal covert damage-reachable sensor-actuator attacker against any safe supervisor that is consistent with O exists.

Proof: This is straightforward based on the attacker's control constraint $\mathcal{C}_{ac} = (\Sigma_{c,a} \cup \Sigma_{s,a}^{\#} \cup \{stop\}, \Sigma_o \cup \Sigma_{s,a}^{\#} \cup \{stop\})$ and the fact that $\Sigma_{c,a} \subseteq \Sigma_c \subseteq \Sigma_o$. ■

Theorem IV.8: **Problem 1** is decidable.

Proof: Based on *Theorem IV.5* and *Theorem IV.6*, and the fact that **Procedure 2** terminates within finite steps, we immediately have this result. ■

Next, we shall analyze the computational complexity of the proposed algorithm to synthesize a covert damage-reachable sensor-actuator attacker, which depends on the complexity of two synthesis steps: **Procedure 1** and **Procedure 2**. By using the normality based synthesis approach [1], [34], the complexity of **Procedure 1** and **Procedure 2** are $O((|\Sigma| + |\Gamma|)2^{|\mathcal{Q}| \times |Q_{ce}|})$ and $O((|\Sigma| + |\Gamma|)2^{|\mathcal{Q}_{\mathcal{P}}|})$, respectively, where

- $|Q_{\mathcal{P}}| = |Q| \times |Q_{ce,a}| \times |Q_{ac}| \times |Q_{ocns}^a| \times |\overline{Q_s^{\downarrow,a}}|$
- $|Q_{ce}| = |Q_{ce,a}| = |\Gamma| + 1$
- $|Q_{ac}| = 3$
- $|Q_{ocns}^a| \leq 2^{|\mathcal{Q}| \times |Q_{ce}|} \times (2|Q_o| + 1) + 1$
- $|\overline{Q_s^{\downarrow,a}}| = |Q_o| + 2$

Thus, the computational complexity of the proposed algorithm is $O((|\Sigma| + |\Gamma|)2^{|\mathcal{Q}| \times |Q_{ce}|} + (|\Sigma| + |\Gamma|)2^{|\mathcal{Q}_{\mathcal{P}}|}) = O((|\Sigma| + |\Gamma|)2^{|\mathcal{Q}_{\mathcal{P}}|})$, which is doubly exponential due to the partial observation supervisor synthesis algorithm in **Procedure 2** and the exponential blowup in the state size of $OCNS^A$. However, we are not sure if the above analysis of the doubly exponential complexity upper bound is tight. This is left as a future work.

Remark IV.1: If we remove the assumption that $\Sigma_c \subseteq \Sigma_o$, then **Procedure 2** is still a sound procedure for **Problem 1** but it is in general not complete, as now S^{\downarrow} is only an under-approximation of any supervisor that is consistent with O [26].

Example IV.4 We shall continue with the water tank example. Based on **Procedure 2**, we can use **SuSyNA** [35] to synthesize the supremal covert damage-reachable sensor-actuator attacker \mathcal{A} , which is illustrated in Fig. 26.

Intuitively, the attack strategy of the synthesized sensor-actuator attacker \mathcal{A} is explained as follows. Upon the observation of H (L , respectively), it would immediately replace it with the fake sensing information $L^{\#}$ ($H^{\#}$, respectively). Once the supervisor receives the fake information, it will issue the inappropriate control command v_2 (v_3 , respectively). When

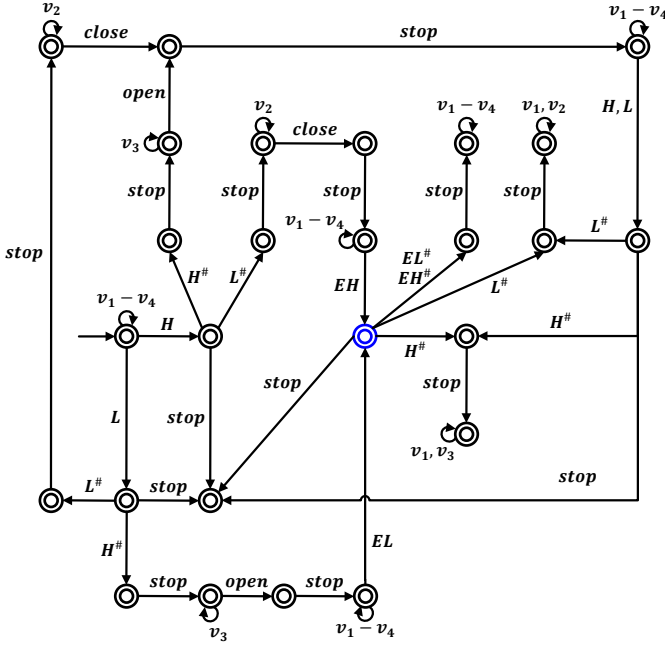

Fig. 26: The synthesized supremal covert damage-reachable sensor-actuator attacker \mathcal{A} . The state marked blue is a state denoting that the damage infliction has been caused to G .

the water tank system receives such a control command, it will execute the event *close* (*open*, respectively), resulting in that the water level becomes EH (EL , respectively), that is, the damage-infliction goal is achieved. In addition, such an attack strategy would always allow the attacker to remain covert against any safe supervisor that is consistent with the observations O shown in Fig. 9.

V. CONCLUSIONS

This work investigates the problem of synthesizing the supremal covert sensor-actuator attacker to ensure damage reachability against unknown supervisors, where only a finite set of collected observations instead of the supervisor model is needed. We have shown the decidability of the observation-assisted covert damage-reachable attacker synthesis problem. Our solution methodology is to reduce the original problem into the Ramadge-Wonham supervisory control problem, which allows several existing synthesis tools [35]-[37] to be used for the synthesis of covert damage-reachable attackers against unknown supervisors. In the future works, we shall relax the assumption $\Sigma_c \subseteq \Sigma_o$ and study the decidability problem, and explore more powerful synthesis approaches to achieve the damage-nonblocking goal against unknown supervisors. Another interesting topic is to find the minimal supervisor information needed to synthesize an attacker, which is naturally related to an optimization problem, and one possible way is to introduce cost function w.r.t. the supervisor information, similar to [39].

APPENDIX A PROOF OF THEOREM IV.1

Firstly, we prove $L(BT(S)^M) \subseteq L(OCNS) = L(NS||OC)$. To prove this result, we only need to show $L(BT(S)) \subseteq L(OCNS) = L(NS||OC)$ as $L(BT(S)^M) \subseteq L(BT(S))$. It is straightforward that $L(BT(S)) \subseteq L(NS)$ as $BT(S)$ is safe and NS is the supremal safe command-nondeterministic supervisor. It is also clear that $L(BT(S)) \subseteq L(OC)$, as $BT(S)$ is consistent with observation O and OC embeds any supervisor that is consistent with O . Thus, $L(BT(S)^M) \subseteq L(BT(S)) \subseteq L(NS) \cap L(OC) = L(OCNS)$.

For any string $s \in L(BT(S)^M)$ of the form $s_1\gamma$, where $\gamma \in \Gamma$, based on the above analysis, we have $s \in L(OCNS) = L(OC) \cap L(NS)$. Thus, we have $En_{OCNS}(\xi_{ocns}(q_{ocns}^{init}, s)) = En_{OC}(\xi_{oc}(q_{oc}^{init}, s)) \cap En_{NS}(\xi_{ns}(q_{ns}^{init}, s)) = En_{NS}(\xi_{ns}(q_{ns}^{init}, s))$ as any event in Σ is defined at the state $\xi_{oc}(q_{oc}^{init}, s)$ of OC by construction. Since $NS||P_{\Sigma_o \cup \Gamma}(G||CE) = NS$ and $BT(S)^M = BT(S)||P_{\Sigma_o \cup \Gamma}(G||CE)$, we have $En_{OCNS}(\xi_{ocns}(q_{ocns}, s)) = En_{NS}(\xi_{ns}(q_{ns}^{init}, s)) = En_{BT(S)^M}(\xi_{bs,1}(q_{bs,1}^{init}, s))$. Since **Step 2** of constructing $BT(S)^A$ based on $BT(S)^M$ in Section III-D and **Step 2.3** of constructing $OCNS^A$ based on $OCNS$ follow the same procedures, we conclude that $L(BT(S)^A) \subseteq L(OCNS^A)$. This completes the proof. \blacksquare

APPENDIX B PROOF OF THEOREM IV.2

Firstly, we prove S^\downarrow is consistent with O . Since O is a finite set of observations of the executions of $G||S$, we have $O \subseteq P_o(L(G||S))$. Thus, $O \subseteq P_o(L(G))$. Since $L(S^\downarrow) = P_o^{-1}(O(\Sigma_{uc} \cap \Sigma_o)^*)$, we have $P_o(L(G||S^\downarrow)) = P_o(L(G) \cap P_o^{-1}(O(\Sigma_{uc} \cap \Sigma_o)^*)) = P_o(L(G)) \cap O(\Sigma_{uc} \cap \Sigma_o)^* \supseteq O$. Secondly, we prove S^\downarrow is the least permissive supervisor that is consistent with O . We use the fact that every supervisor S over the control constraint (Σ_c, Σ_o) , where $\Sigma_c \subseteq \Sigma_o$, satisfies $L(S) = P_o^{-1}(P_o(L(S))(\Sigma_{uc} \cap \Sigma_o)^*)$ [38]. Thus, for any supervisor S consistent with O , since $O \subseteq P_o(L(G||S)) = P_o(L(G) \cap P_o^{-1}(P_o(L(S))(\Sigma_{uc} \cap \Sigma_o)^*)) = P_o(L(G)) \cap P_o(L(S))(\Sigma_{uc} \cap \Sigma_o)^*$, we have $O \subseteq P_o(L(S))(\Sigma_{uc} \cap \Sigma_o)^*$. Thus, $L(S^\downarrow) = P_o^{-1}(O(\Sigma_{uc} \cap \Sigma_o)^*) \subseteq P_o^{-1}(P_o(L(S))(\Sigma_{uc} \cap \Sigma_o)^*) = L(S)$. This completes the proof. \blacksquare

APPENDIX C PROOF OF THEOREM IV.3

We need to prove that, for any safe supervisor S , any state in $\{(q, q_{ce,a}, q_{ac}, q_{bs,a}, q_a) \in Q \times Q_{ce,a} \times Q_{ac} \times Q_{bs,a} \times Q_a \mid q \notin Q_d \wedge q_{bs,a} = q^{detect}\}$ is not reachable in $G||CE^A||AC||BT(S)^A||\mathcal{A}$. We adopt the contradiction. Suppose some above-mentioned state, where $q \in Q - Q_d$, $q_{bs,a} = q^{detect}$, can be reached in $G||CE^A||AC||BT(S)^A||\mathcal{A}$ via some string $s \in L(G||CE^A||AC||BT(S)^A||\mathcal{A})$. Then, s can be executed in G , CE^A , AC , $BT(S)^A$, and \mathcal{A} , after we lift their alphabets to $\Sigma \cup \Sigma_{s,a}^\# \cup \Gamma \cup \{stop\}$. Then, based on *Theorem IV.1* and the construction of $\overline{S^{\downarrow, \mathcal{A}}}$, which is a complete automaton, we know that s can be executed

in $OCNS^A$, and $\overline{S^{\downarrow,A}}$. Thus, s can also be executed in $G||CE^A||AC||OCNS^A||\overline{S^{\downarrow,A}}||\mathcal{A}$. Next, we shall check what state is reached in $G||CE^A||AC||OCNS^A||\overline{S^{\downarrow,A}}||\mathcal{A}$ via the string s . Clearly, state $q \in Q - Q_d$ is reached in G and state q_{cov}^{brk} is reached in $OCNS^A$ according to *Corollary IV.1*. Thus, the state $(q, q_{ce,a}, q_{ac}, q_{cov}^{brk}, q_s^{\downarrow,a}, q_a)$, where $q \in Q - Q_d$, is reached in $G||CE^A||AC||OCNS^A||\overline{S^{\downarrow,A}}||\mathcal{A}$ via the string s , which is a contradiction to the fact that \mathcal{A} is a safe supervisor for the plant $G||CE^A||AC||OCNS^A||\overline{S^{\downarrow,A}}$ based on Step 3 of **Procedure 2**. Then, the supposition does not hold and the proof is completed. ■

APPENDIX D PROOF OF THEOREM IV.4

Firstly, the sensor-actuator attacker \mathcal{A} generated in **Procedure 2**, if non-empty, must satisfy that $\mathcal{P}||\mathcal{A}$ is marker-reachable, i.e., some state $(q, q_{ce,a}, q_{ac}, q_{ocns}^a, q_s^{\downarrow,a}, q_a) \in Q_d \times Q_{ce,a} \times Q_{ac} \times Q_{ocns}^a \times Q_{s,m}^{\downarrow,a} \times Q_a$ can be reached in $G||CE^A||AC||OCNS^A||\overline{S^{\downarrow,A}}||\mathcal{A}$ via some string $s \in L(G||CE^A||AC||OCNS^A||\overline{S^{\downarrow,A}}||\mathcal{A})$ such that $P_{\Sigma \cup \Sigma_{s,a}^{\#}}(s) \in L_m(\overline{S^{\downarrow,A}})$, where $P_{\Sigma \cup \Sigma_{s,a}^{\#}} : (\Sigma \cup \Sigma_{s,a}^{\#} \cup \Gamma \cup \{stop\})^* \rightarrow (\Sigma \cup \Sigma_{s,a}^{\#})^*$. According to *Theorem IV.2* that S^{\downarrow} is the least permissive supervisor that is consistent with O , we know that for any other supervisor S that is consistent with O , there always exists a string $s' \in (\Sigma \cup \Sigma_{s,a}^{\#} \cup \Gamma \cup \{stop\})^*$ such that $P_{\Sigma \cup \Sigma_{s,a}^{\#}}(s') = P_{\Sigma \cup \Sigma_{s,a}^{\#}}(s)$ and s' can be executed in $G, CE^A, AC, BT(S)^A$, and \mathcal{A} after we lift their alphabets to $\Sigma \cup \Sigma_{s,a}^{\#} \cup \Gamma \cup \{stop\}$. Thus, s' can be executed in $G||CE^A||AC||BT(S)^A||\mathcal{A}$ and the state $q \in Q_d$ is reached in G via the string s' , i.e., some marker state is reachable in $G||CE^A||AC||BT(S)^A||\mathcal{A}$. This completes the proof. ■

APPENDIX E PROOF OF THEOREM IV.5

(If) Suppose there exists a supervisor S' over the attacker's control constraint \mathcal{C}_{ac} for the plant $\mathcal{P} = G||CE^A||AC||OCNS^A||\overline{S^{\downarrow,A}}$ such that the above Condition a) and Condition b) are satisfied. Then, based on *Theorem IV.3* and *Theorem IV.4*, we know that $\mathcal{A} = S'$ is a covert damage-reachable sensor-actuator attacker w.r.t. the attack constraint $(\Sigma_o, \Sigma_{s,a}, \Sigma_{c,a})$ against any safe supervisor that is consistent with O . This completes the proof of sufficiency.

(Only if) We need to prove that \mathcal{A} can satisfy the Condition a) and Condition b) w.r.t. the plant \mathcal{P} and thus we can choose $S' = \mathcal{A}$. Firstly, we shall show that any state in $\{(q, q_{ce,a}, q_{ac}, q_{ocns}^a, q_s^{\downarrow,a}, q_a) \in Q \times Q_{ce,a} \times Q_{ac} \times Q_{ocns}^a \times Q_{s,m}^{\downarrow,a} \times Q_a | q \notin Q_d \wedge q_{ocns}^a = q_{cov}^{brk}\}$ is not reachable in $\mathcal{P}||\mathcal{A} = G||CE^A||AC||OCNS^A||\overline{S^{\downarrow,A}}||\mathcal{A}$. We carry out the proof by contradiction and suppose that some state $(q, q_{ce,a}, q_{ac}, q_{ocns}^a, q_s^{\downarrow,a}, q_a) \in Q \times Q_{ce,a} \times Q_{ac} \times Q_{ocns}^a \times Q_{s,m}^{\downarrow,a} \times Q_a$, where $q \in Q - Q_d, q_{ocns}^a = q_{cov}^{brk}$ can be reached in $G||CE^A||AC||OCNS^A||\overline{S^{\downarrow,A}}||\mathcal{A}$ via a string s . Thus, s can be executed in $G, CE^A, AC, OCNS^A$, and \mathcal{A} after we lift their alphabets to $\Sigma \cup \Sigma_{s,a}^{\#} \cup \Gamma \cup \{stop\}$. Since $OCNS^A$ only embeds all the safe bipartite supervisors that are consistent

with O (under attack), we can always find a safe supervisor S that is consistent with O such that s can be executed in $BT(S)^A$ and the state q^{detect} is reached in $BT(S)^A$ via the string s . Thus, in $G||CE^A||AC||BT(S)^A||\mathcal{A}$, the state $(q, q_{ce,a}, q_{ac}, q_{bs,a}, q_a) \in Q \times Q_{ce,a} \times Q_{ac} \times Q_{bs,a} \times Q_a$, where $q \in Q - Q_d, q_{bs,a} = q^{detect}$, can be reached via the string s , and this causes the contradiction with the fact that \mathcal{A} is covert against against any safe supervisor that is consistent with O . Thus, the supposition does not hold.

Secondly, since \mathcal{A} is damage-reachable against any safe supervisor that is consistent with O , we know that \mathcal{A} is also damage-reachable against S^{\downarrow} , the least permissive supervisor that is consistent with O based on *Theorem IV.2*. Thus, $G||CE^A||AC||BT(S^{\downarrow})^A||\mathcal{A}$ is marker-reachable, i.e., some state $(q, q_{ce,a}, q_{ac}, q_{bs,a}, q_a) \in Q_d \times Q_{ce,a} \times Q_{ac} \times Q_{bs,a} \times Q_a$ can be reached in $G||CE^A||AC||BT(S^{\downarrow})^A||\mathcal{A}$ via some string $s \in L(G||CE^A||AC||BT(S^{\downarrow})^A||\mathcal{A})$. Then, s can be executed in $G, CE^A, AC, BT(S^{\downarrow})^A$, and \mathcal{A} , after we lift their alphabets to $\Sigma \cup \Sigma_{s,a}^{\#} \cup \Gamma \cup \{stop\}$. Based on *Theorem IV.1* and the construction of $\overline{S^{\downarrow,A}}$, which is a complete automaton, we know that s can be executed in $OCNS^A$ and $\overline{S^{\downarrow,A}}$, and $P_{\Sigma \cup \Sigma_{s,a}^{\#}}(s) \in L_m(\overline{S^{\downarrow,A}})$. Thus, some state $(q, q_{ce,a}, q_{ac}, q_{ocns}^a, q_s^{\downarrow,a}, q_a) \in Q_d \times Q_{ce,a} \times Q_{ac} \times Q_{ocns}^a \times Q_{s,m}^{\downarrow,a} \times Q_a$ is reached in $G||CE^A||AC||OCNS^A||\overline{S^{\downarrow,A}}||\mathcal{A}$ via the string s , i.e., $G||CE^A||AC||OCNS^A||\overline{S^{\downarrow,A}}||\mathcal{A}$ is marker-reachable. This completes the proof of necessity. ■

REFERENCES

- [1] W. M. Wonham and K. Cai, *Supervisory Control of Discrete-Event Systems*. Springer, 2018.
- [2] L. K. Carvalho, Y. C. Wu, R. Kwong, S. Lafortune, "Detection and prevention of actuator enablement attacks in supervisory control systems", *Proc. 13th Int. Workshop Discrete Event Syst.*, pp. 298-305, 2016.
- [3] L. K. Carvalho, Y.-C. Wu, R. Kwong and S. Lafortune, "Detection and mitigation of classes of attacks in supervisory control systems," *Automatica*, vol. 97, pp. 121-133, Nov. 2018.
- [4] P. M. Lima, M. V. S. Alves, L. K. Carvalho and M. V. Moreira, "Security against network attacks in supervisory control systems," *IFAC-PapersOnLine*, vol. 50, no. 1, pp. 12333-12338, Jul. 2017.
- [5] P. M. Lima, L. K. Carvalho and M. V. Moreira, "Detectable and undetectable network attack security of cyber-physical systems," *IFAC-PapersOnLine*, vol. 51, no. 7, pp. 179-185, 2018.
- [6] M. Wakaiki, P. Tabuada, J. P. Hespanha, "Supervisory control of discrete-event systems under attacks", *Dynamic Games and Applications*, vol. 9, no. 4, pp. 965-983, 2019.
- [7] Y. Wang, M. Pajic, "Supervisory control of discrete event systems in the presence of sensor and actuator attacks", *Proc. IEEE 58th Annu. Conf. Decis. Control (CDC)*, pp. 5350-5355, 2019.
- [8] R. Meira-Goes, E. Kang, R. Kwong, S. Lafortune, "Stealthy deception attacks for cyber-physical systems", *Proc. IEEE 56th Annu. Conf. Decis. Control (CDC)*, pp: 4224-4230, 2017.
- [9] R. Meira-Góes, E. Kang, R. Kwong, and S. Lafortune, "Synthesis of sensor deception attacks at the supervisory layer of cyber-physical systems," *Automatica*, vol. 121, Nov. 2020.
- [10] S. Mohajerani, R. Meira-Goes, S. Lafortune, "Efficient synthesis of sensor deception attacks using observation equivalence-based abstraction", *Proc. 15th Int. Workshop Discrete Event Syst.*, pp. 28-34, 2020.
- [11] L. Lin, S. Thuijsman, Y. Zhu, S. Ware, R. Su, M. Reniers, "Synthesis of successful actuator attackers on supervisors", *American Control Conference*, pp. 5614-5619, 2019.
- [12] L. Lin, Y. Zhu, R. Su, "Synthesis of covert actuator attackers for free", *Discrete Event Dynamic Systems: Theory and Applications*, vol. 30, pp. 561-577, 2020.
- [13] L. Lin and R. Su, "Synthesis of covert actuator and sensor attackers as supervisor synthesis," *Proc. 15th Int. Workshop Discrete Event Syst.*, pp. 1-6, 2020.

- [14] L. Lin, R. Su, "Synthesis of covert actuator and sensor attackers", *Automatica*, vol 130, 109714, 2021.
- [15] A. Khoumsi, "Sensor and actuator attacks of cyber-physical systems: a study based on supervisory control of discrete event systems", *Conference on Systems and Control*, pp. 176-182, 2019.
- [16] R. Su, "Supervisor synthesis to thwart cyber-attack with bounded sensor reading alterations", *Automatica*, vol. 94, pp. 35-44, 2018.
- [17] Q. Zhang, C. Seatzu, Z. Li, A. Giua, "Stealthy Sensor Attacks for Plants Modeled by Labeled Petri Nets", *Proc. 15th Int. Workshop Discrete Event Syst.*, pp. 14-20, 2020.
- [18] S. Zheng, S. Shu and F. Lin, "Modeling and Control of Discrete Event Systems under Joint Sensor-Actuator Cyber Attacks", *2021 6th International Conference on Automation, Control and Robotics Engineering (CACRE)*, pp. 216-220, 2021.
- [19] R. Su, "On decidability of existence of nonblocking supervisors resilient to smart sensor attacks", arXiv: 2009.02626v1, 2020.
- [20] R. Meira-Goes, H. Marchand, S. Lafortune, "Towards resilient supervisors against sensor deception attacks", *Proc. IEEE 58th Annu. Conf. Decis. Control (CDC)*, pp. 5144-5149, 2019.
- [21] R. Meira-Goes, S. Lafortune, H. Marchand, "Synthesis of supervisors robust against sensor deception attacks", *IEEE Trans. Autom. Control*, DOI 10.1109/TAC.2021.3051459, 2021.
- [22] Y. Wang, M. Pajic, "Attack-resilient supervisory control with intermittently secure communication," *Proc. IEEE 58th Annu. Conf. Decis. Control (CDC)*, pp. 2015-2020, Dec. 2019.
- [23] Y. Zhu, L. Lin, R. Su, "Supervisor obfuscation against actuator enablement attack", *European Control Conference*, pp. 1760-1765, 2019.
- [24] L. Lin, Y. Zhu, R. Su, "Towards bounded synthesis of resilient supervisors", *Proc. IEEE 58th Annu. Conf. Decis. Control (CDC)*, pp. 7659-7664, 2019.
- [25] L. Lin, R. Su, "Bounded synthesis of resilient supervisors", arXiv:1903.08358, 2021.
- [26] L. Lin, R. Tai, Y. Zhu, R. Su, "Observation-assisted heuristic synthesis of covert attackers against unknown supervisors", arXiv:2103.11197, 2021.
- [27] C. Cassandras, S. Lafortune, *Introduction to discrete event systems*, New York: Springer-Verlag, 2008.
- [28] R. Tai, L. Lin, Y. Zhu, R. Su, "Synthesis of covert sensor attacks in networked discrete-event systems with non-FIFO channels," arXiv:2103.07132, 2021.
- [29] J. E. Hopcroft, J. D. Ullman, *Introduction to automata theory, languages, and computation*, Addison-Wesley, Reading, Massachusetts, 1979.
- [30] Y. Zhu, L. Lin, S. Ware, R. Su, "Supervisor synthesis for networked discrete event systems with communication delays and lossy events", *Proc. IEEE 58th Annu. Conf. Decis. Control (CDC)*, pp. 6730-6735, 2019.
- [31] A. Bergeron, "A unified approach to control problems in discrete event processes", *RAIRO-Theoretical Informatics and Applications*, vol. 27, no. 6, pp. 555-573, 1993.
- [32] L. Lin, Y. Zhu, R. Tai, S. Ware, R. Su, "Networked supervisor synthesis against lossy channels with bounded network delays as non-networked synthesis", arXiv:2103.11273, 2021.
- [33] X. Yin, S. Lafortune, "Synthesis of maximally permissive supervisors for partially observed discrete event systems", *IEEE Trans. Autom. Control*, vol. 61, no. 5, pp. 1239-1254, 2016.
- [34] D. Wang, L. Lin, Z. Li, W. M. Wonham, "State-based control of discrete-event systems under partial observation", *IEEE Access*, vol. 6, pp. 42084-42093, 2018.
- [35] SuSyNA: Supervisor synthesis for non-deterministic automata. 2011 [Online]. Available: <https://www.ntu.edu.sg/home/rsu/Downloads.htm>.
- [36] L. Feng, W. M. Wonham, "Tct: A computation tool for supervisory control synthesis", *Proc. 8th Int. Workshop Discrete Event Syst.*, pp. 388-389, 2006.
- [37] R. Malik, K. Akesson, H. Flordal, M. Fabian, "Supremica—an efficient tool for large-scale discrete event systems", *IFAC-PapersOnLine*, vol. 50, pp. 5794-5799, 2017.
- [38] L. Lin, "Towards decentralized and parameterized supervisor synthesis", Ph.D thesis, School of Electrical and Electronic Engineering, Nanyang Technological University, 2015. [Online] Available: <https://dr.ntu.edu.sg/handle/10356/65641>.
- [39] R. Meira-Goes, R. H. Kwong and S. Lafortune, "Synthesis of optimal multi-objective attack strategies for controlled systems modeled by probabilistic automata", *IEEE Trans. Autom. Control*, doi: 10.1109/TAC.2021.3094737.



Ruochen Tai received the B.E. degree in electrical engineering from the Nanjing University of Science and Technology in 2016, and M.S. degree in automation from the Shanghai Jiao Tong University in 2019. He is currently pursuing the Ph.D. degree with Nanyang Technological University, Singapore. His current research interests include security issue of cyber-physical systems, multi-robot systems, safe autonomy in cyber-physical-human systems, formal methods, and discrete-event systems.



Liyong Lin received the B.E. degree and Ph.D. degree in electrical engineering in 2011 and 2016, respectively, both from Nanyang Technological University, where he has also worked as a project officer. From June 2016 to October 2017, he was a post-doctoral fellow at the University of Toronto. Since December 2017, he has been working as a research fellow at the Nanyang Technological University. His main research interests include supervisory control theory and formal methods. He previously was an intern in the Data Storage Institute, Singapore, where

he worked on single and dual-stage servomechanism of hard disk drives.



Yuting Zhu received the B.S. degree from Southeast University, Jiangsu, China, in 2016. She is currently pursuing the Ph.D. degree with Nanyang Technological University, Singapore. Her research interests include networked control and cyber security of discrete event systems.



Rong Su received the Bachelor of Engineering degree from University of Science and Technology of China in 1997, and the Master of Applied Science degree and PhD degree from University of Toronto, in 2000 and 2004, respectively. He was affiliated with University of Waterloo and Technical University of Eindhoven before he joined Nanyang Technological University in 2010. Currently, he is an associate professor in the School of Electrical and Electronic Engineering. Dr. Su's research interests include multi-agent systems, cybersecurity

of discrete-event systems, supervisory control, model-based fault diagnosis, control and optimization in complex networked systems with applications in flexible manufacturing, intelligent transportation, human-robot interface, power management and green buildings. In the aforementioned areas he has more than 220 journal and conference publications, and 5 granted USA/Singapore patents. Dr. Su is a senior member of IEEE, and an associate editor for *Automatica*, *Journal of Discrete Event Dynamic Systems: Theory and Applications*, and *Journal of Control and Decision*. He was the chair of the Technical Committee on Smart Cities in the IEEE Control Systems Society in 2016-2019, and is currently the chair of IEEE Control Systems Chapter, Singapore.