

# Online User Profiling to Detect Social Bots on Twitter

Maryam Heidari  
George Mason University

James H Jr Jones  
George Mason University

Ozlem Uzuner  
George Mason University

**Abstract**—Social media platforms can expose influential trends in many aspects of everyday life. However, the trends they represent can be contaminated by disinformation. Social bots are one of the significant sources of disinformation in social media. Social bots can pose serious cyber threats to society and public opinion. This research aims to develop machine learning models to detect bots based on the extracted user’s profile from a Tweet’s text. Online users’ profile shows the user’s personal information, such as age, gender, education, and personality. In this work, the user’s profile is constructed based on the user’s online posts. This work’s main contribution is three-fold: First, we aim to improve bot detection through machine learning models based on the user’s personal information generated by the user’s online comments. The similarity of personal information when comparing two online posts makes it difficult to differentiate a bot from a human user. However, in this research, we turn personal information similarity among two online posts as an advantage for the new bot detection model. The new proposed model for bot detection creates user profiles based on personal information such as age, personality, gender, education from user’s online posts, and introduces a machine learning model to detect social bots with high prediction accuracy based on personal information. Second, create a new public data set that shows the user’s profile for more than 6900 Twitter accounts in the Cresci 2017 [1] data set. All user’s profiles are extracted from the online user’s posts on Twitter. Third, for the first time, this paper uses a deep contextualized word embedding model, ELMO [2], for social media bot detection task.

**Index Terms**—Social Bots, Neural Network, Disinformation

## I. INTRODUCTION

Since social media is a place to exchange information, it is essential to differentiate between human posts and comments generated by bots. Bots intentionally spread information on these platforms to create a specific trend that could manipulate public opinion [3]. Social media platforms can be a rich source of user content, and user’s personal information can be disclosed in online platforms [4] and can be misused by social bots or Online fake identities to pose serious threats to financial organizations [5]. Bots can distribute fake news in social media and create disinformation in the society . Social media platforms can be the primary source of news and narratives about critical events in the world [6], and bots can significantly affect these events. Bots spread low-quality information and even misleading news, which can be hard to detect based on content. Social media bots can be created to target various audiences [1]. One study identified multiple types of spambots, including promoter bots, URL spam bots, and fake followers [1]. Promoter bots spend several months on promoting specific hashtags to create fake trends or

promote specific products [1]. For example, they can promote a sale on Amazon or help the political campaign to win an election [7]. URL spam Bots spread scam URL links by embedding them in retweets they create of legitimate users. Other types of bots include fake followers on social media and fake reviewers of specific products [1]. Many studies have attempted bot detection in recent years. For example, in one study, an unsupervised learning approach is used to detect bots that distribute malicious URL links using URL shortening services [8]. Based on this study, URL sharing bots use constant tweet duplication of legitimate users at a specific time to spread malicious URLs. Their results suggest that about 23 percent of accounts that use URL shortening services are bots. Another popular bot detection service is "Botmeter"<sup>1</sup>, which is a supervised learning approach to detect social bots. Botmeter uses metadata related to each twitter account, such as network features, user features, and temporal features, to feed the Random Forest classifier algorithm. Network features show how information diffusion happens among multiple groups of users. User features are user name, screen name, the creation time of account, and geographic location. Temporal features show patterns in a tweet’s time generation. The community detection approach in social media [9] is used to detect online activities of a group of online users who share similar ideas. For example, DeBot [10]–[12] is another bot detection service that uses the correlation of activities between different accounts. Application of the Benford’s law is used for bot detection by analyzing online behaviors of bots. One of the drawbacks of previous models is that we need different information about each user’s account, such as users’ features and network features, to differentiate a human account from a bot account. However, in real-world scenarios, we need to detect bot accounts in the early stage of posting comments on social media to prevent the spread of misinformation in online communities. In this work, we improve previous models for social media bot detection by using minimum information about each online user’s, which is an online post to detect Social Media bots. Another significant difference between our new model for bot detection and previous models is that we use a deep contextualized word representation method to represent each tweet’s text to preserve the online comments’ context. We use a different implementation of neural network models for bot detection since the successful application of neural network models in different real-life problems such

<sup>1</sup><https://blog.quantinsti.com/detecting-bots-twitter-botometer/>

as health [13], cyber security [4] [14] has been proved by different studies. In this research, For each user, personal information such as Personality, age, gender, and education are extracted based on the user’s online comments to create the user’s profile. This work detects social bots based on the user’s profile and provides a natural language processing approach for social media bot detection. In this work for word representation of each tweet’s text, we use the bidirectional LSTM model, which is trained by language models based on a large text corpus. Embedding from language models(ELMO) [2] provides us with a rich representation of each tweet’s text [15]. In previous studies by Kudugunta et al. [16], LSTM, and GloVe [17] are used for bot detection; They use the account level approach with a combination of metadata related to each user for bot detection. However, this research uses ELMO, a bidirectional LSTM model for the tweet’s text, to create contextualized word representations of tweets and extract the user’s profile from the online comments. The new model outperforms the previous bot detection models by creating multiple neural network models on the top of multilayer bidirectional LSTM models to extract different aspects of a tweet’s text for social media bot detection. This research also creates a new public data set that provides a user’s profile for more than 6900 Twitter accounts in the Cresci data set, and it will be available for public research in various aspects of social media network analysis.

## II. DATASET

The data set for this research is Cresci 2017 data set [1], [18], which is labeled data set of different types of bots and genuine(human) users. Table I shows different types of social media bots in the Cresci data set. There are five categories of social bots. Social Spam bots #1, which are 1000 automated accounts from the 2014 election in Rome. Social spam bots #2 who are promoter bots that spend several months on Twitter to promote specific hashtags on Twitter. Social spam bots #3 are fake followers who share spam URLs on Amazon to promote their products. Traditional spambots who distribute malicious URLs links or fraudulent job offers on Twitter. Fake followers that bought by Cresci authors from different websites. This research chooses Cresci 2017 data set since it includes different types of social spambots. In this data set, each account has the following attributes: follower-count, friends-count, retweet-count, reply-count, number of hashtags, number of shared URL, tweet text, screen name, and user ID. However, in this work, all features are extracted just based on the user’s online posts.

Bot purpose is mostly to distribute misinformation. [19]–[25].

Machine learning models have different applications in health, cyber security, business and social computing research [11], [12], [26], [27], [27]–[45]. In this work, our focus is in the fake news, and we do not detect other types of misinformation. We use COVID-19 data set for fake news detection model. We use transfer learning on COVID-19 tweet’s text to create a fake news detection model.

TABLE I  
CRESCI 2017 DATASET DESCRIPTION

user type	tweets	Accounts
genuine	2839361	3474
social spam bot #1	1610034	991
social spam bot #2	428542	3457
social spam bot #3	1418557	464
traditional spam bot	145094	999
fake followers	196027	3351

```
RT @apelike: SHARING! 72-Hour HERPES / COLD SORES / SHINGLES Treatment DISCREET! Visit Amazing Results! http:/ ...
RT thanks man! @semox74: http://t.co/GPMdqRmpTS ~
New blog post:
\\u0e40\\u0e23\\u0e37\\u0e48\\u0e2d\\u0e07
```

Fig. 1. Tweet Example

## III. DATA PREPROCESSING

Each tweet’s text quality can directly affect the tweet word embedding phase, which is used for different classification models and can have a negative effect on training the model. This work uses 284 human annotators who are provided by Amazon Sagemaker [46] to make an annotation for a new public data set of user’s profiles for more than 6900 Twitter accounts who post more than 4 million Tweets. Annotators are used to preprocessing the tweets and create the user’s profile by using TextGain<sup>2</sup>, which is a text-processing API tool that can be used for different text processing tasks such as information retrieval and semantic extraction. Figure 1 shows an example of unwanted characters such as unknown URL types or any characters which can not be removed from the text by using simple regular expression techniques in the text cleaning phase. These types of characters can cause classification errors in the bot detection model. Based on human annotators reports, the tweet’s text still has unknown URL types after cleaning the tweet texts. After further analysis by human annotators, and based on figure 1, we find that about 94% of the tweets that use URL shortening services in this data set also has the word ’blog’ in the tweet’s text. By adding the word ’blog’ to a customized regular expression, URLs created by URL shortening services are removed from the tweet’s text. On the other hand, the existence of the URL in a user’s tweet can be essential to detect bots from human accounts, so we add a new attribute to all twitter accounts with the name of URL, which is the indicator of the number of shared URLs by a Twitter account.

Figure 2 shows the results for gender distribution attributes before the pre-processing phase and figure 3 shows the results for gender attributes after data pre-processing by human annotators. The comparison of figure 2 and figure 3 shows the possible effect of text quality on the classification results. The

<sup>2</sup><http://textgain.com/>

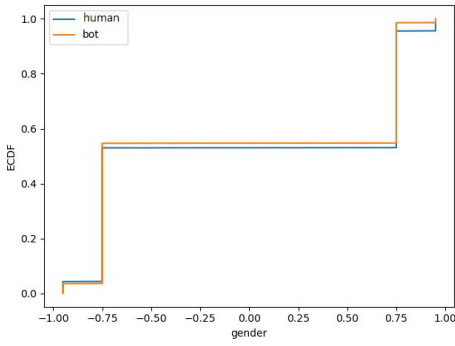

Fig. 2. Gender distribution between bot and human accounts

main reason for the difference between figure 2 and figure 3 is that API provides more accurate results about user's gender when it takes user's tweet's text one by one in comparison with taking all user's online comments at once. In this phase, we pass the user's tweets one by one to the API. For each tweet's text, three human annotators repeat the process and check the validation of the final results. This process is repeated for more than four million tweets in the data set. TextGain provides four different confidence numbers for each gender, age, personality, and education. Human annotators assign personality, age, gender, and education to one twitter accounts based on average confidence numbers of all tweets related to that Twitter account. In the user's profile, Online user's age has two categories: age under 25 years old or age over 25. User's gender can be male or female, user's education: educated and not educated, user's personality: introvert, extrovert.

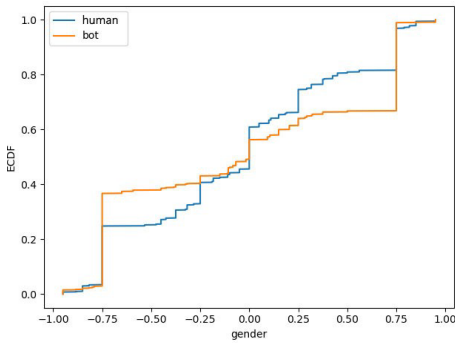

Fig. 3. Improved results for Gender distribution among bot and human accounts after preprocessing

This work creates a customized User interface application to extract the user's profile from a tweet's text. This software helps to customize TextGain API requests based on the text analysis needs and the classification algorithm results. This research will make this application available for the researchers to create an online user's profile for online cyber threat analysis and identity detection on social media research.

## IV. METHODS

The user's profile is added to all Twitter accounts based on the tweet's text in the data preprocessing phase. As shown in figure 3, the distribution of gender is very similar between a bot and a human account. So, attributes with similar values between two classes of bots and humans create obstacles in the bot detection process. For example, It is hard to differentiate between a bot comment and a human comment if both online posts show the same user's profile. However, in the continue, we propose a new bot detection model that turns this obstacle to the advantage for bot detection technique and maximizes the utilization of similar features between two class labels(bot, Human) to improve the bot detection algorithm's prediction accuracy. The new model uses the user's profile to improve prediction accuracy in social media bot detection algorithms.

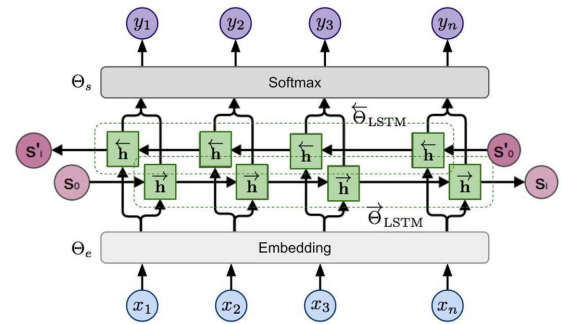

Fig. 4. ELMo<sup>3</sup>

This research uses both Glove(Global Vectors) and ELMO(Embedding from the language model) for word embedding of the tweet's texts to have a complete representation of each tweet's text for input space of bot detection model. Figure 4 shows the Elmo base model that is used in this work. As can be seen,  $(x_1, \dots, x_n)$ , shows the sequence of  $n$  tokens in the tweet's text. The bidirectional multi-layer LSTM uses the history of backward and forward tokens for each target token in a tweet's text. The history of backward tokens is calculated by:

$$p(x_1, \dots, x_n) = \prod_{i=1}^n p(x_i | x_1, \dots, x_{i-1}) \quad (1)$$

The history of forward tokens is calculated by:

$$p(x_1, \dots, x_n) = \prod_{i=1}^n p(x_i | x_{i+1}, \dots, x_n) \quad (2)$$

prediction in both directions by multi-layer LSTM can be modeled by hidden states  $\vec{h}_{i,l}$  and  $\overleftarrow{h}_{i,l}$  for the input token

abilities of token existence in the tweet's text. We fined tuned

<sup>3</sup><https://www.topbots.com/generalized-language-models-cove-elmo/>

the ELMO model<sup>4</sup> to minimize the negative log likelihood in both directions of LSTM model:

$$L = - \sum_{i=1}^n \log p(x_i | x_1, \dots, x_{i-1}; \Theta_e, \overrightarrow{\Theta}_{LSTM}, \Theta_s) + \log p(x_i | x_{i+1}, \dots, x_n; \Theta_e, \overleftarrow{\Theta}_{LSTM}, \Theta_s) \quad (3)$$

In the new social bot detection model, the Elmo model can capture the context of the tweet’s text.

Also, the statistics of the global English corpus for each token in a tweet’s text can be represented by GloVe in the word embedding phase.

In this work, at all experiments, Tweet’s text and original Crescie 2017 data set features are considered an input space for all classification models. First, we examine the effect of adding the user’s profile to the input pace of Neural network and logistic regression in the bot detection model. User’s age and user’s gender have similar distribution between bots and human accounts. Based on data labeling in the data preprocessing phase, each online user has a gender attribute that can be categorized as male or female and have age attributes that can be categorized as online users under age 25 or over age 25. In this section, we examine the effect of similar attributes among online users on Twitter in the bot detection model. Table II shows the results for logistic regression when the user’s gender is a new feature for bot detection. Table III shows logistic regression when the user’s age is new input for bot detection model.

TABLE II  
LOGISTICS REGRESSION BASED ON USER’S GENDER

Logistic Regression	Accuracy	f1 Score
without gender	0.783	0.774
with gender	0.794	0.791

TABLE III  
LOGISTICS REGRESSION BASED ON USER’S AGE

Logistic Regression	Accuracy	f1 Score
with age	0.793	0.803
without age	0.783	0.774

The prediction accuracy of the model by adding the user’s gender is 79%, and adding the user’s age is 78%. Comparison of Table II and Table III shows that the user’s gender in compared with user’s age have more positive effect in prediction accuracy of logistic regression model in bot detection task. However, adding a user’s age and gender improve bot detection accuracy by 1%, but we need more improvement in the bot detection model. So there is a need to implement another classification model to capture the real effect of the user’s profile in the bot detection model.

Then we examine the effect of the user’s age and user’s gender in prediction accuracy of the Neural network model. Two layers of feed-forward Neural network are designed for

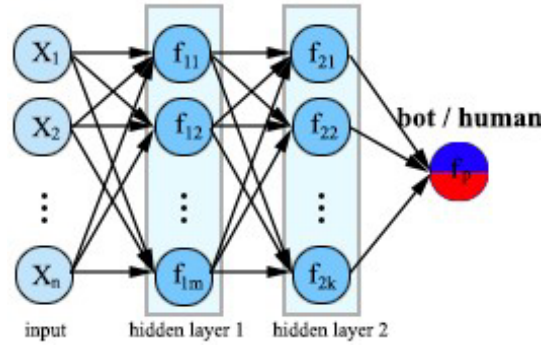

Fig. 5. FFNN

TABLE IV  
FFNN RESULTS BASED ON USER’S AGE AFTER

Algorithm	Accuracy	f1 score
FFNN with age	0.808	0.805
FFNN without age	0.807	0.803

bot detection. Figure 5 shows the FFNN model, for bot classification. Table IV shows the results of the FFNN model based on the user’s age. Table V shows the results by adding the user’s gender in the neural network model. Adding the user’s age and user’s gender as a new feature in the single neural network’s input space can not improve the prediction accuracy significantly. However, the Neural network model with an accuracy of 82% outperformed the logistic regression with an accuracy of 79% in bot detection by using the user’s gender. However, no significant difference in prediction accuracy can be seen by adding the user’s profile compared with when we do not add the user’s profile.

So in this work, the goal is to design a machine learning model that can use the user’s profile, which is very similar between class labels(bot and Human) and can detect bots with high prediction accuracy. This work introduces a model that can detect bot accounts, even if two accounts have a similar distribution in age, personality, education, and gender.

Figure 6 shows the new proposed bot detection model based on the user’s age. To improve the bot detection model’s prediction accuracy, by using an online user’s age, we design two different neural networks, one neural network to train data for users over age 25 and another neural network to train users under age 25. As can be seen in Table VI by implementing different neural networks for two age categories of online users, the prediction accuracy of the bot detection model improved by more than 3% in compare with Table IV when we train data related to online users regardless of user’s age category and just with one neural network model.

TABLE V  
FFNN RESULTS WITH RESPECT TO USER’S GENDER

Algorithm	Accuracy	f1 score
FFNN with gender	0.826	0.830
FFNN without gender	0.824	0.829

<sup>4</sup><https://github.com/allenai/allennlp>

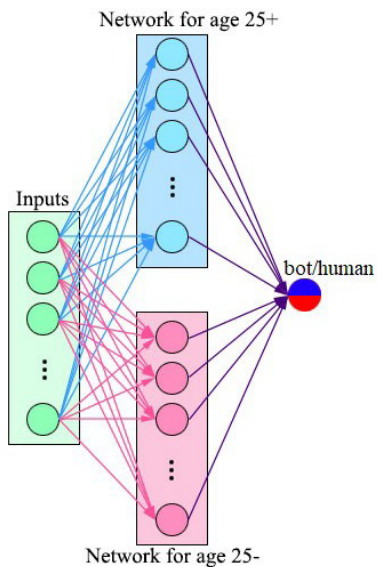

Fig. 6. Multiple Classification for age

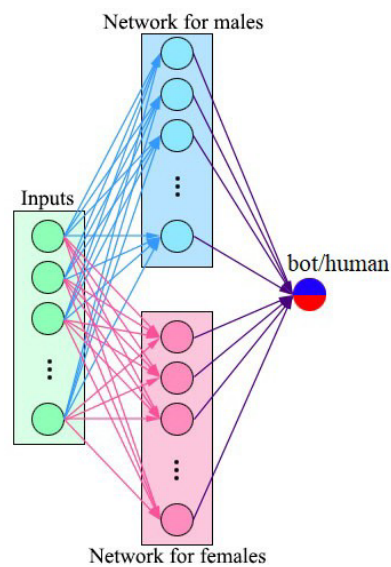

Fig. 7. Multiple Classification for gender

TABLE VI  
MULTIPLE CLASSIFICATION RESULTS BASED ON USER'S AGE AND GENDER

Algorithm	Accuracy	f1 Score
Multiple Classification with FFNN for Age	0.846	0.838
Multiple Classification with FFNN for Gender	0.860	0.868
The new proposed bot detection model in Figure 10	0.882	0.868

We repeat the same experiment for the user's gender as well. Figure 7 shows the proposed model to detect bot based on the user's gender. One neural network is trained based on female users, and one neural network is trained based on male users. In the female neural network, we have just female accounts, and it is the same in the male network. Table VI shows the results of the multiple classifications of male and female accounts for bot detection. As can be seen, the result shows a nearly 4% improvement in bot prediction accuracy compared with Table V when training male and female users data with one single neural network. Comparison between Table IV, Table V and Table VI shows that to detect bot accounts based on similar user's profile features such as age, gender, personality, and education, we need to implement and train multiple neural networks based on different categories of online user's age, gender, personality, and education. The multiple classification methods significantly affect the bot detection model's prediction accuracy, mainly when the input space of the classification model includes similar features among two class labels (bot, Human). Age, personality, education, gender have similar values among both bot and human accounts; however, with multiple classification models in this work and training the neural network separately for each attribute in the user's profile, we can solve this problem. In

our new model, multiple classification models are designed for Personality and Education, as same as age and gender. In the next section, the new bot detection model will be explained.

#### V. SAMPLE OF TWEETS AND ERROR ANALYSIS

This section shows a sample of tweets classified correctly and incorrectly by Logistic regression and multiple classification techniques. Red color shows tweets classified by logistic regression, and green color shows tweets classified by new proposed multiple classifications for bot detection based on the user's profile. Figure 8 shows the True positive samples and figure 9 shows false-positive samples for both multiple classification and logistic regression. Tweet classification results of each algorithm are compared side by side. Based on Figure 8, One interpretation of this figures is that for the tweets which have retweet sentiment such as RT@, which can be the indicator of retweet count, the logistic regression has better performance, and the number of tweets which includes @RT word can be seen more in True positive file for logistic regression.

On the other hand, in the false-positive sample for the multiple neural network classification, we can see more tweets, including @RT. The string "RT@" mostly shows retweeting of the specific tweets and can be extracted by simple string matching from a tweet's text. However, features such as age, gender, personality, and education can not be extracted directly from the tweets and have more semantic meaning than simple sentiment. So if the feature has a simple sentiment characteristic rather than a semantic meaning, the logistic regression can capture it better than a neural network model for bot detection. If the feature is distinctive between Bot and human, the logistic regression can capture it better than a neural network. However, if the tweet's text data becomes huge, and the feature becomes complicated semantically, the



```

@annafaith00 @katievxo no but ask anybody not white !! It benefits when your white and you can't tell me o
ther wise Cuz you don't know
@rodriguez_12 turn app! Seems like I'm the only who remembered your bday
. @hughmcbride good catch! I read his review but not that episode. See what I mean? I trust these writers.
RT @tinatbh: kinda wanna go on a date, kinda wanna get hit by a truck too
RT @OneStrangeNigga: Dude is a machine! Lol
RT @ddlovato: IT WAS BLUE AND BLACK.
RT @nbcbayarea: Earthquake warning system for $110? UC Berkeley professor says it can be done. via @hurd_hu
rd
@hellowmitchscott thanks lol
RT @TamNancyBinay: Followed @MichelleObama #inspiration

```

```

155 Follow neelas *- @laridsilvasouza @GabiMaruta
156 Doing this. Doing that. Thinking about connecting the dots.
157 Sometimes I can't figure designers out. It's as if they flunked human anatomy. --&gt; Erna Bombeck
158 I never expected to be anybody important. - Elvis Presley
159 Non ogni nube porta tempesta. William Shakespeare
160 RT @druggedvibes: Bloods & Crips can unite, but I still don't get a text back.
161 @somnambulant cal-1-for-nia, no doubt about it.
162 Our work is the presentation of our capabilities. - Johann Wolfgang Von Goethe
163 This season

```

Fig. 8. True positive(correctly classified tweets), red color is logistic Regression , green Multiple Classification Neural Network

```

ow to Recycle Different Types of Plastic: Dear EarthTalk: What is the deal with plastics recycling these da
ts? ..
test wishes tita Diane and tito Patrick *clap clap
ony will not drive me home until he finds a song he likes ??
Ik my mom hid the gym card. Whore
RT @bobscare: 4 years since Jade Goody passed away. #RIPJADE
e didn't believe in flying saucers until he tickled the waitress
reputation is the other fellow's idea of your character
ETE 4: (21:15) Quinta colonna #StaserainTV
UPER FOLLOW >>> @fernandodutraa @lucasroxoficial @brunacarolrem @jsaady
ot something to say about angel investing/angel investments? We\'u2019d love to hear from you!

```

```

11 @wikebutcher - hahahahaha
12 @xChrissiealsina @x_Fayeeeee__ @elizz_11 it is you
13 @chestnutvinegar think that's why the all-okinawa slate was so powerful, because it worked with the jcp an
was able to sweep.
Someone from work doing a charity trek to machu picchu... something tells me the flights and all would cost
ore than the money raised
15 @natties_daddy can we line the yard with railroad stuff?
16 @yungchano: I'm difficult.. Oh well get used to it.
17 @dnstoltz ugh he annoys me every day
18 @Dan_Ibanez betsy lets ppl do ll anyway u want it if theres nobody else in store. I h8 ppl so I say no
19 I'm so exhausted
@vineetbhatnagar I can use netflix here too I guess using Hola - never really tried though. Plus it's mor
20 f a jugaad available on browser

```

Fig. 9. False positive(incorrectly classified tweets), red color is logistic regression , green Multiple classifications neural network

neural network’s multiple classifications outperformed logistic regression. If features can not be observed by only looking at the tweet’s text, the neural network’s multiple classifications can achieve higher prediction accuracy for the bot detection model. Also, if the features are not very distinctive between humans and bots, like the user’s profile in this work, the multiple classifications of the neural network provide higher prediction accuracy than when we train all data by using a single neural network model for bot detection. Based on our knowledge, it could be one reason why multiple classifications outperformed logistic regression and simple FFNN for bot detection in this work since the user’s profile attributes can not be extracted from the text by simple sentiment analysis of tweet’s text and they have semantic meaning.

## VI. NEW BOT DETECTION MODEL

Figure 10 shows Our proposed model for social media bot detection. As can be seen, the first phase of the new model shows is word embedding of the tweet’s text. In this work, GLOVE and ELMO play an important role in the word embedding section, since without complete semantic representation of each tweet, adding the user’s profile such as age, gender, education, and personality for input space of the classification model is not effective. The bidirectional LSTM architecture of ELMO is one of the essential components in a new bot detection model. In the second phase, eight different neural networks are trained based on different features in the user’s profile. Based on what is discussed in the method section, training data in the neural networks should be in multiple steps, and implementing multiple classifications is key to improving bot prediction accuracy by using the user’s profile in the new model.

The last phase in Figure 10 of our new bot detection model is implementing a final classification model that can integrate the final results of all neural network models in the second phase. So the user’s profile, which shows age, gender,

TABLE VII  
COMPARE THE CLASSIFIERS

System	F1-Score	Accuracy	AUC/ROC
Random Forest	0.969	0.962	0.889
Logistic Regression	0.861	0.862	0.858
AdaBoost Classifier	0.954	0.959	0.942
FFNN	0.970	0.971	0.972
SGD Classifier	0.968	0.970	0.961

personality, and education of a user, is the input feature’s set for the final classifier in the new bot detection model. We examine different classifiers as a possible candidate for the final classifier. The new model of bot detection needs several experiments to choose the best classifier for the final phase. Table VII shows the results of the prediction accuracy of the bot detection model based on the user’s profile. It can be seen that adding the neural network model on the top of all FFNN models in the previous phase outperformed other classifiers in bot prediction accuracy. The results show that the FFNN model with 97% provides the best results for the bot detection model in the last layer of our new model compared with other classifiers. The Random forest provides high prediction accuracy very close to Feedforward neural network. In Table VI, the new model uses age, gender, personality, and education based on the tweet’s text. The results show that the new model increases the prediction accuracy by more than 3% compared with previous models and can achieve more than 88% accuracy on more than four million tweets in the Cresci data set. In the next section, we evaluate our new bot detection model compared with previous bot detection techniques based on the same test and training data.

## VII. PERFORMANCE EVALUATION

To evaluate our new model, We compare our new bot detection model with previous bot detection techniques in table VIII. The new model performance is examined based on

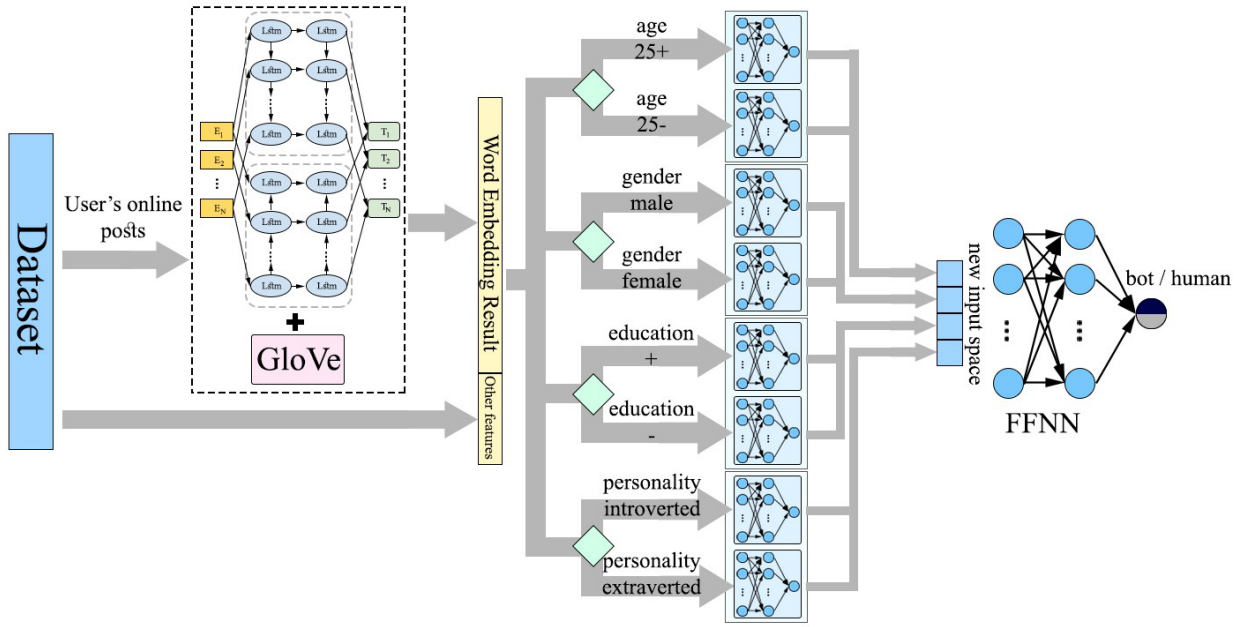

Fig. 10. Our proposed model for social bot detection

TABLE VIII  
PERFORMANCE COMPARISON BETWEEN NEW BOT DETECTION MODEL AND PREVIOUS BOT DETECTION TECHNIQUES [47]

technique	type	Accuracy	F-Measure	MCC
test set #1				
Davis et al. [48]	supervised	0.734	0.288	0.174
C. Yang et al. [49]	supervised	0.506	0.261	0.043
Miller et al. [50]	unsupervised	0.526	0.435	0.059
Ahmed et al. [51]	unsupervised	0.943	0.944	0.886
Cresci et al. [47]	unsupervised	0.976	<b>0.977</b>	0.952
<b>Our new model</b>	supervised	<b>0.981</b>	0.976	<b>0.962</b>
test set #2				
Davis et al. [48]	supervised	0.922	0.761	0.738
C. Yang et al. [49]	supervised	0.629	0.524	0.287
Miller et al. [50]	unsupervised	0.481	0.370	-0.043
Ahmed et al. [51]	unsupervised	0.923	0.923	0.847
Cresci et al. [47]	unsupervised	0.929	0.923	0.867
<b>Our new model</b>	supervised	<b>0.946</b>	<b>0.941</b>	<b>0.890</b>

the same training and test data set as previous bot detection techniques. The test set #1 is the mix of human and bot accounts in political campaigns, and test set #2 is a combination of human and spambots accounts in Amazon. The new model outperformed previous bot detection models by achieving nearly 94% prediction accuracy in bot detection in both test#1 and test set #2. The new proposed model's main advantage is detecting bot accounts when dealing with a massive amount of social media accounts with very similar characteristics in their user profile. The new proposed model can detect bot and human posts if they have the same age, education, gender, and personality. Also, using ELMO and GloVe model for word embedding of tweet's text provides a deep contextualized representation of each tweet's text, which is essential in the bot detection model's prediction accuracy based on the user's profile.

## VIII. CONCLUSION

The main contribution of this work can be summarized in four points. First, this research creates a public data set of online users' profiles for more than 6900 twitter accounts. This data set will be available for public research on social media and cyber threat analysis research. Second, using the user's profile, which has similar values between a bot and human accounts, detects bots in social media. The new proposed model in this work can detect bots accounts from human accounts, even if both accounts have the same user profile(education, Gender, Personality, age) are the same. Third, introducing a new bot detection model that can outperform previous bot detection techniques. Fourth, the new bot detection model uses a contextualized representation of each tweet by using ELMO and GLOVE in the word embedding phase, which is essential in achieving the high prediction accuracy in this model.

## REFERENCES

- [1] S. Cresci, R. D. Pietro, M. Petrocchi, A. Spognardi, and M. Tesconi, "The paradigm-shift of social spambots: Evidence, theories, and tools for the arms race," *CoRR*, vol. abs/1701.03017, 2017.
- [2] M. E. Peters, M. Neumann, M. Iyyer, M. Gardner, C. Clark, K. Lee, and L. Zettlemoyer, "Deep contextualized word representations," in *Proceedings of the 2018 Conference of the North American Chapter of the Association for Computational Linguistics: Human Language Technologies, NAACL-HLT 2018, New Orleans, Louisiana, USA, June 1-6, 2018, Volume 1 (Long Papers)* (M. A. Walker, H. Ji, and A. Stent, eds.), pp. 2227–2237, Association for Computational Linguistics, 2018.
- [3] M. Forelle, P. N. Howard, A. Monroy-Hernández, and S. Savage, "Political bots and the manipulation of public opinion in venezuela," *CoRR*, vol. abs/1507.07109, 2015.
- [4] A. Mosallanezhad, G. Beigi, and H. Liu, "Deep reinforcement learning-based text anonymization against private-attribute inference," in *Proceedings of the 2019 Conference on Empirical Methods in Natural Language Processing and the 9th International Joint Conference on Natural Language Processing (EMNLP-IJCNLP)*, (Hong Kong, China), pp. 2360–2369, Association for Computational Linguistics, Nov. 2019.
- [5] N. Yousefi, M. Alaghaband, and I. Garibay, "A comprehensive survey on machine learning techniques and user authentication approaches for credit card fraud detection," *arXiv preprint arXiv:1912.02629*, 2019.
- [6] T. A. Oghaz, E. c. Mutlu, J. Jasser, N. Yousefi, and I. Garibay, "Probabilistic model of narratives over topical trends in social media: A discrete time model," in *Proceedings of the 31st ACM Conference on Hypertext and Social Media*, HT '20, (New York, NY, USA), p. 281–290, Association for Computing Machinery, 2020.
- [7] P. N. Howard, S. Woolley, and R. Calo, "Algorithms, bots, and political communication in the us 2016 election: The challenge of automated political communication for election law and administration," *Journal of Information Technology & Politics*, 2018.
- [8] Z. Chen, R. S. Tanash, R. Stoll, and D. Subramanian, "Hunting malicious bots on twitter: An unsupervised approach," in *Social Informatics - 9th International Conference, SocInfo 2017, Oxford, UK, September 13-15, 2017, Proceedings, Part II* (G. L. Ciampaglia, A. J. Mashhadi, and T. Yasseri, eds.), vol. 10540 of *Lecture Notes in Computer Science*, pp. 501–510, Springer, 2017.
- [9] R. Abdolazimi, S. Jin, and R. Zafarani, "Noise-enhanced community detection," in *Proceedings of the 31st ACM Conference on Hypertext and Social Media*, HT '20, (New York, NY, USA), p. 271–280, Association for Computing Machinery, 2020.
- [10] N. Chavoshi, H. Hamooni, and A. Mueen, "Debot: Twitter bot detection via warped correlation," in *IEEE 16th International Conference on Data Mining, ICDM 2016, December 12-15, 2016, Barcelona, Spain*, pp. 817–822, 2016.
- [11] S. Zad, J. Jimenez, and M. Finlayson, "Hell hath no fury? correcting bias in the nrc emotion lexicon," in *Proceedings of the 5th Workshop on Online Abuse and Harms (WOAH 2021)*, pp. 102–113, 2021.
- [12] S. Zad and M. Finlayson, "Systematic evaluation of a framework for unsupervised emotion recognition for narrative text," in *Proceedings of the First Joint Workshop on Narrative Understanding, Storylines, and Events*, pp. 26–37, Association for Computational Linguistics, 2020.
- [13] M. Saadati, J. Nelson, and H. Ayaz, "Mental workload classification from spatial representation of fnirs recordings using convolutional neural networks," in *2019 IEEE 29th International Workshop on Machine Learning for Signal Processing (MLSP)*, pp. 1–6, IEEE, 2019.
- [14] F. Behnia, A. Mirzaeian, M. Sabokrou, S. Manoj, T. Mohsenin, K. N. Khasawneh, L. Zhao, H. Homayoun, and A. Sasan, "Code-bridged classifier (cbc): A low or negative overhead defense for making a cnn classifier robust against adversarial attacks," *arXiv preprint arXiv:2001.06099*, 2020.
- [15] S. Zad, J. Jimenez, and M. A. Finlayson, "The abbe corpus: Animate beings being emotional," *ArXiv*, vol. abs/2201.10618, 2022.
- [16] S. Kudugunta and E. Ferrara, "Deep neural networks for bot detection," *Inf. Sci.*, vol. 467, pp. 312–322, 2018.
- [17] J. Pennington, R. Socher, and C. D. Manning, "Glove: Global vectors for word representation," in *EMNLP*, vol. 14, pp. 1532–1543, 2014.
- [18] M. Heidari, "Nlp approach for social media bot detection(fake identity detection) to increase security and trust in online platforms," 2022.
- [19] M. K. Elhadad, K. F. Li, and F. Gebali, "Detecting misleading information on COVID-19," vol. 8, pp. 165201–165215, 2020.
- [20] M. Heidari and S. Rafatirad, "Using transfer learning approach to implement convolutional neural network model to recommend airline tickets by using online reviews," in *2020 15th International Workshop on Semantic and Social Media Adaptation and Personalization (SMA)*, pp. 1–6, IEEE, 2020.
- [21] M. Heidari and S. Rafatirad, "Semantic convolutional neural network model for safe business investment by using bert," in *2020 Seventh International Conference on Social Networks Analysis, Management and Security (SNAMS)*, pp. 1–6, IEEE, 2020.
- [22] M. Heidari, S. Zad, and S. Rafatirad, "Ensemble of supervised and unsupervised learning models to predict a profitable business decision," in *2021 IEEE International IOT, Electronics and Mechatronics Conference (IEMTRONICS)*, pp. 1–6, IEEE, 2021.
- [23] M. Heidari and J. H. Jones, "Using bert to extract topic-independent sentiment features for social media bot detection," in *2020 11th IEEE Annual Ubiquitous Computing, Electronics Mobile Communication Conference (UEMCON)*, pp. 0542–0547, 2020.
- [24] S. Zad, M. Heidari, J. H. Jones, and O. Uzuner, "A survey on concept-level sentiment analysis techniques of textual data," in *2021 IEEE World AI IoT Congress (AlloT)*, pp. 0285–0291, IEEE, 2021.
- [25] S. Zad, M. Heidari, H. James Jr, and O. Uzuner, "Emotion detection of textual data: An interdisciplinary survey," in *2021 IEEE World AI IoT Congress (AlloT)*, pp. 0255–0261, IEEE, 2021.
- [26] A. Esmailzadeh, "A test driven approach to develop web-based machine learning applications," UNLV Theses, Dissertations, Professional Papers, and Capstones, 2017.
- [27] A. Esmailzadeh and K. Taghva, "Text classification using neural network language model (nnlm) and bert: An empirical comparison," in *Proceedings of SAI Intelligent Systems Conference*, pp. 175–189, Springer, 2021.
- [28] M. Heidari, H. James Jr, and O. Uzuner, "An empirical study of machine learning algorithms for social media bot detection," in *2021 IEEE International IOT, Electronics and Mechatronics Conference (IEMTRONICS)*, pp. 1–5, IEEE, 2021.
- [29] M. Saadati, J. Nelson, A. Curtin, L. Wang, and H. Ayaz, "Application of recurrent convolutional neural networks for mental workload assessment using functional near-infrared spectroscopy," in *Advances in Neuroergonomics and Cognitive Engineering* (H. Ayaz, U. Asgher, and L. Paletta, eds.), (Cham), pp. 106–113, Springer International Publishing, 2021.
- [30] M. Heidari, S. Zad, B. Berlin, and S. Rafatirad, "Ontology creation model based on attention mechanism for a specific business domain," in *2021 IEEE International IOT, Electronics and Mechatronics Conference (IEMTRONICS)*, pp. 1–5, IEEE, 2021.
- [31] A. Esmailzadeh, J. R. Fonseca Cacho, K. Taghva, M. E. Z. N. Kamar, and M. Hajiali, "Building wikipedia n-grams with apache spark," in *Intelligent Computing*, Springer, 2022.
- [32] M. Heidari and S. Rafatirad, "Bidirectional transformer based on online text-based information to implement convolutional neural network model for secure business investment," in *2020 IEEE International Symposium on Technology and Society (ISTAS)*, pp. 322–329, IEEE, 2020.
- [33] A. Esmailzadeh, J. R. Fonseca Cacho, K. Taghva, M. E. Z. N. Kamar, and M. Hajiali, "Building wikipedia n-grams with apache spark," in *Intelligent Computing*, Springer, 2022.
- [34] P. Hajibabae, M. Malekzadeh, M. Heidari, S. Zad, O. Uzuner, and J. H. Jones, "An empirical study of the graphsage and word2vec algorithms for graph multiclass classification," in *2021 IEEE 12th Annual Information Technology, Electronics and Mobile Communication Conference (IEMCON)*, IEEE, 2021.
- [35] S. Zad, M. Heidari, P. Hajibabae, and M. Malekzadeh, "A survey of deep learning methods on semantic similarity and sentence modeling," in *2021 IEEE 12th Annual Information Technology, Electronics and Mobile Communication Conference (IEMCON)*, IEEE, 2021.
- [36] M. Malekzadeh, P. Hajibabae, M. Heidari, S. Zad, O. Uzuner, and J. H. Jones, "Review of graph neural network in text classification," in *2021 12th IEEE Annual Ubiquitous Computing, Electronics Mobile Communication Conference (UEMCON)*, IEEE, 2021.
- [37] J. Liu, M. Malekzadeh, N. Mirian, T. Song, C. Liu, and J. Dutta, "Artificial intelligence-based image enhancement in pet imaging: Noise reduction and resolution enhancement," *PET clinics*, vol. 16, no. 4, pp. 553–576, 2021.
- [38] D. Bamgboje, I. Christoulakis, I. Smanis, G. Chavan, R. Shah, M. Malekzadeh, I. Violaris, N. Giannakeas, M. Tsiouras, K. Kalafatakis, et al., "Continuous non-invasive glucose monitoring via contact



- lenses: Current approaches and future perspectives,” *Biosensors*, vol. 11, no. 6, p. 189, 2021.
- [39] A. Esmacilzadeh, M. Heidari, R. Abdolazimi, P. Hajibabae, and M. Malekzadeh, “Efficient large scale nlp feature engineering with apache spark,” in *2022 IEEE 12th Annual Computing and Communication Workshop and Conference (CCWC)*, pp. 0274–0280, 2022.
- [40] R. Abdolazimi, M. Heidari, A. Esmacilzadeh, and H. Naderi, “Mapreduce preprocess of big graphs for rapid connected components detection,” in *2022 IEEE 12th Annual Computing and Communication Workshop and Conference (CCWC)*, pp. 0112–0118, 2022.
- [41] M. Malekzadeh, P. Hajibabae, M. Heidari, and B. Berlin, “Review of deep learning methods for automated sleep staging,” in *2022 IEEE 12th Annual Computing and Communication Workshop and Conference (CCWC)*, pp. 0080–0086, 2022.
- [42] M. E. Z. N. Kamar, P. Nahed, J. R. F. Cacho, G. Lee, J. Cummings, and K. Taghva, “Clinical text classification of alzheimer’s drugs’ mechanism of action,” in *Proceedings of Sixth International Congress on Information and Communication Technology*, pp. 513–521, Springer, 2022.
- [43] P. Hajibabae, M. Malekzadeh, M. Ahmadi, M. Heidari, A. Esmacilzadeh, R. Abdolazimi, and J. H. J. Jones, “Offensive language detection on social media based on text classification,” in *2022 IEEE 12th Annual Computing and Communication Workshop and Conference (CCWC)*, pp. 0092–0098, 2022.
- [44] S. Zad, M. Heidari, P. Hajibabae, and M. Malekzadeh, “A survey of deep learning methods on semantic similarity and sentence modeling,” in *2021 IEEE 12th Annual Information Technology, Electronics and Mobile Communication Conference (IEMCON)*, pp. 0466–0472, 2021.
- [45] M. Esmail Zadeh Nojoo Kamar, A. Esmacilzadeh, Y. Kim, and K. Taghva, “A survey on mobile malware detection methods using machine learning,” in *2022 IEEE 12th Annual Computing and Communication Workshop and Conference (CCWC) (IEEE CCWC 2022)*, (virtual, USA), Jan. 2022.
- [46] “Amazon sagemaker ground truth.” <https://aws.amazon.com/sagemaker/groundtruth/>.
- [47] S. Cresci, R. D. Pietro, M. Petrocchi, A. Spognardi, and M. Tesconi, “Dna-inspired online behavioral modeling and its application to spambot detection,” *IEEE Intell. Syst.*, vol. 31, no. 5, pp. 58–64, 2016.
- [48] C. A. Davis, O. Varol, E. Ferrara, A. Flammini, and F. Menczer, “Botornot: A system to evaluate social bots,” in *Proceedings of the 25th International Conference on World Wide Web, WWW 2016, Montreal, Canada, April 11-15, 2016, Companion Volume*, pp. 273–274, 2016.
- [49] C. Yang, R. C. Harkreader, and G. Gu, “Empirical evaluation and new design for fighting evolving twitter spammers,” *IEEE Trans. Information Forensics and Security*, vol. 8, no. 8, pp. 1280–1293, 2013.
- [50] Z. Miller, B. Dickinson, W. Deitrick, W. Hu, and A. H. Wang, “Twitter spammer detection using data stream clustering,” *Inf. Sci.*, vol. 260, pp. 64–73, 2014.
- [51] F. Ahmed and M. Abulaish, “A generic statistical approach for spam detection in online social networks,” *Comput. Commun.*, vol. 36, no. 10-11, pp. 1120–1129, 2013.