

## Safe AI – How is this possible?<sup>1</sup>

Harald Rueß

fortiss  
Research Institute of the Free State of  
Bavaria for Software-Intensive Systems

ruess@fortiss.org

Simon Burton

Fraunhofer  
Institute for Cognitive Systems

simon.burton@iks.fraunhofer.de

Munich, 19<sup>th</sup> January 2022

*“As we know,  
there are known knowns.  
There are things we know  
we know.  
We also know  
there are known unknowns.  
That is to say  
we know there are  
some things we do not know.  
But there are also unknown unknowns,  
the ones we don’t know,  
we don’t know.”*

Donald Rumsfeld, Feb 2002, US DoD news briefing

---

<sup>1</sup> This work is funded by the Bavarian Ministry for Economic Affairs, Regional Development and Energy as part of the fortiss AI Center and a project to support the thematic development of the Fraunhofer Institute for Cognitive Systems. We are also grateful to Carmen Cârlan and Henrik Putzer for their thorough remarks and suggestions for improvement; in particular, Figure 2 is due to Carmen.

## Table of Content

<b>1. INTRODUCTION .....</b>	<b>3</b>
<b>2. SPECIFICATION .....</b>	<b>12</b>
SYSTEM SAFETY SPECIFICATION.....	12
COMPONENT SAFETY SPECIFICATIONS .....	13
DERIVING COMPONENT SAFETY SPECIFICATIONS .....	14
COMPONENT SAFETY VERIFICATION.....	16
<b>3. UNCERTAINTY .....</b>	<b>17</b>
UNCERTAINTY ABOUT THE ENVIRONMENT .....	18
BEHAVIORAL UNCERTAINTY OF LEARNING-ENABLED COMPONENTS .....	19
PROPAGATION OF UNCERTAINTY: FROM FAULTS TO FAILURES .....	20
ASSURANCE-BASED ESTIMATION OF UNCERTAINTY .....	20
<b>4. ANALYSIS .....</b>	<b>24</b>
TESTING .....	24
SYMBOLIC VERIFICATION.....	27
RUNTIME VERIFICATION .....	27
<b>5. SAFETY-BY-DESIGN .....</b>	<b>30</b>
PROPERTY-DRIVEN SYNTHESIS OF LEARNING-ENABLED COMPONENTS .....	30
COMPOSITIONAL SYSTEM DESIGN .....	31
<b>6. CONCLUSIONS .....</b>	<b>34</b>
<b>REFERENCES .....</b>	<b>36</b>

## 1. Introduction

A new generation of increasingly autonomous and self-learning *cyber-physical systems* (CPS) is being developed for control applications in the real world. These systems are AI-based in that they leverage techniques from the field of Artificial intelligence (AI) to flexibly cope with imprecision, inconsistency, incompleteness, to have an inherent ability to learn from experience, and to adapt according to changing and even unforeseen situations. This extra flexibility of AI systems makes it harder to predict their behavior.

Moreover, AI systems usually are safety-critical in that they may be causing real harm in (and to) the real world. Consequently, the central question regarding the development of such systems is how to handle or even overcome this basic dichotomy between unpredictable and safe behavior of AI systems. In other words, how can we best construct systems that exploit AI techniques, without incurring the frailties of “AI-like” behavior? (Rushby, Quality measures and assurance for AI software, 1988)

Consider, for example, an automated emergency braking system for a car that continually senses the operational context based on AI machine learning, assesses the current situation via an AI decision module based on models of the operational context (and itself), and initiates a maneuver for emergency braking by overriding the human driver, when necessary. The intent of this emergency maneuver is, of course, to prevent accidents in time-critical situations which the human operator may not be able to control anymore. The emergency braking maneuver itself is also safety-related, as wrongful execution might cause severe harm.

The *safe AI* challenge is not exactly new (Rodd, 1994) and may well be traced back to Turing himself in the early 1950s. Still, it has recently become all-important due to the euphoric mood on AI, as the acceptance and the success of AI techniques for real-world applications hinges on a meaningful, dependable, and safe control. On-going discussions about the responsible deployment of AI in the real world range from human-centered social norms and values<sup>2</sup> to their robust and safe realization (Amodei, et al., 2016) (Bhattacharyya, Cofer, Musliner, Mueller, & Engstrom, 2015).

In this thought outline, however, we restrict ourselves to the design principles for safe AI systems as a necessary step for the responsible deployment of mission- and safety-critical AI systems into our very societal fabric. Even though we are concentrating here on safety aspects only, we believe that there is also a fruitful intersection of the suggested approach with related attributes such as security, privacy, inverse privacy, contextual integrity, fairness, and transparency of AI systems.

---

<sup>2</sup> <https://www.ai4europe.eu/ethics>

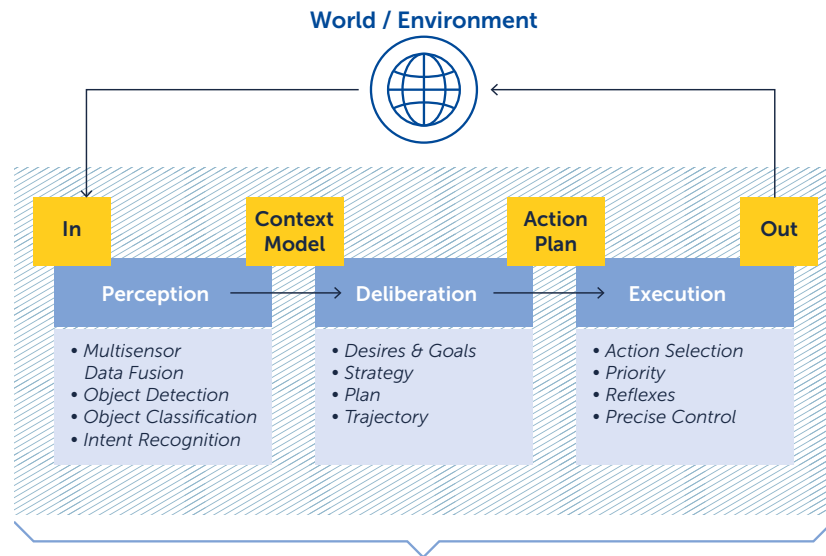

**Figure 1.** Sense-Plan-Act Loop.

The starting point of our considerations is the basic *sense-plan-act* loop in Figure 1 for controlling a plant based on monitored observations of the operational environment (including the controlled plant), perception, and interacting commands from human operators. Functionally automated driving systems, such as the emergency braking example, may easily be viewed as instances of this *sense-plan-act* loop, where the ego car is the plant to be controlled.

The *sense-plan-act* loop in Figure 1 is conceptually a function taking sensing inputs and generating corresponding output actions, which is usually also based on internal state. Whereas such a loop may be used as the conceptual specification of a reactive CPS (Geisberger & Broy, 2015), it is also the central technical concept of the field of AI, which is concerned principally with designing the internals of stream-transforming controls for mapping from a stream of raw perceptual data to a stream of actions.

Behavior generation for the sense-plan-act loop is decomposed into successive stages for situational awareness, followed by deliberate, goal-oriented planning, and by execution of selected actions in the real world. Sensing functionalities, in particular, are currently often realized through data-driven machine learning methods such as artificial neural networks (ANNs). Behavioral planning capabilities, on the other hand, are usually realized by more traditional software-based control methods, but also through probabilistic and reinforcement-based synthesis of control strategies. Such a conceptual separation into sensing and deliberate planning is supported, among others, by *global workspace theory*, which categorizes cognitive capabilities into fast and slow modes of operation: System 1 operates rapidly, intuitively, and effortlessly, whereas System 2 requires concentration,

motivation, and the application of learned rules, and it allows us to grasp the right ones.<sup>3</sup> In other words, System 1 means snap judgements which seduce us with the wrong answers, and System 2 means thinking twice (Pinker, 2021).

The context model of our running example, automated emergency braking, might consist of the positions, bounding boxes, and motion vectors of surrounding environment objects such as cars or cyclists. The *sensing* stage constructs and updates faithful models,<sup>4</sup> based on perceived inputs and other knowledge sources, of both the exogenous operating environment and the endogenous *self*. One can easily imagine scenarios in which failure of detection, misclassification, or imprecision in models is the cause of an accident. The main challenge therefore is to provide a convincing argument that an AI system is *sufficiently safe* as determined through applicable risk and safety analysis. As usual, this notion of *sufficiently safe* heavily depends on the specific societal context and, correspondingly, acceptable risks.

For our purposes, automated emergency braking, say, EB is intuitively said to be *safe* if its activation prevents, at least up to some tolerable quantity, accidents in prescribed situations. Assuming we can identify a corresponding subset  $S$  of “known” safe states of the operating context, the *safety envelope*, then the safety challenge for EB reduces to verifying the safety invariant  $EB(S) \subseteq S$ . In this way, emergency braking EB, when initiated in a potentially unsafe and uncontrollable (for the driver) state in  $S$ , produces safe control actions, in that the ego car is always maneuvered towards a safe and controllable state, possibly a fail-safe state, and as the basis for a possible handover to the driver. As with most CPS, ensuring safe autonomous control involves a rather complex interaction of uncertain sensing, discrete/probabilistic computation, physical motion, and real-time combination with other systems (including humans). We are arguing that traditional safety engineering techniques for embedded systems and CPS is not applicable to autonomous and self-learning AI systems acting in open environments – for the multitude of heterogeneous sources of uncertainty for these systems.

The inductive capability of machine learning, in particular, for extracting models from data is inseparably connected with uncertainty. There are many other sources of uncertainty in an AI system, as there is uncertainty about the operating context, there is uncertainty about the models of the operating context and the “self”, there is behavioral uncertainty due to the approximate nature of heuristic learning algorithms, there is uncertainty due to probabilistic and non-deterministic components, there is uncertainty about safety hazards,<sup>5</sup> there is uncertainty about safety envelopes in uncertain operating contexts, there is uncertainty on a meaningful fallback to a responsible human operator, and, finally, there is also uncertainty in

---

<sup>3</sup> Notice, however, that there are exceptions to this suggested separation-of-means, such as Nvidia’s end-to-end-control for an experimental self-driving systems (Bojarski, et al., 2016).

<sup>4</sup> So-called digital twins.

<sup>5</sup> For instance, dynamic hazards such as the sudden occurrence of objects on the road which may lead to catastrophic failure.

self-learning systems about their emergent behavior in time. Possibly the only thing that is certain about an AI system is that it is uncertain and largely unpredictable.

Let's investigate sources of uncertainty of machine learning components such as artificial neural networks (ANNs) in more detail. The input-output behavior of ANNs heavily relies on the selection of "complete" and "correct" sets of training and support data for faithfully specifying relevant operating contexts (input) and their intended internal representation (output). Another source of uncertainty for these machine learning algorithms is due to the use of stochastic search heuristics, which may lead to incorrect recall even for inputs from the training data, and the largely unpredictable capability of generalizing from given data points. Uncertainty on the faithfulness of the training data representing operating contexts and uncertainty on the correctness and generalizability of training also combine in a, well, uncertain manner. The consequences of these accumulated uncertainties are profound. Particularly, ANNs are usually not robust on unseen inputs, as there is also quite some uncertainty on the behavior on even small input changes.<sup>6</sup>

Adequate approaches are needed for measuring (un)certainly of the input-output behavior of an ANN with respect to the real world. For example, how certain are we that a given ANN correctly classifies homeomorphic images of a "cat"? How certain should an ego vehicle be that there are no surprises, such as undetected or misclassified vehicles, before initiating an emergency brake? Based on these certainty measures, internal models of the operating context should be equipped with confidence levels or, more generally, confidence intervals or distributions. The emergency braking assistant, for example, may, as the basis for selecting appropriate action, assign confidence levels for the position and mobility vectors of all relevant objects; possibly together with a confidence level that objects have been correctly identified and classified and that there are no "ghost" objects in the context model.

Traditional safety engineering ultimately is based on fallback mechanisms to a responsible human operator, deterministic behavior of the cyber-physical system as the basis for its testability, and well-defined operating contexts. In addition, current safety certification regimes require correct and complete specifications prior to operation. These basic assumptions of safety engineering do not hold anymore for AI systems, as:

1. With increased autonomy a fallback mechanism to a human is often not possible anymore. Indeed, the emergency braking system needs to perform without any human intervention as the required reaction times are well below the capabilities of human beings.
2. AI systems make their own knowledge-based judgements and decisions. While added flexibility, resilience, elasticity, and robustness of autonomous systems are clearly

---

<sup>6</sup> For instance, "one pixel attacks" for fooling deep neural networks (Su, Vargas, & Sakurai, 2019).

important, the gains in these dimensions come at the loss of testability due to the admittance of non-determinism.<sup>7</sup> This is a high price to pay, since systematic testing and simulation currently still is the single most used technique for verifying the correct functioning of software-intensive systems.

3. AI systems need to cope with operating environments that cannot be comprehensively monitored and controlled, and in which unpredictable events may occur. In fact, the main reason of using AI systems is for those situations where the full details of the operating context cannot be known ahead of time. It is therefore difficult to carry out risk estimation for AI systems using conventional techniques.

For all these reasons, well-established and successful safety standards for software-intensive systems, including DO 178C in aerospace and ISO 26262 in the automotive industry, cannot readily be applied to AI systems. Indeed, these safety standards pay little attention to autonomy and to the particularly advanced software technologies for system autonomy (Blanquart, et al., 2003).

There are many on-going industrial initiatives for developing, for example, low-level functionally automated driving<sup>8</sup> and certified AI algorithms in the medical domain.<sup>9</sup> These endeavors, however, are incomplete in that they are based on prescriptive safety standards.<sup>10</sup> But we still need to figure out adequate methodologies and end-to-end verification technology for assuring safe autonomy. And we also need to gain more practical experience on these approaches before prescribing them as “good” or even “best” practice in industrial standards. Current safety engineering standards are also based on the idea that the correct behavior must be completely specified and verified prior to operation. It is therefore unclear if and how these safety standards may apply to learning-enabled systems, which are continuously self-adapting and optimizing their behavior to ever-changing contextual conditions and demands, based on their experience in the field.

If current safety engineering methodology are not directly applicable to AI systems, then we might ask ourselves if we can at least reduce problems of safe autonomous and learning-enabled control on a case-by-case basis; for example:

---

<sup>7</sup> A NASA study of a software-based control of vehicle acceleration, for example, revealed, among others, potential race conditions in sensor readings due to asynchronous access by a multiplicity of threads. This study concluded that the software was “untestable”, making it impossible to rule out the possibility of unsafe control actions (NASA Engineering and Safety Center, 2011).

<sup>8</sup> Safety First guidance for potential methods and considerations with intention of developing safe L3-L4 automated driving functionality including ANN (Aptiv, et al., 2019).

<sup>9</sup> <https://www.fda.gov/medical-devices/software-medical-device-samd/artificial-intelligence-and-machine-learning-aiml-enabled-medical-devices#resources>

<sup>10</sup> “If you do ... then the system will be safe.”

1. Depending on the application context, safety engineers can restrict AI-based functionality with the intent of increasing controllability or decreasing severity/exposure, thereby decreasing associated safety risks.
2. Uncertainty due to open-ended operating contexts and safe control thereof is dramatically reduced in current automotive practice, by collecting all kinds of possible driving scenarios by means of global ecosystems of vehicles – both real and virtualized.<sup>11</sup> This approach basically tries to close-off the set of possible driving scenarios as the basis for constructing the equivalent of a “digital rail”. Due to the large number of possible anomalies (“black swans”),<sup>12</sup> however, this approach is rather resource-intensive, and it is unclear how to determine that enough scenarios have been collected to sufficiently cover the space of all driving scenarios.
3. AI-based functionality is complemented by a safe control channel, thereby effectively combining the intended performance of AI-based systems with the safety of more traditional control.<sup>13</sup> The crucial element in such a safety architecture is a switch between the performant AI-based channel and the safe channel, which is based on run-time monitoring of crucial safety specifications. A pervasive runtime monitor, for example, checks that the proposed action of *EB* yields safe behavior. Such a pervasive runtime monitor together with the switching logic between the two channels is developed with traditional safety engineering methods, thereby effectively removing AI component from a safety-critical path.
4. An engineer may also decide to discontinue initial AI-based proof-of-concepts by reverting to well-understood control techniques altogether; for example, if an end-to-end safety concept for the given AI-based functionality is too costly or not possible, and if a sufficiently performant and safe system may be achieved by more traditional means. The underlying phenomenon of *technical debt* for data-driven systems in real-life engineering has already been described previously (Sculley, et al., 2014).

Based on these kinds of engineering design decisions for reducing the safety relevance of AI systems and for increasing its determinacy, it may at times be possible to responsibly use traditional prescriptive safety engineering techniques also for AI. However, this reductionist approach is restricted to a rather small class of functionally automated systems with some added machine learning-based capabilities, which do not adequately support the key concepts of AI systems, namely, autonomy and self-learning. Methods for reducing safe AI problems to

---

<sup>11</sup> For example, <https://www.pegasusprojekt.de/en/home>

<sup>12</sup> A well-known example is the fatal crash of a car in autonomous mode that resulted from a very rare four-factor combination of a white truck against a brightly lit sky, along with truck height and angle versus the car  
(<https://www.tesla.com/blog/tragicloss>, <https://www.nts.gov/news/press-releases/Pages/PR20170912.aspx>)

<sup>13</sup> This is sometimes called a “Simplex” architecture.



the currently prevailing prescriptive safety engineering standards therefore are not future proof,<sup>14</sup> since prescribed and fixed verification and validation process activities, criteria, and metrics does not work well for assuring the safety of AI systems (Alves, et al., 2018).

Overarching Properties (Holloway, 2018) have recently been proposed as a product-based alternative to prescriptive safety engineering standards such as DO 178C. Informally, a system is safe for operation if and only if the CIA conditions hold:

- 1) the system does what it is supposed to do under foreseeable operating conditions (**C**orrectness);
- 2) what the system is supposed to do is properly captured (**I**ntent); and
- 3) the system does not cause unacceptable harm (**A**ceptability).

An assessment of whether a system possesses these properties might be based on an explicit assurance case.<sup>15</sup> Overarching properties therefore are flexible enough to be adapted to developing justified belief of system safety with learning-enabled components. As of now, however, the overarching CIA properties do not seem to have been adopted for safety certification on a larger scale.

All taken together, traditional safety engineering is coming to a turning point moving from deterministic, non-evolving systems operating in well-defined contexts to self-adaptive and self-learning systems which are acting largely autonomously and in largely unpredictable operating contexts. But we currently do not have an adequate safety engineering framework for designing this upcoming generation of autonomous and self-learning AI systems.<sup>16</sup>

In the following we therefore outline a novel approach for safe AI engineering. It is based on uncertainty quantification for the multitude of sources of uncertainties of AI systems. The overarching goal of managing uncertainties is to minimize uncertainty in the system behavior, thereby increasing confidence, up to tolerable levels, in the safe behavior of the AI system.

The underlying idea is to generalize the notion of *determinacy* in traditional safety engineering to *uncertainty*. Particularly, if there is no uncertainty on the behavior of some system, then it is fully predictable and deterministic. Deterministic parts of an autonomous system can (and probably should) therefore still be developed with well-proven design and verification techniques for establishing correctness and possible perfection.

Instead of fallback to responsible (human) operators, uncertainty measures are used by autonomous control strategies for minimizing surprises and for safely exploring largely

---

<sup>14</sup> The applicability and limits of prescriptive safety standards to autonomous AI systems is also discussed in (Salay & Czarniecki, 2018).

<sup>15</sup> See also Subsection *Assurance-based estimation of uncertainty*.

<sup>16</sup> See, for example, (Tamboon, Laberge, An, Nikanjam, & et.al., 2021) for a survey on safety certification of systems with learning-enabled components.

unknown territory. The emergency braking assistant, for example, might be rather uncertain on the precise location of some relevant car, and it therefore initiates additional perceptive capabilities with the intent of decreasing uncertainty, thereby increasing its confidence, on the location of the respective car to a sufficient level; as the basis for deciding on a safe sequence of emergency braking actions. Moreover, some indirect *cues* (Björkman, 1994) cause the system to hypothesize the existence of a relevant car, which, needs to be confirmed by additional actions before initiating emergency braking. These examples demonstrate that uncertainty is not only a design but also an essential runtime artifact for the situational generation of safe control behavior.

Uncertainties in the proposed engineering framework are explicitly managed through *safety cases*. These are structured arguments, supported by a body of evidence that provides a compelling, comprehensible, and valid case that a system is safe for a given application and operating environment.<sup>17</sup> In contrast to largely *process-based* traditional prescriptive approaches, a safety argument based on safety cases is largely *product-based*. As it involves the presentation of evidence that the actual developed system is safe, as opposed to merely showing that it was developed using normatively prescribed “good” practice. Recent quantitative extensions to safety and assurance cases provide the basis for assigning and combining uncertainties for the central ingredients, such as evidence, arguments, assumptions, and conclusions.

Figure 2, for example, illustrates the top-level plan for constructing a safety case for an autonomous GNC,<sup>18</sup> which is built upon a traditional 3-level autonomous architecture. The modular construction of this safety case is based, among others, on evidence from traditional verification of planning components, verification of the correctness or quasi-predictability of neural network components for perceptive tasks, and runtime monitoring for central safety properties. This GNC also includes an FDIR<sup>19</sup> component for detecting and for recovering from unforeseen and potentially hazardous events. The overall goal is to develop an autonomous spacecraft, say, for landing on an asteroid together with a complete safety case. And the safety case is also used in generating safe landing behavior and safely handles unforeseeable events.

---

<sup>17</sup> Def Stan 00-56 Issue 3, Safety Management Requirements for Defence Systems, Ministry of Defence, 2007.

<sup>18</sup> Guidance, Navigation, and Control

<sup>19</sup> Failure Detection, Isolation, and Recovery

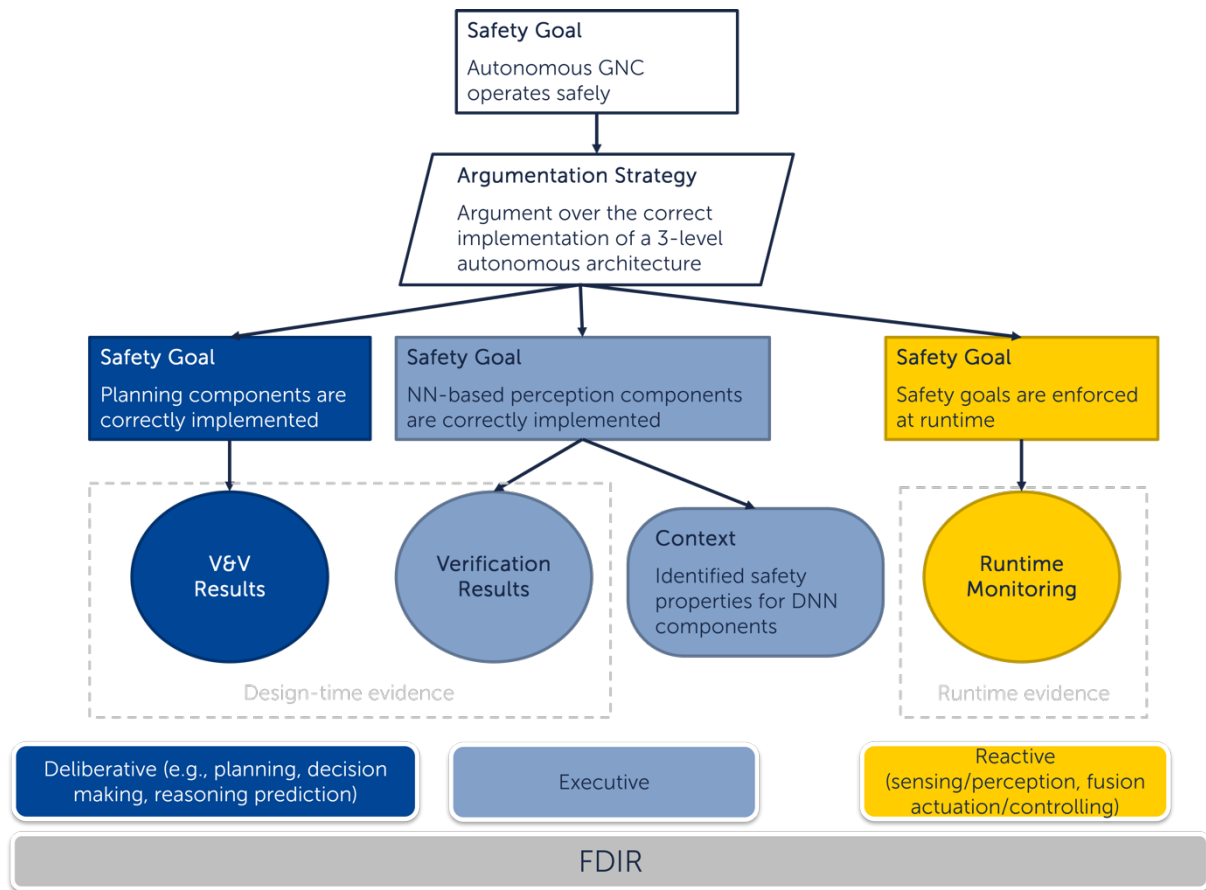

**Figure 2.** Outline for constructing a safety case from a 3-layer deliberation-execution-reaction architecture.

We identify central specification, uncertainty, assurance, design, analysis, and maintenance challenges for realizing such a rigorous design of safe AI; all based on the notion of managing uncertainty to acceptable levels.<sup>20</sup> An overview on these challenges is provided in Table 1.

We also hint at possible research directions and challenges – without claiming completeness. At times this exposition may seem rather sketchy and speculative, and clearly, many of our claims and hypotheses need further substantiation or disproval. In this sense, this thought outline is supposed to be a living document, which needs to be updated and concretized as we gain more experience and increase our theoretical understanding on rigorous engineering techniques for safe AI – as the basis for the responsible and safe deployment of AI in the real world.

<sup>20</sup> In analogy to the “as low as reasonably possibly” (ALARP) risk-based criterion we might call this the “as certain/confident as reasonably possibly” (ACARP) principle.

## 2. Specification

In a first step we need to express in precise terms when an AI system may be considered safe. This sounds easier than it is, since data-driven AI is particularly successful in application contexts for which it is difficult, if not impossible, to come up with concise specifications (say, translation of natural language). Also operating contexts of AI systems typically are complex, uncertain, and largely unpredictable. Safety hazards are subject to change during operation, and the presence of human operators and their interaction with the sense-plan-act control loop further complicates matters in that even well-intended human interaction may lead to unsafe behavior. In summary, the adaptive, flexible, and context-sensitive behavior of AI systems causes unpredictability and emergent unsafe behavior, which was not necessarily specified, intended, or consciously implemented during system design.

In the following we distinguish between safety specifications of AI systems and derived specifications of learning-enabled components of these systems. And we also discuss ways for systematically deriving requirements for individual components of the system from overall safety requirements.

### System Safety Specification

The overall system's safety specification is often described in terms of safety envelopes. These envelopes may be thought of as under-approximation of the states (or scenarios) of possible operating contexts that are sufficiently safe.<sup>21</sup> In a slightly more general setting, we also quantify uncertainty of environment states.

A common approach for specifying safety envelopes is based on maximizing under-approximations, thereby also maximizing the number of known safe behaviors. In other words, the operating context is partitioned into known safe (the safety envelope), the known unsafe, the unknown safe, and the unknown unsafe, and the goal is to maximize the known safe areas by minimizing the known unsafe areas and discovering as many new unsafe scenarios as possible with a given level of effort (SOTIF, 2017).<sup>22</sup> And then, there is one more thing, as safety envelopes need to be continually adapted to ever-changing operating contexts, safety hazards, and safety requirements.

The safety objective of the automated emergency braking system, for example, is to maintain a minimum safe distance between the ego car and environment objects. More generally, the Responsibility-Sensitive Safety (RSS) model offers provable safety for vehicle behaviors such as minimum safe following distance (Shalev-Schwartz, Shammah, & Shashua, 2018). Safety envelopes such as RSS have also been extended to deal with worst-case variability and

---

<sup>21</sup> According to a risk and safety analysis of the system under consideration

<sup>22</sup> A newer version is available at <https://www.beuth.de/de/norm-entwurf/iso-dis-21448/335355102>

uncertainty (Koopman, Osyk, & Weast, 2019). Safety envelopes usually are highly non-linear and context dependent as is the case for Kamm's friction ellipses. In these cases, machine learning techniques based on minor component analysis are promising for synthesizing safety envelopes from safe behaviors (Tiwari, et al., 2014). These techniques open the possibility of self-learning and safe maintenance of safety envelopes through cautious<sup>23</sup> and safe exploration.

We still have very little knowledge on how to systematically construct safety envelopes. The challenge therefore is to construct and maintain safety envelopes, that is known safe states, of the operational context, and to maximize the safety envelope with a given level of effort. There is uncertainty on the safety of certain states. Operational contexts, system behavior, and the notion of acceptable risk are constantly evolving. Therefore, safety envelopes need to be adapted continuously to these ever-changing conditions and requirements. Depending on the degree of autonomy, such AI systems need to self-maintain corresponding safety envelopes, possibly including online risk analysis.

### Component Safety Specifications

The behavior of machine learning components is specified by means of data. In supervised learning of ANNs, for example, a set of interpolation points is used for specifying the input-output behavior of the intended function. Inputs may be observations of the operational context, and outputs are corresponding context models.

The central challenge for data-driven requirements engineering is to represent the operational context by means of selected interpolation points as faithfully as possible for a given level of effort. This can be accomplished by sampling input scenarios from the (assumed) distribution of the operational context or by discretizing the operational context according to  $n$  features into  $2^n$  cells and sampling inputs from these cells. Both approaches are prohibitively expensive for many interesting operational contexts. A series of polynomial-time approximations, for example, have been developed to make feature-based discretization feasible in practical applications (Cheng, Huang, Nührenberg, & Ruess, 2018), and clustering and unsupervised learning techniques are used for identifying a finite number of representative classes of scenarios (Hauer, Gerostathopoulos, Schmidt, & Pretschner, 2020). It may also be interesting to construct sets of interpolation points that, when used for training a perception ANN, are sufficient for establishing invariance of the AI system with respect to a given safety envelope.

Given a set of, hopefully, representative interpolation points and an initial neural network architecture, an ANN is constructed by heuristically searching, usually based on hill-climbing,

---

<sup>23</sup> Cautious behavior might be realized by means of *minimizing surprises*, which may be realized by minimizing *free energy* or maximizing *predictive information*.

for a configuration to minimize the error between actual and specified outputs. This kind of heuristic search might get stuck in local minima, thereby leading to suboptimal solutions, or it might not terminate at all. Moreover, the resulting ANN might be *incorrect* in that its input-output behavior does not coincide with the specifying interpolation points, and the ANN might not be *resilient* in that slight variations of inputs lead to completely different output behavior, since many ANNs have a tendency of “overfitting” without further precautions in training. Consequently, the output of ANNs can often be altered by adding relatively small perturbations to the input vector (Su, Vargas, & Sakurai, 2019).

These kinds of uncertainties motivate the need for requirements of ANNs beyond data, such as resilience. For a fixed input, say  $x$ , and a metric  $d$  on the input space, an ANN is locally  $\varepsilon$ -resilient if  $\text{ANN}(x')$  is equal to – alternatively: similar to – the output  $\text{ANN}(x)$  for all small perturbations  $x'$  with  $d(x, x') < \varepsilon$ ; if the ANN is locally  $\varepsilon$ -resilient for all possible inputs, then it is also globally  $\varepsilon$ -resilient (Cheng, Nührenberg, & Rueß, Maximum resilience of artificial neural networks, 2017) (Seshia, et al., Formal Specification for Deep Neural Networks, 2018). The inherent uncertainty on the input-output behavior of ANNs is considerably reduced by establishing strong resilience properties.

Additional desired behavior of perception components usually come with their intended functionality. For example, an object classifier may be expected to correctly classify certain affine or homeomorphic images of training inputs, such as stretching, squeezing, rotational, and translational images. Sequences of context models for modelling traffic flow, for example, are also expected to obey fundamental laws of physics.

The challenge is to identify and maintain desired properties and potential defects of ANN-based perception components, which lead to undesired behavior. Moreover, the contribution of those properties and defects on the overall system safety need to be understood much better. This kind of knowledge should enable the development engineer, for example, to compute precise bounds on the required resilience of the perception ANN for arguing overall system safety.

### Deriving Component Safety Specifications

Given a safety specification, say  $S$ , of an AI system as depicted in Figure 1, we derive corresponding safety constraints on the possible behavior of the ANN-based perception component. The control, consisting of the deliberation and the execution units, needs to ensure that the output (the changed environment) is safe, that is, in  $S$ . In an engineered system we can compute the weakest precondition, say,  $wp(\text{controller})(S)$ , which now serves as the post-condition for the perception unit. Assuming that the input  $x$  to the perception unit is in  $S$ , that is, this state is safe, we get a pre/post-condition specification

$$(\forall x \in S) \text{perception}(x) \in \text{wp}(\text{controller})(S)$$

of the perception unit which is sufficient to establish safety of the overall AI system loop.<sup>24</sup> Adequate domain abstractions and corresponding abstract interpretation techniques are needed to make this approach feasible.

Indeed, researchers have taken first steps in this direction and identified special cases of pre/post-condition pairs for neural networks (Dutta, Jha, Sanakaranarayanan, & Tiwari, 2017) (Dvijotham, Stanforth, Gowal, Mann, & Kohli, 2018). Logical specifications  $\theta$  may also be incorporated into the training purpose of an ANN by constructing, for example, a corresponding differentiable loss function  $L(\theta)$ , such that  $x$  (logically) satisfies  $\theta$  whenever  $L(\theta)(x) = 0$ , or by incorporating constraints in a way that they will be satisfied by the model even on unseen data (Goyal, Dumancic, & Blockeel, 2021). More generally, in case of mutual dependencies between the perception unit and the controller for realizing active perception or in case of learning-enabled controllers, sufficiently strong preconditions for these two components can be synthesized based on, for example, a combination of traditional assume-guarantee reasoning and machine learning (Giannakopolou, Păsăreanu, & Barringer, 2002) (Păsăreanu, Gopinath, & Yu, 2019).

Instead of using sets of states as properties and state transformers between these properties, one also has the possibility of building uncertainty directly into the computational model of the AI system. In these cases, the behavior of AI systems may, at least partially and when necessary, be based on probabilistic sets, where states belong to a set with a certain probability only, and probabilistic transformers between probabilistic sets. The classical notions of weakest precondition and strongest postcondition generalize to probabilistic set transformers.

Whenever there is only a small finite number of interactions between the perception and the control unit, as is expected in many real-time systems, the weakest precondition approach above is applied to the unrolled system. These kinds of pre/postcondition specifications for the perception unit are the basis for largely decoupling the development of perception from the control unit. For example, as long as the controller adapts in time such that  $\text{wp}(\text{controller}')(\mathcal{S}) \subseteq \text{wp}(\text{controller})(\mathcal{S})$ , where  $\text{controller}'$  is the updated controller, then component-wise safety analyses still compose to a system-level safety argument; otherwise the challenge is to identify corresponding minimal sets of changes for the perception unit and its analysis. The perception specification can also be used either as additional input for the training of the perception ANN or as the basis for verifying such a component; for example, for systematically deriving test cases.

---

<sup>24</sup> Notice that the precondition  $x \in S$  is in the language of environment inputs, whereas the postcondition is in the language of the context models.

These initial ideas for systematically deriving component safety, particularly for learning-enabled components from overall systems safety requirements obviously need to be further developed and stress-tested on challenging real-world AI systems.

### Component Safety Verification

Furthermore, one may compute the weakest precondition of the perception ANN. For example, computing weakest preconditions of *ReLU* networks with their rather simple node activation functions is, in principle, straightforward (Sotoudeh & Thakur, 2019). Now, given a safety envelope  $S$ , the safety verification problem for an AI system (perception; control) may be stated as

$$wp(\textit{perception})(wp(\textit{controller})(S)) \subseteq S$$

This fundamental safety invariant immediately reduces to the local constraint for the perception unit:

$$\textit{perception}(S) \subseteq wp(\textit{controller})(S)$$

These kinds of constraints are statically analyzed based on symbolic verification techniques (Gopinath, Converse, Pasareanu, & Taly, 2019), used for test case generation, or dynamically checked by means of runtime verification (see Section

Analysis).

Also, the perception component may now be trained with the additional knowledge that its precondition is  $S$  and the postcondition is  $wp(\textit{controller})(S)$ . Logical constraints can also be interpreted in a more general quantitative logic for obtaining a differentiable objective function as needed for hill-climbing based training. Such quantitative interpretation may, for instance, be based on probabilistic sets and probabilistic transformers for modeling.

If we manage to train a “correct” ANN then we obtain a safety-by-design method for constructing safe AI systems. Indeed, as mentioned above, an ANN may be trained to obey some given logical safety property by constructing a corresponding differentiable loss function for the satisfiability of this formula. Still, there remains uncertainty about the safe behavior and input-output uncertainty due to the incorrectness of underlying learning algorithms. A new generation of knowledge-enhanced machine learning (Sagel, et al., 2020) techniques is tackling such real-world challenges for machine learning algorithms.



### 3. Uncertainty

Learning in the sense of replacing specific observations by general models is an inductive process. Such models are never provably correct but only hypothetical and therefore uncertain, and the same holds true for the predictions produced by a model.

In addition to the uncertainty inherent in inductive inference, other sources of uncertainty exist, including incorrect model assumptions and noisy or imprecise data. Correspondingly one usually distinguishes between *aleatoric* and *epistemic* sources of uncertainty (Dietterich, 2017) (Hüllermeier & Waegeman, 2021). Whereas aleatoric<sup>25</sup> uncertainty refers to the variability in the outcome of an experiment which is due to inherently random effects, epistemic<sup>26</sup> uncertainty refers to uncertainty caused by a lack of knowledge. In other words, epistemic uncertainty refers to the ignorance of an actor, and hence to its epistemic state, and can in principle therefore be reduced with additional information. There are various approaches towards robustness based on reducing uncertainty (Dietterich, 2017). Uncertainty reduction also plays a key role in active learning (Aggarwal, Kong, Gu, Han, & Philip, 2014), and in learning algorithms such as decision tree induction (Mitchell, 1980).

Indeed, there is a multitude of sources for uncertainty in the design of safe AI systems (Weyns, Bencomo, Calinescu, & et.al.). There is, among others, uncertainty about the operational context, there is uncertainty about hazards and risks, there is uncertainty about the correctness and generalizability of learning-enabled components, there is uncertainty about safety envelopes, there is uncertainty due to noise in sensing, there is controller uncertainty due to nondeterminism and/or probabilistic control algorithms, there is uncertainty on the internal models of the controller, and, last but not least, there is also uncertainty about the actions of human operators and their possible interaction with the AI-based control system.

Rigorous approaches for safe AI need to manage the multitude and heterogeneity of sources of uncertainty. We are therefore proposing an engineering approach based on the principle of uncertainty reduction, thereby increasing predictability (up to tolerable quantities) of the AI system. Crucial steps are:

- Identification of all<sup>27</sup> relevant sources of uncertainty.
- Quantification and estimation of uncertainty,<sup>28</sup> including certainty thereof.
- Forward and inverse propagation of uncertainty along chains<sup>29</sup> of computation.
- Modular composition of uncertainties along architectural decomposition<sup>30</sup> of the AI system.

---

<sup>25</sup> Aka statistical, experimental, or “known unknown”

<sup>26</sup> Aka systematic, structural, or “unknown unknown”

<sup>27</sup> In a defeasible manner

<sup>28</sup> Uncertainty quantification is the science of quantitative characterization and reduction of uncertainties in both computational and real world applications. Among others, it tries to determine how likely certain outcomes are if some aspects of the system are not exactly known.

<sup>29</sup> Including recursive chains.

<sup>30</sup> Both horizontal and vertical.

- Design operators for mitigating overall system uncertainty below a certain level as determined by a risk and safety analysis;<sup>31</sup> including:
  - A combination of offline and online accumulation of relevant knowledge for managing epistemic sources of uncertainty;
  - Incremental change of uncertainty reasoning due to self-learning or even self-modification capabilities of an AI system.

Clearly, these tasks for managing the multitude of heterogeneous sources for uncertainty of AI systems are fundamental in any rigorous and transparent engineering process. We currently do not have, however, a comprehensive set of methods and tools for supporting application engineers on managing uncertainties.

### Uncertainty about the environment

The operational environment of AI systems can be rather complex,<sup>32</sup> with considerable uncertainty even about how many and which objects and agents, both human and robotic, are in the environment, let alone about their intentions, behaviors, and strategies (Seshia, Sadigh, & Sastry, Towards Verified Artificial Intelligence, 2016). An AI system therefore must act without relying on a correct and complete model of the operating environment. The models at hand usually do not faithfully reflect the real-world operational context,<sup>33</sup> and it is simply not possible, and possibly not even desirable, to model everything. For dealing with modelling errors, AI systems may make distributional assumptions on the operational environment. It can be difficult, however, to exactly ascertain the underlying distribution.

As an alternative to explicitly modeling the operational environment it is common to specify this environment by means of a set of scenarios, which are supposed to be sampled with respect to the underlying distribution of the environment. These scenarios are analyzed and labeled with their respective interpretation of the context model in order to obtain training data for an ANN-based perception unit. It is a major challenge to select “good” scenarios. These scenarios are supposed to significantly reduce the difference between the, assumed, underlying distribution of the operating environment and the distribution of the selected training set. Collecting scenarios by driving around for, say, five hours on a stretch of highway in Alaska does not contribute as well to the approximation of real-world driving as, say, collecting driving scenarios at the Gate of India. Another concern is about evolving operating scenarios, and how to correspondingly adapt the set of specifying scenarios.

The challenge is to quantify and measure uncertainty between the operating environment and its specifying set of scenarios, identify “good” scenarios for reducing uncertainty to tolerable

---

<sup>31</sup> For example, less than one hazardous behavior for 10<sup>9</sup> operational time

<sup>32</sup> Operational Design Domains may be specified following standards such as PAS 1883 (<https://www.bsigroup.com/en-GB/CAV/pas-1883>)

<sup>33</sup> Again, the old slogan applies: all models are wrong, but some might be useful.

levels, provide sufficient conditions on the uncertainty of scenario sets for overall system safety (up to quantifiable tolerances as identified through safety risk assessment), adapt specifying scenario set to evolving operating environment.

### Behavioral Uncertainty of Learning-Enabled Components

We restrict our considerations on learning-enabled components to the widely popular class of ANNs. Such an ANN is a deterministic function. Due to non-linear activation functions, however, there is considerable uncertainty about its input-output behavior: training instances may or may not be represented correctly by the ANN, and it is usually unclear how, and how much, the input-output behavior of an ANN generalizes from training instances. The success of one-pixel attacks serves as a reminder on the limited generalizability and resilience of some machine-learned models.

Establishing resilience (Cheng, Nührenberg, & Rueß, Maximum resilience of artificial neural networks, 2017) or invariance properties - for example, invariance with respect to certain affine or homeomorphic transformations - of an ANN is an important means for reducing uncertainty on the input-output behavior. Some uncertainty about outcomes, however, remain. A systematic framework for analyzing different sources of uncertainty for ANNs is described in (Czarnecki & Salay, 2018).

*Measuring behavioral uncertainty.* Entropy may be used for quantifying uncertainty of a neural network. Indeed, under some mild assumptions on uncertainty, entropy is the only possible definition of uncertainty (Robinson, 2008), at least in its aleatoric interpretation. There are a multitude of indicators of behavioral uncertainty. (Cheng, Nührenberg, & Yasuoka, Runtime monitoring neuron activation patterns, 2019), for example, proposes to use the distance between neuron activations observed during training and the activation pattern for the current input as an estimation for the uncertainty of the input-output behavior.

*Training-based estimation of behavioral uncertainty.* Ensembles of neural networks, for example, estimate predictive uncertainty by training a certain number of NNs from different initializations and sometimes on differing versions of the dataset. The variance of the ensemble's predictions is interpreted as its epistemic uncertainty. Instances of ensemble learning techniques such as Bayesian neural networks (BNN) (Jospin, Buntine, Boussaid, Laga, & Bennamoun, 2020) measure both epistemic uncertainty  $P(\theta | D)$ , on model parameters  $\theta$  and the aleatoric uncertainty  $P(Y|X, \theta)$ . In fact, the predicted uncertainty of Bayesian neural networks (BNN) is often more consistent with observed errors, compared to classical neural networks. Out-of-training distribution points of a BNN leads to high epistemic uncertainty. The uncertainty  $P(\theta | D)$  can be reduced with more data. BNNs are also an interesting approach for active learning, as one can interpret the model predictions and see if, for a given input,

different probable parametrizations lead to different predictions. In the latter case, labelling of such an input will effectively reduce the epistemic uncertainty.

### Propagation of Uncertainty: from Faults to Failures

What we really should care about is not freedom from faults but absence of failure (Rushby, The Indefeasibility Criterion for Assurance Cases, 2020). Particularly, if a machine learning unit fails to meet its safety specification then we call this component *faulty*, and if the system fails to act safely then there is a system *failure*. Using corresponding random variables *Faulty* and *Failure* we are interested in the probability that the system is safe, that is  $P(\text{not Failure})$ ; using Bayes' rule we obtain:

$$P(\text{Failure} | \text{Faulty}) * P(\text{Faulty}) = P(\text{Faulty} | \text{Failure}) * P(\text{Failure})$$

Provably worst-case distributions (Zhao, Littlewood, Povyakalo, Strigini, & Wright, 2017) are used for estimating the posterior probability  $P(\text{Failure} | \text{Faulty})$  of faulty behaviors leading to safety violations.<sup>34</sup> The probability  $P(\text{Faulty})$  that the perception unit is faulty is approximated, for instance, using training-based estimation of behavioral uncertainty (as described above) or, alternatively, from an assurance-based estimation of uncertainty (as described below). Now, assuming that all but the perception unit are *possibly perfect* and that the faulty perception unit is the only possible cause of failure, then  $P(\text{Faulty} | \text{Failure}) = 1$ . Consequently, we can estimate  $P(\text{not Failure}) = 1 - P(\text{Failure})$  by means of Bayesian inference.

This short exposition of propagation of component faults to system safety failures is intended to demonstrate a possible style of Bayesian inference for establishing safety results. The underlying methodology however should also be applicable for more general mutually recursive system architectures.

### Assurance-based estimation of uncertainty

The goal of rigorous design is to gain sufficient confidence that failures, in our case safety violations, are very rare, up to tolerable quantities. Sufficient confidence cannot, however, be built up by looking at failures only.

Instead, assurance builds up a convincing case that failures are rare. One widely quoted definition for the corresponding notion of a safety case comes from (UK Ministry of Defence;

---

<sup>34</sup> *Failure* and *Faulty* are random variables, and the conditional probability  $P(\text{Failure} | \text{Faulty})$  measures the uncertainty that the system is unsafe (*Failure*) given that the perception unit violates its specification (*Faulty*).

2007): “A safety case is a structured argument, supported by a body of evidence that provides a compelling, comprehensible and valid case that a system is safe for a given application in a given operating environment.” An assurance case is simply the generalization of a safety case to properties other than safety.

An assurance case therefore is a comprehensive, defensible, and valid justification of the safety of a system for a given application in a defined operating context. It is based on a structured argument of safety considerations, across the system lifecycle, which can assist in convincing the various stakeholders that the system is acceptably safe.

The purpose is, broadly, to demonstrate that the safety-related risks associated with specific system concerns<sup>35</sup> have been identified, are well-understood, and have been appropriately mitigated, and that there are mechanisms in place to monitor the effectiveness of safety-related mitigations. In this sense, an assurance case is a structured argument for linking safety-related claims through a chain of arguments to a body of the appropriate evidence. One of the main benefits for structured arguments in assurance cases is to explicitly capture the causal dependencies between claims and the substantiating evidence.

Altogether, assurance cases are the basis for judging that a technical system is acceptable for widespread use. Assurance cases also determine the level of scrutiny needed for developing and operating systems which are acceptably safe. More specifically, assurance cases determine constraints on the design, implementation, verification, and training strategies, and they demonstrate the contributions of corresponding artifacts and activities to the overall system safety.

One may be confident in such an assurance based on “the quality of state of being certain that the assurance case is appropriately and effectively structured, and correct” (Grigорова & Maibaum, 2013). A necessary aspect of gaining confidence in the assurance case is dealing with uncertainty, which, as we have seen above, may have several sources. Uncertainty, often impossible to eliminate, nevertheless undermines confidence and must therefore be sufficiently bounded.

Recent extensions of assurance cases for reasoning about confidence and uncertainty (Duan, et al., 2014) are a good starting point for estimating and managing aleatoric and epistemic uncertainties for safe AI systems. In particular, probability theory has been proposed for quantifying confidence and uncertainty (Bloomfield, Littlewood, & Wright, Confidence: its role in dependability cases for risk assessment, 2007), epistemic uncertainty is quantified through the Dempster-Shafer theory of beliefs or Bayesian analysis (Swiler, Paez, & Mayes, 2009), the use of Bayesian Belief Networks (Littlewood & Wright, 2007) (Zhao, Zhang, Lu, & Zeng, 2012) (Dennney, Pai, & Habli, 2011), Josang’s opinion triangle (Duan, et al., 2014),

---

<sup>35</sup> Including safety and security, but also applies to all the other attributes of trustworthiness.

evidential reasoning (Nair, Walkinshaw, Kelly, & Vara, 2015), and weighted averages (Yamamoto, 2015).

There is, however, a slight problem with quantifying confidence in assurance case arguments, as proposed methods on Bayesian Belief Networks, Dempster-Shafer, and similar forms of evidential reasoning can deliver implausible results (Graydon & Holloway, 2017; Grigorova & Maibaum, 2013). Without strong evidence that the quantified confidence assessments are indeed trustworthy, there is no plausible justification for relying on any of these techniques in safety engineering. Alternatively, one may also look towards a value for the *probability of perfection* - based on extreme scrutiny of development, artifacts, and code - which is then related to confidence (Rushby, Formalism in safety cases. , 2010) (Rushby, Logic and epistemology in safety cases., 2013).

Qualitative approaches towards uncertainty, on the other hand, focus on the reasoning and rationale behind any confidence by building up an explicit confidence argument. For example, eliminative induction is increasing confidence in assurance cases by removing sources of doubt and using Baconian<sup>36</sup> probability to represent confidence (Goodenough, Weinstock, & Klein, 2012). Eliminative induction first identifies potential sources of doubt, so-called *defeaters*, and then work towards removing each source of doubt or proving that it is not relevant. The search for defeaters, and their own possible defeat, should be systematized and documented as essential parts of the case (Bloomfield & Rushby, Assurance 2.0: A manifesto, 2020). One systematic approach is through construction and dialectical consideration of counterclaims and countercases. Counterclaims are natural in *confirmation measures* as studied in Bayesian confirmation theory, and countercases are assurance cases for negated claims.

Assurance cases are successfully applied to a large number of safety-critical systems, and they have also proven to be flexible enough to be adopted to systems with learning-enabled components. An overall assurance framework for AI systems with an emphasis on quantitative aspects, e.g., breaking down system-level safety targets to component-level requirements and supporting claims stated in reliability metrics has recently been outlined (Zhao, et al., 2021). Requirements on assurance cases for autonomously acting vehicles with learning-enabled components are addressed, for example, by UL 4600.<sup>37</sup>

A mixture of requirements and data-centric metrics together with corresponding verification techniques, both static and dynamic (McDermid, Jia, & Habli, 2019), is needed to establish safety of AI systems with machine learning components. A successful element in a successful deployment of safety assurance for AI systems is a library of pre-validated argument steps (Bloomfield & Netkachova, Building blocks for assurance cases, 2014) (Hawkins, et al., 2021; Houben, et al., 2021) together with adequate operators for instantiating and composing

---

<sup>36</sup> <https://ntrs.nasa.gov/api/citations/20160013333/downloads/20160013333.pdf>

<sup>37</sup> <https://ul.org/UL4600>

specific system-specific assurance cases from these pre-validated structured arguments. We also hypothesize that, due to the multitude of sources of uncertainty, assurance arguments for increasingly autonomous AI systems, need to (1) stress rigor in the assessment of the evidence and reasoning employed, and (2) systematize and automate the search for defeaters, the construction of cases and counter cases, and the management and representation of dialectical examination. Increased rigor and automation in building and maintaining assurance cases should enable productive interaction with tools for logical and probabilistic reasoning and formal argumentation. Using frameworks such as STPA (Abdulkhaleq, Wagner, & Leveson, 2015) to better capture and examine a component's control actions in relation to the larger system level safety contexts may be beneficial. It is of particular interest how the influence of learning-enabled components is captured and reasoned within the AI control structure. And, finally, rigorous assurance cases open new possibilities of online self-adaptation of safety arguments for determining safe behavior when operating in uncertain contexts, since they can be adapted, quickly and efficiently, to ever-changing safety considerations of AI systems.

## 4. Analysis

A key issue for AI systems is rigorous safety analysis, which is based on a mixture of well-known verification and validation techniques with safety verification of learning-enabled components. Here we focus on novel aspects on analyzing AI systems with ANN-based perception units only.

But what do we actually need to verify about ANN components in order to support AI system safety? Our starting point here are the component requirements as obtained by breaking down application-specific systems safety requirements to verification and validation (V&V) requirements on the individual components of AI systems.

Due to mounting concerns of using ANNs for safety-related applications there has been a proliferation of new techniques with the intent of increasing their trustworthiness (Huang, A Survey of Safety and Trustworthiness of Deep Neural Networks: Verification, Testing, Adversarial Attack and Defence, and Interpretability , 2020) (Xiang, et al., 2018) (Schwalbe & Schels, 2020) (Houben, et al., 2021). It is well beyond the scope of these notes to survey this ever-growing number of methods and technologies for increasing the trustworthiness of ANN. Indeed, there is no lack of individual methods, but the safety relevance of many ANN analysis techniques (such as adversarial analysis) is questionable, particularly when the impact of the overall system within which the ANN is used is unclear (Dreossi, Jha, & Seshia, Semantic adversarial deep learning, 2018).

What is needed is a systematic evaluation of individual analysis techniques. A central challenge is to adequately measure and quantify how well and under which circumstances they improve confidence in the safe system behavior. A first step in this direction is provided in (Cârlan, Gallina, Kacianka, & Breu, 2017), as they develop a safety pattern for choosing and composing analysis techniques based on how they contribute to the identification and mitigation of systematic faults known to affect system safety. More generally, given an ANN and some desired properties, we therefore define the goal of ANN analysis to improve confidence, or, dually, reduce uncertainty, whether the desired properties hold, up to tolerable quantities, on the ANN.

### Testing

The goal of testing ANNs is to generate a set of test cases, that can demonstrate confidence in an ANN's performance, when passed, such that they can support an assurance case. Usually, the generation of test cases is guided by coverage metrics, both structural and non-structural (Chen, Yan, Wang, Kang, & Wu, 2014).



Traditional structural coverage criteria from software testing can usually not be applied directly to ANN. For example, neuron coverage is trivially fulfilled in ANN by a single test case. Moreover, MC/DC, when applied to ANNs, may lead to an exponential (in the number of neurons) number of branches to be investigated, and are therefore not practical as typical ANNs are comprised of millions of neurons. As usual in testing, the balance between the ability to find bugs and the computational cost of test case generation is essential for the effectiveness of a test method (Sun, et al., 2019).

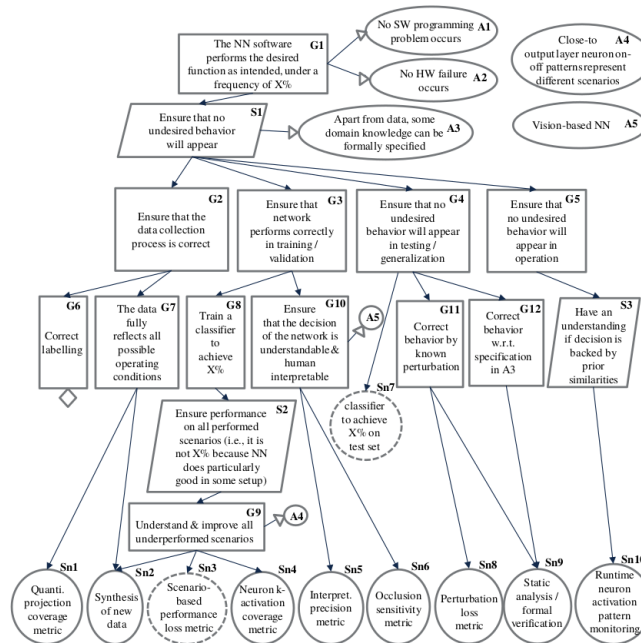

Figure 3. NNDK-based assurance case.

The generation of falsifying/adversarial test cases is generally using search heuristics based on gradient descent or evolutionary algorithms (Goodfellow, Shlens, & Szegedy, 2014; Goodloe & Pike, 2010) (Papernot, et al., 2016) (Carlini & Wagner, 2017). These approaches may be able to find falsifying examples efficiently, but they usually do not provide an explicit level of confidence about the nonexistence of adversarial examples when the algorithm fails to find one.

(Cheng, Huang, Nührenberg, & Ruess, 2018) develop ANN-specific non-structural test coverage criterion for the robustness, interpretability, completeness, and correctness of an ANN. A scenario coverage metric, for example, partitions the possible input space according to N attributes (e.g. snow, rainy, ...), and proposes, based on existing work on combinatorial testing, efficient k-projection (for  $k = 0, \dots, N-1$ ) coverage metrics as approximations of the exponential number of input partitions. In principle, a “complete” (with respect to the available input data) set of attributes may be obtained through unsupervised learning or clustering methods. These coverage metrics are implemented in the NNDK testing toolkit for ANNs (Sahu, et al., 2020).

In (Cheng, Huang, & Yasuoka, Quantitative projection coverage for testing ml-enabled autonomous systems, 2018) coverage is enforced to finite partitions of the input space, relying on predefined sets of application-specific scenario attributes. In a similar vein, the “boxing clever” technique focuses on the distribution of training data and divides the input domain into a series of representative boxes.

A number of traditional test case generation techniques such as fuzzing (Odena, Olsson, Andersen, & Goodfellow, 2018; Owhadi, Scovel, Sullivan, McKerns, & Ortiz, 2013; Papernot, et al., 2016) (Xie, et al., 2018), symbolic execution (Gopinath, Wang, Zhang, Pasareanu, & Khurshid, 2018), concolic testing (Sun, et al., 2018), mutation testing (Shen, Wan, & Chen, 2018), mutation testing, and metamorphic testing (Zhang, Zhang, Liu, & Khurshid, 2018) have been extended to support the verification of ANNs. Despite their effectiveness in discovering various defects of ANNs together with their data-centric requirement specifications, however, it is not exactly clear how testing-based approaches can be efficiently integrated into the construction of convincing safety argumentations for AI systems. A possible step in this direction, however, is the NNDK-based safety case in Figure 3, which makes the contribution and the rationale behind individual test metrics in establishing safety goals more explicit.

Altogether, testing methods seem to be effective at discovering defects of ANNs. It is unclear, however, how to measure the effectiveness of test coverage metrics in building up sufficient confidence – or dually, raising doubts – in a convincing assurance case. Also, most testing-based approaches assume a fixed ANN. However, ANNs are learning-enabled and trained continuously on new data/scenarios. The challenge is to come up with methodologies for efficiently - depending on the application context also in real-time - retesting safety requirements for continuously evolving ANNs. Such a retesting methodology could be based on adapting corresponding assurance cases.

Instead of validating individual learning-enabled components, the idea of scenario-based testing is to (1) automatically or manually identify a reasonably small set of relevant dynamic situations, or scenario types; (2) check if the set of scenario types is complete; and then (3) derive system-specific tests for each scenario type. This immediately raises the need for a test ending criterion based on the following question: did we test all scenario types? And did we sufficiently test each type with specific instances? The general approach to scenario-based testing is outlined in Figure 4. It is based on automated clustering of real driving data and completeness checks for the clusters thus obtained (Hauer, Schmidt, Holzmüller, & Pretschner, 2019).

---

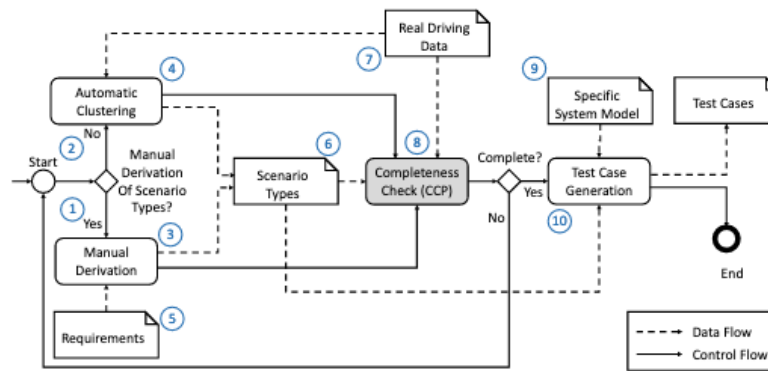

**Figure 4.** Scenario-Based Testing.<sup>38</sup>

### Symbolic Verification

Safety verification problems for ANNs can be reduced to constraint solving problems such as satisfiability in propositional logic (Cheng, Nührenberg, Huang, & Rues, 2018) (Narodytska, Kasiviswanathan, Ryzhyk, Sagiv, & Walsh, 2018), satisfiability modulo theories (Huang, Kwiatkowska, Wang, & Wu, 2017) (Pulina, 2010) (Katz, Barrett, Dill, Julian, & Kochendoerfer, 2017) (Tuncali, Ito, Kapinski, & Deshmukh, 2018), and mixed-integer linear programming (Cheng, Nührenberg, & Rueß, Maximum resilience of artificial neural networks, 2017). These approaches typically do not scale up to the size of real-world ANNs with millions of neurons. Approximation techniques are applied to improve efficiency, but usually at the expense of precision. Recent approaches based on global optimization have the potential of dealing with larger networks (Ruan, Huang, & Kwiatkowska, 2018). Compositional verification techniques for scaling up ANN safety verification are largely missing. For assume-guarantee style reasoning applied to the verification of an ANN-based automotive safety controller, however, see (Cheng, Huang, Brunner, & Hashemi, 2020).

Since symbolic safety verification technologies work on a model of the ANN they might certain defects due to implementation issues (for example, rational numbers vs. IEEE floating point implementations). It is also unclear how to efficiently apply these techniques to continuously changing ANNs.

### Runtime verification

In runtime verification a monitor observes the concrete execution of the system in question and checks for violations of stipulated properties. When the monitor detects a violation of a property, it notifies a command module which then isolates the cause of the violation and

<sup>38</sup> Source: <https://doi.org/10.1109/ITSC.2019.8917326>

attempts to recover from the violation. In this way, runtime verification is a central element of FDIR-based<sup>39</sup> fault-tolerant systems. For the multitude of sources for uncertainty in AI systems, stringent real-time requirements, and ever-changing learning-enabled components, runtime verification is an essential element for safety verification of AI systems.

System requirements of the form “the system must perform action  $a$  within  $n$  seconds of event  $e$ ” are common in runtime monitoring of autonomous systems (Kane, Chowdhury, Datta, & Koopman, 2015). These kinds of properties are expressible in suitable sub-logics of metric temporal logic such as GXW (Cheng, Hamza, & Rueß, Structural Synthesis for GXW Specifications, 2016) (Cheng, Lee, & Rueß, Autocode4: Structural controller synthesis, 2017; Dennney, Pai, & Habli, 2011) and timed extensions thereof (Xin & Rueß, 2021). These kinds of specifications are compiled into (timed) synchronous dataflows as the basis for efficient runtime monitors. A dynamic programming and rewriting-based algorithm for monitoring MTL formulas is described in (Thati & Roşu, 2005). Moreover, architectural design principles for monitoring distributed systems are needed to ensure that monitoring does not perturb the system (at least, not too much) (Goodloe & Pike, 2010). In particular, the tutorial (Bonakdarpour & Fischmeister, 2011) discusses challenges on instrumenting real-time systems so that timing constraints of the system are respected. A recent tutorial describes state-of-the-practice technology for generating runtime monitors that capture the safe operational environment of systems with AI/ML components (Torfah, Junges, Fremont, & Seshia).

Altogether, runtime verification is an essential and attractive technique of any verification strategy for safe AI. Unlike static verification techniques such as testing or symbolic verification, there is no need for adaptation to learning-based components such as ANNs. In this way, runtime monitoring is an enabling verification technology for continuous assurance, based on the MAPE-K<sup>40</sup> loop from autonomic computing. The main challenge in deploying runtime monitoring, as is the case for any other cyber-physical system, is to embed monitors in an efficient (for example, energy-efficient) way, without perturbing the behavior of the AI system too much.

Runtime monitoring may also be used for measuring uncertainties in input-output behavior of ANNs. For example, if an input is out-of-distribution of the training set, then one may conclude that the “correctness” of the corresponding ANN output may be doubtful. Such information about the uncertainty of a perception result may be useful input for planning in the deliberation stage. Uncertainty information about the perception unit is also used in Simplex architectures for switching to a safe(r) perception channel whenever the ANN output is doubtful. Clearly, the distance (in some given metric) of the input to the set of training input may serve as a measure of uncertainty of the input-output behavior of the ANN. Notice,

---

<sup>39</sup> Fault Detection, Isolation, and Recovery.

<sup>40</sup> Measure, Analyze, Plan, Execute; the K stands for Knowledge.

however, that such a measure returns uncertainty zero even for “incorrect” behavior of the ANN on training inputs. Alternatively, (Cheng, Nührenberg, & Yasuoka, Runtime monitoring neuron activation patterns, 2019) propose to monitor the neuronal activation pattern of some input, and to compare it with neuronal activation patterns as learned during the ANN training phase. Notice that this measure of certainty on the input-output behavior of an ANN is part of the assurance case for an ANN in Figure 3. In addition, applicable background knowledge and physical laws may also be used in monitoring the plausibility of the input-output behavior of an ANN.

In summary, due to the multitude of sources of uncertainty, the complexity of AI-based systems and the environments in which they operate, even if all the challenges for specification and verification are solved, it is likely that one will not be able to prove unconditional safe and correct operation. There will always be situations in which we do not have a provable guarantee of correctness. Therefore, techniques for achieving fault tolerance and error resilience at run time must play a crucial role. There is, however, not yet a systematic understanding of what can be achieved at design time, how the design process can contribute to safe and correct operation of the AI system at run time, and how the design-time and run-time techniques can interoperate effectively.

## 5. Safety-by-Design

Validation and verification activities are usually complemented with *safe-by-construction* design steps. We briefly describe some of the main challenges and initial approaches towards safe-by-design; namely property-driven synthesis of learning-enabled components, compositional construction of AI subsystems and systems, and safety architectures for AI systems. The goal in this respect is a fundamental set of building blocks together with composition and incremental change operators for safe-by-construction design and for continual assurance of large classes of AI systems.

### Property-driven synthesis of learning-enabled components

Instead of using *a posteriori* verification of desirable properties of ANNs by means of static or dynamic verification technologies as outlined above, it is a natural question to ask ourselves: can we design, from scratch, a machine learning component that provably satisfies (possible in a robust interpretation) given formal specifications? For example, given pre- and postconditions of an ANN, as obtained from breaking down system safety envelopes down to individual learning-enabled components, is it possible to train an ANN that satisfies the given safety specification. Given a property expressed in logic, for example, one constructs a corresponding differentiable loss function for property-driven training of the ANN. In this way, property-driven synthesis needs to, among other things, design an appropriate training set, set up the initial structure of the ANN, choose and adjust appropriate hyper-parameters for training. The selection of training sets and training then is guided by reducing an adequate measure of the uncertainty that the ANN indeed satisfies the given specification.

Progress is needed along all these fronts. Techniques of neuro-symbolic computation (Raedt, Manhaeve, & Dumancic, 2019) (Riegel & et.al., 2020) may be a good starting point, as they also try to integrate high-level reasoning with low-level perception in such a way that neuro-symbolic methods have the pure neural, logical, and probabilistic methods as special cases. A short history and perspectives for knowledge-augmented machine learning are described in (Sagel, et al., 2020).

### Compositional System Design

The triad of perception, deliberation, and execution as depicted in Figure 1 is only the simplest possible architecture of an AI system. Often, deliberation and execution units are mutually dependent for realizing a fine-grained control, perception may also be dependent on deliberation, say, in AI systems with active perception. Moreover, each stage of the AI systems triad is usually decomposed into any number of functional units including monitors and safe channels. For example, deliberation may include functionalities for modeling AI capabilities such as interpretation and prediction, model building, derivation of knowledge, goal management, or planning, and perception is decomposed into a pipeline of tasks for, say internal and external state estimation, sensor fusion, object recognition, object classification.

Such a real-world architecture for realizing an autonomous driving function can be found, for example, in (Aptiv, et al., 2019). This publication advocates the use of state-of-the-practice dependability and safety engineering methodologies as prescribed in current industrial safety standards,<sup>41</sup> for safing SAE L3 and L4 automated driving capabilities.

Traditional Simplex architectures (Sha, 2001) are used for addressing both performance and safety requirements of a number of automated and autonomous systems (Schiemann, et al., 2001) (Bak, Manamcheri, Mitra, & Caccamo, 2011) (Phan, et al., 2017) (Aswani, Bouffard, & Tomlin, 2012) by leveraging run-time assurance, where the results of design-time verification are used to build a system that monitors itself and its environment at run time. More precisely, a Simplex architecture comprises (1) a performant controller under nominal operating conditions, which is design to achieve high-performance, but it is not provably safe (2) a safe controller that can be pre-certified to be safe, and (3) a decision module which is pre-certified (or safe-by-design) to monitor the state of the controlled system and its operational environment to check whether desired system safety specifications can be violated. If so, the decision module switches control from the nominal to the safe monitor. Provably safe composition of Simplex architectures is developed in the context of *Soter* (Desai, Ghosh, Seshia, Shankar, & Tiwari, 2019), which also allows for switching to nominal control as to keep performance penalties to a minimum while retaining strong safety guarantees.

While compositional design operators have been developed for digital circuits and embedded systems, we do not yet have such comprehensive theories for AI systems. For example, if two ANNs are used for perception on two different types of sensors, say LiDAR and camera, and individually satisfy their specifications under certain assumptions, under what conditions can they be used together for decreasing perception uncertainty? More generally, how can we compositionally design safe and predictable perception pipelines? How can one design planning and deliberation components for overcoming the inherent limitations of their ANN-based perception component? How can one design execution components for minimizing

---

<sup>41</sup> Among others, ISO 26262 in the automotive industry, and DO 178C in aerospace.

## Safe AI

surprises in uncertain environments? And how can these components interact in a safe and quasi-predictable<sup>42</sup> manner?

---

<sup>42</sup> That is, predictable up to acceptable levels.



<b>Specification Challenge</b>	<ul style="list-style-type: none"> <li>• Provide means for constructing (and maintaining) safety envelopes, either deductively from safety analysis or inductively from safe nominal behavior</li> <li>• Provide means for minimizing uncertainties related to safety envelopes with a given level of effort</li> <li>• Provide means for deriving safety requirements for learning-enabled components, which are sufficient for establishing AI system safety</li> <li>• Provide means for reducing specification uncertainty by means of deriving data requirements for learning-enabled components</li> </ul>
<b>Uncertainty Challenge</b>	<ul style="list-style-type: none"> <li>• Identify all relevant sources of uncertainty for an AI system</li> <li>• Provide adequate means for measuring uncertainty</li> <li>• Calculate forward propagation of uncertainty, where the various sources of uncertainty are propagated through the model to predict overall uncertainty in the system response</li> <li>• Identify and solve relevant inverse<sup>43</sup> uncertainty quantification problems for safe AI (using, for example, a Bayesian approach)</li> <li>• Predict (up to tolerable quantities) the unsafe behavior of AI systems operating in uncertain environments</li> </ul>
<b>Assurance Challenge</b>	<ul style="list-style-type: none"> <li>• Provide adequate measures of uncertainty for assuring AI system safety</li> <li>• Construct and maintain evidence-based arguments for supporting the certainty and for rebutting the uncertainty of safety claims</li> <li>• Identify useful safety case patterns<sup>44</sup> for safe AI systems and identify corresponding operators for instantiating these patterns and for composing them</li> </ul>
<b>Design Challenge</b>	<ul style="list-style-type: none"> <li>• Develop safety case patterns for different architectural designs of AI systems<sup>45</sup></li> <li>• Compositionally construct safe and quasi-predictable AI systems together with their safety cases</li> </ul>
<b>Analysis Challenge</b>	<ul style="list-style-type: none"> <li>• Provide adequate means for measuring and for reducing uncertainty on the input-output behavior of learning-enabled components</li> <li>• Define and measure the respective contribution of static and dynamic analysis techniques for learning-enabled systems, towards reducing safety-related uncertainty to tolerable levels</li> </ul>
<b>Maintenance Challenge</b>	<ul style="list-style-type: none"> <li>• Identify incremental change operators for maintaining uncertainty and safety assurance of self-learning AI systems</li> <li>• Safely adapt and optimize the situational behavior of an AI system (together with its safety cases based on the principle of minimizing uncertainty)</li> </ul>

**Table 1.** Safe AI Engineering Challenges.

<sup>43</sup> That is, calculating from a set of observations the causal factors that produced them

<sup>44</sup> Cmp. AMLAS

<sup>45</sup> In analogy to, say, Mills separation kernel protection profile.

## 6. Conclusions

We have been arguing that traditional safety engineering is not suitable for developing and operating safe AI systems for real-world control applications. Based on this insight we outlined a rigorous safety engineering methodology for AI, which is centered around managing and assuring uncertainty to acceptable levels (Chechik, Salay, Viger, Kokali, & Rahimi, 2019; Carlini & Wagner, 2017), as the basis for predicable (up to acceptable tolerances) and safe AI systems.

The proposed rigorous design methodology for safe AI is based on the central notion of a safety case for managing uncertainties. Our proposals are compatible with the emergent standard UL4600<sup>46</sup> on required properties for safety cases. In some sense, the depicted design methodology may also be viewed as an uncertainty-based amalgam of the paradigms of data-with model-driven design.

The main contribution lies in the identification of core challenges and possible research directions on the specification, design, analysis, assurance, and maintenance of safe AI (for a summary, see *Table 1*). This list, however, is incomplete, as we have omitted, for instance, all-important challenges due to interactive control between human operators and the machine-based control.

The identified challenges for safe AI as listed in *Table 1* do not seem to be insurmountable hard to overcome. The overarching challenge rather lies in the integration of individual methods into a coherent and comprehensive engineering framework for systematically managing and reducing uncertainty to tolerable quantities, and to demonstrate its relative merits on real-world AI systems.

We have been working towards AI safety engineering, among others, with Fasten ( (Cârlan & Ratiu, FASTEN.Safe: A model-driven engineering tool to experiment with checkable assurance cases, International Conference on Computer Safety, Reliability, and Security; Cheng, Huang, Nührenberg, & Ruess, 2018) for checkable safety cases, evidential transactions in Evidentia/CyberGSN for continual assurance and compliance (Beyene & Carlan, 2021), and the neural network dependability kit (Sahu, et al., 2020) for analyzing artificial neural networks, and risk-based safety envelopes for autonomous vehicles under perception uncertainty (Bernhard, Hart, Sahu, Schöller, & Cancimance, 2021). We are also currently working on concrete safe AI use cases for integrating these individual engineering nuggets, and for elaborating a generally useful approach for safe AI engineering. We hypothesize that uncertainty quantification also plays an increasingly prominent role in analyzing and certifying

---

<sup>46</sup> <https://edge-case-research.com/ul4600/>

complex software systems, since traditional notions of system-level correctness are becoming less applicable for heterogeneous and ever-evolving software landscapes.

There are related ideas on *uncertainty quantification* in engineering (Owhadi, Scovel, Sullivan, McKerns, & Ortiz, 2013) for certifying that, with high probability, a real-valued response function of a given physical system does not exceed a given safety threshold. Uncertainty quantification also plays a pivotal role in minimizing uncertainties for ANNs (Abdar, et al., 2021). We expect these kinds of techniques to provide a mathematical underpinning of a rigorous design calculus for safe AI.

The ultimate goal in this respect is a rigorous engineering framework based on pre-certified parameterized components, corresponding assurance arguments, and system composition operators (for example, for watchdogs, monitors, and redundant channels) from which complete systems and corresponding assurance cases are constructed in a property-guided, traceable, and optimized manner.

In addition, onboard management of uncertainty is used for the design of safe exploration strategies of unknown territory based on the principle of managing uncertainty and for minimizing surprises. This kind of safe exploration of an AI system might even be complemented with online risk and safety assessment together with corresponding online updates of safety cases and uncertainty quantifications thereof.

## References

- Abdar, Pourpanah, Hussain, Rezazadegan, Liu, Ghavamzadeh, & Nahavandi. (2021). A review of uncertainty quantification in deep learning: Techniques, Applications and Challenges. *Information Fusion*.
- Abdulkhaleq, Wagner, & Leveson. (2015). A comprehensive safety engineering approach for software-intensive systems based on STPA. *Procedia Engineering*.
- Aggarwal, Kong, Gu, Han, & Philip. (2014). Active learning: A survey. *Data Classification: Algorithms and Applications*. CRC Press.
- Alves, Bhatt, Hall, Driscoll, Murugesan, & Rushby. (2018). Considerations in assuring safety of increasingly autonomous systems. NASA.
- Amini, Azari, Bhaskaran, Beauchamp, Castillo-Rogez, Castano, & Wyatt. (2020). Advancing the scientific frontier with increasingly autonomous systems. *arXiv:2009.07363*.
- Amodei, Olah, Steinhardt, Christiano, Schulman, & Mané. (2016). Concrete problems in AI safety. *arXiv:1606.06565*.
- Aptiv, Audi, Baidu, BMW, Continental, Daimler, . . . Volkswagen. (2019). Safety first for automated driving. *Whitepaper*.  
<https://www.daimler.com/documents/innovation/other/safety-first-for-automated-driving.pdf>.
- Aswani, Bouffard, & Tomlin. (2012). Extensions of learning-based model predictive control for real-time application to a quadrotor helicopter. *American Control Conference (ACC)*. IEEE.
- Bak, Manamcheri, Mitra, & Caccamo. (2011). Sandboxing controllers for cyber-physical systems,. *IEEE/ACM Second International Conference on Cyber-Physical Systems*. IEEE.
- Balta, Sellami, Kuhn, Schöpp, Buchinger, & Baracaldo. (2021). Accountable Federated Machine Learning in Government: Engineering and Management Insights. *International Conference on Electronic Participation*. Springer.
- Bernhard, Hart, Sahu, Schöller, & Cancimance. (2021). Risk-Based Safety Envelopes for Autonomous Vehicles Under Perception Uncertainty. *arXiv:2107.09918*.
- Beyene, & Carlan. (2021). CyberGSN: A semi-formal language for specifying safety. *51st Annual IEEE/IFIP International Conference on Dependable Systems and Networks Workshops (DSN-W)* . IEEE.
- Bhattacharyya, Cofer, Musliner, Mueller, & Engstrom. (2015). Certification considerations for adaptive systems. *International Conference on Unmanned Aircraft Systems (ICUAS)*. IEEE.
- Björkman. (1994). Internal cue theory: Calibration and resolution of confidence in general knowledge. *Organizational Behavior and Human Decision Processes*.
- Blanquart, Fleury, Hernek, Honvault, Ingrand, Poncet, . . . Thévenod. (2003). Software Product Assurance for Autonomy On-Board Spacecraft. *DASIA-2003 Data Systems in Aerospace*. ESA SP-532.
- Bloomfield, & Netkachova. (2014). Building blocks for assurance cases. *IEEE International Symposium on Software Reliability Engineering Workshops*. IEEE.
- Bloomfield, & Rushby. (2020). Assurance 2.0: A manifesto. *arXiv:2004.10474*.
- Bloomfield, Littlewood, & Wright. (2007). Confidence: its role independability cases for risk assessment. . *Dependable Systems and Networks*.

- Bojarski, Testa, d., Dworakowski, Firner, Flepp, Goyal, & Zieba. (2016). End-to-end learning for self-driving cars. arXiv:1604.07316.
- Bonakdarpour, & Fischmeister. (2011). Runtime-monitoring of time-sensitive systems. *n International Conference on Runtime Verification*. Springer.
- Cârlan, & Ratiu. ( International Conference on Computer Safety, Reliability, and Security). FASTEN.Safe: A model-driven engineering tool to experiment with checkable assurance cases. 2020. Springer.
- Cârlan, Gallina, Kacianka, & Breu. (2017). Arguing on software-level verification techniques appropriateness. *International Conference on Computer Safety, Reliability, and Security*, pp. 39-54. Springer.
- Carlini, & Wagner. (2017). Towards evaluating the robustness of neural networks. *IEEE Symposium on Security&Privacy*. IEEE.
- Chechik, Salay, Viger, Kokali, & Rahimi. (2019). Software Assurance in an Uncertain World. *International Conference on Fundamental Approaches to Software Engineering*. Springer.
- Chen, Yan, Wang, Kang, & Wu. (2014). Deep neural network test coverage: How far are we? arXiv:2010.04946v2.
- Cheng, Hamza, & Rueß. (2016). Structural Synthesis for GXW Specifications. *International Conference on Computer Aided Verification* . Springer, LNCS.
- Cheng, Huang, & Yasuoka. (2018). Quantitative projection coverage for testing ml-enabled autonomous systems. *International Symposium on Automated Technology for Verification and Analysis*. Springer.
- Cheng, Huang, Brunner, & Hashemi. (2020). Towards safety verification of direct perception neural networks. *Design, Automation & Test in Europe Conference & Exhibition*. IEEE.
- Cheng, Huang, Nührenberg, & Ruess. (2018). Towards dependability metrics for neural networks. *16th ACM/IEEE International Conference on Formal Methods and Models for System Design (MEMOCODE)* .
- Cheng, Lee, & Rueß. (2017). Autocode4: Structural controller synthesis. *International Conference on Tools and Algorithms for the Construction and Analysis of Systems*. Springer, LNCS.
- Cheng, Nührenberg, & Rueß. (2017). Maximum resilience of artificial neural networks. *International Symposium on Automated Technology for Verification and Analysis*. Springer.
- Cheng, Nührenberg, & Yasuoka. (2019). Runtime monitoring neuron activation patterns. *Design, Automation & Test in Europe Conference & Exhibition* . IEEE.
- Cheng, Nührenberg, & Yasuoka. (2019). Runtime monitoring neuron activation patterns.
- Cheng, Nührenberg, Huang, & Ruess. (2018). Verification of binarized neural networks via inter-neuron factoring. *Working Conference on Verified Software: Theories, Tools, and Experiments*. Springer.
- Czarnecki, & Salay. (2018). Towards a framework for managing perception uncertainty for safe automated driving. *International Conference on Computer Safety, Reliability, and Security*. Springer.
- Dennney, Pai, & Habli. (2011). Towards measurement of uncertainty in safety cases. *International Symposium on Empirical Software Engineering and Measurement* . IEEE.
- Desai, Ghosh, Seshia, Shankar, & Tiwari. (2019). SOTER: a runtime assurance framework for programming safe robotics systems. *49th Annual IEEE/IFIP International Conference on Dependable Systems and Networks*. IEEE.
- Dietterich, T. (2017). Steps Toward Robust Artificial Intelligence. *AI Magazine*, 38(3), pp. 3-24.

- Dreossi, Ghosh, Sangiovanni-Vincentelli, & Seshia. (2019). A formalization of robustness for deep neural networks. *arXiv:1903.10033*.
- Dreossi, Jha, & Seshia. (2018). Semantic adversarial deep learning. *International Conference on Computer Aided Verification (CAV)*. Springer.
- Duan, Rayadurgam, Heimdahl, Ayoub, Sokolsky, & Lee. (2014). Reasoning About confidence and uncertainty in assurance cases: A survey. *Software Engineering in Health Care*, pp 64-80.
- Dutta, Jha, Sanakaranarayanan, & Tiwari. (2017). Output range analysis for deep neural networks. *arXiv:1709.09130*.
- Dvijotham, Stanforth, Gowal, Mann, & Kohli. (2018). A dual approach to scalable verification of deep networks. *UAI (Vol. 1, No. 2, p. 3)*. *arXiv:1803.06567*.
- Geisberger, & Broy. (2015). Living in a networked world: Integrated research agenda Cyber-Physical Systems (agendaCPS). Herbert Utz Verlag.
- Giannakopolou, Păsăreanu, & Barringer. (2002). Assumption generation for software component verification. *17th IEEE International Conference on Automated Software Engineering*. IEEE.
- Goodenough, Weinstock, & Klein. (2012). Toward a theory of assurance case confidence. *Technical Report CMU/SEI-2012-TR-002, ESC-TR-2012-002*. Carnegie-Mellon University.
- Goodfellow, Shlens, & Szegedy. (2014). Explaining and harnessing adversarial examples. *arXiv:1412.6572*.
- Goodloe, & Pike. (2010). Monitoring distributed real-time systems: a survey and future directions. National Aeronautics and Space Administration, Langley Research Center.
- Gopinath, Converse, Pasareanu, & Taly. (2019). Property Inference for Deep Neural Networks. *34th IEEE/ACM International Conference on Automated Software Engineering (ASE)*, pp. 797-809. IEEE.
- Gopinath, Wang, Zhang, Pasareanu, & Khurshid. (2018). Symbolic execution for deep neural networks. *arXiv:1807.10439*.
- Goyal, Dumancic, & Blockeel. (2021). SaDe: Learning Models that Provably Satisfy Domain Constraints. *arXiv:2112.00552*.
- Graydon, & Holloway. (2017). An investigation of proposed techniques for quantifying confidence in assurance arguments. *Safety Science* 92, pp. 53-65.
- Grigoroava, & Maibaum. (2013). Taking a page from the law books: Considering evidence weight in evaluating assurance case confidence. *IEEE International Symposium on Software Reliability Engineering Workshops (ISSREW)*, pp. 387-390. IEEE.
- Hüllermeier, & Waegeman. (2021). Aleatoric and epistemic uncertainty in machine learning: an introduction to concepts and methods. *Machine Learning*, 110(3), pp. 457-506.
- Hammerschmidt, C. (2019, May 28). ISO 26262 is not perfectly designed for Artificial Intelligence. *eeNews Automotive*. <https://www.eenewsautomotive.com/news/iso-26262-not-perfectly-designed-artificial-intelligence>.
- Hauer, Gerostathopoulos, Schmidt, & Pretschner. (2020). Clustering traffic scenarios using mental models as little as possible. *IEEE Intelligent Vehicles Symposium (IV)*, pp. 1007-1012. IEEE.
- Hauer, Schmidt, Holzmüller, & Pretschner. (2019). Did we test all scenarios for automated and autonomous driving systems? *IEEE Intelligent Transportation Systems Conference (ITSC)*, pp. 2950-2955. IEEE.
- Hawkins, Paterson, Picardi, Jia, Calinescu, & Habli. (2021). Guidance on the assurance of machine learning in autonomous systems (AMLAS). *arXiv:2102.01564*.
- Holloway. (2018). Understanding the Overarching Properties: First Steps. NASA Langley Research Center.

- Houben, Abrecht, Akila, Bär, Brockherde, Feifel, & Woehrle. (2021). Inspect, understand, overcome: A survey of practical methods for AI safety. *arXiv:2104.14235*.
- Huang. (2020, May). A Survey of Safety and Trustworthiness of Deep Neural Networks: Verification, Testing, Adversarial Attack and Defence, and Interpretability . *arXiv:1812.08342v5*.
- Huang, Kwiatkowska, Wang, & Wu. (2017). Safety verification of deep neural networks. *International conference on computer aided verification*, pp. 3-29. Springer.
- Jospin, Buntine, Boussaid, Laga, & Bennamoun. (2020). Hands-on bayesian neural networks - a tutorial for deep learning users. *arXiv:2007.06823*.
- Kane, Chowdhury, Datta, & Koopman. (2015). A case study on runtime monitoring of an autonomous research vehicle (ARV) system. *Runtime Verification*, pp. 102-117. Springer, LNCS.
- Katz, Barrett, Dill, Julian, & Kochendoerfer. (2017). Reluplex: An efficient SMT solver for verifying deep neural networks. *International Conference on Computer Aided Verification (CAV)*, pp. 97-117. Springer.
- Koopman, Osyk, & Weast. (2019). Autonomous vehicles meet the physical world: Rss, variability, uncertainty, and proving safety . *International Conference on Computer Safety, Reliability, and Security (SAFECOMP)*, pp. 245-253. Springer.
- LeCun, Bottou, Bengio, & Haffner. (1998). Gradient-based learning applied to document recognition. *Proceedings of the IEEE*, 86(11), pp. 2278-2324. IEEE.
- Littlewood, & Wright. (2007). The use of multilegged arguments to increase confidence in safety claims for software-based systems: A study based on a BBN analysis of an idealized example. *IEEE Transactions on Software Engineering*, 33(5), 347-365. IEEE.
- McDermid, Jia, & Habli. (2019). Towards a framework for safety assurance of autonomous systems. *Artificial Intelligence Safety, CEUR Workshop Proceedings*.
- Mitchell. (1980). The need for biases in learning generalizations. *Tech. Rep. TR CBM-TR-117, Rutgers University*.
- Nair, Walkinshaw, Kelly, & Vara, d. l. (2015). An evidential reasoning approach for assessing confidence in safety evidence. *ISSRE*.
- Narodytska, Kasiviswanathan, Ryzhyk, Sagiv, & Walsh. (2018). Verifying properties of binarized deep neural networks. *Proceedings of the AAAI Conference on Artificial Intelligence (Vol. 32, No. 1)*.
- NASA Engineering and Safety Center. (2011, Jan 18). National highway traffic safety administration Toyota unintended acceleration investigation. . *Technical Assessment Reportz*.
- Nguyen, Destercke, & Hüllermeier. (2019). Epistemic uncertainty sampling. *22nd International Conference on Discovery Science*, pp. 72-86. Springer.
- Odena, Olsson, Andersen, & Goodfellow. (2018). TensorFuzz: Debugging neural networks with coverage-guided fuzzing. *International Conference on Machine Learning (pp. 4901-4911)*. PMLR.
- Owhadi, Scovel, Sullivan, McKerns, & Ortiz. (2013). Optimal uncertainty quantification. *Siam Review*, 55(2), 271-345.
- Păsăreanu, Gopinath, & Yu. (2019). Compositional verification for autonomous systems with deep learning components. . *Safe, Autonomous and Intelligent Vehicles*, pp. 187-197. Springer.
- Papernot, McDaniel, Jha, Fredrikson, Celik, & Swami. (2016). The limitations of deep learning in adversarial settings. *Papernot, N., McDaniel, P., Jha, S., Fredrikson, M., Celik, Z. B., & Swami, A. (2016, March). The limitations of deep learning in adversarial settings. In 2016 IEEE European symposium on security and privacy (EuroS&P)*, pp. 372-38. IEEE.

- Phan, Yang, Clark, Grosu, Schierman, Smolka, & Stoller. (2017). A component-based simplex architecture for high-assurance cyber-physical systems. . arXiv:1704.04759.
- Pinker. (2021). *Rationality*. Viking.
- Pulina, T. (2010). An Abstraction-Refinement approach to verification of artificial neural networks. *CAV*.
- Putzer, W. (2020). Trustworthy Autonomous/Cognitive Systems: A Structured Approach. *fortiss Whitepaper*. ISSN 2699-1217.
- Raedt, d., Manhaeve, & Dumancic. (2019). Neuro-Symbolic = Neural + Logical + Probabilistic. *NeSy'19@IJCAI, the 14th International Workshop on Neural-Symbolic Learning and Reasoning*.
- Riegel, & et.al. (2020). Logical neural networks. arXiv:2006.13155.
- Robinson. (2008). Entropy and Uncertainty. *Journal of Entropy, ISSN 1099-4300*.
- Rodd. (1994, Dez). Safe AI - is this possible? *IFAC Proceedings Volume*. Elsevier.
- Ruan, Huang, & Kwiatkowska. (2018). Reachability analysis of deep neural networks with provable guarantess. arXiv:1805.02242.
- Rushby. (1988). Quality measures and assurance for AI software. *NASA Contractor Report 4187*.
- Rushby. (2010). Formalism in safety cases. . *Making systems safer*.
- Rushby. (2013). Logic and epistemology in safety cases. *SafeComp*.
- Rushby. (2018). Assurance for Increasingly Autonomous Safety Critical Systems. <http://www.csl.sri.com/users/rushby/slides/fomlas18.pdf>.
- Rushby. (2020). The Indefeasibility Criterion for Assurance Cases. *NII Shonan Workshop*.
- Sagel, Sahu, Matthes, Pfeifer, Qiu, Rueß, . . . Wörmann. (2020). Knowledge as Invariance -- History and Perspectives of Knowledge-augmented Machine Learning. arXiv:2012.11406.
- Sahu, Váñez, Rodríguez-Bobada, Alhaddad, Moured, & Neugschwandtner. (2020). Application of the neural network dependability kit in real-world environments. arXiv:2012.09602.
- Salay, & Czarnecki. (2018). Using machine learning safely in automotive software: An assessment and adaption of software process requirements in ISO 26262. arXiv:1808.01614.
- Schiemann, DeVore, Richards, Gandhi, Cooper, Horneman, . . . Smolka. (2001). Runtime assurance framework development for highly adaptive flight control systems,. *Technical Report*. Charlottesville: Barron Associates Inc.
- Schwalbe, & Schels. (2020). A Survey on Methods for the Safety Assurance of Machine Learning Based Systems. *10th European Congress on Embedded Real Time Software and Systems (ERTS)*.
- Sculley, Holt, Golovin, Davydov, Phillips, Ebner, & Young. (2014). Machine learning: The high interest credit card of technical debt. *SE4ML: Software Engineering for Machine Learning (NIPS Workshop)*. <http://research.google/pubs/pub43146/>.
- Seshia, Desai, Dreossi, Fremont, Ghosh, Kim, & Yue. (2018). Formal Specification for Deep Neural Networks. *International Symposium on Automated Technology for Verification and Analysis* . Springer.
- Seshia, Desai, Dreossi, Fremont, Ghosh, Kim, & Yue. (2018). Formal Specification for Deep Neural Networks. *International Symposium on Automated Technology for Verification and Analysis (ATVA)*, 20-34.
- Seshia, Sadigh, & Sastry. (2016). Towards Verified Artificial Intelligence. arXiv:1606.08514.
- Sha. (2001). Using simplicity to control complexity. *IEEE Software, 18(4), pp. 20-28*. IEEE.
- Shalev-Schwartz, Shammah, & Shashua. (2018). Vision Zero: Can Roadway Accidents be Eliminated without Compromising Traffic Throughput. <https://export.arxiv.org/abs/1901.05022>.



- Shen, Wan, & Chen. (2018). MuNN: Mutation analysis of neural networks. *IEEE International Conference on Software Quality, Reliability and Security Companion (QRS-C)*, pp. 108-115. IEEE.
- SOTIF. (2017). ISO/PAS 21448:2018, Road Vehicles – Safety of the Intended Functionality. Draft.
- Sotoudeh, & Thakur. (2019). A Symbolic neural network representation and its application to understanding, verifying, and patching networks. *arXiv:1908.06223*.
- Su, Vargas, & Sakurai. (2019). One pixel attack for fooling deep neural networks. *IEEE Transactions on Evolutionary Computation*, 23(5), pp. 828-841.
- Sun, Huang, Kroening, Sharp, Hill, & Ashmore. (2019). Testing deep neural networks. *arXiv:1803.04792v4*.
- Sun, Wu, Ruan, Huang, Kwiatkowska, & Kroening. (2018). Concolic testing for deep neural networks. *Proceedings of the 33rd ACM/IEEE International Conference on Automated Software Engineering*. IEEE.
- Swiler, Paez, & Mayes. (2009). Epistemic uncertainty quantification tutorial. *Proceedings of the 27th International Modal Analysis Conference*.
- Tambon, Laberge, An, Nikanjam, & et.al. (2021). How to Certify Machine Learning Based Safety-critical Systems? *Arxiv 2107.12045*.
- Thati, & Roşu. (2005). Monitoring algorithms for metric temporal logic specifications. *Electronic Notes in Theoretical Computer Science*, 113, pp. 145-162.
- Tiwari, Dutertre, Jovanović, Candia, d., Lincoln, Rushby, & Seshia. (2014). Safety Envelope for Security. *roceedings of the 3rd international conference on High confidence networked systems*, pp. 85-94.
- Torfah, Junges, Fremont, & Seshia. (n.d.). Formal Analysis of AI-Based Autonomy: From Modeling to Runtime Assurance. *International Conference on Runtime Verification*, pp. 311-330., (p. Springerr).
- Tuncali, Ito, Kapinski, & Deshmukh. (2018). Reasoning about safety of learning-enabled components in autonomous cyber-physical systems. *Proceedings of the 55th Annual Design Automation Conference (DAC)*, pp. 1-6.
- UK Ministry of Defence:. (2007). Defence Standard 00-56, Issue 4: Safety Management Requirements for Defence Systems. Part 1: Requirements.
- Weyns, Bencomo, Calinescu, & et.al. (n.d.). Perpetual Assurances for Self-Adaptive Systems. *Arxiv 1903.04771*.
- Xiang, Musau, Wild, Lopez, Hamilton, Yang, & Johnson. (2018). Verification for machine learning, autonomy, and neural networks survey. *arXiv:1810.01989*.
- Xie, Ma, Juefei-Xu, Chen, Xue, Li, & See. (2018). Coverage-guided fuzzing for deep neural networks. *arXiv:1809.01266*.
- Xin, & Rueß. (2021). Actor-based Synthesis for Timed GXW. (*Submitted for Publication*).
- Yamamoto. (2015). Assuring security through attribute GSN. *5th International Conference on IT Convergence and Security (ICITCS)*, pp. 1-5.
- Zhang, Zhang, Liu, & Khurshid. (2018). Deep-Road: GAN-based metamorphic autonomous driving system testing. *33rd IEEE/ACM International Conference on Automated Software Engineering (ASE)*, pp. 132-142. IEEE.
- Zhao, Huang, Bharti, Dong, Cox, Banks, . . . Huang. (2021). Reliability assessment and safety arguments for machine learning components in assuring learning-enabled autonomous systems. *arXiv:2112.00646*.
- Zhao, Littlewood, Povyakalo, Strigini, & Wright. (2017). Modelling the probability of failure on demand (pfd) of a 1- out-of-2 system in which one channel is “quasi-perfect”. *Reliability Engineering & System Safety*, 158, pp. 230-245.

Zhao, Zhang, Lu, & Zeng. (2012). A new approach to assessment of confidence in assurance cases. *International Conference on Computer Safety, Reliability, and Security*, pp. 79-91 . Springer.