

# Long-Term Benefits of Network Boosters for Renewables Integration and Corrective Grid Security

Amin Shokri Gazafroudi<sup>a,\*</sup>, Elisabeth Zeyen<sup>b</sup>, Martha Frysztacki<sup>a</sup>, Fabian Neumann<sup>b</sup>, Tom Brown<sup>b</sup>

<sup>a</sup>*Institute for Automation and Applied Informatics, Karlsruhe Institute of Technology (KIT), 76131 Karlsruhe, Germany*

<sup>b</sup>*Institute of Energy Technology, Technical University of Berlin, Einsteinufer 25, 10587 Berlin, Germany*

---

## Abstract

The preventative strategies for  $\mathcal{N} - 1$  network security dominant in European networks mean that network capacity is kept free in case a line fails. If instead fast corrective actions are used to overcome network overloading when single lines fail, this has the potential to free up network capacity that is otherwise underused in preventive  $\mathcal{N} - 1$  security strategies. In this paper, we investigate the impact on renewable integration of a corrective network security strategy, whereby storage or other flexibility assets are used to correct overloading shortly after line outages. In this way, we find significant cost savings for the integration of renewable energy of up to 2.4 billion euros per year in a aggregated 50-bus model of the German power system utilizing these flexibility assets, so-called *network boosters* (NB). This offers a role for storage beyond energy arbitrage or ancillary services like frequency control. While previous literature has focused on the potential savings of NB in the short-term operation, we focus on the long-term benefits in systems with high shares of renewable energy sources, where the capacities and dispatch of generation and NB are optimised. We demonstrate the benefits of NB for various shares of renewable energy, NB and flexibility costs, as well as different allowed levels of temporary overloading the lines in both (i) a sequential model, where long-run generation investments are optimised separately from the NB capacities, and (ii) a simultaneous model, where generation is co-optimised with NB investment so that mixed preventive-corrective approaches are possible.

*Keywords:* Contingency, flexibility, network booster, power transmission system, reliability, security-constrained optimal power flow.

---

## 1. Introduction

### 1.1. Background

Traditional preventative approaches to the  $\mathcal{N} - 1$ -secure operation of transmission networks keep power flows in transmission lines below line capacities so that if a line fails, no other line in the network becomes overloaded. This leads to the under-utilization of network assets and hinders the economic integration of generation sources, particularly those like wind and solar that are transported over long distances. In Europe, such preventative approaches dominate strategies for  $\mathcal{N} - 1$  network security. An alternative corrective approach is to react to the line failure only after it happens, by activating flexibility resources such as storage or demand-side management to counter-act any overloading that results in the rest of the network [1]. Thus, flexibility assets act within minutes to prevent long-term overloading. This corrective approach allows a higher utilization of the transmission network, and could benefit the integration of renewable energy

---

\*Corresponding author

*Email addresses:* shokri.g.amin@gmail.com (Amin Shokri Gazafroudi), e.zeyen@tu-berlin.de (Elisabeth Zeyen), martha.frysztacki@kit.edu (Martha Frysztacki), f.neumann@tu-berlin.de (Fabian Neumann), t.brown@tu-berlin.de (Tom Brown)

sources (RESs), particularly in regions where transmission expansion is slow because of public acceptance problems. In addition, corrective network security offers an additional revenue stream to assets like batteries, besides regular energy arbitrage and ancillary services such as reserves.

### 1.2. Literature review

Several studies have investigated the role of contingency constraints as well as flexibility resources in power transmission systems. For instance, operational flexibility and  $\mathcal{N} - 1$  constraints for transmission lines were considered in a combined generation and transmission planning approach in [2]. Authors in [3] applied a non-linear security constrained optimal power flow (SCOPF) model with mixed preventive-corrective contingency measures, finding a role for both preventive and corrective actions. Authors in [4] discussed a framework to employ operational flexibility among transmission system operators (TSOs) in multi-area power systems subject to  $\mathcal{N} - 1$  security criteria. Authors in [5] proposed a corrective approach to solve a  $\mathcal{N} - 1$  security-constrained unit commitment problem to minimize congestion of transmission lines and curtailment of RESs. Authors in [6] presented a corrective approach to avoid line overloading. In [7], re-dispatching of flexible resources is used in the context of SCOPF as a corrective strategy in response to line outages. A preventive approach has been utilized by authors in [8], where  $\mathcal{N} - 1$  security conditions have been approximated based on the network's topology by analysing the polytope of feasible nodal net power injections under contingency constraints to reduce the problem's computational burden. Similarly, authors in [9] introduced a geometric algorithm based on the feasible space of net power injections for reducing the number of preventive contingency constraints.

While the mathematical formulation of preventive and corrective security-constrained optimal power flow is well understood [10, 11], most investigations of the benefits of corrective security have focused on short-term cost reductions in the operation of the power system where the investments in generation and flexibility assets are fixed. For example, it was shown in [12] that corrective actions can significantly reduce the costs of maintaining operational security in a case study with the 24-bus IEEE reliability test system. Benefits of a corrective approach were also found in a European case study that showed that investment in corrective controls was complementary to transmission expansion [13], but generation capacities were once again exogenous. High share of renewable generation were considered in a multi-period stochastic context with both preventative and corrective network security in [14], but the impact on generation planning was not considered. In the German context, several recent studies have shown that corrective measures could lead to a significant reduction in congestion management measures such as redispatch [15, 16]. Transmission-connected battery systems that perform these corrective actions have been called *network boosters* (NB) by the German transmission system operators [17]. In [18] it was shown that there are significant distributed flexibility potentials on the demand side too, including up to 16 GW of upward flexibility potentials from power-to-heat units in district heating networks.

### 1.3. Contributions

While previous research has included storage capacities in generation planning for energy arbitrage between time periods or ancillary services [19, 20, 21, 22], we propose a planning model that for the first time uses the storage and flexible systems as NB resources for corrective network security. This approach avoids having to maintain free network capacity preventatively and thereby allows lines to be fully loaded. Additionally, we explore the longer-term impact of a corrective approach to  $\mathcal{N} - 1$  security on the distribution of generation capacities within Germany in this paper. By freeing up grid capacity, network boosters allow wind and solar generation to be placed at sites with better capacity factors, thus reducing the overall costs of the power system. This impact is expected to be particularly high in countries like Germany, where network expansion is known to experience long delays [23], putting pressure on grid operators to maximise the use of existing assets. We explore the benefit as a function of different levels of renewable energy, as a function of the network booster cost and as a function of the allowed temporary overloading of the lines before the network booster can be activated.

Our main contributions are:

- to present a model that co-optimizes network booster placement with generation investment;

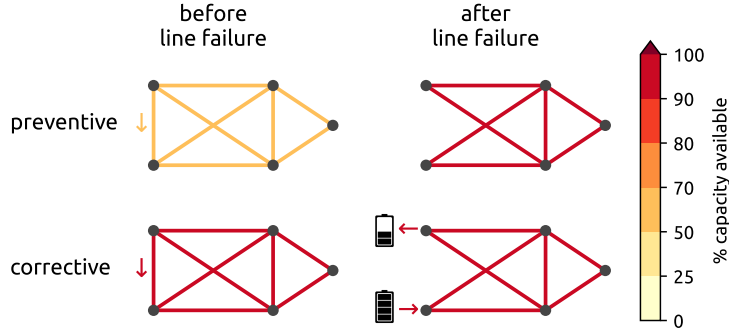

Figure 1: Illustration of the concept of preventive strategies to maintain network security under  $\mathcal{N} - 1$  conditions compared to network boosters as a corrective  $\mathcal{N} - 1$  security strategy.

- to explore the difference between an approach where generation and network booster capacities are optimized sequentially versus a simultaneous co-optimization that allows for mixed preventive-corrective security;
- to explore the dependency of network booster benefit on CO<sub>2</sub> reduction targets, which are a proxy for renewable penetration in the German context;
- to analyse the effect of the cost of network boosters (particularly relevant given the uncertainty of battery costs and the possible substitution of batteries with demand-side management);
- to investigate the sensitivity to the temporarily admissible transmission loading (TATL) of transmission lines.

Section 2 introduces the modelling of NB. In Section 3, TATL strategies for the NB are presented. Then, the performance of our proposed models are studied in Section 4. We draw attention to the limitations of the modelling in Section 5. Finally, our findings are concluded in Section 6.

## 2. Network Booster Modelling

First, we introduce our generalized network booster (NB) model to investigate possible benefits of a corrective  $\mathcal{N} - 1$  strategy compared to preventative  $\mathcal{N} - 1$  security. The network boosters work by injecting or withdrawing power from the grid within minutes after a line fails, so that no other line becomes overloaded. Lines may be temporarily overloaded for the few minutes it takes the network booster to come into operation.

The objective of the mathematical problem is to minimize the total required NB capacity at all buses so that we can retain the security of the network considering all single line failures as illustrated in Fig. 1. The proposed NB problem optimizes the capacity to adjust power or demand.  $P_i^+$  represents the upward NB capacity to increase power or reduce demand at bus  $i$ ,  $P_i^-$  the downward NB capacity to decrease power or increase demand at bus  $i$ . Thus, both upward and downward NB capacities are positive:

$$P_i^+ \geq 0, \quad \forall i, \quad (1)$$

$$P_i^- \geq 0, \quad \forall i. \quad (2)$$

The dispatch variables of the NB resources  $p_{i,t,\ell}^+$  and  $p_{i,t,\ell}^-$  are defined at bus  $i$  in time  $t$  for the outage of line  $\ell$  to be positive and limited to the upward and downward NB capacities respectively:

$$0 \leq p_{i,t,\ell}^+ \leq P_i^+, \quad \forall i, \forall t, \forall \ell. \quad (3)$$

$$0 \leq p_{i,t,\ell}^- \leq P_i^-, \quad \forall i, \forall t, \forall \ell. \quad (4)$$

The total power injected into the network by all NB resources is equal to the total power absorbed from the network from NB resources, assuming a lossless transmission network:

$$\sum_i \left( p_{i,t,\ell}^+ - p_{i,t,\ell}^- \right) = 0, \quad \forall t, \forall \ell. \quad (5)$$

Finally, the minimum and maximum constraints for avoiding overloading in transmission line  $\ell$  when line  $k$  fails by operating NB resources under  $\mathcal{N} - 1$  security condition is given by:

$$\begin{aligned} -F_\ell &\leq f_{\ell,t} + LODF_{\ell k} f_{k,t} \\ &+ \sum_i \left[ (PTDF_{\ell i} + LODF_{\ell k} PTDF_{ki}) (p_{i,t,k}^+ - p_{i,t,k}^-) \right] \\ &\leq F_\ell, \quad \forall t, \forall k, \forall \ell \neq k, \end{aligned} \quad (6)$$

where  $f_{\ell,t}$  represents the power flow in line  $\ell$  at time  $t$  before the outage of line  $k$  and  $F_\ell$  is the nominal power capacity of transmission line  $\ell$ , also called the *Permanently Admissible Transmission Loading (PATL)*. The *PTDF* matrix represents the *Power Transfer Distribution Factors* which relate nodal power injections to the line flows [24]. The *LODF* matrix introduces the *Line Outage Distribution Factors* [25, 26] that measure the sensitivity of line flows to the outage of other lines

$$LODF_{\ell,k} = \frac{[PTDF \cdot K]_{\ell,k}}{1 - [PTDF \cdot K]_{\ell,\ell}}. \quad \forall \ell, \quad (7)$$

If  $\ell = k$ , we define  $LODF_{\ell,k} = -1$ .  $K_{i,\ell}$  denotes the incidence matrix of the transmission grid which has non-zero values +1 if line  $\ell$  starts at bus  $i$  and -1 if line  $\ell$  ends at bus  $i$ . The orientation of the lines is arbitrary but fixed.

The first two terms in Eq. (6) give the power flow in line  $\ell$  immediately after the outage of line  $k$ , while the sum computes the effect of the network boosters on the power flow to counteract the effects of the outage. It is assumed that it may take several minutes to activate the network boosters. In the meantime, we assume that the transmission lines can be loaded more than their nominal power capacity, up to the so-called *Temporarily Admissible Transmission Loading (TATL)*, before the NB resources activate. It is notable that the steady state analysis and short-term dynamic analysis is not performed in our proposed model. This way, the relation between the TATL  $\tilde{F}_\ell$  and nominal power capacity (PATL) for line  $\ell$  is given by:

$$\tilde{F}_\ell = f^{tatl} F_\ell, \quad \forall \ell, \quad (8)$$

where  $f^{tatl}$  is the TATL factor, which is larger than one ( $f^{tatl} > 1$ ). In this way, if line  $\ell$  fails, some lines can become temporarily overloaded, until the NB resources act within a certain time, e.g. 2-5 minutes, to eliminate the overloading. Typical TATL values are 10-30% higher than the PATL [16]. Since the time until the NBs act depends on the NB installation and the time has an influence on the TATL, we provide a sensitivity analysis for the TATL. In addition, the NB resources need to be able to operate for a certain time, e.g. 30 minutes, to give time for re-dispatching measures such as reducing wind feed-in or firing up gas power plants. To ensure that no line  $\ell$  is loaded above the TATL after the failure of line  $k$ , additional constraints must be enforced:

$$|f_{\ell,t} + LODF_{\ell k} f_{k,t}| \leq \tilde{F}_\ell \quad \forall k, \ell \neq k, t \quad (9)$$

### 3. Network Booster Planning Approaches

In this section, we propose two strategies for optimizing the size and placement of network boosters along with the long-term electricity generation fleet. The first *sequential* strategy separates the problem into a long-term generation capacity expansion problem where it is assumed that network boosters take care of  $\mathcal{N} - 1$  security correctively, followed by a separate problem to determine the required investment in the

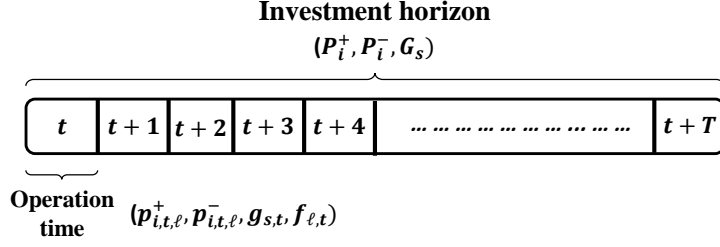

Figure 2: Operation and investment time horizons for the discussed network booster strategies.

network boosters. From a market perspective, this could represent the separation of long-term generation investment from the secure operation of the grid by the network operator. In the simultaneous problem, investment in generation and network boosters is optimized jointly, allowing mixed preventive-corrective strategies for  $\mathcal{N} - 1$  security. The related decision-making variables and their corresponding time horizons are illustrated in Fig. 2. Thus,  $p_{i,t,\ell}^+$ ,  $p_{i,t,\ell}^-$ ,  $g_{s,t}$  and  $f_{\ell,t}$  are operation decision-making variables for time  $t$ , and  $P_i^+$ ,  $P_i^-$  and  $G_s$  are investment decision-making variable over the studied time horizon. The combined network booster and generation planning problem is computationally demanding (requiring 100 GB memory for the German case study), which motivates the linearisation of all network and generation constraints.

### 3.1. Sequential Model

Our proposed sequential model splits into two stages. The first stage solves the electricity generation investment problem, while the NB placement problem is solved in the second stage. In this way, the power flow ( $f_{\ell,t}$ ) obtained from the investment problem is an input parameter of the NB placement problem.

#### 3.1.1. First Stage – Electricity Generation Investment Problem

The objective function for the electricity generation investment problem is to minimise annual system costs, composed of the capital and operation costs of the generation fleet:

$$\min_{G_s, g_{s,t}, f_{\ell,t}} \sum_s c_s G_s + \sum_{s,t} o_s g_{s,t}, \quad (10)$$

subject to (8), (9), (11) - (15),

where the first and second terms represent the capital and operation costs for generators, respectively.  $G_s$  represents the nominal power of generator  $s$  that can be built at an annual cost of  $c_s$ , and  $g_{s,t}$  represents the dispatched power of generator  $s$  at time  $t$ , which is multiplied with the marginal cost of operation  $o_s$ . As illustrated in Fig. 2,  $T + 1$  periods for representing demand and weather conditions are used to dimension the investment problem.

Furthermore, the investment problem is subject to some techno-economic and physical constraints which are presented in the following. Eq. (11) presents the balancing constraints, which require generation, demand and network flows to match at any bus  $i$  and at any time  $t$

$$\sum_s K_{i,s}^g g_{s,t} - d_{i,t} = \sum_{\ell} K_{i,\ell} f_{\ell,t}, \quad \forall t, \forall i, \quad (11)$$

where  $K_{i,s}^g$  represents the incidence matrix of generators for mapping generator  $s$  at bus  $i$ . Thus,  $K_{i,s}^g = 1$  if generator  $s$  is located at bus  $i$ , otherwise  $K_{i,s}^g = 0$ .  $K_{i,\ell}$  denotes the incidence matrix of the transmission grid, as previously noted.

The capacities of generation are constrained by a maximum installable potential  $\bar{G}_s$ :

$$0 \leq G_s \leq \bar{G}_s, \quad \forall s. \quad (12)$$

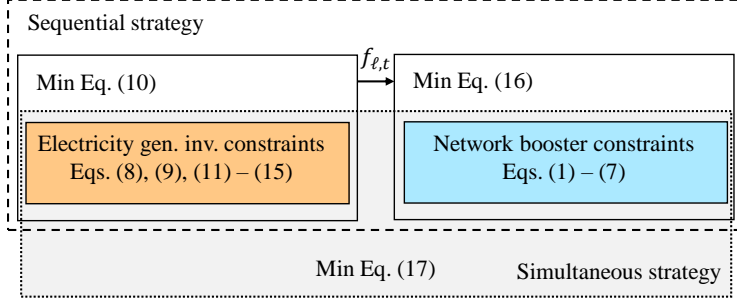

Figure 3: Problem formulations for the proposed sequential and simultaneous network booster strategies.

Moreover, maximum and minimum limitations of dispatched power of generators are expressed by

$$0 \leq g_{s,t} \leq \bar{g}_{s,t} G_s, \quad \forall s, \forall t, \quad (13)$$

where  $\bar{g}_{s,t}$  represents the time-dependent availability factor for power dispatch given in per unit of the generator's capacity. This is relevant for modelling variable renewables like wind and solar. Similarly, the absolute power flow in lines is constrained to their permanent transmission line capacities (PATL):

$$-F_\ell \leq f_{\ell,t} \leq F_\ell, \quad \forall \ell, \forall t. \quad (14)$$

Furthermore, the model features a constraint that limits the CO<sub>2</sub> emissions to a desired target level,  $\Gamma_{\text{CO}_2}$ .

$$\sum_{s,t} \frac{e_s}{\eta_s} g_{s,t} \leq \Gamma_{\text{CO}_2}, \quad (15)$$

where  $e_s$  denotes the specific emissions of the fuel,  $\eta_s$  is the generator efficiency. This model formulation classifies as linear problem (LP).

### 3.1.2. Second Stage – Network Booster Problem

In the second stage of the sequential model, the NB placement problem is solved globally based on the planned generation fleet and operation considering all single line outages. With the equations from the generalized NB model as described in Section 2, we seek to minimize the total cost of network booster investment and operation:

$$\begin{aligned} \min_{p_{i,t,\ell}^+, p_{i,t,\ell}^-, P_i^+, P_i^-} & \sum_i (c^+ P_i^+ + c^- P_i^-) \\ & + \sum_{i,t,\ell} (o^+ p_{i,t,\ell}^+ + o^- p_{i,t,\ell}^-), \end{aligned} \quad (16)$$

subject to (1) - (7),

where  $c^+$  ( $c^-$ ) represents cost for upward (downward) NB capacity. The coefficients  $o^+$  and  $o^-$  represent the compensation cost paid to the NB resources, i.e. demand side management consumers, or running costs for energy storage system, for dispatching when lines failed in the transmission network. Moreover, it is important to note that  $f_{\ell,t}$  is a model input rather than a decision variable in this second stage. Values for  $f_{\ell,t}$  are taken from the first stage and used as an exogenous parameter of the second stage in the sequential NB problem. This model formulation is a linear problem (LP) as well.

### 3.2. Simultaneous Model

Our proposed simultaneous model for the NB problem is an alternative to the sequential model. In this simultaneous model, the electricity generation investment problem and the generalized NB problem are co-optimized in a combined linear problem (LP). Thus, the objective function for TATL simultaneous NB problem is represented by:

$$\begin{aligned} \min_{G_s, g_{s,t}, f_{\ell,t}, p_{i,t,\ell}^+, p_{i,t,\ell}^-, P_i^+, P_i^-} & \sum_s c_s G_s + \sum_{s,t} o_s g_{s,t} \\ & + \sum_i (c^+ P_i^+ + c^- P_i^-) + \sum_{i,t,\ell} (o^+ p_{i,t,\ell}^+ + o^- p_{i,t,\ell}^-), \end{aligned} \quad (17)$$

subject to (1) - (9), (11) - (15),

where the power flow,  $f_{\ell,t}$ , is a decision-making variable in the simultaneous NB problem. The simultaneous model allows the decision-maker to choose between preventive and corrective measures for each line. If the decision-maker decides against a corrective strategy, it can set  $p_{i,t,\ell}^+ = p_{i,t,\ell}^- = 0$  and the Eq. (6) reverts to the standard preventive  $\mathcal{N} - 1$  constraint for an outage of line  $k$ . This endogenous choice between corrective and preventive strategies cannot be represented by the sequential model. The full problem formulations for sequential and simultaneous network booster strategies are summarized in Fig. 3.

## 4. Simulation Results

In this section, we study the performance of our proposed NB strategies in finding cost-efficient ways to protect network operation against line outages for a German test case, and observe where flexibility resources are optimally placed. The optimisations are run through the open source modelling framework PyPSA [27]. The results are evaluated in a 50-bus German transmission network using data from the open-source PyPSA-Eur model of the European transmission power system, including time-series for load and renewable availability for each region and existing power plants [28]. New investments are allowed at each location in wind, solar and fossil gas generation capacities.

Moreover, one hundred typical hours are chosen to represent typical demand and weather conditions. The hours are selected from historical data using the  $k$ -means algorithm and weighted according to their frequency of occurrence using the tsam library [29]. Different numbers of typical hours were initially investigated, but only above 50 hours were there enough representative time periods for the objective function to be stable as the temporal resolution was increased, indicating that the variability of wind and solar was correctly captured. Thus, one hundred hours were chosen since this was the upper limit for which we could solve the simultaneous model (the upper limit being the memory usage of 100 GB). It is also assumed that a nodal pricing regime is used for the dimensioning of generation assets.

The costs of the network boosters are based in the reference case on batteries with an energy capacity cost of 142 €/kWh and a power capacity cost of 160 €/kW, assuming an energy capacity equal to 30 minutes at full power. These cost assumptions are based on forecasts for the year 2030 from the Danish Energy Agency [30]. The costs are annualized assuming a cost capital of 7% to give an annualized cost of  $c^+ = c^- = C_f = 23$  €/kW/a (this cost includes 0.5 MWh of energy storage for every 1 MW of power). These costs are then varied in a sensitivity analysis. Very small operating costs of  $o^+ = o^-$  are assumed to avoid the batteries dispatching unless they are really needed, and to avoid simultaneous charging and discharging. The batteries with positive NB capacity are assumed to be fully charged before the outages, while the batteries with negative NB capacity are assumed to be completely empty before the outages.

The TATLs are uniformly assumed to be 30% higher than the PATLs in the default case, and are then varied in a sensitivity analysis. We study different levels of CO<sub>2</sub> emission reduction levels compared to levels in the year 1990 in the electricity sector.

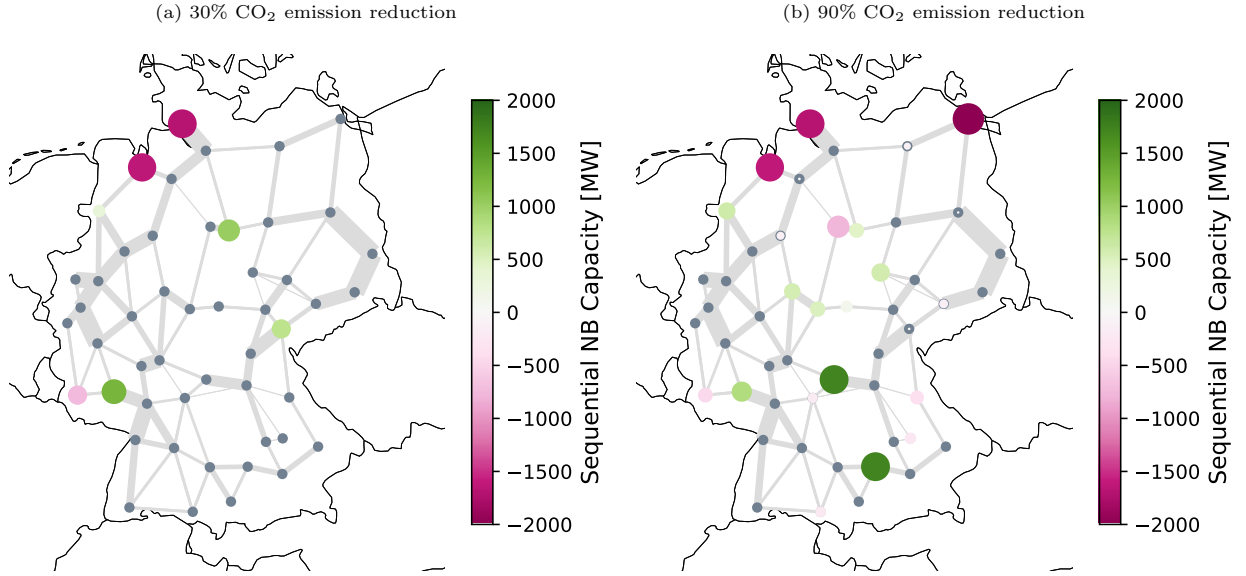

Figure 4: Impact of CO<sub>2</sub> emission reduction scenarios on map of allocated NB resources in the sequential model ( $f^{tatl} = 1.3$ ).

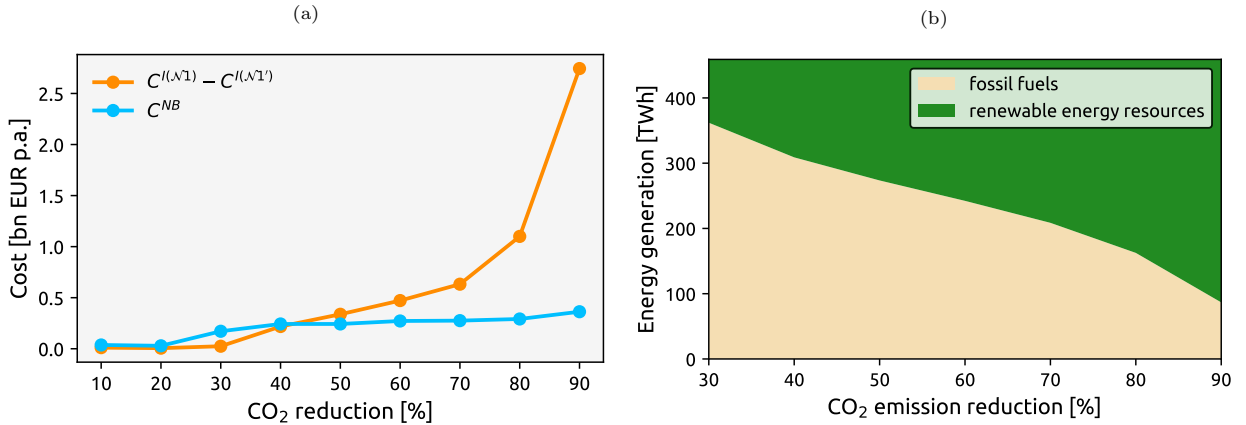

Figure 5: Impact of CO<sub>2</sub> emission reduction scenarios on (a) the NB cost ( $C^{NB}$ ) and the difference between investment cost of full  $\mathcal{N} - 1$  case and  $\mathcal{N} - 1'$  case with TATL ( $C^{I(\mathcal{N}-1)} - C^{I(\mathcal{N}-1')}$ ) with  $C_f = 23$  €/kW/a, (b) energy generation mix in the sequential model.

#### 4.1. Sequential model

In this section, the performance of the sequential model is assessed. In this way, the impacts of different CO<sub>2</sub> emission reduction scenarios and the TATL factor ( $f^{tatl}$ ) on system costs and allocated flexibility are studied in the power transmission system. Fig. 4 illustrates the map of allocated flexibility resources based on different CO<sub>2</sub> emission reduction scenario in the German transmission network where the positive values represent the discharge capacities ( $P_i^+$ ) and negative values represent charge capacities ( $-P_i^-$ ) of the network boosters. At no node are both upward  $P_i^+$  and downward  $P_i^-$  capacities installed. For a 90% CO<sub>2</sub> reduction, most of the downward capacity is installed in the North of Germany, to absorb power from the newly built wind farms, while the upward capacities are built in the South to supply the power gap that could not be transported. This reflects the dominant pattern of wind power flowing from North to South in the German system. The total capacity of allocated flexibility resources in the 90% CO<sub>2</sub> emission reduction scenario is 15.8 GW, which is 110% higher than total capacity of allocated flexibility resources in



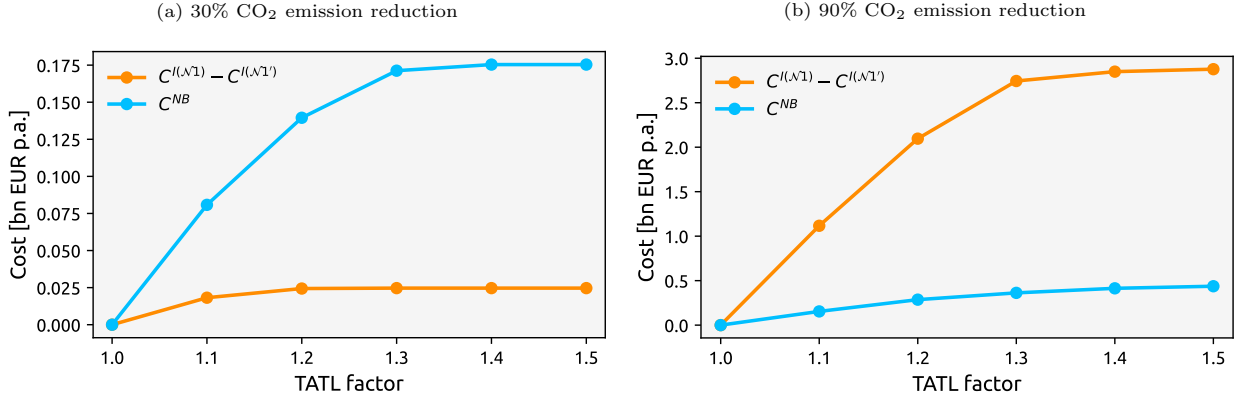

Figure 6: Impact of TATL factor on the NB cost ( $C^{NB}$ ) and different between investment cost of full  $\mathcal{N}-1$  case and  $(\mathcal{N}-1)'$  case with TATL ( $C^{I(\mathcal{N}-1)} - C^{I(\mathcal{N}-1)'}$ ) in the sequential model in (a) 30% (b) 90% CO<sub>2</sub> emission reduction scenarios with  $C_f = 23$  €/kW/a.

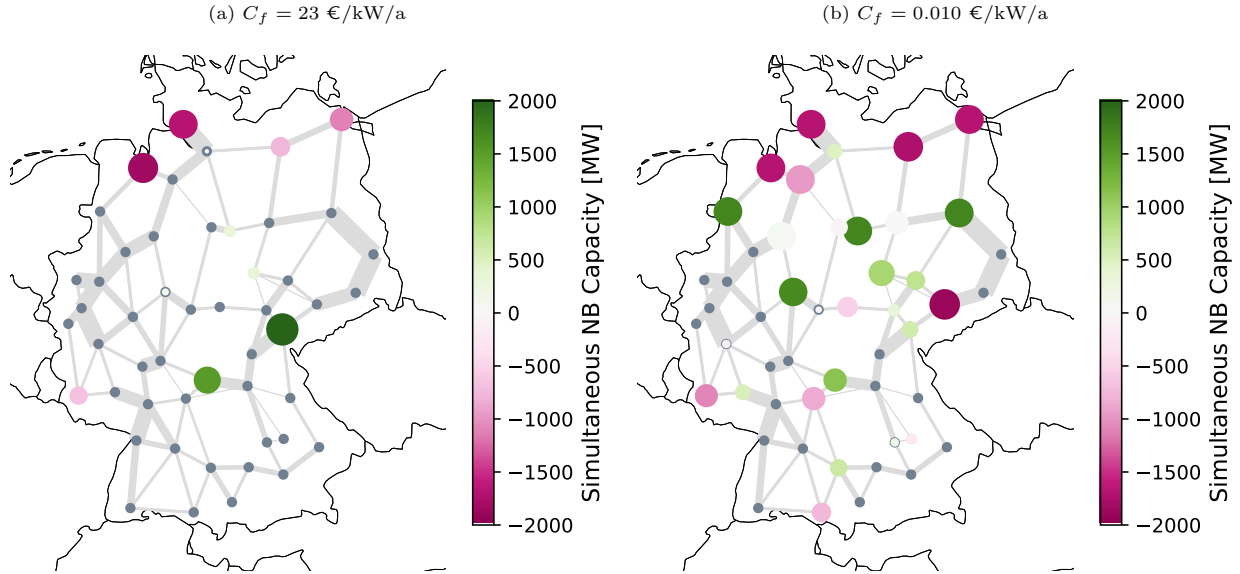

Figure 7: Impact of flexibility costs on allocated NB resources in the simultaneous model with  $f^{tatl} = 1.3$  in a 90% CO<sub>2</sub> emission reduction scenario.

the 30% CO<sub>2</sub> emission reduction scenario with  $f^{tatl} = 1.3$ , reflecting the higher wind share for the tighter CO<sub>2</sub> target.

To evaluate this trend systematically, Fig. 5(a) shows the sensitivity of varying the levels of CO<sub>2</sub> emission reduction on what is spent on network booster infrastructure ( $C^{NB}$ ) and the cost difference ( $C^{I(\mathcal{N}-1)} - C^{I(\mathcal{N}-1)'}$ ) between the generation infrastructure plan of the full preventive case  $\mathcal{N}-1$  (equivalent to  $f^{tatl} = 1$ ) and the preventive case relaxed by the TATL  $(\mathcal{N}-1)'$  with  $f^{tatl} = 1.3$  in the sequential model. As seen in Fig. 5(a),  $C^{NB}$  is less than the difference of  $C^{I(\mathcal{N}-1)} - C^{I(\mathcal{N}-1)'}$  for CO<sub>2</sub> emission reduction scenarios higher than  $\approx 42\%$ . In other words, investing in flexibility resources to boost the network is beneficial compared to investing in electricity generation even for moderate CO<sub>2</sub> emission reduction levels. Fig. 5(b) shows the amount of energy produced from renewable energy resources compared to fossil fuel generation.

Additionally, the impact of varying the TATL factor on the NB cost and difference between investment cost of full  $\mathcal{N}-1$  and  $\mathcal{N}-1'$  cases considering 30% and 90% CO<sub>2</sub> emission reduction scenarios in the

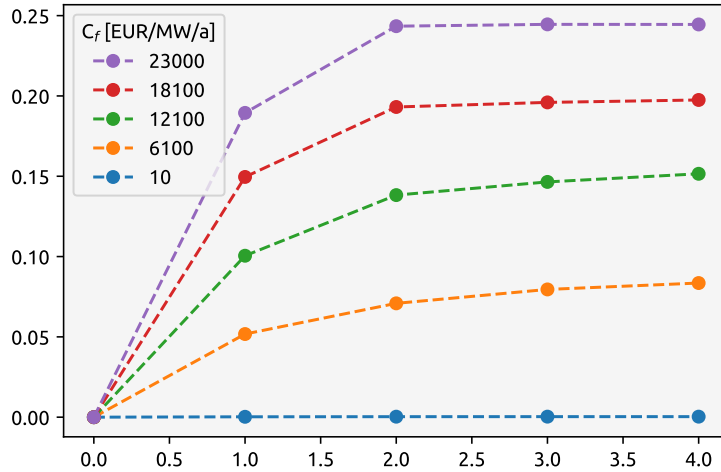

Figure 8: Impact of  $f^{tatl}$  on the NB cost ( $C^{NB}$ ) under various flexibility costs in the simultaneous model for a 90% CO<sub>2</sub> emission reduction scenario.

sequential model are illustrated in Figs. 6 (a) and (b), respectively. Raising the TATL factor increases both  $C^{NB}$  and  $C^{I(\mathcal{N}-1)} - C^{I(\mathcal{N}-1')}$ . The difference between  $C^{I(\mathcal{N}-1)} - C^{I(\mathcal{N}-1')}$  and  $C^{NB}$  is increased with rising TATL factors, until this difference stabilizes for TATL factors above 1.3. A similar result was also seen for the German grid in [16], where a TATL factor of 1.2 allows most of the benefits of an infinite TATL to be obtained.

#### 4.2. Simultaneous model

In this section, the performance of the proposed simultaneous model is evaluated, while addressing sensitivities regarding CO<sub>2</sub> emission reduction levels, flexibility cost ( $C_f$ ), and the TATL factor. Fig. 7 displays a map of cost-optimally allocated NB infrastructure in a 90% CO<sub>2</sub> emission reduction scenario for the highest and lowest considered flexibility costs. With  $C_f = 23$  €/kW/a in the 90% CO<sub>2</sub> emission reduction scenario, the total NB capacity drops from the 15.8 GW built in the sequential model to 10.5 GW for the simultaneous model, indicating that in the simultaneous case the optimizer is choosing not to use corrective security for all line outages. However, the figure shows that considerably more NB infrastructure is built if flexibility costs are lower, with NB capacity rising from 10.5 GW to 31 GW. As previously observed for the sequential model, power consuming network boosters are predominantly found North of the power supplying network boosters in both shown cases. Additionally, Fig. 8 shows how the TATL factor impacts the investment in network booster infrastructure for a 90% CO<sub>2</sub> emission reduction scenario for various levels of flexibility costs. The figure illustrates how increasing TATL factors make network boosters more attractive across all flexibility cost levels. Analogous to the sequential model, the investment in NB resources stabilises at TATL factors of 1.3 and beyond. The total investment in network booster infrastructure amounts to 0.24 billion Euros per year for the most conservative flexibility cost estimates.

#### 4.3. Cost benefits of corrective over preventive measures

In this section, the costs of the system based on sequential and simultaneous models are compared to a system that is secured by standard preventive  $\mathcal{N} - 1$  security constraints. Fig. 9 illustrates the total system cost comprising electricity generation investment, operation, and the NB costs for different CO<sub>2</sub> reduction targets.

The advantage of the simultaneous model is that it can choose for each line failure a mixture of preventive and corrective measures. For a low CO<sub>2</sub> target of 30% there are low levels of wind and network loading, so the simultaneous model does not build any network boosters and it is cost-optimal to apply a preventative strategy everywhere equivalent to the standard  $\mathcal{N} - 1$  case. For a target of 50%, some network booster

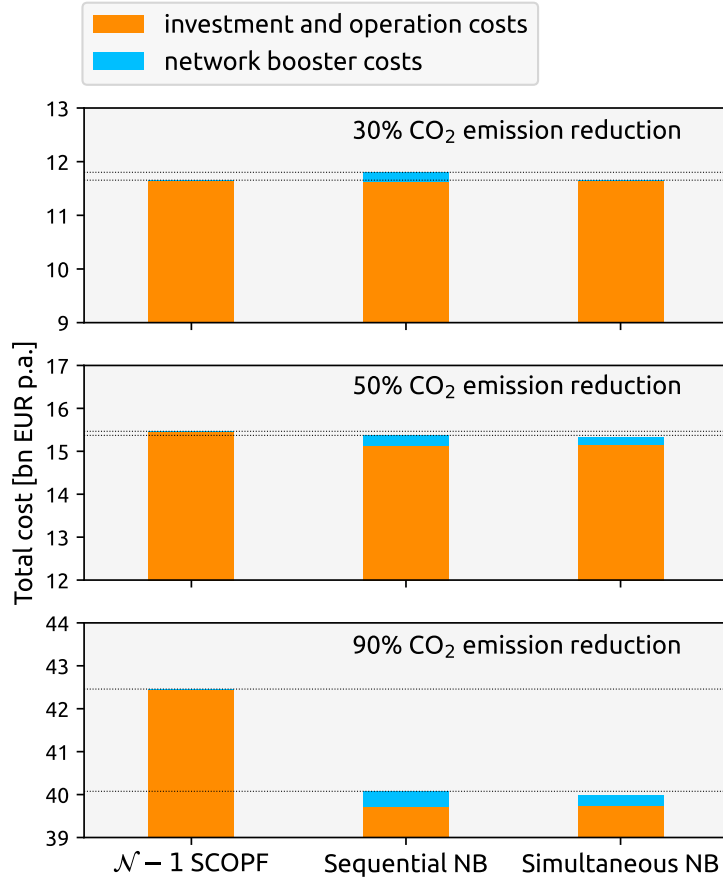

Figure 9: Comparison between total costs of the sequential and simultaneous strategies (with  $f^{tatl} = 1.3$  and  $C^f = 23$  €/kW/a) and SCOPF  $\mathcal{N} - 1$  for three different CO<sub>2</sub> emission reduction targets of 30% (top), 50% (center) and 90% (bottom).

capacity appears in the cost-optimal solution, but only 65% of the total NB capacity of the sequential model is built. Instead, a selective preventive-corrective strategy is applied which sits between the standard  $\mathcal{N} - 1$  case and the full sequential NB case. This results in costs which are below both extreme cases. Similarly, for a 90% CO<sub>2</sub> reduction the simultaneous model chooses a mixed preventative-corrective strategy with lower NB capacity than the sequential model. However, the total system costs are more (or less) identical to the sequential NB model which applies a corrective strategy for all line failures. There is a substantial annual cost saving of 2.4 billion euros from moving from preventive to corrective security. There is an overall cost benefit of just 0.25% of the simultaneous model over the sequential model, which indicates that there is only a small advantage to having a mixed preventative-corrective approach compared to the purely corrective approach in the sequential model. In addition, the sequential model has a clearer separation between generation, planning and network security which may be advantageous from perspective of the power network regulatory.

## 5. Limitations and Future Work

Our model contains several simplifications that are necessary to co-optimize generation and network booster capacities within limited computational resources. The bottleneck is the computer memory, since the simultaneous model case study for Germany required 100 GB of RAM. Without these simplifications the optimisation would not have been possible, but the simplifications may affect the results. For example,

the power flow has been linearized, but this neglects reactive power flows and losses, which should be examined using the full non-linear power flow equations. Unit commitment, discrete generation expansion and intra-day uncertainty have been ignored. Similarly we have ignored short-term dynamics that could result from the fast activation of the network boosters, as well as the possible benefits of topology switching to deload the network after a line failure. We have focused on the long-term benefits of the network booster assuming that the current single bidding zone for Germany with subsequent nodal redispatch is replaced by a single market clearing process with nodal power markets. There may be additional benefits for network boosters in today’s system where market dispatch is separated from congestion management. On the other hand, planned network expansion may reduce the benefit from network boosters. It is possible that network boosters can also be used for energy arbitrage in the spot market or to provide reserves, adding possible revenue streams and making the business case more attractive.

## 6. Conclusion

In this paper, we have explored the long-term benefits of a corrective strategy towards line failures compared to a traditional preventive security approach. We have examined both a sequential model, where network boosters are assumed to provide  $\mathcal{N} - 1$  security on all lines, and a simultaneous model which allows mixed preventive-corrective strategies depending on local conditions.

According to our simulation results on a 50-bus German transmission network, we found that using a corrective strategy frees up existing network capacities, allowing cost-saving investments in high quality renewable sites that bring total system cost savings of up to 2.4 billion euro per year for a 90% CO<sub>2</sub> reduction target. Even for lower targets, the selective use of network boosters is beneficial. For a high share of renewable energy sources, a widespread use of network boosters is optimal and there is only a small cost-benefit of the mixed preventive-corrective strategy of the simultaneous model. Moreover, it is found that once the temporarily admissible loading (TATL) rises 30% beyond the permanent rating, there is no additional cost saving, so that for lower TATL most of the advantages of the network booster are still gained.

## Acknowledgement

This paper was conducted as part of the CoNDyNet2 project, which was supported by the German Federal Ministry of Education and Research under grant number 03EK3055E.

## References

- [1] J. Zhao, T. Zheng, E. Litvinov, A unified framework for defining and measuring flexibility in power system, *IEEE Transactions on Power Systems* 31 (1) (2015) 339–347. doi:10.1109/TPWRS.2015.2390038.
- [2] W. Wang, M. Wang, R. Li, A transmission & generator expansion planning model considering flexibility and N-1 contingency, in: 2021 3rd Asia Energy and Electrical Engineering Symposium (AEEES), IEEE, 2021, pp. 268–272. doi:10.1109/AEEES51875.2021.9403002.
- [3] V. Bhardwaj, H. Ergun, D. Van Hertem, Risk-based preventive-corrective security constrained optimal power flow for AC/DC grid, in: 2021 IEEE Madrid PowerTech, IEEE, 2021, pp. 1–6. doi:10.1109/PowerTech46648.2021.9495030.
- [4] M. A. Bucher, S. Chatzivasileiadis, G. Andersson, Managing flexibility in multi-area power systems, *IEEE Transactions on Power Systems* 31 (2) (2015) 1218–1226. doi:10.1109/TPWRS.2015.2413387.
- [5] A. V. Ramesh, X. Li, Reducing congestion-induced renewable curtailment with corrective network reconfiguration in day-ahead scheduling, in: 2020 IEEE Power & Energy Society General Meeting (PESGM), IEEE, 2020, pp. 1–5. doi:10.1109/PESGM41954.2020.9281399.
- [6] Y. Zhang, Z. Xu, J. Kuang, Y. Han, L. Zheng, R. Guo, Corrective power network reconfiguration for eliminating transmission lines overload, in: 2020 IEEE 1st China International Youth Conference on Electrical Engineering (CIYCEE), IEEE, 2020, pp. 1–6. doi:10.1109/CIYCEE49808.2020.9332647.
- [7] A. Nikoobakht, J. Aghaei, M. Lotfi, J. P. Catalão, G. J. Osório, M. Shafie-khah, Flexible co-operation of tcsc and corrective topology control under wind uncertainty: An interval-based robust approach, in: 2019 IEEE Milan PowerTech, IEEE, 2019, pp. 1–6. doi:10.1109/PTC.2019.8810889.
- [8] A. S. Gazafroudi, F. Neumann, T. Brown, Topology-based approximations for N-1 contingency constraints in power transmission networks, *International Journal of Electrical Power & Energy Systems* (2021) 107702 doi:10.1016/j.ijepes.2021.107702.

- [9] R. Weinhold, R. Mieth, Fast security-constrained optimal power flow through low-impact and redundancy screening, *IEEE Transactions on Power Systems* 35 (6) (2020) 4574–4584. doi:10.1109/TPWRS.2020.2994764.
- [10] F. Capitanescu, J. M. Ramos, P. Panciatici, D. Kirschen, A. M. Marcolini, L. Platbrood, L. Wehenkel, State-of-the-art, challenges, and future trends in security constrained optimal power flow, *Electric Power Systems Research* 81 (8) (2011) 1731–1741. doi:10.1016/j.epsr.2011.04.003.
- [11] T. Van Acker, D. Van Hertem, Modeling preventive and corrective actions using linear formulation, in: *Dynamic Vulnerability Assessment and Intelligent Control For Sustainable Power Systems*, John Wiley & Sons, 2018, pp. 177–192. doi:10.1002/9781119214984.ch8.
- [12] G. Strbac, S. Ahmed, D. Kirschen, R. Allan, A method for computing the value of corrective security, *IEEE Transactions on Power Systems* 13 (3) (1998) 1096–1102. doi:10.1109/59.709105.
- [13] S. C. Müller, M. Osthuus, C. Rekowski, U. Häger, C. Rehtanz, Techno-economic evaluation of corrective actions for efficient attainment of (n- 1)-security in operation and planning, in: *2013 IEEE Power & Energy Society General Meeting*, IEEE, 2013, pp. 1–5. doi:10.1109/PESMG.2013.6672676.
- [14] M. I. Alizadeh, M. Usman, F. Capitanescu, Envisioning security control in renewable dominated power systems through stochastic multi-period "ac" security constrained optimal power flow, *International Journal of Electrical Power & Energy Systems* 139 (2022) 107992. doi:10.1016/j.ijepes.2022.107992.
- [15] A. Hoffrichter, K. Kollenda, M. Schneider, R. Puffer, Simulation of curative congestion management in large-scale transmission grids, in: *2019 54th International Universities Power Engineering Conference (UPEC)*, IEEE, 2019, pp. 1–6. doi:10.1109/UPEC.2019.8893627.
- [16] K. Kollenda, A. Hoffrichter, M. Schneider, A. Schrief, A. Moser, Planungsorientierte Simulation kurativer Maßnahmen im Deutschen Übertragungsnetz, in: *16. Symposium Energieinnovation (Graz)*, 2020.  
URL [https://www.tugraz.at/fileadmin/user\\_upload/tugrazExternal/4778f047-2e50-4e9e-b72d-e5af373f95a4/files/pr/Session\\_D1/415\\_PR\\_Kollenda.pdf](https://www.tugraz.at/fileadmin/user_upload/tugrazExternal/4778f047-2e50-4e9e-b72d-e5af373f95a4/files/pr/Session_D1/415_PR_Kollenda.pdf)
- [17] German TSOs, *Netzentwicklungsplan 2035 (2021)*.  
URL <https://www.netzentwicklungsplan.de/de/netzentwicklungsplaene/netzentwicklungsplan-2035-2021>
- [18] T. Kolster, R. Krebs, S. Niessen, M. Duckheim, The contribution of distributed flexibility potentials to corrective transmission system operation for strongly renewable energy systems, *Applied Energy* 279 (2020) 115870. doi:10.1016/j.apenergy.2020.115870.
- [19] T. Qiu, B. Xu, Y. Wang, Y. Dvorkin, D. S. Kirschen, Stochastic multistage coplanning of transmission expansion and energy storage, *IEEE Transactions on Power Systems* 32 (1) (2016) 643–651. doi:10.1109/TPWRS.2016.2553678.
- [20] C. J. Joubert, N. Chokani, R. S. Abhari, Impact of large scale battery energy storage on the 2030 central european transmission grid, in: *2018 15th International Conference on the European Energy Market (EEM)*, IEEE, 2018, pp. 1–5. doi:10.1109/EEM.2018.8469789.
- [21] M. M. Frysztacki, J. Hörsch, V. Hagenmeyer, T. Brown, The strong effect of network resolution on electricity system models with high shares of wind and solar, *Applied Energy* 291 (2021) 116726. doi:10.1016/j.apenergy.2021.116726.
- [22] L. Fiorini, G. A. Pagani, P. Pelacchi, D. Poli, M. Aiello, Sizing and siting of large-scale batteries in transmission grids to optimize the use of renewables, *IEEE Journal on Emerging and Selected Topics in Circuits and Systems* 7 (2) (2017) 285–294. doi:10.1109/JETCAS.2017.2657795.
- [23] ENTSO-E, *Ten year network development plan 2018: Executive summary: Connecting europe: Electricity, 2025 - 2030 - 2040*.  
URL <https://tyndp.entsoe.eu/tyndp2018/>
- [24] A. J. Wood, B. F. Wollenberg, G. B. Sheblé, *Power generation, operation, and control*, John Wiley & Sons, 2013.
- [25] J. Guo, Y. Fu, Z. Li, M. Shahidehpour, Direct calculation of line outage distribution factors, *IEEE Transactions on Power Systems* 24 (3) (2009) 1633–1634. doi:10.1109/tpwrs.2009.2023273.
- [26] V. Hinojosa, F. Gonzalez-Longatt, Stochastic security-constrained generation expansion planning methodology based on a generalized line outage distribution factors, in: *2017 IEEE Manchester PowerTech*, IEEE, 2017, pp. 1–6. doi:10.1109/PTC.2017.7981191.
- [27] T. Brown, J. Hörsch, D. Schlachtberger, PyPSA: Python for Power System Analysis, *Journal of Open Research Software* 6 (4) (2018). doi:10.5334/jors.188.
- [28] J. Hörsch, F. Hofmann, D. Schlachtberger, T. Brown, PyPSA-Eur: An open optimisation model of the european transmission system, *Energy Strategy Reviews* 22 (2018) 207–215. doi:10.1016/j.esr.2018.08.012.
- [29] M. Hoffmann, J. Priesmann, L. Nolting, A. Praktijnjo, L. Kotzur, D. Stolten, Typical periods or typical time steps? a multi-model analysis to determine the optimal temporal aggregation for energy system models, *Applied Energy* 304 (2021) 117825. doi:10.1016/j.apenergy.2021.117825.
- [30] *Technology Data for Generation of Electricity and District Heating*, Tech. rep., Danish Energy Agency (2022).  
URL <https://ens.dk/en/our-services/projections-and-models/technology-data>