

Semantic Coded Transmission: Architecture, Methodology, and Challenges

Jincheng Dai, *Member, IEEE*, Ping Zhang, *Fellow, IEEE*, Kai Niu, *Member, IEEE*, Sixian Wang, *Student Member, IEEE*, Zhongwei Si, *Member, IEEE*, Xiaoqi Qin, *Member, IEEE*

Abstract—Classical coded transmission schemes, which rely on probabilistic models and linear operations, have been always pursuing an elegant trade-off between effectiveness and reliability by source and channel coding techniques. However, a fundamental limit of these schemes is that they rarely take intelligent ingredients into consideration. In the future, communications toward intelligence and conciseness will predictably play a dominant role, and the proliferation of connected intelligent agents requires a radical rethinking of current coded transmission schemes to support the new communication morphology on the horizon. The recent concept of “semantic-driven” offers a promising research direction. Integrating semantic features in coded transmissions by nonlinear operations to achieve content-aware communications shows great potential for further breakthrough in effectiveness and reliability. Moreover, this form of coded transmission based on semantics is intuitively more consistent with essential demands of communications, i.e., conveying desired meanings or affecting conducts. This article aims to shed light on the emerging concept of semantic coded transmission (SCT), then present the general architecture and critical techniques of SCT, finally indicate some open issues on this topic.

I. BACKGROUND AND MOTIVATION

Since the masterpiece of C. E. Shannon was published in 1948 [1], the channel capacity formula has been serving as the guidance of communication system design for more than seven decades. Following that, the traditional system design philosophy, which upgrades transmission capability mainly by stacking more spectrum, higher-performance channel coding, higher-order modulation, denser access points, and larger-scale antennas with ever-increasing complexity, has contributed to the success from 1G to 5G. However, this traditional mode of outward-expansion will soon meet with its bottleneck in the current Post-Moore law era, where the speed of chip computing capability increasing cannot support the long-term sustainable development of wireless communications. Moreover, according to Weaver’s statement of the three levels of communications problems, current systems are still focusing on the fundamental Level A, i.e., merely solving the technical problem.

Future communication systems [2] envision that the wireless networks themselves contain intelligent and efficient ingredients, and communication terminals will become new intelligent agents. Nevertheless, current systems have not give sufficient considerations to these intelligent ingredients that indeed enlighten new possibilities and perspectives of further boost of effectiveness and reliability. This fact necessitates a radical rethinking of the communication system design that

should shift from the traditional outward-expansion mode to a new inward-discovery mode. As indicated by Weaver [3], communications problems involve not only technical aspects but also semantic aspects – Level B. These semantic aspects are inherent of a communication procedure and can be utilized for attaining potential gains of transmission efficiency. Specifically, the semantic problems are concerned with extracting, processing, and delivering the message meanings. Rather than the fidelity of the signal, it is more prominent to make the receiver have a proper comprehension of the intended meaning of the sender. From the point of practical implementation, we should actually put more focus on the transmitted content itself. By this approach, the coded transmission paradigm will upgrade from undifferentiated reliable transmissions to semantic-oriented biased transmissions.

Classical coded transmission in current systems refers to the scheme where various data is source-channel coded and modulated as signals transmitted over wireless channels. This procedure usually adopts explicit probabilistic models and linear operations, which indeed ignores the transmitted content itself. In contrast, semantic coded transmission (SCT) refers to a new scheme where the meaning of transmitted content and downstream tasks can be well identified to instruct the following coded transmission design. As we shall see, such a new communication paradigm depends critically on how to achieve a seamless collaboration between coding and semantic nonlinear transforms. In this article, we elaborate the insight of integrating deep learning based semantic information processing techniques with source-channel coded transmissions, present a brief tutorial on the basic concepts, general architecture, and key methodologies of SCT, and finally outline some future research directions.

II. THREE LEVELS OF COMMUNICATION PROBLEMS

As Weaver mentioned in his significant work [3], communications problems in a broad sense comprise three serially escalating levels as following:

- Level A. The technical problem: How accurately can the symbols of communication be transmitted?
- Level B. The semantic problem: How precisely do the transmitted symbols convey the desired meaning?
- Level C. The effectiveness problem: How effectively does the received meaning affect conduct in the desired way?

Dating back to over seven decades, Shannon has pioneered the classical information theory [1] to solve the pressing technical problem – Level A, which laid the foundation and

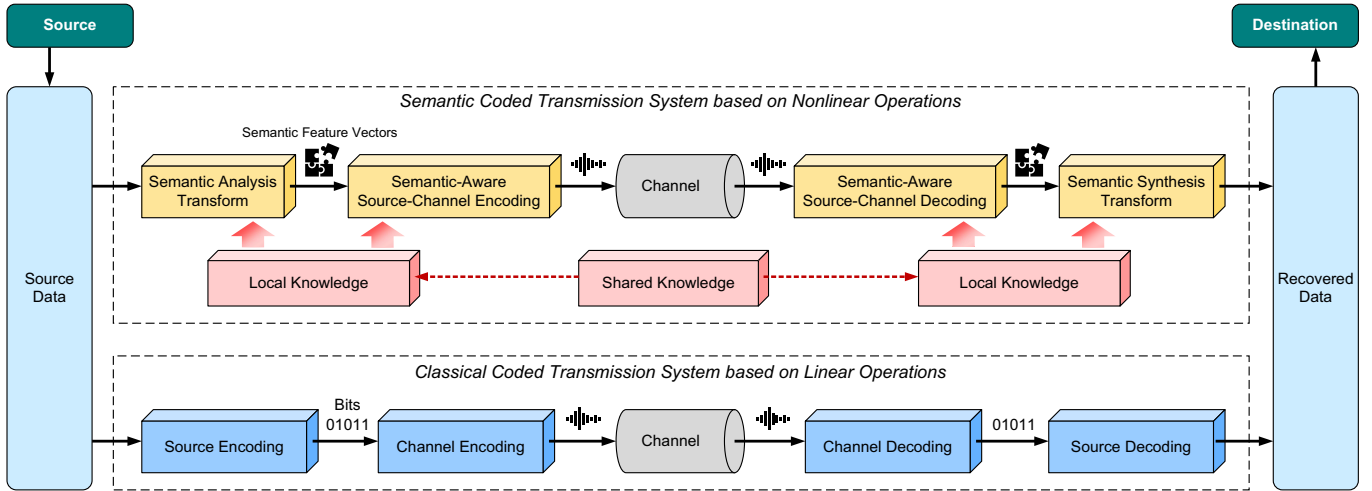

Fig. 1. Schematic diagram of a general semantic coded transmission (SCT) system.

development of today’s communication systems. Constrained by the historical context and technological development of the time, Shannon put aside the semantic problem and pointed out that the semantic aspects of communication are irrelevant to the engineering problem [1]. However, as Weaver and Brillouin respectively commented, this does not mean that the engineering problems are necessarily irrelevant to the semantic aspects, nor that these elements of human value will have to be ignored forever.

Nowadays, technical problems regarding effectiveness and reliability have been extensively solved, and the time that various objects communicate to convey desired semantic meanings has come. Meanwhile, fortunately, recent advances of semantic information processing techniques in natural language processing (NLP) and computer vision (CV) greatly allow us to integrate semantic aspects into communication systems to further improve the end-to-end transmission efficiency. Therefore, the whole system can upgrade to the Level B. Furthermore, as we shall note, different from human-type communications (HTC), in machine-type communications (MTC), the SCT system can directly process downstream tasks that indeed works on the Level C.

III. GENERAL ARCHITECTURE OF SCT

By an SCT system we will mean a system of the type indicated schematically in Fig. 1. It consists of essentially the following eight parts:

1. A *source* that produces data to be communicated to the receiving terminal. The source data may be of various types: (a) Text consisting of a sequence of letters; (b) Speech consisting of audio signals; (c) Image defined by three-dimensional multiplexed vectors; (d) Video realized by a series of correlated image frames in chronological order; (e) Various combinations above types, for example, multimedia data containing video and an associated audio channel.
2. A *semantic analysis transform* module that operates on the source data in some way to extract semantic features and produce semantically annotated messages. Different from

traditional transforms that mainly removes correlations in source data, here, the semantic analysis transform is carried out by nonlinear operations [4]. The resulting semantically annotated feature map is segmented as multiple semantic channels, each one contains a semantic feature vector (SFV) whose elements belong to the same semantic object.

3. A *source-channel encoder* that operates on every SFV in some way to produce signals suitable for transmission over the channel. This module is also included in classical communication systems while it differs from them in its semantic-aware ability. In particular, the source-channel encoder compresses and protects each SFV transmitted over the channel where the encoding scheme and coding rate are determined in accordance with the relative semantic importance of this SFV, this process is attributed as “semantic importance biased coding”. In addition, the compression (source coding) and error correction (channel coding) of this encoder can be realized either in a separated way as in traditional systems, or in a joint way that follows the joint source-channel coding theory [5].
4. The *channel* is merely the physical medium used to transmit the signal from transmitter to receiver, which is identical with that in the classical system.
5. The *source-channel decoder* performs the inverse operation of that done by the source-channel encoder, reconstructing the SFVs.
6. The *semantic synthesis transform* module also performs the inverse operation of that done by the semantic analysis transform. As we shall see, different from classical linear transforms, the semantic synthesis transform with nonlinear operations can exploit the two dimensional correlations, i.e., intra- and inter-semantic-channel correlations, to further correct residual errors in the SFV elements. This extra process is attributed as “semantic distortion correction”. After that, it performs semantic feature fusion to recover the source data or directly execute downstream tasks.
7. The *destination* is the person (or thing) for whom the source data is intended.
8. The *local knowledge* is implicitly given at both transmitter

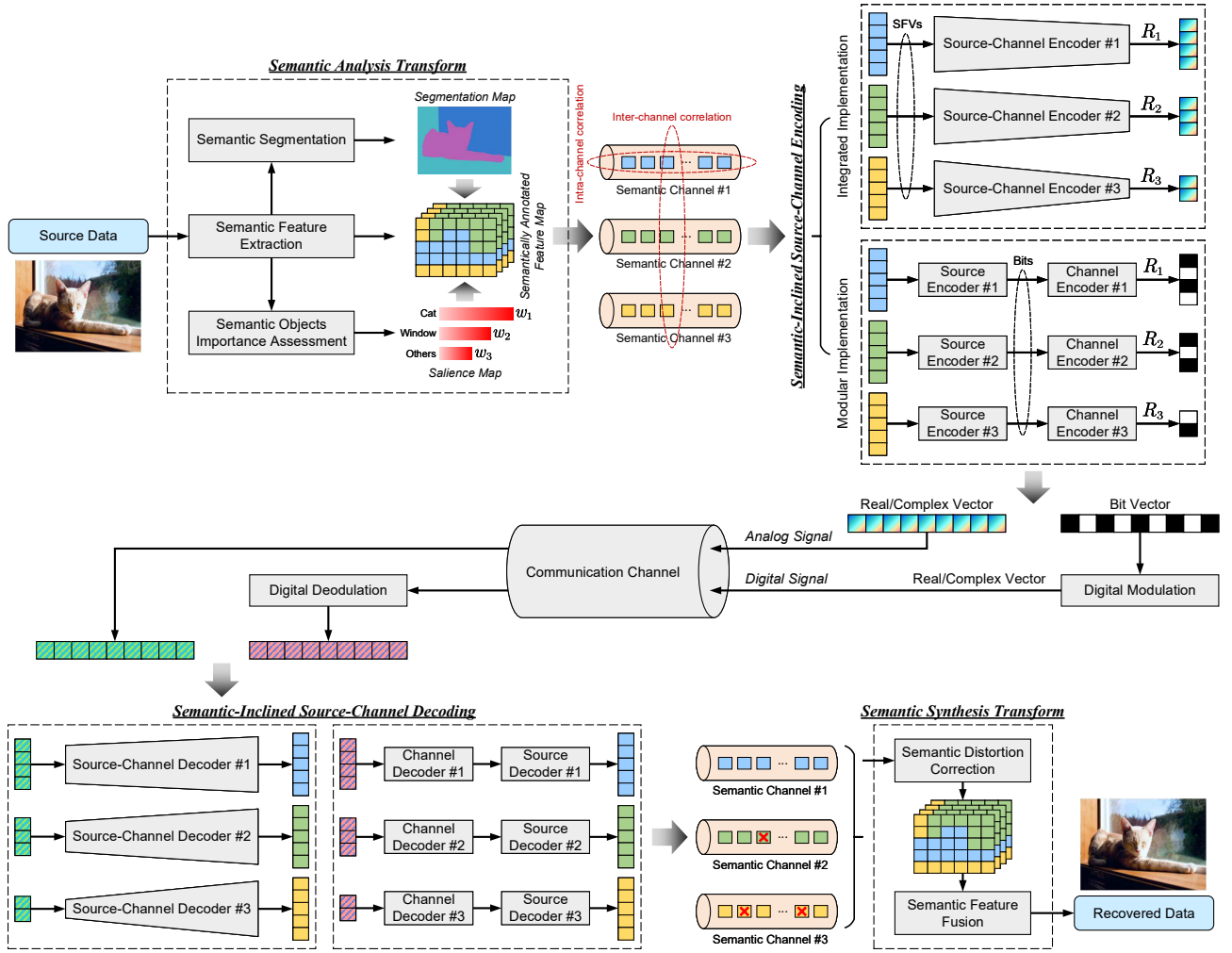

Fig. 2. The general architecture of a SCT system, includes common semantic transform and two practical source-channel coding implementations.

and receiver ends which provides *a priori* information. This module may be not necessarily an entity, for example, it can also be the dataset used for training the deep neural networks that are employed for semantic feature transform and source-channel coding such that the resulting network parameters indeed become one format of knowledge.

Motivated by the research route of Shannon theory, we also wish to consider certain general problems involving this SCT systems. To do this, the first step should represent the various elements involved as mathematical entities, suitably idealized from their physical counterparts. However, at the current stage, most semantic information processing methods rely heavily on deep learning techniques which are hard to be modeled as general mathematical entities. Thus, the exploration of mathematical theory of SCT will still be an open and challenging problem, which is beyond the scope of this article. Nevertheless, we can also tentatively explore available critical methodologies in SCT systems first.

IV. KEY METHODOLOGIES IN SCT SYSTEMS

A. Semantic Nonlinear Transforms

Semantic nonlinear transforms in SCT embrace the semantic analysis transform at the transmitter and the semantic synthesis

transform at the receiver.

To realize semantic coded transmission, the first step is the semantic extraction and representation of source data. This gives rise to the need of new semantic analysis transform module to extract the semantic feature of source data. Different from classical linear transforms, such as the Karhunen-Loève transform (KLT), which map the source vector into a latent space via a decorrelating invertible transform, the semantic analysis transform maps the source data to semantic latent space via nonlinear transform that closely matches and represents the source content [4].

Until a few years ago, one of the fundamental constraints in designing transform was that determining nonlinear transforms with desirable properties, such as identifying source content and improved correlation property between latent dimensions, is a difficult problem for high dimensional sources. However, this premise has changed with the recent resurgence of artificial neural networks (ANNs). With the right set of parameters, elaborate ANNs with nonlinear properties can approximate arbitrary source distributions and extract the source semantic features. In the SCT system, the ANN-based semantic analysis transform outputs the semantically annotated feature map in the latent space. Taking the image transmission in Fig. 2 as

an example, the semantic analysis transform module includes three functions as follows.

- (1) Semantic feature extraction: It maps the original source to its corresponding feature map at the latent space, which can be usually realized by convolutional neural networks (CNN), Transformer, etc. As we shall note, this feature map preserves the semantic information that can be used to reconstruct the source data.
- (2) Semantic segmentation: Using semantic segmentation networks acting on the feature map, it produces the segmentation map including multiple semantic objects. Combining it with the feature map, one gets the semantically annotated feature map.
- (3) Semantic objects importance assessment: it utilizes semantic objects obtained at the semantic segmentation step to assess their relative importance, in practice, this can be embodied as scores or importance rankings. The resulting salience map guides the following source-channel coding design.

After the semantic analysis transform, we indeed get multiple semantic channels in the latent space as depicted in Fig. 2, each one contains an SFV whose elements belong to the same semantic object. It is worth noting that two dimensional correlations exist among elements in semantic channels. The first one locates within every semantic channel representing the correlation of the elements in each SFV, which can be used to reconstruct its corresponding semantic object. The other one exists among semantic channels representing the correlation among different SFVs, which helps transforming multiple objects back to the whole source data.

The receiver in SCT invokes the semantic synthesis transform module to recover the source data or to execute downstream tasks directly. As shown in Fig. 2, the semantic synthesis transform module mainly involves two functions, semantic distortion correction and semantic feature fusion, which are also nonlinear transforms essentially. Considerable explanations of semantic distortion correction will be given later since it plays a significant role in enhancing the fidelity of transmitted data in SCT. As for semantic feature fusion, it actually performs the inverse operation of the transmitter utilizing the corrected feature map in the latent space, which comes from semantic distortion correction.

B. Semantic Inclined Coding

Semantic objects in transmitted source data usually vary in importance. For example, suppose our downstream task is face recognition or re-identification, then the objects that let us recognize persons are more important than that shows the image background. Therefore, we should adopt a biased coding strategy in line with different importance ranks. Recall the above example, we would be better allocate lower coding rate to the part describing the background and higher coding rate to protect the part that allows recognition of the face. Such a biased coding strategy needs to quantify the importance of different semantic objects of data and, as channel conditions deteriorate, discard the least important object while retaining the most important object. Techniques like salience detection

[6] can help us assess the semantic importance of each SFV in accordance with specific downstream tasks.

Motivated by this idea, following the semantic nonlinear transform, the second key technique in SCT is the semantic importance biased coding. It is conceptually like the “unequal error protection (UEP)” in classical forward error correction coding schemes [7]. However, here the biased coding involves both source and channel coding such that the specific coding scheme of each SFV is in the light of its semantic importance and will be transmitted over lossy wireless links without using feedback. Compared to this, traditional UEP only operates at channel coding without considering semantic aspects.

C. Semantic Distortion Correction

As aforementioned, two dimensional correlations existing within and among semantic channels can be used to correct semantic-level distortions of SFV elements. This operation is referred to as the third key technique in SCT, i.e., the semantic distortion correction, which can further correct the residual errors after source-channel decoding. As we shall see, compared to state-of-the-art coded transmission systems, this extra semantic-level distortion correction technique can further improve the end-to-end transmission quality, consequently, the number of automatic repeat requests (ARQ) can be reduced that finally contributes to higher link throughput.

Specifically, the semantic distortion correction technique can be realized with generative neural networks, e.g., generative adversarial network (GAN), that are of “creativity” by exploiting the semantic-level correlations to generate distortion parts in source content. This idea has been studied widely in NLP and CV communities, such as automatic post-editing [8], super-resolution [9], inpainting and denoising [10], style transfer [11], etc. Here, we introduce them into SCT system helping to improve the end-to-end transmission efficiency, which will become a key technique in future semantic communication systems.

V. PRACTICAL IMPLEMENTATIONS OF SCT

Practical implementations of SCT fall into two categories, depending on whether the signals transmitted over the communication channels are digital or analog. After the semantic analysis transform, the source-channel coding part can either resort to classical coding schemes combined with digital modulation to produce digital signals or adopt the emerging deep joint source-channel coding schemes operated by ANNs to produce analog signals directly. Following their implementation architecture, we briefly describe these two SCT implementations as modular and integrated designs, respectively.

A. Modular Implementation

As a compatible scheme with current digital communications systems (e.g., 4G and 5G), the modular implementation of SCT retains the channel coding and digital modulation modules to transmit digital signals.

In specific, consider an image source in Fig. 2, the parametric analysis transform module produces the semantically annotated feature map first. That is then divided into multiple SFVs,

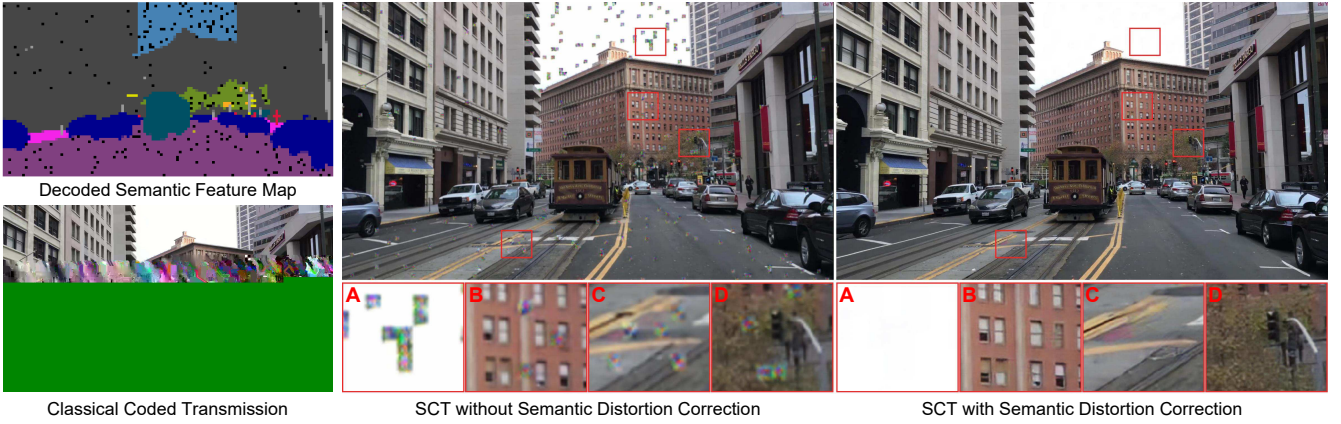

Fig. 3. A comparison of image transmission via two coded transmission schemes. The semantic distortion correction module applied in the modular SCT implementation can enhance the final quality of reconstruction by utilizing context and classification information.

each one corresponds to a semantic object. In the source-channel encoding step, each resulting SFV is first quantized and interleaved, then compressed by an entropy encoder into digit bits, and finally loaded into packages. Next, advanced channel coding (e.g., low-density parity-check (LDPC) or Polar coding) follows to protect the source-coded bits against channel interference and additive noise. The overall source-channel coding rate of each SFV is assigned according to its semantic importance based on the biased coding strategy.

In the receiving end, the digital demodulation operates on the received signal first, outputs the soft estimations of digit bits, which are sent to their corresponding channel decoder. The channel decoded messages are then fed to the source decoder to recover SFVs. A major disadvantage of this approach is that residual errors in channel decoded messages will incur severe error propagation in source decoding due to the use of entropy coding. However, in the SCT system, this undesirable phenomenon can be alleviated by the semantic distortion correction module. By generating the corrupt regions according to semantic description and context information, the end-to-end transmission quality can be improved.

Fig. 3 presents an example of modular implementation of SCT for image transmission. Here, a 2048 (height) \times 1024 (width) cityscapes image [12] is transmitted to the receiving end over the additive white Gaussian noise (AWGN) channel with the signal-to-noise ratio (SNR) 1dB. Among the various categories of semantic objects in the cityscapes, the humans, vehicles, and buildings are assessed to be of higher importance while other natural environments, e.g., the sky and trees, are of lower importance. For the classical coded transmission scheme, we plot the reconstructed image of the concatenation of BPG codec followed by LDPC channel coding. As we can see, it fails to reconstruct all regions due to the residual bit errors given by the channel decoder propagating among other coded bits. For the SCT scheme, the residual bit errors also lead to a corrupted semantic feature map (plotted in the left top, where the black pixels indicate the corrupted locations), and then cause the mosaics during the reconstruction process. However, the main difference between classical coded transmission and SCT is that the latter coded with biases to match the importance of SFVs. In this manner, errors tend to

cause corruption in SFVs with lower importance. Moreover, as shown in the right sub-figure, such corruptions can be further corrected using an inpainting model so that the whole image quality increases visibly.

B. Integrated Implementation

Following the joint source-channel coding idea, the source-channel coding part in the SCT system can also be designed as an integrated module, which does not rely on explicit codes for either compression or error correction; Instead, it maps the SFVs to the channel input symbols directly. We can parameterize the encoder and decoder functions by two jointly trained ANNs. They together constitute an autoencoder affected by a non-trainable layer that represents the noisy communication channel [13]. The joint coding rate of each SFV should be aligned with their semantic importance. Moreover, the ANN-based source-channel coding allows gradients propagating between coding modules and semantic nonlinear transform modules. Therefore, this integrated implementation manner can realize the end-to-end learning to minimize the perceptual loss or handle the downstream tasks directly. The whole procedure is also depicted in Fig. 2.

According to the two types of communication scenarios, i.e., HTC and MTC, we exemplify some SCT performance results based on integrated implementation and analog transmitted signals.

1) *SCT in HTC Scenario*: Consider a typical HTC scenario where images are transmitted over wireless links to meet human browsing requirements. To quantify the effectiveness of SCT, we adopt both the widely used peak signal-to-noise ratio (PSNR) metric and the emerging learned perceptual image patch similarity (LPIPS) metric [14]. Compared to PSNR, LPIPS accounts for more image nuances of human perception.

In this case, each image is segmented into a visually attractive object and its background object through a saliency detection model [6], which are labeled as semantic objects I and II, respectively. Clearly, object I is annotated with higher importance. In practice, network parameters are optimized to minimize an importance-score weighted distortion between the input image and the recovered version over training images,

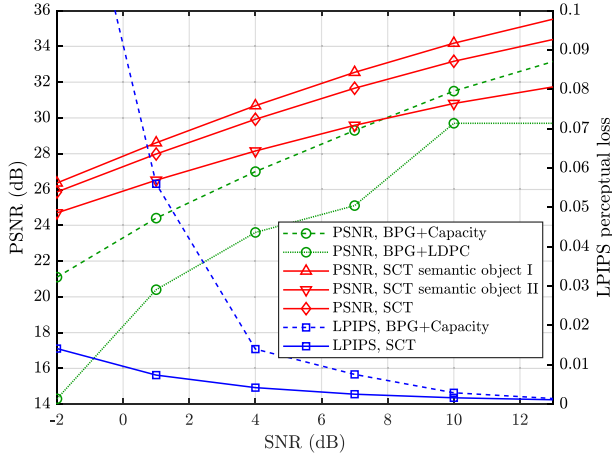

Fig. 4. Reconstruction quality comparison between classical coded transmission and SCT in CIFAR10 dataset.

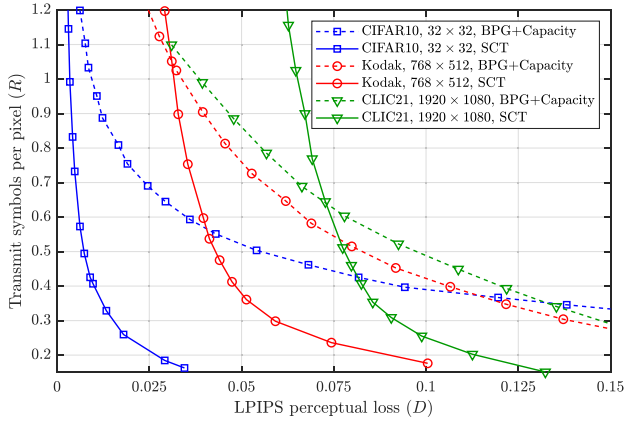

Fig. 5. Perceptual quality comparison at the AWGN channel (SNR = 1dB), where three datasets with different resolutions are adopted.

and evaluations are taken over another completely distinct validation image set.

Fig. 4 demonstrates the simulation results of the distortion of the recovered image versus a range of SNR values over the AWGN channel. Different schemes transmit input images with a fixed bandwidth ratio $R = 1/6$, i.e., the number of transmit symbols is $1/6$ of the image dimension. To compare with the separation-based communication system, we use a powerful image compressor (BPG codec) combined with a widely used channel coded modulation scheme (LDPC and QAM), which has the state-of-the-art performance of practical separation-based image transmission schemes. Besides, we also provide the performance of BPG equipped with the capacity-achieving code family to serve as an upper bound of the separated coding scheme. Due to the powerful nonlinear semantic transform and joint source-channel optimization, integrated SCT outperforms “BPG+LDPC” and “BPG+Capacity” in terms of two quality metrics, especially in the low SNR region. Moreover, object I is transmitted with less distortion than its background, so the perceptual metric of the whole image in terms of LPIPS shows a clear improvement compared to the ideal “BPG+Capacity”, which verifies the effectiveness of the semantic importance biased coding method.

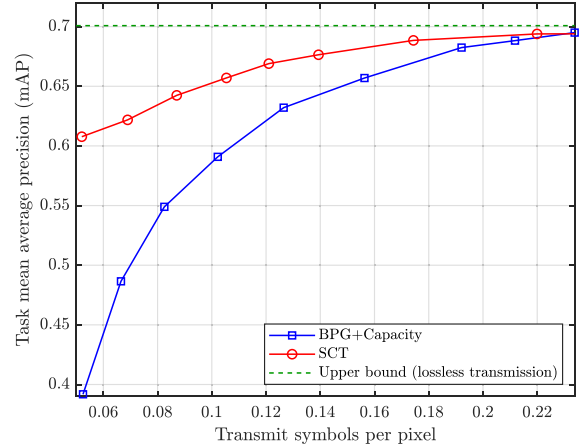

Fig. 6. Downstream task performance comparison at the AWGN channel (SNR = 1dB).

Fig. 5 presents the quantitative comparison of the LPIPS perceptual loss versus a range of bandwidth ratio R (defined as the number of transmitted symbols per pixel) over three widely used datasets with different resolutions. We can find that integrated SCT surpasses the classical coded transmission, especially in the low rate region ($R < 0.6$). However, the latter performs better in high-resolution images due to the highly optimized source codes and ideal channel codes. Even so, as an emerging scheme, SCT has shown its potential in this case and can be further improved by using more advanced ANN architectures and more elaborate designs.

2) *SCT in MTC Scenario*: For an MTC scenario, a wireless re-identification (ReID) problem is studied [15]. The wireless camera takes a query picture of a pedestrian and encodes it locally before sending it to the central server through a wireless channel. The central server is supposed to identify the query identity on a large database called gallery. To maximize the precision performance of ReID task, an intuitive solution would transmit the whole query picture at the best quality and utilize it as the input of ReID network. In fact, a large part of the image content may not be relevant to the ReID task. As an alternative, wireless cameras using the SCT scheme learn only to transmit the valuable SFVs, i.e., the human category in this case. Then, the central server identifies the queries from noisy SFVs, and the whole scheme is trained directly for the end-to-end ReID task. In this case, we use a pre-trained ResNet-50 network to identify queries transmitted over an AWGN channel with a fixed SNR of 1dB. The mean average precision is calculated to measure the downstream task performance. All experiments are taken from the CUHK03 dataset [15]. Results in Fig. 6 show that both schemes can approach the performance using lossless query at high rate region, but in the low rate region, the SCT scheme outperforms the “BPG+Capacity” with a clear gap.

In both above cases, we observe that the SCT ensures the communication terminals to process semantic-annotated messages in a high-effectiveness manner. Note that this promotion comes from a content-aware mechanism that can be further generalized to all types of downstream tasks.

VI. CHALLENGES AND RESEARCH OPPORTUNITIES

A. Theoretical Challenges

In contrast to the classical methods of coded transmission under the umbrella of Shannon's information theory, the SCT methods based on deep learning lack solid mathematical foundations in terms of theoretical analysis. This however is desired to guide the practical design of SCT and provide insights into their performance limits. Provided that the training data obeys a certain distribution, the principle of typical sequence in Shannon information theory may still contribute to the theoretical basis of SCT. Furthermore, the Kolmogorov complexity may be used to analyze the tradeoff function between the channel transmission rate and the end-to-end semantic distortion, i.e., the semantic-level $R(D)$ function.

B. Methodology-Related Challenges

The amount and quality of training data are essential for the final performance of SCT. However, acquiring sufficiently high-quality data for training in SCT is not as straightforward as that in pure data-related applications. On the one hand, the training data includes not only the source semantic feature but also the wireless channel feature. In this case, how to generate a large amount of data remains a challenge. On the other hand, different data sets used for training and testing may result in different performance. To ensure a fair comparison, how to build widely accepted semantic-annotated data for various communication scenarios is still challenging. In particular, the aforementioned semantic object segmentation and importance assessment steps are highly related to the downstream task, thus the SCT works in an intend-driven mode that needs to be elaborated for each communication scenario.

C. Implementation-Related Challenges

Deploying SCT methods in real communication systems will face implementation-oriented challenges. Since the classic communication methodologies may not be completely replaced by the SCT techniques in a short time, a soft switching scheme is needed to switch between the SCT methods and the non SCT methods. We may need a new architecture to support the harmonious co-existence of SCT and classical coded transmission methods. Especially, the aforementioned integrated implementation scheme of SCT produces analog signal that is not compatible with current digital communication systems, this may need a redesign of the signal format transmitted over wireless channels.

VII. CONCLUSIONS

In this article, we have introduced a new concept of semantic coded transmission (SCT), where the transmitted content meaning and downstream tasks have been explicitly taken into account for boosting the optimization of coded transmission system. In particular, we have presented the SCT architecture, key methodologies, implementation schemes, and performance gains. Also, we have pointed out some challenges and research opportunities in this emerging area. In summary, SCT will be the fundamental of semantic communications, we believe the

further study of SCT can promote the development of semantic communications in both theory and algorithm aspects.

REFERENCES

- [1] C. E. Shannon, "A mathematical theory of communication," *The Bell System Technical Journal*, vol. 27, no. 3, pp. 379–423, 1948.
- [2] P. Zhang, J. Zhang, Q. Qi, Z. Hu, G. Nie, K. Niu, and H. Tian, "Ubiquitous-x: Constructing the future 6G networks," *SCIENTIA SINICA Informationis*, vol. 50, no. 6, pp. 913–930, 2020.
- [3] W. Weaver, "Recent contributions to the mathematical theory of communication," *ETC: A Review of General Semantics*, pp. 261–281, 1953.
- [4] J. Ballé, P. A. Chou, D. Minnen, S. Singh, N. Johnston, E. Agustsson, S. J. Hwang, and G. Toderici, "Nonlinear transform coding," *IEEE Journal of Selected Topics in Signal Processing*, vol. 15, no. 2, pp. 339–353, 2020.
- [5] M. Fresia, F. Perez-Cruz, H. V. Poor, and S. Verdú, "Joint source and channel coding," *IEEE Signal Processing Magazine*, vol. 27, no. 6, pp. 104–113, 2010.
- [6] X. Qin, Z. Zhang, C. Huang, M. Dehghan, O. R. Zaiane, and M. Jagersand, "U2-net: Going deeper with nested U-structure for salient object detection," *Pattern Recognition*, vol. 106, p. 107404, 2020.
- [7] A. E. Mohr, E. A. Riskin, and R. E. Ladner, "Unequal loss protection: Graceful degradation of image quality over packet erasure channels through forward error correction," *IEEE Journal on Selected Areas in Communications*, vol. 18, no. 6, pp. 819–828, 2000.
- [8] S. Pal, S. K. Naskar, M. Vela, and J. van Genabith, "A neural network based approach to automatic post-editing," in *Proceedings of the 54th Annual Meeting of the Association for Computational Linguistics (Volume 2: Short Papers)*, 2016, pp. 281–286.
- [9] C. Dong, C. C. Loy, K. He, and X. Tang, "Learning a deep convolutional network for image super-resolution," in *European Conference on Computer Vision*. Springer, 2014, pp. 184–199.
- [10] R. A. Yeh, C. Chen, T. Y. Lim, A. G. Schwing, M. Hasegawa-Johnson, and M. N. Do, "Semantic image inpainting with deep generative models," in *Proceedings of the IEEE Conference on Computer Vision and Pattern Recognition*, 2017, pp. 5485–5493.
- [11] P. Isola, J. Zhu, T. Zhou, and A. A. Efros, "Image-to-image translation with conditional adversarial networks," in *Proceedings of the IEEE Conference on Computer Vision and Pattern Recognition*, 2017, pp. 1125–1134.
- [12] M. Cordts, M. Omran, S. Ramos, T. Rehfeld, M. Enzweiler, R. Benenson, U. Franke, S. Roth, and B. Schiele, "The cityscapes dataset for semantic urban scene understanding," in *Proceedings of the IEEE Conference on Computer Vision and Pattern Recognition*, 2016, pp. 3213–3223.
- [13] E. Boursoulatzé, D. B. Kurka, and D. Gündüz, "Deep joint source-channel coding for wireless image transmission," *IEEE Transactions on Cognitive Communications and Networking*, vol. 5, no. 3, pp. 567–579, 2019.
- [14] R. Zhang, P. Isola, A. A. Efros, E. Shechtman, and O. Wang, "The unreasonable effectiveness of deep features as a perceptual metric," in *Proceedings of the IEEE Conference on Computer Vision and Pattern Recognition*, 2018, pp. 586–595.
- [15] E. Ahmed, M. Jones, and T. K. Marks, "An improved deep learning architecture for person re-identification," in *Proceedings of the IEEE Conference on Computer Vision and Pattern Recognition*, 2015, pp. 3908–3916.