

CYCLEFLOW: PURIFY INFORMATION FACTORS BY CYCLE LOSS

Haoran Sun, Chen Chen, Lantian Li*, Dong Wang*

Center for Speech and Language Technologies, BNRist, Tsinghua University, China
Department of Computer Science and Technology, Tsinghua University, China

ABSTRACT

SpeechFlow is a powerful factorization model based on information bottleneck (IB), and its effectiveness has been reported by several studies. A potential problem of SpeechFlow, however, is that if the IB channels are not well designed, the resultant factors cannot be well disentangled. In this study, we propose a CycleFlow model that combines random factor substitution and cycle loss to solve this problem. Experiments on voice conversion tasks demonstrate that this simple technique can effectively reduce mutual information among individual factors, and produce clearly better conversion than the IB-based SpeechFlow. CycleFlow can also be used as a powerful tool for speech editing. We demonstrate this usage by an emotion perception experiment.

Index Terms— speech information factorization, SpeechFlow, cycle loss, random factor substitution

1. INTRODUCTION

A distinct talent of human beings is that we can decompose the information load within speech signals accurately and effectively [1, 2]. Researchers have made quite some attempts to simulate this ability and presented a couple of information factorization models to decompose speech [3, 4, 5, 6].

Most of the current speech factorization models are based on deep neural nets. Early research employed supervision from several tasks and used it to factorize speech information in a cascade way [7]. Later research mostly focused on unsupervised learning. For example, Hsu et al. [8, 9] tried to establish statistical models in the latent space and factorize speech signals according to the different statistical properties of the target factors.

Recently, Qian et al. [10, 11] presented a factorization model based on information bottleneck (IB) [12], and reported good performance in voice conversion (VC) tasks. The basic idea behind the IB-based approach is that by designing appropriate IB channels, one can control the type and amount of the information flow. AutoVC is the first successful IB-based VC model [10]. The architecture is a conditional autoencoder (AE) where speaker identity is used as condition. As the speaker information has been known by the model, the latent code only represents the content,

leading to speaker-content decomposition. SpeechFlow is an extension of AutoVC and represents more factorization capability [11]. Using carefully designed IB channels, the model can factorize speech signals into fine-grained factors, including timbre, rhythm, pitch and content.

In spite of the promising results, the design of the IB channels is difficult within SpeechFlow, and an improper setting (e.g., dimension of factors or the resampling scheme) inevitably leads unsatisfied factorization. Unfortunately, discovering an optimal setting for the model is often a difficult task. This problem has been noticed by the original authors and some other researchers [13, 14].

In this study, we present a novel model CycleFlow to purify the information factors. The main design is a random factor substitution (RFS) operation and a cycle loss. We highlight that this technique is simple and general and can be applied to any factorization model, although in this study we test it with the SpeechFlow architecture, hence the name CycleFlow. We show theoretically and empirically that the new design indeed produces more disentangled factors. Moreover, CycleFlow can be used as a powerful tool for speech editing, hence useful for broad research fields. We demonstrate the usage by an emotion perception experiment.

2. METHOD

In this section, we revisit the SpeechFlow model presented in [11], then propose our contribution. The entire architecture is illustrated in Fig. 1.

2.1. Revisit SpeechFlow

SpeechFlow decomposes speech signals into four separate informational factors: rhythm Z_r , pitch Z_f , content Z_c and timbre Z_t by four encoders:

$$\begin{aligned} Z_r &= E_r(S), \\ Z_f &= E_f(RR(P)), \\ Z_c &= E_c(RR(S)), \\ Z_t &= E_t(S), \end{aligned}$$

where RR denotes *random resampling* that will be explained below. Note that the input of the pitch encoder is pitch contour

P , rather than speech S .

The training objective of the model is to reconstruct the original speech S from these information factors:

$$\mathcal{L}_{rec} = \|\hat{S} - S\|^2, \quad (1)$$

where $\|\cdot\|$ denotes the ℓ_2 -norm. \hat{S} is the reconstructed speech, which is obtained by a decoding process:

$$\hat{S} = D(\mathbf{Z}_r, \mathbf{Z}_f, \mathbf{Z}_c, \mathbf{Z}_t). \quad (2)$$

To ensure that the information factors hold their desired information after model training, the encoders need some special designs, motivated by the IB theory. The first design choice is to select appropriate dimensions for the four factors so as to ensure minimum sufficient capacity. Secondly, the timbre factor is specified (not need to learn) by a deep speaker vector [15]. Thirdly, a random resampling operation (RR) shrinks or stretches the duration of the inputs to the pitch and content encoders in order to prevent them from learning rhythm information. With these designs, different information tend to be captured by different factors, as shown in [11].

2.2. Our proposed CycleFlow

Although the design of SpeechFlow is exquisite, in practice, there is no guarantee that the encoders extract disentangled factors. This is because the IB channels, i.e., the dimensions of the information factors are difficult to choose, and the resampling process is also not easy to control. As we will show in Section 4, high mutual information (MI) often exists between the factors produced by SpeechFlow.

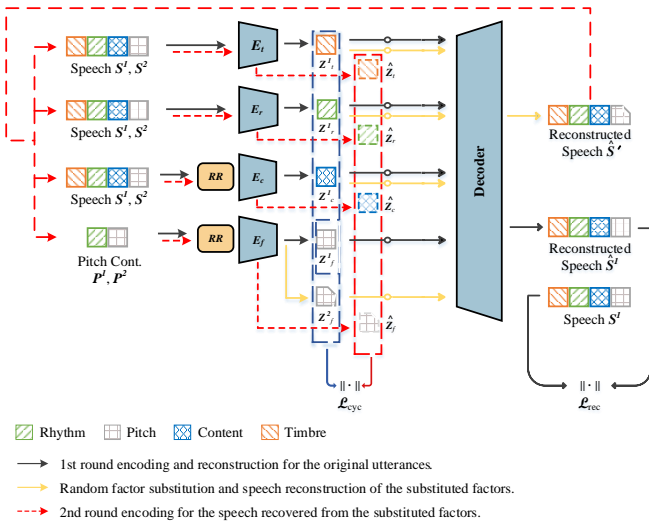

Fig. 1. The architecture of CycleFlow.

CycleFlow is proposed to purify the information factors by introducing a cycle loss. The idea of cycle loss is motivated by CycleGAN [16], but here we combine the cycle loss

with a factor substitution in order to encourage information disentanglement. The new design is shown as yellow solid lines, red dash lines and blocks in Fig. 1.

To make the presentation clear, we use two utterances, denoted by S^1 and S^2 , to demonstrate the computing process as follows.

- **1st round encoding:** Firstly encode S^1 and S^2 , resulting in two sets of factors: $\mathbf{Z}^1 = \{\mathbf{Z}_r^1, \mathbf{Z}_f^1, \mathbf{Z}_c^1, \mathbf{Z}_t^1\}$ and $\mathbf{Z}^2 = \{\mathbf{Z}_r^2, \mathbf{Z}_f^2, \mathbf{Z}_c^2, \mathbf{Z}_t^2\}$.
- **Random factor substitution (RFS):** Randomly choose a factor from \mathbf{Z}^2 , and use it to replace the corresponding factor in \mathbf{Z}^1 . Suppose that the selected factor is \mathbf{Z}_f^2 , we get a new factor set $\mathbf{Z}' = \{\mathbf{Z}_r^1, \mathbf{Z}_f^2, \mathbf{Z}_c^1, \mathbf{Z}_t^1\}$.
- **Speech reconstruction:** Forward \mathbf{Z}' to the decoder and produce the reconstructed speech \hat{S}' .
- **2nd round encoding:** Encode \hat{S}' and obtain $\hat{\mathbf{Z}}' = \{\hat{\mathbf{Z}}_r', \hat{\mathbf{Z}}_f', \hat{\mathbf{Z}}_c', \hat{\mathbf{Z}}_t'\}$.
- **Cycle loss computation:** The cycle loss is computed as follows:

$$\mathcal{L}_{cyc} = \|\mathbf{Z}' - \hat{\mathbf{Z}}'\|^2. \quad (3)$$

The final loss combines the reconstruction loss shown in Eq.(1) and the cycle loss shown in Eq.(3):

$$\mathcal{L} = \mathcal{L}_{rec} + \alpha * \mathcal{L}_{cyc}, \quad (4)$$

where α is a hyperparameter and is empirically set to be 5.0 in our experiments.

2.3. Theoretical analysis on CycleFlow

We show that under some moderate conditions, the cycle loss combined with RFS theoretically improves information disentanglement.

Let's define $\mathbf{Z}' = \{\mathbf{Z}'_1, \mathbf{Z}'_2\}$ the factors after RFS. Now reconstruct $\hat{\mathbf{X}}'$ from \mathbf{Z}' and conduct the 2nd round encoding to get $\hat{\mathbf{Z}}' = \{\hat{\mathbf{Z}}'_1, \hat{\mathbf{Z}}'_2\}$. Our purpose is to let $\hat{\mathbf{Z}}'_1$ fully determined by \mathbf{Z}'_1 and $\hat{\mathbf{Z}}'_2$ fully determined by \mathbf{Z}'_2 . This can be obtained by minimizing the conditional entropy $H(\hat{\mathbf{Z}}'_1|\mathbf{Z}'_1)$ and $H(\hat{\mathbf{Z}}'_2|\mathbf{Z}'_2)$, formulated by the following objective:

$$\begin{aligned} \mathcal{L}_{ch} &= H(\hat{\mathbf{Z}}'_1|\mathbf{Z}'_1) + H(\hat{\mathbf{Z}}'_2|\mathbf{Z}'_2) \\ &= -\mathbb{E}_{\mathbf{Z}'_1} \mathbb{E}_{\mathbf{Z}'_2} \log p(\hat{\mathbf{Z}}'_1|\mathbf{Z}'_1) - \mathbb{E}_{\mathbf{Z}'_2} \mathbb{E}_{\mathbf{Z}'_1} \log p(\hat{\mathbf{Z}}'_2|\mathbf{Z}'_2), \end{aligned}$$

where the inner expectation specifies the source of the conditional variation. If we further assume that the conditional probabilities $p(\hat{\mathbf{Z}}'_1|\mathbf{Z}'_1)$ and $p(\hat{\mathbf{Z}}'_2|\mathbf{Z}'_2)$ are isotropic Gaussian with variation σ , then we have:

$$\mathcal{L}_{ch} = \mathbb{E}_{\mathbf{Z}'_1} \mathbb{E}_{\mathbf{Z}'_2} \|\hat{\mathbf{Z}}'_1 - \mathbf{Z}'_1\|_2^2 + \mathbb{E}_{\mathbf{Z}'_2} \mathbb{E}_{\mathbf{Z}'_1} \|\hat{\mathbf{Z}}'_2 - \mathbf{Z}'_2\|_2^2 + C(\sigma) \\ \propto \mathbb{E}_{\mathbf{Z}'} \|\hat{\mathbf{Z}}' - \mathbf{Z}'\|_2^2,$$

where $C(\sigma)$ is a constant depending on σ . This is just the cycle loss shown in Eq.(3).

Further notice that \mathbf{Z}'_1 and \mathbf{Z}'_2 are independent, and in the case $\mathcal{L}_{ch} = 0$, $\hat{\mathbf{Z}}'_1$ is totally dependent on \mathbf{Z}'_1 , and $\hat{\mathbf{Z}}'_2$ is totally dependent on \mathbf{Z}'_2 , we have:

$$p(\hat{\mathbf{Z}}'_1 | \hat{\mathbf{Z}}'_2) = \int_{\mathbf{Z}'_1, \mathbf{Z}'_2} p(\hat{\mathbf{Z}}'_1 | \mathbf{Z}'_1, \mathbf{Z}'_2, \hat{\mathbf{Z}}'_2) p(\mathbf{Z}'_1, \mathbf{Z}'_2 | \hat{\mathbf{Z}}'_2) \\ = \int_{\mathbf{Z}'_1, \mathbf{Z}'_2} p(\hat{\mathbf{Z}}'_1 | \mathbf{Z}'_1) \frac{p(\hat{\mathbf{Z}}'_2 | \mathbf{Z}'_1, \mathbf{Z}'_2) p(\mathbf{Z}'_1) p(\mathbf{Z}'_2)}{p(\hat{\mathbf{Z}}'_2)} \\ = \int_{\mathbf{Z}'_1} p(\hat{\mathbf{Z}}'_1 | \mathbf{Z}'_1) \int_{\mathbf{Z}'_2} \frac{p(\hat{\mathbf{Z}}'_2 | \mathbf{Z}'_2) p(\mathbf{Z}'_2)}{p(\hat{\mathbf{Z}}'_2)} \\ = p(\hat{\mathbf{Z}}'_1).$$

This result means that if the model has been well trained and the cycle loss converges to zero, then the factors are mutually independent. Note that our derivation does not rely any IB design, hence equally applicable to IB-free models.

We highlight that the above result does not imply that real speech signals will be factorized in a disentangled way, as the reconstructed speech from the RFS factors, which is indeed decomposed into disentangled factors by the 2nd round encoding, does not necessarily represent real speech. However, we can enforce the representation by (1) Use factors produced from real speech to perform RFS; (2) Combine the cycle loss and the reconstruction loss. The training process presented in the previous section reflects these theoretical concerns.

3. RELATED WORKS

Cycle loss in this paper was motivated by the cycle consistency loss in CycleGAN [16]. The cycle loss has been proved to be useful in domain adaptation [17], image-to-image translation [18], medical image synthesis [19] and voice conversion [20]. We borrowed the idea from these studies and combined it with RFS to improve information disentanglement in speech factorization models. We also noticed that some authors employed adversarial training to pursue the same goal [13], but adversarial training is notoriously unstable and the computation cost is significant.

4. EXPERIMENTS

We tested the proposed CycleFlow on some quantitative and qualitative experiments. In voice conversion tasks, we tried to convert speaking style, speaking timber, and both. The source code and audio samples are available at <http://cycleflow.csl.t.org>.

4.1. Data and configurations

The corpus used to implement our experiments is the CSTR VCTK corpus [21]. Speech signals from 100 speakers were used to conduct model training, and those from 8 speakers were used to perform testing. The speakers and utterances in the training and test sets are not overlapped. All the speech signals were uniformly formatted to 16kHz, 16-bits, and then were transformed to spectrograms no longer than 192 frames by a short time Fourier transform (STFT).

SpeechFlow was implemented using the source code published online¹, and the same code was adapted to implement CycleFlow. We mostly followed the settings in the original repository, including network structure, data processing steps, and training scheme. The only major modification was that we changed the input to the timber encoder from one-hot speaker codes to continuous speaker vectors [15] in order to improve generalization capability.

4.2. Mutual information

In the first experiment, we investigate the mutual information (1) between the original speech and the encoded factors, and (2) between pairs of factors. Ideally, if the reconstruction loss is comparable (which is the case in our experiments), we hope all these mutual information is as low as possible.

A difficulty is that all the concerned variables are continuous and their dimensions are different. To tackle the problem, we firstly clustered each variable into 10 classes by K-means clustering, and then calculated mutual information based on the cluster IDs of the variables.

The results are shown in Table 1. It can be observed that in all the comparisons, CycleFlow achieves less mutual information. For rows 1, 2 and 3, this means that all the encoders eliminate more irrelevant information from the original speech. For row 4, 5 and 6, this represents that the factors are more independent. All these results demonstrate that CycleFlow can produce more disentangled factors.

Table 1. Mutual information between signals and factors, and factor pairs. S denotes the original speech signal. Z_c, Z_r, Z_f denote content, rhythm and pitch factors.

No.	Factors	SpeechFlow	CycleFlow
1	S vs. Z_c	0.5093	0.3659
2	S vs. Z_r	0.7133	0.6155
3	S vs. Z_f	0.5515	0.4312
4	Z_c vs. Z_r	0.5155	0.3400
5	Z_c vs. Z_f	0.4455	0.2983
6	Z_r vs. Z_f	0.5287	0.4953

¹<https://github.com/FantSun/Speechflow>.

4.3. Voice conversion

In the second experiment, we conducted voice conversion using SpeechFlow and CycleFlow. We hired 15 Chinese listeners, each being assigned 70 utterances in total, divided into 4 test groups: (1) reconstruction quality; (2) speaking style transfer; (3) timbre maintenance in style transfer; (4) speaker conversion with both style and timbre transfer. For each evaluation, we presented listeners two utterances produced by SpeechFlow and CycleFlow respectively, and asked them to select which one is better according to the specified quality metric.

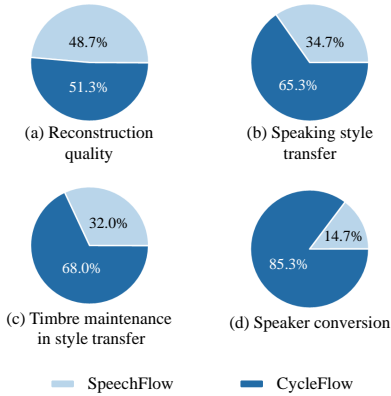

Fig. 2. Results of subjective evaluations.

Fig. 2 (a) shows the result of the reconstruction quality test, where listeners were required to select the reconstructed speech that sounded more similar to the original one and with better quality. The result shows that CycleFlow can produce reconstructed speech with comparable quality as SpeechFlow.

Fig. 2 (b) shows the result of speaking style transfer, where the speaking style (including both rhythm and pitch) of the source speech was changed to that of the target speech. The listeners were asked to select which utterance gave a better transfer. The result shows that CycleFlow is significantly better than SpeechFlow.

Fig. 2 (c) shows the result if the speaker timbre was maintained when the speaking style was transferred. The experiment is the same as in Fig. 2 (b), except that the listeners were asked to focus on timbre rather than speaking style. The result shows that CycleFlow clearly wins, and indicates that it maintains timbre better when speaking style is changed.

Fig. 2 (d) shows the result of speaker conversion, where both speaking style and timbre was changed. The listeners were asked to select which utterance performed a better conversion in terms of speaker similarity. Again, CycleFlow shows clear advantage.

As a summary, we demonstrated better independence of speaking style in (b) and (c), and the success of (d) further demonstrated better independence of speaker timbre. Overall, this experiment demonstrated that more independence was

obtained for all the factors by our proposed CycleFlow model: style (including pitch and rhythm), speaker timbre and content. Note that we did not intend to test pitch and rhythm separately, as it seems not easy for human listeners to identify them individually.

4.4. Human emotion perception

CycleFlow can be used as a speech editing tool. In this experiment, we demonstrate the usage using an emotion perception task, which aims to test if human ears can discriminate different types of emotion by using only cues of rhythm and pitch.

To achieve that goal, we first used CycleFlow to factorize speech signals and then set the content and timbre factor to be constant, and reconstructed the speech. By this operation, only speaking style (including pitch and rhythm) was retained. We then hired 8 listeners to identify the emotion of utterances in four emotion types: *Angry*, *Happy*, *Neutral*, *Sad*. 97 utterances from IEMOCAP [22] were used in the test. The pair-wised accuracy is shown in Fig. 3. As can be seen, only with speaking style, human can tell the emotion of a speech with a good accuracy. In particular, we seem more excel at identifying angry and sad emotion. This coincides with our daily experience.

Note that this experiment should not be regarded as a strict scientific study, but a simple demo of usage. Moreover, CycleFlow is more suitable than SpeechFlow in this usage, as it can decompose speech signals into more disentangled factors.



Fig. 3. Pair-wised accuracy of human emotion perception test with only rhythm and pitch cues.

5. CONCLUSION

We proposed a novel CycleFlow model for speech information factorization. The core of the design is a combination of factor substitution and cycle loss. We demonstrated theoretically and empirically that the proposed technique can significantly reduce mutual information among factors, and produce better performance in voice conversion. Moreover, CycleFlow can be used as a powerful tool for speech editing, hence lending itself to a wide range of scientific research. Future work involves applying cycle loss to other factorization models, and using it to design more detailed factorization.

6. REFERENCES

- [1] Terence W Picton, Steven A Hillyard, Robert Galambos, and Maurice Schiff, “Human auditory attention: a central or peripheral process?,” *Science*, vol. 173, no. 3994, pp. 351–353, 1971.
- [2] Lynne A Werner and G Cameron Marean, *Human auditory development*, Routledge, 2019.
- [3] Marc D Pell, Abhishek Jaywant, Laura Monetta, and Sonja A Kotz, “Emotional speech processing: Disentangling the effects of prosody and semantic cues,” *Cognition & Emotion*, vol. 25, no. 5, pp. 834–853, 2011.
- [4] Slava Shechtman and Alex Sorin, “Sequence to sequence neural speech synthesis with prosody modification capabilities,” *arXiv preprint arXiv:1909.10302*, 2019.
- [5] Ju-chieh Chou, Cheng-chieh Yeh, Hung-yi Lee, and Lin-shan Lee, “Multi-target voice conversion without parallel data by adversarially learning disentangled audio representations,” *arXiv preprint arXiv:1804.02812*, 2018.
- [6] Ju-chieh Chou, Cheng-chieh Yeh, and Hung-yi Lee, “One-shot voice conversion by separating speaker and content representations with instance normalization,” *arXiv preprint arXiv:1904.05742*, 2019.
- [7] Lantian Li, Dong Wang, Yixiang Chen, Ying Shi, Zhiyuan Tang, and Thomas Fang Zheng, “Deep factorization for speech signal,” in *ICASSP*. IEEE, 2018, pp. 5094–5098.
- [8] Wei-Ning Hsu, Yu Zhang, and James Glass, “Unsupervised learning of disentangled and interpretable representations from sequential data,” *arXiv preprint arXiv:1709.07902*, 2017.
- [9] Wei-Ning Hsu, Yu Zhang, Ron J Weiss, Heiga Zen, Yonghui Wu, Yuxuan Wang, Yuan Cao, Ye Jia, Zhifeng Chen, Jonathan Shen, et al., “Hierarchical generative modeling for controllable speech synthesis,” *arXiv preprint arXiv:1810.07217*, 2018.
- [10] Kaizhi Qian, Yang Zhang, Shiyu Chang, Xuesong Yang, and Mark Hasegawa-Johnson, “Autovc: Zero-shot voice style transfer with only autoencoder loss,” in *ICML*. PMLR, 2019, pp. 5210–5219.
- [11] Kaizhi Qian, Yang Zhang, Shiyu Chang, Mark Hasegawa-Johnson, and David Cox, “Unsupervised speech decomposition via triple information bottleneck,” in *ICML*. PMLR, 2020, pp. 7836–7846.
- [12] Naftali Tishby, Fernando C Pereira, and William Bialek, “The information bottleneck method,” *arXiv preprint physics/0004057*, 2000.
- [13] Jie Wang, Jingbei Li, Xintao Zhao, Zhiyong Wu, and Helen Meng, “Adversarially learning disentangled speech representations for robust multi-factor voice conversion,” *arXiv preprint arXiv:2102.00184*, 2021.
- [14] Kaizhi Qian, Yang Zhang, Shiyu Chang, Jinjun Xiong, Chuang Gan, David Cox, and Mark Hasegawa-Johnson, “Global rhythm style transfer without text transcriptions,” *arXiv preprint arXiv:2106.08519*, 2021.
- [15] Ehsan Variani, Xin Lei, Erik McDermott, Ignacio Lopez Moreno, and Javier Gonzalez-Dominguez, “Deep neural networks for small footprint text-dependent speaker verification,” in *ICASSP*. IEEE, 2014, pp. 4052–4056.
- [16] Jun-Yan Zhu, Taesung Park, Phillip Isola, and Alexei A Efros, “Unpaired image-to-image translation using cycle-consistent adversarial networks,” in *ICCV*, 2017, pp. 2223–2232.
- [17] Judy Hoffman, Eric Tzeng, Taesung Park, Jun-Yan Zhu, Phillip Isola, Kate Saenko, Alexei Efros, and Trevor Darrell, “Cycada: Cycle-consistent adversarial domain adaptation,” in *ICML*. PMLR, 2018, pp. 1989–1998.
- [18] Jun-Yan Zhu, Richard Zhang, Deepak Pathak, Trevor Darrell, Alexei A Efros, Oliver Wang, and Eli Shechtman, “Multimodal image-to-image translation by enforcing bi-cycle consistency,” in *Advances in neural information processing systems*, 2017, pp. 465–476.
- [19] Zizhao Zhang, Lin Yang, and Yefeng Zheng, “Translating and segmenting multimodal medical volumes with cycle-and shape-consistency generative adversarial network,” in *CVPR*, 2018, pp. 9242–9251.
- [20] Shindong Lee, BongGu Ko, Keonnyeong Lee, In-Chul Yoo, and Dongsuk Yook, “Many-to-many voice conversion using conditional cycle-consistent adversarial networks,” in *ICASSP*. IEEE, 2020, pp. 6279–6283.
- [21] Christophe Veaux, Junichi Yamagishi, Kirsten MacDonal, et al., “Cstr vctk corpus: English multi-speaker corpus for cstr voice cloning toolkit,” *University of Edinburgh. CSTR*, 2017.
- [22] Carlos Busso, Murtaza Bulut, Chi-Chun Lee, Abe Kazemzadeh, Emily Mower, Samuel Kim, Jeannette N Chang, Sungbok Lee, and Shrikanth S Narayanan, “IEMOCAP: Interactive emotional dyadic motion capture database,” *Language resources and evaluation*, vol. 42, no. 4, pp. 335–359, 2008.