

Active noise control techniques for nonlinear systems

Lu Lu^a, Kai-Li Yin^b, Rodrigo C. de Lamare^c, Zongsheng Zheng^d, Yi Yu^e, Xiaomin Yang^{a*},
Badong Chen^f

a) School of Electronics and Information Engineering, Sichuan University, Chengdu, Sichuan 610065, China.

b) School of Computer Science, Sichuan University, Chengdu, Sichuan 610065, China.

c) CETUC, PUC-Rio, Rio de Janeiro 22451-900, Brazil.

d) School of Electrical Engineering, Sichuan University, Chengdu, 610065, China.

e) School of Information Engineering, Robot Technology Used for Special Environment Key Laboratory of Sichuan Province, Southwest University of Science and Technology, Mianyang 621010, China.

f) School of Electronic and Information Engineering, Xi'an Jiaotong University, Xi'an 710049, China.

Abstract

Most of the literature focuses on the development of the linear active noise control (ANC) techniques. However, ANC systems might have to deal with some nonlinear components and the performance of linear ANC techniques may degrade in this scenario. To overcome this limitation, nonlinear ANC (NLANC) algorithms were developed. In Part II, we review the development of NLANC algorithms during the last decade. The contributions of heuristic ANC algorithms are outlined. Moreover, we emphasize recent advances of NLANC algorithms, such as spline ANC algorithms, kernel adaptive filters, and nonlinear distributed ANC algorithms. Then, we present recent applications of ANC technique including linear and nonlinear perspectives. Future research challenges regarding ANC techniques are also discussed.

Keywords: Nonlinear active noise control, Volterra algorithms, Artificial neural networks, Kernel adaptive filters.

*The work is supported by the National Science Foundation of P.R. China under Grant 61901285, 61901400, and 61701327, Sichuan Science and Technology Fund under Grant 20YYJC3709, China Postdoctoral Science Foundation under Grant 2020T130453, and Sichuan University Postdoctoral Interdisciplinary Fund.

E-mail addresses: lulu19900303@126.com(L. Lu), kl_yin@hotmail.com(K.-L. Yin), delamare@cetuc.puc-rio.br(R.C. Lamare), zongsheng56@126.com(Z. Zheng), yuyi_xyuan@163.com(Y. Yu), arielyang@scu.edu.cn(X. Yang), chenbd@mail.xjtu.edu.cn(B. Chen).

Corresponding author: Xiaomin Yang.

1. Introduction

The celebrated filtered-x least mean square (FxLMS) algorithm and its variants have been successfully applied in active noise control (ANC) systems. However, in practical situations, the primary path $P(z)$ and secondary path $S(z)$ may be nonlinear [1]. Moreover, the reference noise $d(n)$ arises from dynamic systems and as such, the noise may be a nonlinear and deterministic or stochastic, colored, and non-Gaussian signal [2]. In these cases, linear ANC techniques cannot fully utilize the coherence in the noise and achieve suboptimal performance.

Table 1: Time line of NLANC.

Years	Authors	Contributions	References
1994	Wangler and Hansen	Genetic algorithm for nonlinear active noise and vibration control	[3]
1995	Snyder and Tanaka	ANN for NLANC	[4]
1996	Tang et al.	Genetic algorithm for ANC	[5]
1997	Tokhi and Wood	Radial basis function networks for NLANC	[6]
1998	Strauch and Mulgrew	A combined linear and nonlinear controller to compensate for the nonlinear effects	[7]
1999	Bouchard, Paillard, and Dinh	Five new algorithms for the learning of a multilayer perceptron neural network for NLANC	[8]
1997, 2001	Tan and Jiang	VFxLMS algorithm	[9, 10]
2001	Bouchard	Filtered-neuron-level extended Kalman algorithm (FxNEKA) and filtered-x extended Kalman filter (FxEKF) for NLANC	[11]
2004	Das and Panda	FsLMS algorithm	[1]
2004	Sicuranza and Carini	Volterra filtered-x affine projection (VFxAP) algorithm	[12]
2005	Sicuranza and Carini	Implementation of the VFxAP algorithm based on V-vector algebra	[13]
2005	Kuo and Wu	Bilinear FxLMS algorithm	[14]
2006	Modares, Ahmadyfard, and Hadadzarif	PSO for NLANC	[15]
2004, 2006	Zhang et al.	Fuzzy neural networks for NLANC	[16, 17]
2006	Sicuranza and Carini	Generalized Hammerstein model for NLANC	[18]
2007	Chang and Luoh	Neural-based FxLMS algorithm	[19]
2008	Bambang	Recurrent neural networks for NLANC	[20]
2008	Reddy, Das, and Prabhu	Fast FsLMS algorithm	[21]

To address these limitations, several nonlinear ANC (NLANC) algorithms were proposed, yielding a more stable performance and lower noise level [3, 12, 21]. It should be emphasized that some

NLANC methods mentioned in this paper first appeared before 2009. The research on NLANC dates back to 1995, 59 years after the concept of ANC was proposed by Lueg [22]. In this year, Snyder and Tanaka developed ANN for NLANC problem, and so far a large number of NLANC algorithms have been proposed. The milestones in the progress of NLANC before 2009 are presented in Table 1. Survey papers on NLANC techniques have been reported [2]. However, these surveys do not cover the literature since 2013. To complete the review of NLANC techniques and include the advances, in this paper we review the research progress of NLANC models in recent years.

The Volterra filter is gaining importance in NLANC. According to the *Stone-Weierstrass approximation theorem*, the Volterra filter is a ‘universal approximator’, i.e., the filter can arbitrarily approximate discrete-time with fading memory, time-invariant, continuous, finite-memory, nonlinear system [23]. The Volterra filter belongs to linear-in-the-parameters (LIP) filters, where the output depends linearly on the parameters of the filter itself. Note that this type of filter becomes computationally expensive when a large number of coefficients are required [23]. To solve this problem, the second-order Volterra (SOV) series and the third-order Volterra (TOV) series are often used. For example, in [24, 25], the Volterra filtered-x-based algorithms that use of SOV were developed for active impulsive noise control (AINC) problem.

The NLANC based on an artificial neural network (ANN) method was first studied, which provides the capacity to maintain causality within the control scheme. From 1997 to 2008, many papers discussed the usage of radial basis function (RBF) networks, recurrent neural networks (RNNs), and fuzzy neural networks for NLANC (see Table 1). In the last decade, some attempts were made by using an ANN as the controller [26, 27, 28]. A neural controller equipped with the filtered-u least mean square (FuLMS) algorithm with correction terms momentum was proposed in [29]. The correction terms momentum can efficiently prevent the system from unstable poles and can enhance the performance as compared with the conventional leaky FuLMS algorithm. Regrettably, the above mentioned ANNs have heavy computational complexity which may hinder their practical applications [2].

The functional link ANN (FLANN) exploits the single layer of ANN to obtain reliable estimation performance with acceptable error level [30]. The FLANN filter is also a type of LIP filter, which shares a unified implementation with the Volterra filter. Moreover, the linear adaptive filtering algorithms can easily extend to this framework with favorable implications on the algorithm stability and computational complexity [31]. Over the past decade, a number of filtered-s least mean square

(FsLMS) algorithms were proposed by employing FLANN, such as fast FsLMS [30], robust FsLMS (RFsLMS) [32]. Most of these algorithms use trigonometric functional expansion as the basis function, and a small number of algorithms that consider using Chebyshev [33], Fourier [34], and Legendre expansions [35] were also developed.

To compensate for the strong nonlinearity of the system with saturated signals, several bilinear algorithms with reduced computational complexity were proposed, which employ the cross-terms based on both feedback and feedforward polynomials and they can model NLANC systems with shorter filter length [36, 37]. In [38], a new bilinear filter was proposed, which uses FLANN to expand the input vector and then adapts coefficients via bilinear filter to obtain excellent nonlinear modeling capability.

In this context, the particle swarm optimization (PSO) algorithm is an effective biologically inspired meta-heuristic algorithm, which performs by a competition and cooperation mechanism between the particle swarm and thus it retains the global search strategy of population [39]. Such algorithm has been extensively studied in ANC technique, especially for nonlinear system [40]. The most obvious advantage of the PSO-ANC algorithm is that it can reduce noise without online estimation of the secondary path [40, 41]. In addition, other heuristic ANC algorithms were also developed, see [42] and references therein.

Since 2009, several attractive methods were proposed for NLANC. For performance improvement, the kernel adaptive filter (KAF) algorithm and spline adaptive filter were introduced [43, 44]. The KAF recasts the input data into a high-dimensional feature space via a reproducing kernel Hilbert space (RKHS) and as such, the linear adaptive filter is applied in the feature space [43]. In contrast, the spline adaptive filter establishes a nonlinear mathematics model by an adaptive look-up table (LUT) in which the control points are interpolated by a local low-order polynomial spline curve [44]. An important merit of the spline adaptive filter is that its computational complexity is much lower as compared to other traditional NLANC algorithms [45]. Motivated by distributed algorithms, some nonlinear distributed algorithms were proposed by integrating FLANN into distributed ANC algorithms, which is important for ensuring that the wireless acoustic sensor networks (WASNs) can combat nonlinear distortions [46].

Initial studies have shown that the KAF is limited by high computational complexity. Specifically, the input data of KAF must be a dictionary, where every new data input that arrives is used to calculate the filter output [47]. To overcome this limitation, the quantized scheme [48] and the

set-membership scheme [49] can be taken into account to start new research on the field of NLANC. For example, the adaptive step size scheme and data-selective update strategy proposed in [49] can be directly combined with the KAF in NLANC. On the other front, Internet of Things (IoT) has been shown to be compatible with communication and signal processing techniques for creating a smart world. In [50], the concept of ANC was introduced to IoT, generating *MUTE leverages*, for environmental noise cancellation. In [51], the concept system of ANC-IoT is tested. All these works have demonstrated the feasibility and great potential of the combination of the IoT and ANC.

The goal of this survey is to provide a comprehensive overview of the latest NLANC research results and innovations. We also discuss the applications of ANC techniques that have been introduced in many fields, such as functional magnetic resonance imaging (fMRI) acoustic noise control [52] and transformer noise control [53]. Moreover, we present some remarks on future research directions for ANC. The papers that have been published since 2009 are considered in this survey. In particular, the main problems that the NLANC algorithms should address are presented in Section 2. The modeling method of NLANC is discussed in Section 3, where Volterra ANC algorithms, FLANN-based algorithms, and bilinear ANC algorithms are used as examples. Section 4 focuses on evolutionary-computing-based ANC algorithms. In Section 5, some novel NLANC methods emerging in the past decade are investigated. Some important implementation issues and future research challenges of ANC are discussed in Sections 6 and 7, respectively. Finally, conclusions are provided in Section 8. All the brackets follow the order $\{[(\cdot)]\}$.

2. Problem formulation

In practical situations, three types of nonlinearities may exist in ANC systems. First of all, the primary noise at the cancellation point $d(n)$ may exhibit nonlinear effects. For instance, when the primary noise propagates in a duct with very high sound pressure, the transfer function of $P(z)$ can be well modeled by nonlinear function [33, 54].

On the other hand, the secondary plant $S(z)$ models the signal converters (A/D and D/A), power amplifiers, and transducers (actuators or speakers). The nonlinear effect may be caused by overdriving the electronics or the speakers/transducers in the secondary path [55], and the amplifier may be in saturation [56]. In these cases, the nonlinear characteristics should be considered in the mathematical model for enhanced performance. In research experiments, the transfer function

Table 2: The type and examples of nonlinearities present in ANC systems.

Type of nonlinearities	Examples
Nonlinearities in the primary path	The primary noise propagates in a duct with very high sound pressure.
Nonlinearities in the secondary path	(1) Overdriving the electronics or the speakers/transducers in the secondary path. (2) The amplifier may be in saturation.
Nonlinearities in the components of the ANC systems	(1) Actuator excites the frequency of interest and its related harmonics at the same time. (2) Actuator operates with the input signal whose amplitude is close to or higher than the nominal input signal value. (3) The working frequency of the actuator is beyond the normal frequency range (or close to the limit). (4) Noise from the blowers, grinders, airfoils, and fans is shown to be chaotic.

between the speaker and the error microphone is often modeled by *minimum* or *non-minimum phase* response.

Apart from the above two cases, some nonlinear distortions may come from the components of the control system. The most common source of nonlinearity in ANC systems is the actuator. The control actuator has typically nonlinear response characteristics, when it excites the frequency of interest and its related harmonics at the same time, and it is hoped that the ANC system will compensate and overcome such adverse effect. Furthermore, the noise arises from dynamic systems and as such, the noise may be a nonlinear and deterministic signal [24]. For example, it is known that the noise from blowers, grinders, airfoils, and fans is shown to be chaotic [57, 58]. The type and examples of nonlinearities present in ANC systems are summarized in Table 2.

In these cases, the linear ANC techniques cannot fully utilize the coherence in the noise and achieve suboptimal performance even though most adaptive algorithms [59, 60, 61, 62, 63, 64, 65, 66, 67, 68, 69, 70, 71, 72, 73, 74, 75, 76, 77, 78, 79, 80, 81, 82, 83, 84, 85, 86, 87, 88, 89, 90, 91, 92, 93, 94, 95, 96, 97, 98, 99, 100, 101, 102, 103, 104, 105, 106, 107, 108, 109, 110, 111, 112, 113, 114, 115, 116, 117, 118, 119, 120, 121, 122, 123, 124, 125, 126, 127, 128, 129, 130, 131, 132, 133, 134, 135, 136, 137, 138, 139, 140, 141, 142, 143, 144, 145, 146, 147, 148], can be adapted to NLANC scenarios. To tackle these limitations, both the models and the algorithms utilized in ANC must be properly re-designed, resulting in NLANC. There are two problems which should be addressed in NLANC: what are the practical performance characteristics of nonlinear model in this implementation, and

what are the details of an algorithm which can be used to adapt a nonlinear architecture for NLANC implementation.

3. NLANC algorithms

The modeling accuracy of NLANC systems is crucial for meeting the performance requirements of noise reduction level. This section presents different approaches for the design of NLANC.

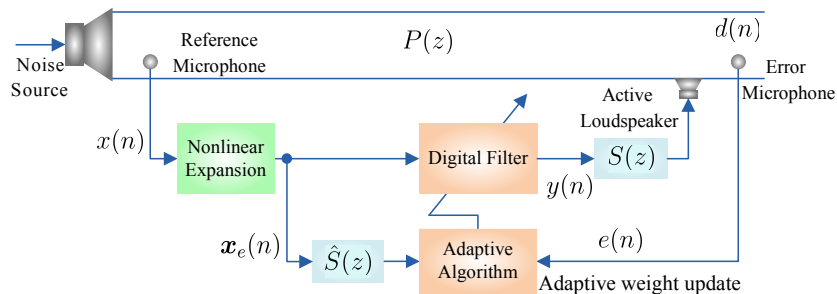

Figure 1: Diagram of feedforward NLANC system.

3.1. Volterra ANC algorithms

Nonlinear autoregressive with exogenous variables (NARX) models have been preliminarily considered for NLANC techniques. Such methods are flexible and satisfy the representation capability of nonlinear systems. In addition, the truncated Volterra filter and bilinear filter can be subsumed into the NARX model. The potential superiority of the narrowband ANC (NANC) model for NLANC applications has been emphasized in [55] and the improved version that considers the commutation of the control filter block and the secondary path dynamics was proposed in [149].

The Volterra ANC algorithms have been studied by several researchers. The preeminent merit of this modeling approaches is that they are ‘universal approximators’ that models diverse systems with satisfied performance. The block diagram of the NLANC system is shown in Fig. 1, where $e(n)$ denotes the residual noise, $\hat{S}(z)$ is the estimate of $S(z)$, $x(n)$ stands for the reference signal, $d(n)$ denotes the undesired signal, and $\mathbf{x}_e(n)$ denotes the expanded input vector. The Volterra ANC system utilizes truncated Volterra series as a nonlinear expansion. The filter output $y(n)$ of these algorithms can be represented by

$$y(n) = \sum_{q=1}^Q \sum_{m_1=0}^{M-1} \cdots \sum_{m_q=0}^{M-1} h_q(m_1, \dots, m_q) \prod_{i=1}^q x(n - m_i) \quad (1)$$

where Q denotes the order of nonlinearity, M is the memory length, and $h_q(\cdot)$ is the q th-order Volterra kernel. The filter output of (1) can be compactly rewritten as

$$y(n) = \mathbf{h}^T [\mathbf{x}_1^T(n), \mathbf{x}_2^T(n), \dots, \mathbf{x}_Q^T(n)] \quad (2)$$

where \mathbf{h} denotes the filter coefficient vector, $(\cdot)^T$ is the transposition, $\mathbf{x}_1(n) = [x(n), x(n-1), \dots, x(n-M+1)]^T$, and the thj -order input vector $\mathbf{x}_j(n)$ can be gained recursively by

$$\mathbf{x}_j(n) = \mathbf{x}_1(n) \otimes \mathbf{x}_{j-1}(n), \quad j = 2, 3, \dots, Q \quad (3)$$

where \otimes represents the Kronecker product.

In the general case with memory size M and nonlinearity order Q , the number of coefficients can be computed by $N_c = \frac{(M+Q)!}{M!Q!} - 1$. We can observe that the number of model coefficients grows in M^Q , causing an exponential dimension increase. Therefore, using a truncation strategy to limit the value of Q is indispensable in practice. For $Q = 2$, the SOV-ANC algorithm is obtained, whose filter output can be expressed as follows [24]:

$$\begin{aligned} y(n) = \mathbf{h}^T \mathbf{x}_e(n) &= \sum_{m_1=0}^{M-1} h_1(m_1)x(n-m_1) \\ &+ \sum_{m_1=0}^{M-1} \sum_{m_2=m_1}^{M-1} h_2(m_1, m_2)x(n-m_2)x(n-m_1) \end{aligned} \quad (4)$$

where the expanded input vector and filter coefficient vector can be defined by

$$\begin{aligned} \mathbf{x}_e(n) &\triangleq [\mathbf{x}_1^T(n), \mathbf{x}_2^T(n)]^T \\ &= [x(n), \dots, x(n-M+1), \end{aligned} \quad (5)$$

$$x^2(n), x(n)x(n-1), \dots, x^2(n-M+1)]^T,$$

$$\mathbf{h} \triangleq [h_1(0), h_1(1), \dots, h_1(M-1), \quad (6)$$

$$h_2(0, 0), h_2(0, 1), \dots, h_2(M-1, \dots, M-1)]^T.$$

To obtain a stable performance in a high impulsive process, for example, $\alpha = 1.1$ or 1.2 , two novel algorithms, termed as VFxlogLMP and VFxlogCLMP, were proposed [24]. These algorithms are derived from the l_p -norm of logarithmic cost and outperform than the conventional Volterra FxLMS (VFxLMS) and Volterra filtered-x least mean l_p -norm (VFxLMP) algorithms. Furthermore, it is shown in [25] that, by using the maximum correntropy criterion (MCC), the Volterra filtered-x recursive maximum correntropy (VFxRMC) algorithm can obtain good nonlinear capability with normalized and adaptive kernel size schemes.

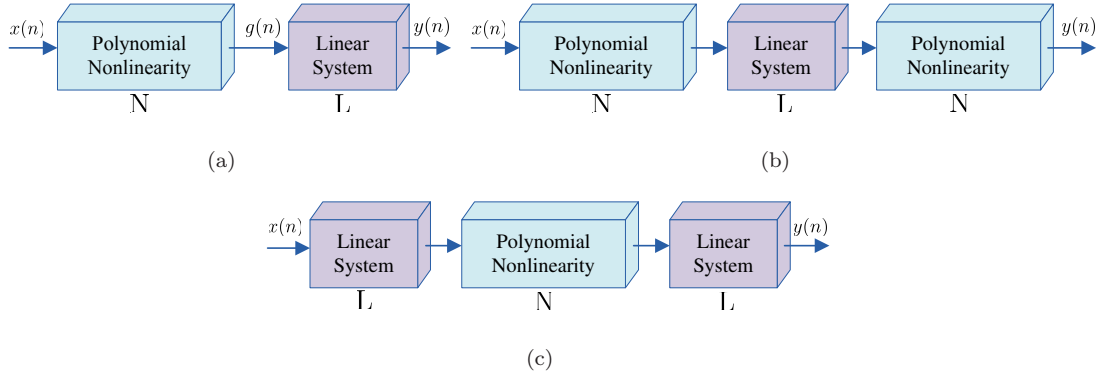

Figure 2: Structure of the nonlinear model, where N denotes the nonlinear part and L denotes the linear system. (a) Hammerstein model; (b) Hammerstein-Wiener model; (c) Wiener-Hammerstein model.

3.2. Hammerstein ANC algorithms

As the type of point-wise nonlinear expansions, the Hammerstein system model is regarded as the class of truncated Volterra filters. The basic Hammerstein system (N-L) model is comprised of a cascade connection of a memoryless nonlinearity in series with a linear system (see Fig. 2 (a)). The input-output mapping of the memoryless nonlinearity can be expressed in the form of polynomial expansion

$$g(n) = p_1x(n) + p_2x^2(n) + \dots + p_Mx^M(n) \quad (7)$$

where p_j , $j = 1, 2, \dots, M$ denotes the j th order coefficient. Combining the Wiener model (L-N), Hammerstein-Wiener model (N-L-N) is closer to the actual nonlinear system than Hammerstein model. The structure of Hammerstein-Wiener model is shown in Fig. 2 (b). Although Hammerstein-Wiener type nonlinear system has one more nonlinear link than Hammerstein and Wiener models, its essential feature is still a series of static nonlinear link and dynamic linear link. Changing the cascading order of the static nonlinear part and the dynamic linear part, the Wiener-Hammerstein model (L-N-L) can be obtained, as shown in Fig. 2 (c). The above mentioned models have been applied to NLANC system, see [150].

3.3. FLANN-based algorithms

1) *FsLMS-based algorithms*: Since the classical FsLMS algorithm was proposed in 2004, many FsLMS-type algorithms integrated with the FLANN controller were presented in the past decade, of which the trigonometric expansion is the most commonly used in FLANN. Fig. 3 shows the

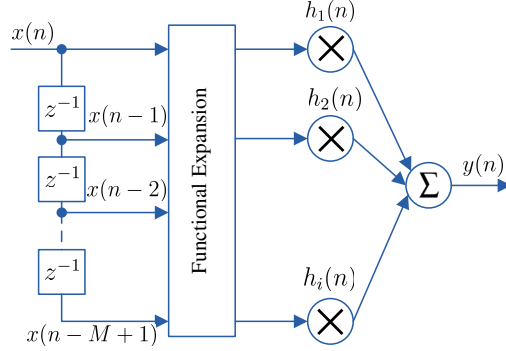

Figure 3: Structure of the FLANN.

structure of the FLANN, where $h_i(n)$ is the coefficient of the weight vector at time instant n . The reference signal and weight vector can be defined as follows [30]:

$$\begin{aligned} \mathbf{x}_e(n) \triangleq & \{x(n), \sin[\pi x(n)], \cos[\pi x(n)], \dots, \\ & \sin[b\pi x(n)], \cos[b\pi x(n)], \dots, x(n-M+1), \\ & \sin[\pi x(n-M+1)], \cos[\pi x(n-M+1)], \dots \\ & \sin[b\pi x(n-M+1)], \cos[b\pi x(n-M+1)]\}^T, \end{aligned} \quad (8)$$

$$\mathbf{h}(n) \triangleq [h_1(n), h_2(n), \dots, h_{M(2b+1)}(n)]^T \quad (9)$$

where b is the order of the FLANN filter. The number of coefficients of the FLANN filter can be calculated by $N_c = M(2b+1)$. From this result, we can see that the main advantage of FLANN-based algorithms is that it owns less computational burden than the Volterra ANC algorithm.

In [30], the FsLMS algorithm was devised for multi-channel NLANC. To achieve moderate computational complexity, the data block processing is usually preferred. In [151], a fast Fourier transform (FFT)-based block FsLMS algorithm was developed. A RFsLMS algorithm was proposed in [32], which minimizes a new logarithmic cost to obtain enhanced performance in both Gaussian and impulsive noise environments. Moreover, it extended the estimation in [152] to online update parameter. To further enhance performance, two novel NLANC algorithms were proposed based on the q -gradient method [153]. One of the algorithms was designed for Gaussian noise with time-varying q scheme; the other algorithm was intentionally designed for AINC.

2) *Generalized FLANN*: Most of the works focus on developing new FLANN algorithms, and little attention is paid for improving FLANN itself. In [31], an interesting trial was conducted

by adding suitable cross-terms between the input signal $x(n)$ and $\sin(b\pi x(n)) \cos(b\pi x(n))$ with different time shifts, resulting in generalized FLANN (GFLANN). Following this main idea, other improved GFLANNs were also developed in [154, 155].

3) *Exponential FLANN*: Inspired by Taylor series expansion that contains all odd powers of sine signal and includes all even powers for cosine signal, an exponential FLANN (EFLANN) filter was proposed for NLANC, which adds the exponential factor in trigonometric functional expansion to accelerate convergence speed [156]. After that, some algorithms were developed for further enhancement of the EFLANN, such as generalized EFLANN [157] and approximated EFLANN [158].

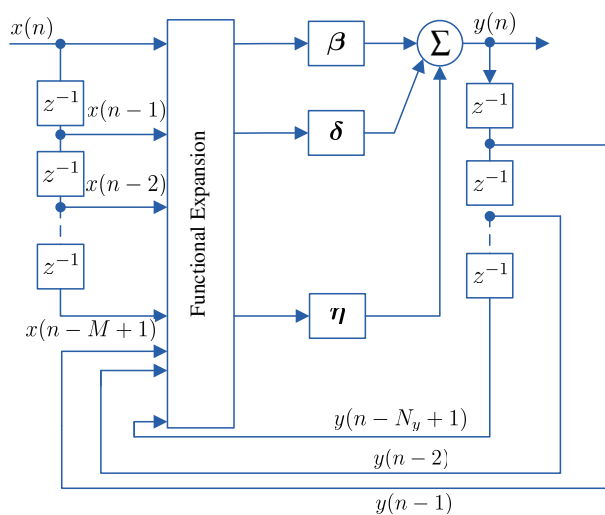

Figure 4: Structure of the RFLANN, where β , δ , and η are the parameter vector and N_y is the recent samples of the output signal.

4) *Recursive FLANN*: Recalling linear ANC systems, the filtered-u LMS (FuLMS) algorithm is capable of updating coefficients of the infinite impulse response (IIR) filter. In [159], the IIR filter with FuLMS algorithm was convexly combined with an FsLMS filter, resulting in the FsuLMS algorithm and allowing performance enhancement with respect to its component filters. Based on a bounded-input bounded-output (BIBO) stability condition, the related work [160] has confirmed that the FuLMS algorithm can also apply for NLANC. In this case, the recursive FLANN (RFLANN) filter was proposed that uses past output as part of the input signal. The block diagram of the RFLANN is shown in Fig. 4, where $\mathbf{h}^T = [\beta^T, \delta^T, \dots, \eta^T]$. As a flexible extension of LIP

filters, the RFLANN has become another important method. An application of the even mirror Fourier nonlinear (EMFN) filter to RFLANN has been considered for NLANC [161].

3.4. Orthogonal basis function-based algorithms

The above Volterra ANC algorithms are derived by Volterra series that do not satisfy orthogonal properties. In a comparison, the orthogonal property of these LIP filters can ensure fast convergence of gradient descent algorithms, thereby improving performance over non-orthogonal LIP filters. In what follows, we review the advances of some orthogonal basis function-based algorithms since 2009.

1) *Chebyshev ANC algorithms*: The Chebyshev nonlinear (CN) filter based on Chebyshev polynomials, which hold two-fold characteristics as follows. I) Chebyshev polynomials are a family of orthogonal polynomials. II) Chebyshev polynomials converge faster than expansions in other sets of polynomials. The Chebyshev polynomials are given by the generating function [33]

$$T_{q+1}(x) = 2xT_q(x) - T_{q-1}(x), \quad (10)$$

where $x \in [-1, 1]$, $T_0(x) = 1$, and q is the order of Chebyshev polynomials expansion. The closed-form expression for Chebyshev polynomials of any order is expressed as

$$T_q(x) = \sum_{i=0}^{\lfloor \frac{q}{2} \rfloor} (-1)^i \binom{q}{2i} x^{q-2i} (1-x^2)^i \quad (11)$$

where $\lfloor q/2 \rfloor$ denotes the integer part of $(q/2)$. The corresponding function expansion using Chebyshev polynomials (increased from 1 to Q) is expressed as (12).

The novel CN filter was proposed in [33], whose input of CN filter is derived from correlated empirical mode decomposition (CEMD) method. As shown in [33], such Chebyshev ANC algorithm outperforms the known FsLMS and VFxLMS algorithm in noise reduction and convergence rate.

2) *Fourier ANC algorithms*: Despite the FLANN and GFLANN filter significantly reduce the computational complexity, they do not satisfy the condition of the Stone-Weierstrass theorem. Therefore, they cannot be universal approximators of Volterra filters, i.e., these types of filters are unable to model arbitrary systems. In [34], a Fourier nonlinear (FN) filter was investigated for NLANC, where trigonometric basis functions are designed to avoid repetition or cancellation terms. However, as discussed in [162], the discontinuities on the borders of the unit hypercube cause relevant oscillations in the Fourier expansion of continuous function.

$$\begin{aligned}
\mathbf{x}_e(n) = & \{1, T_1[x(n)], T_1[x(n-1)], \dots, T_1[x(n-M+1)], T_1[x(n)]T_1[x(n-1)], \\
& \dots, T_1[x(n-M+2)]T_1[x(n-M+1)], T_2[x(n)], T_2[x(n-1)], \dots, T_2[x(n-M+1)], \\
& \dots, T_Q[x(n)], T_Q[x(n-1)], \dots, T_Q[x(n-M+1)]\}^T
\end{aligned} \tag{12}$$

$$\begin{aligned}
\mathbf{x}_e(n) = & \left\{ \sin\left[\frac{\pi}{2}x(n)\right], \sin\left[\frac{\pi}{2}x(n-1)\right], \dots, \sin\left[\frac{\pi}{2}x(n-M+1)\right], \cos[\pi x(n)], \right. \\
& \dots, \cos[\pi x(n-M+1)], \sin\left[\frac{\pi}{2}x(n)\right] \sin\left[\frac{\pi}{2}x(n-1)\right], \\
& \dots, \sin\left[\frac{\pi}{2}x(n-M+1)\right] \sin\left[\frac{\pi}{2}x(n-M+1)\right], \dots, \\
& \left. \sin\left[\frac{\pi}{2}x(n-M+3)\right] \sin\left[\frac{\pi}{2}x(n-M+1)\right], \dots, \sin\left[\frac{\pi}{2}x(n)\right] \sin\left[\frac{\pi}{2}x(n-M+1)\right] \right\}^T
\end{aligned} \tag{13}$$

$$\begin{aligned}
\mathbf{x}_e(n) = & \{L_0[x(n)], L_1[x(n)], \dots, L_Q[x(n)], \dots, L_1[x(n-M+1)], L_2[x(n-M+1)], \\
& \dots, L_Q[x(n-M+1)]\}^T
\end{aligned} \tag{14}$$

To tackle this challenge, the EMFN filter was proposed for approximation, by formulating the truncation of a multidimensional even symmetric generalized Fourier series [162]. For the second-order EMFN filter, the input signal $\mathbf{x}_e(n)$ is expanded to $N_c = \frac{M(M+3)}{2}$ coefficients as (13)¹. The EMFN filter was successfully employed to solve NLANC problems. The work [163] embedded the EMFN filter inside of the RFLANN structure under the BIBO stability condition. Numerical simulation results indicated that above modified EMFN filters are feasible and effective for solving NLANC problems. The work in [164] developed two novel EMFN and CN filters with sparse modeling of nonlinear secondary path, which can significantly reduce computational load without sacrificing the control performance. Moreover, it showed that the EMFN filter outperforms the CN filter with sparse modeling.

3) *Legendre ANC algorithms*: The Legendre nonlinear (LN) filter is also an orthogonal universal approximators, which shares closed properties with FN and EMFN filters. The Legendre polynomial can be obtained by the following formula [35]:

$$L_{q+1}(x) = \frac{1}{q+1} [(2q+1)xL_q(x) - qL_{q-1}(x)] \quad q > 2,$$

¹The length of SOV filter has the same calculation as the second-order EMFN filter.

where $L_q(x)$ denotes the q th order Legendre polynomial derived from the solution of the differential equation $\frac{d}{dx} \left[(1-x^2) \frac{dy}{dx} \right] + q(q+1)y = 0$ and $L_0(x) = 1$. The expanded input vector of the LN filter is shown in (14). In 2013, a new algorithm was suggested in [35], which uses a cascade structure of FLANN and LN filters. Since the LN filter requires $x \in [-1, 1]$ for stability, a function $\tanh(\cdot)$ is used to link the output of FLANN and the input of the LN filter. Simulation results demonstrated improved performance as compared to the FsLMS algorithm [35].

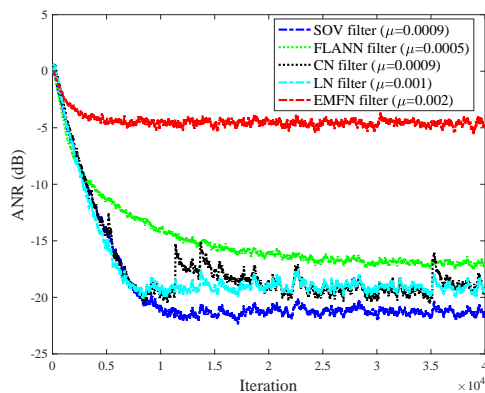

Figure 5: Averaged noise reductions (ANRs) of the representative NLANC algorithms, where the filter length of all algorithms is set to 77 and simulation settings are the same as Example 1 in [153].

We compare representative NLANC algorithms in Fig. 5 for a scenario described in [153], where the LMS algorithm is utilized to update weight vector, and $\alpha = 2$ is used as the reference signal. The results show that the SOV filter has the best performance, followed by the LN filter and the CN filter, which have comparable noise residual performance.

3.5. Bilinear ANC algorithms

The deteriorated performance of the SOV filter is achieved when strong nonlinear distortions occurred in the ANC system [36]. The bilinear filter is developed to address this problem with shorter filter length. The input-output relationship of the bilinear filter is given by

$$\begin{aligned}
 y(n) = & \sum_{i=0}^{N_1} a_i(n)x(n-i) + \sum_{t=1}^{N_1} b_t(n)y(n-t) \\
 & \sum_{i=0}^{N_1} \sum_{t=1}^{N_1} c_{i,t}(n)x(n-i)y(n-t)
 \end{aligned} \tag{15}$$

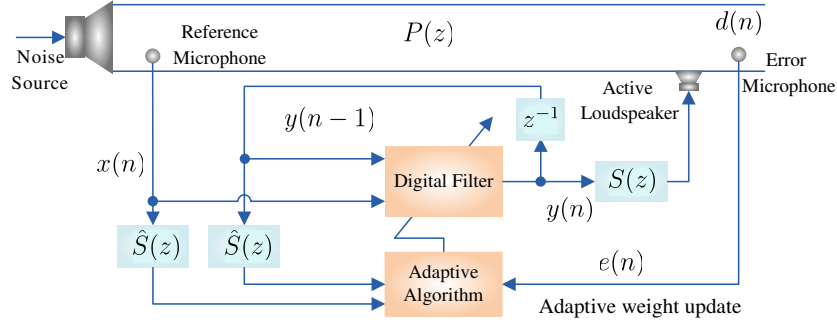

Figure 6: Structure of the bilinear filter.

where $a_i(n)$, $b_t(n)$, and $c_{i,t}(n)$ are the coefficients with N_1 , $N_1 + 1$ and $N_1(N_1 + 1)$ elements, respectively. The block diagram of the convention bilinear filter for ANC problem is shown in Fig. 6.

As can be seen, the bilinear filter has $x(n)$, $y(n)$, and $x(n-i)y(n-t)$ with different time shifts. An update method, namely diagonal-channel structure, was proposed in [165]. This structure updates the weights of these terms independently to acquire improved performance. By using this structure, the FxLMS and filtered-x recursive least square (FxRLS) algorithms were proposed and a counterpart with sequential channel update was developed [165]. Using the properties of the diagonal-channel can also reduce the computational complexity of the bilinear filter [166, 167]. In [168], two diagonal strategies were devised for the bilinear filter in the context of NLANC system, which omits some diagonal elements to significantly reduce the computational complexity by sacrificing performance of the algorithm.

In recent years, the FLANN-inspired bilinear filters [37, 169, 38, 36, 170] received much attention owing to their good modeling capability. For the ANC system with saturation nonlinearity, a general function expansion bilinear filter with a 3-D diagonal-channel structure was proposed, where a trigonometric-based FLANN expansion diagonal-channel structure bilinear filter is presented [37]. Aimed at improving the performance of a control system with a nonlinear secondary path, a FxLMS algorithm using reweighted bilinear filters was proposed and a generalized filter to model different nonlinear secondary paths was explored in [169]. In [38], the FLANN was introduced to the bilinear filter for NLANC, which adapts the coefficients by diagonal-channel structure and achieves refined performance than the FLANN and GFLANN. Then, the leaky bilinear filter with filtered-error LMS (FeLMS) and PU scheme was subsequently developed to enhance stability and reduce computational

Table 3: Number of coefficients for the algorithms.

Nonlinear model	Number of coefficients	Special instruction
Volterra filter	$N_c = \frac{(M+Q)!}{M!Q!} - 1$	SOV filter: $N_c = \frac{M(M+3)}{2}$
Hammerstein filter	$N_c = M + L_F$	The nonlinear part of Hammerstein filter does not require historical input and output information
FLANN filter	$N_c = M(2b + 1)$	Based on trigonometric expansions
GFLANN filter	$N_c = 2M + 1$	Generally, $b = 1$ in the GFLANN filter
EFLANN filter	$N_c = M(2b + 1) + 1$	Require exponential operation
CN filter	$N_c = 1 + Q(M + 1) + M$	Generally, $Q \leq 3$ in the CN filter
FN filter	$N_c = 2 \sum_{j=0}^{Q-1} \binom{Q-1}{j} \binom{M+j}{Q}$ (for Q th order)	Second-order ENFN filter: $N_c = \frac{M(M+3)}{2}$ ENFN filter is suitable for modeling strong nonlinearities
LN filter	$N_c = QM + 1$	Suitable for modeling mild and medium nonlinearities
Bilinear filter	$N_c = N_1^2 + 3N_1 + 1$	Suitable for modeling strong nonlinearities with saturated signals

complexity [36]. The number of coefficients for the NLANC algorithms based on nonlinear expansion is outlined in Table 3, where L_F denotes the FIR memory size and N_c denotes the number of coefficients of the order Q .

3.6. Discussion

In this subsection, we discuss some existing strategies in NLANC systems. Most of these schemes have been reviewed in Part I of this work, and can be extended to solve the ANC problem under nonlinear distortions.

The remote microphone technique (RMT) has been used for NLANC in the past decade. In [171], the RMT is incorporated into the empirical weight update (EWU) algorithm to circumvent the slow convergence problem of stochastic approximation methods and PSO algorithms. Based on FLANN controller, a novel FeLMS algorithm with RMT was proposed in [172], which exhibits its computational advantages and reliable performance for the sinusoidal signal. Its FsLMS counterpart also has been proposed in [57].

As stated in Part I, the convex combination scheme can substantially improve the performance of linear ANC. Such a strategy is also applicable to NLANC systems. The first attempt of convex combination for NLANC can be found in [173]. In this work, two different nonlinear modeling methods, FLANN and Volterra, were performed by convex combination to obtain enhanced performance.

The MCC not only has been used to the Volterra FxRLS algorithm [25], but also has been applied to normalized versions of the FsLMS algorithm [174]. As a generalization of the minimum error entropy (MEE) criterion, Rényi’s entropy has been applied to NLANC. A generalized filtered-x integrated-evaluation-criterion-based gradient descent (GFx-IECGD) algorithm was presented, whose update equation is mixed by the mean square error (MSE) criterion and Rényi’s entropy [27].

The chaotic noise commonly exists in NLANC system, and some researchers developed various algorithms to control such type of noise. The work in [175] considers ANC of a mixture of tonal and chaotic noise via the hybrid FLANN method. The effort in [58] first explored the characteristic of logistic chaotic noise and applied FLANN for active chaotic noise control. It was observed that the logistic chaotic noise 1 is highly broadband, while the logistic chaotic noises 2~6 are mostly broadband with some frequency notches [58]. To enhance readability, we summarize these schemes in Table 4.

Table 4: Contributions of the algorithms in Section 3.

RMT	Convex Combination algorithms	Entropy-based algorithms
[171, 172, 57]	[159, 173, 176]	[25, 174, 27]
Chaotic signal control	Leaky algorithms	PU-based algorithms
[176, 36, 38, 170] [57, 175, 58, 177]	[36, 170]	[36]

4. Heuristic-based ANC algorithms

Both linear and nonlinear ANC tasks can be solved by transforming into a global optimization problem. Especially for NLANC systems, such problems are well-suitable for considering global optimization problems, because the nonlinear secondary path may cause the conventional adaptive filter to suffer from the local minima trapping phenomenon in non-convex or non-deterministic polynomial (NP)-hard problems, and it turns out the degraded reduction performance. The first heuristic algorithm used to optimize ANC was the genetic algorithm (GA) in 1994 [3]. Afterward, the PSO algorithm was applied to the NLANC problem in 2006. The relevant time line can be referred to Table 1.

1) *Genetic algorithms*: The GAs are inspired by Darwin's evolution theory, which seeks the optimal solution by studying the evolutionary process of simulation. In [178], the adaptive GA (AGA)-based ANC system was designed for various environments. Besides, this work confirmed that the AGA can suppress the nonlinear noise interference without estimating the secondary path. The use of the interior-point method (IPM) for GA-ANC has also been proved to be an effective technique [179]. The IPM searches for the optimal solution by traversing the internal feasible region, and it shows excellent performance for solving linear or quadratic constraint optimization problems. Benefiting from this, GA-ANC systems can further enhance reduction performance for various noises.

2) *Backtracking search algorithms*: Closer to the GA is the backtracking search algorithms (BSA), which are a population-based iterative evolutionary algorithm (EA) designed to prevent the algorithm from falling into a local optimum. In [180], the BSA integrated with sequential quadratic programming (SQP) was proposed for ANC systems with sinusoidal signal and complex random signal, which can obtain improved performance without modeling $S(z)$.

3) *PSO algorithms*: Based on the competition and cooperation mechanism between the particle swarm, the PSO can produce a swarm intelligence to guide the optimization search. By exploiting the soft bound $\tanh\{\cdot\}$ as the saturation nonlinearity module of the secondary path, the PSO has been applied to ANC in [39]. Specifically, it can tackle the cases with varying saturation grades of both reference and secondary paths. Similar to the GA, the PSO-ANC can also reduce noise without exact estimation of the secondary path, see [40, 41, 181]. As a nonlinear FLANN extension of [40], the algorithm in [182] was trained by PSO for multi-channel NLANC systems, which is subsequently developed into a decentralized version. In the PSO-literature, a less common exploration strategy is the Wilcoxon norm [183], which has been proved to have effectiveness for data contaminated by outliers. It has been shown through simulation experiments in [183] that considerable reduction can be obtained as compared with the MSE criterion.

4) *Bacterial foraging optimization algorithms*: The bacterial foraging optimization (BFO) is based on the foraging behavior of *escherichia coli* bacteria in human intestine. Bacteria look for nutrients to maximize the energy gained in a unit of time. They go through different stages of chemotaxis, swarming, reproduction and elimination-and-dispersal. Such BFO algorithms have been successfully employed to adapt the coefficients of the NLANC controller, which outperforms the standard GA-ANC by nearly 5dB in steady-state [184, 185].

In addition to the above mentioned heuristic algorithms, other heuristic algorithms have been studied in the ANC system. The firefly (FF) algorithm was a classical optimization and has been used to NLANC. The new algorithm cascades the FLANN and FIR filter, and adopts the FF algorithm to obtain coefficients [186]. The fireworks algorithm (FWA) is also a swarm intelligence algorithm inspired by the fireworks explosion. The research in [42] reveals the profound optimization capacity of the three variants of FWA for NLANC.

5. Novel NLANC methods emerging in past decade

In this section, we present some novel NLANC approaches, such as spline ANC algorithms, KAF ANC algorithms, and nonlinear distributed ANC algorithms, proposed in the last ten years.

5.1. Spline ANC algorithms

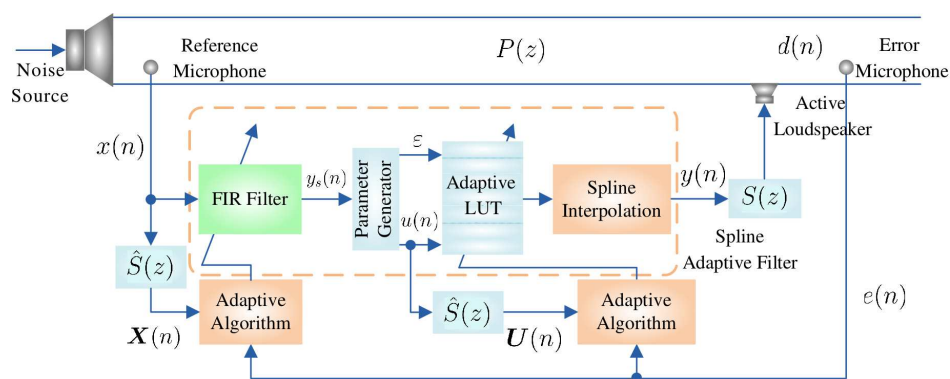

Figure 7: Structure of the NLANC system with spline adaptive filter.

In 2013, the spline adaptive filter was originally proposed for nonlinear system identification, whose adaptation is based on a spline function [44]. As shown in [44] and references therein, the spline adaptive filter enjoys good nonlinear modeling performance in diverse applications and owns low computational cost. Such spline adaptive filter was extended to address NLANC problem in [187]. The schematic of the NLANC system with a spline adaptive filter is shown in Fig. 7, where $\mathbf{U}(n)$ is the filtered signal of $\mathbf{u}(n) = [u^3(n), u^2(n), u(n), 1]^T$, and ε denotes the span index, and $u(n)$ is the local parameter, which can be computed by

$$\varepsilon = \left\lfloor \frac{y_s(n)}{\Delta x} \right\rfloor + \frac{C-1}{2} \quad (16a)$$

$$u(n) = \frac{y_s(n)}{\Delta x} - \left\lfloor \frac{y_s(n)}{\Delta x} \right\rfloor \quad (16b)$$

where $y_s(n)$ denotes the output of the finite impulse response (FIR) filter, Δx denotes the gap between the control points, C denotes the total number of control points in the activation function, and $\lfloor \cdot \rfloor$ stands for the floor operation. Then, the generated parameters pass through the adaptive look-up table (LUT) and are interpolated by a local low order polynomial spline curve. Hence, the output of the spline adaptive filter is

$$y(n) = \mathbf{u}^T(n)\mathbf{\Omega}\mathbf{q} \quad (17)$$

where $\mathbf{\Omega}$ is the pre-computed spline basis matrix and \mathbf{q} is the control point vector.

As an initial step towards multi-channel spline adaptive filters, the algorithm proposed in [188] has obvious advantages in terms of computational complexity and final MSE level when compared to the multi-channel VFxLMS and FsLMS algorithms. Furthermore, the advantages of the FIR spline adaptive filter can also refer to [189]. In 2016, a novel infinite impulse response (IIR) spline adaptive filter was proposed [45], which corresponds to the use of a feedback scheme and the FuLMS algorithm. Compared with the FIR filters, the main merit of using IIR filters is their implementation efficiency.

5.2. KAF-ANC algorithms

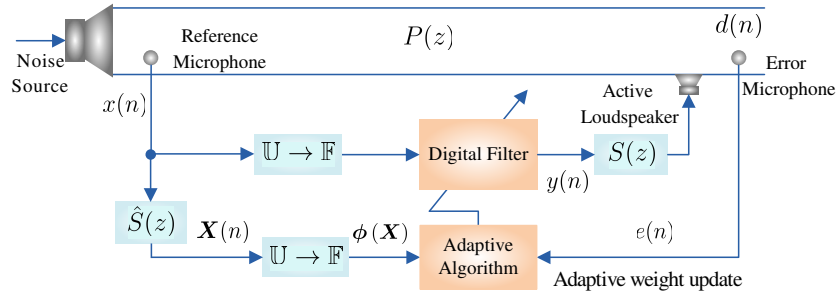

Figure 8: Structure of the NLANC system with KAF.

The kernel trick has become rather popular and has been successfully applied to adaptive filtering. The key idea of the KAF is to recast the input data from input space \mathbb{U} into a high-dimensional feature space \mathbb{F} via a reproducing kernel Hilbert space (RKHS). As a result, the inner product operations in linear adaptive filters are translated to the calculation of a kernel function $\kappa(\cdot)$ in the feature space without knowing the exact nonlinear mapping.

The KAF was first applied to NLANC system in 2009 [43]. The basic block diagram of the ANC with KAF is shown in Fig. 8, where $\phi : \mathbb{U} \rightarrow \mathbb{F}$ denotes feature vector. By using *Mercer theorem*, the inner products in RKHS can be calculated as

$$\kappa(\mathbf{X}, \mathbf{X}') = \phi(\mathbf{X}) \phi^T(\mathbf{X}') \quad (18)$$

where $\mathbf{X}, \mathbf{X}' \in \mathbb{U}$ and the kernel function $\kappa(\cdot)$ often uses Gaussian kernel, which is expressed as $\kappa(\mathbf{X}, \mathbf{X}') = \exp(-\varsigma \|\mathbf{X} - \mathbf{X}'\|^2)$, where ς is the kernel size and $\|\cdot\|$ denotes the l_2 -norm. Finally, the filter output can be expressed as

$$y(n) = \sum_{j=1}^n a_j \langle \phi(\mathbf{X}), \phi(\mathbf{X}_j) \rangle \quad (19)$$

where a_j denotes the coefficient and $\langle \cdot \rangle$ denotes the inner product operation. The work in [43] considered the scenario that chaotic noise and only the primary path $P(z)$ is nonlinear, which has certain limitations. The reference [190] made up for this shortcoming, which took the nonlinear secondary path into account. Moreover, some multi-tonal and sinusoidal noise sources are simulated. The choice of the kernel function is crucial to the performance of the kernel algorithm, and most works employed Gaussian kernel as a default choice due to its universal approximating capability, numerical stability, and desirable smoothness. The work in [191] specifically discussed the selection of different kernel functions. Three novel kernel functions, namely logistic kernel, tan-sigmoid kernel, and inverse-tan kernel, were proposed and subsequently applied to KAF for NLANC. Its simulation results demonstrated the improved performance by using new kernel functions.

It should be noted that the above mentioned KAF and spline adaptive filters have been exhibited improved performance as compared to the conventional FsLMS and VFxLMS algorithms [187, 190]. Hence, we can conclude that the KAF and spline adaptive filters are good candidates for NLANC.

5.3. Nonlinear distributed ANC algorithms

The idea of a nonlinear distributed ANC system is basically derived from a linear distributed ANC network. The difference lies in the use of function expansion strategies. In [46], a nonlinear distributed multi-channel ANC algorithm was proposed followed by the diffusion strategy, where the LN filter is employed and both primary and secondary paths are considered to be nonlinear. Fig. 9 shows the structure of the nonlinear distributed multi-channel ANC algorithm, where $i = 1, 2, \dots, I$, I denotes the number of loudspeaker, $k = 1, 2, \dots, K$, and K denotes the number of error

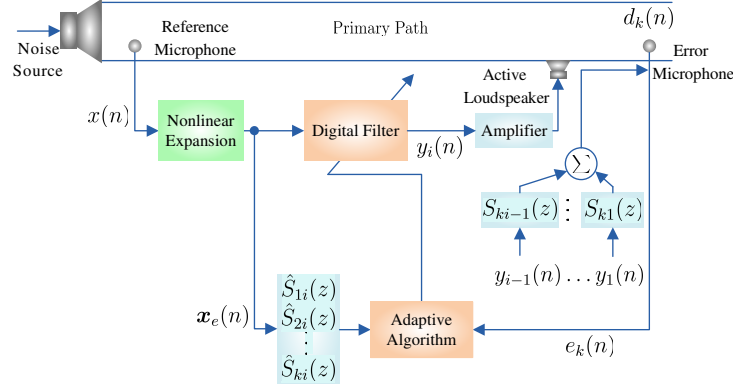

Figure 9: Structure of the nonlinear distributed multi-channel ANC system.

sensors. Very recently, a new nonlinear distributed ANC system was presented by using incremental implementation and adaptive EFLANN expansion, which exhibits lower computational cost than the distributed ANC system with the FsLMS, VFxLMS, and conventional EFLANN controller [192].

6. Recent implementations and applications of ANC

In this section, the application development of ANC in the past decade is discussed. Before we start, it should be highlighted that many applications have been developed before last decade (see time line of ANC applications in Table 5). These works have laid the foundation for the implementations and applications of ANC in the past ten years.

6.1. ANC implementation

1) *DSP implementation:* ANC techniques have been implemented in real-time systems such as digital signal processor (DSP), field programmable gate array (FPGA), and very large scale integration (VLSI). Several hardware implementations dedicated to studying lower-power consumption and small area realization have been reported. The compensated-FxLMS algorithm implemented by fixed-point DSP was presented in [203]. However, such method requires a specialized measurement of the devices in the control system. In addition, the round-off and quantization errors will change with the programmer's code implementation, and the correct values of the phase and amplitude compensation factors need to be determined [204]. An improvement of fixed-point DSP method

Table 5: Time line of ANC applications.

Years	Authors	Contributions	References
1993	Craig and Angevine	Active transformer noise control	[193]
1994	Sutton et al.	ANC for road noise	[194]
1997	McJury et al.	ANC for fMRI	[195]
2002	Gan and Kuo	Integrated feedback ANC for headset	[196]
2002	Qiu et al.	Waveform synthesis method for active transformer noise control	[197]
2003	Jakob and Möser	ANC with double-glazed windows	[198, 199]
2003	Pinte, Desmet, and Sas	Iterative learning control algorithm for ANC systems	[200]
2005	Zhou et al.	Back-propagation (BP) -FeLMS algorithm	[201]
2006	Kuo, Mitra, and Gan	Feedback ANC for headphone	[202]

was proposed in [204], which added feedback and *communication error*² Considering the implementation of different structures in fixed-point DSP, a detailed performance comparison of FxLMS, FxNLMS, IIR, and subband ANC algorithms was presented in [205]. The research results showed that the FxLMS and its variant are more suitable for ANC implementation and the fixed-point DSP has about 2dB degradation as compared with its floating-point counterpart.

2) *FPGA implementation*: The DSP owns limited processing capability and it is intended for low sampling rate applications. In contrast, the performance of the FPGA implementation largely depends on the selection of FPGA device. Several algorithms and architectures were proposed for performance enhancement with high-speed computational architecture [206, 207, 208]. The novel algorithm, called filtered-weight FxLMS (FwFxLMS), was proposed [206]. The FwFxLMS algorithm can efficiently increase the upper-bound of the step size and as such, accelerating the convergence rate of algorithm without affecting the stability. Devoted to reducing computational load of multi-channel ANC system, a novel architecture of FPGA was proposed to solve the conflicted requirement between throughput and hardware resource consumption by using parallel execution

²The definition of communication error can be found in Eq. (12), Part I of this work.

and folding [207].

3) *VLSI implementation*: The VLSI provides a large amount of calculation in a small area, and the resource assumptions is significantly reduced compared to FPGA and DSP. The effort in [209] focused on VLSI implementation on the FxLMS and FsLMS algorithms. Prior to this, few literature considered the implementation of NLANC algorithms. By devising folded structures of the algorithm, the intentionally proposed delay FsLMS algorithm becomes easy to use in practice.

6.2. ANC through open window

ANC through open windows technique can attenuate noise while maintaining natural ventilation in dwellings [210, 211, 212, 213, 214]. The finite-element-based ANC methods have been used to establish the control performance and the passive attenuation offered by the open window [215, 216]. In [215], an ANC system with 16-channel and secondary sources distributed evenly across the opening was implemented with a full-sized window, yielding more than 5dB below 2000Hz overall attenuation. However, the size of an opening influences the control performance and the opening windows may also introduce noise at the same time [217]. To avoid this issue, a scheme of small opening in the wall was implemented in [218]. To design an ANC system with reduced computational complexity of DSP implementation and acceptable level of noise reduction, a novel multi-channel ANC method was proposed for opening window. By preprocessing the error signals, the number of inputs to the controller can be decreased and a good performance can be achieved when it employs 4-channel ANC system with 0.2×0.2 m opening window [219].

6.3. Headphone application

Many headphone applications of ANC were developed based on DSP, FPGA and VLSI implementations [220]. Some algorithms focus on implementing ANC headphones with less resources, head-tracking problems, multi-channel, and multi-reference [221, 222, 223]. The most popular algorithm used in ANC headphone is the feedback FxLMS algorithm. A number of (in-ear) headphones based on the feedback ANC system were implemented [224, 225]. Their performance comparison of feedback ANC system with different circuit implementations can be seen in [226]. In [227], a hybrid feedback ANC scheme was presented by making use of the combination of classical and adaptive feedback ANC techniques. Considering that system delay will limit implementation performance in practice, this work also proposed a mixed analog-digital realization to maintain very low system delay in the classic part and enable adaptive ANC components to adapt to the digital domain.

In comparison, a feedforward structure was adopted for binaural ANC system in [228]. It is worth pointing out that the performance improvement of [228] also benefits from the use of the parametric array loudspeakers (PAL) as the secondary sources. Similar techniques have been applied to ANC problems such as steerable PAL [229] and curved-type PAL [230]. Also considering the use of a binaural ANC system, a combined bilateral-binaural ANC (CBBANC) system was proposed for closed-back headphones [231]. By switching between the binaural and bilateral implementation, the improved performance can be obtained as compared to the conventional bilateral ANC headphones.

The ANC headphone application has also embedded some techniques discussed above. For example, in [232], the virtual sensing method was adopted. Particularly, in [232], the FsLMS algorithm with nonlinear virtual microphone was developed for active headrest application, which considers the nonlinear distortion in the presence of primary noise. The prediction filter was another method applied in feedback ANC headphones, which does not need any real-time coefficient updates and is therefore very economical [233].

6.4. Zone-of-quiet based approach

The traditional ANC technique can only minimize the noise level at the location where the error microphone is placed. Correspondingly, a zone-of-quiet (ZoQ) is created around this error microphone. However, unless multiple sensors are used, it is not technically possible to control or monitor noise levels in ZoQ. The applications of spherical loudspeakers arrays for ANC has been presented to extend ZoQ [234]. Following the idea of [234, 235], several improvements were proposed including linear array [236], and RMT-based methods [237]. To design larger ZoQ, a method was proposed by introducing one and two secondary sources, which aimed at maximizing the area of the 10dB quiet zones [238]. By introducing feedforward adaptive ANC structure to control shape and extension of ZoQ, a new avenue was proposed in [239], which has capability of creating a controllable spherical quiet zone via a compensation factor. Moreover, in [240], a ZoQ method equipped with memetic algorithm (MA) and distributed adaptation has been proposed, which holds high potential for practical applications.

The ZoQ based methods have been integrated into ANC for speech enhancement in hearing aids. In [241], the ANC with noise reduction strategy was proposed for a specific ZoQ. Following a different direction, the method in [242] developed two schemes. The former method is based on the MSE criterion at a remote point, and the latter method is based on an average MSE criterion over

a desired ZoQ. Moreover, several approaches on integrated ANC and noise reduction for hearing aids have been proposed, such as those proposed in [243, 244, 245] and references therein.

6.5. Spatial ANC approach

Spatial ANC is designed to attenuate noise within a specific space. Since there is not only one space point but the space must be controlled, many transducers are needed. A direct method to achieve spatial ANC is to employ the multi-channel FxLMS algorithm. However, such method cannot guarantee that the spatial noise is also reduced, and the calculation cost is high. To address this drawback, several mode-domain methods were proposed in [246, 247, 248, 249]. Such methods can significantly reduce computational complexity since the mode-domain conversions can reduce the cross-correlations between transducers. In addition, the filter update can be computed by a mode-independent manner. Very recently, a new spatial ANC method was developed, where the higher-order source (HOS) scheme is used to improve controllability of efficiency and error [250].

6.6. fMRI acoustic noise control

The problem of fMRI acoustic noise control is a research focus in the application of ANC technology. Studies showed that when magnetic resonance imaging (MRI) scans, it can generate acoustic noise up to 130dB [52]. So far, a large number of ANC algorithms were proposed for fMRI problem, see [251, 252] and references therein. The followed articles implemented by head-mounted ANC system with piezoelectric loudspeakers and optical microphones [253] or RMT [254]. The effectiveness of the FxRLS-FxNLMS algorithms on fMRI noise control was validated that the hybrid algorithm can gain a very fast convergence [52]. This group then proposed an improved parallel feedback ANC system [255], which parallels two FxNLMS algorithms with the NLMS decomposition to achieve exceeding 40dB noise attenuation level.

The adaptive comb filters (ACFs) that perform a coordinated search, have been applied to fMRI noise control. Based on the previous works, i.e., SONIC (self-optimizing narrowband interference canceller) [256, 257, 258], the ACF incorporated SONIC algorithm was suggested for active fMRI noise control [259]. This algorithm can track the fundamental frequency and the amplitude of different frequency components of non-stationary harmonic signals embedded in white measurement noise. However, its reduction level is limited to 20dB. For performance improvement, a discrete Fourier transformation (DFT)-based frequency-domain ANC algorithm for fMRI noise control was

proposed in [260], which can achieve approximately 35dB overall reduction in the frequency range of interest.

6.7. Periodic noise control

Based on different characteristic distributions with time, the exhaust noise can be divided into three types: steady, periodic, and intermittent [261]. Among the three types, the periodic noise is the most widely encountered and has great research significance. The repetitive impulsive noise belongs to a category of periodic noise and has many practical backgrounds. For example, when compressed air escapes regularly through the exhaust pipe, it generates repetitive impulsive noise, up to 120dB. In the past decade, many studies have focused on and analyzed this kind of noise. Similarly, the FxLMS algorithm and its variants can also be used to attenuate this noise [262].

The iterative learning control (ILC) algorithm is another method that can effectively control repetitive impulsive noise, which can be regarded as the adaptive feedforward algorithm. In ILC controllers, the control signal is adapted to the specific repetitive of transient noise. It runs repetitively in an open-loop over a finite time interval to reduce the same discrete interference at each time instant. Related to the ILC method is the well-known repetitive control (RC) algorithm, which can also be interpreted as the adaptive feedforward algorithm. The ILC and RC algorithms share the same core idea, that is, it should be possible to improve the performance of a system that repeatedly performs the same repetitive task. The difference is that the RC algorithm has continuously active property.

It demonstrated in [263, 264] that the drawbacks of conventional ILC and RC methods are high computational complexity and low robustness of the controllers. To solve these problems, a novel strategy to design non-causal ILC and RC filters was described, with emphasis on the application of ANC. It can achieve 4dB noise reduction with the frequency-domain ILC filter. Owing to the fact that the ILC and RC algorithms are closely related, many design methods can be used in both algorithms. For example, in [265], a non-causal transversal FIR filter was combined with the optimal ILC algorithm for active repetitive impulsive noise control, and then it was applied to the optimal RC algorithm [261].

6.8. Transformer noise control

Transformer noise is typically characterized by even and multiples of the line frequency of the fundamental and harmonic frequencies. Generally, the fundamental frequency does not vary

by more than $\pm 0.5\%$ [53]. Therefore, using the internally synthesized preset frequency signal as a reference signal for transformer noise control may be a reasonable way. In [53], the classical FxLMS algorithm with an internally synthesized reference signal was proposed, which can obtain a maximum of 15dB noise reduction. Motivated by the online and offline secondary path modeling strategy, a novel FxLMS algorithm was presented for 50000KVA transformer noise control [266]. Simulations demonstrated that an 84.10~96.86% decrease in average sound energy density can be obtained in a certain area.

6.9. ANC in vehicles

ANC in vehicles requires a good spatial and temporal matching between the fields of the actuator or secondary sources [267]. Spatial matching requires that the wavelength of the acoustic wave for active noise control must be small, whereas time matching demands the system can adapt to changes in vehicle speed and load [268]. Owing to the fact that ANC has a significant improvement, particularly at low-frequency and on vehicles with specific problems, such technique has been widely used in vehicles [269]. In the past ten years, many prominent companies and corporations have proposed effective solutions to this problem, see references in [267]. In [270], three feedback ANC systems were investigated based on internal model control (IMC) architecture and frequency discretization method. Moreover, the multi-channel algorithm has addressed ANC of road noise in vehicles [271, 272]. In [272], eight reference sensors located around the four wheels were devised to obtain a broadband reduction of 4dB up to 1kHz. In [273], a variable step-size (VSS) median-least mean square algorithm was presented for active rail vehicle interior noise control. In [274] and [275], the leaky FxLMS and multi-channel FxLMS algorithms have been respectively applied to ANC for yacht.

The ANC technique is quite general and its application is not limited to the above mentioned works. The ANC principle has already been used for mobile phones [276], earmuff systems [277, 278], high-speed elevators [279], mufflers [280], and washing machines [281]. In [282, 283], the single and multi-channel ANC systems have been employed for ventilation duct. Furthermore, new problems in the ANC system, such as broadband noise fields in rooms [284], electroencephalogram (EEG) signal analysis [285] have also been studied. These applications show the great application potential of ANC.

We note that a number of papers on NLANC assume the presence of nonlinearities that are

Table 6: Implementations and applications of NLANC in Section 6.

Contributions	Benefits	References
FsLMS implementation	The proposed delayed block FsLMS (DBFsLMS) structure involves 58% less area-delay product and 41% less energy per sample than the FxLMS structure.	[209]
Generalized filter bank based nonlinear ANC algorithm	The new algorithm is suitable for a headrest application with head movement, and the effective area of active headrest is achieved as high as 45 cm \times 45 cm.	[286]
NLANC with virtual microphone control	These methods can control noise at a remote location when the system is nonlinear.	[57, 172, 232]

difficult to encounter in real-world applications. Therefore, most of above mentioned works are based on linear assumptions and do not consider nonlinear characteristics. To clearly show the benefits offered by a nonlinear approach with respect to the linear one, the implementations and applications of NLANC are summarized in Table 6.

7. Future research challenges

Some future challenges of ANC have been discussed in [56, 287]. In this section, we present a number of promising directions for future ANC research from other perspectives.

7.1. Theoretical analysis of algorithms

As we discussed in Part I of this work, the fractional lower order moment (FLOM)-based algorithms can be effectively used for AINC. The problem of interest is to analyze the theoretical performance of the FLOM-based algorithms in the presence of α -stable noise. However, such a topic is extremely difficult since the variance of α -stable noise is infinite, leading to some assumptions does not satisfy the conditions. As far as we know, researchers did not consider the case in which the error in α -stable noise environment is changing across iterations. Moreover, the steady-state and transient performance of conventional least mean p th power (LMP) algorithm has not been investigated in the presence of α -stable noise. The lack of these analysis foundations causes the analysis of the FLOM-based algorithms exactly difficult.

The similar problem also exists in the analysis of LIP algorithms, such as the FN and EMFN. Moreover, since the input vectors of these algorithms are expanded by different basis functions, the behavior of algorithms is more complicated.

7.2. Sparsification for KAF-ANC

Despite the above KAF algorithms are well applied in NLANC, there are still problems to be solved. For system identification problem, several KAF algorithms with curb of network size were proposed. Since the network size of the KAF linearly increases with the number of training data, which means that the filter length is very high during adaptation. The problem of NLANC is the same as that of KAF for system identification. This increase in complexity can be harnessed through the application of some sparsification techniques, for example, the quantized scheme in [48] and the set-membership scheme in [49]. These strategies can curb the number of input data into the kernel function at each iteration. If it is detected that not enough new information is carried in the input signal, it will be abandoned as the redundant data.

7.3. The application of Internet of Things to ANC

IoT attracts significant attention in the fields of location, smart transportation, and signal processing. Based on the concept of IoT, the ANC technique has been applied to IoT. By utilizing wireless communication with acoustics, IoT was brought into the ANC context, which provided a potential solution to urban noise pollution [50]. Through DSP implementation verification, the proof of concept (PoC) system was stated, which allows the concept of IoT to be applied in the field of ANC [51]. In this work, the analog cables were replaced by digital ethernet transmission, resulting in a more flexible system that is easier to be rearranged and modified.

It is noted that existing ANC-IoT schemes rely on the single-node device, and the impact of practical constraints, such as impulsive noise, the nonlinear distortions, and distributed implementation, on the performance of ANC-IoT has not been investigated yet. Furthermore, as discussed before, ANC can effectively suppress the noise in vehicles. Hence, ANC may be specifically applied to the Internet of Vehicles (IoV).

7.4. Discussion

Currently, NLANC has made much progress. In the following, some future directions that are peculiar to NLANC are presented.

- 1) For NLANC algorithms, most of the algorithms are still at the theoretical and laboratory stage, and they are not fully utilized in practical applications. For the future directions of nonlinear algorithms in NLANC, it needs to curb its computational complexity. Since the nonlinear filtering

problem is inherently infinite dimensional, the substantial increase of data samples can prohibit practical applications of NLANC algorithms. Therefore, low complexity NLANC algorithms are an important research direction in the future.

2) Selecting the optimal memory length of the NLANC algorithm for the corresponding nonlinear systems is also a research direction. In the field of echo cancellation, the memory control scheme of Volterra filter has been studied [288]. However, it has not been investigated in the NLANC adaptive filtering algorithms. Such a problem is also applicable to the heuristic-based algorithms in NLANC. The optimal size of populations for heuristic-based algorithms is of great significance to the reduced computational complexity and improved performance.

3) Further exploration of NLANC technology in specific practical scenarios are required. Currently, NLANC does not seem to find its most suitable breakthrough point for large-scale commercial applications. Thus, finding a cost-effective application scenario is also an important future research direction of NLANC.

8. Conclusion

In this survey paper, we have discussed state-of-the-art methods related to NLANC technique, including FsLMS-based algorithms, distributed extension and selected applications. We have also summarized FLANN approaches as well as the Chebyshev, EMFN, and LN filters. The spline adaptive filter, kernel adaptive filter, and nonlinear distributed ANC algorithms are the new nonlinear modeling approaches considered for NLANC. Due to technical limitations, these open areas need further investigations of sophisticated NLANC techniques. The review of implementations for both linear and nonlinear ANC are merged together. We have also discussed the main challenges for future ANC techniques.

Acknowledgment

The authors would like to thank the associate editor and the anonymous referees for their valuable comments.

References

References

- [1] D. P. Das, G. Panda, Active mitigation of nonlinear noise processes using a novel filtered-s LMS algorithm, *IEEE Trans. Speech, Audio Process.* 12 (3) (2004) 313–322.
- [2] N. V. George, G. Panda, Advances in active noise control: A survey, with emphasis on recent nonlinear techniques, *Signal Process.* 93 (2) (2013) 363–377.
- [3] C. T. Wangler, C. H. Hansen, Genetic algorithm adaptation of non-linear filter structures for active sound and vibration control, in: *Proc. IEEE Int. Conf. Acoust., Speech, Signal Process.*, Vol. 3, 1994, pp. 505–508.
- [4] S. D. Snyder, N. Tanaka, Active control of vibration using a neural network, *IEEE Trans. Neural Netw.* 6 (4) (1995) 819–828.
- [5] K.-S. Tang, K.-F. Man, S. Kwong, C.-Y. Chan, C. Chu, Application of the genetic algorithm to real-time active noise control, *Real-Time Syst.* 11 (3) (1996) 289–302.
- [6] M. O. Tokhi, R. Wood, Active noise control using radial basis function networks, *Control Eng. Pract.* 5 (9) (1997) 1311–1322.
- [7] P. Strauch, B. Mulgrew, Active control of nonlinear noise processes in a linear duct, *IEEE Trans. Signal Process.* 46 (9) (1998) 2404–2412.
- [8] M. Bouchard, B. Paillard, C. T. Le Dinh, Improved training of neural networks for the nonlinear active control of sound and vibration, *IEEE Trans. Neural Netw.* 10 (2) (1999) 391–401.
- [9] L. Tan, J. Jiang, Filtered-X second-order Volterra adaptive algorithms, *Electron. Lett.* 33 (8) (1997) 671–672.
- [10] L. Tan, J. Jiang, Adaptive Volterra filters for active control of nonlinear noise processes, *IEEE Trans. Signal Process.* 49 (8) (2001) 1667–1676.
- [11] M. Bouchard, New recursive-least-squares algorithms for nonlinear active control of sound and vibration using neural networks, *IEEE Trans. Neural Netw.* 12 (1) (2001) 135–147.

- [12] G. L. Sicuranza, A. Carini, Filtered-X affine projection algorithm for multichannel active noise control using second-order Volterra filters, *IEEE Signal Process. Lett.* 11 (11) (2004) 853–857.
- [13] G. L. Sicuranza, A. Carini, A multichannel hierarchical approach to adaptive Volterra filters employing filtered-X affine projection algorithms, *IEEE Trans Signal Process.* 53 (4) (2005) 1463–1473.
- [14] S. M. Kuo, H.-T. Wu, Nonlinear adaptive bilinear filters for active noise control systems, *IEEE Trans. Circuits Syst. I* 52 (3) (2005) 617–624.
- [15] H. Modares, A. Ahmadyfard, M. Hadadzarif, A PSO approach for non-linear active noise cancellation, in: *Proc. the 6th WSEAS Int. Conf. Simul., Modell., Optim.*, 2006, pp. 492–497.
- [16] Q. Zhang, W.-S. Gan, Active noise control using a simplified fuzzy neural network, *J. Sound Vib.* 1 (272) (2004) 437–449.
- [17] Q. Zhang, W.-S. Gan, Y. Zhou, Adaptive recurrent fuzzy neural networks for active noise control, *J. Sound Vib.* 296 (4-5) (2006) 935–948.
- [18] G. L. Sicuranza, A. Carini, On the accuracy of generalized hammerstein models for nonlinear active noise control, in: *Proc. IEEE Instrum. Meas. Technol.*, 2006, pp. 1411–1416.
- [19] C.-Y. Chang, F.-B. Luoh, Enhancement of active noise control using neural-based filtered-X algorithm, *J. Sound Vib.* 305 (1-2) (2007) 348–356.
- [20] R. T. Bambang, Adjoint EKF learning in recurrent neural networks for nonlinear active noise control, *Appl. Soft Comput.* 8 (4) (2008) 1498–1504.
- [21] E. P. Reddy, D. P. Das, K. M. M. Prabhu, Fast adaptive algorithms for active control of nonlinear noise processes, *IEEE Trans. Signal Process.* 56 (9) (2008) 4530–4536.
- [22] L. Paul, Process of silencing sound oscillations, US Patent 2043416 (Jun. 9 1936).
- [23] P. M. S. Burt, J. H. D. M. Goulart, Efficient computation of bilinear approximations and Volterra models of nonlinear systems, *IEEE Trans. Signal Process.* 66 (3) (2018) 804–816.

- [24] L. Lu, H. Zhao, Adaptive Volterra filter with continuous l_p -norm using a logarithmic cost for nonlinear active noise control, *J. Sound Vib.* 364 (2016) 14–29.
- [25] Z. C. He, H. H. Ye, E. Li, An efficient algorithm for nonlinear active noise control of impulsive noise, *Appl. Acoust.* 148 (2019) 366–374.
- [26] N. L. Thai, X. Wu, J. Na, Y. Guo, N. T. T. Tin, P. X. Le, Adaptive variable step-size neural controller for nonlinear feedback active noise control systems, *Appl. Acoust.* 116 (2017) 337–347.
- [27] X. Zhang, X. Ren, J. Na, B. Zhang, H. Huang, Adaptive nonlinear neuro-controller with an integrated evaluation algorithm for nonlinear active noise systems, *J. Sound Vib.* 329 (24) (2010) 5005–5016.
- [28] N. Azadi, A. Ohadi, Filtered gradient active fuzzy neural network noise control in an enclosure backed by a clamped plate, *Int. J. Adapt. Control Signal Process.* 26 (5) (2012) 451–468.
- [29] C.-Y. Chang, Neural filtered-U algorithm for the application of active noise control system with correction terms momentum, *Digit. Signal Process.* 20 (4) (2010) 1019–1026.
- [30] E. P. Reddy, D. P. Das, K. M. M. Prabhu, Fast exact multichannel FSLMS algorithm for active noise control, *Signal Process.* 89 (5) (2009) 952–956.
- [31] G. L. Sicuranza, A. Carini, A generalized FLANN filter for nonlinear active noise control, *IEEE Trans. Audio, Speech Lang. Process.* 19 (8) (2011) 2412–2417.
- [32] N. V. George, G. Panda, A robust filtered-s LMS algorithm for nonlinear active noise control, *Appl. Acoust.* 73 (8) (2012) 836–841.
- [33] B. Chen, S. Yu, Y. Yu, R. Guo, Nonlinear active noise control system based on correlated EMD and Chebyshev filter, *Mech. Syst. Signal Process.* 130 (2019) 74–86.
- [34] A. Carini, G. L. Sicuranza, A new class of FLANN filters with application to nonlinear active noise control, in: *European Signal Processing Conference, 2012*, pp. 1950–1954.
- [35] N. V. George, G. Panda, Active control of nonlinear noise processes using cascaded adaptive nonlinear filter, *Appl. Acoust.* 74 (1) (2013) 217–222.

- [36] D. C. Le, D. Li, J. Zhang, M-max partial update leaky bilinear filter-error least mean square algorithm for nonlinear active noise control, *Appl. Acoust.* 156 (2019) 158–165.
- [37] X. Guo, Y. Li, J. Jiang, C. Dong, S. Du, L. Tan, Adaptive function expansion 3-D diagonal-structure bilinear filter for active noise control of saturation nonlinearity, *IEEE Access* 6 (2018) 65139–65150.
- [38] D. C. Le, J. Zhang, Y. Pang, A bilinear functional link artificial neural network filter for nonlinear active noise control and its stability condition, *Appl. Acoust.* 132 (2018) 19–25.
- [39] N. K. Rout, D. P. Das, G. Panda, Particle swarm optimization based nonlinear active noise control under saturation nonlinearity, *Appl. Soft Comput.* 41 (2016) 275–289.
- [40] N. K. Rout, D. P. Das, G. Panda, Particle swarm optimization based active noise control algorithm without secondary path identification, *IEEE Trans. Instrum. Meas.* 61 (2) (2012) 554–563.
- [41] N. K. Rout, D. P. Das, G. Panda, PSO based adaptive narrowband ANC algorithm without the use of synchronization signal and secondary path estimate, *Mech. Syst. Signal Process.* 114 (2019) 378–398.
- [42] W. U. Khan, Z. Ye, F. Altaf, N. I. Chaudhary, M. A. Z. Raja, A novel application of fireworks heuristic paradigms for reliable treatment of nonlinear active noise control, *Appl. Acoust.* 146 (2019) 246–260.
- [43] H. Bao, I. M. Panahi, Active noise control based on kernel least-mean-square algorithm, in: *Proc. 43th Asilomar Conf. Signals Syst. Comput.*, 2009, pp. 642–644.
- [44] M. Scarpiniti, D. Comminiello, R. Parisi, A. Uncini, Nonlinear spline adaptive filtering, *Signal Process.* 93 (4) (2013) 772–783.
- [45] V. Patel, N. V. George, Compensating acoustic feedback in feed-forward active noise control systems using spline adaptive filters, *Signal Process.* 120 (2016) 448–455.
- [46] R. Kukde, G. Panda, M. S. Manikandan, On distributed non-linear active noise control using diffusion collaborative learning strategy, *IET Signal Process.* 12 (4) (2018) 410–421.

- [47] W. Liu, J. C. Príncipe, S. Haykin, *Kernel Adaptive Filtering: A Comprehensive Introduction*, John Wiley & Sons, 2011.
- [48] B. Chen, S. Zhao, P. Zhu, J. C. Príncipe, Quantized kernel least mean square algorithm, *IEEE Trans. Neural Netw. Learn. Syst.* 23 (1) (2012) 22–32.
- [49] A. Flores, R. C. de Lamare, Set-membership adaptive kernel NLMS algorithms: Design and analysis, *Signal Process.* 154 (2019) 1–14.
- [50] S. Shen, N. Roy, J. Guan, H. Hassanieh, R. R. Choudhury, MUTE: bringing IoT to noise cancellation, in: *Proc. Conf. of the ACM Special Interest Group on Data Commun.*, 2018, pp. 282–296.
- [51] R. Galambos, L. Sujbert, Active noise control in the concept of IoT, in: *Proc. 16th Int. Carpathian Control Conf.*, 2015, pp. 133–137.
- [52] R. M. Reddy, I. M. S. Panahi, R. W. Briggs, Hybrid FxRLS-FxNLMS adaptive algorithm for active noise control in fMRI application, *IEEE Trans. Control Syst. Technol.* 19 (2) (2011) 474–480.
- [53] L. Zhang, J. Tao, X. Qiu, Active control of transformer noise with an internally synthesized reference signal, *J. Sound Vib.* 331 (15) (2012) 3466–3475.
- [54] L. Luo, J. Sun, B. Huang, D. D. Quoc, Efficient combination of feedforward and feedback structures for nonlinear narrowband active noise control, *Signal Process.* 128 (2016) 494–503.
- [55] R. Napoli, L. Piroddi, Nonlinear active noise control with NARX models, *IEEE Trans. Audio Speech Lang. Process.* 18 (2) (2010) 286–295.
- [56] S. M. Kuo, K. Kuo, W.-S. Gan, Active noise control: Open problems and challenges, in: *Int. Conf. Green Circuits Syst.*, 2010, pp. 164–169.
- [57] D. P. Das, D. J. Moreau, B. S. Cazzolato, A nonlinear active noise control algorithm for virtual microphones controlling chaotic noise, *J. Acoust. Soc. Amer.* 132 (2) (2012) 779–788.
- [58] S. B. Behera, D. P. Das, N. K. Rout, Nonlinear feedback active noise control for broadband chaotic noise, *Appl. Soft Comput.* 15 (2014) 80–87.

- [59] R. C. de Lamare, R. Sampaio-Neto, Adaptive reduced-rank processing based on joint and iterative interpolation, decimation, and filtering, *IEEE Transactions on Signal Processing* 57 (7) (2009) 2503–2514. doi:10.1109/TSP.2009.2018641.
- [60] R. C. de Lamare, R. Sampaio-Neto, Minimum mean-squared error iterative successive parallel arbitrated decision feedback detectors for ds-cdma systems, *IEEE Transactions on Communications* 56 (5) (2008) 778–789. doi:10.1109/TCOMM.2008.060209.
- [61] R. de Lamare, R. Sampaio-Neto, Adaptive reduced-rank mmse filtering with interpolated fir filters and adaptive interpolators, *IEEE Signal Processing Letters* 12 (3) (2005) 177–180. doi:10.1109/LSP.2004.842290.
- [62] R. C. de Lamare, Adaptive and iterative multi-branch mmse decision feedback detection algorithms for multi-antenna systems, *IEEE Transactions on Wireless Communications* 12 (10) (2013) 5294–5308. doi:10.1109/TWC.2013.092013.130233.
- [63] R. C. de Lamare, R. Sampaio-Neto, Reduced-rank adaptive filtering based on joint iterative optimization of adaptive filters, *IEEE Signal Processing Letters* 14 (12) (2007) 980–983. doi:10.1109/LSP.2007.907995.
- [64] R. C. de Lamare, R. Sampaio-Neto, Reduced-rank space-time adaptive interference suppression with joint iterative least squares algorithms for spread-spectrum systems, *IEEE Transactions on Vehicular Technology* 59 (3) (2010) 1217–1228. doi:10.1109/TVT.2009.2038391.
- [65] R. C. de Lamare, R. Sampaio-Neto, Adaptive reduced-rank equalization algorithms based on alternating optimization design techniques for mimo systems, *IEEE Transactions on Vehicular Technology* 60 (6) (2011) 2482–2494. doi:10.1109/TVT.2011.2157187.
- [66] R. Fa, R. C. de Lamare, L. Wang, Reduced-rank stap schemes for airborne radar based on switched joint interpolation, decimation and filtering algorithm, *IEEE Transactions on Signal Processing* 58 (8) (2010) 4182–4194. doi:10.1109/TSP.2010.2048212.
- [67] R. C. de Lamare, M. Haardt, R. Sampaio-Neto, Blind adaptive constrained reduced-rank parameter estimation based on constant modulus design for cdma interference suppression, *IEEE Transactions on Signal Processing* 56 (6) (2008) 2470–2482. doi:10.1109/TSP.2007.913161.

- [68] P. Clarke, R. C. de Lamare, Transmit diversity and relay selection algorithms for multirelay cooperative mimo systems, *IEEE Transactions on Vehicular Technology* 61 (3) (2012) 1084–1098. doi:10.1109/TVT.2012.2186619.
- [69] P. Li, R. C. De Lamare, Adaptive decision-feedback detection with constellation constraints for mimo systems, *IEEE Transactions on Vehicular Technology* 61 (2) (2012) 853–859. doi:10.1109/TVT.2011.2177874.
- [70] Z. Yang, R. C. de Lamare, X. Li, ℓ_1 -regularized stap algorithms with a generalized sidelobe canceler architecture for airborne radar, *IEEE Transactions on Signal Processing* 60 (2) (2012) 674–686. doi:10.1109/TSP.2011.2172435.
- [71] R. de Lamare, R. Sampaio-Neto, Adaptive mber decision feedback multiuser receivers in frequency selective fading channels, *IEEE Communications Letters* 7 (2) (2003) 73–75. doi:10.1109/LCOMM.2002.808373.
- [72] R. de Lamare, L. Wang, R. Fa, Adaptive reduced-rank lcmv beamforming algorithms based on joint iterative optim, *Signal Processing* 90 (2) (2010) 640–652. doi:<https://doi.org/10.1016/j.sigpro.2009.08.002>. URL <https://www.sciencedirect.com/science/article/pii/S0165168409003466>
- [73] H. Ruan, R. C. de Lamare, Robust adaptive beamforming using a low-complexity shrinkage-based mismatch estimation algorithm, *IEEE Signal Processing Letters* 21 (1) (2014) 60–64. doi:10.1109/LSP.2013.2290948.
- [74] R. C. de Lamare, P. S. R. Diniz, Set-membership adaptive algorithms based on time-varying error bounds for cdma interference suppression, *IEEE Transactions on Vehicular Technology* 58 (2) (2009) 644–654. doi:10.1109/TVT.2008.926608.
- [75] R. de Lamare, R. Sampaio-Neto, Blind adaptive code-constrained constant modulus algorithms for cdma interference suppression in multipath channels, *IEEE Communications Letters* 9 (4) (2005) 334–336. doi:10.1109/LCOMM.2005.04022.
- [76] S. Xu, R. C. de Lamare, H. V. Poor, Distributed compressed estimation based on compressive sensing, *IEEE Signal Processing Letters* 22 (9) (2015) 1311–1315. doi:10.1109/LSP.2015.2400372.

- [77] R. C. De Lamare, R. Sampaio-Neto, A. Hjørungnes, Joint iterative interference cancellation and parameter estimation for cdma systems, *IEEE Communications Letters* 11 (12) (2007) 916–918. doi:10.1109/LCOMM.2007.070943.
- [78] R. Fa, R. C. De Lamare, Reduced-rank stap algorithms using joint iterative optimization of filters, *IEEE Transactions on Aerospace and Electronic Systems* 47 (3) (2011) 1668–1684. doi:10.1109/TAES.2011.5937257.
- [79] R. C. de Lamare, R. Sampaio-Neto, Adaptive interference suppression for ds-cdma systems based on interpolated fir filters with adaptive interpolators in multipath channels, *IEEE Transactions on Vehicular Technology* 56 (5) (2007) 2457–2474. doi:10.1109/TVT.2007.899931.
- [80] R. C. De Lamare, R. Sampaio-Neto, Blind adaptive mimo receivers for space-time block-coded ds-cdma systems in multipath channels using the constant modulus criterion, *IEEE Transactions on Communications* 58 (1) (2010) 21–27. doi:10.1109/TCOMM.2010.01.070549.
- [81] R. de Lamare, R. Sampaio-Neto, Low-complexity variable step-size mechanisms for stochastic gradient algorithms in minimum variance cdma receivers, *IEEE Transactions on Signal Processing* 54 (6) (2006) 2302–2317. doi:10.1109/TSP.2006.873651.
- [82] A. G. D. Uchoa, C. T. Healy, R. C. de Lamare, Iterative detection and decoding algorithms for mimo systems in block-fading channels using ldpc codes, *IEEE Transactions on Vehicular Technology* 65 (4) (2016) 2735–2741. doi:10.1109/TVT.2015.2432099.
- [83] R. Fa, Multi-branch successive interference cancellation for mimo spatial multiplexing systems: design, analysis and simulation, *IET Communications* 5 (2011) 484–494(10).
URL <https://digital-library.theiet.org/content/journals/10.1049/iet-com.2009.0843>
- [84] N. Song, R. C. de Lamare, M. Haardt, M. Wolf, Adaptive widely linear reduced-rank interference suppression based on the multistage wiener filter, *IEEE Transactions on Signal Processing* 60 (8) (2012) 4003–4016. doi:10.1109/TSP.2012.2197747.
- [85] L. T. N. Landau, R. C. de Lamare, Branch-and-bound precoding for multiuser mimo systems with 1-bit quantization, *IEEE Wireless Communications Letters* 6 (6) (2017) 770–773. doi:10.1109/LWC.2017.2740386.

- [86] H. Ruan, R. C. de Lamare, Robust adaptive beamforming based on low-rank and cross-correlation techniques, *IEEE Transactions on Signal Processing* 64 (15) (2016) 3919–3932. doi:10.1109/TSP.2016.2550006.
- [87] S. D. Somasundaram, N. H. Parsons, P. Li, R. C. de Lamare, Reduced-dimension robust capon beamforming using krylov-subspace techniques, *IEEE Transactions on Aerospace and Electronic Systems* 51 (1) (2015) 270–289. doi:10.1109/TAES.2014.130485.
- [88] T. Wang, R. C. de Lamare, P. D. Mitchell, Low-complexity set-membership channel estimation for cooperative wireless sensor networks, *IEEE Transactions on Vehicular Technology* 60 (6) (2011) 2594–2607. doi:10.1109/TVT.2011.2153884.
- [89] T. Peng, R. C. de Lamare, A. Schmeink, Adaptive distributed space-time coding based on adjustable code matrices for cooperative mimo relaying systems, *IEEE Transactions on Communications* 61 (7) (2013) 2692–2703. doi:10.1109/TCOMM.2013.043013.120788.
- [90] N. Song, W. U. Alokozai, R. C. de Lamare, M. Haardt, Adaptive widely linear reduced-rank beamforming based on joint iterative optimization, *IEEE Signal Processing Letters* 21 (3) (2014) 265–269. doi:10.1109/LSP.2013.2295943.
- [91] R. Meng, R. C. de Lamare, V. H. Nascimento, Sparsity-aware affine projection adaptive algorithms for system identification, in: *Sensor Signal Processing for Defence (SSPD 2011)*, 2011, pp. 1–5. doi:10.1049/ic.2011.0144.
- [92] J. Liu, R. C. de Lamare, Low-latency reweighted belief propagation decoding for ldpc codes, *IEEE Communications Letters* 16 (10) (2012) 1660–1663. doi:10.1109/LCOMM.2012.080312.121307.
- [93] R. C. de Lamare, R. Sampaio-Neto, Sparsity-aware adaptive algorithms based on alternating optimization and shrinkage, *IEEE Signal Processing Letters* 21 (2) (2014) 225–229. doi:10.1109/LSP.2014.2298116.
- [94] L. Wang, Constrained adaptive filtering algorithms based on conjugate gradient techniques for beamforming, *IET Signal Processing* 4 (2010) 686–697(11).
URL <https://digital-library.theiet.org/content/journals/10.1049/iet-spr.2009.0243>

- [95] Y. Cai, R. C. de Lamare, R. Fa, Switched interleaving techniques with limited feedback for interference mitigation in ds-cdma systems, *IEEE Transactions on Communications* 59 (7) (2011) 1946–1956. doi:10.1109/TCOMM.2011.051711.090120A.
- [96] Y. Cai, R. C. de Lamare, Space-time adaptive mmse multiuser decision feedback detectors with multiple-feedback interference cancellation for cdma systems, *IEEE Transactions on Vehicular Technology* 58 (8) (2009) 4129–4140. doi:10.1109/TVT.2009.2022830.
- [97] Z. Shao, R. C. de Lamare, L. T. N. Landau, Iterative detection and decoding for large-scale multiple-antenna systems with 1-bit adcs, *IEEE Wireless Communications Letters* 7 (3) (2018) 476–479. doi:10.1109/LWC.2017.2787159.
- [98] R. de Lamare, Joint iterative power allocation and linear interference suppression algorithms for cooperative ds-ss systems, *IET Communications* 6 (2012) 1930–1942(12).
URL <https://digital-library.theiet.org/content/journals/10.1049/iet-com.2011.0508>
- [99] P. Li, R. C. de Lamare, Distributed iterative detection with reduced message passing for networked mimo cellular systems, *IEEE Transactions on Vehicular Technology* 63 (6) (2014) 2947–2954. doi:10.1109/TVT.2013.2295532.
- [100] Y. Cai, R. C. de Lamare, B. Champagne, B. Qin, M. Zhao, Adaptive reduced-rank receive processing based on minimum symbol-error-rate criterion for large-scale multiple-antenna systems, *IEEE Transactions on Communications* 63 (11) (2015) 4185–4201. doi:10.1109/TCOMM.2015.2475260.
- [101] C. T. Healy, R. C. de Lamare, Design of ldpc codes based on multipath emd strategies for progressive edge growth, *IEEE Transactions on Communications* 64 (8) (2016) 3208–3219. doi:10.1109/TCOMM.2016.2579641.
- [102] L. Wang, R. C. de Lamare, M. Haardt, Direction finding algorithms based on joint iterative subspace optimization, *IEEE Transactions on Aerospace and Electronic Systems* 50 (4) (2014) 2541–2553. doi:10.1109/TAES.2014.120395.
- [103] J. Gu, R. C. de Lamare, M. Huemer, Buffer-aided physical-layer network coding with optimal linear code designs for cooperative networks, *IEEE Transactions on Communications* 66 (6) (2018) 2560–2575. doi:10.1109/TCOMM.2017.2708118.

- [104] S. Xu, R. C. de Lamare, H. V. Poor, Adaptive link selection algorithms for distributed estimation, *EURASIP J. Adv. Signal Process.* 86.
- [105] L. Wang, R. C. de Lamare, Y. Long Cai, Low-complexity adaptive step size constrained constant modulus sg algorithm, *Signal Processing* 89 (12) (2009) 2503–2513. doi:<https://doi.org/10.1016/j.sigpro.2009.04.018>.
URL <https://www.sciencedirect.com/science/article/pii/S0165168409001716>
- [106] L. Qiu, Y. Cai, R. C. de Lamare, M. Zhao, Reduced-rank doa estimation algorithms based on alternating low-rank decomposition, *IEEE Signal Processing Letters* 23 (5) (2016) 565–569. doi:[10.1109/LSP.2016.2541688](https://doi.org/10.1109/LSP.2016.2541688).
- [107] M. Yukawa, R. C. de Lamare, R. Sampaio-Neto, Efficient acoustic echo cancellation with reduced-rank adaptive filtering based on selective decimation and adaptive interpolation, *IEEE Transactions on Audio, Speech, and Language Processing* 16 (4) (2008) 696–710. doi:[10.1109/TASL.2008.916059](https://doi.org/10.1109/TASL.2008.916059).
- [108] S. Xu, Distributed estimation over sensor networks based on distributed conjugate gradient strategies, *IET Signal Processing* 10 (2016) 291–301(10).
URL <https://digital-library.theiet.org/content/journals/10.1049/iet-spr.2015.0384>
- [109] L. Landau, Robust adaptive beamforming algorithms using the constrained constant modulus criterion, *IET Signal Processing* 8 (2014) 447–457(10).
URL <https://digital-library.theiet.org/content/journals/10.1049/iet-spr.2013.0166>
- [110] L. Wang, R. C. de Lamare, Adaptive constrained constant modulus algorithm based on auxiliary vector filtering for beamforming, *IEEE Transactions on Signal Processing* 58 (10) (2010) 5408–5413. doi:[10.1109/TSP.2010.2054086](https://doi.org/10.1109/TSP.2010.2054086).
- [111] Y. Cai, R. C. de Lamare, Adaptive linear minimum ber reduced-rank interference suppression algorithms based on joint and iterative optimization of filters, *IEEE Communications Letters* 17 (4) (2013) 633–636. doi:[10.1109/LCOMM.2013.021213.122594](https://doi.org/10.1109/LCOMM.2013.021213.122594).
- [112] T. G. Miller, S. Xu, R. C. de Lamare, H. V. Poor, Distributed spectrum estimation based on alternating mixed discrete-continuous adaptation, *IEEE Signal Processing Letters* 23 (4) (2016) 551–555. doi:[10.1109/LSP.2016.2539328](https://doi.org/10.1109/LSP.2016.2539328).

- [113] P. Clarke, R. C. de Lamare, Low-complexity reduced-rank linear interference suppression based on set-membership joint iterative optimization for ds-cdma systems, *IEEE Transactions on Vehicular Technology* 60 (9) (2011) 4324–4337. doi:10.1109/TVT.2011.2171376.
- [114] S. Li, R. C. de Lamare, R. Fa, Reduced-rank linear interference suppression for ds-uwfb systems based on switched approximations of adaptive basis functions, *IEEE Transactions on Vehicular Technology* 60 (2) (2011) 485–497. doi:10.1109/TVT.2010.2090545.
- [115] F. G. Almeida Neto, R. C. De Lamare, V. H. Nascimento, Y. V. Zakharov, Adaptive reweighting homotopy algorithms applied to beamforming, *IEEE Transactions on Aerospace and Electronic Systems* 51 (3) (2015) 1902–1915. doi:10.1109/TAES.2015.140401.
- [116] W. S. Leite, R. C. De Lamare, List-based omp and an enhanced model for doa estimation with non-uniform arrays, *IEEE Transactions on Aerospace and Electronic Systems* (2021) 1–1doi:10.1109/TAES.2021.3087836.
- [117] T. Wang, R. C. de Lamare, A. Schmeink, Joint linear receiver design and power allocation using alternating optimization algorithms for wireless sensor networks, *IEEE Transactions on Vehicular Technology* 61 (9) (2012) 4129–4141. doi:10.1109/TVT.2012.2212217.
- [118] R. C. de Lamare, P. S. R. Diniz, Blind adaptive interference suppression based on set-membership constrained constant-modulus algorithms with dynamic bounds, *IEEE Transactions on Signal Processing* 61 (5) (2013) 1288–1301. doi:10.1109/TSP.2012.2229995.
- [119] Y. Cai, R. C. de Lamare, Low-complexity variable step-size mechanism for code-constrained constant modulus stochastic gradient algorithms applied to cdma interference suppression, *IEEE Transactions on Signal Processing* 57 (1) (2009) 313–323. doi:10.1109/TSP.2008.2005861.
- [120] Y. Cai, R. C. de Lamare, M. Zhao, J. Zhong, Low-complexity variable forgetting factor mechanism for blind adaptive constrained constant modulus algorithms, *IEEE Transactions on Signal Processing* 60 (8) (2012) 3988–4002. doi:10.1109/TSP.2012.2199317.
- [121] M. F. Kaloorazi, R. C. de Lamare, Subspace-orbit randomized decomposition for low-rank matrix approximations, *IEEE Transactions on Signal Processing* 66 (16) (2018) 4409–4424. doi:10.1109/TSP.2018.2853137.

- [122] R. B. Di Renna, R. C. de Lamare, Adaptive activity-aware iterative detection for massive machine-type communications, *IEEE Wireless Communications Letters* 8 (6) (2019) 1631–1634. doi:10.1109/LWC.2019.2932674.
- [123] H. Ruan, R. C. de Lamare, Distributed robust beamforming based on low-rank and cross-correlation techniques: Design and analysis, *IEEE Transactions on Signal Processing* 67 (24) (2019) 6411–6423. doi:10.1109/TSP.2019.2954519.
- [124] S. F. B. Pinto, R. C. de Lamare, Multistep knowledge-aided iterative esprit: Design and analysis, *IEEE Transactions on Aerospace and Electronic Systems* 54 (5) (2018) 2189–2201. doi:10.1109/TAES.2018.2811098.
- [125] Y. V. Zakharov, V. H. Nascimento, R. C. De Lamare, F. G. De Almeida Neto, Low-complexity dcd-based sparse recovery algorithms, *IEEE Access* 5 (2017) 12737–12750. doi:10.1109/ACCESS.2017.2715882.
- [126]
- [127] S. Li, R. C. de Lamare, Blind reduced-rank adaptive receivers for ds-ubw systems based on joint iterative optimization and the constrained constant modulus criterion, *IEEE Transactions on Vehicular Technology* 60 (6) (2011) 2505–2518. doi:10.1109/TVT.2011.2157844.
- [128] X. Wu, Y. Cai, M. Zhao, R. C. de Lamare, B. Champagne, Adaptive widely linear constrained constant modulus reduced-rank beamforming, *IEEE Transactions on Aerospace and Electronic Systems* 53 (1) (2017) 477–492. doi:10.1109/TAES.2017.2650838.
- [129] Y. Yu, H. He, T. Yang, X. Wang, R. C. de Lamare, Diffusion normalized least mean m-estimate algorithms: Design and performance analysis, *IEEE Transactions on Signal Processing* 68 (2020) 2199–2214. doi:10.1109/TSP.2020.2983905.
- [130] R. B. Di Renna, R. C. de Lamare, Iterative list detection and decoding for massive machine-type communications, *IEEE Transactions on Communications* 68 (10) (2020) 6276–6288. doi:10.1109/TCOMM.2020.3007525.
- [131] L. Wang, Set-membership constrained conjugate gradient adaptive algorithm for beamforming, *IET Signal Processing* 6 (2012) 789–797(8).
URL <https://digital-library.theiet.org/content/journals/10.1049/iet-spr.2011.0324>

- [132] P. Li, R. C. de Lamare, R. Fa, Multiple feedback successive interference cancellation detection for multiuser mimo systems, *IEEE Transactions on Wireless Communications* 10 (8) (2011) 2434–2439. doi:10.1109/TWC.2011.060811.101962.
- [133] S. F. B. Pinto, R. C. de Lamare, Block diagonalization precoding and power allocation for multiple-antenna systems with coarsely quantized signals, *IEEE Transactions on Communications* 69 (10) (2021) 6793–6807. doi:10.1109/TCOMM.2021.3096557.
- [134] V. M. T. Palhares, A. R. Flores, R. C. de Lamare, Robust mmse precoding and power allocation for cell-free massive mimo systems, *IEEE Transactions on Vehicular Technology* 70 (5) (2021) 5115–5120. doi:10.1109/TVT.2021.3072828.
- [135] A. R. Flores, R. C. De Lamare, B. Clerckx, Tomlinson-harashima precoded rate-splitting with stream combiners for mu-mimo systems, *IEEE Transactions on Communications* 69 (6) (2021) 3833–3845. doi:10.1109/TCOMM.2021.3065145.
- [136] R. B. D. Renna, R. C. de Lamare, Dynamic message scheduling based on activity-aware residual belief propagation for asynchronous mmhc, *IEEE Wireless Communications Letters* 10 (6) (2021) 1290–1294. doi:10.1109/LWC.2021.3064304.
- [137] Z. Shao, L. T. N. Landau, R. C. de Lamare, Dynamic oversampling for 1-bit adcs in large-scale multiple-antenna systems, *IEEE Transactions on Communications* 69 (5) (2021) 3423–3435. doi:10.1109/TCOMM.2021.3059303.
- [138] A. Danaee, R. C. de Lamare, V. H. Nascimento, Energy-efficient distributed learning with coarsely quantized signals, *IEEE Signal Processing Letters* 28 (2021) 329–333. doi:10.1109/LSP.2021.3051522.
- [139] R. B. Di Renna, C. Bockelmann, R. C. de Lamare, A. Dekorsy, Detection techniques for massive machine-type communications: Challenges and solutions, *IEEE Access* 8 (2020) 180928–180954. doi:10.1109/ACCESS.2020.3027523.
- [140] Z. Shao, L. T. N. Landau, R. C. De Lamare, Channel estimation for large-scale multiple-antenna systems using 1-bit adcs and oversampling, *IEEE Access* 8 (2020) 85243–85256. doi:10.1109/ACCESS.2020.2992246.

- [141] F. L. Duarte, R. C. de Lamare, Cloud-driven multi-way multiple-antenna relay systems: Joint detection, best-user-link selection and analysis, *IEEE Transactions on Communications* 68 (6) (2020) 3342–3354. doi:10.1109/TCOMM.2020.2978191.
- [142] Y. Yu, H. He, T. Yang, X. Wang, R. C. de Lamare, Diffusion normalized least mean m-estimate algorithms: Design and performance analysis, *IEEE Transactions on Signal Processing* 68 (2020) 2199–2214. doi:10.1109/TSP.2020.2983905.
- [143] A. R. Flores, R. C. de Lamare, B. Clerckx, Linear precoding and stream combining for rate splitting in multiuser mimo systems, *IEEE Communications Letters* 24 (4) (2020) 890–894. doi:10.1109/LCOMM.2020.2969158.
- [144] X. Wang, Z. Yang, J. Huang, R. C. de Lamare, Robust two-stage reduced-dimension sparsity-aware stap for airborne radar with coprime arrays, *IEEE Transactions on Signal Processing* 68 (2020) 81–96. doi:10.1109/TSP.2019.2957640.
- [145] Y. Yu, H. Zhao, R. C. de Lamare, Y. Zakharov, L. Lu, Robust distributed diffusion recursive least squares algorithms with side information for adaptive networks, *IEEE Transactions on Signal Processing* 67 (6) (2019) 1566–1581. doi:10.1109/TSP.2019.2893846.
- [146] P. M. Vieting, R. C. de Lamare, L. Martin, G. Dartmann, A. Schmeink, Likelihood-based adaptive learning in stochastic state-based models, *IEEE Signal Processing Letters* 26 (7) (2019) 1031–1035. doi:10.1109/LSP.2019.2917495.
- [147] W. Zhang, R. C. de Lamare, C. Pan, M. Chen, J. Dai, B. Wu, X. Bao, Widely linear precoding for large-scale mimo with iqi: Algorithms and performance analysis, *IEEE Transactions on Wireless Communications* 16 (5) (2017) 3298–3312. doi:10.1109/TWC.2017.2679706.
- [148] Y. Cai, R. C. de Lamare, B. Champagne, B. Qin, M. Zhao, Adaptive reduced-rank receive processing based on minimum symbol-error-rate criterion for large-scale multiple-antenna systems, *IEEE Transactions on Communications* 63 (11) (2015) 4185–4201. doi:10.1109/TCOMM.2015.2475260.
- [149] D. Delvecchio, L. Piroddi, A dual filtering scheme for nonlinear active noise control, *Int. J. Adapt. Control Signal Process.* 28 (12) (2014) 1422–1439.

- [150] R. Srazhidinov, R. Kamil, S. B. M. Noor, NLFXLMS and THF-NLFXLMS algorithms for Wiener-Hammerstein nonlinear active noise control, *Asian J. Control* 19 (5) (2017) 1791–1801.
- [151] P. V. Kumar, K. M. M. Prabhu, D. P. Das, Block filtered-s least mean square algorithm for active control of non-linear noise systems, *IET Signal Process.* 4 (2) (2010) 168–180.
- [152] M. Bergamasco, F. Della Rossa, L. Piroddi, Active noise control with on-line estimation of non-Gaussian noise characteristics, *J. Sound Vib.* 331 (1) (2012) 27–40.
- [153] K.-L. Yin, H. Zhao, L. Lu, Functional link artificial neural network filter based on the q -gradient for nonlinear active noise control, *J. Sound and Vib.* 435 (2018) 205–217.
- [154] L. Luo, Z. Bai, W. Zhu, J. Sun, Improved functional link artificial neural network filters for nonlinear active noise control, *Appl. Acoust.* 135 (2018) 111–123.
- [155] D. C. Le, J. Zhang, D. Li, Hierarchical partial update generalized functional link artificial neural network filter for nonlinear active noise control, *Digit. Signal Process.* 93 (2019) 160–171.
- [156] V. Patel, V. Gandhi, S. Heda, N. V. George, Design of adaptive exponential functional link network-based nonlinear filters, *IEEE Trans. Circuits Syst. I* 63 (9) (2016) 1434–1442.
- [157] D. C. Le, J. Zhang, D. Li, S. Zhang, A generalized exponential functional link artificial neural networks filter with channel-reduced diagonal structure for nonlinear active noise control, *Appl. Acoust.* 139 (2018) 174–181.
- [158] T. Deb, D. Ray, N. V. George, Design of nonlinear filters using affine projection algorithm based exact and approximate adaptive exponential functional link networks, *IEEE Trans. Circuits Syst. II*, 10.1109/TCSII.2019.2962916.
- [159] N. V. George, G. Panda, On the development of adaptive hybrid active noise control system for effective mitigation of nonlinear noise, *Signal Process.* 92 (2) (2012) 509–516.
- [160] G. L. Sicuranza, A. Carini, On the BIBO stability condition of adaptive recursive FLANN filters with application to nonlinear active noise control, *IEEE Trans. Audio Speech Lang. Process.* 20 (1) (2012) 234–245.

- [161] G. L. Sicuranza, A. Carini, A new recursive controller for nonlinear active noise control, in: Proc. Int. Symp. Image Signal Process. Anal., 2013, pp. 633–638.
- [162] A. Carini, G. L. Sicuranza, Fourier nonlinear filters, *Signal Process.* 94 (2014) 183–194.
- [163] X. Guo, J. Jiang, L. Tan, S. Du, Improved adaptive recursive even mirror Fourier nonlinear filter for nonlinear active noise control, *Appl. Acoust.* 146 (2019) 310–319.
- [164] X. Guo, Y. Li, J. Jiang, C. Dong, S. Du, L. Tan, Sparse modeling of nonlinear secondary path for nonlinear active noise control, *IEEE Trans. Instrum. Meas.* 67 (3) (2018) 482–496.
- [165] L. Tan, J. Jiang, Nonlinear active noise control using diagonal-channel LMS and RLS bilinear filters, in: Proc. IEEE Int. Midwest Symp. Circuits Syst., 2014, pp. 789–792.
- [166] X. Guo, J. Jiang, J. Chen, S. Du, L. Tan, BIBO-stable implementation of adaptive function expansion bilinear filter for nonlinear active noise control, *Appl. Acoust.* 168 (2020) 107407.
- [167] C. Dong, Y. Ding, L. Tan, S. Du, X. Guo, Diagonal-structure adaptive bilinear filters for multichannel active noise control of nonlinear noise processes, *Mechan. Syst. Signal Process.* 143 (2020) 106703.
- [168] L. Tan, C. Dong, S. Du, On implementation of adaptive bilinear filters for nonlinear active noise control, *Appl. Acoust.* 106 (2016) 122–128.
- [169] L. Zhu, T. Yang, J. Pan, M. Zhu, X. Li, Reweighted adaptive bilinear filters for an active noise control system with a nonlinear secondary path, *Appl. Acoust.* 155 (2019) 123–129.
- [170] L. Luo, J. Sun, A novel bilinear functional link neural network filter for nonlinear active noise control, *Appl. Soft Comput.* 68 (2018) 636–650.
- [171] E. Spiriti, S. Morici, L. Piroddi, A gradient-free adaptation method for nonlinear active noise control, *J. Sound Vib.* 333 (1) (2014) 13–30.
- [172] D. P. Das, D. J. Moreau, B. S. Cazzolato, Adjoint nonlinear active noise control algorithm for virtual microphone, *Mech. Syst. Signal Process.* 27 (2012) 743–754.
- [173] N. V. George, A. Gonzalez, Convex combination of nonlinear adaptive filters for active noise control, *Appl. Acoust.* 76 (2014) 157–161.

- [174] N. C. Kurian, K. Patel, N. V. George, Robust active noise control: An information theoretic learning approach, *Appl. Acoust.* 117 (2017) 180–184.
- [175] S. K. Behera, D. P. Das, B. Subudhi, Functional link artificial neural network applied to active noise control of a mixture of tonal and chaotic noise, *Appl. Soft Comput.* 23 (2014) 51–60.
- [176] X. Guo, J. Jiang, J. Chen, S. Du, L. Tan, Convex combination recursive even mirror Fourier nonlinear filter for nonlinear active noise control, in: *Proc. Int. Conf. Electr. Mach. Syst.*, 2019, pp. 1–6.
- [177] L. Luo, J. Sun, B. Huang, A novel feedback active noise control for broadband chaotic noise and random noise, *Appl. Acoust.* 116 (2017) 229–237.
- [178] C.-Y. Chang, D.-R. Chen, Active noise cancellation without secondary path identification by using an adaptive genetic algorithm, *IEEE Trans. Instrum. Meas.* 59 (9) (2010) 2315–2327.
- [179] M. A. Z. Raja, M. S. Aslam, N. I. Chaudhary, W. U. Khan, Bio-inspired heuristics hybrid with interior-point method for active noise control systems without identification of secondary path, *Front. Inform. Technol. Electron. Eng.* 19 (2) (2018) 246–259.
- [180] W. U. Khan, Z. Ye, N. I. Chaudhary, M. A. Z. Raja, Backtracking search integrated with sequential quadratic programming for nonlinear active noise control systems, *Appl. Soft Comput.* 73 (2018) 666–683.
- [181] M. A. Z. Raja, M. S. Aslam, N. I. Chaudhary, M. Nawaz, S. M. Shah, Design of hybrid nature-inspired heuristics with application to active noise control systems, *Neural Comput. Applic.* 31 (7) (2019) 2563–2591.
- [182] N. V. George, G. Panda, A particle-swarm-optimization-based decentralized nonlinear active noise control system, *IEEE Trans. Instrum. Meas.* 61 (12) (2012) 3378–3386.
- [183] N. V. George, G. Panda, A robust evolutionary feedforward active noise control system using Wilcoxon norm and particle swarm optimization algorithm, *Expert Syst. Appl.* 39 (8) (2012) 7574–7580.

- [184] S. Gholami-Boroujeny, M. Eshghi, Non-linear active noise cancellation using a bacterial foraging optimisation algorithm, *IET Signal Process.* 6 (4) (2012) 364–373.
- [185] S. Gholami-Boroujeny, M. Eshghi, Active noise control using an adaptive bacterial foraging optimization algorithm, *Signal, Image Video Process.* 8 (8) (2014) 1507–1516.
- [186] R. Walia, S. Ghosh, Design of active noise control system using hybrid functional link artificial neural network and finite impulse response filters, *Neural Comput. Appl.* (2018) 1–10.
- [187] V. Patel, N. V. George, Nonlinear active noise control using spline adaptive filters, *Appl. Acoust.* 93 (2015) 38–43.
- [188] V. Patel, N. V. George, Multi-channel spline adaptive filters for non-linear active noise control, *Appl. Acoust.* 161 (2020) 107142.
- [189] V. Patel, D. Comminiello, M. Scarpiniti, N. V. George, A. Uncini, Design of hybrid nonlinear spline adaptive filters for active noise control, in: *Proc. Int. Joint Conf. Neural Netw.*, 2016, pp. 3420–3425.
- [190] Y. Liu, C. Sun, S. Jiang, Kernel filtered-x LMS algorithm for active noise control system with nonlinear primary path, *Circuits Syst., Signal Process.* 37 (12) (2018) 5576–5594.
- [191] M. A. Z. Raja, N. I. Chaudhary, Z. Ahmed, A. U. Rehman, M. S. Aslam, A novel application of kernel adaptive filtering algorithms for attenuation of noise interferences, *Neural Comput. Appl.* 31 (12) (2019) 9221–9240.
- [192] R. Kukde, M. S. Manikandan, G. Panda, Incremental learning based adaptive filter for non-linear distributed active noise control system, *IEEE Open J. Signal Process.* 1 (2020) 1–13.
- [193] S. E. Craig, O. L. Angevine, Active control of hum from large power transformers-the real world, in: *Proc. Recent Advances in Active Control of Sound Vibration*, 1993, pp. 279–290.
- [194] T. J. Sutton, S. J. Elliott, A. M. McDonald, T. J. Saunders, Active control of road noise inside vehicles, *Noise Control Eng. J.* 42 (4) (1994) 137–147.
- [195] M. McJury, R. Stewart, D. Crawford, E. Toma, The use of active noise control (ANC) to reduce acoustic noise generated during MRI scanning: some initial results, *Magn. Reson. Imaging* 15 (3) (1997) 319–322.

- [196] W. S. Gan, S. M. Kuo, An integrated audio and active noise control headset, *IEEE Trans. Consum. Electron.* 48 (2) (2002) 242–247.
- [197] X. Qiu, X. Li, Y. Ai, C. H. Hansen, A waveform synthesis algorithm for active control of transformer noise: implementation, *Appl. Acoust.* 63 (5) (2002) 467–479.
- [198] A. Jakob, M. Möser, Active control of double-glazed windows Part I: Feedforward control, *Appl. Acoust.* 64 (2) (2003) 163–182.
- [199] A. Jakob, M. Möser, Active control of double-glazed windows Part II: Feedback control, *Appl. Acoust.* 64 (2) (2003) 183–196.
- [200] G. Pinte, W. Desmet, P. Sas, Active control of impact noise in a duct, in: *Proc. Int. Conf. Sound Vib.*, 2003, pp. 3727–3734.
- [201] Y.-L. Zhou, Q.-Z. Zhang, X.-D. Li, W.-S. Gan, Analysis and DSP implementation of an ANC system using a filtered-error neural network, *J. Sound Vib.* 285 (1-2) (2005) 1–25.
- [202] S. M. Kuo, S. Mitra, W.-S. Gan, Active noise control system for headphone applications, *IEEE Trans. Control Syst. Technol.* 14 (2) (2006) 331–335.
- [203] C.-Y. Chang, Efficient active noise controller using a fixed-point DSP, *Signal Process.* 89 (5) (2009) 843–850.
- [204] C. Kim, C. Jong, X. Zhang, P. Wang, J. Kim, Enhancement of noise reduction efficiency based on compensation in the ANC headset using fixed-point DSP, *Appl. Acoust.* 116 (2017) 271–282.
- [205] B. Siravara, M. Mansour, R. Cole, N. Magotra, Comparative study of wideband single reference active noise cancellation algorithms on a fixed-point DSP, in: *Proc. IEEE Int. Conf. Acoust., Speech, Signal Process.*, Vol. 2, 2003, pp. 473–476.
- [206] I. T. Ardekani, W. H. Abdulla, Filtered weight FxLMS adaptation algorithm: Analysis, design and implementation, *Int. J. Adapt. Control Signal Process.* 25 (11) (2011) 1023–1037.
- [207] D. Shi, J. He, C. Shi, T. Murao, W.-S. Gan, Multiple parallel branch with folding architecture for multichannel filtered-x least mean square algorithm, in: *Proc. IEEE Int. Conf. Acoust., Speech Signal Process.*, 2017, pp. 1188–1192.

- [208] A. Leva, L. Piroddi, FPGA-based implementation of high-speed active noise and vibration controllers, *Control Eng. Pract.* 19 (8) (2011) 798–808.
- [209] B. K. Mohanty, G. Singh, G. Panda, Hardware design for VLSI implementation of FxLMS-and FsLMS-based active noise controllers, *Circuits, Syst., Signal Process.* 36 (2) (2017) 447–473.
- [210] B. Kwon, Y. Park, Interior noise control with an active window system, *Appl. Acoust.* 74 (5) (2013) 647–652.
- [211] H. Huang, X. Qiu, J. Kang, Active noise attenuation in ventilation windows, *J. Acoust. Soc. Amer.* 130 (1) (2011) 176–188.
- [212] S. Wang, J. Tao, X. Qiu, J. Pan, A boundary error sensing arrangement for virtual sound barriers to reduce noise radiation through openings, *J. Acoust. Soc. Amer.* 145 (6) (2019) 3695–3702.
- [213] K. Wang, J. Tao, X. Qiu, Boundary control of sound transmission into a cavity through its opening, *J. Sound Vib.* 442 (2019) 350–365.
- [214] T. Murao, M. Nishimura, W.-S. Gan, A hybrid approach to active and passive noise control for open windows, *Appl. Acoust.* 155 (2019) 338–345.
- [215] B. Lam, C. Shi, D. Shi, W.-S. Gan, Active control of sound through full-sized open windows, *Build. Environ.* 141 (2018) 16–27.
- [216] B. Lam, S. Elliott, J. Cheer, W.-S. Gan, Physical limits on the performance of active noise control through open windows, *Appl. Acoust.* 137 (2018) 9–17.
- [217] S. J. Elliott, J. Cheer, L. Bhan, C. Shi, W.-S. Gan, A wavenumber approach to analysing the active control of plane waves with arrays of secondary sources, *J. Sound Vib.* 419 (2018) 405–419.
- [218] C. Zhang, M. Qin, H. Zou, X. Qiu, Secondary source and error sensing strategies for the active control of sound transmission through a small opening, *J. Sound Vib.* 464 (2020) 114973.
- [219] T. Murao, C. Shi, W.-S. Gan, M. Nishimura, Mixed-error approach for multi-channel active noise control of open windows, *Appl. Acoust.* 127 (2017) 305–315.

- [220] H.-S. Vu, K.-H. Chen, A low-power broad-bandwidth noise cancellation VLSI circuit design for in-ear headphones, *IEEE Trans. VLSI Syst.* 24 (6) (2016) 2013–2025.
- [221] W. Jung, S. J. Elliott, J. Cheer, Combining the remote microphone technique with head-tracking for local active sound control, *J. Acoust. Soc. Amer.* 142 (1) (2017) 298–307.
- [222] S. K. Behera, D. P. Das, B. Subudhi, Head movement immune active noise control with head mounted moving microphones, *J. Acoust. Soc. Amer.* 142 (2) (2017) 573–587.
- [223] J. Cheer, V. Patel, S. Fontana, The application of a multi-reference control strategy to noise cancelling headphones, *J. Acoust. Soc. Amer.* 145 (5) (2019) 3095–3103.
- [224] C.-Y. Chang, S.-T. Li, Active noise control in headsets by using a low-cost microcontroller, *IEEE Trans. Ind. Electron.* 58 (5) (2011) 1936–1942.
- [225] L. Zhang, L. Wu, X. Qiu, An intuitive approach for feedback active noise controller design, *Appl. Acoust.* 74 (1) (2013) 160–168.
- [226] H.-S. Vu, K.-H. Chen, A high-performance feedback FxLMS active noise cancellation VLSI circuit design for in-ear headphones, *Circuits, Syst., Signal Process.* 36 (7) (2017) 2767–2785.
- [227] T. Schumacher, H. Krüger, M. Jeub, P. Vary, C. Beaugeant, Active noise control in headsets: A new approach for broadband feedback ANC, in: *Proc. IEEE Int. Conf. Acoust., Speech Signal Process.*, 2011, pp. 417–420.
- [228] K. Tanaka, C. Shi, Y. Kajikawa, Binaural active noise control using parametric array loudspeakers, *Appl. Acoust.* 116 (2017) 170–176.
- [229] N. Tanaka, M. Tanaka, Active noise control using a steerable parametric array loudspeaker, *J. Acoust. Soc. Amer.* 127 (6) (2010) 3526–3537.
- [230] N. Tanaka, M. Tanaka, Mathematically trivial control of sound using a parametric beam focusing source, *J. Acoust. Soc. Amer.* 129 (1) (2011) 165–172.
- [231] V. Belyi, W.-S. Gan, A combined bilateral and binaural active noise control algorithm for closed-back headphones, *Appl. Acoust.* 160 (2020) 107129.

- [232] D. P. Das, D. J. Moreau, B. S. Cazzolato, Nonlinear active noise control for headrest using virtual microphone control, *Control Eng. Pract.* 21 (4) (2013) 544–555.
- [233] M. Guldenschuh, R. Höldrich, Prediction filter design for active noise cancellation headphones, *IET Signal Process.* 7 (6) (2013) 497–504.
- [234] B. Rafaely, Spherical loudspeaker array for local active control of sound, *J. Acoust. Soc. Amer.* 125 (5) (2009) 3006–3017.
- [235] T. Peleg, B. Rafaely, Investigation of spherical loudspeaker arrays for local active control of sound, *J. Acoust. Soc. Amer.* 130 (4) (2011) 1926–1935.
- [236] C. R. Hart, S.-K. Lau, Active noise control with linear control source and sensor arrays for a noise barrier, *J. Sound Vib.* 331 (1) (2012) 15–26.
- [237] S. J. Elliott, J. Cheer, Modeling local active sound control with remote sensors in spatially random pressure fields, *J. Acoust. Soc. Amer.* 137 (4) (2015) 1936–1946.
- [238] W.-K. Tseng, Local active noise control using a novel method of designing quiet zones, *Control Eng. Pract.* 19 (12) (2011) 1450–1458.
- [239] I. T. Ardekani, W. H. Abdulla, Adaptive signal processing algorithms for creating spatial zones of quiet, *Digit. Signal Process.* 27 (2014) 129–139.
- [240] S. Wrona, M. de Diego, M. Pawelczyk, Shaping zones of quiet in a large enclosure generated by an active noise control system, *Control Eng. Pract.* 80 (2018) 1–16.
- [241] R. Serizel, M. Moonen, J. Wouters, S. H. Jensen, A zone of quiet based approach to integrated active noise control and noise reduction in hearing aids, in: *Proc. IEEE Int. Conf. Acoust., Speech Signal Process.*, 2009, pp. 229–232.
- [242] R. Serizel, M. Moonen, J. Wouters, S. H. Jensen, A zone-of-quiet based approach to integrated active noise control and noise reduction for speech enhancement in hearing aids, *IEEE Trans. Audio, Speech, Lang. Process.* 20 (6) (2012) 1685–1697.
- [243] R. Serizel, M. Moonen, J. Wouters, S. H. Jensen, Integrated active noise control and noise reduction in hearing aids, *IEEE Trans. Audio, Speech, Lang. Process.* 18 (6) (2009) 1137–1146.

- [244] S. Pradhan, S. S. Bhattacharjee, V. Patel, N. V. George, Speech enhancement in digital hearing aids: an active noise control approach, in: Proc. ICSV, 2017, pp. 1–8.
- [245] F. Albu, An efficient combined active noise control and noise reduction method for hearing aids, in: Proc. Euronoise, 2018, pp. 915–919.
- [246] J. Zhang, T. D. Abhayapala, P. N. Samarasinghe, W. Zhang, S. Jiang, Sparse complex FxLMS for active noise cancellation over spatial regions, in: Proc. IEEE Int. Conf. Acoust. Speech Signal Process., 2016, pp. 524–528.
- [247] J. Zhang, T. D. Abhayapala, W. Zhang, P. N. Samarasinghe, S. Jiang, Active noise control over space: A wave domain approach, *IEEE/ACM Trans. Audio, Speech, Lang. Process.* 26 (4) (2018) 774–786.
- [248] W. Zhang, C. Hofmann, M. Buerger, T. D. Abhayapala, W. Kellermann, Spatial noise-field control with online secondary path modeling: A wave-domain approach, *IEEE/ACM Trans. Audio, Speech, Lang. Process.* 26 (12) (2018) 2355–2370.
- [249] Y. Maeno, Y. Mitsufuji, T. D. Abhayapala, Mode domain spatial active noise control using sparse signal representation, in: Proc. IEEE Int. Conf. Acoust. Speech Signal Process., 2018, pp. 211–215.
- [250] N. Murata, J. Zhang, Y. Maeno, Y. Mitsufuji, Global and local mode-domain adaptive algorithms for spatial active noise control using higher-order sources, in: Proc. IEEE Int. Conf. Acoust. Speech Signal Process., 2019, pp. 526–530.
- [251] M. Kumamoto, M. Kida, R. Hirayama, Y. Kajikawa, T. Tani, Y. Kurumi, Active noise control system for reducing MR noise, *IEICE Trans. Fundamentals* 94 (7) (2011) 1479–1486.
- [252] G. Kannan, A. A. Milani, I. M. Panahi, R. W. Briggs, An efficient feedback active noise control algorithm based on reduced-order linear predictive modeling of fMRI acoustic noise, *IEEE Trans. Biomed. Eng.* 58 (12) (2011) 3303–3309.
- [253] M. Kida, R. Hirayama, Y. Kajikawa, T. Tani, Y. Kurumi, Head-mounted active noise control system for MR noise, in: Proc. IEEE Int. Conf. Acoust. Speech Signal Process., 2009, pp. 245–248.

- [254] N. Miyazaki, Y. Kajikawa, Head-mounted active noise control system with virtual sensing technique, *J. Sound Vib.* 339 (2015) 65–83.
- [255] A. Ganguly, C. K. Reddy, I. Panahi, Improved parallel feedback active noise control using linear prediction for adaptive noise decomposition, in: *Proc. IEEE Int. Conf. Acoust. Speech Signal Process.*, 2015, pp. 664–668.
- [256] M. Niedźwiecki, M. Meller, A new approach to active noise and vibration control—Part I: The known frequency case, *IEEE Trans. Signal Process.* 57 (9) (2009) 3373–3386.
- [257] M. Niedźwiecki, M. Meller, A new approach to active noise and vibration control—Part II: The unknown frequency case, *IEEE Trans. Signal Process.* 57 (9) (2009) 3387–3398.
- [258] M. Niedźwiecki, M. Meller, Self-optimizing adaptive vibration controller, *IEEE Trans. Automat. Contr.* 54 (9) (2009) 2087–2099.
- [259] M. Niedźwiecki, M. Meller, Y. Kajikawa, D. Łukwiński, Estimation of nonstationary harmonic signals and its application to active control of MRI noise, in: *Proc. IEEE Int. Conf. Acoust. Speech Signal Process.*, 2013, pp. 5661–5665.
- [260] N. Lee, Y. Park, G. W. Lee, Frequency-domain active noise control for magnetic resonance imaging acoustic noise, *Appl. Acoust.* 118 (2017) 30–38.
- [261] Y. Zhou, Y. Yin, Q. Zhang, An optimal repetitive control algorithm for periodic impulsive noise attenuation in a non-minimum phase ANC system, *Appl. Acoust.* 74 (10) (2013) 1175–1181.
- [262] G. Sun, T. Feng, M. Li, T. C. Lim, Convergence analysis of FxLMS-based active noise control for repetitive impulses, *Appl. Acoust.* 89 (2015) 178–187.
- [263] G. Pinte, B. Stallaert, P. Sas, W. Desmet, J. Swevers, A novel design strategy for iterative learning and repetitive controllers of systems with a high modal density: Theoretical background, *Mech. Syst. Signal Process.* 24 (2) (2010) 432–443.
- [264] B. Stallaert, G. Pinte, P. Sas, W. Desmet, J. Swevers, A novel design strategy for iterative learning and repetitive controllers of systems with a high modal density: Application to active noise control, *Mech. Syst. Signal Process.* 24 (2) (2010) 444–454.

- [265] Y. Zhou, Y. Yin, Q. Zhang, Active control of repetitive impulsive noise in a non-minimum phase system using an optimal iterative learning control algorithm, *J. Sound Vib.* 332 (18) (2013) 4089–4102.
- [266] T. Zhao, J. Liang, L. Zou, L. Zhang, A new FXLMS algorithm with offline and online secondary-path modeling scheme for active noise control of power transformers, *IEEE Trans. Ind. Electron.* 64 (8) (2017) 6432–6442.
- [267] P. N. Samarasinghe, W. Zhang, T. D. Abhayapala, Recent advances in active noise control inside automobile cabins: Toward quieter cars, *IEEE Signal Process. Mag.* 33 (6) (2016) 61–73.
- [268] S. J. Elliott, Active noise and vibration control in vehicles, in: *Vehicle Noise and Vibration Refinement*, Elsevier, 2010, pp. 235–251.
- [269] J. Cheer, Active control of the acoustic environment in an automobile cabin, Ph.D. thesis, University of Southampton (2012).
- [270] J. Cheer, S. J. Elliott, The design and performance of feedback controllers for the attenuation of road noise in vehicles, *Int. J. Acoust. Vib.* 19 (3) (2014) 155–164.
- [271] J. Cheer, S. J. Elliott, Multichannel control systems for the attenuation of interior road noise in vehicles, *Mech. Syst. Signal Process.* 60 (2015) 753–769.
- [272] W. Jung, S. J. Elliott, J. Cheer, Local active control of road noise inside a vehicle, *Mech. Syst. Signal Process.* 121 (2019) 144–157.
- [273] H. Guo, Y. Wang, N. N. Liu, R. P. Yu, H. Chen, X. T. Liu, Active interior noise control for rail vehicle using a variable step-size median-LMS algorithm, *Mechan. Syst. Signal Process.* 109 (2018) 15–26.
- [274] J. Cheer, S. J. Elliott, Active noise control of a diesel generator in a luxury yacht, *Applied Acoustics* 105 (2016) 209–214.
- [275] P. Peretti, S. Cecchi, L. Romoli, F. Piazza, Adaptive feedback active noise control for yacht environments, *IEEE Trans. Control Syst. Technol.* 22 (2) (2013) 737–744.

- [276] J. Cheer, S. J. Elliott, E. Oh, J. Jeong, Application of the remote microphone method to active noise control in a mobile phone, *J. Acoust. Soc. Amer.* 143 (4) (2018) 2142–2151.
- [277] S.-P. Moon, J. W. Lee, T.-G. Chang, Performance analysis of an adaptive feedback active noise control based earmuffs system, *Appl. Acoust.* 96 (2015) 53–60.
- [278] L. Zhu, T. Yang, J. Pan, Design of nonlinear active noise control earmuffs for excessively high noise level, *J. Acoust. Soc. Amer.* 146 (3) (2019) 1547–1555.
- [279] I.-H. Yang, J.-E. Jeong, U.-C. Jeong, J.-S. Kim, J.-E. Oh, Improvement of noise reduction performance for a high-speed elevator using modified active noise control, *Appl. Acoust.* 79 (2014) 58–68.
- [280] S. R. Chen, G. J. Too, Simulations and experiments for hybrid noise control systems, *Appl. Acoust.* 70 (2) (2009) 247–255.
- [281] K. Mazur, S. Wrona, M. Pawelczyk, Active noise control for a washing machine, *Appl. Acoust.* 146 (2019) 89–95.
- [282] J. Rohlffing, P. Gardonio, Ventilation duct with concurrent acoustic feed-forward and decentralised structural feedback active control, *J. Sound Vib.* 333 (3) (2014) 630–645.
- [283] P. Gardonio, J. Rohlffing, Modular feed-forward active noise control units for ventilation ducts, *J. Acoust. Soc. Amer.* 136 (6) (2014) 3051–3062.
- [284] F. Ma, W. Zhang, T. D. Abhayapala, Active control of outgoing broadband noise fields in rooms, *IEEE/ACM Trans, Audio, Speech, and Lang. Process.* 28 (2020) 529–539.
- [285] S. Bagha, R. Tripathy, P. Nanda, C. Preetam, D. P. Das, Understanding perception of active noise control system through multichannel EEG analysis, *IET Healthcare Technol. Lett.* 5 (3) (2018) 101–106.
- [286] S. K. Behera, D. P. Das, B. Subudhi, Adaptive nonlinear active noise control algorithm for active headrest with moving error microphones, *Appl. Acoust.* 123 (2017) 9–19.
- [287] N. Krishnamurthy, M. Mansour, R. Cole, Implementation challenges for feedback active noise cancellation, in: *Proc. IEEE Int. Conf. Acoust., Speech Signal Process.*, 2012, pp. 1649–1652.

- [288] M. Zeller, L. A. Azpicueta-Ruiz, J. A. García, W. Kellermann, Adaptive Volterra filters with evolutionary quadratic kernels using a combination scheme for memory control, *IEEE Trans. Signal Process.* 59 (4) (2010) 1449–1464.