

LIGHTWEIGHT DYNAMIC FILTER FOR KEYWORD SPOTTING

Donghyeon Kim¹, Kyungdeuk Ko¹, Jeong-gi Kwak¹, David K. Han², Hanseok Ko¹ *

¹School of Electrical Engineering, Korea University, Seoul, South Korea

²Department of Electrical and Computer Engineering, Drexel University, Philadelphia, PA USA

ABSTRACT

Keyword Spotting (KWS) from speech signal is widely applied for being fully hands free speech recognition. The KWS network is designed as a small footprint model to be constantly monitored. Recently, dynamic filter based models are applied in deep learning applications to enhance a system's robustness or accuracy. However, as a dynamic filter framework requires high computational cost, the usage is limited to the condition of the device. In this paper, we proposed a lightweight dynamic filter to improve the performance of KWS. Our proposed model divides dynamic filter as two branches to reduce the computational complexity. This lightweight dynamic filter is applied to the front-end of KWS to enhance the separability of the input data. The experiments show that our model is robustly working on unseen noise and small training data environment by using small computational resource.

Index Terms— Keyword spotting, Dynamic filter, Dynamic weight, Computational cost

1. INTRODUCTION

For smart devices on standby for human user's command, Keyword Spotting (KWS) is an essential capability. As these devices listen continuously to audio stream in the environment, its KWS process should cost minimally to conserve battery power. For this reason, model parameters and subsequent computational cost are important elements in evaluating KWS system. Conventional KWS has been based on Hidden Markov Models (HMMs) by using a vocabulary speech recognizer and a background model [1, 2]. With the advent of deep learning framework, Multi-Layer Perceptron (MLP) and Convolutional Neural Network (CNN) have been shown to outperform the conventional methods [3, 4]. Additionally, Convolutional Recurrent Neural Networks (CRNN) based models have been applied to combine the strengths of CNN and Recurrent Neural Network (RNN) [5]. As CNN requires high computations in general to extract spectral and temporal features, some proposed models focused to reduce computational cost. Depthwise Separable Convolution (DSCConv) extracts channel-wise features separately and later combines channel information by using 1D convolution [6]. As an alternative to low computational model, temporal convolution based networks [7, 8] have been proposed to extract spectral features by performing convolution on temporal axis. Neural Architecture Search (NAS) methods [9, 10] have been also proposed to find the best network structure with reduced computational requirement for KWS model. Although these networks would reduce memory footprints and computational operations, their performance have been shown to be limited, particularly with unknown speakers or unseen noise. An alternative to improve performance is by integrating a filter on the

front end of the process [11, 12]. In the conventional dynamic convolutional filter process, dynamic weights are generated by each input patch. Thus, computations need to be performed for all the input pixels. The added process of filtering results additional computational cost, thus, it defeats the intent of minimizing computations. For balancing the requirement of high performance and minimal computation, we propose a lightweight dynamic convolution for the front end filtering. In our proposed network, two branches of dynamic filters are implemented at the front end of the network. A pixel-level dynamic filter performs pixel attention for Time-Frequency features while an instance-level dynamic filter produces a global representative weight vector from temporal pooling of the acoustic features. These two weights are applied in a convolution process in computationally efficient manner to deliver dynamic filtering robust and adaptive to unknown audio input. The experimental results show that the proposed lightweight dynamic filter improves KWS performance with robustness over unseen noise. We further show that our model performance remains robust even when small sample training data was applied with low speaker diversity.

2. RELATED WORKS

Dynamic Filter Network (DFN) is an adaptive deep neural network architecture [11] that generates filter parameters by learning. DFN consists of a filter generator and dynamic filter layers. The filter generator produces weights of the neural network, and the process of filtering occurs in the dynamic filter layer with the generated weights. This method conditionally adjusts weight vectors for given patch-level features. This learning method is simpler and works more efficiently over self-attention network [13]. Kim *et al.* [12] proposed a convolution based dynamic filter network to enhance salient features from unseen noisy audio stream, and their experimental results showed that their approach outperformed over conventional feature enhancement methods. Fujita *et al.* [14] also utilized a dynamic filter based method for a light weight ASR model. They confirmed that applying dynamic convolution to the encoder-decoder network improves accuracy and reduces computational load over transformer [15] based models. Although dynamic filter based approaches have shown progressive performance improvements recently over other methods, they typically require high computational cost in filter implementation. To alleviate this issue, we borrow the idea of Decoupled Dynamic Filter (DDF) [16] from computer vision. Instead of a single filter to take up channel-spatial features directly, DDF divides the filtering into two parts: channel and spatial. The channel wise filter applies computationally efficient 1-D convolution while the spatial wise side uses a simple global average pooling. These two filters are trained at separate branches of the network and they are then combined into forming a dynamic filter for input feature maps. By using simple computations, this method yields significant reduction in memory and floating-point operations (FLOPs). In

*corresponding author

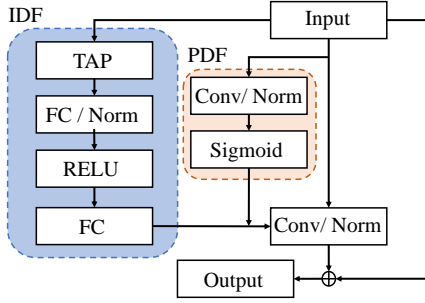

Fig. 1: Pipeline of Lightweight Dynamic Convolution process: PDF denotes Pixel Dynamic Filter; IDF denotes Instance-level Dynamic Filter.

our adaptation of DDF, we split the dynamic filter process into Pixel Dynamic Filter (PDF) and Instance-level Dynamic Filter (IDF). The PDF follows spatial attention mechanism to capture pixel saliency and the IDF determines direction of dynamic weight vector adaptive to input audio clip. The outputs of PDF and IDF are utilized to conduct the dynamic filter process.

3. LIGHTWEIGHTS DYNAMIC FILTER

As shown in Fig. 1, our proposed dynamic filter consists of Pixel Dynamic Filter (PDF) and Instance-level Dynamic Filter (IDF). The outputs of the two filters are multiplied to form the dynamic filter which is applied as convolutional kernels in carrying out the filtering process.

3.1. Pixel Dynamic Filter

The goal of PDF is obtaining attention based Time-Frequency (T-F) mask to measure saliency at pixel level. A single channel convolution is applied to T-F features ($x \in \mathbb{R}^{[N]}$, where $N = T \times F$), and normalization with sigmoid activation are subsequently applied for mapping the feature scale from 0 to 1. The process of PDF is as follows:

$$w_i^P = \rho(\text{Norm}(\text{Conv}(x_i, \mathbf{w}))), \quad (1)$$

where $\text{Conv}(\cdot)$ denotes the convolution process with x_i as the i 'th input data in mini-batch of the convolution and \mathbf{w} represents the training weights ($\mathbf{w} \in \mathbb{R}^{[K]}$, where K denotes size of convolution kernel). Then normalization with sigmoid activation ($\rho(\cdot)$) are performed in series to obtain pixel level weights ($w_i^P \in \mathbb{R}^{[N,1]}$).

3.2. Instance-level Dynamic Filter

Deep learning based conventional dynamic filters generate adaptive weights for the filter by carrying out full convolutional process. While this approach has shown to be flexible and adaptive in various domains of diverse speaker characteristics or noise, it comes at the cost of high computational loads. As an efficient alternative to the blind convolution based dynamic filter generation, we developed IDF which guides in capturing directional features of dynamic filter. IDF is aimed to produce an audio representative weight vector which is similar to speaker embedding in speaker verification. To this end, temporally averaged feature ($H \in \mathbb{R}^{[F]}$) which preserves frequency trait is fed to an MLP based model and the output is utilized as vector

Filter	Conv	DyConv	LDyConv
Parameter	K	K^2	$K(F+1)$
Time	$O(KN)$	$O(K^2N)$	$O(KN)$
Space	—	$O(KN)$	$O(N+K)$

Table 1: Comparison of the parameter numbers, computation time, and memory cost. Conv, DyConv, and LDyConv stand for static filter based convolution, Dynamic filter convolution, and Lightweight Dynamic convolution respectively.

direction of dynamic weight. The process of IDF is as follows:

$$\mathbf{w}^H = \max(0, \text{Norm}(H \cdot \mathbf{w}_1 + \mathbf{b}_1)) \cdot \mathbf{w}_2 + \mathbf{b}_2, \quad (2)$$

where \mathbf{w}_1 and \mathbf{b}_1 are learning parameters. Two layers of MLP with normalization and relu activation extract a weight vector ($\mathbf{w}^H \in \mathbb{R}^{[1,K]}$). In this way, the weight vector is generated uniquely per input audio signal, and the dynamic filters (\mathbf{w}^H and w_i^P) are conjugated for performing dynamic convolution.

3.3. Dynamic Convolution

The process of dynamic convolution is as follows:

$$\mathbf{w}_i^D = w_i^P \odot \mathbf{w}^H, \quad (3)$$

$$x_i^D = \text{Norm}(\text{Conv}(x_i, \mathbf{w}_i^D)), \quad (4)$$

$$x_i' = x_i^D + x_i, \quad (5)$$

where $\mathbf{w}_i^D \in \mathbb{R}^{[N,K]}$ denotes dynamic weights for CNN computation. From equation 3, weight vector (\mathbf{w}^H) and scalar weight of pixel (w_i^P) perform element-wised product (\odot) to obtain the dynamic weights. Then, convolution process using the dynamic weights is performed on the input and the result is normalized as in equation 4. Via skip connection, the normalized output ($x_i^D \in \mathbb{R}^{[N]}$) is added to the input x_i to be fed to KWS model as shown in equation 5. As such, dynamic convolution based filter generation adapts to each input effectively by enhancing features relevant to KWS task. In conventional dynamic filter, patch-level weight vector is produced by filter generator. Thus, weight vector has different direction and magnitude per each patch. Our method, however, produces a unit directional vector for all the patches while the magnitude is conditionally adjusted depending on each input patch. By decomposing the weight vector in terms of its direction and magnitude, dimensionality the weights can be reduced significantly. This would significantly reduce computational complexity of the dynamic filter.

3.4. Normalization process

We utilized two types of normalization process. Both normalization processes perform on zero mean unit variance (μ_x and σ_x) with trainable affine transform (α and β). In IDF, $x \in \mathbb{R}^{[F]}$ conducts mean/variance normalization to F axis and then $\alpha, \beta \in \mathbb{R}^{[F]}$ are applied for affine transform. In the other normalization process (PDF and dynamic convolution), $x \in \mathbb{R}^{[T,F]}$ conducts mean/variance normalization to T axis and then $\alpha, \beta \in \mathbb{R}^{[F]}$ are applied for affine transform.

3.5. Computational Complexity

Our proposed dynamic convolution is applied to the front-end of KWS network for the dynamic feature extraction. A single channel audio input is fed to dynamic convolution and a single channel output is used as input of KWS network. For this single channel configuration, we compare computational costs (model parameters, time complexity, and space complexity) as summarized in Table 1. For simplicity, conventional Dynamic Convolution(DyConv) and our Lightweight Dynamic Convolution(LDyConv) are only performed on a simple Fully-Connected (FC) layer. For simplicity, normalization and activation processes were not performed.

Model parameters. In DyConv, K dimensional weight vector is driven by the patch size K . Thus, K^2 of parameters are used for DyConv implementation. In LDyConv, the PDF produces K scalar weights from the patch dimension and the IDF generates a weight vector from F by using two FC layers. Thus, LDyConv requires $K(F+1)$ parameters. Since K and F are of the same order, number of parameters required for DyConv and LDyConv are similar.

Time complexity. DyConv computes K^2 for every sample (pixel). With (N) total number of samples, DyConv has $O(K^2N)$ of time complexity. In LDyConv, the PDF computes K for every sample while the IDF is only performed per an audio clip. Thus, time complexity of LDyConv is $O(K(N+F))$ or it is approximately $O(KN)$ since $N \gg F$. Our method would result similar time complexity over the static filter.

Space complexity As the DyConv generates patch-level dynamic weight, it has $O(KN)$ of space complexity for saving dynamic weight vector. On the other hand, our dynamic filter only requires $O(K+N)$ of space complexity.

In summary, our proposed lightweight dynamic convolution model has similar model complexity compared to a static convolution filter model. We confirm that our proposed model consumes 2K parameters and 224K Flops when $K=9$, $F=40$ and $T=98$.

4. EXPERIMENT AND DISCUSSION

4.1. Experimental Setup

Dataset. we used speech command dataset v1 [17] for evaluating KWS performance. Speech command dataset contains 30 classes of 65K audio clips and 10 keywords with two extra classes (unknown or silence). We used 80% of the dataset for training, 10% for validation, and the remaining 10% for test. By following DB guide line of the dataset, we injected background noise and added random time shifting.

Noise setup. For evaluating robustness against noise, we utilized DCASE [18], Urbansound8K [19] and WHAM [20] datasets. These three datasets contain background noise of urban locations. For data argumentation, we randomly selected an audio sample from the noise data and mixed it with the test audio of speech command with 5 different Signal-to-Noise ratios (SNRs) [20dB, 15dB, 10dB, 5dB and 0dB].

Acoustic feature extraction. The acoustic feature we used is Mel Frequency Cepstral Coefficients (MFCC) constructed with 30ms of windows with 10ms overlap from an audio clip sampled at 16kHz. 64 of Mel filters are employed to extract a Mel-spectrogram and 40 MFCC coefficients are extracted. This process gives a [40,98] size of audio features.

Computation setup. All our experiments are done by using TensorFlow deep learning package with RTX-2080 ti GPU. In the training process, we used a batch size of 100, 30k iterations, and ADAM optimizer with 0.001 initial learning rate. Every 10K iteration, the

learning rate is reduced by 0.1 rate.

Implementation detail. In the PDF and the dynamic convolution process, we used 3×3 CNN kernel ($k=9$) dilated by [2,2] with stride=1. In the IDF, first FC and second FC follow 40×40 and $40 \times k$ layer dimensions respectively.

4.2. Baselines

Three different baseline architectures were used for comparisons. We implemented the proposed LDyConv on TENet architecture [8] and compared its performance with the following baseline models. **TCNet.** TCNet [7] (or TC-Resnet) utilized temporal convolution and skip-connection for a fast and low computational cost model. TCNet8 contains 3 convolution blocks and 1 FC layer. Each convolution block has two layers of temporal convolution with a skip-connection. Similarly, TCNet14 contains 6 convolution blocks and 1 FC layer.

TENet. TENet [8] utilizes lightweight TCNet by performing 1D convolution. TENet6 has 6 convolution blocks and 1 FC layer. Each convolution block has two 1D convolution and 1 temporal convolution. TENet12 contains 12 convolution blocks and 1 FC layer. TENet has 32 output channel for each convolution block and TENet-n has 16 output channel for each convolution block.

MHA-RNN. MHA-RNN[21] utilizes CRNN and self attention mechanism for the KWS model training. The output of CRNN feeds to a dot product based Multi Head Attention (MHA) model, and two layers of FC produces probability values for KWS.

Neural Architecture Search. NAS is an network architecture designing method for deep learning applications and Differentiable Architecture Search (DARTS) is a variant of NAS which reduces search cost by weights sharing. We compared various state-of-art NAS methods in keyword spotting. Please see details of model in [9, 10].

4.3. Result discussion

Table 2, 3 and 4 summarize the KWS results on the Speech Command dataset. Our proposed method was applied to TENet based model. For more thorough model evaluation, we repeated the experiment 8 times.

Small footprint KWS. Table 2 shows small footprint KWS performances over state of the art methods. Parameter and Multiplication denote number of training parameters and Flops respectively. In the averaging accuracy column, averaging performance and its standard deviations are shown. Best present the highest accuracy over the 8 repeated experiments. From this experiments, we confirm that our methods (LDy-TENet*) show improved performance over TENet based model. It is noted that LDy-TENet6-n shows similar performance over TENet12 which is 3 times larger model. Also, our LDy-TENet12 achieves best averaging accuracy with low parameters and Flops over the NAS based models.

Unseen noisy environment. Table3 summarizes KWS results on the unseen noisy environment with 3 different noise datasets and 5 different SNRs. In these results, our proposed model shows more robust performance over TENet12 and TCNet14 models. On averaging, 0.5% of performance improvement is observed between LDy-TENet and TENet methods. Especially, 1.3% performance improvement is shown in the Urban 5dB condition.

Reduced training sample. Table 4 presents KWS performance as a function of the amount of the training data used. Training Rate (TR) denotes proportion of the actual data used from the original dataset.

Model	Param.	Mult.	Avg. Acc	Best
TCNet8[7]	145K	2.20M	-	96.2
TCNet14[7]	305K	4.13M	-	96.6
TENet6-n[8]	17K	553K	-	96.0
TENet12-n[8]	31K	895K	-	96.3
TENet6[8]	54K	1.68M	-	96.4
TENet12[8]	100K	2.90M	-	96.6
MHA-RNN[21]	743K	87.2M	-	97.2
NAS2[9]	886K	-	-	97.2
Random[10]	196K	8.8M	96.58(0.15)	96.8
DARTS[10]	93K	4.9M	96.63(0.22)	96.9
F-DARTS[10]	188K	10.6M	96.70(0.11)	96.9
N-DARTS[10]	109K	6.3M	96.79(0.32)	97.2
LDy-TENet6-n	19K	777K	96.48(0.25)	97.0
LDy-TENet12-n	33K	1.12M	96.69(0.13)	96.9
LDy-TENet6	56K	1.91M	96.77(0.09)	96.9
LDy-TENet12	102K	3.13M	96.95 (0.08)	97.1

Table 2: Comparison with lightweight models on Speech Command v1: Param. and Multi. denote Model parameters and Flops respectively. In DARTS and LDy-TENet model, 8 times averaging accuracy with STD. and best performance are presented.

Lower TR, therefore, means reduced speaker or domain diversity of the training. The results show that our dynamic filter works robustly in small datasets, and its performance is higher over all the training rates.

From these experiments, we confirm that our proposed method enhances KWS performance in both noisy and small data training scenarios over state-of-the-art models.

5. CONCLUSION

The main focus of this study was to develop a lightweight dynamic filter model for an acoustic feature extractor in Keyword spotting. While employing dynamic filters makes KWS more adaptive to various input conditions, it requires higher computational cost. To address this issue, we proposed Lightweight Dynamic Convolution (LDy-Conv) model which decomposes a dynamic filter into two parts for alleviating the issue of computational cost. Pixel Dynamic Filter (PDF) produces scalar weights for each pixel and Instance-level Dynamic Filter (IDF) generates a single unit weight vector for the dynamic filter computation. The process has a small footprint and fast compared to conventional dynamic filters while retaining adaptability of a dynamic filter. The experiments show that our proposed lightweight model is robust on unseen noise even with small training datasets.

6. ACKNOWLEDGEMENTS

This work was supported by Korea Environment Industry & Technology Institute(KEITI) through Exotic Invasive Species Management Program, funded by Korea Ministry of Environment(MOE) (2021002280004)

Noise	SNR (dB)	Model		
		LDy-TENet	TENet	TCNet
DCASE [18]	20	96.58	96.28	95.85
	15	96.44	96.23	95.59
	10	95.10	94.94	94.25
	5	93.00	92.87	91.79
	0	88.41	88.14	86.01
Urban [19]	20	95.94	95.72	95.16
	15	95.09	94.69	93.61
	10	92.82	92.17	90.77
	5	89.19	87.97	86.38
	0	78.55	77.54	74.20
WHAM [20]	20	96.09	95.75	95.43
	15	95.47	95.12	94.44
	10	92.91	92.67	91.46
	5	88.19	87.88	85.72
	0	75.92	75.19	73.15
Total-AVG.		91.31	90.87	89.59

Table 3: Comparison with Unseen noise environment: experiment is performed on LDy-TENet12, TENet12 and TCNet14 model. SNR denotes signal to noise ratio.

Model	Training Rate				
	0.75	0.5	0.25	0.10	0.05
LDy-TENet12	96.52	96.36	94.88	92.8	90.28
TENet12	96.34	95.8	94.59	92.08	89.54

Table 4: Comparison with reduced training data: Training Rate (TR) denotes rate of the training sample from original dataset.

7. REFERENCES

- [1] Yassine Benayed, Dominique Fohr, Jean Paul Haton, and Gérard Chollet, “Confidence measures for keyword spotting using support vector machines,” in *2003 IEEE International Conference on Acoustics, Speech, and Signal Processing, 2003. Proceedings.(ICASSP’03)*. IEEE, 2003, vol. 1, pp. I–I.
- [2] Hamed Ketabdar, Jithendra Vepa, Samy Bengio, and Hervé Bourlard, “Posterior based keyword spotting with a priori thresholds,” in *Ninth International Conference on Spoken Language Processing*, 2006.
- [3] Guoguo Chen, Carolina Parada, and Georg Heigold, “Small-footprint keyword spotting using deep neural networks,” in *2014 IEEE International Conference on Acoustics, Speech and Signal Processing (ICASSP)*. IEEE, 2014, pp. 4087–4091.
- [4] Tara N Sainath and Carolina Parada, “Convolutional neural networks for small-footprint keyword spotting,” in *Sixteenth Annual Conference of the International Speech Communication Association*, 2015.
- [5] Sercan O Arik, Markus Kliegl, Rewon Child, Joel Hestness, Andrew Gibiansky, Chris Fougner, Ryan Prenger, and Adam Coates, “Convolutional recurrent neural networks for small-footprint keyword spotting,” *arXiv preprint arXiv:1703.05390*, 2017.
- [6] Yundong Zhang, Naveen Suda, Liangzhen Lai, and Vikas

- Chandra, "Hello edge: Keyword spotting on microcontrollers," *arXiv preprint arXiv:1711.07128*, 2017.
- [7] Seungwoo Choi, Seokjun Seo, Beomjun Shin, Hyeongmin Byun, Martin Kersner, Beomsu Kim, Dongyoung Kim, and Sungjoo Ha, "Temporal convolution for real-time keyword spotting on mobile devices," *arXiv preprint arXiv:1904.03814*, 2019.
- [8] Ximin Li, Xiaodong Wei, and Xiaowei Qin, "Small-footprint keyword spotting with multi-scale temporal convolution," *arXiv preprint arXiv:2010.09960*, 2020.
- [9] Tong Mo, Yakun Yu, Mohammad Salameh, Di Niu, and Shangling Jui, "Neural architecture search for keyword spotting," *arXiv preprint arXiv:2009.00165*, 2020.
- [10] Bo Zhang, Wenfeng Li, Qingyuan Li, Weiji Zhuang, Xiangxiang Chu, and Yujun Wang, "Autokws: Keyword spotting with differentiable architecture search," in *ICASSP 2021-2021 IEEE International Conference on Acoustics, Speech and Signal Processing (ICASSP)*. IEEE, 2021, pp. 2830–2834.
- [11] Xu Jia, Bert De Brabandere, Tinne Tuytelaars, and Luc V Gool, "Dynamic filter networks," in *Advances in neural information processing systems*, 2016, pp. 667–675.
- [12] Donghyeon Kim, Jaihyun Park, David K Han, and Hanseok Ko, "Dual stage learning based dynamic time-frequency mask generation for audio event classification," *Proc. Interspeech 2020*, pp. 836–840, 2020.
- [13] Felix Wu, Angela Fan, Alexei Baevski, Yann N Dauphin, and Michael Auli, "Pay less attention with lightweight and dynamic convolutions," *arXiv preprint arXiv:1901.10430*, 2019.
- [14] Yuya Fujita, Aswin Shanmugam Subramanian, Motoi Omachi, and Shinji Watanabe, "Attention-based asr with lightweight and dynamic convolutions," in *ICASSP 2020-2020 IEEE International Conference on Acoustics, Speech and Signal Processing (ICASSP)*. IEEE, 2020, pp. 7034–7038.
- [15] Ashish Vaswani, Noam Shazeer, Niki Parmar, Jakob Uszkoreit, Llion Jones, Aidan N Gomez, Lukasz Kaiser, and Illia Polosukhin, "Attention is all you need," in *Advances in neural information processing systems*, 2017, pp. 5998–6008.
- [16] Jingkai Zhou, Varun Jampani, Zhixiong Pi, Qiong Liu, and Ming-Hsuan Yang, "Decoupled dynamic filter networks," in *Proceedings of the IEEE/CVF Conference on Computer Vision and Pattern Recognition*, 2021, pp. 6647–6656.
- [17] Pete Warden, "Speech commands: A dataset for limited-vocabulary speech recognition," *arXiv preprint arXiv:1804.03209*, 2018.
- [18] Annamaria Mesaros, Toni Heittola, and Tuomas Virtanen, "Acoustic scene classification in dcase 2019 challenge: Closed and open set classification and data mismatch setups," 2019.
- [19] Justin Salamon, Christopher Jacoby, and Juan Pablo Bello, "A dataset and taxonomy for urban sound research," in *Proceedings of the 22nd ACM international conference on Multimedia*, 2014, pp. 1041–1044.
- [20] Gordon Wichern, Joe Antognini, Michael Flynn, Licheng Richard Zhu, Emmett McQuinn, Dwight Crow, Ethan Manilow, and Jonathan Le Roux, "Wham!: Extending speech separation to noisy environments," in *Proc. Interspeech*, Sept. 2019.
- [21] Oleg Rybakov, Natasha Kononenko, Niranjan Subrahmanya, Mirko Visontai, and Stella Laurenzo, "Streaming keyword spotting on mobile devices," *arXiv preprint arXiv:2005.06720*, 2020.