

MiB: Asynchronous BFT with More Replicas

Chao Liu, Sisi Duan, and Haibin Zhang

Abstract—State-of-the-art asynchronous Byzantine fault-tolerant (BFT) protocols, such as HoneyBadgerBFT, BEAT, and Dumbo, have shown a performance comparable to partially synchronous BFT protocols. This paper studies two practical directions in asynchronous BFT. First, while all these asynchronous BFT protocols assume optimal resilience with $3f + 1$ replicas (where f is an upper bound on the number of Byzantine replicas), it is interesting to ask whether more efficient protocols are possible if relaxing the resilience level. Second, these recent BFT protocols evaluate their performance under failure-free scenarios. It is unclear if these protocols indeed perform well during failures and attacks.

This work first studies asynchronous BFT with suboptimal resilience using $5f + 1$ and $7f + 1$ replicas. We present MiB, a novel and efficient asynchronous BFT framework using new distributed system constructions as building blocks. MiB consists of two main BFT instances and five other variants. As another contribution, we systematically design experiments for asynchronous BFT protocols with failures and evaluate their performance in various failure scenarios. We report interesting findings, showing asynchronous BFT indeed performs consistently well during various failure scenarios. In particular, via a five-continent deployment on Amazon EC2 using 140 replicas, we show the MiB instances have lower latency and much higher throughput than their asynchronous BFT counterparts.

Index Terms—Byzantine fault tolerance, asynchronous BFT, suboptimal resilience, reliable broadcast, binary agreement.



1 INTRODUCTION

State machine replication (SMR) is a popular software technique achieving high availability and strong consistency guarantees in today’s distributed applications (e.g., Apache ZooKeeper [30], Google’s Spanner [13]). Byzantine fault-tolerant SMR (BFT) is known as *the* model for permissioned blockchains, where the replicas need to authenticate themselves but do not necessarily trust each other. BFT is also used in permissionless blockchains (where nodes may join and leave the systems dynamically) to enhance the performance and achieve finality (e.g., [5], [31], [32], [37], [43], [53]).

Different from partially synchronous BFT protocols, asynchronous BFT protocols do not rely on any timing assumptions and are therefore more robust against performance, timing, and denial-of-service attacks. For this reason, many asynchronous BFT (atomic broadcast) protocols have been proposed [6], [8], [9], [14], [16], [22], [34], [41], [46]. In particular, several asynchronous BFT protocols proposed recently, HoneyBadgerBFT [40], BEAT [25], EPIC [36], and Dumbo [28], have comparable performance as partially synchronous BFT protocols (e.g., PBFT [19]) and can scale to around 100 replicas. These efficient protocols follow the asynchronous common subset (ACS) framework [8]. The ACS framework consists of a reliable broadcast (RBC) component and an asynchronous binary agreement (ABA) component. HoneyBadgerBFT, BEAT, EPIC, and Dumbo all use RBC and ABA and are different only in concrete instantiations.

All these efficient asynchronous BFT protocols using RBC and ABA assume *optimal resilience*. Namely, if the system has n replicas, it tolerates $f < n/3$ Byzantine failures. Even in the best-

case scenario, each asynchronous BFT epoch has at least six steps and the expected number of steps is much higher.¹ The situation is in sharp contrast to partially synchronous BFT protocols which usually have fewer steps (PBFT [19], for instance, terminates in three steps in the worst-case scenario).

This paper proposes MiB, faster asynchronous BFT protocols with *suboptimal resilience*, including MiB5 (the case of $n \geq 5f + 1$) and MiB7 (the case of $n \geq 7f + 1$). Our technique is *generic* and can be applied to *all* of the four state-of-the-art asynchronous BFT protocols (HoneyBadgerBFT, BEAT, EPIC, and Dumbo). To illustrate our approach, we use BEAT as the underlying protocol, as BEAT is simpler than EPIC and Dumbo, and has the most efficient open-source implementation available [1]. (In fact, MiB can be based on any ACS instantiation or any asynchronous BFT using RBC and ABA.) For both MiB5 and MiB7, each epoch may terminate in as few as just *three* steps in the best-case scenario.

MiB techniques in a nutshell. At the core of MiB are new RBC constructions and new ABA combinations with suboptimal resilience, enabling faster termination and higher throughput.

For MiB5, we devise MBC, an erasure-coded version of Imbs and Raynal’s RBC (IR RBC) [23] which terminates in two steps by requiring $n \geq 5f + 1$. MBC is bandwidth-efficient and step-optimal. In contrast, previous asynchronous BFT protocols use Bracha’s broadcast or the AVID broadcast [17], either of which completes in three steps. MBC integrates the technique of AVID (using Merkle tree) and we formally prove the correctness of MBC. For MiB5, we instantiate the ABA construction in the ACS framework using a new combination of Bosco’s weakly one-step ABA (WIS) [47] that requires $n \geq 5f + 1$ and the Cobalt ABA [38]. In ideal situations, the new ABA construction terminates in just one step; otherwise, it falls back to the state-of-the-art Cobalt ABA.

1. In the best-case scenario, ACS includes a RBC phase with n (parallel) RBC instances and an ABA phase with n (parallel) ABA instances. RBC takes three steps whether using Bracha’s broadcast [11] or the AVID broadcast [17]. The state-of-the-art ABA construction, the Cobalt ABA [38], has three or four steps in each round and the protocol may terminate in one or several rounds.

- C. Liu is with the Department of Computer Science and Electrical Engineering, University of Maryland, Baltimore County, Baltimore, MD, 21250. E-mail: chaoliu717@umbc.edu
- S. Duan is with Tsinghua University. Corresponding author. E-mail: duansisi@mail.tsinghua.edu.cn
- H. Zhang is with Shandong Institute of Blockchain. Corresponding author. E-mail: bchainzhang@aliyun.com

For MiB7, considering the step-optimal property of MBC, one may intuitively use MBC, even if there are more than $7f + 1$ replicas. We show that we can achieve better performance by asking a fraction of replicas to be passive learners rather than active RBC participants. Our new RBC construction, MBC with learners, or simply MBC-L, involves (much) fewer messages. We formally prove the correctness of MBC-L. For ABA, we combine Bosco’s strongly one-step ABA (S1S) that requires $n \geq 7f + 1$ and the Cobalt ABA.

A (powerful) programming and evaluation platform. We build an asynchronous BFT programming and evaluation platform that fulfills two goals. First, the platform allows us to answer important research questions. For instance, how could one be certain that our RBC and ABA choices would perform as expected? More importantly, do we have other combinations that would lead to BFT with better performance? The platform allows mixing and matching different RBC and ABA primitives. Our framework has a flexible but unified API and is highly expressive: in total, we design and implement seven fully-fledged asynchronous BFT instances using different RBC and ABA combinations.

Second, the platform allows us to perform experiments under failures and attacks. To the best of our knowledge, while state-of-the-art asynchronous BFT protocols, including HoneyBadgerBFT, BEAT, EPIC, and Dumbo, claim that they are more robust than partially synchronous BFT protocols in failure scenarios, no experiments are provided to validate the claims. The only framework we know does so is RITAS [41] that perform evaluation for one specific asynchronous BFT protocol using less than 10 replicas in LANs. Our platform can, however, perform experiments under various failure scenarios (crash, Byzantine, attacks) and allow us to compare different BFT protocols in a unified framework in a systematic manner.

Our contributions. We summarize our contributions in the following:

- We design new distributed system primitives with suboptimal resilience, including new RBC constructions and ABA combinations. In particular, we provide an erasure-coded version of IR RBC using Merkle tree and provide a learner-version of RBC (where some replicas are passive learners). We formally prove the correctness of the new RBC constructions.
- We build a highly flexible MiB framework allowing mixing and matching different RBC and ABA primitives. The framework consists of asynchronous BFT protocols described (MiB5 and MiB7) and five other variants. We provide meaningful tradeoffs among various situations, echoing the well-known claim that there is no “one-size-fits-all” BFT.
- We design experiments for asynchronous BFT protocols in failure and attack scenarios. This is the first systematic evaluation for these recent asynchronous BFT protocols using the ACS framework.
- We have evaluated all seven MiB protocols and their competitors on Amazon EC2 with hundreds of experiments using up to 140 instances. We show that almost all MiB instances, in particular, MiB5 and MiB7, are much more efficient, in terms of both latency and throughput than their asynchronous BFT counterparts. Moreover, we show existing asynchronous BFT protocols, not just MiB protocols, are indeed robust against failures and attacks. We report many interesting results for different scenarios.

2 RELATED WORK

BFT with suboptimal resilience. A number of BFT protocols assume $n > 3f + 1$. For instance, Q/U requires $5f + 1$ replicas to tolerate f failures and achieves fault-scalability that tolerates increasing numbers of failures without largely decreasing performance [4]. BChain5 uses $5f + 1$ replicas to simplify the failure detection mechanism and remove the need for replica reconfiguration [24]. Zyzzyva5 uses $5f + 1$ replicas and trades the number of replicas in the system against performance in the presence of faults [33]. FaB Paxos [39] is efficient partially synchronous BFT protocol using $5f + 1$ replicas and having 3 communication steps per request.

Efficient asynchronous atomic broadcast and BFT. Most of the efficient asynchronous atomic broadcast (BFT) protocols follow the Ben-Or’s ACS framework [8], including SINTRA [16], HoneyBadgerBFT [40], BEAT [25], EPIC [36], and Dumbo [28]. They are different only in concrete instantiations. SINTRA, HoneyBadgerBFT, BEAT, and Dumbo achieve static security, where the adversary needs to choose the set of corrupted replicas before the execution of the protocol. In contrast, EPIC attains stronger adaptive security, where the adversary can choose to corrupt replicas at any moment during the execution of the protocol. Dumbo devises a new way of instantiating the ACS framework by using fewer ABA instances and achieves better performance. There are, however, efficient asynchronous BFT protocols that do not follow the ACS framework, including, for instance, RITAS [41]. DBFT [51] relies on an asynchronous framework but works in partially synchronous environments and is very efficient.

Asynchronous binary agreement (ABA) with optimal resilience. Beginning with Ben-Or [8] and Rabin [45], a significant number of ABA protocols have been proposed [10], [12], [15], [18], [27], [38], [42], [45], [48], [49], [50], [54]. Cachin, Kursawe, and Shoup (CKS) [15] proposed an ABA with optimal resilience and $O(n^2)$ message complexity. Mostefaoui, Moumen, and Raynal (MMR) [42] proposed the first signature-free ABA with the same message complexity as the CKS ABA [15]. The MMR ABA protocol was used by HoneyBadgerBFT, BEAT, and Dumbo. It was later reported that the MMR ABA has a liveness issue when being instantiated using any coin-flipping protocols known [2]. The Cobalt ABA protocol resolves the issue at the price of one more step for each round [38]. The Cobalt ABA is used in EPIC and an open-source implementation of BEAT [1]. Dumbo recently updated its ePrint version [29] by using the Cobalt ABA (code still unavailable).

ABA with suboptimal resilience. Assuming $n \geq 5f + 1$, Berman and Garay [10] presented a common coin based ABA protocol that has only two steps in each round. The ABA protocol by Friedman, Mostefaoui, and Raynal (FMR) [44] extended BG and reduced the number of steps within a round to one. Song and van Renesse [47] proposed Bosco that terminates in one step in ideal situations, a protocol that we use in this paper.

3 SYSTEM AND THREAT MODEL

We consider a Byzantine fault-tolerant state machine replication (BFT) protocol with n replicas, at most f of which may exhibit arbitrary behavior (Byzantine failures). Most of BFT protocols assume optimal resilience with $n \geq 3f + 1$. In this work, we consider suboptimal resilience with $n \geq 5f + 1$ and $n \geq 7f + 1$.

In BFT, replicas deliver transactions (requests) submitted by clients and send replies to clients. A BFT protocol should satisfy the following properties:

- **Agreement:** If any correct replica delivers a transaction tx , then every correct replica delivers tx .
- **Total order:** If a correct replica has delivered transactions $\langle tx_0, tx_1, \dots, tx_j \rangle$ and another has delivered $\langle tx'_0, tx'_1, \dots, tx'_j \rangle$, then $tx_i = tx'_i$ for $0 \leq i \leq \min(j, j')$.
- **Liveness:** If a transaction tx is submitted to $n - f$ replicas, then all correct replicas will eventually deliver tx .

According to the timing assumptions, BFT protocols can be divided into three categories: *asynchronous*, *synchronous*, or *partially synchronous* [26]. Asynchronous BFT systems make no timing assumptions on message processing or transmission delays. Synchronous BFT systems have a known bound on message processing delays and transmission delays. Partially synchronous BFT systems lie in-between: messages will be delivered within a time bound, but the bound may be unknown to anyone. Asynchronous BFT protocols are inherently more robust than other BFT protocols. This paper considers purely asynchronous systems making no timing assumptions on message processing or transmission delays.

4 BUILDING BLOCKS

This section reviews the building blocks for MiB.

Erasure coding. An (m, n) maximum distance separable (MDS) erasure coding scheme can encode m data blocks (fragments) into n ($n \geq m$) coded blocks, and all blocks can be recovered from any m -size subset of coded blocks via a decode algorithm. This paper by default uses MDS erasure coding.

Byzantine reliable broadcast (RBC). In RBC, a sender broadcasts a message to all other replicas in a group. An asynchronous RBC protocol satisfies the following properties:

- **Validity:** If a correct replica p broadcasts a message m , then p eventually delivers m .
- **Agreement:** If some correct replica delivers a message m , then every correct replica eventually delivers m .
- **Integrity:** For any message m , every correct replica delivers m at most once. Moreover, if the sender is correct, then m was previously broadcast by the sender.

Asynchronous binary agreement (ABA). In ABA, each replica has a binary value $v \in \{0, 1\}$ (a vote) as the input, and correct replicas eventually deliver the same binary value as the output. ABA guarantees the following properties.

- **Validity:** If a correct replica delivers a value v , the v was proposed by at least one correct replica.
- **Agreement:** If a correct replica delivers v and another correct replica delivers v' , then $v = v'$.
- **Termination:** All correct replicas eventually deliver a value with probability 1.
- **Unanimity:** If all correct replicas input the same initial value v , then a correct replica delivers v .

ABA protocols proceed in rounds, each of which includes several steps. We define one-step ABA as one ensuring one-step communication under the unanimity property, i.e., replicas terminate in one step if all correct replicas propose the same binary value [47].

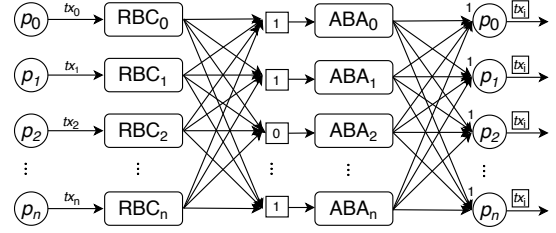

Fig. 1. The ACS consensus workflow.

5 TECHNICAL OVERVIEW

State-of-the-art asynchronous BFT protocols, such as HoneyBadgerBFT, BEAT, EPIC, and Dumbo, follow the asynchronous common subset (ACS) framework which includes a RBC phase and an ABA phase.

We consider asynchronous BFT protocols (collectively called MiB) using the ACS framework with *suboptimal resilience*. At the core of the MiB protocols are new RBC constructions and new ABA combinations with suboptimal resilience. These new RBC constructions and ABA combinations are rather generic and can be applied to any ACS instantiations. For illustrative purposes, we follow the BEAT workflow (as depicted in Figure 1): BEAT is slightly simpler than EPIC and Dumbo and has the most efficient open-source implementation available [1].

ABA with suboptimal resilience. HoneyBadgerBFT, BEAT, and Dumbo used the MMR ABA with optimal resilience [42]. The MMR ABA includes two to three steps in each round. The protocol, however, was found to have a liveness issue [2]. The Cobalt ABA protocol resolves the problem at the price of one more step for each round [38]. EPIC uses the Cobalt ABA, and some asynchronous BFT libraries (e.g., BEAT [1]) have updated their implementation using the Cobalt ABA.

For MiB, we use Bosco’s one-step ABA protocols [47]: weakly one-step ABA (WIS) using $n \geq 5f + 1$ replicas and strongly one-step ABA (SIS) using $n \geq 7f + 1$ replicas. Both WIS and SIS terminate in as minimum as one single step (one round). WIS achieves this property when all replicas propose the same binary input (contention-free) and there are no faulty replicas (failure-free). SIS achieves this property under the contention-free condition but does not assume a failure-free condition. Bosco’s ABA needs to run a backup ABA protocol when the conditions are not satisfied. We thus use a combination of WIS and the Cobalt ABA for MiB5 (the case of $n \geq 5f + 1$) and a combination of SIS and the Cobalt ABA for MiB7 (the case of $n \geq 7f + 1$).

RBC with suboptimal resilience. We devise MBC, an erasure-coded version of IR RBC [23] which terminates in two steps by requiring $n \geq 5f + 1$. MBC is bandwidth-efficient and step-optimal. The low bandwidth property has shown to be extremely useful for the performance of HoneyBadgerBFT and more so for BEAT; it turns out that the step-optimal property also improves the system performance.

RBC with learners. When $n \geq 5f + 1$, we have already obtained a step-optimal RBC (MBC) which terminates in two steps. There does not exist a one-step RBC, no matter how many replicas one uses. While one may consider simply using MBC directly for the case of $n \geq 7f + 1$, we can actually do better.

We use the concept of *learners* (see, e.g., Paxos [35]) and propose *RBC with learners*. If there is a RBC that requires n_1 replicas and an ABA that requires n_2 replicas, where $n_2 > n_1$, then n_1 replicas are active replicas and $n_2 - n_1$ replicas are

learners. The learners do not actively participate in RBC but only learn the results. When an active replica delivers a message, it forwards the message to all learners. A learner delivers a message when it receives $n_1 - f$ matching messages and then enters the ABA phase. Compared to regular RBC, RBC with learners reduces the number of messages transmitted. RBC with learners is a general primitive. The specific MBC extension is called MBC-L, and the AVID extension is called AVID-L.

The MiB framework. To examine if the above new primitives or combinations could improve performance as expected, we build a highly modular and expressive framework. In such a framework, we mix and match various RBC and ABA primitives to design and implement seven asynchronous BFT protocols with suboptimal resilience. The framework is modular: various components are programmed to fit in a unified but flexible standard API (for varying f and n 's). It is the framework that allows us to have a clear picture on the performance bottlenecks for all MiB instances, validate our theoretical design, and help find meaningful trade-offs.

6 MiB

6.1 MiB framework

This section describes the MiB protocols. In MiB, we propose new RBC primitives and new ABA combinations as building blocks. The building blocks can be applied to all asynchronous BFT systems using the ACS framework or any asynchronous BFT using RBC and ABA. To illustrate our approach, MiB is built on top of BEAT which has the most efficient open-source implementation available [1].

MiB protocols are different only in concrete RBC and ABA instantiations. So when describing MiB in general, we use RBC and ABA in a black-box manner. Figure 2 depicts the MiB framework which is the same as BEAT. MiB proceeds in epochs numbered by r (initially, 0). In an epoch, replicas choose a subset of transactions as a *proposal* from their transaction pool and agree on a set containing the union of the proposals of at least $n - f$ replicas. We define B as the batch size of the transactions for an epoch; the batch size for a replica $b = \lceil B/n \rceil$. Replicas first run a RBC phase to broadcast their proposals. Then they run an ABA phase, where n parallel ABA instances are invoked. The i -th ABA instance agrees on whether the proposal of replica p_i has been delivered in the RBC phase. If a correct replica p_j terminates the i -th ABA instance with 1, the proposal from p_i is delivered. Otherwise, the proposal is not included. We ensure that at least $n - f$ ABA instances terminate with 1 and the union of the transactions from at least $n - f$ replicas are delivered. To do this, each replica abstains from proposing 0 until $n - f$ ABA instances have been delivered by the replica. As in BEAT, MiB uses threshold encryption to avoid transaction censorship and achieve liveness (the pseudocode of threshold encryption is not shown in Figure 2).

6.2 MiB5

For MiB5, we instantiate the ABA component in the ACS framework using a new combination of Bosco's weakly one-step ABA (WIS) [47] that requires $n \geq 5f + 1$ and the Cobalt ABA [38]. We also devise MBC, an erasure-coded version of IR RBC [23] which completes in two steps (optimal) and requires $n \geq 5f + 1$.

Algorithm: MiB Protocol (Replica p_i)

Initialization
 let B be the batch size parameter
 let $\text{buf} \leftarrow \emptyset$ be a transaction buffer
 let $\{\text{RBC}_j\}_{j \in n}$ and $\{\text{ABA}_j\}_{j \in n}$ be the j -th instance for RBC _{j} and ABA _{j}
 let $\text{output} \leftarrow \emptyset$ be the output buffer
 let $r \leftarrow 0$ be the epoch number

epoch r
 select $b = \lceil B/n \rceil$ random transactions from the first B elements in buf as a proposal value
upon input value value
 input value to RBC _{i}
upon delivery of value_j from RBC _{j}
 if ABA _{j} has not yet been provided input, input 1 to ABA _{j}
upon delivery of 1 from ABA _{j} and value_j from RBC _{j}
 $\text{output} \leftarrow \text{output} \cup \text{value}_j$
upon delivery of 1 from at least $n - f$ ABA instances
 for each ABA _{j} instance that has not been provided input
 input 0 to ABA _{j}
upon termination of all the n ABA instances
 deliver output
 $r \leftarrow r + 1$

Fig. 2. The MiB algorithm for p_i .

Algorithm: WIS/SIS

Initialization
 $r \leftarrow 0$ {round}
 v_p {input value}

round r
 broadcast $\text{bval}(v_p)$ {broadcast input}
upon receiving $\text{bval}(v)$ from $n - f$ replicas
if more than $\lceil (n + 3f)/2 \rceil$ $\text{bval}(v)$ messages contain the same value v
 deliver v {terminate the protocol}
if more than $\lceil (n - f)/2 \rceil$ $\text{bval}(v)$ messages contain the same value v , and there is only one such value v
 $v_p \leftarrow v$
 backup-ABA(v_p)

Fig. 3. The algorithm for WIS and SIS.

Weakly one-step (WIS). The state-of-the-art ABA for the $n \geq 3f + 1$ case, the Cobalt ABA, requires at least three steps in each round. For the case of $n \geq 5f + 1$, we use the Bosco's weakly one-step ABA protocol (WIS) [47].

WIS guarantees that if there are *no faulty* replicas and all replicas propose the *same* initial value v , then all the correct replicas deliver v and terminate the protocol in one step (one round). Figure 3 describes the pseudocode of WIS protocol. Each replica has a binary input v_p to the ABA. In the first step, each replica p_i broadcasts a message $\text{bval}(v_p)$. A replica p_i waits for $\text{bval}(v)$ from $n - f$ replicas (including itself). If more than $\lceil \frac{n+3f}{2} \rceil$ $\text{bval}(v)$ messages include the same value v , a replica delivers v and terminates the protocol. If more than $\lceil \frac{n-f}{2} \rceil$ $\text{bval}(v)$ messages include the same v , a replica sets its local value to $v_p = v$. If the replica does not deliver any value in one step, it invokes a backup ABA protocol. In MiB5, we use the Cobalt ABA protocol [38] as the backup ABA protocol.

MBC. MBC is an erasure-coded version of IR RBC [23] which completes in two steps. MBC is bandwidth-efficient and step-optimal. We show the MBC workflow in Figure 4 and the MBC pseudocode in Figure 5.

As depicted in Figure 5, to broadcast a message m , a replica

	resilience level	steps	number of messages
AVID	$n \geq 3f + 1$	3	$2n^2 + n$
MBC	$n \geq 5f + 1$	2	$n^2 + n$

TABLE 1
Comparison of the RBC algorithms.

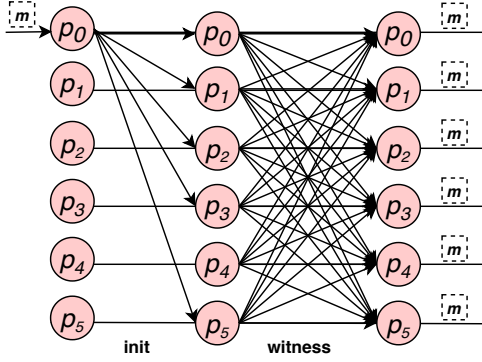

Fig. 4. The MBC workflow, where p_0 broadcasts a message m and there are no faulty replicas.

Algorithm: MBC (Replica p_i)	
upon input (m)	$\{ \text{if } p_{\text{sender}} = p_i \}$ let l_j be the j -th block of $(n - 2f, n)$ erasure coding scheme applied to m h is the root of the Merkle tree for the $\{l_j\}_{j \in [0..n-1]}$ blocks send $\text{init}(h, b_j, l_j)$ to each p_j , where b_j is the j -th Merkle tree branch
upon receiving $\text{init}(h, b_i, l_i)$ from p_{sender}	broadcast $\text{witness}(h, b_i, l_i)$
upon receiving $n - 2f$ valid $\text{witness}(h, b_j, l_j)$	interpolate $\{l'_j\}$ from the $n - 2f$ blocks recompute Merkle root h' and if $h' \neq h$ then abort if $\text{witness}(h, b_i, l_i)$ is not sent broadcast $\text{witness}(h, b_i, l_i)$
upon receiving $n - f$ valid $\text{witness}(h, b_j, l_j)$	$m \leftarrow \text{decode}(\{l_j\})$ $\{ \text{from any } n - 2f \text{ blocks} \}$ deliver (m)

Fig. 5. The MBC protocol. A message (h, b_j, l_j) is valid, if b_j is a valid Merkle tree branch for the Merkle tree root h and the data block l_j .

p_i applies the $(n - 2f, n)$ erasure coding scheme to generate n blocks, where the j -th block is denoted as l_j . The replica p_i then generates a Merkle tree for the n blocks. Finally, for j between 0 to $n - 1$, replica p_i sends an $\text{init}(h, l_j, b_j)$ message to the j -th replica p_j , where h is the root of the Merkle tree and b_j is the j -th Merkle tree branch. We say a message (h, b_j, l_j) is valid, if b_j is a valid Merkle tree branch for the Merkle tree root h and the data block l_j .

If a replica p_i receives an $\text{init}(h, l_i, b_i)$ message, p_i broadcasts $\text{witness}(h, l_i, b_i)$.

If a replica p_i receives $n - 2f$ valid $\text{witness}(h, l_j, b_j)$ messages, p_i interpolates all n blocks from $n - 2f$ blocks, recomputes the Merkle tree root h' . If $h' \neq h$ and it has not broadcast any $\text{witness}()$ message, it broadcasts $\text{witness}(h, l_i, b_i)$. Otherwise, it simply aborts.

If p_i receives $n - f$ valid $\text{witness}()$ messages, p_i recovers the original input m and delivers m .

As shown in Table 1, assuming the same n , MBC has fewer

steps and fewer messages than AVID (used in HoneyBadgerBFT, BEAT, and Dumbo).

Theorem 1. The MBC protocol in Figure 5 is a reliable broadcast protocol.

Proof: We prove the theorem from scratch (instead of using the proof of IR MBC in a black-box manner).

We first prove validity. If a correct sender broadcasts a message m , it will erasure code the message m into n blocks $\{l_j\}_{j \in [0..n-1]}$ (where $n - 2f$ blocks are sufficient to recover m), and generates a Merkle tree proof (h, b_j) for each block l_j . Then the sender sends j -th block l_j and the corresponding proof (h, b_j) to the corresponding replica p_j . Upon receiving an init message, each replica will verify whether the message is valid and then broadcasts the witness messages to all replicas. Eventually, all correct replicas will receive $n - f$ witness valid messages. Since the sender is correct, the recomputed Merkle root must equal the agreed one. Any correct replica p_j can recover m using $n - 2f$ erasure coding scheme with matching root and then deliver m .

We now prove agreement. If some correct replica p_i delivers a message m with some h , then the replica must have received $n - f$ valid witness messages with the matching root h . Among these $n - f$ replicas, at least $n - 2f$ replicas are correct. These correct replicas must have received the $\text{init}(h, \cdot, \cdot)$ messages and must have sent $\text{witness}(h, \cdot, \cdot)$ messages to all replicas. Therefore, all correct replicas will receive valid $n - 2f$ $\text{witness}(h, \cdot, \cdot)$ messages. We claim that if p_i delivers a message with h , then except with negligible probability, any other correct replica will not abort (as the recomputed Merkle root $h' = h$). Otherwise, one can find an adversary attacking the Merkle tree (more concretely, attacking the collision resistance property of the underlying hash function of the Merkle tree). Therefore, all correct replicas will broadcast $\text{witness}(h, \cdot, \cdot)$ and eventually all correct replicas will receive $n - 2f$ valid $\text{witness}(h, \cdot, \cdot)$ messages. Again, according to the property of the Merkle tree, all correct replicas can recover and deliver the same m .

Finally, integrity holds by inspection of the protocol. This completes the proof of the theorem. \square

6.3 MiB7

In MiB7, we combine Bosco's strongly one-step ABA (S1S) for $n \geq 7f + 1$ and the Cobalt ABA. We design a new RBC construction, MBC with learners, or simply MBC-L, to further reduce the number of messages transmitted.

Strongly one-step (S1S). The strongly one-step ABA (S1S) is another one-step algorithm for $n \geq 7f + 1$ in Bosco [48]. S1S runs the same algorithm as WIS but achieves different properties. If all correct replicas propose the same initial value v , all correct replicas deliver v in one communication step. Namely, S1S guarantees one-step termination under contention-free situations; it does not require the failure-free conditions needed for the one-step termination in WIS. As in MiB5, MiB7 uses the Cobalt ABA as the backup ABA protocol.

MBC-L. When $n \geq 5f + 1$, MBC is already a step-optimal RBC. While intuitively for the case of $n \geq 7f + 1$, one could use MBC directly, we actually use *MBC with learners* (MBC-L). In such a primitive, some replicas are just learners instead of active replicas participating in the main broadcast process. But of course, MBC-L remains a standard RBC satisfying all RBC properties.

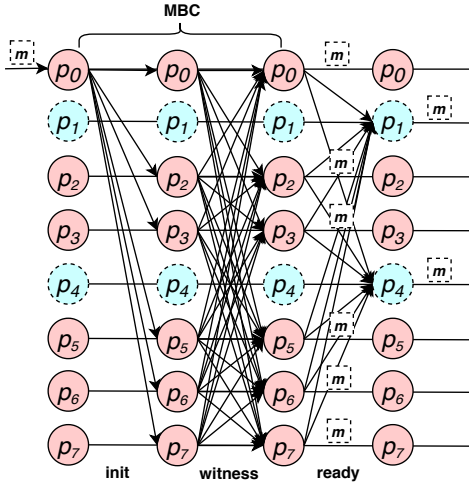

Fig. 6. The MBC-L workflow. Replica p_0 is the broadcaster, replicas in solid circles are active replicas, and replicas in dashed circles are learners. Active replicas run the MBC protocol to deliver the message m and forward it to the learners once the message is delivered.

Algorithm: MBC-L in MiB7 (Replica p_i)

upon input (m) {if $p_{sender} = p_i$ }
 $active_rep \leftarrow n_1 = 5f + 1$ active replicas
let l_j be the j -th block of $(n_1 - 2f, n_1)$ erasure coding scheme applied to m
 h is the root of the Merkle tree for the $\{l_j\}_{j \in [0..n_1]}$ blocks
send $init(h, b_j, l_j, active_rep)$ to each p_j , where b_j is the j -th Merkle tree branch

upon receiving $init(h, b_i, l_i, active_rep)$ from p_{sender}
broadcast $witness(h, b_i, l_i, active_rep)$

upon receiving $n_1 - 2f$ valid $witness(h, b_j, l_j, active_rep)$
interpolate $\{l'_j\}$ from the $n_1 - 2f$ blocks
recompute Merkle root h' and if $h' \neq h$ then abort
if $witness(h, b_i, l_i, active_rep)$ has not been sent
broadcast $witness(h, b_i, l_i, active_rep)$

upon receiving $n_1 - f$ valid $witness(h, b_j, l_j, active_rep)$
send $ready(h, b_i, l_i)$ to $2f$ learners
 $m \leftarrow decode(\{l_j\})$ {from any $n_1 - 2f$ blocks}
deliver (m)

upon receiving $n_1 - f$ valid $ready(h, \cdot, \cdot)$ {learners}
 $m \leftarrow decode(\{l_j\})$
deliver (m)

Fig. 7. MBC-L in MiB7. A message (h, b_i, l_i) is valid, if b_j is a valid Merkle tree branch for the Merkle tree root h and the data block l_j .

We show in Figure 6 and Figure 7 the workflow and pseudocode of MBC-L, respectively. Assuming $n = 7f + 1$ replicas, we have $5f + 1$ replicas are active replicas and the other $2f$ replicas are learners. (We describe the selection principle shortly.) To broadcast a message, a broadcaster p_i runs MBC to broadcast its input m among active replicas. When an active replica p_j delivers a message, it broadcasts a ready message to all learners. When a learner receives at least $4f + 1$ valid ready messages from active replicas, it recovers the value m and delivers it.

In the MiB7 environment, all replicas are active in the ABA phase. Namely, each replica votes for 1 for an ABA instance after it delivers a value in the RBC phase regardless of whether it is an active replica or a learner. Each replica waits until at least

$n - f$ ABA instances terminate with 1 before invoking other ABA instances with 0 as input.

Our approach is generic. If there is a RBC that requires n_1 replicas (e.g., tolerating $f_1 = \lfloor \frac{n_1-1}{3} \rfloor$ failures) and an ABA that requires n_2 replicas (e.g., tolerating $f_2 = \lfloor \frac{n_2-1}{5} \rfloor$ failures) where $n_2 > n_1$, then some $n_2 - n_1$ replicas are designated as learners who do not actively participate in RBC but later participate in ABA. The system tolerates f_2 failures. The n_1 replicas need to run RBC to deliver messages. When one of the n_1 replicas delivers a message, it forwards the message to all learners. A learner delivers a message when it receives $n_1 - f_2$ matching messages and then enters the ABA phase.

In the ACS framework, n parallel RBC instances are run concurrently. The principle of selecting active replicas is pretty arbitrary, as long as the system designer takes into account load balancing. For instance, in a system with replicas $\{p_0, \dots, p_{n-1}\}$, the system designer can ask p_i ($i \in [0, \dots, n-1]$) to deterministically select replicas $\{p_i, \dots, p_{(i+5f) \bmod 7f}\}$. One could ask replicas to randomly select $5f + 1$ replicas among all replicas, but the strategy is no better than the above-mentioned deterministic strategy that enables strictly even load balancing when n concurrent RBC instances are run.

While MBC-L has one more step than MBC, MBC-L in fact greatly reduces the number of messages in MiB7. As mentioned earlier, the total number of messages in MBC is $n^2 + n$. Assuming $n = 7f + 1$, the total number of messages for MBC is $49f^2 + 21f + 2$. In MBC-L we use for MiB7, there are $2f$ learners. Each MBC-L instance involves $n - 2f$, $(n - 2f)^2$, and $2f(n - 2f)$ messages in the init, witness, and ready steps, respectively. The total number of messages for MBC-L is $35f^2 + 17f + 2$.

Theorem 2. MBC-L in Figure 7 is a reliable broadcast protocol.

Proof: Validity and integrity hold by inspection of the protocol. We focus on agreement, showing that if a correct replica p_i delivers m then a correct replica p_j eventually delivers m . We distinguish several cases:

Case 1: both p_i and p_j are active replicas. In this case, agreement follows trivially from that of MBC.

Case 2: p_i is an active replica and p_j is a learner. If p_i delivers a message m with some h , then according to the agreement property of the underlying MBC, all correct replicas will deliver m with the same h . These replicas will broadcast ready messages and eventually all learners will receive $n_1 - f$ valid ready messages. According to the property of the Merkle tree, all learners can recover and deliver the same m .

Case 3: p_i is a learner and p_j is an active replica. As p_i is a learner, it must have received $n_1 - f$ valid ready messages with matching h . This means that at least $n_1 - 2f$ active replicas have delivered the corresponding m . Due to the agreement property of underlying MBC protocol, all active replicas will deliver m .

Case 4: both p_i and p_j are learners. This is similar to Case 3. Since p_i is a learner, it must have received $n_1 - f$ valid ready messages with the matching h . Hence, at least $n_1 - 2f$ active replicas have delivered the corresponding message m . Due to the agreement property of underlying MBC protocol, all active replicas will deliver m . These replicas will send valid ready messages so that all learners will obtain $n_1 - f$ ready messages. The learners and active replicas agree on the same h and except with negligible probability, they will obtain the same m .

This completes the proof of the theorem. \square

6.4 Other MiB Variants

We build a modular and expressive MiB framework, where we mix and match various RBC and ABA primitives to construct five additional asynchronous BFT protocols with suboptimal resilience. We summarize all MiB protocols in Table 2, including two MiB5 variants (MiB5a and MiB5b) and three MiB7 variants (MiB7a, MiB7b, and MiB7c). The framework allows us to validate our theoretical design and help identify meaningful protocol trade-offs among various combinations.

Note the idea of RBC learners in MBC-L applies to the AVID broadcast for both the case of $5f + 1$ and $7f + 1$. We show in Figure 8 and Figure 9 the workflow and pseudocode for the AVID-L protocol that we use for MiB5b. In AVID-L, some $3f + 1$ replicas are active replicas and the rest of replicas are learners. A broadcaster p_i applies erasure coding to generate blocks for input m and broadcasts each block to the corresponding replica. Active replicas run AVID to deliver the input m . After the message is delivered, each active replica forwards learners the delivered message. A learner recovers the value m using blocks received and delivers m . Compared to AVID, AVID-L has one additional step but less number of messages.

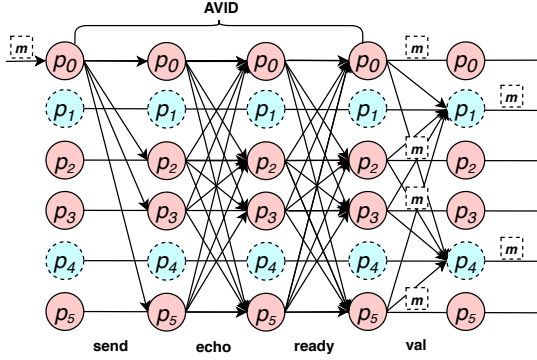

Fig. 8. The AVID-L workflow. p_0 is the broadcaster. Active replicas are denoted with solid circles and learners are represented in dashed circles.

	resilience level	ABA	RBC
MiB5	$n \geq 5f + 1$	WIS	MBC
MiB5a	$n \geq 5f + 1$	WIS	AVID
MiB5b	$n \geq 5f + 1$	WIS	AVID-L
MiB7	$n \geq 7f + 1$	SIS	MBC-L
MiB7a	$n \geq 7f + 1$	SIS	AVID
MiB7b	$n \geq 7f + 1$	SIS	MBC
MiB7c	$n \geq 7f + 1$	SIS	AVID-L

TABLE 2

MiB protocols. RBC with -L labels are protocols with learners.

7 IMPLEMENTATION AND EVALUATION

Implementation. We build MiB from the open-source prototype of BEAT library [1] written in Python. We use the BEAT0 protocol (hereinafter BEAT for simplicity) as our baseline protocol. The MiB programming framework is modular, with a unified API encompassing eight protocols—BEAT and all seven MiB protocols summarized in Table 2. We use the zfec library [3] for erasure coding. Following BEAT, for all MiB instances, we use Shoup and Gennaro threshold encryption scheme [52] and

Algorithm: AVID-L in MiB5b (Replica p_i)

upon input(m) {if $p_{sender} = p_i$ }
 $active_rep \leftarrow n_1 = 3f + 1$ active replicas
let l_j be the j -th block of $(n_1 - 2f, n_1)$ erasure coding scheme applied to m
 h is the Merkle tree root of $\{l_j\}_{j \in [0..n_1]}$ blocks
send $send(h, b_j, l_j, active_rep)$ to each p_j , where b_j is the j -th Merkle tree branch

upon receiving $send(h, b_j, l_j, active_rep)$ from p_{sender}
broadcast $echo(h, b_j, l_j, active_rep)$

upon receiving $echo(h, b_j, l_j, active_rep)$ from p_j
check if b_j is a valid Merkle tree branch for h and l_j
check whether i is in $active_rep$

upon receiving valid $echo(h, \cdot, \cdot)$ from $n_1 - f$ distinct parties
interpolate $\{l'_j\}$ from any $n_1 - 2f$ leaves received
recompute Merkle root h' and if $h' \neq h$ then abort
if $read(h)$ has not been sent
broadcast $ready(h, active_rep)$

upon receiving $f + 1$ $ready(h, active_rep)$ from p_j
if $ready(h)$ has not yet been sent
broadcast $ready(h, active_rep)$

upon receiving $2f + 1$ $ready(h, active_rep)$ from p_j
send $val(h, b_i, l_i)$ to $2f$ learners
 $m \leftarrow decode(\{l_j\})$
deliver(m)

upon receiving $n_1 - f$ valid $val(h, \cdot, \cdot)$ {learners}
 $m \leftarrow decode(\{l_j\})$
deliver(m)

Fig. 9. AVID-L in MiB5b.

the CKS threshold PRF [20] as the threshold encryption and the coin-flipping protocol, respectively. We use the prime256v1 curve with 128-bit security for the above two threshold cryptographic primitives. All the crypto schemes are implemented using the Charm Python crypto library [7].

Evaluation overview. We deploy the MiB protocols and BEAT on Amazon EC2 and evaluate their performance utilizing up to 140 instances distributed evenly in five continents. By default, we use the *t2.medium* type instances. Each instance has two virtual CPUs and 4GB memory. For one set of experiments, we also evaluate the peak throughput using *t2.micro* instances, each of which has one virtual CPUs and 1GB memory. The size of each transaction is 250 bytes. In every epoch, each replica proposes $b = \lceil B/n \rceil$ transactions, where B is the batch size.

We distinguish two scenarios: *the same n setting* and *the same f setting*. The same n setting allows evaluating the performance of all protocols with the same total number of replicas. In a system with n replicas, BEAT tolerates $\lfloor \frac{n-1}{3} \rfloor$ failures, MiB5 and its variants tolerate $\lfloor \frac{n-1}{5} \rfloor$ failures, and MiB7 and its variants tolerate $\lfloor \frac{n-1}{7} \rfloor$ failures. In our evaluation, we choose $n = 16, 31$, and 46 . For instance, when $n = 31$, BEAT tolerates 10 failures, MiB5 and its variants tolerate 6 failures, and MiB7 and its variants tolerate 4 failures. The same n setting can provide guidance for selecting protocols when one has a fixed number of nodes for an application. For instance, if one has 31 nodes and is certain there would not be 6 failures, he or she may favor MiB5 over BEAT for performance considerations.

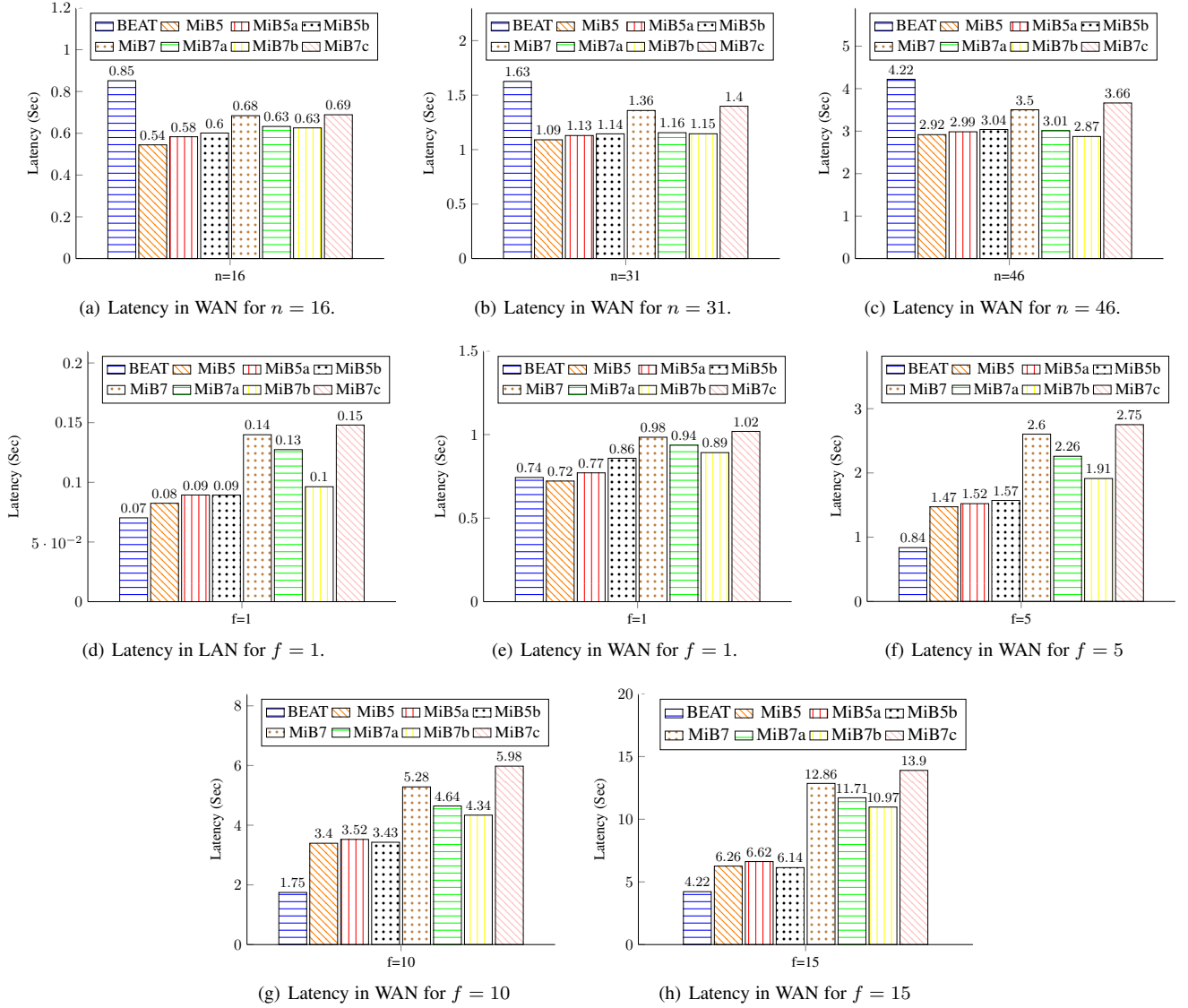

Fig. 10. Latency of MiB protocols and BEAT in both LAN and WAN settings.

The same f setting enables us to assess the performance for systems tolerating the same number of failures f . In this setting, the total number of replicas for BEAT, MiB5 and its variants, and MiB7 and its variants is $3f + 1$, $5f + 1$, and $7f + 1$, respectively. The evaluation for the same f setting is important for three reasons. First, when one designs systems with a particular goal of tolerating some f failures, the evaluation can be directly used as a guideline. In many cases, one may not wish to adopt a system with fewer replicas, as other systems with more replicas may be more efficient. Second, it helps understand the performance difference among MiB5 and its variants, as well as the difference among MiB7 and its variants. Indeed, such an evaluation allows comparing protocols with different RBC and ABA components, thereby validating our theoretical design. Third, it enables us to analyze some corner cases: for instance, if one has 6 nodes, the system can only tolerate $f = 1$ failure, whether using BEAT or MiB5. The evaluation for the $f = 1$ case can help users to understand the trade-offs.

For some experiments, we vary the size of b from 1 (250 bytes per replica) to 10000 (2.38 MB per replica) to evaluate the

throughput. We evaluate the latency when there is no contention, i.e., when $b = 1$. We evaluate the performance in the LAN settings (where the nodes are launched in the same EC2 region) and the WAN settings (where the nodes are evenly distributed in five continents).

7.1 Latency

The same n . We first compare the latency of the protocols in the WAN setting when n is fixed. As shown in Figure 10(a-c), all MiB protocols have significantly lower latency than BEAT. This is expected, since all MiB protocols terminate in fewer steps than BEAT (for both the best-case and average-case scenarios). For instance, when $n = 16$, the latency of MiB5 is 63.5% of that in BEAT. When we have a larger n , the difference between BEAT and MiB5 is more visible. For $n = 46$, the latency of MiB5 is 69.1% of that in BEAT.

MiB7 and its variants have consistently higher latency than MiB5 and its variants. When $n = 16$, the latency of MiB7 is 25.9% higher than MiB5. This is mainly because replicas need to collect more matching messages in both RBC and ABA phases.

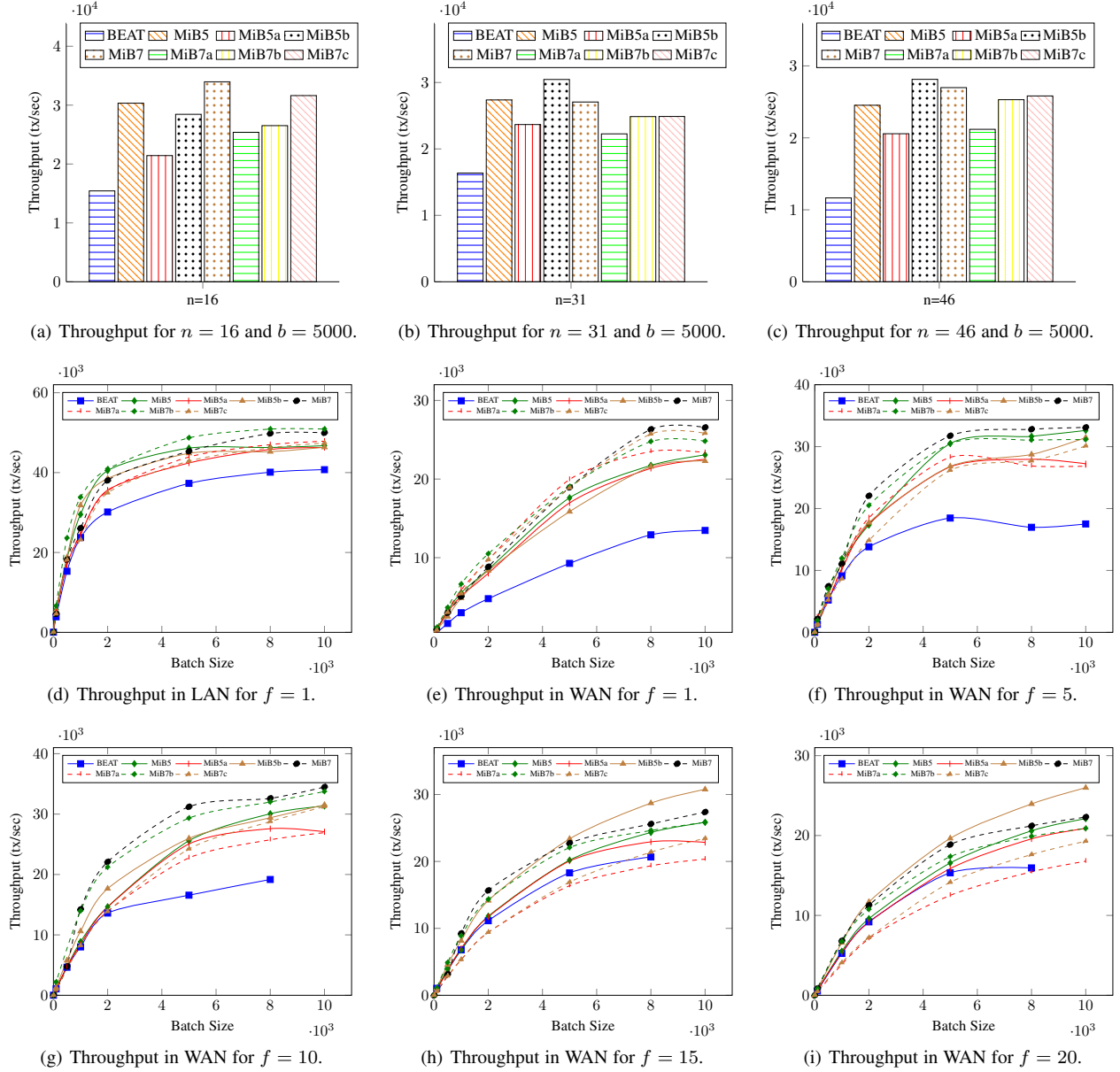

Fig. 11. Throughput of MiB protocols and BEAT in the LAN and WAN settings.

MiB7 protocols need to collect increasingly more messages when n grows larger and the latency difference between the MiB7 instance and MiB5 is more significant.

We find that the two MiB5 variants have consistently higher latency than MiB5. This does not hold for the MiB7 variants. Interestingly, we observe that the result depends on the size of b . When b is small, both MiB7a and MiB7b have lower latency than MiB7 and MiB7c. Indeed, both MiB7 and MiB7c are RBC with learners involving an additional step for some replicas. When b grows larger, the network bandwidth consumption dominates the overhead, and correspondingly, MiB7 and MiB7c have lower latency.

The same f . Figure 10(d-h) show the latency of the protocols in the LAN and WAN settings for the same f . Due to the upper bound on the number of EC2 instances we can launch in an EC2 region, we can evaluate the latency in the LAN setting only when $f = 1$. As shown in Figure 10(d), not surprisingly, the latency for

all protocols is lower than the results in the WAN environment. BEAT has lower latency than other MiB protocols. Indeed, all MiB protocols have more replicas given the same f . For instance, when $f = 1$, MiB7 has 8 replicas, while BEAT has 4 replicas. Replicas in MiB7 and BEAT need to collect 7 and 3 matching messages in each RBC and ABA invocation, respectively. Thus, MiB7 and its variants have higher latency. The same result applies to the results in the WAN environment and when f grows larger. Specifically, all MiB7 protocols have higher latency than MiB5 and BEAT. MiB5 and its variants have higher latency than BEAT, except that MiB5a has lower latency than BEAT for the $f = 1$ case only.

7.2 Throughput

The same n . We assess the throughput of the protocols using the same n . We fix the batch size to 5000 and evaluate the throughput. As shown in Figure 11(a-c), all MiB protocols achieve

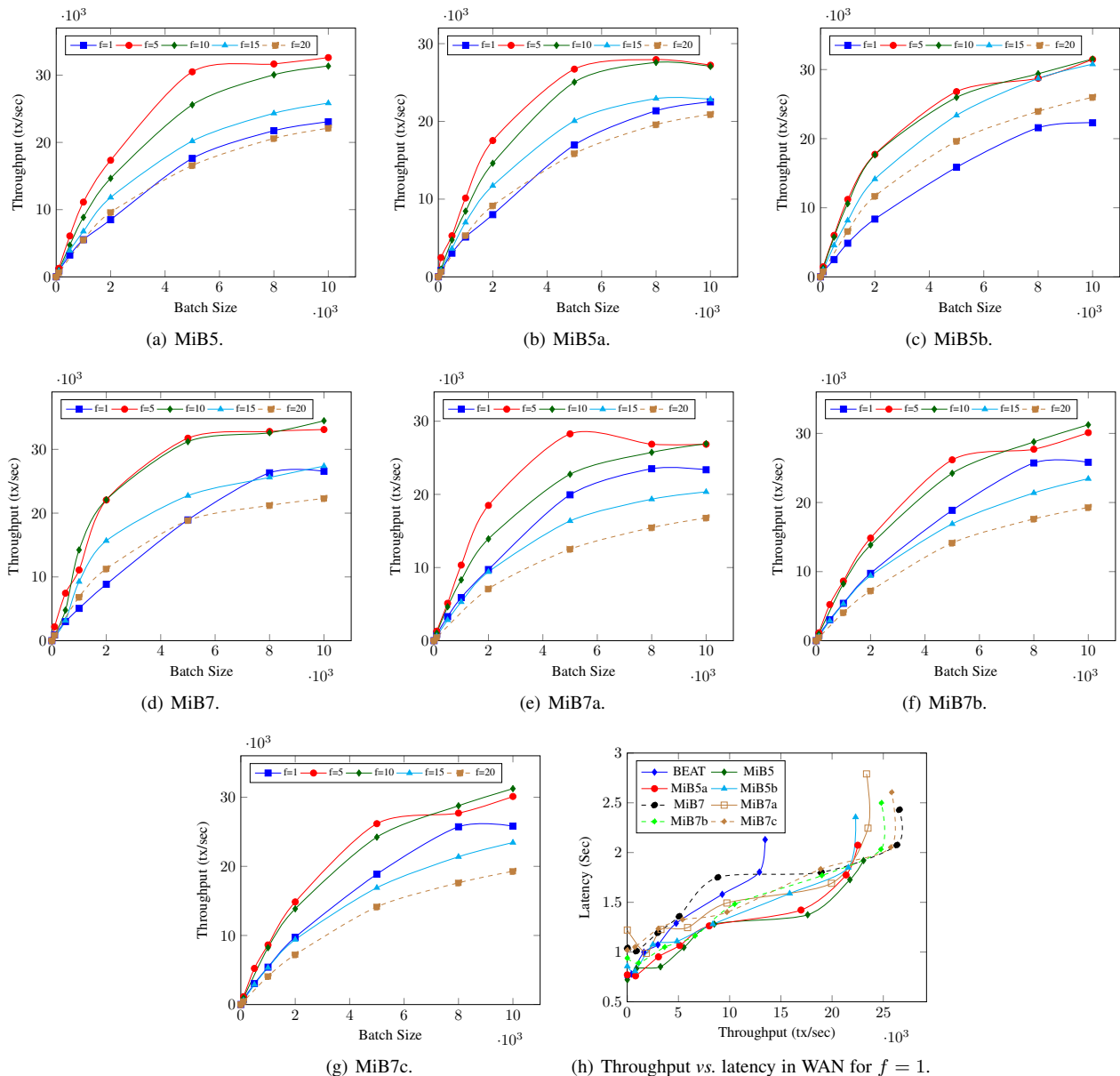

Fig. 12. (a-g) Scalability of MiB protocols; (h) throughput vs. latency in WAN.

significantly higher throughput than BEAT. As an example, when $n = 16$, the throughput of MiB5 is 96.5% higher than that of BEAT, while the throughput of MiB7 is 120.0% higher than that of BEAT. When $n = 46$, MiB5 and MiB7 achieve 110.4% and 131.5% higher throughput than BEAT, respectively. The performance improvement is mainly due to the step reduction in both the RBC and ABA components.

The same f . We report the throughput of the protocols with the same f from Figure 11(d-i). In both the LAN and WAN settings, when f is no greater than 10, all MiB protocols achieve consistently higher throughput than BEAT. Even when f is greater than 10, BEAT outperforms MiB7a and MiB7c only in some cases; other MiB protocols are consistently more efficient than BEAT. The performance difference is, in part, because MiB reduces the number of steps. Furthermore, given the same f , MiB protocols have a larger n and can propose more concurrent transactions. For instance, when $f = 1$ and $b = 5000$, the number of proposed transactions for BEAT is 33.3% and 50% less than MiB5 and MiB7, respectively. We also find that when f grows larger (when

$f \geq 15$), the network bandwidth consumption dominates the overhead and correspondingly the performance difference between BEAT and MiB protocols becomes comparatively small.

We also report in Figure 12(h) throughput vs. latency in the WAN setting for $f = 1$.

MiB5 vs. MiB7. We first report the throughput for the same n . When $n = 16$, MiB7 outperforms other protocols. When $n = 31$ and $n = 46$, MiB5b outperforms all other MiB protocols. This is expected, since both MiB5b and MiB7 use learners to reduce the number of messages transmitted. Due to the use of learners, MiB7c also achieves higher throughput among the MiB variants. The reason why MiB7c achieves lower throughput than MiB5b and MiB7 is that AVID has one more step than MBC.

For all experiments, MiB5a and MiB7a achieve lower throughput than the other MiB protocols. Note MiB5a and MiB7a use AVID and do not use learners; AVID has one more step and more messages than MBC.

We also evaluate the performance using the same f . When $f = 1$ in the LAN environment, MiB7b outperforms other proto-

cols. This is mainly because more transactions are proposed with a larger n . In contrast, in the WAN setting, MiB7 outperforms other protocols when $f \leq 10$ and MiB5b outperforms other protocols when $f \geq 15$. In particular, both MiB5b and MiB7 use learners to reduce the number of messages transmitted. Furthermore, MiB7 variants in general achieve higher throughput than MiB5 variants when f is smaller than 10 and lower throughput than MiB5 variants when f is greater than 10.

MiB with learners. MiB5b, MiB7, and MiB7c use learners and

thus outperform other protocols (except for the $f = 1$ case). For instance, when $f = 1$ in the LAN setting, the peak throughput of MiB7b is 1.84% higher than MiB7. When f equals 5, 10, 15, and 20 in the WAN setting, the peak throughput of MiB7 is 6.3%, 2.2%, 5.9%, and 6.8% higher than MiB7b, respectively.

7.3 Scalability

We evaluate the scalability of all our implemented protocols by varying f from 1 to 20 and varying b from 1 to 10000. When

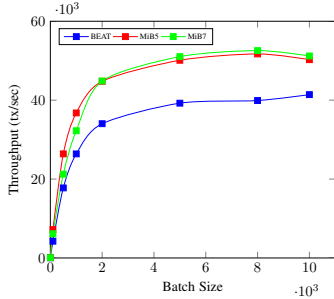

(a) Throughput in LAN for $f = 1$ in failure-free scenario.

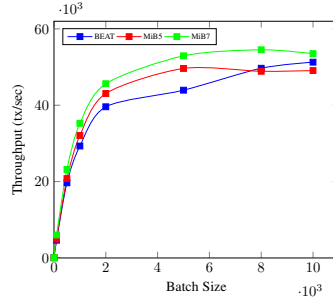

(b) Throughput in LAN for $f = 1$ in crash failure scenario.

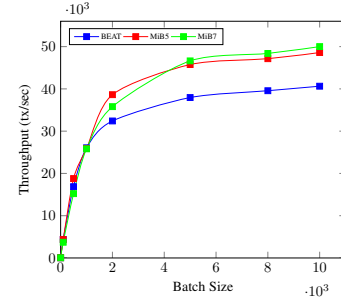

(c) Throughput in LAN for $f = 1$ in Byzantine scenario.

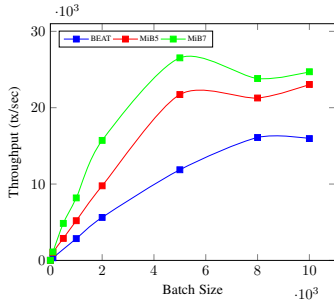

(d) Throughput in WAN for $f = 1$ in failure-free scenario.

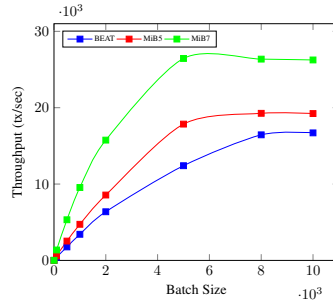

(e) Throughput in WAN for $f = 1$ in crash failure scenario.

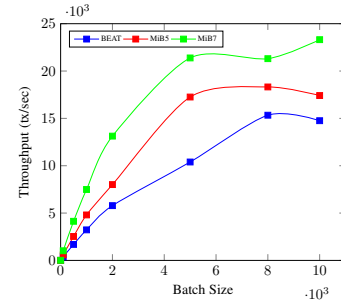

(f) Throughput in WAN for $f = 1$ in Byzantine scenario.

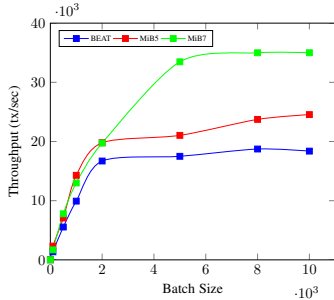

(g) Throughput in WAN for $f = 5$ in failure-free scenario.

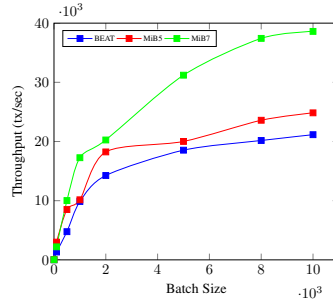

(h) Throughput in WAN for $f = 5$ in crash failure scenario.

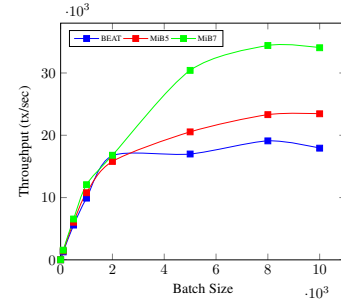

(i) Throughput in WAN for $f = 5$ in Byzantine scenario.

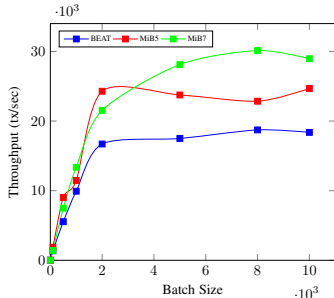

(j) Throughput in WAN for $n = 16$ in failure-free scenario.

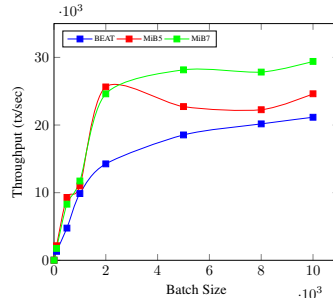

(k) Throughput in WAN for $n = 16$ in crash failure scenario.

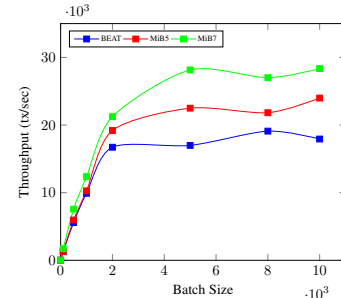

(l) Throughput in WAN for $n = 16$ in Byzantine scenario.

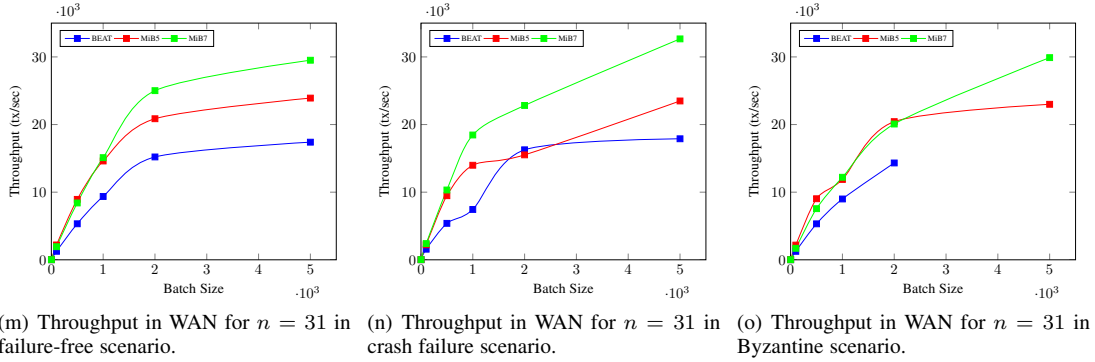

Fig. 13. Throughput of BEAT, MiB5, and MiB7 in the LAN and WAN settings in failure-free, crash failure, and Byzantine scenarios.

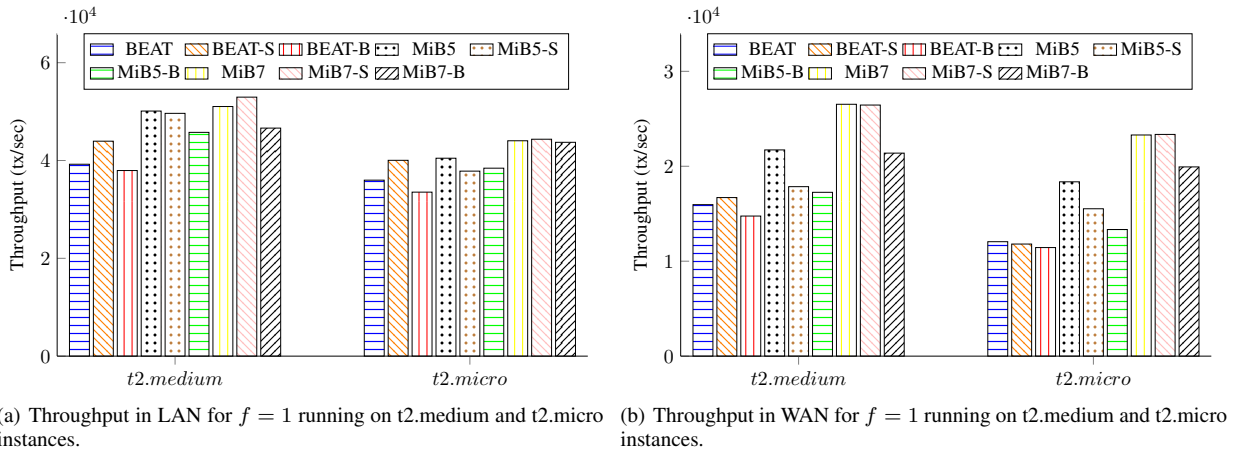

Fig. 14. Throughput of BEAT, MiB5, and MiB7 running on different hardware.

f increases from 1 to 20, the throughput first increases and then decreases. As illustrated in Figure 12, MiB protocols achieve their peak throughput around $f = 5$ and $f = 10$. The trend is very similar to that of BEAT (and EPIC): when f increases, the number of proposed transactions also increases so the throughput becomes higher; when f further increases, the network bandwidth becomes the performance bottleneck.

7.4 Performance under Failures

We now evaluate the performance of the protocols under failures. In Figure 13, we show the throughput of BEAT, MiB5 and MiB7 in three different scenarios: failure-free, crash failure, and Byzantine. In the crash failure scenario, we stop f replicas and run the protocols. In the Byzantine scenario, we chose to *simulate* the Byzantine behavior in the ABA phase instead of the RBC phase, because asynchronous RBC protocols are incredibly robust against Byzantine failures (see [21]). For the ABA phase, a Byzantine replica may exhibit either of the two following behaviors: not sending ABA proposals, or sending inconsistent proposals to different replicas. The former has been captured by the crash failure scenario. Hence, we focus on the latter one for Byzantine scenarios, where we let Byzantine replicas propose inconsistent values in the ABA phase. Note that inconsistent votes from Byzantine replicas may cause the protocols to terminate using more rounds, a strategy that might impact performance. Meanwhile, in this scenario, the ABA phase in both MiB5 and MiB7 would switch to a slower protocol, which may further reduce performance. We

vary f from 1 to 10 in WAN to evaluate the performance. For $f = 1$, we also evaluate the throughput in LAN.

Failure-free vs. crash failure. All the three protocols achieve higher throughput in the crash failure scenario than that in the failure-free scenario. For instance, the throughput of BEAT in crash failure scenario is 4.6%-24.5% higher than that in failure-free scenario. The throughput of MiB5 in crash failure scenario is 0.3%-9.4% than that in the failure-free scenario. For MiB7, the throughput is 1.5%-10.6% higher in the crash failure scenario than the failure-free scenario. The results are expected, since the network bandwidth consumption is lower when f replicas crash compared to the failure-free scenario. Compared to BEAT, the throughput improvement under crash failures for both MiB5 and MiB7 are lower. This is because both MiB5 and MiB7 achieve one-step termination in the failure-free cases for over $n - f$ ABA instances. In contrast, in the crash failure scenario, both protocols switch to a slower backup ABA protocol under failures.

Failure-free vs. Byzantine. For all the experiments, all the three protocols achieve higher throughput in the failure-free scenario than the Byzantine scenario. The throughput of BEAT in failure-free scenario is 1.9%-4.9% higher than that in the Byzantine scenario. For MiB5, the throughput is 2.9%-16.1% higher in the failure-free scenario. The throughput of MiB7 is 2.2%-6.0% higher in the failure-free scenario. The results are also expected since faulty replicas broadcast inconsistent messages to all replicas so the network bandwidth consumption is higher than that in the failure-free scenario. The degradation of performance under

Byzantine failures for MiB5 and MiB7 is higher compared to that in BEAT. This is because both protocols switch to a backup ABA under failures.

Performance using different hardware. We assess the performance of the protocols using both *t2.medium* instances and *t2.micro* instances. We show the peak throughput of BEAT, MiB5, and MiB7. For each protocol, we evaluate the peak throughput under failure-free, crash failure, and Byzantine scenarios. For each protocol, we use protocol name to represent the performance in failure-free scenario, -S to represent the performance of the crash failure scenario, and -B to represent the performance of the Byzantine scenario. We show the performance in Figure 14.

All the protocols achieve higher throughput using *t2.medium* instances. This is expected since all the computational operations are faster. In the LAN setting, the performance improvement BEAT in all three scenarios are consistency lower than that in the WAN setting. For instance, BEAT, BEAT-S, and BEAT-B achieve 9.0%, 9.8%, and 13.1% higher throughput using *t2.medium* than that in *t2.micro* in LAN, separately. In the WAN setting, the throughput are 32.3%, 41.5%, and 29.0% higher in the three scenarios. In contrast, the performance improvement for both MiB5 and MiB7 are in general higher in the WAN setting. For instance, MiB5 achieves 23.8% and 18.3% higher throughput using *t2.medium* in LAN and WAN, separately. MiB7 achieves 15.9% and 13.2% higher throughput using *t2.medium* in LAN and WAN, separately. This is mainly because both MiB5 and MiB7 involve more replicas ($5f + 1$ and $7f + 1$) so the network bandwidth consumption dominates the overhead of the protocols.

8 CONCLUSION

We study two important directions in asynchronous BFT—BFT with suboptimal resilience and BFT performance under failures and attacks. This paper provides MiB, a novel and efficient asynchronous BFT framework using new distributed system constructions as building blocks (including an erasure-coded version of IR RBC and a learner-version of RBC). MiB consists of two main BFT instances and five other variants. We design experiments with failures and systematically evaluate the performance of asynchronous BFT protocols (including MiB) in crash failure and Byzantine failure scenarios. Via a five-continent deployment using 140 replicas, we show the MiB instances have lower latency and much higher throughput than their asynchronous BFT counterparts, and moreover, asynchronous BFT protocols, including our MiB protocols, are indeed robust against failures and attacks.

REFERENCES

- [1] BEAT library. <https://github.com/fififish/beat>.
- [2] Bug in ABA protocol’s use of common coin. <https://github.com/amiller/HoneyBadgerBFT/issues/59>.
- [3] Zfec library. <https://pypi.python.org/pypi/zfec>.
- [4] M. Abd-El-Malek, G. R. Ganger, G. R. Goodson, M. K. Reiter, and J. J. Wylie. Fault-scalable Byzantine fault-tolerant services. *ACM SIGOPS Operating Systems Review*, 39(5):59–74, 2005.
- [5] I. Abraham, D. Malkhi, K. Nayak, L. Ren, and A. Spiegelman. Solida: A blockchain protocol based on reconfigurable Byzantine consensus. In *OPODIS*, 2017.
- [6] I. Abraham, D. Malkhi, and A. Spiegelman. Validated asynchronous Byzantine agreement with optimal resilience and asymptotically optimal time and word communication. *arXiv preprint arXiv:1811.01332*, 2018.
- [7] J. A. Akinyele, C. Garman, I. Miers, M. W. Pagano, M. Rushanan, M. Green, and A. D. Rubin. Charm: a framework for rapidly prototyping cryptosystems. *J. Cryptographic Engineering*, 3(2):111–128, 2013.
- [8] M. Ben-Or. Another advantage of free choice: Completely asynchronous agreement protocols (extended abstract). In *PODC*, pages 27–30, 1983.
- [9] M. Ben-Or, B. Kelmer, and T. Rabin. Asynchronous secure computations with optimal resilience. In *Proceedings of the 13th annual symposium on Principles of distributed computing*, pages 183–192. ACM, 1994.
- [10] P. Berman and J. A. Garay. Randomized distributed agreement revisited. In *FTCS-23 The Twenty-Third International Symposium on Fault-Tolerant Computing*, pages 412–419. IEEE, 1993.
- [11] G. Bracha. An asynchronous $[(n-1)/3]$ -resilient consensus protocol. In *Proceedings of the third annual ACM symposium on Principles of distributed computing*, pages 154–162. ACM, 1984.
- [12] G. Bracha. Asynchronous Byzantine agreement protocols. *Information and Computation*, 75(2):130–143, 1987.
- [13] M. Burrows. The chubby lock service for loosely-coupled distributed systems. In *Proceedings of the 7th symposium on Operating systems design and implementation*, pages 335–350. USENIX Association, 2006.
- [14] C. Cachin, K. Kursawe, F. Petzold, and V. Shoup. Secure and efficient asynchronous broadcast protocols. In *Annual International Cryptology Conference*, pages 524–541. Springer, 2001.
- [15] C. Cachin, K. Kursawe, and V. Shoup. Random oracles in constantinople: Practical asynchronous Byzantine agreement using cryptography. *Journal of Cryptology*, 18(3):219–246, 2005.
- [16] C. Cachin and J. A. Poritz. Secure intrusion-tolerant replication on the internet. In *DSN*, pages 167–176. IEEE, 2002.
- [17] C. Cachin and S. Tessaro. Asynchronous verifiable information dispersal. In *SRDS*, pages 191–201. IEEE, 2005.
- [18] R. Canetti and T. Rabin. Fast asynchronous Byzantine agreement with optimal resilience. In *STOC*, volume 93, pages 42–51. Citeseer, 1993.
- [19] M. Castro and B. Liskov. Practical Byzantine fault tolerance and proactive recovery. *ACM Transactions on Computer Systems (TOCS)*, 20(4):398–461, 2002.
- [20] C. Christian, K. Klaus, and S. Victor. Random oracles in constantinople: Practical asynchronous byzantine agreement using cryptography. *Journal of Cryptology*, 18:3, 2005.
- [21] D. Collins, R. Guerraoui, J. Komatovic, P. Kuznetsov, M. Monti, M. Pavlovic, Y. Pignolet, D. Seredinschi, A. Tonkikh, and A. Xygiakis. Online payments by merely broadcasting messages. In *DSN*, pages 26–38. IEEE, 2020.
- [22] M. Correia, N. F. Neves, and P. Verissimo. From consensus to atomic broadcast: Time-free Byzantine-resistant protocols without signatures. *The Computer Journal*, 49(1):82–96, 2006.
- [23] I. Damien and R. Michel. Trading off t-resilience for efficiency in asynchronous byzantine reliable broadcast. *Parallel Processing Letters*, 26:8, 2016.
- [24] S. Duan, H. Meling, S. Peisert, and H. Zhang. BChain: Byzantine replication with high throughput and embedded reconfiguration. In *OPODIS*, pages 91–106, 2014.
- [25] S. Duan, M. K. Reiter, and H. Zhang. BEAT: Asynchronous bft made practical. In *Proceedings of the 2018 ACM SIGSAC Conference on Computer and Communications Security*, pages 2028–2041. ACM, 2018.
- [26] C. Dwork, N. Lynch, and L. Stockmeyer. Consensus in the presence of partial synchrony. *Journal of the ACM (JACM)*, 35(2):288–323, 1988.
- [27] R. Friedman, A. Mostefaoui, and M. Raynal. Simple and efficient oracle-based consensus protocols for asynchronous Byzantine systems. *IEEE Transactions on Dependable and Secure Computing*, 2(1):46–56, 2005.
- [28] B. Guo, Z. Lu, Q. Tang, J. Xu, and Z. Zhang. Dumbo: Faster asynchronous bft protocols. In *Proceedings of the 2020 ACM SIGSAC Conference on Computer and Communications Security*, 2020.
- [29] B. Guo, Z. Lu, Q. Tang, J. Xu, and Z. Zhang. Dumbo: Faster asynchronous BFT protocols. *IACR Cryptol. ePrint Arch.*, 2020:841, 2020.
- [30] P. Hunt, M. Konar, F. P. Junqueira, and B. Reed. Zookeeper: Wait-free coordination for internet-scale systems. In *USENIX annual technical conference*, volume 8. Boston, MA, USA, 2010.
- [31] E. K. Kogias, P. Jovanovic, N. Gailly, I. Khoffi, L. Gasser, and B. Ford. Enhancing bitcoin security and performance with strong consistency via collective signing. In *USENIX Security*, pages 279–296, 2016.
- [32] E. Kokoris-Kogias, P. Jovanovic, L. Gasser, N. Gailly, and B. Ford. Omniledger: A secure, scale-out, decentralized ledger. *IACR Cryptology ePrint Archive*, 2017:406, 2017.
- [33] R. Kolta, L. Alvisi, M. Dahlin, A. Clement, and E. Wong. Zyzzyva: speculative Byzantine fault tolerance. *ACM Transactions on Computer Systems*, 27(4):7:1–7:39, 2009.
- [34] K. Kursawe and V. Shoup. Optimistic asynchronous atomic broadcast. In *ICALP*, pages 204–215, 2005.
- [35] L. Leslie. Paxos made simple. In *ACM Sigact News*, 2001.
- [36] C. Liu, S. Duan, and H. Zhang. Epic: Efficient asynchronous bft with adaptive security. In *DSN*, 2020.

- [37] L. Luu, V. Narayanan, C. Zheng, K. Baweja, S. Gilbert, and P. Saxena. A secure sharding protocol for open blockchains. In *CCS*, pages 17–30. ACM, 2016.
- [38] E. MacBrough. Cobalt: Bft governance in open networks. *arXiv preprint arXiv:1802.07240*, 2018.
- [39] J.-P. Martin and L. Alvisi. Fast byzantine paxos. In *Proceedings of the International Conference on Dependable Systems and Networks*, pages 402–411, 2004.
- [40] A. Miller, Y. Xia, K. Croman, E. Shi, and D. Song. The honey badger of bft protocols. In *Proceedings of the SIGSAC Conference on Computer and Communications Security*, pages 31–42. ACM, 2016.
- [41] H. Moniz, N. F. Neves, M. Correia, and P. Verissimo. Ritas: Services for randomized intrusion tolerance. *IEEE transactions on dependable and secure computing*, 8(1):122–136, 2008.
- [42] A. Mostefaoui, H. Moumen, and M. Raynal. Signature-free asynchronous Byzantine consensus with $t < n/3$ and $o(n^2)$ messages. In *PODC*, pages 2–9. ACM, 2014.
- [43] R. Pass and E. Shi. Hybrid consensus: Efficient consensus in the permissionless model. In *DISC*, 2017.
- [44] A. Patra, A. Choudhary, and C. Pandu Rangan. Simple and efficient asynchronous Byzantine agreement with optimal resilience. In *PODC*, pages 92–101. ACM, 2009.
- [45] M. O. Rabin. Randomized byzantine generals. In *SFCS*, pages 403–409. IEEE, 1983.
- [46] H. V. Ramasamy and C. Cachin. Parsimonious asynchronous Byzantine-fault-tolerant atomic broadcast. In *OPODIS*, 2005.
- [47] Y. J. Song and R. van Renesse. Bosco: One-step Byzantine asynchronous consensus. In *International Symposium on Distributed Computing*, pages 438–450. Springer, 2008.
- [48] Y. J. Song and R. van Renesse. Bosco: One-step Byzantine asynchronous consensus. In *DISC*, pages 438–450. Springer, 2008.
- [49] T. Srikanth and S. Toueg. Simulating authenticated broadcasts to derive simple fault-tolerant algorithms. *Distributed Computing*, 2(2):80–94, 1987.
- [50] S. Toueg. Randomized byzantine agreements. In *PODC*, pages 163–178. ACM, 1984.
- [51] C. Tyler, G. Vincent, L. Mikel, and R. Michel. Dbft: Efficient leaderless byzantine consensus and its application to blockchains. In *17th International Symposium on Network Computing and Applications*, 2018.
- [52] S. Victor and G. Rosario. Securing threshold cryptosystems against chosen ciphertext attack. In *EUROCRYPT*, 1998.
- [53] M. Zamani, M. Movahedi, and M. Raykova. Rapidchain: A fast blockchain protocol via full sharding. In *CCS*, pages 931–948, 2018.
- [54] P. Zielinski. Optimistically terminating consensus: All asynchronous consensus protocols in one framework. In *ISPD*, pages 24–33. IEEE, 2006.