

Hardware-aware Design of Multiplierless Second-Order IIR Filters with Minimum Adders

Rémi Garcia, Anastasia Volkova, Martin Kumm, Alexandre Goldsztejn, Jonas Kühle

Abstract—In this work we optimally solve the problem of multiplierless design of second-order Infinite Impulse Response filters with minimum number of adders. Given a frequency specification, we design a stable direct form filter with hardware-aware fixed-point coefficients that yielding minimal number of adders when replacing all the multiplications by bit shifts and additions. The coefficient design, quantization and implementation, typically conducted independently, are now gathered into one global optimization problem, modeled through integer linear programming and efficiently solved using generic solvers. We guarantee the frequency-domain specifications and stability, which together with optimal number of adders will significantly simplify design-space exploration for filter designers.

The optimal filters are implemented within the FloPoCo IP core generator and synthesized for Field Programmable Gate Arrays. With respect to state-of-the-art three-step filter design methods, our one-step design approach achieves, on average, 42% reduction in number of lookup tables and 21% improvement in delay.

Index Terms—Digital filters, IIR, optimal design, multiplierless hardware, ILP

I. INTRODUCTION

DIGITAL filters are essential components of modern technology, from medical equipment to scientific instruments. Filter design is a core topic in digital signal processing and control, and efficient filter implementation in software and hardware has received a significant research interest for half a century. Infinite Impulse Response (IIR) filters are a class of widely-used recursive linear time-invariant filters. IIR filters can be relatively easily designed in software, but hardware implementation is essential for embedded systems, where performance/power constraints are critical. Some application domains, such as 5G/6G backbones and autonomous vehicles, rely on reconfigurable hardware using Field Programmable Gate Arrays (FPGA).

Classic Fixed-Point (FxP) filter design and implementation flow follows three separate steps:

- 1) **Filter Design (FD)** consists in finding real (in practice, double precision) filter coefficients, adhering to the given frequency specification. IIR filters are defined by coefficients of a rational transfer function, for which a stability criteria must be also satisfied. In general, a large

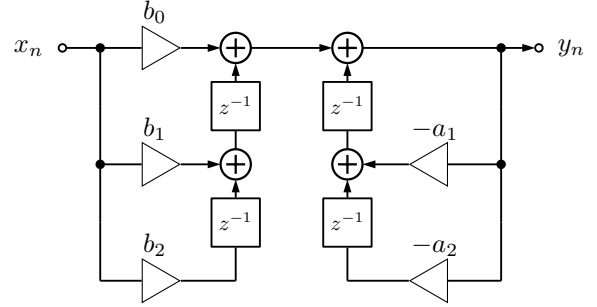

Fig. 1: Transposed Direct Form II for a second-order IIR filter.

amount of different filter coefficient sets can realize a given frequency specification;

- 2) **Quantization (Q)** converts the coefficients to a FxP format such that they still respect the given frequency response and they still lead to a stable filter;
- 3) **Implementation (I)** consists in generating, using quantized coefficients, a valid hardware description. This step exposes a high number of parameters, *e. g.*, the type of multipliers used.

The combination of FD and Q steps has been studied extensively since 1960s [1]–[3]. For certain structures of IIR filters it can even be considered solved [4], but with respect to a signal to quantization noise ratio, which is a probabilistic measure, not guaranteeing numerical safety. The general approach for quantization of a transfer function is nevertheless quite straightforward, passing through iterative increase of coefficient word length.

A large body of work exists for the I step. Hardware filters involve multiplications with constants, for which optimization techniques have been extensively explored. In the multiplierless *shift-and-add*-based methods, constant multiplications are replaced by additions, subtractions and bit shifts. The associated optimization problem is known as the multiple constant multiplication (MCM) problem, for which heuristics [5]–[7] as well as optimal approaches exist [8]–[11]. Various cost functions are possible: the high-level ones count the number of adders required to perform all multiplications, and low-level ones counting the number of full adders. This problem has been successfully modeled as (Mixed) Integer Linear Programming (ILP) and solved using efficient solvers such as CPLEX or Gurobi. Another constant multiplication method, especially relevant for FPGAs, is based on precomputed tables and is called Ken Chapman multiplier (KCM), after its inventor [12]. It has also been successfully applied to digital filtering [9],

R. Garcia and A. Volkova were with Université de Nantes, CNRS, LS2N F-44000 Nantes, France. Email: firstname.lastname@univ-nantes.fr

A. Goldsztejn was with CNRS, Université de Nantes, LS2N F-44000 Nantes, France. Email: alexandre.goldsztejn@ls2n.fr

M. Kumm and J. Kühle were with Faculty of Applied Computer Science, Fulda University of Applied Sciences, Germany. Email: firstname.lastname@informatik.hs-fulda.de

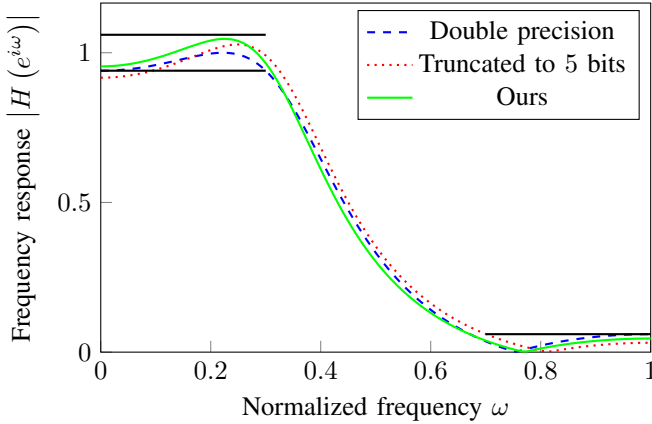

Fig. 2: An example of filter specification ($\mathbb{1}p_{14}$ in our benchmarks), for which a standard FD & Q approach fails to find 5-bit coefficients, while our approach succeeds.

[13], [14] and using this method, an approach for optimization of combined Q & I steps has been proposed [15].

Both KCM and shift-and-add reduce arithmetic resources by sharing intermediate results. However, this reduction strongly depends on the coefficient values, which are typically fixed in the previous FD & Q steps. Hence, the obtained implementations are optimized only for one filter instance, or a small sub-set of the overall design space, not permitting overall optimal solution.

The most common model in formation of IIR filters is based on the decomposition of a higher-order filter into a cascade of second-order sections implemented with the Direct Form structure [3], [16]–[19]. We focus here on the optimal design of individual second-order filters (see Fig. 1) as a building brick for methods using cascaded forms, *e. g.*, [20]. Our ambition is to solve the **combined FD & Q & I steps for a second-order IIR within one global optimization**. Even for one second-order filter this is a difficult non-linear combinatorial problem. Recent work [20] attempts to solve the IIR filter design and cascading problem, while targeting coefficients with the minimal binary writing, but does not lead to optimal solutions due to restricted design-space and a heuristic solver.

In contrast, in this paper we model the overall process as an ILP problem, which is consequently optimally solved using generic solvers. With this work, the whole design space for the FD & Q & I problem is covered: we search for FxP coefficients (*i. e.*, the quantization stage is implicit) that satisfy filter specifications while minimizing the cost of both structural and multiplier blocks in a multiplierless Transposed Direct Form II realization of a second-order IIR filter. We focus on the transposed form, as it allows to model the multiplications of the input/output by filter coefficients as the MCM problem based on ILP. Fig. 2 exhibits an example of filter specifications, for which the standard FD & Q step does not find 5-bit coefficients satisfying the constraints, whilst our approach easily finds the coefficients that need only 8 adders.

The proposed ILP formulation is building upon the optimal MCM [11] solution for constant multiplications. While dif-

ferent cost functions are possible, we start with a high-level metric counting number of adders, leaving the low-level metric of counting the full adders out of scope.

A similar approach has been recently proposed for optimizing the number of adders for FIR filters [21] but extending its ideas towards IIR filters requires overcoming several challenges: expressing the filter design constraints for a rational transfer function in a linear way, guaranteeing the stability and determining the FxP format for multiplier blocks, which are described in Section II. Moreover, we present a design-space reduction that significantly improves the solving time. As a result, we provide an automatic tool that, given frequency specifications and word length, within mere seconds determines the FxP filter coefficients that guarantee the minimal number of adders for a multiplierless implementation, as well as the multiplierless solution for each coefficient block. We validate our approach on real-life and artificial examples in Section III by automatically generating and synthesizing VHDL code on FPGA targets.

II. ILP FORMULATION FOR SECOND-ORDER IIR FILTER DESIGN

A. Problem Definition

Transposed Direct Form II structure of second order digital filters is represented in Fig. 1. Its output is computed as

$$y_n = \sum_{k=0}^2 b_k u_{n-k} - \sum_{k=1}^2 a_k y_{n-k}, \quad (1)$$

where $a_k, b_k \in \mathbb{R}$ are the filter coefficients. The corresponding transfer function is

$$H(z) = \frac{B(z)}{A(z)} = \frac{b_0 + b_1 z^{-1} + b_2 z^{-2}}{1 + a_1 z^{-1} + a_2 z^{-2}}, \quad (2)$$

with $z \in \mathbb{C}$. Designing a filter means finding the coefficients a_k and b_k such that the filter is stable and given frequency constraints hold. These constraints can be expressed as bounds on the filter frequency response

$$\underline{\beta}(\omega) \leq |H(e^{j\omega})| \leq \bar{\beta}(\omega), \quad \forall \omega \in [0; \pi], \quad (3)$$

where $\underline{\beta}$ and $\bar{\beta}$ are the given frequency dependent lower and upper bounds. They typically encode constant bounds valid inside frequency intervals, but our definition (3) allows to model them as functions of ω .

There exists a large number of real-valued coefficient sets satisfying the frequency specifications (3) but only a subset of those is representable in FxP arithmetic with a given word length. In our approach, we directly search for a_k and b_k in a FxP representation and introduce their integer counterparts, $a'_k, b'_k \in \mathbb{Z}$, that are linked with the real-valued coefficients via

$$a_k = 2^{-w+1} 2^{g_a} a'_k, \quad a'_k \in [-2^{w-1}; 2^{w-1} - 1], \quad (4)$$

$$b_k = 2^{-w+1} 2^{g_b} b'_k, \quad b'_k \in [-2^{w-1}; 2^{w-1} - 1], \quad (5)$$

where w is the word length (including sign bit), g_a and g_b are the largest Most Significant Bit (MSB) positions of the FxP representations of a_k and b_k , respectively. It is typical to use the same word length for a_k and b_k but we allow

different FxP formats in the numerator and denominator of the transfer function. The optimal design process proposed here is cast into the integer programming framework by searching for the integer counterparts a'_k and b'_k within the set of all representable numbers defined by w , g_b and g_a . While the word length w is a user-given parameter in our setting and is typically desired to be as small as possible in order to save resources¹, the values of the MSB positions g_b and g_a are not known. Hence, in order to provide an ILP model one must first predict the precision and the range of the FxP coefficients. This task is more challenging for IIR filters compared to FIR filters, where the MSB positions can be set to 0 and afterwards controlled through the filter gain. More precisely, the goal is to predict the MSB positions that, on the one hand, encompass all representable coefficients, *i. e.*, do not lose solutions, and that maximize the precision, *i. e.*, do not overestimate the MSB, on the other hand. We find upper bounds for g_a and g_b via a pre-processing routine described in Section II-C. Further, we solve our model for a range of lower MSBs with an external loop.

As it has been successfully done for FIR filters [21], we unify the filter coefficients design and their quantization by searching directly for coefficients satisfying the frequency constraints in their FxP representation: the overall objective is to find FxP representations of filter coefficients such that filter specifications are met and the hardware implementation is optimal with respect to the number of adders. Extending this approach from FIR to IIR filters requires several technical contributions: the frequency constraints (3) on the complex modulus of the rational transfer function (2) involve highly nonlinear operations, which are linearized in Section II-B. We express stability constraints over the FxP coefficients and determine the MSB positions for coefficients a_k and b_k in Section II-C. Search space reductions are presented in Section II-E. The connection of filter specification constraints with two standard MCM ILP models for its multiplierless implementation is presented in Section II-D. Finally, a short summary of the workflow is presented in Section II-F.

B. Formulating Linear Frequency Constraints

In order to obtain an ILP model, we have to solve two issues related to the frequency constraints (3). First of all, (3) actually enforces one constraint for each $\omega \in [0; \pi]$. There are infinitely many such constraints to be satisfied. The constraint (3) is called semi-infinite (see [22] for a survey on this class of constraints). The standard discretization approach to handling semi-infinite constraints consists in discretizing $[0; \pi]$ into a finite set of frequencies Ω_d , leading to a finite number of constraints. This discretization can be dynamically updated, but we consider here a fixed discretization and a *a posteriori* verification of the semi-infinite frequency constraint [23]. In the rare cases where the verification fails, the verification procedure proposed in [23] outputs a faulty frequency that can be added to the discretized set of frequencies for a new trial. Continuous variables generically lead to active constraints, which require some theory and accurate algorithms with some

adaptive discretization to allow discovering active frequencies for optimal coefficients (see [22], [24] for details). Integer variables generically do not lead to active constraints. This means that only a finite number of faulty frequencies can happen after the ILP design, before we obtain coefficients verifying rigorously the frequency specifications. This reduction to a finite problem of the semi-infinite constraint is a positive side effect of searching directly FxP representations of the coefficients.

After this discretization of the semi-infinite constraint, a finite number of nonlinear constraints needs to be handled. For a fixed $\omega \in \Omega_d$, the constraint (3) includes a complex absolute value, which involves a square-root of the sum of squared terms, and a fraction. By incorporating (2) into (3), then multiplying with the denominator $|A(e^{j\omega})|$, and finally squaring the result we obtain a constraint equivalent to (3)

$$|A(e^{j\omega})|^2 \underline{\beta}(\omega)^2 \leq |B(e^{j\omega})|^2 \leq |A(e^{j\omega})|^2 \bar{\beta}(\omega)^2, \quad (6)$$

where,

$$|B(e^{j\omega})|^2 = \sum_{k=0}^2 \sum_{l=0}^2 b_k b_l \cos((k-l)\omega), \quad (7)$$

$$|A(e^{j\omega})|^2 = \sum_{k=0}^2 \sum_{l=0}^2 a_k a_l \cos((k-l)\omega), \quad \text{with } a_0 = 1. \quad (8)$$

Yet, in (7) and (8), the filter coefficients are still involved in bilinear terms $b_k b_l$ and $a_k a_l$. Billionnet *et al.* [25] proposed a method that allows linearizing products of positive integers assuming that bounds on these numbers are known: consider the product $z = xy$ where $x, y, z \in \mathbb{N}$, with $x \leq \bar{x}$ and $y \leq \bar{y}$. The linearization [25] basically consists in first rewriting one of the positive integers into its binary representation

$$x = \sum_{i=0}^{\lceil \log_2 \bar{x} \rceil + 1} 2^i t_{x,i}, \quad (9)$$

where $t_{x,i}$ are binary auxiliary variables. This constraint ensures that the bits $t_{x,i}$ encode the value of x . Then, the product $z = xy$ becomes a sum of products between the binary variables $t_{x,i}$ and the positive integer y . Finally, such a binary by integer product is common and its well-known linearization involves indicator or big M constraints [26], [27].

Here however, x and y correspond to filter coefficients that have no sign restriction. We extend the linearization exposed above to signed integers by adding the auxiliary variables $x^+, y^+ \in \mathbb{N}$ and $x^{\text{sg}}, y^{\text{sg}} \in \{0, 1\}$, and link them by following constraints

$$x^+ = |x|, \quad y^+ = |y|, \quad (10)$$

$$x^{\text{sg}} = \text{sign}(x), \quad y^{\text{sg}} = \text{sign}(y), \quad (11)$$

$$z^+ = x^+ y^+, \quad (12)$$

where the linearization of the absolute values (10) and the sign constraints (11) are well-known and involve indicator or big M constraints [28], [29], and where $z^+ = x^+ y^+$ is the positive case we already presented. Finally, $z = \pm z^+$ and the sign is determined by the values of x^{sg} and y^{sg} directly in the model. This whole linearization relies on the fact that bounds on x and y are known. This is addressed in the next subsection.

¹In Section III-D we demonstrate that smaller coefficient word lengths do not necessarily lead to smaller resource consumption.

C. Stability and Bounds on Filter Coefficients

Necessary and sufficient stability conditions for second-order filters are well-known [30, Section 16.8] to be

$$-2 < a_1 < 2, \quad (13)$$

$$|a_1| - 1 < a_2 < 1. \quad (14)$$

As explained before, the absolute value is standardly linearized using indicator or big M constraints, thus (13)-(14) actually fit in an ILP model. From these constraints it is straightforward to derive bounds on a_k : $a_1 \in]-2; 2[$ and $a_2 \in]-1; 1[$. These bounds are independent of the frequency specification of the filter and yield an upper bound, $g_a = 1$, for the MSB of the coefficients a_k .

Bounds on b_k , however, cannot be obtained independently of the filter specifications. Using the bounds (13)-(14) and the fact the cosine in (8) belongs to $[-1; 1]$, we deduce that $|A(e^{j\omega})|^2 \leq 16$. This bound together with the frequency specification constraints (6) lead to the constraint

$$|B(e^{j\omega})|^2 \leq 16\bar{\beta}(\omega)^2, \quad (15)$$

that needs to be satisfied by the coefficients b_k .

As can be seen from (7), $|B(e^{j\omega})|^2$ is a quadratic form $b^T Q b$ with respect to the variables b_k . Its characteristic matrix Q , whose entries are $Q_{kl} = \cos((k-l)\omega)$, is symmetric and its spectrum is $\{0, 1 - \cos(2\omega), 2 + \cos(2\omega)\}$. Its eigenvalues being non-negative, the inequality constraint (15) is convex. As a consequence, some lower and upper bounds on the coefficients b_k can be computed by solving the convex quadratic problems consisting in minimizing or maximizing b_k subject to the convex quadratic constraints (15) for all frequencies $\omega \in \Omega_{d'}$ where $\Omega_{d'}$ is a discretization of Ω . The global minimum and maximum of these problems are required to be used as valid lower and upper bounds, such global extrema being easily computed by local solvers since the quadratic constraints are all convex and the cost is linear. In particular, common mixed ILP solvers can solve this kind of nonlinear problem. In addition to allowing the linearization of frequency constraints, these bounds permit to decide a first upper bound, g_b , for the MSB of the coefficients b_k .

These bounds do not fully take into account the specificity of the filter we are designing and use the worst case bounds in (15). In any case, it is possible to compute tighter bounds on the coefficients in order to reduce the search space as explained in Section II-E.

D. MCM for Direct-Form IIR Filters

The FxP coefficients satisfying the above frequency and stability constraints are also subject to hardware constraints. We use the ILP-based hardware models for optimal multiplierless constant multiplication presented in [10], [11] that can be readily incorporated into our problem. These models, given a set of constant coefficients, solve the minimization (w. r. t. number of adders) or satisfiability (whether an implementation with a given number of adders is feasible) problems. For the global IIR filter design problem, the coefficients are, however, the unknowns. Hence, the first task is designing a number of

linking constraints that bind the coefficient variables for filter design with the inputs of an MCM problem. We achieve this by introducing a number of binary variables and refer to them as *glue constraints* in Fig. 3.

It should be noted, that two sets of MCM constraints must be designed, as there is one multiplier block for coefficients a_k and one for b_k , with the goal of minimization of the *total* number of adders, *i. e.*, in both multiplier blocks and in the filter structure. The final cost function for the adder minimization ILP formulation is then

$$\min A_{M_a} + A_{M_b} - \sum_{k=0}^2 \zeta_k^b - \sum_{k=1}^2 \zeta_k^a, \quad (16)$$

where A_{M_a} and A_{M_b} denote the number of adders in multiplier blocks for a_k and b_k , respectively; and ζ_k^a and ζ_k^b are binary variables validating whether the respective filter coefficients are zero. In other words, the number of zero-valued coefficients is maximized, privileging sparsity in the implemented filters. Moreover, such a formulation also allows for FIR filter design as every a_k can be equal to 0.

E. Search Space Reduction

1) *Linearized Specifications Projections*: The bounds for a_k and b_k computed in the previous section allow implementing an ILP model by fixing an FxP format and linearizing the bilinear terms involved in the frequency specifications. This first incomplete ILP model does not include the geometry of the adder graph that represents the multiplierless solution as defined in Section II-D. Yet, in order to speed up the solving of the complete ILP model, we tighten the bounds on the coefficients by solving these incomplete ILPs that are simpler than the complete ILP model in the sense that it does not include the geometry of the adder graph defined in Section II-D: they consist in minimizing or maximizing b'_k subject to the stability constraints and the linearized frequency constraints. These ILPs are obviously more difficult to solve than the continuous convex quadratic problems used in the previous section to obtain crude bounds, but still much easier to solve than the final complete model. As it has been shown in [21] in the context of the design of FIR filters, solving these simpler ILPs to obtain tighter bounds for the solving of the final ILP is worthwhile.

2) *Symmetry Breaking*: The model contains some symmetries that can be broken in order to reduce the search space: the first symmetry consists in simultaneously changing the sign of the values taken by b_0 , b_1 and b_2 , the second symmetry consists in exchanging the values taken by b_0 and b_2 . These two symmetries leave the constraints on the coefficients b_k unchanged, as can be easily seen on the explicit expression

$$b_0^2 + b_1^2 + b_2^2 + 2b_0b_1 \cos(\omega) + 2b_1b_2 \cos(\omega) + 2b_0b_2 \cos(2\omega), \quad (17)$$

of (6) involved in the constraint (15): indeed, (17) is insensitive to changing all coefficients sign simultaneously and to exchanging variables b_0 and b_2 . Both symmetries have no incidence on the MCM problem defined in Section II-D, the existence of symmetric adder graphs being obvious for opposed or exchanged coefficients.

As a consequence, from an arbitrary solution with

$$b_0 = b_0^*, b_1 = b_1^* \text{ and } b_2 = b_2^*, \quad (18)$$

we can build three new solutions by simply applying these symmetries to obtain

$$b_0 = -b_0^*, b_1 = -b_1^* \text{ and } b_2 = -b_2^*, \quad (19)$$

$$b_0 = b_2^*, b_1 = b_1^* \text{ and } b_2 = b_0^*, \quad (20)$$

$$b_0 = -b_2^*, b_1 = -b_1^* \text{ and } b_2 = -b_0^*. \quad (21)$$

The fourth solution (21) is obtained by applying the two symmetries consecutively, in any order. Note that some of these four symmetric solutions (18)-(21) may be equal in some special cases, *e. g.*, when $b_0 = b_1 = b_2 = 0$.

Breaking these symmetries means finding additional constraints, called symmetry breaking constraints (SBCs), that remove some symmetric solutions but keep at least one of them [31]. If necessary, symmetric solutions that have not been calculated due to the SBCs can be built afterward. In the best case, SBCs keep only one solution among all symmetric solutions, in that case the SBCs are called total. Therefore, we expect here to reduce the size of the search space by a ratio of four since solutions come within symmetry classes containing four symmetric solutions. Finding SBCs for general symmetry groups is difficult, *e. g.*, SBC generation for symmetries consisting only of variable permutations rely on modern group theoretic algorithms [32]. In our case, the symmetry group is generated by one variable permutation and one central symmetry. Up to our knowledge, SBCs involving both variable permutations and central symmetries have not yet been investigated and no SBC defined for them.

In order to derive these SBCs, the search space for b_0 , b_1 and b_2 , which is \mathbb{R}^3 , is divided into four areas:

$$\Sigma_1 = \{(b_0, b_1, b_2) \in \mathbb{R}^3 \mid b_0 \geq |b_2|\}, \quad (22)$$

$$\Sigma_2 = \{(b_0, b_1, b_2) \in \mathbb{R}^3 \mid -b_0 \geq |b_2|\}, \quad (23)$$

$$\Sigma_3 = \{(b_0, b_1, b_2) \in \mathbb{R}^3 \mid b_2 \geq |b_0|\}, \quad (24)$$

$$\Sigma_4 = \{(b_0, b_1, b_2) \in \mathbb{R}^3 \mid -b_2 \geq |b_0|\}. \quad (25)$$

Then, one can verify that: a solution lying inside Σ_2 moves to Σ_1 applying the sign symmetry; a solution lying inside Σ_3 moves to Σ_1 applying the exchange symmetry; a solution lying inside Σ_4 moves to Σ_1 applying both symmetries consecutively. As a consequence, one can restrict the search to Σ_1 and reconstruct all solutions using symmetries. This restriction to Σ_1 is achieved by adding the SBC

$$b_0 \geq |b_2| \quad (26)$$

to the model. Restricting to another Σ_i would lead to another SBC, with an equivalent improvement of the resolution process.

For completeness, it should be noted that on the frontier $\Sigma_k \cap \Sigma_l$ between areas, two equivalent solutions might still be kept despite the SBC. However, resolving this issue is counter-productive, because the great majority of the search space lies in the interior of the sets Σ_i , and removing the symmetries on the boundaries would introduce many additional constraints.

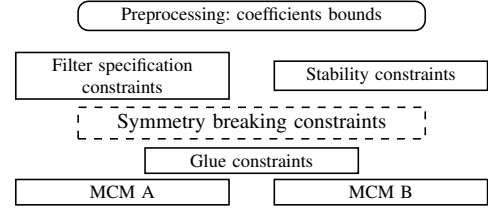

Fig. 3: High-level structure of the global ILP model IIRoptim.

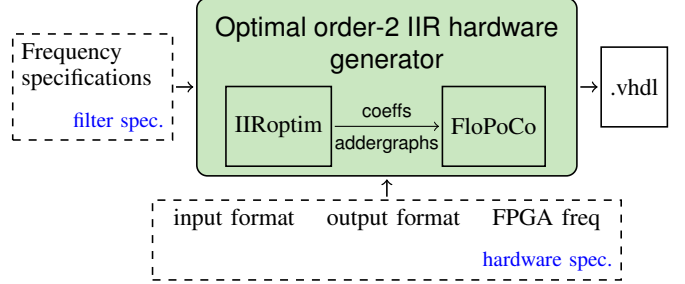

Fig. 4: Interface of the proposed tool.

F. Wrapping Up

To wrap it up, our approach is to model both the filter design and the design of a constant multiplication scheme through shift-and-add using a global ILP problem. On top of that, we search for coefficients directly as integers, *i. e.*, in a FxP format with user-given word length. Since filter coefficients, depending on the filter specification and word length, can have different MSB positions, we first perform a pre-processing. This pre-processing consists in solving a quadratic convex optimization problem yielding tight and rigorous bounds on filter coefficients and permitting to define coherent MSB positions and construct the design space for the main model. As Fig. 3 shows, the high-level IIR model consists of the following constraints:

- linearized frequency-specification constraints (6)-(8) ;
- stability constraints (13)-(14);
- (optional) symmetry breaking constraints (26) enabling a significant reduction of the design space;
- constraints responsible for the design of optimal constant-multiplication blocks for a_k and b_k using [10] or [11];
- so-called glue constraints, connecting the unknown filter coefficients with multiplier blocks analogously to [21].

The above ILP model can now be solved using any available ILP solver. Moreover, despite its non-linearity, the pre-processing problem can be solved using most generic ILP solvers as well, thanks to its convexity.

III. EXPERIMENTAL RESULTS AND DISCUSSION

A. Implemented Toolflow

We implemented our approach into a tool, whose minimalist interface is shown in Fig. 4. The input specification includes the frequency-domain specification of the filter, and also the information for hardware implementation, *i. e.*, the coefficient word length, the input/output formats and performance parameters, such as the required frequency for target technology

TABLE I: Sets of lowpass filters used for the IIR experiments. First the set with decreasing δ , next the sets with increasing passband and stopband. Finally, a lowpass filter.

Benchmarks	lp1 _k	lp2 _k	lp3 _k	lp4
k	{0, 1, ..., 6}	{0, 1, ..., 4}	{0, 1, ..., 4}	–
passband/ π	[0; 0.3]	[0; 0.3 + 0.05k]	[0; 0.3]	[0; 0.5]
stopband/ π	[0.7; 1]	[0.7; 1]	[0.7 – 0.05k; 1]	0.91
δ	0.1 – 0.01k	0.1	0.1	0.1

(currently different FPGA targets). All the other parameters (filter coefficients and their FxP format, the multiplierless operator architecture, the representation of intermediate data, etc.) are determined automatically as a part of a global optimization process. One of the goals of our tool is to bring the attention of the filter designer to the higher-level parameters, *e.g.*, filter specifications, while relying on our optimal implementations.

Our new ILP model and the front-end of the proposed tool are implemented in `julia` language, which offers a unified access to the major ILP solvers through the `JuMP` library. Given the user input, we first construct an ILP model and solve it with one of many open-access or commercial solvers available through `JuMP`, such as Gurobi, CPLEX, GLPK, etc. The result of the global optimization problem, *i.e.*, the list of filter coefficients and the adder graphs defining the optimal shift-and-add architectures, is then passed on to the FloPoCo² hardware code generator [33]. FloPoCo is the state-of-the-art tool for the design and automatic generation of fixed/floating-point arithmetic cores. We implemented a new operator `FixIIRShiftAdd`, generating faithfully-rounded multiplierless IIR filters, *i.e.*, only the last output bit might be erroneous and all other bits are guaranteed to be correct. The new operator alleviates the filter designer from all internal architectural decisions and presents a final VHDL code.

The tool and all benchmarks, are freely available^{2,3} and reproducible.

B. Set of Benchmarks and Comparison Approaches

Benchmarks: Although the design of second-order IIR filters is an important part of the design of larger order filters, benchmarks are rarely targeting frequency specifications of individual second-order sections. Hence, we use three sets of filter specifications with increasing filter design difficulty that could without doubt be used in real-life applications. In addition to that, we add another artificial low-pass filter, and a real-life example from [15].

The normalized low-pass filter specifications are here defined as

$$\begin{aligned}
 1 - \delta &\leq |H(e^{i\omega})| \leq 1 + \delta, & \forall \omega \in [0; \omega_p], & \text{(passband)} \\
 0 &\leq |H(e^{i\omega})| \leq \delta, & \forall \omega \in [\omega_s; 1]. & \text{(stopband)}
 \end{aligned}$$

We fix the initial passband to [0; 0.3], stopband to [0.7; 1] and $\delta = 0.1$. Then, for each of the families of filter specifications, we vary one of the parameters in dependence of a variable k

²<http://flopoco.org/>

³<https://gitlab.univ-nantes.fr/volkova-a/jiir2hw>

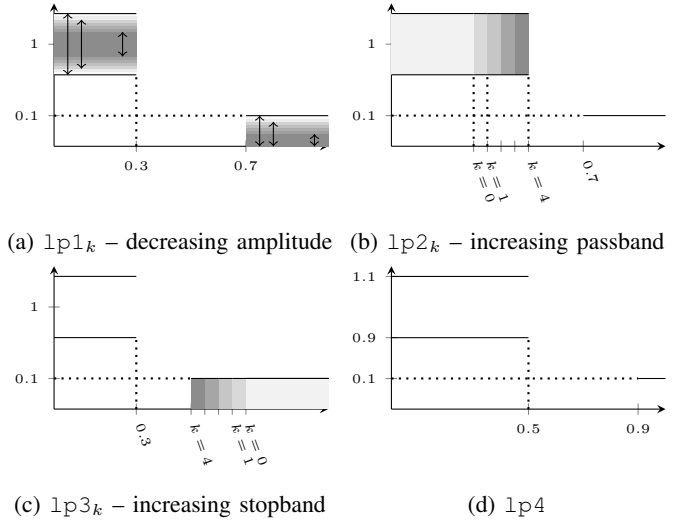

Fig. 5: Proposed families of benchmarks.

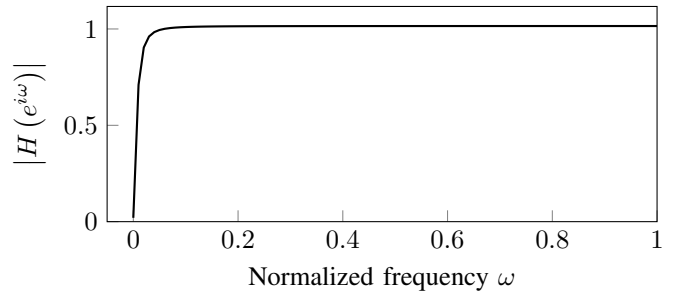

Fig. 6: Frequency response of the compensator hp0 [35], [36].

to increase the filter design difficulty. The detailed frequency specifications for each family of filters are given in Table I, and their graphical representation is sketched in Fig. 5. For example, in family lp1, the δ varies from 0.1 to 0.04 with step $0.01k$ where $k = 0, \dots, 6$. However, the designs were possible only up to $k = 5$, reaching the maximum design possibilities for second-order IIR filters. Analogously, the families lp2 and lp3 increase/reduce the pass/stopband, respectively. The filter specification lp4 is a lowpass with a short stopband.

Finally, our last benchmark hp0 is a highpass filter (Fig. 6), which is a compensator used in a magnetic-bearing control system and was derived by discretizing the analog controller [34], [35]. The recent result [15] uses this filter to demonstrate a KCM-based faithfully-rounded implementation of IIR filters, hence permits a direct comparison. Even though this filter is not defined in terms of frequency specifications but by its frequency response (sole poles and zeroes are given in literature), the versatility of an ILP modeling permits to easily integrate frequency response bounds as functions of ω and not simply constants.

Comparison approaches: We aim at comparing with the classical and state-of-the-art approaches for the IIR design comparing high level metrics like adder counts and implementation results for FPGAs. The classical approach passes through three steps

- 1) **FD:** in our case double-precision filter coefficients are

obtained, if possible, with Matlab’s elliptic method;

2) **Q**: as in Matlab’s Fixed-Point design Toolbox, we convert the double coefficients to FxP with the user-specified word length and round-to-nearest mode. Post-design quantization often leads to errors in frequency response or instabilities, hence we increase the word length s. t. the frequency-domain error is below a threshold ($< 10^{-7}$) and the filter is stable;

3) **I**: generic multipliers provided by hardware manufacturers are often used. By default, the digital signal processing (DSP) blocks (whose availability and number on each FPGA board vary), are allowed but it might be interesting to disable them to provide comparison with purely LUT-based implementations. We also compare with the state-of-the-art constant multiplications based on KCM [15] and MCM [11] methods.

Different combinations of the above steps are possible. Each of the benchmark filter specifications will be implemented using the following approaches:

- 3-step Generic: Matlab’s FD + Q + implementation using generic FPGA multipliers (using the VHDL ‘*’ operator, potentially using DSP blocks);
- 3-step Generic NoDSP: same as above with disabled DSP blocks for synthesis and implementation;
- 3-step MCM: Matlab’s FD + Q + optimal shift-and-add implementation for FxP coefficients;
- 2-step KCM: Matlab’s FD + approach from [15], which directly obtains a KCM-based implementation for real coefficients;
- Ours: 1-step combined approach, performing directly FD & Q & I using optimal shift-and-add multipliers.

The 3-step Generic (NoDSP) can be seen as a baseline while 3-step MCM and 2-step KCM is the state-of-the-art. With such a setting, our goal is to analyze the benefits of the global approach compared to 2- or 3-step approaches that first fix filter coefficients to some values and only then optimize for implementation.

Bit widths: The coefficient word length is an input parameter for our tool, hence, for each specification we will explore a range of different coefficient word lengths. For the input/output data in hardware implementation, we used 8-, 12- and 16-bit configurations but, due to the lack of space, only the results for 16-bit experiments are reported in the paper. See the tool’s git repository for full benchmark information.

C. Evaluation of the ILP Model and Design Results

In the following we evaluate the performance of our ILP model, explore the design space and compare with the 3-step MCM-based approach to see the benefits w. r. t. number of adders in a shift-and-add implementation. All experiments were performed on a Linux laptop with i7-10810U processor and 32 GB RAM. Any generic solver with an interface for JuMP library [37] can be used, here we used CPLEX 12.10 [38].

The first remark concerning our tool is that the running times are quite reasonable, varying from 10 seconds for small word lengths (4-5 bits) and going up to a few minutes for the largest word length we can deal with, which is roughly 10 bits. By default, we use the symmetry breaking constraints

TABLE II: Results for our global optimization method vs. applying optimal MCM upon quantized coefficients. The total number of adders A ($A = A_M + A_S$) consists in the multiplier block A_M , and structural A_S adders. Results are reported for the smallest coefficient word length W possible.

Benchmark	Our method				3-step MCM			
	W	A_M	A_S	A	W	A_M	A_S	A
lp1 ₀	4	1	4	5	10	8	4	12
lp1 ₁	4	1	4	5	16	11	4	15*
lp1 ₂	4	2	4	6	6	5	4	9
lp1 ₃	4	3	4	7	10	7	4	11
lp1 ₄	5	4	4	8	9	7	4	11
lp1 ₅	5	4	4	8	—	—	—	—
lp2 ₀	4	1	4	5	10	8	4	12
lp2 ₁	4	1	4	5	10	8	4	12
lp2 ₂	5	3	4	7	10	8	4	12
lp2 ₃	6	4	4	8	—	—	—	—
lp3 ₀	4	1	4	5	10	8	4	12
lp3 ₁	4	2	4	6	4	2	4	6
lp3 ₂	4	3	4	7	23	18	4	22*
lp3 ₃	5	3	4	7	—	—	—	—
lp4	4	1	4	5	4	3	4	7
hp0	6	1	2	3	11	6	4	10

* heuristic solution using [7]

as in general we observed a significant improvement (around $2\times-20\times$) in running times, depending on problem complexity. Obviously, the complexity of the ILP model is increasing with increasing the word length, since the ranges of integer variables are doubled with each new coefficient bit, and a few additional variables and constraints are added as well. However, it is not the model complexity but numerical instabilities that represent the main bottleneck in pushing the coefficient word lengths further than 10-11 bits. Indeed, our ILP model for the MCM design makes intensive use of the so-called big-M constraints, that are limited by certain floating-point tolerances internal to the solver, beyond which the solver cannot use efficient floating-point arithmetic for integer programming. An alternative to the big-M are the indicator constraints but the drawback is the increased computational time, leading to a similar bound on the maximum coefficient word lengths.

The second remark is that with our tool, an infeasibility of the design problem can be quickly proven. For example, for the specification lp1₄ in just a few seconds we prove that no implementation that perfectly fits the specification with word length 4 is possible. This is an important feature, since when trying to lower the coefficient word length as much as possible, the filter designer can quickly stop the exploration. Inversely, when searching the smallest feasible word length, the design iteration will quickly move on from infeasible ones.

The goal of our tool is to provide optimal architectures w. r. t. the number of adders in the multiplierless implementation. The number of adders is not a fine-grained metric but it enables the design-space exploration a priori, before any hardware synthesis and experiments. It is a good indicator of the performance of implemented systems, as the number of adders is correlated with the number of LUTs.

We claim that optimizing the filter coefficients simultane-

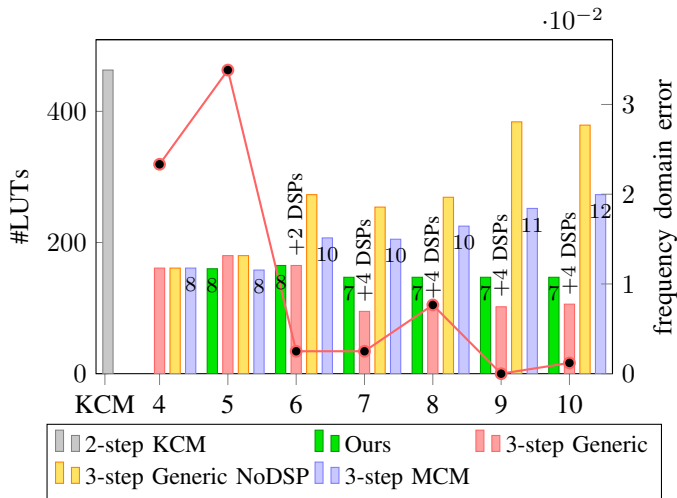

Fig. 7: Implementations for $1p_{14}$ benchmark with coefficient word lengths varying from 4 to 10 bits. The bars correspond to the number of LUTs (left axis) and labels on bars denote number of adders. The frequency-domain error of 3-step methods is the red line (right axis).

ously for the filter design and MCM problem yields smaller total number of adders than the 3-step MCM approach, as it covers the whole design space. Table II presents the optimization results for our method, and for the 3-step MCM method. We report results for the smallest word lengths possible, in which our method has a feasible result (and, by construction, no frequency domain error) and the Q step in 3-step MCM yields stable filters with frequency-domain error smaller than 10^{-7} .

It can be noticed that our method finds solutions for smaller coefficient word lengths than the 3-step MCM, and with significant smaller total number of adders for most of the cases ($\approx 46\%$ on average in Table II). In some cases, marked with asterisk, target word lengths for 3-step MCM were too big s. t. the optimal MCM timed-out and the RPAG heuristic [7] was used to obtain adder graphs instead. For the specification $1p_4$ both approaches find designs with 4-bit coefficients, but thanks to efficiently covering the whole design space of all possible FxP coefficients, our method determines coefficients that require fewer adders in the multiplier block and the total of 5 adders, instead of 7. Finally, the benchmark $1p_{31}$ is the only case when the coefficients in 3-step MCM coincide with the ones found by our tool.

Another advantage of the proposed ILP formulation is privileging sparse implementations, which even for second-order filters largely improves performance due to smaller number of structural adders. For instance, the benchmark hp_0 was traditionally implemented with all non-zero coefficients [15], [35]. We have approximated the frequency response of this compensator using the poles and zeros from the original paper [34] and used it as reference in our ILP. As a result, a sparse implementation with 6-bit coefficients was possible, having as coefficients $b_0 = 1$, $b_1 = -1$, $b_2 = 0$, $a_1 = -31/32$, $a_2 = 0$ and leading to the total of 3 adders for the whole filter. To compare, the 3-step MCM can provide at minimum 11-bit

coefficients implemented with 10 adders. Moreover, our design has poles further apart from the unit circle, which improves the numerical quality of the time-domain implementation.

Our tool provides results for difficult specifications even when FD with Matlab fails. For benchmarks $1p_{15}$, $1p_{23}$ and $1p_{33}$ no IIR filter design method in Matlab could find double-precision coefficients for a frequency response of sufficient quality. Our method, however, successfully completes the task.

It is important to note that our tool provides optimal implementations w.r.t. the total number of adders for a given coefficient word length. In other words, finding the best coefficient word length is still the filter designer task. While typical flow is to stop at the smallest possible coefficient word length, as in Table II, it does not necessarily lead to the optimal implementation w.r.t. all possible word lengths, and increasing the coefficient word length can actually lead to fewer adders.

To illustrate this, Fig. 7 shows synthesis results for the $1p_{14}$ benchmark with coefficient word lengths varying from 4 to 10 bits (the hardware implementation is described in details in Section III-D). It can be seen that increasing the word length from 5 bits to 7 bits actually reduces the total number of adders from 8 to 7 and improves the result implementation. Moreover, our approach provides a stable behavior: once a 7-adder solution is found, increasing coefficient word length will never lead to a worse implementation. In practice, the ILP either finds different coefficients with the same number of adders, or simply multiplies values by two for each additional bit (which is the case in Fig. 7 starting 7 bits). In other words, even if the user specifies a larger word length than required, our tool finds the best coefficients that might fit in a smaller format and guarantees that trying smaller word length will not give smaller number of adders.

For the classical 3-step approaches, design-space exploration is more difficult and irregular. For these methods, coefficient quantization introduces a frequency-domain error meaning that the quantized filter does not satisfy the frequency specifications any more (see the red line in Fig. 7). This error is highly non-linear, and a typical intuition that increasing coefficient word length improves the quality of filter is simply not true (see the frequency-domain error for 7- and 8-bit coefficients in Fig. 7). Hence, the search for the best coefficient size must be exhaustive for 3-step methods.

D. Hardware Implementation and Discussion

In the following, we first describe in details the faithfully-rounded architectures that we implement in FloPoCo and then discuss the synthesis results obtained for our benchmarks and each approach.

Implemented architecture: We aim at providing faithfully-rounded implementations, *i.e.*, the precision of the output y (the Least Significant Bit (LSB) position ℓ_{out}) serves as the accuracy constraint. There are different ways to assign the sizes of data paths for a filter implementation, and it is important to not underestimate the sizes (otherwise overflow occurs) but, on the other hand, assigning larger data sizes will waste resources to compute unnecessary bits.

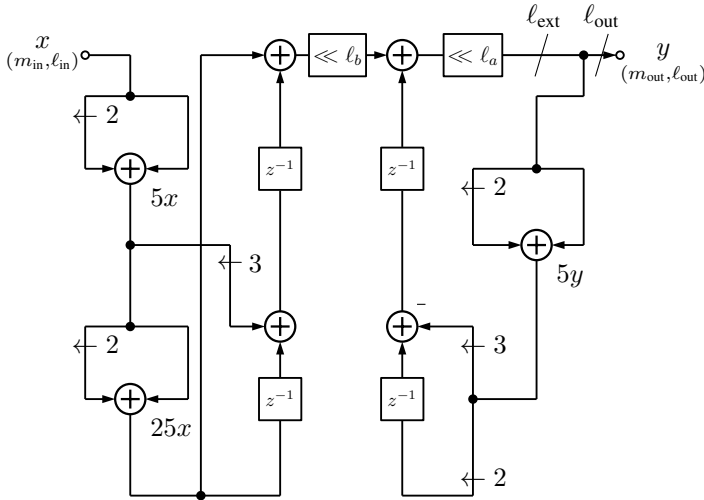

Fig. 8: The $1p_{14}$ benchmark can be implemented with mere 7 adders. All additions are exact, the truncation to internal extended format ℓ_{ext} is determined using the WCPG s.t. the output is faithfully rounded to ℓ_{out} .

Hence, our goal is to provide a code generator that, given the input/output format and filter coefficients, automatically computes the word sizes of all internal data paths to guarantee the time-domain error smaller than $2^{\ell_{\text{out}}}$ but not more.

Fig. 8 presents our approach for multiplierless hardware IIR on the example of $1p_{14}$ benchmark, which can be implemented with 7 adders. Its transfer function was obtained as

$$H_{1p_{14}}(z) = \frac{25 \times 2^{-7} + 40 \times 2^{-7} z^{-1} + 25 \times 2^{-7} z^{-2}}{1 - 40 \times 2^{-6} z^{-1} + 20 \times 2^{-6} z^{-2}}. \quad (27)$$

The inputs to the architecture generator are the MSB and LSB positions of the input x and output y , the adder graphs for multiplier blocks a_k and b_k , and their corresponding LSBs. For instance, here $\ell_b = -7$, $\ell_a = -6$.

Obviously, one cannot compute exactly (or with some fixed precision) on each iteration, truncate to ℓ_{out} and simply feed truncated values back into the loop, as this will degrade tremendously numerical quality and accumulated errors will explode. The Worst-Case Peak Gain (WCPG) measure for IIR filters [39], which has been applied for hardware IIR filters implemented with KCM multipliers [15], permits to determine the necessary extended internal precision ℓ_{ext} s.t. the propagated error never reaches the LSB of the output. For example, in Fig. 8 $\ell_{\text{ext}} = \ell_{\text{out}} + G$, where the number of guard bits G for the filter $1p_{14}$ determined with its WCPG is $G = 3$. Then, the output of the multiplier blocks needs to guarantee its result with accuracy ℓ_{ext} . In our architecture we perform all additions and shifts exactly, increasing the size of data paths until their truncation to ℓ_{ext} .

For the generic approach, based on plain VHDL multipliers (using the $*$ operator), we adopt a similar approach.

Synthesis results: Synthesis was performed using Vivado v2019.1 for a Kintex 7 device (xc7k70tfbv484-3). The delay is reported after place and route. We performed the experiments for 8-, 12- and 16-bit inputs/outputs considering the inputs

to have the MSB position -1 . For conciseness, we report the results only for the 16-bit experiments but the same observations hold for 8- and 12-bit ones.

To leave the process of (non-optimal) search for the best coefficient size out of scope, we further compare the designs with the smallest coefficient word lengths, for which our ILP has a feasible solution, and the 3-step approach has a frequency-domain error smaller than 10^{-7} . Fig. 9 summarizes the obtained resources (LUTs and DSPs) and the critical path delay. For each benchmark, on x-axis we see the coefficient word length for our result (left) and for the 3-step quantization (right). For instance, we recognize the values 5 and 9 for the $1p_{14}$.

We can observe that our method is always superior to any of the classical or state-of-the-art methods, both in terms of LUTs and delay. On our benchmarks we observed the average LUT improvement of 42% compared to the best results of other methods. In addition to that, the proposed approach offers the lowest delay with an improvement of 21%, which is not as drastic as LUT improvement but expected due to the similar number of delays. Of course, our method is more efficient partly due to the smallest possible coefficient word lengths, but even when using the same word sizes (see benchmark $1p_4$) our design requires less LUTs and has smaller delay.

The KCM-based approach, representing the state-of-the-art approach for faithfully-rounded IIR filters, had worse general performance than our method in all benchmarks. While the LUT consumption of KCM-based IIR filters is significantly bigger than for our approach, it is comparable to the 3-step Generic NoDSP approach. However, in terms of delay, KCM-based multipliers prove to be generally faster or comparable to 3-step methods. It should be noted that the superiority of our approach over KCM-based IIR filters is not a surprise for the small word lengths, according to the recent result [14], and while it can be expected that our approach is possible only for word lengths less than 16 bits due to optimization time-out, the KCM-based multipliers will have no issue dealing with large word lengths.

It can be noted that with the increase in frequency specification difficulty, the 3-step methods generally degrade in performance, while our design methods have a more regular behavior, providing small and fast implementations even for complicated filters.

One of the best performance improvements was achieved for the hp_0 compensator. This is due to the much smaller coefficient word length than in all the previous literature, the sparsity and the fact that we succeeded in finding a filter with poles further from the unit circle. As a consequence, the number of internal guard bits was smaller too, resulting in only 105 LUTs compared to 286 in the 3-step MCM and 760 in the KCM-based filters.

IV. CONCLUSION AND PERSPECTIVES

We proposed a new method called `IIRoptim` for the optimal design of multiplierless second-order IIR filters w.r.t. the number of adders. Our approach is based on a combined global optimization problem, which searches for stable filter

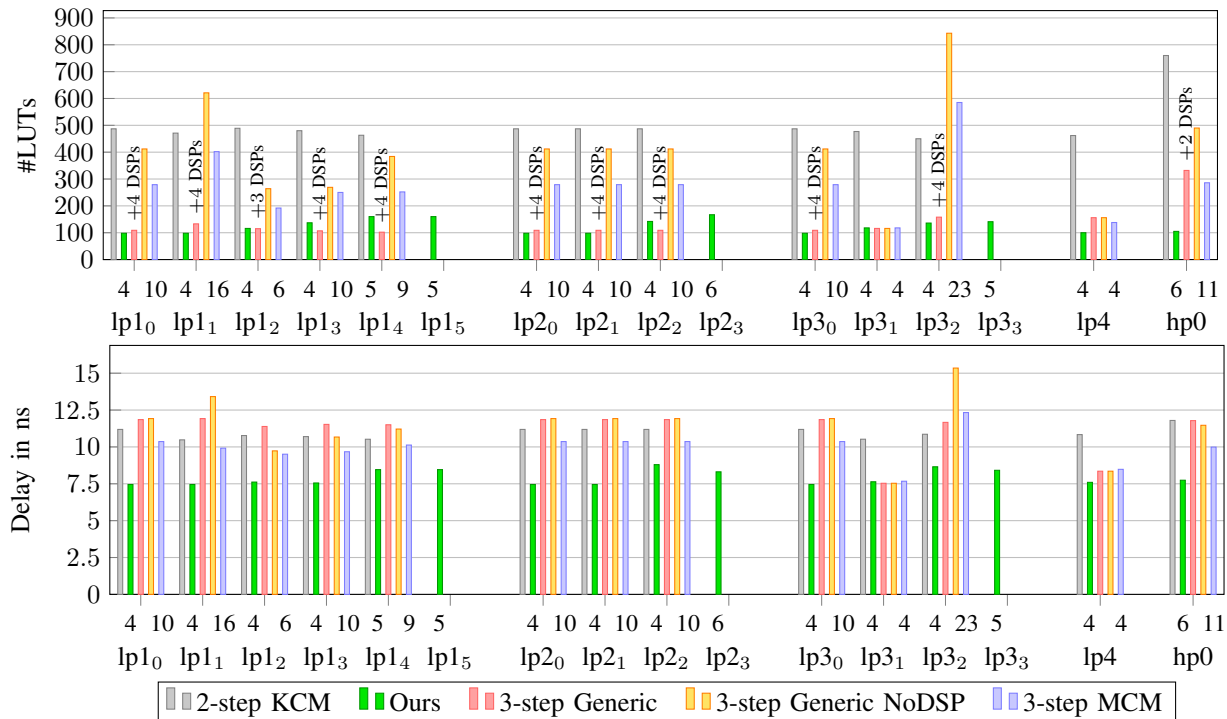

Fig. 9: Benchmark results of resources (LUTs + DSPs) and critical path delay for the I/O word length 16 bits.

coefficients in FxP format such that the number of adders in a shift-and-add implementation is minimized. Furthermore, we proposed an automated tool which combines `IIRoptim` with `FloPoCo` and provides automatic hardware code generation for implementation on FPGA. With our tool, the instabilities and quantization effects on second-order IIR filters become a thing of the past.

We proposed a linearized formulation of the combined filter design and MCM problem as one ILP model, which provides a convenient way for extensions. Several design space reduction techniques were proposed, including a novel symmetry breaking constraint, which we formally proved. As a result, the filter design and optimization takes mere seconds.

Our approach has several useful and important consequences. First, with our ILP it is easy and quick to prove the impossibility of a design, with a given coefficient word length and large enough range of MSBs, such that the filter specifications are *fully* satisfied. Moreover, this would be true for any smaller coefficient word length, providing a filter designer the unprecedented assurance that the design space exploration in that direction can be stopped. Second, if the filter design is possible with a certain given word length, increasing the word length will never yield a larger number of adders, and often the coefficients will remain the same or shifted by one bit. With this property and the fact that all our designs are guaranteed to have zero frequency-domain error, typical non-linearities in the second-order IIR design process are no longer an issue, making the design-space exploration a more regular process.

For hardware experiments, we provided a faithfully-rounded multiplierless operator for IIR filters within `FloPoCo`. The synthesis results confirmed that a global optimization approach

is superior to the multi-step FD & Q & I classical methods, and even to the state-of-the-art KCM-based IIR filters. With the ILP formulation we search directly the FxP coefficient design space, privileging sparse implementations and sometimes finding the filters that even double-precision Matlab fails to find. After testing the tool on numerous benchmarks, we observed a 42% improvement in number of LUTs, and 21% improvement in delay, on average.

The superiority over the KCM-based IIR [15], that were first to introduce faithfully-rounded filters using analysis of the worst-case rounding errors, advances the progress towards reliable IIR filters and demonstrates again that numerical guarantees do not necessarily come at a higher cost.

Some efforts are still required to extend our method, in particular to higher order filters. We see two possible directions for that extension, first, a single ILP model which would permit the design of cascaded second order sections and, second, an external loop for the decomposition of specifications into simpler specifications that are reachable by a second order filter. Extension to other structures than the Direct Forms is also a promising direction that should be tackled in the future.

Although the number of adders is a reliable high level metric, optimizing the number full adders instead would be better. We are fairly optimistic on the fact that our method can be refined to minimize that criteria, first as a post-design optimization of truncations, and then as one global optimization problem. Furthermore, we plan to introduce the truncations of data paths and model the rounding-error in the ILP model. This will permit further performance gains in the implemented filters.

REFERENCES

- [1] Z. Smékal and R. Vích, “Optimized models of IIR digital filters for fixed-point digital signal processor,” in *ICECS ’99. Proceedings of ICECS ’99. 6th IEEE International Conference on Electronics, Circuits and Systems*, vol. 1, Sep. 1999, pp. 145–148.
- [2] G. Vanuytsel, P. Boets, L. Van Biesen, and S. Temmerman, “Efficient hybrid optimization of fixed-point cascaded IIR filter coefficients,” in *IMTC/2002. Proceedings of the 19th IEEE Instrumentation and Measurement Technology Conference*, vol. 1, May 2002, pp. 793–797.
- [3] Y. Wang, B. Li, and Z. Li, “Fixed-point digital IIR filter design using multi-objective optimization evolutionary algorithm,” in *2010 IEEE Youth Conference on Information, Computing and Telecommunications*, Nov. 2010, pp. 174–177.
- [4] M. Gevers and G. Li, *Parametrizations in Control, Estimation and Filtering Problems: Accuracy Aspects*, 01 1993.
- [5] A. Dempster and M. Macleod, “Use of Minimum-Adder Multiplier Blocks in FIR Digital Filters,” *IEEE Transactions on Circuits and Systems II: Analog and Digital Signal Processing*, vol. 42, no. 9, pp. 569–577, 1995.
- [6] Y. Voronenko and M. Püschel, “Multiplierless Multiple Constant Multiplication,” *ACM Transactions on Algorithms*, vol. 3, no. 2, pp. 1–38, 2007.
- [7] M. Kumm, P. Zipf, M. Faust, and C.-H. Chang, “Pipelined adder graph optimization for high speed multiple constant multiplication,” in *2012 IEEE International Symposium on Circuits and Systems*, May 2012.
- [8] L. Aksoy, E. da Costa, P. Flores, and J. Monteiro, “Exact and Approximate Algorithms for the Optimization of Area and Delay in Multiple Constant Multiplications,” *IEEE Transactions on Computer-Aided Design of Integrated Circuits and Systems*, vol. 27, no. 6, pp. 1013–1026, 2008.
- [9] M. Kumm, D. Fanghänel, K. Möller, P. Zipf, and U. Meyer-Baese, “FIR Filter Optimization for Video Processing on FPGAs,” *Springer EURASIP Journal on Advances in Signal Processing*, pp. 1–18, 2013.
- [10] M. Kumm, *Multiple Constant Multiplication Optimizations for Field Programmable Gate Arrays*. Springer Fachmedien Wiesbaden, 2016.
- [11] —, “Optimal Constant Multiplication Using Integer Linear Programming,” *IEEE Transactions on Circuits and Systems II: Express Briefs*, vol. 65, no. 5, pp. 567–571, 2018.
- [12] K. D. Chapman, “Fast Integer Multipliers Fit in FPGAs,” *Electronic Design News*, 1994.
- [13] M. Faust and C.-H. Chang, “Bit-parallel Multiple Constant Multiplication using Look-Up Tables on FPGA,” *IEEE International Symposium of Circuits and Systems (ISCAS)*, pp. 657–660, 2011.
- [14] F. d. Dinechin, S.-I. Filip, L. Forget, and M. Kumm, “Table-Based versus Shift-And-Add Constant Multipliers for FPGAs,” in *IEEE Symposium on Computer Arithmetic (ARITH)*, 2019.
- [15] A. Volkova, M. Istoan, F. De Dinechin, and T. Hilaire, “Towards Hardware IIR Filters Computing Just Right: Direct Form I Case Study,” *IEEE Transactions on Computers*, vol. 68, no. 4, pp. 597–608, 2019.
- [16] A. V. Oppenheim and R. W. Schaffer, *Discrete-Time Signal Processing*, 3rd ed. USA: Prentice Hall Press, 2009.
- [17] H. Leich, “Toolbox for the design of IIR digital filters,” in *Proceedings of 13th International Conference on Digital Signal Processing*, vol. 2, Jul. 1997, pp. 621–624.
- [18] W. K. Jenkins and M. Nayeri, “Adaptive filters realized with second order sections,” in *ICASSP ’86. IEEE International Conference on Acoustics, Speech, and Signal Processing*. Institute of Electrical and Electronics Engineers, 1986.
- [19] A. G. Dempster and M. D. Macleod, “Comparison of IIR filter structure complexities using multiplier blocks,” in *Proceedings of ISCAS’95 - International Symposium on Circuits and Systems*, vol. 2, Apr. 1995, pp. 858–861.
- [20] S. Ansari, G. Kishor, P. K. Verma, N. Agrawal, I. Sharma, and A. Kumar, “Design of multiplierless digital iir filter using modified cuckoo search algorithm,” in *2018 International Conference on Communication and Signal Processing (ICCCSP)*, 2018, pp. 0405–0410.
- [21] M. Kumm, A. Volkova, and S.-I. Filip, “Design of Optimal Multiplierless FIR Filters with Minimal Number of Adders,” May 2021, working paper or preprint. [Online]. Available: <https://hal.archives-ouvertes.fr/hal-02392522>
- [22] R. Hettich and K. O. Kortanek, “Semi-infinite programming: Theory, methods, and applications,” *SIAM Review*, vol. 35, no. 3, pp. 380–429, 1993.
- [23] A. Volkova, C. Lauter, and T. Hilaire, “Reliable Verification of Digital Implemented Filters Against Frequency Specifications,” in *2017 IEEE 24th Symposium on Computer Arithmetic (ARITH)*. IEEE, Jul. 2017.
- [24] A. Marendet, A. Goldsztejn, G. Chabert, and C. Jermann, “A standard branch-and-bound approach for nonlinear semi-infinite problems,” *EJOR*, vol. 282, no. 2, pp. 438–452, 2020.
- [25] A. Billionnet, S. Elloumi, and A. Lambert, “Linear Reformulations of Integer Quadratic Programs,” in *Modelling, Computation and Optimization in Information Systems and Management Sciences*. Berlin, Heidelberg: Springer Berlin Heidelberg, 2008, pp. 43–51.
- [26] F. Glover, “Improved Linear Integer Programming Formulations of Nonlinear Integer Problems,” *Management Science*, vol. 22, no. 4, pp. 455–460, Dec. 1975.
- [27] M. Oral and O. Kettani, “A Linearization Procedure for Quadratic and Cubic Mixed-Integer Problems,” *Operations Research*, vol. 40, no. 1-supplement-1, pp. S109–S116, Feb. 1992.
- [28] D. Bertsimas and J. Tsitsiklis, *Introduction to linear optimization*. Belmont, Mass: Athena Scientific, 1997.
- [29] O. L. Mangasarian, “Absolute value programming,” *Computational Optimization and Applications*, vol. 36, no. 1, pp. 43–53, Nov. 2006.
- [30] A. Antoniou, *Digital Filters: Analysis, Design, and Signal Processing Applications*. New York: McGraw-Hill Education, 2018.
- [31] T. Walsh, “General Symmetry Breaking Constraints,” in *Principles and Practice of Constraint Programming - CP 2006*. Springer Berlin Heidelberg, 2006, pp. 650–664.
- [32] A. Goldsztejn, C. Jermann, V. Ruiz de Angulo, and C. Torras, “Variable symmetry breaking in numerical constraint problems,” *Artificial Intelligence*, vol. 229, pp. 105–125, 2015.
- [33] F. de Dinechin and B. Pasca, “Designing Custom Arithmetic Data Paths with FloPoCo,” *IEEE Design & Test of Computers*, vol. 28, no. 4, pp. 18–27, Jul. 2011.
- [34] F. Krach, B. Frackelton, J. Carletta, and R. Veillette, “FPGA-based implementation of digital control for a magnetic bearing,” in *Proceedings of the 2003 American Control Conference, 2003*. IEEE, 2003.
- [35] O. Sarbishei, K. Radecka, and Z. Zilic, “Analytical Optimization of Bit-Widths in Fixed-Point LTI Systems,” *IEEE Transactions on Computer-Aided Design of Integrated Circuits and Systems*, vol. 31, no. 3, pp. 343–355, Mar. 2012.
- [36] J. Carletta, R. Veillette, F. Krach, and Z. Fang, “Determining appropriate precisions for signals in fixed-point IIR filters,” in *Proceedings 2003. Design Automation Conference*, Jun. 2003, pp. 656–661.
- [37] I. Dunning, J. Huchette, and M. Lubin, “Jump: A modeling language for mathematical optimization,” *SIAM Review*, vol. 59, no. 2, pp. 295–320, 2017.
- [38] CPLEX, “CPLEX User’s Manual,” 2020. [Online]. Available: <https://www.ibm.com/analytics/cplex-optimizer>
- [39] A. Volkova, T. Hilaire, and C. Lauter, “Reliable Evaluation of the Worst-Case Peak Gain Matrix in Multiple Precision,” in *2015 IEEE 22nd Symposium on Computer Arithmetic*. IEEE, Jun. 2015.



Rémi Garcia obtained his Bachelor’s Degree in Mathematics and his Master’s Degree in Computer Science from University of Nantes, France, in 2016 and 2020, respectively. He joined the LS2N, France, in 2020 as a PhD student in Computer Science. His research interests include optimization applied to signal processing and computer arithmetic.



Anastasia Volkova received her Master’s Degree in Applied Mathematics from Odessa National University, Ukraine, in 2014. She obtained a PhD in Computer Science from Sorbonne University in Paris, France in 2017. She was a postdoctoral researcher at Inria, France and an AI research resident at Intel Corporation. In 2019 she joined University of Nantes, France, as an Associate professor. Her research interests include computer arithmetic, validated numerical computing and design of optimized software/hardware for floating-point and

fixed-point algorithms.



Martin Kumm received the Dipl.-Ing. degree in electrical engineering from the University of Applied Sciences Fulda, Germany, and the Technical University of Darmstadt, Germany, in 2003 and 2007, respectively. From 2003 to 2009, he was with GSI Darmstadt, working on digital RF control systems for particle accelerators. In 2015 he received his Ph.D. (Dr.-Ing.) degree from the University of Kassel, Germany. He is currently a Professor for Embedded Systems at the Fulda University of Applied Sciences, Germany. His research interests are

arithmetic circuits and their optimization as well as high-level synthesis, all in the context of reconfigurable systems.



Alexandre Goldsztejn received the Engineer degree in computer science and mathematics from the Institut Supérieur d'Electronique et du Numérique, Lille, France, in 2001, and the Ph.D. degree in computer science from the University of Nice Sophia Antipolis, Nice, France, in 2005. He has spent one year as a Postdoctoral Fellow with the University of Central Arkansas, Conway, AR, USA, and the University of California, Irvine, CA, USA. Since 2007, he has been a full-time CNRS Researcher with the Laboratoire des Sciences du Numérique de

Nantes, Nantes, France. His research interests include interval analysis and its applications to constraint satisfaction, nonlinear global optimization, robotics, and control.



Jonas Kühle received his Bachelor's degree in Applied Computer Science from University of Applied Sciences Fulda in 2017 where he is about to complete his Master's degree in 2021 and will start as a PhD student in 2022.