

A Database for Research on Detection and Enhancement of Speech Transmitted over HF links

Jens Heitkaemper¹, Joerg Schmalenstroer¹, Joerg Ullmann¹, Valentin Ion², Reinhold Haeb-Umbach¹

¹ Department of Communications Engineering, Paderborn University, Germany ² Plath GmbH, Hamburg, Germany
Email: {heitkaemper, schmalen, ullmann, haeb}@nt.uni-paderborn.de

Abstract

In this paper we present an open database for the development of detection and enhancement algorithms of speech transmitted over HF radio channels. It consists of audio samples recorded by various receivers at different locations across Europe, all monitoring the same single-sideband modulated transmission from a base station in Paderborn, Germany. Transmitted and received speech signals are precisely time aligned to offer parallel data for supervised training of deep learning based detection and enhancement algorithms. For the task of speech activity detection two exemplary baseline systems are presented, one based on statistical methods employing a multi-stage Wiener filter with minimum statistics noise floor estimation, and the other relying on a deep learning approach.

1 Introduction

During the last decade deep neural networks (DNNs) have achieved impressive results on a variety of speech tasks, such as speech activity detection (SAD), speech enhancement, source separation, and automatic speech recognition (ASR) [1–3]. Their success, however, rests crucially on the availability of labeled training data, as the systems are trained in a supervised manner [4].

Manual annotation of training data can be a very tedious task, and for some problems, such as speech enhancement, it is nearly impossible for large data sets. This issue can be circumvented with parallel data, which refers to the existence of distorted and clean versions of the same utterance. While the former is applied to the network input, the latter can be used to automatically derive the training targets. For example, targets for time frequency masks can be generated from clean speech and then used to train a mask estimator from noisy speech [5, 6].

Such parallel data is usually generated by artificially distorting clean speech signals. Among the many examples of such databases with artificially generated parallel data are WSJ0-2Mix [7] and SMS-WSJ [8], two data sets for source separation research. For real recordings of degraded speech, parallel data is usually not available. For example, the CHiME-5 [9] and AMI [10] databases offer real recordings of a meeting scenario, but parallel clean speech is not available.

This leaves researchers with a dilemma: while artificial corruption of clean data offers the opportunity to provide parallel data useful for network training, real data are “real”, and artificial degradation can never perfectly mimick true recordings of degraded speech [4].

In this paper we present one of the rare cases of a database which offers both, parallel data and real recordings of degraded speech. It consists of high frequency (HF) speech transmissions recorded by amateur radio receivers. Additionally, the original transmitted clean audio, taken from the LibriSpeech database [11], is available and time synchronized with the recordings. This distinguishes this HF database from the two most recently released HF databases. Both the audio data from the entire Apollo-11 mission, which was released by the University of Texas at Dallas during the “Fearless Step challenge” [12] and the HF data released as part of the DARPA RATS program [13] do not offer parallel data.

Amateur radio (abbrev. “ham radio”) is the non-commercial use of radio frequency spectrum by hobby radio operators. Regulated by the International Telecommunication Union (ITU) [14], the service is intended for research purposes, private conversa-

tions, and even to provide a means for wireless communication in emergency or disaster scenarios.

The database presented in this paper can be used to develop speech activity detection, speech enhancement or signal reconstruction algorithms for speech transmitted over HF communication links. This includes not only the aforementioned amateur radio transmissions, but also several commercial applications of the HF radio spectrum, such as aircraft, police and marine radio.

The database has been generated as follows. Our ham radio station located in Paderborn, Germany, transmitted utterances of the LibriSpeech corpus, which were then received by so-called Kiwi software defined radio (SDR) stations across Europe [15]. A WebSocket connection to the Kiwi stations was established to transmit the received signals back to Paderborn via the internet. The received and transmitted data was then synchronized to obtain the desired parallel data sets.

The developed database is published under the CC BY 4.0¹ license and can be used for research on SAD, speech enhancement, and ASR of speech transmitted over HF radio channels. In this paper we present two baseline systems for SAD: One is based on statistical methods, i.e., Wiener filtering using minimum statistics for noise estimation, and the other utilizes DNNs to solve the task.

The paper is organized as follows: In Sec. 2 the speech data transmission and recording are described, followed by Sec. 3 explaining the two baseline systems where Sec. 3.1 is dedicated to the statistical approach and Sec. 3.2 to the DNN system. After discussing the experimental results in Sec. 4, the paper concludes with Sec. 5.

2 Ham Radio Database

To create the database we transmitted speech signals from our amateur radio station in Paderborn and re-collected the data which has been received in parallel by several Kiwi-SDR stations throughout neighboring countries. Each Kiwi-SDR is separately connected to our servers to transmit the recorded signals back to Paderborn via a WebSocket connection. For the automated transmission the beacon callsign DB0UPB (assigned by the German Telecommunications body “Bundesnetzagentur”) was used. The transmission and recording scheme is depicted in Fig. 1.

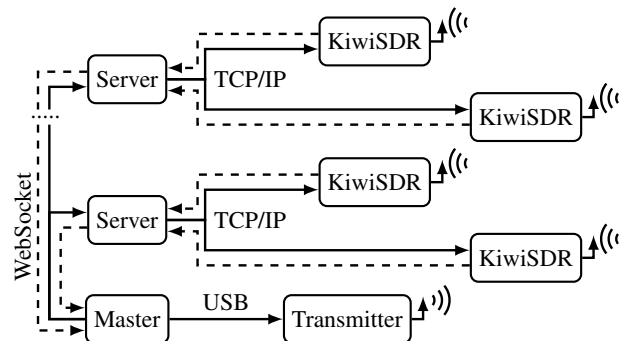

Figure 1: System for distributed recording of radio signals.

Predicted signal quality for the chosen HF carrier frequencies was checked using the web site [16], and appropriate receiver

¹<http://creativecommons.org/licenses/by/4.0/>

stations from regions with good predicted signal quality were selected. The data set includes recordings from stations in Germany, Austria, Switzerland, Belgium, the Netherlands and the United Kingdom.

The signals are single sideband (SSB) modulated using the lower sideband (LSB) with a bandwidth of 2.7 kHz at carrier frequencies of 7.05 MHz – 7.053 MHz and 3.6 MHz – 3.62 MHz. Although, the original audio data has a sampling rate of 16 kHz, and the Kiwi-SDR sampled the data at 12.001 Hz [17], the finally emitted data is band-limited to 2.7 kHz, adhering to transmission regulations from the ITU. In a first processing step the recorded signals are band-limited to 4 kHz via a linear Parks-McClellan filter and downsampled to a rate of 8 kHz.

2.1 Data preparation

The data preparation targets three key issues: First, the recorded data should allow for automatic annotation of speech activity. Second, the data streams of all recording stations have to be synchronized with the emitted audio data to create parallel data. Aligning the clean (transmitted) data and noisy (received) data is important to let the speech activity labels computed on the clean carry over to the noisy data. Finally, it should be possible to automatically decide whether a transmission has been received at each individual station, even in very low signal-to-noise ratio (SNR) conditions.

2.1.1 Annotation process

Our annotation process starts with a carefully conducted data selection and concatenation. The speech samples are taken from the clean training subset of the Librispeech corpus [11], where the subset includes read speech of size close to 500 hrs containing over 1000 speakers.

For this database random segments of 1 s to 8 s length are selected from utterances of the Librispeech corpus. As shown in Fig. 2, we concatenate 5 segments to a single *audio signal sequence*. Each segment is headed and followed by zeros which guarantee silence periods between utterances. The number of zeros here corresponds to a randomly drawn length between 8 s and 30 s.

Subsequently, the speech activity labels for the audio signal sequences are generated as follows: A gaussian mixture model (GMM) hidden Markov model (HMM) acoustic model is trained on the clean training data set of the Librispeech corpus using the KALDI toolkit [18]. This acoustic model is used to calculate forced alignments, and all regions with non-silent labels are declared as containing speech. Additionally, the transcription for each speech segment is generated by extracting the part of the original Librispeech transcription corresponding to the chosen 1 s to 8 s segment using alignment information.

2.1.2 Signal preparation for time synchronization

The Kiwi-SDR receivers record a predefined, fixed frequency band and stream the recorded audio data with an unknown time offset via a WebSocket connection to our servers. This unknown offset has to be determined to synchronize the streams from all Kiwi-SDRs and align them with the clean transmitted signals.

To ease time synchronization, we added markers before and after each transmitted sequence. Each marker has a length of 4 s

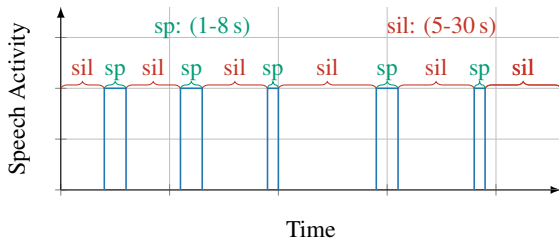

Figure 2: Example of a speech activity sequence over time. Labels “sp” and “sil” represent speech and silence, respectively.

and consists of 26 chirp symbols which differ in starting frequency and orientation (ramp-up or ramp-down). The individual chirp encoding is derived from a gold code to ensure the orthogonality of the markers. In the spectrogram of Fig. 3 a chirp sequence can be seen from frame index 0 to 250.

Our transmission scheme embeds multiple audio signal sequences into one single transmission by surrounding the sequences with markers and concatenating N of them. Additional silence is included after the markers (5 s) and after the audio signal sequences (1 s) to increase the temporal distance between markers and speech. This is an important aspect to mitigate the effect of the Kiwi-SDR’s Automatic Gain Control (AGC). The AGC correctly reacts on the marker and raises the gain, however, in a real audio transmission no preliminary warning is given to the receiver that audio is coming next. Therefore, the time between the marker and the signal has to be long enough so that the AGC readjusts the gain to the original level to get realistic recordings. The beginning of one transmission scheme is shown in Fig. 3.

2.1.3 Marker based time synchronization

The recorded Kiwi-SDR audio streams are examined in the short-time Fourier transform (STFT) domain. Here, the marker’s STFT acts as a binary mask which is shifted along the audio stream to find the temporal shift with maximum correlation. Beneficially, the markers are orthogonal to each other and the length of 4 s enables a reliable detection even in low SNR conditions.

The marker detection process delivers a set of hypotheses for marker positions in the stream. A stream is segmented according to the marker positions and the data is considered valid if the following sanity checks are fulfilled:

- All markers of a transmission are detected.
- All markers are detected in the expected order.
- All time differences between markers exactly match the expected timing.

The third condition ensures that audio streams with dropped samples are discarded and that the synchronization error cannot exceed 16 ms.

Fig.4 shows synchronized recordings of the same transmitted audio sample received by three different Kiwi-SDR stations. While some stations deliver audio signals with only few distortions, e.g., Hagenow in Fig. 4, others suffer from bad propagation conditions resulting in low Short-time Objective Intelligibility (STOI) measures [19], e.g., Newmarket.

2.1.4 Post processing

The recorded signal has a small sampling rate offset due to the assumption that a 12 kHz is recorded which is a 1 Hz deviation from the true sampling rate. We correct this sampling rate offset of 56 ppm using the approach described in [20] as a post processing step after downsampling.

Furthermore, the marker based synchronization is improved by estimating the delay between the clean signal and the recorded signal and corrected if necessary. Therefore, we estimate the delay of each segment with speech activity using GCC-Phat [21] and

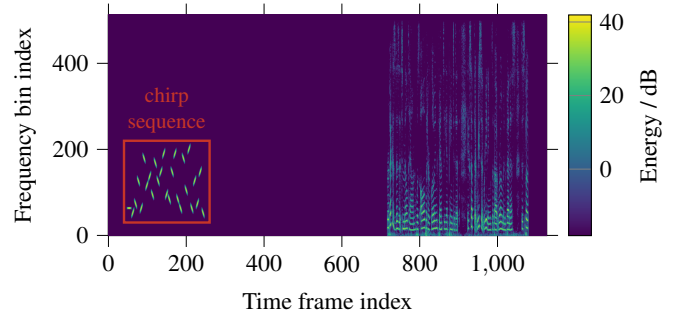

Figure 3: Example of a transmitted chirp sequence and the following audio signal

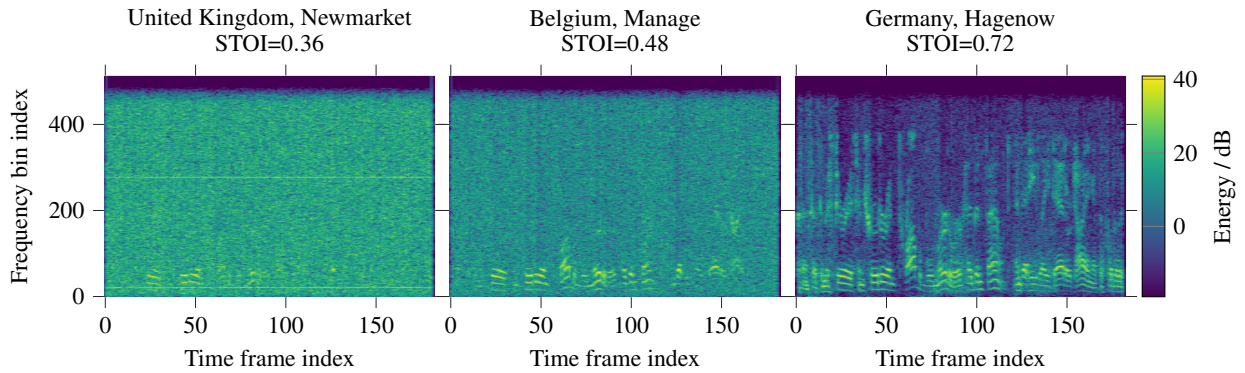

Figure 4: Received signals of three stations recording the same transmitted signal.

calculate the median over all delays in a recorded sequence. If the estimated delay is greater than 16 ms, indicating a delay much greater than would be expected from marker-based synchronization, an error due to low SNR values is assumed and the signals are left unchanged.

2.2 Concurrent speakers

Some of the recordings are accidentally corrupted by co-/adjacent channel interferences caused by transmissions from other ham radio users. Some users did not understand the English content explaining the transmission purpose and asked our automatic beacon to leave the frequency. Others did not check the frequency carefully enough and selected transmission frequencies too close to ours. Their signals are transmitted at neighboring frequencies, and, depending on the proximity, are hardly understandable. Their speech poses a unique challenge to speech enhancement and reconstruction. In the data these regions are, obviously, not marked as containing speech, as they have not been transmitted by us. As a consequence a few percent of the labels may not reflect true absence of speech.

2.3 Download

The database can be downloaded from <https://zenodo.org/record/4247491> and code examples on how to train and evaluate a neural network for SAD on the presented data can be found in https://github.com/fgnt/ham_radio. The database is published under the CC BY 4.0 license and is thereby free to use for any purpose, be it commercial or non-commercial.

3 Speech Activity Detection

Both the DNN based SAD and the statistical SAD are similar to the ones we proposed in [22]. The following sections present a short overview over the systems.

3.1 Statistical SAD

The statistical SAD processes the data in two phases. In the first phase the background noise is reduced by Wiener filtering, whose noise power spectral density (PSD) is estimated by minimum statistics. The gain function of the Wiener filter is given by

$$W(t, f) = \max \left(1 - \gamma \frac{|V(t, f)|^2}{|X(t, f)|^2}, G_{\min} \right). \quad (1)$$

with G_{\min} denoting a lower bound on the Wiener filter gain. Here, the STFT-coefficients of the observed signal $X(t, f)$ with t as the frame index and f as the frequency bin index are used to determine the noise PSD $|V(t, f)|^2$ and the PSD of the current analysis window $|X(t, f)|^2$.

Since the Kiwi-SDR's AGC adapts to the receiver channel conditions, the noise level of the recordings is changing rapidly over

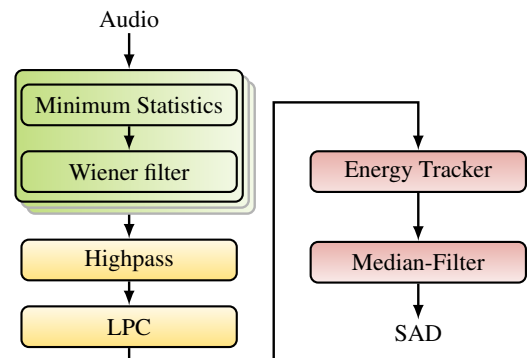

Figure 5: Overview on statistical SAD components and signal processing queue.

time. Hence, the observation window of the minimum statistics for estimating $|V(t, f)|^2$ has to be kept small, and the oversubtraction factor γ has to be chosen quite large ($\gamma > 20$). Noise PSD estimation and Wiener filtering is repeated several times to maximize the SNR gain. Following the multi-stage Wiener filter, a linear highpass is applied to remove low frequency noise. Afterwards, a simple 1st-order linear predictive coding (LPC) filter suppresses all parts of the signals that are not as well predictable as the highly correlated speech signals.

In the second phase temporally smoothed sub-band energies and an adaptive threshold are calculated to decide on speech activity. Figure 5 depicts a block diagram of the statistical SAD system.

3.2 DNN based SAD

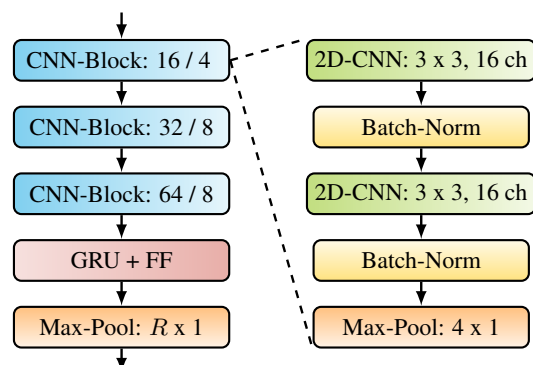

Figure 6: Block diagram of the DNN architecture for speech activity detection, where R represents the output size of the FF layer.

Since the Fearless Steps challenge database [12] also offers HF transmission data, the best performing SAD system [22] from

the 2020 challenge is adapted to the new database. Fig. 6 shows the block diagram of the architecture of the DNN for SAD.

The STFT input data is first normalized using a ℓ_2 -norm over the time dimension to compensate for possible variations in the signal due to different recording devices, distance to the transmitter or speaker. The normalized signal is processed by several convolutional neural network (CNN) blocks with subsequent temporal smoothing as shown in the figure. The CNN output is then processed by two uni-directional gated recurrent unit (GRU) layers [23] followed by a feed forward (FF) classification layer and max pooling over the feature dimension. All CNN blocks consist of two 2D-CNN layers with batch normalization and max pooling over the feature dimension. Note, that no pooling is applied to the time dimension to allow a frame-wise activity estimation. The purpose of the GRU is to gather temporal information from a larger context than the CNN layer. During evaluation the network output is smoothed using a simple median filter over 25 frames.

4 Experiments

The recorded database is split into the following three data sets: training, development and evaluation. Each set includes data recorded by about 22 different KiwiSDR stations. The speakers are strictly disjoint among the three sets and the speakers are uniformly distributed between female and male over the whole database. No speaker is active in more than one example.

To classify the degree of distortion of each example we measured the SDR [24] and the short time objective intelligibility (STOI) score [19]. Both metrics require the availability of clean and distorted data as provided by this database.

In Fig 7 the histograms of SDR and STOI values in the evaluation set are presented, illustrating the diversity of channel conditions represented by the database. The low SDR values can be explained by the AGC which significantly changes the signal amplitudes compared to the original clean signal. Thereby, leading to very low SDR values even in case of low noise energy levels. This is a challenge for many current neural network based enhancement systems which rely on SI-SDR loss functions [25].

Table 1 summarizes the duration, the percentage of speech activity, the number of speakers, as well as the average values of SDR and STOI, for the training, development and evaluation set, respectively. For all data sets the percentage of speech activity is close to 13%. Therefore, the database includes a large amount of ham radio noise which could be used for data augmentation.

To evaluate the SAD systems, we used the OpenSAD challenge scoring [26] with a collar of 0.5 s around both the beginning and end of each segment, i.e., speech on/offset errors below that value were not counted as an error.

We use precision (P), recall (R) and F_1 -score= $2(P \cdot R)/(P + R)$ as metrics with

$$P = \frac{TP}{TP + FP}, \quad (2) \quad R = \frac{TP}{TP + FN}, \quad (3)$$

where TP, FP, TN and FN are the number of true positive, false positive, true negative and false negative predictions. For the experiments the following STFT parameters are used:

- DNN SAD: FFT size 256, 10 ms shift, 25 ms window length
- Stat. SAD: FFT size 1024, 32 ms shift, 64 ms window length

Furthermore, the number of hidden units is set to 514 for the GRU and to 10 for the FF classifier layer.

	Training	Development	Evaluation
Duration / h	121	18	37
Speech / %	13.90	12.58	13.16
# Speakers	705	80	175
Average SDR / dB	-8.80	-8.31	-7.91
Average STOI	0.63	0.64	0.61

Table 1: Statistics of the different data sets.

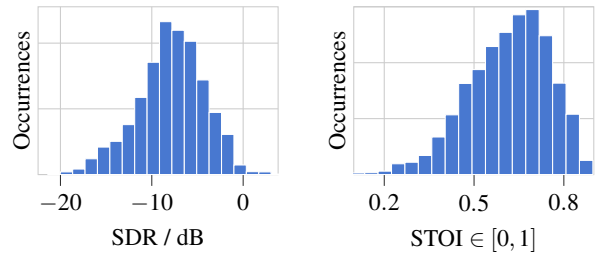

Figure 7: Histogram of STOI and SDR values on evaluation data.

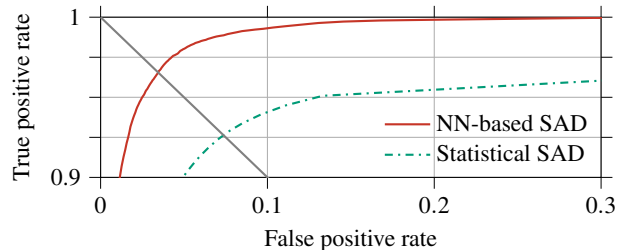

Figure 8: ROC curves of the SAD systems for the development data set. At the intersection with the straight gray line the equal error rate can be read off.

The results for the DNN and the statistical SAD on the development data set are displayed in terms of a receiver operating characteristic (ROC) curve in Figure 8. From the ROC curve the threshold corresponding to the equal error rate is determined for each system on the development data set and then applied on the evaluation data set. The results are shown in Table 2.

The DNN outperforms the statistical SAD on both the development and evaluation data set. However, the statistical SAD using a C implementation has a significantly lower realtime (RT) factor than the DNN implemented in Pytorch [27]. The real-time (RT) factor is calculated on an Intel® Xeon® CPU E3-1240 v6 @ 3.70GHz with 8GB RAM. For both systems all detection metrics are lower compared to the values obtained on the 2020 Fearless challenge [22] which emphasizes the difficulty of the presented database.

System	R	P	F1-score	RT-factor
Statistical	85.90	93.24	89.42	0.0047
DNN based	95.59	95.65	95.62	0.0119

Table 2: Results of different SAD systems on the evaluation data set, where the SAD threshold has been determined on the development set.

5 Summary

In this paper we presented a database of real ham radio recordings with parallel clean and distorted speech data, offering a novel challenge for speech activity detection, enhancement, and reconstruction. The database consists of diverse noise conditions with a SDR ranging from -20 db to 5 dB. Additionally, two baseline systems for SAD are presented. In future work, we will evaluate speech enhancement and reconstruction algorithms on this new database.

6 Acknowledgements

Computational resources were provided by the Paderborn Center for Parallel Computing.

References

- [1] S. Watanabe, M. Delcroix, and F. Metze, *New Era for Robust Speech Recognition: Exploiting Deep Learning*. Springer Publishing Company, Incorporated, 2018.
- [2] R. Haeb-Umbach, S. Watanabe, T. Nakatani, M. Bacchiani, B. Hoffmeister, M. L. Seltzer, H. Zen, and M. Souden, "Speech processing for digital home assistants: Combining signal processing with deep-learning techniques," *IEEE Signal Processing Magazine*, vol. 36, no. 6, pp. 111–124, 2019.
- [3] R. Haeb-Umbach, J. Heymann, L. Drude, S. Watanabe, M. Delcroix, and T. Nakatani, "Far-field automatic speech recognition," *Proceedings of the IEEE*, vol. 109, no. 2, pp. 124–148, 2021.
- [4] J. Heymann, M. Bacchiani, and T. N. Sainath, "Performance of mask based statistical beamforming in a smart home scenario," in *2018 IEEE International Conference on Acoustics, Speech and Signal Processing (ICASSP)*, pp. 6722–6726, April 2018.
- [5] H. Erdogan, J. R. Hershey, S. Watanabe, and J. Le Roux, "Phase-sensitive and recognition-boosted speech separation using deep recurrent neural networks," in *2015 IEEE International Conference on Acoustics, Speech and Signal Processing (ICASSP)*, pp. 708–712, 2015.
- [6] M. Kolbaek, D. Yu, Z. Tan, and J. Jensen, "Multitalker speech separation with utterance-level permutation invariant training of deep recurrent neural networks," *IEEE/ACM Transactions on Audio, Speech, and Language Processing*, vol. 25, pp. 1901–1913, Oct 2017.
- [7] Z. Wang, J. Le Roux, and J. R. Hershey, "Multi-channel deep clustering: Discriminative spectral and spatial embeddings for speaker-independent speech separation," in *IEEE International Conference on Acoustics, Speech and Signal Processing (ICASSP)*, pp. 1–5, April 2018.
- [8] L. Drude, J. Heitkaemper, C. Boeddeker, and R. Haeb-Umbach, "SMS-WSJ: Database, performance measures, and baseline recipe for multi-channel source separation and recognition," *CoRR*, vol. abs/1910.13934, 2019.
- [9] J. Barker, S. Watanabe, E. Vincent, and J. Trmal, "The fifth 'CHiME' Speech Separation and Recognition Challenge: Dataset, task and baselines," in *Proceedings of the 19th Annual Conference of the International Speech Communication Association (INTERSPEECH 2018)*, (Hyderabad, India), Sept. 2018.
- [10] I. McCowan, J. Carletta, W. Kraaij, S. Ashby, S. Bourban, M. Flynn, M. Guillemot, T. Hain, J. Kadlec, V. Karaiskos, M. Kronenthal, G. Lathoud, M. Lincoln, A. Lisowska Mason, W. Post, D. Reidsma, and P. Wellner, "The ami meeting corpus," *Int'l. Conf. on Methods and Techniques in Behavioral Research*, Jan 2005.
- [11] V. Panayotov, G. Chen, D. Povey, and S. Khudanpur, "Librispeech: An asr corpus based on public domain audio books," in *2015 IEEE International Conference on Acoustics, Speech and Signal Processing (ICASSP)*, pp. 5206–5210, April 2015.
- [12] J. Hansen, A. Sangwan, A. Joglekar, A. Bulut, L. Kaushik, and C. Yu, "Fearless steps: Apollo-11 corpus advancements for speech technologies from earth to the moon," in *Proceedings of the 21st Annual Conference of the International Speech Communication Association (INTERSPEECH 2018)*, pp. 2758–2762, Sep 2018.
- [13] K. Walker and S. Strassel, "The rats radio traffic collection system," in *Proceedings of Odyssey 2012 - The Speaker and Language Recognition Workshop*, pp. 291–297, June 2012.
- [14] Regulations and Publication, *International Telecommunication Unit*, 2021 (accessed July 21, 2021). <https://www.itu.int/en/publications>.
- [15] J. Seamons, *Kiwi-SDR*, 2021 (accessed July 21, 2021). <http://kiwisdr.com>.
- [16] O. H. Predictions, *VOACAP*, 2021 (accessed July 21, 2021). <https://www.voacap.com/hfbc/>.
- [17] *Kiwi-Client*, 2021 (accessed July 21, 2021). <https://github.com/jks-prv/kiwiclient>.
- [18] D. Povey, A. Ghoshal, G. Boulianne, L. Burget, O. Glembek, N. Goel, . Hannemann, P. Motlicek, Y. Qian, P. Schwarz, J. Silovsky, G. Stemmer, and K. Vesely, "The Kaldi speech recognition toolkit," in *IEEE 2011 Workshop on Automatic Speech Recognition and Understanding*, IEEE Signal Processing Society, Dec 2011.
- [19] C. H. Taal, R. C. Hendriks, R. Heusdens, and J. Jensen, "An algorithm for intelligibility prediction of time-frequency weighted noisy speech," *IEEE Transactions on Audio, Speech, and Language Processing*, vol. 19, no. 7, pp. 2125–2136, 2011.
- [20] J. Schmalenstroerer and R. Haeb-Umbach, "Efficient sampling rate offset compensation - an overlap-save based approach," in *2018 26th European Signal Processing Conference (EUSIPCO)*, pp. 499–503, 2018.
- [21] C. Knapp and G. Carter, "The generalized correlation method for estimation of time delay," *IEEE Transactions on Acoustics, Speech, and Signal Processing*, vol. 24, no. 4, pp. 320–327, 1976.
- [22] J. Heitkaemper, J. Schmalenstroerer, and R. Haeb-Umbach, "Statistical and Neural Network Based Speech Activity Detection in Non-Stationary Acoustic Environments," in *Proceedings of the 21st Annual Conference of the International Speech Communication Association (INTERSPEECH 2020)*, (Shanghai, China), 2020.
- [23] K. Cho, B. van Merriënboer, Ç. Gülçehre, F. Bougares, H. Schwenk, and Y. Bengio, "Learning phrase representations using RNN encoder-decoder for statistical machine translation," *CoRR*, vol. abs/1406.1078, 2014.
- [24] E. Vincent, R. Gribonval, and C. Févotte, "Performance measurement in blind audio source separation," *IEEE Transactions on Audio, Speech, and Language Processing*, vol. 14, no. 4, pp. 1462–1469, 2006.
- [25] Y. Luo and N. Mesgarani, "TasNet: Surpassing ideal time-frequency masking for speech separation," *CoRR*, vol. abs/1809.07454, 2018.
- [26] NIST U.S. Department of Commerce, *NIST Open Speech-Activity-Detection Evaluation*, 2016 (accessed July 21, 2021). https://www.nist.gov/system/files/documents/itl/iad/mig/Open_SAD_Eval_Plan_v10.pdf.
- [27] A. Paszke, S. Gross, F. Massa, A. Lerer, J. Bradbury, G. Chanan, T. Killeen, Z. Lin, N. Gimelshein, L. Antiga, A. Desmaison, A. Kopf, E. Yang, Z. DeVito, M. Raison, A. Tejani, S. Chilamkurthy, B. Steiner, L. Fang, J. Bai, and S. Chintala, "Pytorch: An imperative style, high-performance deep learning library," in *Advances in Neural Information Processing Systems 32*, pp. 8024–8035, Curran Associates, Inc., 2019.