

---

# REVIEW OF INTEGRATED PHOTONIC ELASTIC WDM SWITCHES FOR DATA CENTERS

---

A PREPRINT

**Akhilesh S P Khope**  
Microsoft Corporation  
One Microsoft Way  
Redmond, WA, 98052  
akhkhope@gmail.com

**Anirban Samanta, Xian Xiao, Ben Yoo**  
Department of Electrical And Computer Engineering  
One Shields Avenue, Kemper Hall  
University of California  
Davis, CA 95616

**John E Bowers**  
Department of Electrical And Computer Engineering  
University of California  
Santa Barbara, CA, 93106

June 1, 2021

## ABSTRACT

In this review paper, we present an elaborate discussion on wavelength selective switches and their demonstrations. We also review packaging and electronic photonic integration of switches; a topic neglected in other review papers. We also cover wavelength locking which is paramount in switching networks with many tunable filters.

**Keywords** Switching · Silicon Photonics · Photonic Integrated Circuits

## 1 Introduction

Switch is a device used to turn off and on a connection between two ports. If  $N$  terminal devices like telephones or computer servers are connected to each other, switch can reduce the number of connections from  $N(N - 1)$  to  $2N$  and also intelligently provision bandwidth according to demand. One of the first demonstrations of a crossbar switch was in 1915 Craft and Reynolds [1915], the switch was an electromechanical switch used for switching telephone calls. Widespread use of crossbar switches is reported in Sweden in 1926 and later in 1938 in AT&T Bell Labs.

Larger port count switches are hard to manufacture and thus Charles Clos created an ingenious way of creating a bigger network from smaller switches in 1953 Clos [1953]. Many datacenter architectures follow a modified version of this architecture called fat tree topology. Switching networks as well as switches which form them can be either blocking, strictly non blocking or reconfigurable non blocking. For a detailed discussion on this, reader is advised to read Beneš [1965]. In this paper, many of the integrated photonic switches reported are rearrangeably non-blocking as their configuration changes according to an arbitrator on a global clock. With the miniaturization of devices in Silicon Photonics, advances in lasers and Semiconductor Optical Amplifiers (SOAs) in III-V platforms and tight electronic and photonic integration through fabless photonic foundries it is now possible to fabricate and integrate larger port count switching networks on a single chip.

The communication patterns in the today's high performance computing and datacenter systems are spatially and temporally non-uniform, which means the bursty bandwidth requirement in some data links could cause heavy congestion. However, today's electronic switches based interconnections have a fixed topology, which is incapable of dynamically adapting the bandwidth to the workloads. In recent years, several optical bandwidth-reconfigurable

switching fabrics have been demonstrated by using wavelength-and-space selective optical switches. By utilizing wavelength division multiplexing (WDM) technologies, such switches can achieve bandwidth steering by reconfiguring the number of wavelength channels in selected pairs of nodes while maintaining the benefit of optical switching, including higher speed and lower power consumption.

Architecture of most of the switches reported in this review consists of a wavelength division multiplexed (WDM) signal at the input of an integrated photonic switch and a receiver with a demux. Integrated photonic switches can be categorized into broadband/fiber switches and wavelength selective switches (WSS). Wavelength selective switches can be further categorized into single wavelength selective and elastic/multiwavelength selective switches. In broadband switches, the entire WDM signal from one port is switched to another port. In single wavelength selective switches connection between ports has only one wavelength connection between ports, and if one changes the input wavelength at input port the signal is received at a different output port. In elastic/multiwavelength selective switch, different ports can be connected to each other using one or more than one wavelength from the WDM signal.

In the following two paragraphs, we report some data center architectures with WSS from literature. Such switches can be integrated into datacenter networks and high performance computing clusters with some modification. Fig. 1(a) shows a data center network with multi degree WSS mesh connecting different server groups reported by Google in Zhao et al. [2016]. The optical switches in the WSS mesh can increase network scalability and result in fewer physical links between elements of the data center network which results in reduced hardware and network cost. Fig. 1(b) shows a datacenter architecture with WSS in a multidimensional interconnection network called Hyper-X is reported in Saleh et al. [2016]. Hyper-X requires very dense fiber connections for large radix HPC and datacenter networks and the induction of WSS switches enables reconfigurability and results in simplifying wiring.

Fig. 1(c) shows a method of designing networks based on AWGs and WSSs is reported in Lin and Lea [2017]. This method is more flexible in terms of construction of different switch sizes. Another method for constructing such networks is reported by the same group in Huang and Lea [2016]. Fig. 1(d) shows a switch with broadband photonic switch and WSS for switching between top of the rack switches is reported in Xu et al. [2011]. Fig. 1(e) shows an AWGR based architecture for datacenters (citation). Fig. 1(f) shows an Optical Top Of the Rack (OTOR) architecture that can be integrated into a software defined network (SDN) enabled datacenter architecture with dynamic bandwidth allocation using WSS Xue et al. [2020]. Fig. 1(g) shows application of IRIS WSS used as a transponder aggregator for Reconfigurable Optical Add Drop Multiplexers (ROADMs) Testa et al. [2018].

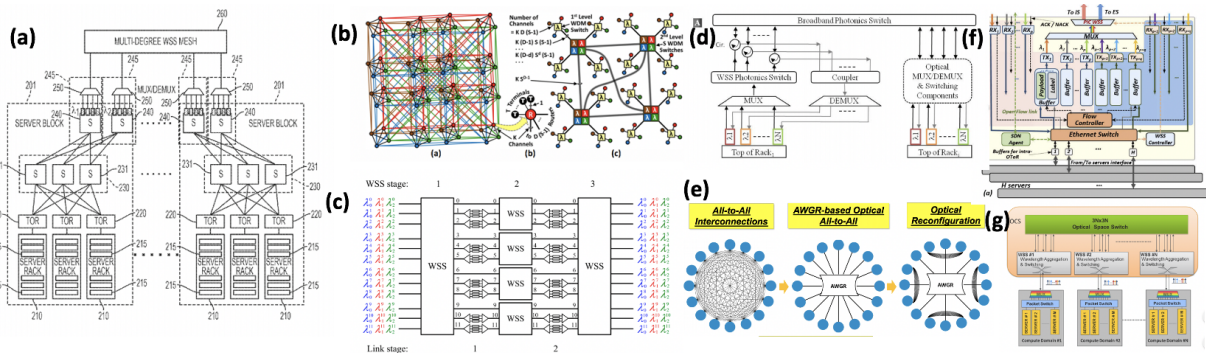

Figure 1: (a) check this again , Dynamic datacenter network with Multi-Degree WSS mesh, (b) HyperX topology for WSS (bigger) , (c) Non-blocking wavelength space switches with WSSs Lin and Lea [2017], (d) switching between top of the rack switches, (e) application of AWGR based switches in datacenters, (f) photonic top of the rack switch (g) application of IRIS WSS ROADMs

There have been numerous reviews on photonic switching and datacenter technologies Cheng et al. [2018a], Lee [2017], Shen et al. [2019], Cheng et al. [2018b], none of them have covered integrated photonic elastic WDM switches.

The main difference between our paper and the other recently published review papers is:

1. we do an in depth review of integrated photonic elastic WDM switches as compared to other papers.
2. we do an in depth review of packaging and integration of the switches with electronics.
3. we also cover wavelength locking and stabilization.

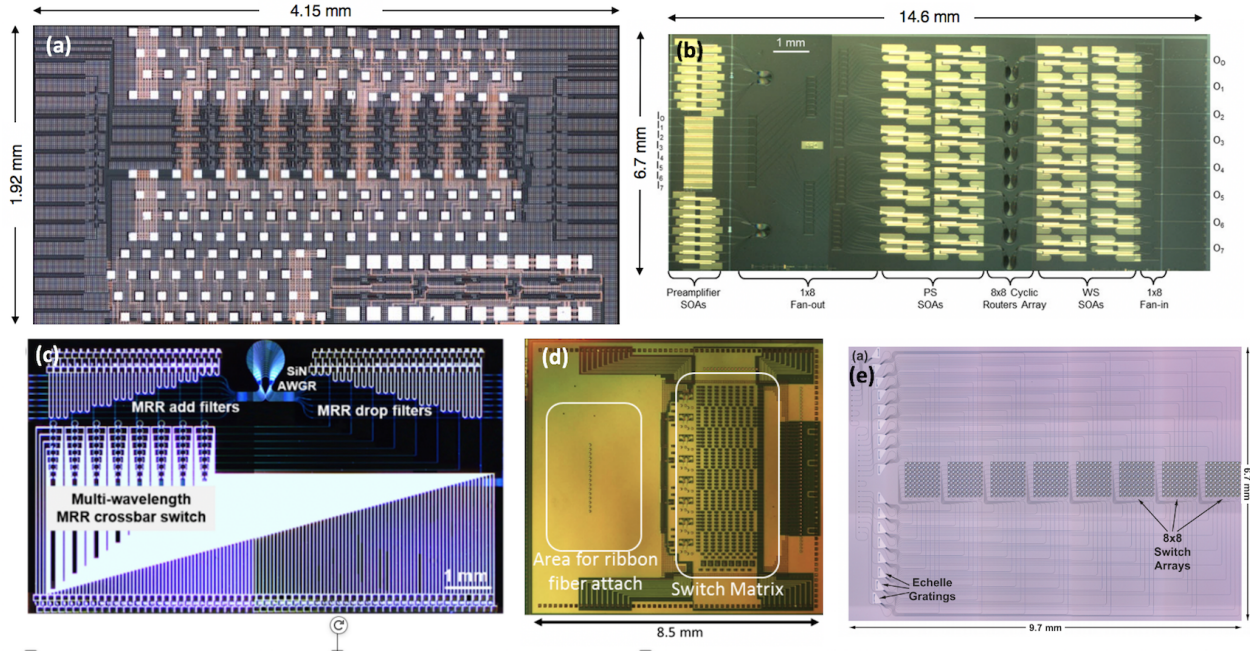

Figure 2: (a) 8x4 switch reported in Khope et al. [2019], (b) 8x8 SOA based switch reported in Stabile et al. [2013], (c) Flex ions based switch reported in Xiao et al. [2019], (d) Reconfigurable silicon photonic ROADM is reported in Testa et al. [2016, 2018], (e)  $8 \times 8 \times 8$  SiP MEMS switch is reported in Seok et al. [2019]

In Section II of this review, we review integrated photonic architectures. In Section III, we compare different switching devices. In Section IV, we review demonstrations of wavelength selective switches. In Section VI, we discuss packaging technologies for both broadband and WSS. In Section VII, we discuss wavelength locking and stabilization.

## 2 Architectures

Smaller switches can be arranged in different architectures according to application. WSS can be arranged in the following architectures (Maybe diagram):

- Layered architecture
- Crossbar
- AWGR based switches

All switching architectures have  $N$  input ports,  $N$  output ports and  $M$  wavelengths at each input.

**Crossbar switch:** In this arrangement there are upto  $M$  ring resonators at each intersection. There are  $MN^2$  switching elements. Optical path loss is path dependent.

**Layered switch :** In this arrangement,  $N$  demultiplexers routes  $M$  wavelengths to  $M \times N \times N$  single wavelength switches and these are connected to  $N$  multiplexers. Single wavelength switches in this arrangement can be AWGRs, Crossbar switches, Benes switches and any other non blocking switching arrangement. This type of switch can be built in a silicon photonic platform or III-V platform using SOAs. There are  $MN^2$  switching elements if using crossbar as a switching element.  $M + 2N$  switching elements if using cyclic AWGRs, multiplexer and demultiplexer.  $MN \log N$  switching elements is a Benes network is used. Authors in Wagner et al. [1996] reported MONET, a layered switch for metro and long haul networks.

**AWGR based architecture:** In this arrangement,  $M$  tunable lasers are used at each  $N$  ports. A cyclic AWGR is used to route wavelengths to different ports based on the input wavelength from tunable lasers. There are  $2MN$  active elements (tunable lasers).

### 3 Demonstration of switches

In multi-wavelength switches, in addition to all to all extra connections can be provisioned between nodes as per demand. This reconfiguration provides superior latency when load is higher as compared to fixed connectivity all to all switches. These switches also require a control plane for arbitration. Multi-wavelength crossbar MRR based switches fabricated in silicon photonics foundries are reported in Khope et al. [2017a, 2019]. The authors switch in Khope et al. [2016] and we carry out architectural exploration in Saleh et al. [2016]. These switches have upto two wavelength connectivity per connection and provide latency comparable to that of full wavelength connectivity. Cyclic Arrayed Waveguide Grating Router (AWGR) based switches are reported in Flex Lions Xiao et al. [2020]. These family of switches use two FSRs of the AWGR, to provide multi-wavelength connectivity. Fully flexible switches are reported in MRR based Benes network Goebuchi et al. [2008] and a layered wavelength selective 8x8x8 MEMS switch reported in Seok et al. [2018]. A switch and select switch is reported in Polarization-Diversity MRR based switch fabric Yang et al. [2020]. A crossbar switch capable of joint unicast and multi-cast functionality is reported in Su et al. [2015]. In this switch architecture an all to all connectivity is provided by partial drop MRR and full connectivity is provided on demand by a full power drop MRR. A 2x2 2 channel WSS with unlimited free spectral range using contra directional grating couplers is reported in Ikeda et al. [2020]. A multicast and multi wavelength selective switch is reported Khope et al. [2021a,b]. Multi-wavelength selective switch experiments are also reported in Khope et al. [2020]. Push—pull microring-assisted space-and-wavelength selective switch crossbar switch is reported in Huang et al. [2020].

A  $1 \times 2$  WSS MRR based on nested pairs of subrings is demonstrated in Wu et al. [2015]. A  $1 \times 2$  wavefront control type WSS was reported using silicon waveguides in Nakamura et al. [2018a]. A  $2 \times 2$  WSS with four wavelength channels, thermo optic MZ switches and MRRs with a wavelength transmittance change of 9.7 dB is reported in Miura et al. [2012]. A silicon based  $1 \times 2$  WSS with foldback AWG is reported in Nakamura et al. [2018b]. A  $4 \times 4 \times 4$  hitless MRR based non blocking switch is reported in Goebuchi et al. [2008]. A monolithic  $1 \times 2$  WSS gridless switch in silicon and silicon nitride waveguides is reported in Doerr et al. [2011]. A 200 GHz, 17 channel  $1 \times 2$  SiP WSS with AWG loopback is reported in Asakura et al. [2015]. This switch reported losses from 21 dB to 26 dB and a crosstalk range of -21 to -2 dB. A flexible grid  $1 \times 2$  WSS in SiP with 9 MRR is reported in Wang et al. [2017] with a crosstalk lower than -11.5 dB and a maximum tuning bandwidth of 4.09 nm.

A 2x2 microring based WSS is reported in Xu et al. [2011], Lira et al. [2009]. A scalable 2x2 crossbar silicon photonic switch is reported in Li et al. [2015]. A SiP mode and wavelength switch is reported in Velha et al. [2015]. A high speed 2x2 SiP multi-wavelength switch is reported in Lee et al. [2009], maybe similar paper Lee et al. [2008]. A MRR based cascaded SiP ring crossbar switch is reported in Poon et al. [2008]. An AWGR based WSS is reported in Yu et al. [2013]. A slow light based WSS using photonic crystals is reported in Beggs et al. [2008]. A thermo optic photonic crystal based switch 2x2 is reported in Zhou et al. [2017]. Wavelength-selective  $2 \times 2$  optical switch based on a Ge<sub>2</sub>Sb<sub>2</sub>Te 5-assisted microring Zhang et al. [2020]. A  $2 \times 2 \times 2\lambda$  switch is reported in Huang et al. [2020]. A layered switch with switch and select stages is proposed in Cheng et al. [2019].

InP based switches have a larger footprint for the same switch radix and are typically built using SOAs. These switches can have zero net optical loss. A 8x8 wavelength and space cross-connect is reported in InGaAsP/InP platform with  $1 \times 8$  broadband selection stages and  $8 \times 8$  gated cyclic routers in Stabile et al. [2013]. A  $1 \times 8$  optical module of a  $8 \times 8 \times 8\lambda$  wavelength selective switch and select architecture with SOAs in InP is reported in Prifti et al. [2018]. SiP switches with integrated SOAs can provide zero optical path loss and are reported in Konoike et al. [2018]. A tunable 2x2 WSS in SiO<sub>2</sub>-Si<sub>3</sub>N<sub>4</sub> is reported in Geuzebroek et al. [2005]. AWGR in flex lions is on top of silicon.

## 4 Packaging

Packaging of photonic circuits requires consideration of optical, electrical, thermal and mechanical challenges of integrating photonic circuits to off-chip interfaces. In terms of signal transmission the two main domains are the optical fiber-to-waveguide coupling and integration with electronics.

### 4.1 Fiber-to-waveguide Coupling

#### 4.1.1 Grating Coupler

A Bragg diffraction grating structure of periodic or chirped design is utilized to vertically couple light to and from an off-chip fiber, making this technique wavelength dependent, resulting in narrow bandwidth, wavelength and polarization sensitivity. They tend to be compact, have high alignment tolerance, simpler wafer-scale testing and high volume manufacturing. Fabricated grating couplers with more than 70% measured coupling efficiency have been demonstrated Marchetti et al. [2017], Kang et al. [2020].



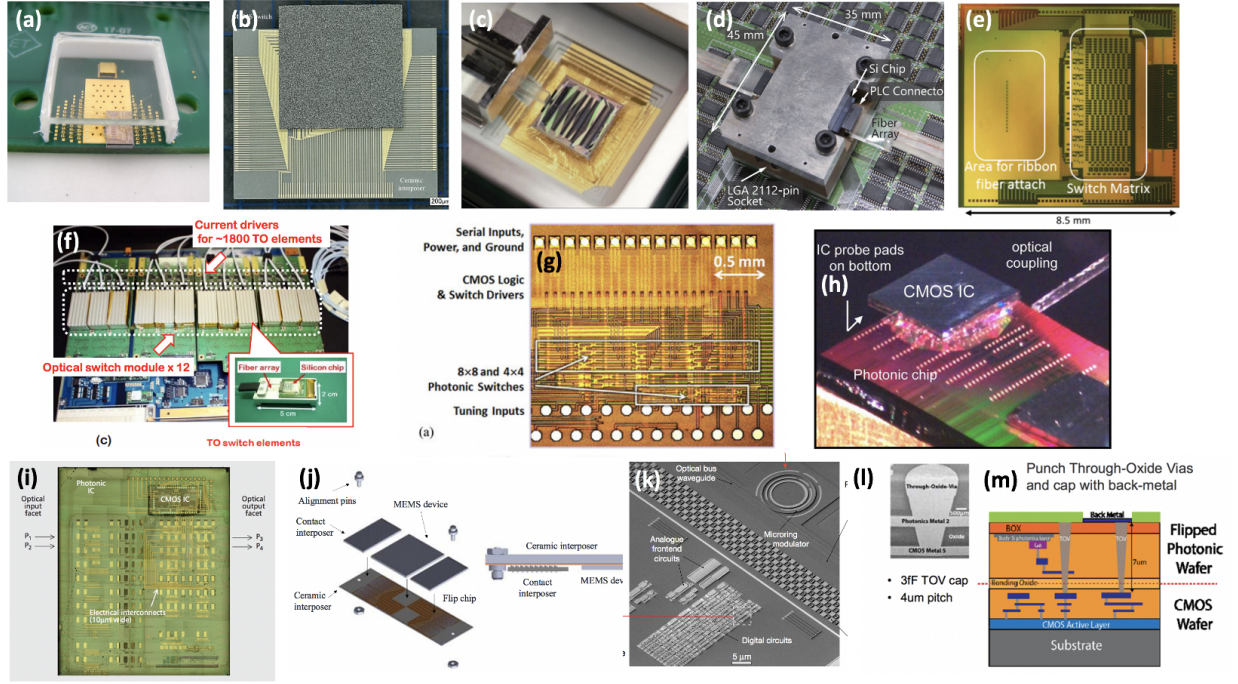

Figure 3: (a) Switch die integrated onto a PCB with overhang for edge coupling as reported in Khope et al. [2019], (b) MEMS switch flip-chip packaged on a ceramic package reported in Hwang et al. [2017a], (c) SiPh switch die wirebonded in a CBGA package reported in Dumais et al. [2017], (d) Switch die mounted on a PCB with control electronics reported in Suzuki et al. [2019], (e) Switch PIC with grating couplers for vertical coupling of light reported in Testa et al. [2018], (f) A transponder system with switch module packaged with fiber array reported in Nakamura et al. [2016], (g) Monolithic photonic switch system-on-chip reported in Lee et al. [2013], (h) CMOS driver IC flip-chip bonded onto photonic chip for 3D vertical integration as reported in Rylyakov et al. [2011], (i) Heterogeneous integration of CMOS die into a cavity of a PIC die followed by further processing to establish metallic contacts as reported in Chen et al. [2013], (j) A pluggable SiPh switch concept reported in Hwang et al. [2018], (k) Monolithic integration of active photonic devices reported in Atabaki et al. [2018], (l) Through-oxide via (TOV) technology for vertical integration of electronic interconnect and (m) Backside processing of flipped photonic die to form TOVs reported in Settaluri et al. [2015] and Stojanović et al. [2015]

#### 4.1.2 Edge Coupler and Evanescent Coupler

An edge coupler consists of an inverse taper section where the waveguide width is gradually reduced to a fine tip. As the guided wave propagates along the taper, it becomes less confined and its effective cross-section increases. The expanded wave can then be coupled into a lensed fiber. Edge coupling can be more efficient than grating couplers, with up to 90% efficiency Takei et al. [2013], however they require highly polished facets to achieve high efficiency necessitating complex fabrication processes. Usually long tapers are required for adiabatic functioning, and they also suffer from mode mismatch challenges. Evanescent coupler is an extension of the edge coupling concept. Instead of coupling light into a fiber at the edge, the expanded mode is coupled into another tapered waveguide fabricated in another PIC or interposer with optical fibers pre-attached Dangel et al. [2015]. It offers the advantages of edge coupling along with relaxed alignment tolerances characteristic of grating couplers.

## 4.2 Electronic Packaging

Photonic circuits need to be driven by electronics and the high speed nature of the signals require careful design of the electrical interconnect in order to control the impedance values and electrical crosstalk. Electrical pads on photonic chips are connected to electrical pads on driver asics, and these connections are finally connected to the PCB. The pad pitch of both photonic and electronic chips is much smaller than pad pitch of PCB. The mismatch in pitch between PCB and chip can be circumvented by using an intermediary interposer or package with an organic or ceramic ball grid array (BGA). The interconnection is usually done with wire bonds or through vertical integration methods.

### 4.2.1 Wire bonding

If the number of electrical connections is low (typically less than 400), wire bonding offers a simple solution where bare metal wires are used to connect PIC contact pads on the top surface to a leadframe on an organic or ceramic BGA package Dumais et al. [2018]. These packages typically support  $150\ \mu\text{m}$  or more in contact pitch with the backside ball grid array pitch being 0.5 mm or more. Wire bonds tend to have higher impedance values limiting electrical performance.

### 4.2.2 Vertical integration

When a large number of contacts, dense electrical I/O or higher electrical performance is necessary, vertical integration becomes critical. Vertical integration with flip-chip bonding or by using through silicon vias (TSVs) and through oxide vias (TOVs) can reduce the length of electrical interconnect to the order of the IC thickness (100s of  $\mu\text{m}$ ) compared to many millimeters in wire-bonded solutions, reducing the parasitic impedance Settaluri et al. [2015] allowing for improved performance. In a flip-chip solution, the IC die is flipped with C4 solder bumps or copper pillars used to attach to a traditional organic or ceramic package. However when access to the active side of the die is necessary, for example when using grating couplers, flip-chip bonding may not be possible. In such cases vertical integration is made possible by using TSVs/TOVs where a via is formed through the bulk silicon or oxide from the inner contact pad to a backside metal pad for C4 or copper pillar bonding Bogaerts et al. [2018].

An  $8 \times 8$  SiPh Flex-LIONS chip with 176 electrical pads is wire-bonded to a co-designed printed circuit board (PCB) for electrical fan-out [35]. Two lid-less 16-channel  $127\text{-}\mu\text{m}$ -pitch polarization-maintaining (PM) fiber arrays are attached to the input and output of the chip using index-matching UV epoxy. Flexible flat cable (FFC) connectors are surface-mounted on the PCB for a compact footprint.

A pluggable SiP MEMS switch array has been demonstrated with contact interposer and ceramic interposer in Hwang et al. [2018]. A  $128 \times 128$  MEMS switch with glass interposer and pitch reducing fiber array is demonstrated in Hwang et al. [2017b]. A flip chip packaging of a  $12 \times 12$  switch using via less ceramic interposer is reported in Hwang et al. [2017a]. A  $32 \times 32$  switch with thermo optic MZI and monolithic monitor photodiodes is wirebonded to a CBGA with 68 fiber ribbon in Dumais et al. [2017].

A  $32 \times 32$  switch with an extremely high- $\Delta$ -PLC connector is demonstrated in Suzuki et al. [2019]. A  $32 \times 32$  non duplicate polarization diversity switch is reported in Suzuki et al. [2020]. In this paper, authors report switch flip chip bonded to a ceramic interposer that converts 0.18 mm pitch electrodes with 0.5 mm Land Grid Array (LGA), and a 74 port  $127\ \mu\text{m}$  fiber array was attached to the chip.

A 3D integrated photonic and electronic chip using  $50\ \mu\text{m}$  copper pillar technology is reported in Testa et al. [2018].

An  $8 \times 8$  MZI based switch with a submount packaged with 16 narrow core fiber array with SMF on the other side and Spot Size Converter (SSC) on the chip is reported in Nakamura et al. [2016]. In the same work, authors also report transponder aggregators (TPAs) assembly with 12 co-packaged optical switch modules with current drivers for 1800 thermo optic heaters.

Hybrid packaging of SiP switches, electronic driver chip and SOA arrays flip chip attached to a silicon carrier is reported in Budd et al. [2015]. A 12-channel SMF ribbon to chip assembly performed using high-volume tooling with off the shelf components is reported in Lee and Dupuis [2018]. A fully integrated  $4 \times 4$  switch flip chip integrated with a CMOS driver IC is reported in Rylyakov et al. [2011]. A broadband  $2 \times 2$  MZI switch is wirebonded to an electronic asic in Lee et al. [2013]. An FPGA embeded system with 16 high speed DAC/ADC and a packaged  $4 \times 4$  silicon benes switch is reported in Huang et al. [2017]. A  $2 \times 2$  Mach-Zehnder interferometer (MZI)-based switch element (SE) with active feedback power equalization fabricated in a wafer-scale hybrid silicon process is reported in Chen et al. [2013].

65 nm transistor bulk silicon CMOS technology with a layer of poly-crystalline silicon for photonic devices in a 300 millimeter wafer microelectronics foundry is reported in Atabaki et al. [2018]. A zero change process in 32 nm and 45 nm SOI CMOS with both transistors and photonic devices is reported in Stojanović et al. [2018]. A process in which SOI wafer is oxide bonded face-to-face with the CMOS wafer with Through oxide vias with 3fF parasitic capacitance up to 10x lower than that of micro-bump/copper pillar connection is reported in Stojanović et al. [2015]. A  $4 \times 4$  switch with IBM's 90nm photonics-enabled CMOS process is reported in Dupuis [2016].

## 5 Wavelength locking and stabilization

Switching elements used in WSS are sensitive to temperature variation and also have to be operated very close to servers in datacenters. Various wavelength locking and stabilization techniques have been reported for MRRs. A feedback

control mechanism, based on ContactLess Integrated Photonic Probes and heater actuators, is used to monitor and lock each device in real-time in Zanetto et al. [2020]. For multi-wavelength selective crossbar switches, a locking technique which uses heaters in monitor partial power drop ring resonators for calibration is reported in Khope et al. [2017a,b]. In the paper, authors lock two wavelength channels simultaneously from 20 – 40°C. Hitless tuning of MRR using a novel channel labelling scheme is reported in Aguiar et al. [2018]. A demonstration of locking with photoconductive heaters is reported in Jayatilleka et al. [2019]. Locking of three rings with a single monitor signal over a temperature range of > 40°C at 3x20 Gb/s OOK modulation and 3x75 Gb/s discrete multi-tone (DMT) modulation is reported in Dong et al. [2017]. An FPGA based tuning algorithm for WDM applications is reported in Gazman et al. [2017]. A wavelength stabilization scheme for silicon MRR with an in-resonator defect-state-absorption-based photodetector is reported in Li and Poon [2015]. A non invasive monitoring scheme using cmos integrated electronics is reported in Grillanda et al. [2014]. A locking scheme based dithering of heater voltage is reported in Padmaraju et al. [2013]. An automated wavelength alignment of a 5<sup>th</sup> order MRR with negligible passband ripples is reported in Mak et al. [2015]. Automatic calibration of 4x4 Benes is reported in siliconHuang et al. [2017].

## 6 Conclusion

We summarize the work done on integrated photonic WSS and their applications in datacenters. Electronic and photonic integration has enabled bigger switches with more complicated control circuits. Currently number of ports and number of wavelengths supported are limited by the size of electrical pads. With improvements in packaging technology and fabrication processes, we envision WSS with higher port counts.

## References

- Edward B Craft and John N Reynolds. Multiple-brush selector., January 5 1915. US Patent 1,123,695.
- Charles Clos. A study of non-blocking switching networks. *Bell System Technical Journal*, 32(2):406–424, 1953.
- Václav E Beneš. *Mathematical theory of connecting networks and telephone traffic*. Academic press, 1965.
- Xiaoxue Zhao, Bikash Koley, and Amin Vahdat. Dynamic data center network with a mesh of wavelength selective switches, November 8 2016. US Patent 9,491,526.
- Adel AM Saleh, Akhilesh SP Khope, John E Bowers, and Rod C Alferness. Elastic wdm switching for scalable data center and hpc interconnect networks. In *2016 21st OptoElectronics and Communications Conference (OECC) held jointly with 2016 International Conference on Photonics in Switching (PS)*, pages 1–3. IEEE, 2016.
- Bey-Chi Lin and Chin-Tau Lea. Construction of nonblocking wavelength/space switches with awgs and wsses. *Applied Sciences*, 7(6):555, 2017.
- Yifan Huang and Chin-Tau Lea. A new wss-based optical network architecture for data center networks. In *2016 Photonics North (PN)*, pages 1–1. IEEE, 2016.
- Lin Xu, Wenjia Zhang, Hugo LR Lira, Michal Lipson, and Keren Bergman. A hybrid optical packet and wavelength selective switching platform for high-performance data center networks. *Optics Express*, 19(24):24258–24267, 2011.
- Xuwei Xue, Fumi Nakamura, Kristif Prifti, Bitao Pan, Fulong Yan, Fu Wang, Xiaotao Guo, Hiroyuki Tsuda, and Nicola Calabretta. Sdn enabled flexible optical data center network with dynamic bandwidth allocation based on photonic integrated wavelength selective switch. *Optics Express*, 28(6):8949–8958, 2020.
- Francesco Testa, Stefano Tondini, Fabrizio Gambini, Philippe Velha, Alberto Bianchi, Christophe Kopp, Michael Hofbauer, Costanza Lucia Manganelli, Nikola Zecevic, Stefano Faralli, et al. Integrated reconfigurable silicon photonics switch matrix in iris project: Technological achievements and experimental results. *Journal of Lightwave Technology*, 37(2):345–355, 2018.
- Akhilesh SP Khope, Mitra Saeidi, Raymond Yu, Xinru Wu, Andrew M Netherton, Yuan Liu, Zeyu Zhang, Yujie Xia, Garey Fleeman, Alexander Spott, et al. Multi-wavelength selective crossbar switch. *Optics express*, 27(4):5203–5216, 2019.
- R Stabile, A Rohit, and KA Williams. Monolithically integrated 8 × 8 space and wavelength selective cross-connect. *Journal of Lightwave Technology*, 32(2):201–207, 2013.
- Xian Xiao, Roberto Proietti, Sebastian Werner, Pouya Fotouhi, and SJ Ben Yoo. Flex-lions: A scalable silicon photonic bandwidth-reconfigurable optical switch fabric. pages 1–3, 2019.
- Francesco Testa, Claudio J Oton, Christophe Kopp, Jong-Moo Lee, Ruben Ortuno, Reinhard Enne, Stefano Tondini, Guido Chiaretti, Alberto Bianchi, Paolo Pintus, et al. Design and implementation of an integrated reconfigurable silicon photonics switch matrix in iris project. *IEEE Journal of Selected Topics in Quantum Electronics*, 22(6): 155–168, 2016.

- Tae Joon Seok, Jianheng Luo, Zhilei Huang, Kyungmok Kwon, Johannes Henriksson, John Jacobs, Lane Ochikubo, Richard S Muller, and Ming C Wu. Silicon photonic wavelength cross-connect with integrated mems switching. *APL Photonics*, 4(10):100803, 2019.
- Qixiang Cheng, Meisam Bahadori, Madeleine Glick, Sébastien Rumley, and Keren Bergman. Recent advances in optical technologies for data centers: a review. *Optica*, 5(11):1354–1370, 2018a.
- Benjamin G Lee. Silicon photonic switching: Technology and architecture. In *2017 European Conference on Optical Communication (ECOC)*, pages 1–3. IEEE, 2017.
- Yiwen Shen, Xiang Meng, Qixiang Cheng, Sébastien Rumley, Nathan Abrams, Alexander Gazman, Evgeny Manzhosov, Madeleine Strom Glick, and Keren Bergman. Silicon photonics for extreme scale systems. *Journal of Lightwave Technology*, 37(2):245–259, 2019.
- Qixiang Cheng, Sébastien Rumley, Meisam Bahadori, and Keren Bergman. Photonic switching in high performance datacenters. *Optics express*, 26(12):16022–16043, 2018b.
- Richard E Wagner, Rod C Alferness, AAM Saleh, and Matthew S Goodman. Monet: Multiwavelength optical networking. *Journal of Lightwave Technology*, 14(6):1349–1355, 1996.
- Akhilesh SP Khope, Takako Hirokawa, Andrew M Netherton, Mitra Saeidi, Yujie Xia, Nicolas Volet, Clint Schow, Roger Helkey, Luke Theogarajan, Adel AM Saleh, et al. On-chip wavelength locking for photonic switches. *Optics letters*, 42(23):4934–4937, 2017a.
- Akhilesh SP Khope, Adel AM Saleh, John E Bowers, and Rod C Alferness. Elastic wdm crossbar switch for data centers. In *2016 IEEE Optical Interconnects Conference (OI)*, pages 48–49. IEEE, 2016.
- X. Xiao, R. Proietti, G. Liu, H. Lu, Y. Zhang, and S. J. B. Yoo. Multi-fsr silicon photonic flex-lions module for bandwidth-reconfigurable all-to-all optical interconnects. *Journal of Lightwave Technology*, 38(12):3200–3208, 2020.
- Yuta Goebuchi, Masahiko Hisada, Tomoyuki Kato, and Yasuo Kokubun. Optical cross-connect circuit using hitless wavelength selective switch. *Optics express*, 16(2):535–548, 2008.
- Tae Joon Seok, Jianheng Luo, Zhilei Huang, Kyungmok Kwon, Johannes Henriksson, John Jacobs, Lane Ochikubo, Richard S Muller, and Ming C Wu. Mem-actuated  $8 \times 8$  silicon photonic wavelength-selective switches with 8 wavelength channels. In *2018 Conference on Lasers and Electro-Optics (CLEO)*, pages 1–2. IEEE, 2018.
- Hao Yang, Qixiang Cheng, Rui Chen, and Keren Bergman. Polarization-diversity microring-based optical switch fabric in a switch-and-select architecture. pages Th3B–2, 2020.
- Zhan Su, Erman Timurdogan, Michele Moresco, Gerald Leake, Douglas D Coolbaugh, and Michael R Watts. Wavelength routing and multicasting network in ring-based integrated photonics. In *Integrated Photonics Research, Silicon and Nanophotonics*, pages IT4A–3. Optical Society of America, 2015.
- Kazuhiro Ikeda, Keiji Suzuki, Ryotaro Konoike, and Hitoshi Kawashima. Silicon photonics wavelength selective switch with unlimited free spectral range. *Journal of Lightwave Technology*, 2020.
- Akhilesh SP Khope, Roger Helkey, Songtao Liu, Sairaj Khope, Rod C Alferness, Adel AM Saleh, and John E Bowers. Scalable multicast hybrid broadband-crossbar wavelength selective switch: proposal and analysis. *Optics Letters*, 46(2):448–451, 2021a.
- Akhilesh S. P. Khope, Roger Helkey, Songtao Liu, Adel A. M. Saleh, Rod C. Alferness, and John E. Bowers. A scalable multicast hybrid broadband crossbar wavelength selective switch for datacenters. In *2021 IEEE 11th Annual Computing and Communication Workshop and Conference (CCWC)*, pages 1585–1587, 2021b. doi:10.1109/CCWC51732.2021.9376020.
- Akhilesh S.P. Khope, Songtao Liu, Andy Netherton, Zeyu Zhang, Sairaj Khope, Roger Helkey, Adel A.M. Saleh, Rod C. Alferness, and John E. Bowers. Experiments on multiwavelength selective crossbar switches. In *2020 International Conference on Information Science and Communications Technologies (ICISCT)*, pages 1–5, 2020. doi:10.1109/ICISCT50599.2020.9351493.
- Yishen Huang, Qixiang Cheng, Anthony Rizzo, and Keren Bergman. Push—pull microring-assisted space-and-wavelength selective switch. *Optics Letters*, 45(10):2696–2699, 2020.
- Jiayang Wu, Pan Cao, Ting Pan, Yuxing Yang, Ciyuan Qiu, Christine Tremblay, and Yikai Su. Compact on-chip  $1 \times 2$  wavelength selective switch based on silicon microring resonator with nested pairs of subrings. *Photonics Research*, 3(1):9–14, 2015.
- Fumi Nakamura, Kyosuke Muramatsu, Keiji Suzuki, Ken Tanizawa, Minoru Ohtsuka, Nobuyuki Yokoyama, Kazuyuki Matsumaro, Miyoshi Seki, Keiji Koshino, Kazuhiro Ikeda, Shu Namiki, Hitoshi Kawashima, and Hiroyuki Tsuda.



- Integrated silicon photonic wavelength-selective switch using wavefront control waveguides. *Opt. Express*, 26(10):13573–13589, May 2018a. doi:10.1364/OE.26.013573. URL <http://www.opticsexpress.org/abstract.cfm?URI=oe-26-10-13573>.
- Kengo Miura, Yuya Shoji, and Tetsuya Mizumoto. Silicon waveguide wavelength-selective switch for on-chip wdm communications. In *IEEE Photonics Conference 2012*, pages 630–631. IEEE, 2012.
- Fumi Nakamura, Hideaki Asakura, Keijiro Suzuki, Ken Tanizawa, Minoru Ohtsuka, Nobuyuki Yokoyama, Kazuyuki Matsumaro, Miyoshi Seki, Keiji Koshino, Kazuhiro Ikeda, et al. Silicon photonics based  $1 \times 2$  wavelength selective switch using fold-back arrayed-waveguide gratings. *IEICE Electronics Express*, 15(14):20180532–20180532, 2018b.
- CR Doerr, LL Buhl, L Chen, and N Dupuis. Monolithic gridless  $1 \times 2$  wavelength-selective switch in silicon. In *Optical Fiber Communication Conference*, page PDPC4. Optical Society of America, 2011.
- Hideaki Asakura, Takemasa Yoshida, Hiroyuki Tsuda, Keijiro Suzuki, Ken Tanizawa, Munehiro Toyama, Minoru Ohtsuka, Nobuyuki Yokoyama, Kazuyuki Matsumaro, Miyoshi Seki, et al. A 200-ghz spacing, 17-channel,  $1 \times 2$  wavelength selective switch using a silicon arrayed-waveguide grating with loopback. In *2015 International Conference on Photonics in Switching (PS)*, pages 52–54. IEEE, 2015.
- Pengjun Wang, Tianjun Yang, Tingge Dai, Gencheng Wang, Jie Zhang, Weiwei Chen, and Jianyi Yang. Design of a flexible-grid  $1 \times 2$  wavelength-selective switch using silicon microring resonators. *IEEE Photonics Journal*, 9(6):1–10, 2017.
- Hugo LR Lira, Sasikanth Manipatruni, and Michal Lipson. Broadband hitless silicon electro-optic switch for on-chip optical networks. *Optics Express*, 17(25):22271–22280, 2009.
- Qi Li, Dessislava Nikolova, David M Calhoun, Yang Liu, Ran Ding, Tom Baehr-Jones, Michael Hochberg, and Keren Bergman. Single microring-based  $2 \times 2$  silicon photonic crossbar switches. *IEEE Photonics Technology Letters*, 27(18):1981–1984, 2015.
- Philippe Velha, Isabella Cerutti, Odile Liboiron-Ladouceur, and Nicola Andriolli. A silicon photonics network-on-chip architecture based on mode and wavelength switching. In *2015 IEEE 12th International Conference on Group IV Photonics (GFP)*, pages 120–121. IEEE, 2015.
- Benjamin G Lee, Aleksandr Biberman, Nicolás Sherwood-Droz, Carl B Poitras, Michal Lipson, and Keren Bergman. High-speed  $2 \times 2$  switch for multiwavelength silicon-photonic networks-on-chip. *Journal of Lightwave Technology*, 27(14):2900–2907, 2009.
- Benjamin G Lee, Aleksandr Biberman, Nicolás Sherwood-Droz, Carl B Poitras, Michal Lipson, and Keren Bergman. High-speed  $2 \times 2$  switch for multi-wavelength message routing in on-chip silicon photonic networks. In *2008 34th European Conference on Optical Communication*, pages 1–2. IEEE, 2008.
- Andrew W Poon, Fang Xu, and Xianshu Luo. Cascaded active silicon microresonator array cross-connect circuits for wdm networks-on-chip. In *Silicon Photonics III*, volume 6898, page 689812. International Society for Optics and Photonics, 2008.
- Runxiang Yu, Stanley Cheung, Yuliang Li, Katsunari Okamoto, Roberto Proietti, Yawei Yin, and SJB Yoo. A scalable silicon photonic chip-scale optical switch for high performance computing systems. *Optics Express*, 21(26):32655–32667, 2013.
- Daryl M Beggs, Thomas P White, Liam O’Faolain, and Thomas F Krauss. Ultracompact and low-power optical switch based on silicon photonic crystals. *Optics letters*, 33(2):147–149, 2008.
- Huanying Zhou, Ciyuan Qiu, Xinhong Jiang, Qingming Zhu, Yu He, Yong Zhang, Yikai Su, and Richard Soref. Compact, submilliwatt,  $2 \times 2$  silicon thermo-optic switch based on photonic crystal nanobeam cavities. *Photonics Research*, 5(2):108–112, 2017.
- Changping Zhang, Ming Zhang, Yiwei Xie, Yaocheng Shi, Rajesh Kumar, Roberto R Panepucci, and Daoxin Dai. Wavelength-selective  $2 \times 2$  optical switch based on a ge 2 sb 2 te 5-assisted microring. *Photonics Research*, 8(7):1171–1176, 2020.
- Qixiang Cheng, Meisam Bahadori, Madeleine Glick, and Keren Bergman. Scalable space-and-wavelength selective switch architecture using microring resonators. In *2019 Conference on Lasers and Electro-Optics (CLEO)*, pages 1–2. IEEE, 2019.
- Kristif Prifti, Netsanet Tessema, Ripalta Stabile, and Nicola Calabretta. Performance assessment of a nanoseconds and modular photonic integrated wavelength selective switch for optical data centre networks. In *2018 Photonics in Switching and Computing (PSC)*, pages 1–3. IEEE, 2018.

- Ryotaro Konoike, Keiji Suzuki, Takashi Inoue, Takeshi Matsumoto, Teruo Kurahashi, Ayahito Uetake, Kazumasa Takabayashi, Suguru Akiyama, Shigeaki Sekiguchi, Shu Namiki, et al. Soa-integrated silicon photonics switch and its lossless multistage transmission of high-capacity wdm signals. *Journal of Lightwave Technology*, 37(1):123–130, 2018.
- Douwe Geuzebroek, Edwin Klein, Henry Kelderman, Nigel Baker, and Alfred Driessen. Compact wavelength-selective switch for gigabit filtering in access networks. *IEEE photonics technology letters*, 17(2):336–338, 2005.
- How Yuan Hwang, Jun Su Lee, Tae Joon Seok, Alex Forencich, Hannah R Grant, Dylan Knutson, Niels Quack, Sangyoon Han, Richard S Muller, George C Papen, et al. Flip chip packaging of digital silicon photonics mems switch for cloud computing and data centre. *IEEE Photonics Journal*, 9(3):1–10, 2017a.
- Patrick Dumais, Dominic J Goodwill, Dritan Celo, Jia Jiang, Chunshu Zhang, Fei Zhao, Xin Tu, Chunhui Zhang, Shengyong Yan, Jifang He, et al. Silicon photonic switch subsystem with 900 monolithically integrated calibration photodiodes and 64-fiber package. *Journal of Lightwave Technology*, 36(2):233–238, 2017.
- Keiji Suzuki, Ryotaro Konoike, Junichi Hasegawa, Satoshi Suda, Hiroyuki Matsuura, Kazuhiro Ikeda, Shu Namiki, and Hitoshi Kawashima. Low-insertion-loss and power-efficient  $32 \times 32$  silicon photonics switch with extremely high- $\delta$  silica plc connector. *Journal of Lightwave Technology*, 37(1):116–122, 2019.
- Shigeru Nakamura, Shigeoyuki Yanagimachi, Hitoshi Takeshita, Akio Tajima, Tomoyuki Hino, and Kiyoshi Fukuchi. Optical switches based on silicon photonics for roadm application. *IEEE Journal of Selected Topics in Quantum Electronics*, 22(6):185–193, 2016.
- Benjamin G Lee, Alexander V Rylyakov, William MJ Green, Solomon Assefa, Christian W Baks, Renato Rimolo-Donadio, Daniel M Kuchta, Marwan H Khater, Tymon Barwicz, Carol Reinholm, et al. Monolithic silicon integration of scaled photonic switch fabrics, cmos logic, and device driver circuits. *Journal of Lightwave Technology*, 32(4):743–751, 2013.
- Alexander V Rylyakov, Clint L Schow, Benjamin G Lee, William MJ Green, Solomon Assefa, Fuad E Doany, Min Yang, Joris Van Campenhout, Christopher V Jahnes, Jeffrey A Kash, et al. Silicon photonic switches hybrid-integrated with cmos drivers. *IEEE Journal of Solid-State Circuits*, 47(1):345–354, 2011.
- Luis Chen, Avantika Sohdi, John E Bowers, Luke Theogarajan, Jon Roth, and Greg Fish. Electronic and photonic integrated circuits for fast data center optical circuit switches. *IEEE Communications Magazine*, 51(9):53–59, 2013.
- How Yuan Hwang, Jun Su Lee, Johannes Henriksson, Kyungmok Kwon, Tae Joon Seok, Ming C Wu, and Peter O’Brien. Pluggable silicon photonic mems switch package for data centre. In *2018 IEEE 20th Electronics Packaging Technology Conference (EPTC)*, pages 46–49. IEEE, 2018.
- Amir H Atabaki, Sajjad Moazeni, Fabio Pavanello, Hayk Gevorgyan, Jelena Notaros, Luca Alloatti, Mark T Wade, Chen Sun, Seth A Kruger, Huaiyu Meng, et al. Integrating photonics with silicon nanoelectronics for the next generation of systems on a chip. *Nature*, 556(7701):349–354, 2018.
- Krishna T. Settaluri, Sen Lin, Sajjad Moazeni, Erman Timurdogan, Chen Sun, Michele Moresco, Zhan Su, Yu-Hsin Chen, Gerald Leake, Douglas LaTulipe, Colin McDonough, Jeremiah Hebding, Douglas Coolbaugh, Michael Watts, and Vladimir Stojanović. Demonstration of an optical chip-to-chip link in a 3d integrated electronic-photonic platform. In *ESSCIRC Conference 2015 - 41st European Solid-State Circuits Conference (ESSCIRC)*, pages 156–159, 2015. doi:10.1109/ESSCIRC.2015.7313852.
- V Stojanović, KT Settaluri, S Lin, S Moazeni, E Timurdogan, C Sun, M Moresco, Z Su, YH Chen, G Leake, et al. High-density 3d electronic-photonic integration. In *2015 Fourth Berkeley Symposium on Energy Efficient Electronic Systems (E3S)*, pages 1–2. IEEE, 2015.
- Riccardo Marchetti, Cosimo Lacava, Ali Khokhar, Xia Chen, Ilaria Cristiani, David J. Richardson, Graham T. Reed, Periklis Petropoulos, and Paolo Minzioni. High-efficiency grating-couplers: demonstration of a new design strategy. *Scientific Reports*, 7(1):16670, Nov 2017.
- Shuting Kang, Ru Zhang, Zhenzhong Hao, Di Jia, Feng Gao, Fang Bo, Guoquan Zhang, and Jingjun Xu. High-efficiency chirped grating couplers on lithium niobate on insulator. *Opt. Lett.*, 45(24):6651–6654, Dec 2020.
- R. Takei, M. Suzuki, E. Omoda, S. Manako, T. Kamei, M. Mori, and Y. Sakakibara. Silicon knife-edge taper waveguide for ultralow-loss spot-size converter fabricated by photolithography. *Applied Physics Letters*, 102(10):101108, 2013. doi:10.1063/1.4795308. URL <https://doi.org/10.1063/1.4795308>.
- Roger Dangel, Jens Hofrichter, Folkert Horst, Daniel Jubin, Antonio La Porta, Norbert Meier, Ibrahim Murat Soganci, Jonas Weiss, and Bert Jan Offrein. Polymer waveguides for electro-optical integration in data centers and high-performance computers. *Opt. Express*, 23(4):4736–4750, Feb 2015. doi:10.1364/OE.23.004736. URL <http://www.opticsexpress.org/abstract.cfm?URI=oe-23-4-4736>.

- Patrick Dumais, Dominic J. Goodwill, Dritan Celo, Jia Jiang, Chunshu Zhang, Fei Zhao, Xin Tu, Chunhui Zhang, Shengyong Yan, Jifang He, Ming Li, Wanyuan Liu, Yuming Wei, Dongyu Geng, Hamid Mehrvar, and Eric Bernier. Silicon photonic switch subsystem with 900 monolithically integrated calibration photodiodes and 64-fiber package. *J. Lightwave Technol.*, 36(2):233–238, Jan 2018. URL <http://jlt.osa.org/abstract.cfm?URI=jlt-36-2-233>.
- L. Bogaerts, Z. El-Mekki, S. Van Huylenbroeck, P. Nolmans, N. Pantano, X. Sun, M. Rakowski, D. Velenis, P. Verheyen, S. Balakrishnan, P. De Heyn, B. Snyder, Y. Ban, S. Srinivasan, S. Lardenois, J. De Coster, M. Detalle, P. Absil, A. Miller, M. Pantouvaki, and J. Van Campenhout. High-speed tsv integration in an active silicon photonics interposer platform. In *2018 IEEE SOI-3D-Subthreshold Microelectronics Technology Unified Conference (S3S)*, pages 1–3, 2018. doi:10.1109/S3S.2018.8640164.
- How Yuan Hwang, Padraic Morrissey, Jun Su Lee, Peter O’Brien, Johannes Henriksson, Ming C Wu, and Tae Joon Seok.  $128 \times 128$  silicon photonic mems switch package using glass interposer and pitch reducing fibre array. In *2017 IEEE 19th Electronics Packaging Technology Conference (EPTC)*, pages 1–4. IEEE, 2017b.
- Keijiro Suzuki, Ryotaro Konoike, Nobuyuki Yokoyama, Miyoshi Seki, Minoru Ohtsuka, Shigeru Saitoh, Satoshi Suda, Hiroyuki Matsuura, Koji Yamada, Shu Namiki, et al. Nonduplicate polarization-diversity  $32 \times 32$  silicon photonics switch based on a sin/si double-layer platform. *Journal of Lightwave Technology*, 38(2):226–232, 2020.
- Russell A Budd, Laurent Schares, Benjamin G Lee, Fuad E Doany, Christian Baks, Daniel M Kuchta, Clint L Schow, and Frank Libsch. Semiconductor optical amplifier (soa) packaging for scalable and gain-integrated silicon photonic switching platforms. In *2015 IEEE 65th Electronic Components and Technology Conference (ECTC)*, pages 1280–1286. IEEE, 2015.
- Benjamin G Lee and Nicolas Dupuis. Silicon photonic switch fabrics: Technology and architecture. *Journal of Lightwave Technology*, 37(1):6–20, 2018.
- Yishen Huang, Qixiang Cheng, Nathan C Abrams, Ji Zhou, Sébastien Rumley, and Keren Bergman. Automated calibration and characterization for scalable integrated optical switch fabrics without built-in power monitors. In *2017 European Conference on Optical Communication (ECOC)*, pages 1–3. IEEE, 2017.
- Vladimir Stojanović, Rajeev J Ram, Milos Popović, Sen Lin, Sajjad Moazeni, Mark Wade, Chen Sun, Luca Alloatti, Amir Atabaki, Fabio Pavanello, et al. Monolithic silicon-photonic platforms in state-of-the-art cmos soi processes. *Optics express*, 26(10):13106–13121, 2018.
- Nicolas Dupuis. Cmos photonic nanosecond-scale switch fabrics. In *2016 Optical Fiber Communications Conference and Exhibition (OFC)*, pages 1–3. IEEE, 2016.
- Francesco Zanetto, Vittorio Grimaldi, Miltiadis Moralis-Pegios, Stelios Pitris, Konstantinos Fotiadis, Theonitsa Alexoudi, Emanuele Guglielmi, Douglas Oliveira Morais de Aguiar, Peter De Heyn, Yoojin Ban, et al. Wdm-based silicon photonic multi-socket interconnect architecture with automated wavelength and thermal drift compensation. *Journal of Lightwave Technology*, 2020.
- Akhilesh SP Khope, Andrew M Netherton, Takako Hirokawa, Nicolas Volet, Eric J Stanton, Clint Schow, Roger Helkey, Adel AM Saleh, John E Bowers, and Rod C Alferness. Elastic wdm optoelectronic crossbar switch with on-chip wavelength control. In *Photonics in Switching*, pages PTh1D–3. Optical Society of America, 2017b.
- Douglas Aguiar, Maziyar Milanizadeh, Emanuele Guglielmi, Francesco Zanetto, Ruiqiang Ji, Sujie Zhou, Yanbo Li, Xiaolu Song, Lewei Zhang, Marco Sampietro, et al. Automatic tuning of microring-based hitless reconfigurable add-drop filters. In *2018 Optical Fiber Communications Conference and Exposition (OFC)*, pages 1–3. IEEE, 2018.
- Hasitha Jayatilaka, Hossam Shoman, Lukas Chrostowski, and Sudip Shekhar. Photoconductive heaters enable control of large-scale silicon photonic ring resonator circuits. *Optica*, 6(1):84–91, 2019.
- Po Dong, Robert Gatdula, Kwangwoong Kim, Jeffrey H Sinsky, Argishti Melikyan, Young-Kai Chen, Guilhem De Valicourt, and Jeffrey Lee. Simultaneous wavelength locking of microring modulator array with a single monitoring signal. *Optics express*, 25(14):16040–16046, 2017.
- Alexander Gazman, Colm Browning, Ziyi Zhu, Liam R Barry, and Keren Bergman. Automated thermal stabilization of cascaded silicon photonic ring resonators for reconfigurable wdm applications. In *2017 European Conference on Optical Communication (ECOC)*, pages 1–3. IEEE, 2017.
- Yu Li and Andrew W Poon. Active resonance wavelength stabilization for silicon microring resonators with an in-resonator defect-state-absorption-based photodetector. *Optics express*, 23(1):360–372, 2015.
- Stefano Grillanda, Marco Carminati, Francesco Morichetti, Pietro Ciccarella, Andrea Annoni, Giorgio Ferrari, Michael Strain, Marc Sorel, Marco Sampietro, and Andrea Melloni. Non-invasive monitoring and control in silicon photonics using cmos integrated electronics. *Optica*, 1(3):129–136, 2014.

---

Kishore Padmaraju, Dylan F Logan, Takashi Shiraishi, Jason J Ackert, Andrew P Knights, and Keren Bergman. Wavelength locking and thermally stabilizing microring resonators using dithering signals. *Journal of Lightwave Technology*, 32(3):505–512, 2013.

Jason CC Mak, Wesley D Sacher, Tianyuan Xue, Jared C Mikkelsen, Zheng Yong, and Joyce KS Poon. Automatic resonance alignment of high-order microring filters. *IEEE Journal of Quantum Electronics*, 51(11):1–11, 2015.