

# Advances in Machine and Deep Learning for Modeling and Real-time Detection of Multi-Messenger Sources

E. A. Huerta\* and Zhizhen Zhao

**Abstract** We live in momentous times. The science community is empowered with an arsenal of cosmic messengers to study the Universe in unprecedented detail. Gravitational waves, electromagnetic waves, neutrinos and cosmic rays cover a wide range of wavelengths and time scales. Combining and processing these datasets that vary in volume, speed and dimensionality requires new modes of instrument coordination, funding and international collaboration with a specialized human and technological infrastructure. In tandem with the advent of large-scale scientific facilities, the last decade has experienced an unprecedented transformation in computing and signal processing algorithms. The combination of graphics processing units, deep learning, and the availability of open source, high-quality datasets, have powered the rise of artificial intelligence. This digital revolution now powers a multi-billion dollar industry, with far-reaching implications in technology and society. In this chapter we describe pioneering efforts to adapt artificial intelligence algorithms to address computational grand challenges in Multi-Messenger Astrophysics. We review the rapid evolution of these disruptive algorithms, from the first class of algorithms introduced in early 2017, to the sophisticated algorithms that now incorporate domain expertise in their architectural design and optimization schemes. We discuss the importance of scientific visualization and extreme-scale computing in reducing time-to-insight and obtaining new knowledge from the interplay between models and data.

---

E. A. Huerta

Argonne National Laboratory, Lemont, Illinois 60439, USA & University of Chicago, Chicago, Illinois 60637, USA & University of Illinois at Urbana-Champaign, Urbana, Illinois 61801, USA. e-mail: [elihu@anl.gov](mailto:elihu@anl.gov)

Zhizhen Zhao

Department of Electrical and Computer Engineering & Coordinated Science Laboratory & Department of Mathematics & Department of Statistics & National Center for Supercomputing Applications & Center for Artificial Intelligence Innovation, University of Illinois at Urbana-Champaign, Urbana, Illinois 61801, USA. e-mail: [zhizhenz@illinois.edu](mailto:zhizhenz@illinois.edu)

\* corresponding author

## Keywords

Multi-Messenger Astrophysics; Numerical Relativity; Gravitational Waves; Electromagnetic Surveys; Big Data; Deep Learning; Artificial Intelligence; Interpretable Artificial Intelligence; High Performance Computing; Real-time Inference

## Introduction

This chapter provides a summary of recent developments harnessing the data revolution to realize the science goals of Gravitational Wave Astrophysics. This is an exciting journey that is powered by the renaissance of artificial intelligence, and a new generation of researchers that are willing to embrace disruptive advances in innovative computing and signal processing tools.

In this chapter, machine learning refers to a class of algorithms that can learn from data to solve new problems without being explicitly re-programmed. While traditional machine learning algorithms, e.g., random forests, nearest neighbors, etc., have been used successfully in many applications, they are limited in their ability to process raw data, usually requiring time-consuming feature engineering to pre-process data into a suitable representation for each application. On the other hand, deep learning algorithms can learn patterns from unstructured data, finding useful representations and automatically extracting relevant features for each application. The ability of deep learning to deal with poorly defined abstractions and problems has led to major advances in image recognition, speech, computer vision applications, robotics, among others [1].

The following sections describe a few noteworthy applications of modern machine learning for gravitational wave modeling, detection and inference. It is the expectation that by the time this chapter is published, the ongoing developments at the interface of artificial intelligence and extreme-scale computing will have leapt forward, making this chapter a reminiscence of a fast-paced, evolving field of research. The chapter concludes with a summary of recent applications at the interface of deep learning and high performance computing to address computational grand challenges in Gravitational Wave Astrophysics.

### *Machine learning and numerical relativity for gravitational wave source modeling*

One of the first examples of gravitational wave source modeling was introduced by Einstein. He derived an approximated version of his field equations [2] to confirm that general relativity accurately predicts the precession of the perihelion of Mercury [3]. Shortly after Einstein published his general theory of relativity, Karl

Schwarzschild found an exact solution to Einstein’s field equations, known as the Schwarzschild metric [4]. This analytical solution describes the gravitational field outside of a spherical mass that has no charge and no spin, under the assumption that the cosmological constant is zero. Soon afterwards, Reissner and Nordström derived an analytical solution that describes the gravitational field exterior to a charged, non-spinning spherical mass [5]. Nearly five decades later, and with the understanding that these metrics describe the gravitational field outside black holes, Roy Kerr discovered the analytical solution that describes uncharged, spinning black holes [6]. Shortly thereafter, the Kerr metric was extended to the case of charged, spinning black holes—the Kerr-Newman metric [7].

While these analytical solutions provided tools to extract new insights from general relativity, there were astrophysical scenarios of interest that required novel approaches. The development of approximate solutions to Einstein’s equations, such as the post-Newtonian [8] and post-Minkowskian formalisms [9], provided a better understanding of gravitationally bound systems like neutron star mergers that were prime targets for gravitational wave detection. Still, a detailed study of gravitational wave emission in the strong, highly dynamical gravitational field of black hole mergers required a complete numerical solution of Einstein’s field equations. In the late 1990s, and after decades of mathematical and numerical developments, the Binary Black Hole Grand Challenge Alliance, funded by the US National Science Foundation, successfully simulated a head-on binary black hole collision [10]. The first successful evolution of binary black hole spacetimes, including calculations about the orbit, merger, and gravitational waves emitted, were reported in [11]. Afterwards, other numerical relativity teams reported similar accomplishments [12, 13].

Within a decade, numerical relativity matured to the point of harnessing high performance computing with mature software stacks to study the physics and gravitational wave emission of binary black hole mergers covering a wide range of astrophysical scenarios of interest [14–17]. These resources have been used extensively to develop semi-analytical waveform models that describe the inspiral-merger-ringdown of binary black hole mergers [18–20] and to inform the design of algorithms for gravitational wave detection [21].

In time, the need to produce accurate and computationally efficient waveform models became apparent. This need has led to the adoption of surrogate models [23–26] and traditional machine learning techniques, such as Gaussian emulation [22, 27]. The development of fast waveform generators has had a significant impact in gravitational wave parameter estimation studies. This is because Bayesian parameter estimation that utilizes Markov-chain Monte Carlo requires  $\mathcal{O}(10^8)$  waveform evaluations. Surrogate waveforms are tailored for this task, since each waveform may be produced within 50ms with typical mismatches of order  $10^{-3}$  with other state-of-the-art waveform approximants [23]. Figure 1 shows an example of a Gaussian emulator used to create a stand-alone merger waveform trained with a catalog of quasi-circular, non-spinning, binary black hole mergers. Notice how the performance of the emulator changes depending on the format with which the training dataset is presented to the emulator. This is a key difference between tra-

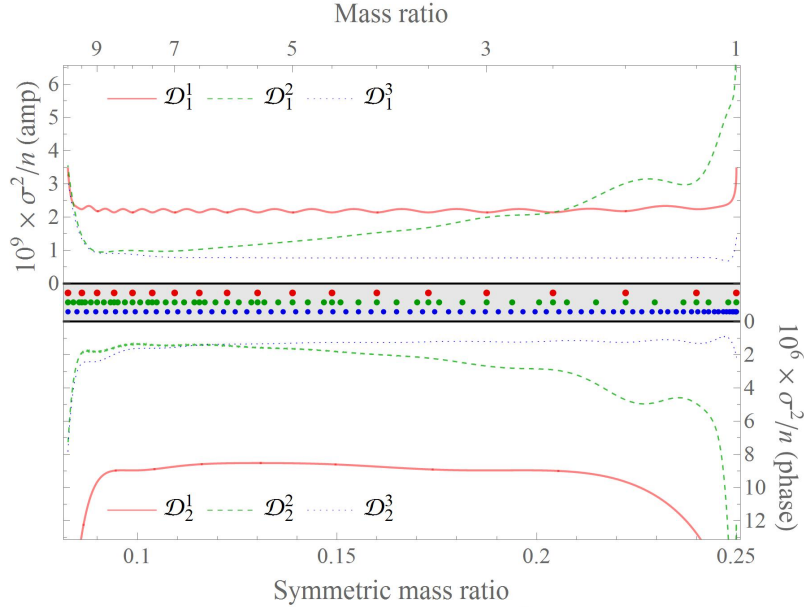

**Fig. 1** Interpolation error,  $\sigma$ , of a Gaussian Process Emulator on the amplitude (top panel), and phase (bottom panel), for three training datasets that describe quasi-circular, non-spinning binary black hole mergers:  $\mathcal{D}_\alpha^1$  (red),  $\mathcal{D}_\alpha^2$  (green), and  $\mathcal{D}_\alpha^3$  (blue). Each numerical relativity waveform in these sets has  $n = 2800$  time samples. The (symmetric) mass ratio values for the points in  $\mathcal{D}^1$ ,  $\mathcal{D}^2$  and  $\mathcal{D}^3$  are indicated respectively by red, green, and blue dots along the central horizontal panel. Each iteration of the training set reduces the error in the amplitude and phase interpolations. This Figure was produced by the authors of this chapter in the published article [22].

ditional machine learning and deep learning, since in the latter case, neural networks do not need feature engineering to provide optimal performance.

Large-scale numerical relativity waveform catalogs have also been used as datasets to train Gaussian emulators to produce highly accurate modeled waveforms in record time [22]. It is also known that traditional machine learning methods, such as surrogate models or Gaussian emulation, present several challenges when trying to organize data in high-dimensional spaces [28]. In stark contrast, deep neural networks excel at learning high-dimensional data and provide additional advantages such as improving convergence and performance when combined with extreme-scale computing.

While rapid progress has taken place in the modeling of binary black hole mergers, matter systems such as binary neutron star mergers and black hole-neutron star mergers continue to present significant challenges [29]. It is expected that numerical relativity will meet these challenges within the next few years with the production of open source numerical relativity software that will bring together experts across the community. The adoption of deep learning to accelerate the description of physics

that requires sub-grid scale precision, such as turbulence, is also in earnest development [30].

In summary, numerical relativity has played a key role in the development of waveform models and signal processing algorithms that enabled the discovery of gravitational waves. Numerical relativity and machine learning have combined to produce modeled waveforms for production-scale gravitational wave analyses. We also see a new trend in which numerical relativity and deep learning have been combined for waveform production at scale. This approach may well provide a solution for high-dimensional signal manifolds. Another exciting trend is the use of deep learning to replace compute-intensive modules in numerical relativity software that describes matter systems.

### *Machine learning for gravitational wave data analysis*

In this section we review machine learning applications in the context of parameter estimation, rapid characterization of compact binary remnants, and signal denoising. **Parameter Estimation** Machine learning applications for gravitational wave inference have been developed to overcome the computational expense and poor scalability of established Bayesian approaches. Estimating the posterior probability density functions of astrophysical parameters that describe gravitational wave sources is a computationally intensive task. This is because these systems span a 15-D parameter space, thereby requiring a large number of modeled waveforms to densely sample this signal manifold. In the previous section we discussed the importance of harnessing machine learning methods to produce modeled waveforms at scale. In addition to massive waveform generation, low to moderate signal-to-noise ratios and complex noise anomalies may require additional follow-up studies, thereby demanding additional computational resources. In order to mitigate these computational challenges, parameter estimation algorithms such as `LALInference` [31] and `PyCBC Inference` [32] use nested sampling [33] or Markov Chain Monte Carlo [34]. These techniques usually take days to weeks to produce posterior samples of gravitational wave sources' parameters. Thus, it is timely and relevant to explore new approaches to further reduce time-to-insight. This is ever more urgent as the international network of gravitational wave detectors continues to increase its sensitivity, thereby increasing the detection rate of observed events.

Machine learning solutions to accelerate parameter estimation include Gaussian process emulation [35], nested sampling [36], and nested sampling combined with neural networks [37]. In the latter case, likelihood calculations are accelerated by up to 100x for computationally demanding analyses that involve long signals, such as neutron star systems.

**Rapid characterization of compact binary remnants** Multi-Messenger searches demand real-time detection of gravitational wave sources, accurate sky localization, and information regarding the nature of the source, in particular whether the progenitor may be accompanied by electromagnetic or neutrino counterparts. To address

the latter point, i.e., to ascertain whether the remnant is a neutron star, or whether in the case of a neutron star-black hole merger the black hole remnant is surrounded by an accretion disk of tidally disrupted material from the neutron star, it may be possible to use information provided by low-latency detection algorithms. However, it is known that these estimates may differ from accurate but hours- to days-long parameter estimation studies. To start addressing these limitations, a supervised nearest neighbors classification method was introduced in [38]. This method infers, in a fraction of a second, whether a compact binary merger will have an electromagnetic counterpart, thus providing time-critical information to trigger statistically informed electromagnetic follow-up searches.

On the other hand, the ever-increasing catalog of detected gravitational wave sources provides the means to infer the mass and spin distributions of stellar mass compact binary systems. These studies will shed new light on the stellar evolution processes that may lead to the formation of these astrophysical objects, or whether these objects are formed from a mixture of different populations [39]. Agnostic studies that involve Gaussian mixture models are ideally suited to enable data-driven analyses [40].

**Signal denoising** Gravitational wave signals are contaminated by environmental and instrumental noise sources that are complex to model and difficult to remove. Several methods have been explored for data cleaning and noise subtraction, ranging from the basic Wiener filter that optimally removes linear noise [41] to machine learning applications that can effectively remove linear, non-linear, non-Gaussian and non-stationary noise contamination [42, 43]. Machine learning methods employed to remove noise from gravitational wave signals includes Bayesian methods [44], dictionary learning [45, 46], principal component analysis [47], and total-variational methods based on  $L_1$  norm minimization techniques that were originally developed in the context of image processing, but were subsequently adapted to clean signals in time- and frequency-domain [48].

This succinct summary of traditional machine learning applications in gravitational wave astrophysics suggests that part of this community has been engaged in harnessing advances in computing and signal processing to address computational grand challenges in this field. The following section shows how this process has been accelerated with the rise of artificial intelligence from the early 2010s.

### *Deep Learning for gravitational wave data analysis*

Gravitational wave data analysis encompasses a number of core tasks, including detection, parameter estimation, data cleaning, glitch classification and removal, and signal denoising. In this section we present a brief overview of the rapid rise of artificial intelligence for gravitational wave astrophysics.

**Detection** Existing algorithms for signal detection include template matching, where the physics of the source is used to inform the classification of noise triggers, and to identify those that describe gravitational wave sources [49, 50]. Other events

where the underlying astrophysics is unknown or too complex to capture in modeled waveforms take advantage of burst searches, which make minimal assumptions about the morphology of gravitational wave signals [51]. Continuous wave sources, such as isolated neutron stars, emit signals that, although well known, are very weak and long. This combination makes their search and detection very computationally intensive [52].

As mentioned above, as advanced LIGO and the international gravitational wave detector network gradually reach design sensitivity, core data analysis studies will outstrip the capabilities of existing computing facilities if we continue to use poorly scalable and compute-intensive signal processing methods. Furthermore, gravitational wave astrophysics is not the only discipline with an ever-increasing need for computing resources. The advent of other large-scale scientific facilities such as the Square Kilometer Array, the High Luminosity Large Hadron Collider, or the Legacy Survey of Space and Time, to mention a few [53–55], will produce datasets with ever-increasing complexity and volume. Thus, a radical approach in terms of computing and signal processing is needed to maximize and accelerate scientific discovery in the big data era.

To contend with these challenges, a disruptive approach that combines deep learning and high performance computing was introduced in [56]. This idea was developed to address a number of specific challenges. To begin with, the size of modeled waveform catalogs used for template matching searches imposes restrictions on the science reach of low-latency searches. Thus, it is worth exploring a different methodology that enables real-time gravitational wave detection without sacrificing the depth of the signal manifold that describes astrophysical sources. It turns out that there is indeed a signal processing tool, deep learning [57], that encapsulates information in a hierarchical manner, bypassing the need to use large catalogs of images or time-series for accelerated inference. The second key consideration in the use of deep learning for gravitational wave detection is the fact that real signals may be located anywhere in the data stream broadcast by detectors. Thus, the neural networks in [56, 58] introduced the concept of time-invariance. A third consideration is that there is no way to predict the signal-to-noise ratio of real events. Thus, the methods presented in [56, 58] showed how to adapt curriculum learning [59], originally developed in the context of image processing, to do classification or detection of noisy and weak signals. The key idea behind this approach consists of training the model by first exposing it to signals with high signal-to-noise ratio, and then gradually increasing the noise content until the signals become noise-dominated. The combination of the aforementioned innovations led to the realization that neural networks could indeed detect modeled gravitational wave signals embedded in simulated advanced LIGO noise with the same sensitivity as template matching algorithms, but orders of magnitude faster with a single, inexpensive GPU. In addition to these results, the authors in [56] showed how to modify a neural network classifier and use transfer learning to construct a neural network predictor that provides real-time point-parameter estimation results for the masses of the binary components, mirroring a similar capability of established low-latency detection analyses. This seminal work was then extended to the case of real gravitational wave signals in advanced

LIGO noise [58]. About a year later, different teams reported similar classification results in the context of modeled signals in simulated LIGO noise [60].

A metric for the impact of the seminal ideas laid out in [56, 58] is given by the number of research teams across the world that have reproduced and extended these studies [60–67]. It is also worth mentioning, however, that while these studies demonstrated the scalability, computational efficiency and sensitivity of neural networks for gravitational wave detection, it is still essential to demonstrate the use of these signal processing tools for searches that span a high-dimensional signal manifold, and to apply them to process large datasets.

Deep learning has been applied to the detection of neutron star mergers [68–70], forecasting of neutron stars inspirals and neutron star-black hole mergers [71, 72], continuous wave sources [73–75], signals with complex morphology [61], and to accelerate waveform production [76, 77]. The rapid progress and maturity that these algorithms have achieved within just three years, at the time of writing this book, suggest that production-scale deep learning methods are on an accelerated track to become an integral part of gravitational wave discovery [78, 79].

**Signal Denoising** The first deep learning application for the removal of noise and noise anomalies for gravitational wave signal processing was introduced in [80]. This study described how to combine recurrent neural networks with denoising auto-encoders to clean up modeled waveforms embedded in real advanced LIGO noise. The different components of this Enhanced Deep Recurrent Denoising Auto-Encoder (EDRDAE) are shown in Figure 2. To provide optimal denoising performance for low signal-to-noise ratio signals, this model incorporated a signal amplifier layer, and was trained with curriculum learning. Another feature of this model is that while it was originally trained to denoise signals that describe quasi-circular, non-spinning black hole mergers, this model was able to generalize to signals that describe eccentric, non-spinning black hole mergers, whose morphology is much more complex than the training dataset. This study showed that deep learning approaches outperform traditional machine learning methods such as principal component analysis and dictionary learning for gravitational wave signal denoising [80]. The first application of deep learning for signal denoising and de-glitching of actual gravitational wave observations was introduced in [81]. The model proposed for this analyses consists of a repurposed `WaveNet` architecture—see left panel of Figure 3—which was originally developed for forecasting and human speech generation [82]. The data used to train this network consists of one-second-long time-series modeled waveforms, sampled at 8192Hz, that describe quasi-circular, non-spinning binary black hole mergers. Upon encoding time- and scale-invariance, this model was used to denoise several gravitational wave signals, as shown in the right panel of Figure 3, and to demonstrate its effectiveness at removing noise and glitches from simulated signals embedded in real advanced LIGO noise. This model was also used to denoise quasi-circular, spinning, precessing binary black hole mergers, furnishing evidence for the ability of the model to generalize to new types of signals that were not used in the training stage.

**Data cleaning** Recent developments for data cleaning include [83], in which deep learning is applied to gravitational wave detector data and data from on-site sensors



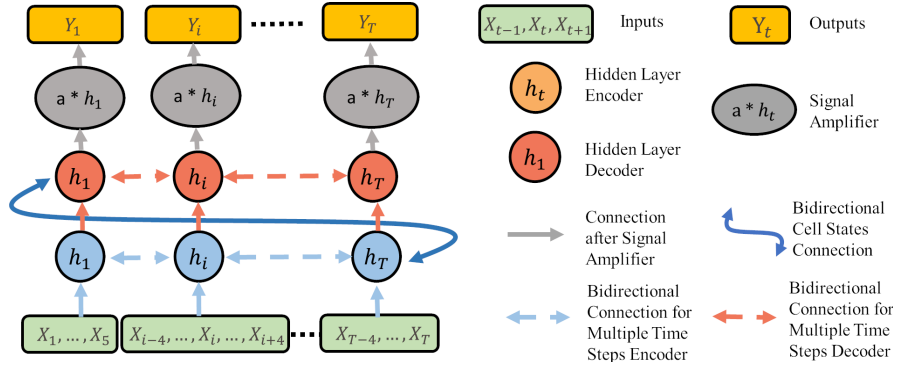

**Fig. 2** Architecture of the Enhanced Deep Recurrent Denoising Auto-Encoder model. Double arrows indicate the bidirectional long short-term memory (LSTM) connections. The one-directional arrows represent conventional LSTM structure and the solid blue double arrow connects cross layer cell states at the initial and the last steps in the time window. The last layer is the signal amplifier indicated by a gray ellipse. This Figure was produced by the authors of this chapter in the published article [80].

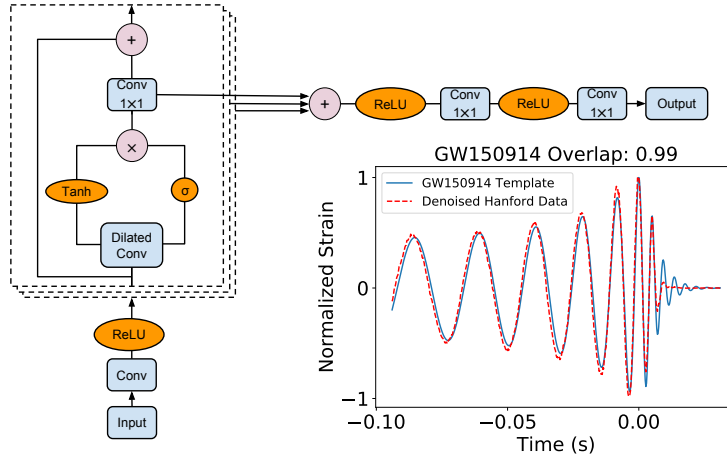

**Fig. 3** Left panel: architecture for the denoising WaveNet algorithm. Bottom-right panel: overlap between the output of the WaveNet denoising algorithm upon processing real advanced LIGO data that contains the event GW150914, and the template that best describes this astrophysical source according to matched-filtering algorithms. This Figure was produced by the authors of this chapter in the published article [81].

monitoring the instrument to reduce the noise in the time-series due to instrumental artifacts and environmental contamination. This approach is able to remove linear, nonlinear, and non-stationary coupling mechanisms, improving the signal-to-noise ratio of injected signals by up to  $\sim 20\%$ .

**Parameter Estimation** Uncertainty quantification is a rapidly evolving area in deep learning research. Thus, it is natural that a number of methodologies have been investigated to constrain the astrophysical parameters of gravitational wave sources. For instance, in [84], Bayesian neural networks were used to constrain the astrophysical properties of real gravitational wave sources before and after the merger event, showcasing the ability of neural networks to measure the final mass and spin remnant sources by directly processing real LIGO data. Conditional variational auto-encoders [85] and multivariate Gaussian posterior models [86] have been used to construct posterior distributions of modeled signals embedded in simulated LIGO noise. In [87], the authors introduce the use of auto-regressive normalizing flows for rapid likelihood-free inference of binary black hole mergers that describe an 8-D parameter space. This analysis, originally applied for modeled signals in stationary Gaussian noise, was extended to cover the 15-D parameter space for GW150914 [88]. Deep learning has also been explored to characterize compact binary populations [89].

***Deep Learning for the detection and characterization of higher-order waveform multipole signals of eccentric binary black hole mergers***

It has been argued in the literature that gravitational wave observations of eccentric binary black hole mergers will provide the cleanest evidence of the existence of compact binary populations in dense stellar environments, such as galactic nuclei and core-collapsed globular clusters [90].

The importance of including higher-order waveform modes for the detection of eccentric binary black hole mergers has been studied in the literature [91]. It has been found that, as in the case of quasi-circular mergers, higher-order modes play a significant role in the detection of asymmetric binary black hole mergers [92]. For instance, Figure 4 shows the increase in signal-to-noise ratio due to the inclusion of higher-order modes for a variety of astrophysical scenarios. These results show that for comparable mass ratio systems, represented by the numerical relativity waveform E0001 (see Table 1), higher-order modes do not alter the amplitude of the  $\ell = |m| = 2$  mode, thereby having a negligible contribution on the signal-to-noise ratio of these systems. However, for the asymmetric mass ratio systems represented by P0020 and P0024, the inclusion of higher-order modes leads to a significant increase in the signal-to-noise ratio of these systems.

In Figure 4 the signal-to-noise ratio distributions are presented as a function of the source's sky location,  $(\alpha, \beta)$ , mapped into a Mollweide projection:  $(\vartheta, \varphi) \rightarrow (\pi/2 - \alpha, \beta - \pi)$ . The reference frame  $(\theta, \phi)$  is anchored at the center of mass of the binary system, and determines the location of the detector. In this reference frame,  $\theta = 0$  coincides with the total angular momentum of the binary, and  $\phi$  indicates the azimuthal direction to the observer. Furthermore, the top panels in Figure 4 show that the inclusion of  $(\ell, |m|)$  modes significantly modifies the ringdown evolution of  $\ell = |m| = 2$  waveforms. The finding is in line with studies that indicate the need to

**Table 1** ( $q, e_0, \ell_0, x_0$ ) represent the mass ratio and the measured values of eccentricity, mean anomaly, and dimensionless orbital frequency parameters.

Simulation	$q$	$e_0$	$\ell_0$	$x_0$
E0001	1	0.052	3.0	0.0770
J0040	1	0.160	3.0	0.0761
L0016	5	0.140	2.9	0.0862
P0016	6	0.160	2.8	0.0900
P0020	8	0.180	2.9	0.0936
P0024	10	0.180	3.0	0.0957

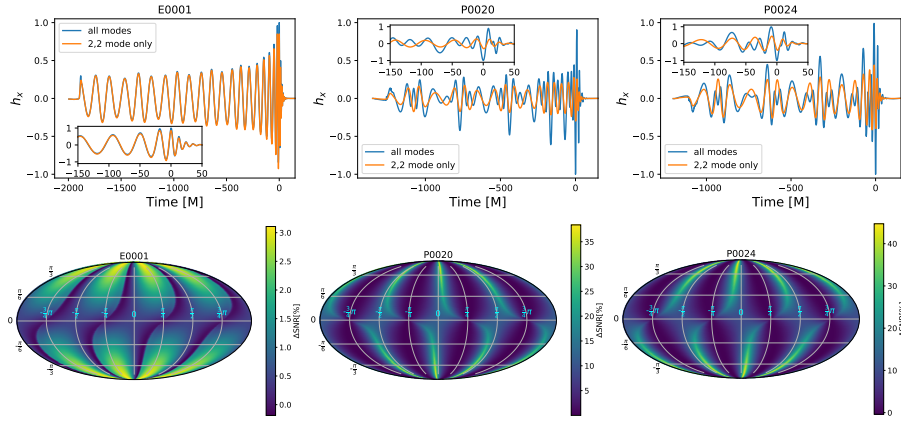
**Fig. 4** Top panels: comparison between numerical relativity waveforms that include either all  $(\ell, |m|)$  modes or the  $\ell = |m| = 2$  mode only, using  $(\theta, \phi)$  values that maximize the inclusion of higher-order modes in terms of signal-to-noise ratio calculations. Bottom panels: increase in signal-to-noise ratio,  $\Delta\text{SNR}$ , due to the inclusion of higher-order modes. These sky distributions are produced with the waveforms shown in the top panels. This Figure was produced by the authors of this chapter in the published article [91].

include  $(\ell, |m|)$  modes for tests of general relativity using ringdown waveforms [93, 94].

Having identified a collection of waveforms in which the inclusion of higher-order modes induce the most significant modification to the  $\ell = |m| = 2$  mode, corresponding to the maximum gain in signal-to-noise ratio, the authors in [91] injected these signals into simulated and real advanced LIGO noise, and used neural networks to search for them. Their findings are shown in Figure 5. In a nutshell, deep learning models can identify these complex signals, even though they were trained with quasi-circular waveforms. Future studies may explore whether neural networks improve their sensitivity when they are trained with datasets that describe eccentric mergers.

#### **Deep Learning for the characterization of spin-aligned binary black hole mergers**

Deep learning has been used to study the properties of the gravitational wave signal manifold that describes quasi-circular, spinning, non-precessing binary black

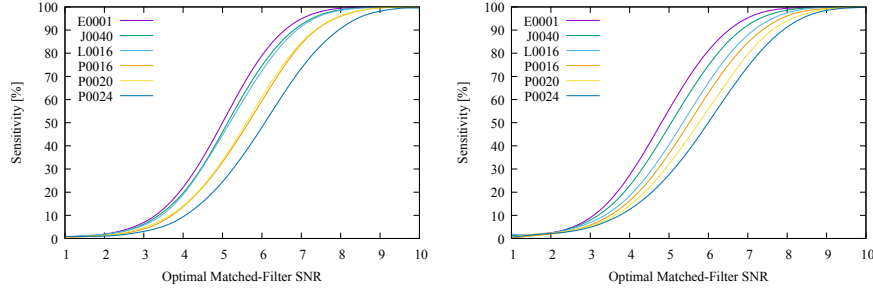

**Fig. 5** Left panel: neural networks may detect eccentric signals that include higher-order modes with optimal sensitivity in simulated Gaussian noise when their matched-filtering signal-to-noise ratio is  $\geq 10$ . Right panel: same as the left panel, but now using real advanced LIGO noise. This Figure was produced by the authors of this chapter in the published article [91].

hole mergers [95]. This study explored how neural networks handle parameter space degeneracies, and their ability to measure the individual spins, effective spin and mass ratio of black hole mergers by directly processing waveform signals in the absence of noise.

The model introduced in [95] was trained, validated and tested with  $\ell = |m| = 2$  waveforms produced with the NRHybSur3dq8 [96] surrogate model. These signals cover a time span  $t \in [-10, 000M, 130M]$  with a time step  $\Delta t = 0.1M$ . The training set is generated by sampling the mass ratio  $q \in [1, 8]$  in steps of  $\Delta q = 0.08$ ; and the individual spins  $s_i^z \in [-0.8, 0.8]$  in steps of  $\Delta s_i^z = 0.012$ . This is equivalent to  $\sim 1.5$  million waveforms. The validation and test sets are generated by alternately sampling the intermediate values, i.e. by sampling  $q$  and  $s_i^z$  in steps of 0.16 and 0.024 to lie between the training set values, for a total of  $\sim 190,000$  waveforms each, respectively. The distributions of parameters for training, validation and test sets is shown in Fig 6. The entire data set is  $\sim 1.5TB$  in size, and `mpi4py` is used to parallelize data generation.

**Neural network architecture** The neural network architecture consists of two fundamental components, a shared root consisting of layers slightly modified from the WaveNet [82] architecture, and two branches consisting of fully connected layers that take in features extracted from the root to predict the mass ratio and the individual spins of the binary components, respectively, as illustrated in Fig 7.

**Physics-inspired optimization scheme** The effective one-body Hamiltonian for moderately spinning black holes,

$$S_{\text{eff}} = \sigma_1 s_1^z + \sigma_2 s_2^z, \quad (1)$$

where  $\sigma_1 \equiv 1 + \frac{3}{4q}$  and  $\sigma_2 \equiv 1 + \frac{3q}{4}$ , and the effective spin parameter

$$\sigma_{\text{eff}} = \frac{m_1 s_1^z + m_2 s_2^z}{m_1 + m_2} = \frac{q s_1^z + s_2^z}{1 + q}, \quad (2)$$

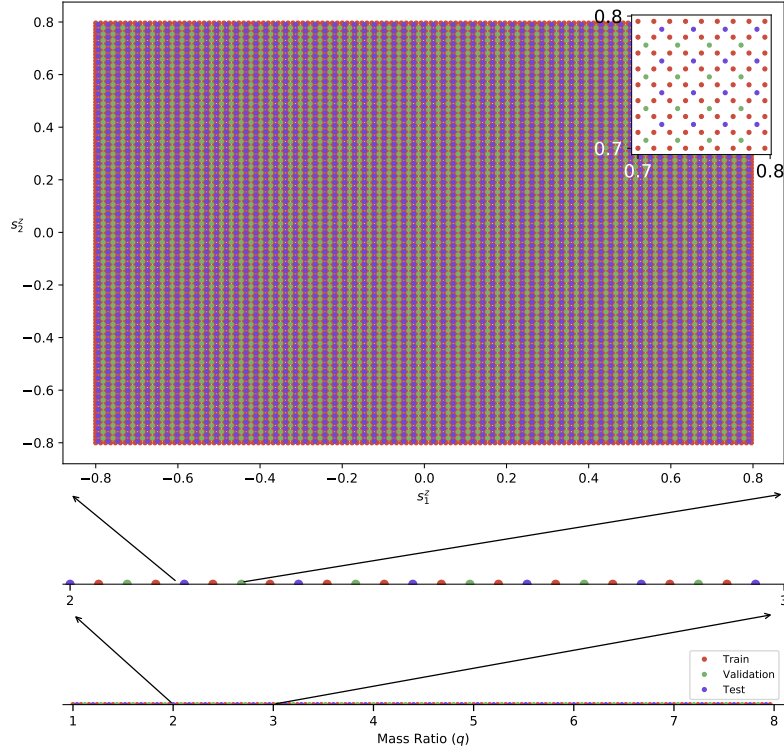

**Fig. 6** Sampling of the signal manifold  $q \in [1, 8]$ ,  $s_{\{1,2\}}^z \in [-0.8, 0.8]$  to construct the training (light blue dots), validation (dark blue dots) and testing (red dots) data sets. This Figure was produced by the authors of this chapter in the published article [95].

were used to train the model and provide tight constraints for the individual spins  $s_i^z$ . The performance of the neural network was assessed by computing the overlap  $\mathcal{O}(h, s)$ , between every waveform in the testing dataset,  $h(\theta^i)$  with ground-truth parameters  $\theta^i$ , and the signal,  $s$ , that best describes  $h$  according to the neural network model, i.e.,  $s(\hat{\theta}^i)$  using the relation

$$\mathcal{O}(h, s) = \max_{t_c, \phi_c} (\hat{h} | \hat{s}_{[t_c, \phi_c]}), \quad \text{with } \hat{h} = h(h|h)^{-1/2}. \quad (3)$$

Figure 8 indicates that deep learning accurately measures the mass ratio and individual spins over a broad range of the parameter space under consideration.

This study [95] has shown that while vanilla neural networks provide uninformative predictions for the astrophysical parameters of black hole mergers, physics-inspired models provide accurate predictions. Thus, these approaches may be investigated in the context of parameter estimation to further constrain existing measurements for the spin distribution of observed events.

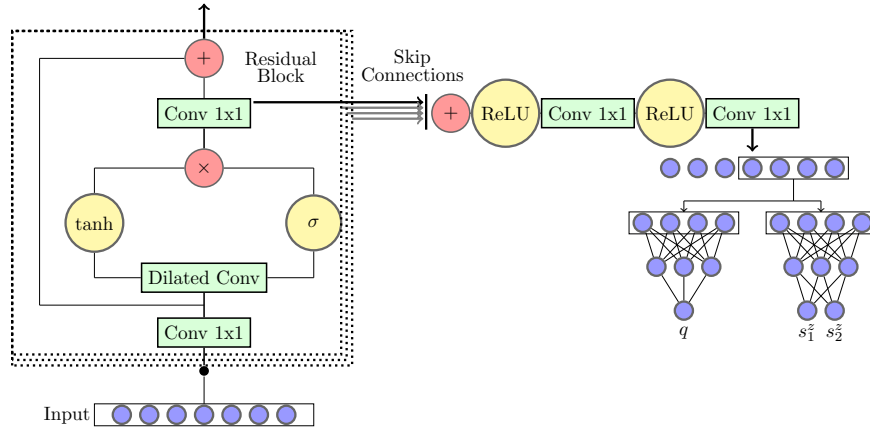

**Fig. 7** Physics-inspired neural network architecture. Residual blocks of Wavenet (left panel) and leaf layers (right panel). This Figure was produced by the authors of this chapter in the published article [95].

As in the case of gravitational wave detection, deep learning applications for inference are progressing at a very rapid pace. The extension of existing neural network models to characterize real signals with a broader range of reported signal-to-noise ratios, in particular at the low end, will mark a major milestone on this exciting front.

The importance of developing novel signal processing tools and computing approaches is underscored by the computing needs of established, though poorly scalable and compute-intensive algorithms, which burned about 500M CPU core-hours in astrophysical searches, follow up studies and detector characterization analyses during the third observing run. Furthermore, the second observing run indicates that about 10M CPU core-hours of computing were needed for  $\mathcal{O}(10)$  detected events. In the scenario of a third generation gravitational wave detection network with three interferometers, the number of observed events per year may be of order  $\mathcal{O}(10^3)$ , and thus the computing needs will grow by 3 orders of magnitude. In brief, it is essential to pursue innovation in signal processing tools, computing methodologies and hardware architectures if we are to realize the science goals of gravitational wave astrophysics [97].

### ***Deep Learning for the classification and clustering of noise anomalies in gravitational wave data***

While deep learning is now customarily used to extract information from complex, noisy, and heterogeneous datasets, it is worth exploring and removing known sources of noise from experimental datasets. This is particularly relevant in the con-

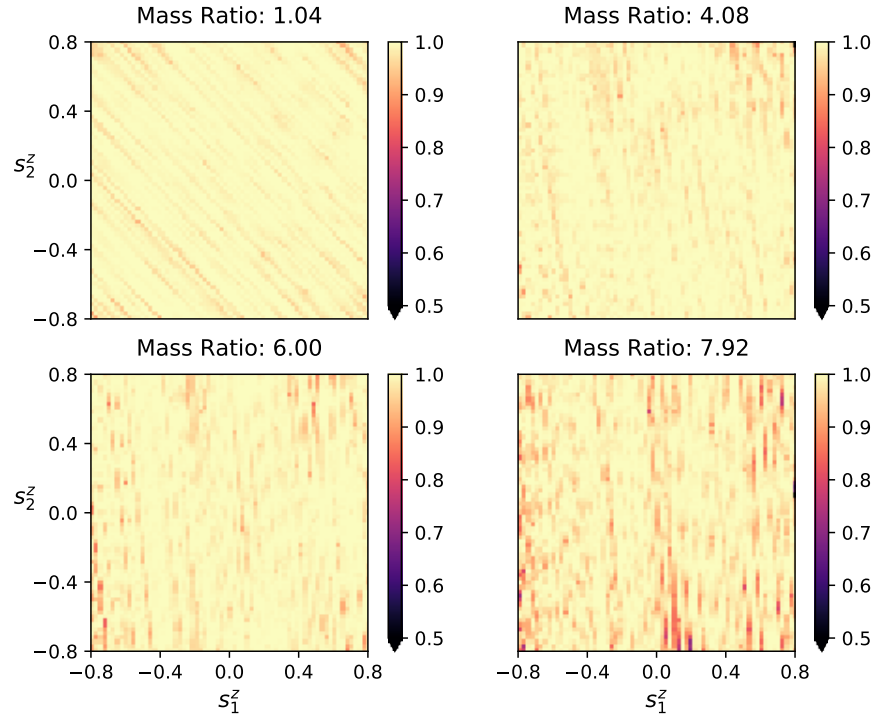
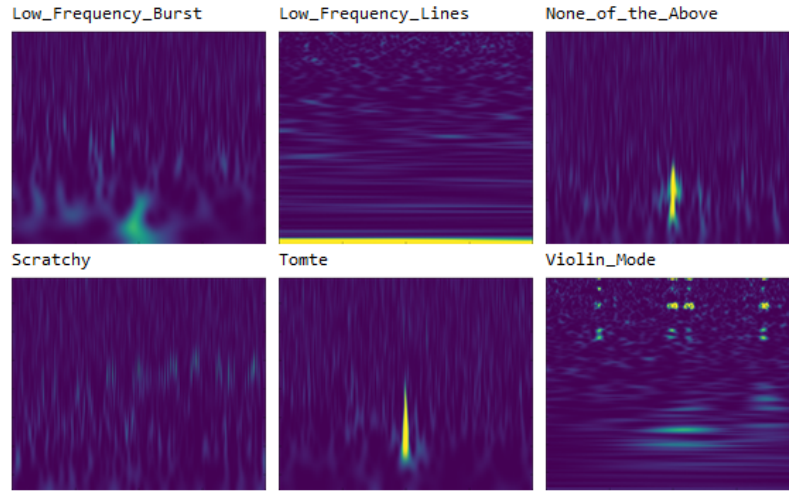

**Fig. 8** Each point in the top and middle panels represents the overlap between a signal in the testing data set and its counterpart whose individual spins and mass ratio are predicted by the neural network model. The mass ratio slices presented in this figure were randomly selected from the testing data set. This Figure was produced by the authors of this chapter in the published article [95].

text of gravitational wave astrophysics, since noise anomalies—or glitches—tend to contaminate and even mimic real gravitational wave signals.

The *Gravity Spy* project aims to identify, classify and excise instrumental and environmental sources of noise that decrease the sensitivity of ground-based gravitational wave detectors [98]. A sample of glitches classified by the *Gravity Spy* are shown in Figure 9.

As citizen science efforts continue to increase the number of glitches classified through *Gravity Spy*, it may be possible to automate their classification, or to utilize human-in-the-loop machine learning methods. An initial approach for glitch classification was presented in [98]. This method consisted of using the small and unbalanced dataset of *Gravity Spy* glitches to train a neural network model from the ground up. A method for automatic glitch classification was introduced in [99]. This approach combined deep learning with transfer learning for glitch classification. Specifically, this study showed that models such as *Inception*, *ResNet-50*, and *VGG* that have been pre-trained for real-object recognition using



**Fig. 9** Sample of glitches in the *Gravity Spy* dataset from advanced LIGO’s first observing run. This Figure was produced by the authors of this chapter in the published article [99].

ImageNet may be fine-tuned through transfer learning to enable optimal classification of small and unbalanced datasets of spectrograms of glitches curated by *Gravity Spy*. This approach provided state-of-the-art classification accuracy, reduced the length of the training stage by several orders of magnitude, and eliminated the need for hyperparameter optimization. More importantly, both ResNet-50 and Inceptionv3 achieved a classification accuracy of 98.84% on the test set despite being trained independently via different methods on different splits of the data, and obtained 100.00% accuracy when considering the top five predictions. This means that for any given input, the true class can be narrowed down to within five classes with 100.00% confidence. This is particularly useful, since the true class of a glitch is often ambiguous, even to human experts. Finally, this study [99] also showed that neural networks may be truncated and used as feature extractors for unsupervised clustering to automatically group together new classes of glitches and noise anomalies.

Other techniques, such as multi-view convolutional neural networks [100] and similarity learning [101], have also been explored to automate glitch classification [100]. Discriminative embedding functions have also been explored to cluster glitches according to their morphology [102]. The use of machine learning to identify glitches by gathering information from environmental and detector data channels has also been reported in [103].

The development of a framework to enable online identification of simulated glitches was introduced in [104]. The wealth of curated data from *Gravity Spy* may soon enable online data quality studies, providing timely and critical input for low-latency gravitational wave detection and parameter estimation analyses.



### ***Deep Learning for the construction of Galaxy Catalogs in Large Scale Astronomy Surveys to enable gravitational wave standard-siren measurements of the Hubble constant***

The previous sections have summarized the state-of-the-art in deep learning applications for gravitational wave astrophysics. Deep learning is also being investigated in earnest to address computational grand challenges for large-scale electromagnetic and neutrino surveys [105].

This section showcases how to combine deep learning, distributed training and scientific visualization to automate the classification of galaxy images collected by different surveys. This work is timely and relevant in preparation for the next generation of electromagnetic surveys, which will significantly increase survey area, field of view, and alert production, leading to unprecedented volumes of image data and catalog sizes. Furthermore, since gravitational wave observations enable a direct measurement of the luminosity distance to their source [106], they may be used in conjunction with a catalog of potential host galaxies to establish a redshift-distance relationship and measure the Hubble constant. This has already been demonstrated in practice with the neutron star merger GW170817, whose electromagnetic counterpart allowed an unambiguous identification of its host galaxy [107]. Compact binary mergers without electromagnetic counterparts, such as the black hole merger GW170814, have been combined with galaxy catalogs provided by the Dark Energy Survey Year 3 [108] to estimate the Hubble constant. Therefore, to enable these type of statistical analysis it is necessary to automate the construction of complete galaxy catalogs [109].

A method to automate galaxy classification was introduced in [109]. The basic idea consists of leveraging the human-labelled galaxy images from the Galaxy Zoo project to fine-tune a neural network model that was originally pre-trained for real-object recognition using ImageNet. As described in [109], this approach not only enabled state-of-the-art classification for galaxies observed by the Sloan Digital Sky Survey (SDSS), but also for Dark Energy Survey (DES) galaxies. A fully trained model can classify about 10,000 test images within 10 minutes using a single Tesla P100 GPU.

**Interpretability** While the complexity of deep learning models is a major asset in processing large datasets and enabling data-driven discovery, it also poses major challenges to interpreting how these models acquire knowledge and use said knowledge to make predictions. This challenge has been widely recognized, and novel exploration techniques as well as visualization approaches are required to aid in deep learning model interpretability. Figure 10 present the activation maps of the second-to-last layer of the model described above for automated galaxy classification using t-SNE [110]. t-SNE is a nonlinear dimensionality reduction technique that is particularly apt for visualizing high-dimensional datasets by finding a faithful representation in a low-dimensional embedding, typically 2-D or 3-D. These 3-D projections are then visualized at different training iterations, and at the end of the training they neatly cluster into two groups, corresponding to spirals and elliptical.

A scientific visualization of this clustering algorithm for the entire Dark Energy Survey test set is presented at [111].

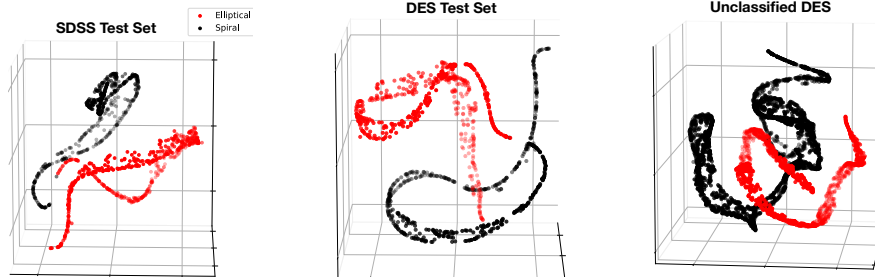

**Fig. 10** t-SNE visualization of the clustering of SDSS and DES test sets, and unlabelled DES test. This Figure was produced by the authors of this chapter in the published article [109].

In summary, methods that have been explored elsewhere for automated image classification, as in the case of glitch classification [99], may be seamlessly applied to galaxy classification [109]. This is an active area in deep learning research, i.e., the development of commodity tools that may be used across disciplines.

### *Challenges and Open Problems*

We have seen quite a few successful examples on how AI is able to improve the detection, parameter estimation, waveform production, and denoising of gravitational waves in the context of real advanced LIGO data. However, there are still important challenges to be addressed to turn AI into the preferred signal-processing tool for discovery at scale.

One major challenge is the huge computational cost for constructing and updating AI models, including exploration of the model architectures, hyper-parameter tuning, and training of AI models with streaming simulation/experimental data. To improve the convergence of training, we need to develop new initialization and optimization techniques for the network weights. Distributed training is also crucial for processing large simulation and observational data. In the section below, we detail our vision for combining AI and high performance computing for Multi-Messenger Astrophysics. We anticipate that in the future, we will have pre-trained AI models available in large-scale scientific, e.g., LIGO, LSTT, SKA, etc., for production scale classification and inference. It is important to incorporate computing at different levels, e.g., edge computing for real-time on-site prediction and cloud computing for updating the models with new training data to adapt to the changes in the sensitivity of detectors, and physical parameter space.

The AI models discussed in this chapter are trained with particular noise statistics. Previous works [71, 81, 84] have shown that the trained models are robust to small changes in noise statistics. As LIGO and other astronomical observatories continue to enhance their detection capabilities, researchers will uncover new types of noise anomalies that may contaminate or mimic transient astrophysical events. It is then important to develop new unsupervised and semi-supervised learning techniques to tell apart unexpected noise anomalies from real events. Since the noise statistics of observatories vary with time, it will be necessary to retrain the network models every few hours, a light-weight computational task that may readily be completed within a few minutes with cloud computing resources. This approach may also be useful to drive the convergence of centralized HPC platforms that are essential to accelerate the training of AI models from the ground up. Once fully trained, these AI models may be deployed at the edge to enable real-time inference of massive, multi-modal and complex datasets generated by scientific facilities. Thereafter, these models may be fine-tuned with light-weight, burst-like re-training sessions with cloud computing.

### ***Convergence of Deep Learning with High Performance Computing: An emergent framework for real-time Multi-Messenger Astrophysics discovery at scale***

This section provides a vision for the future of deep learning in Multi-Messenger Astrophysics. First, deep learning has rapidly evolved from a series of disparate efforts into a worldwide endeavor [105]. As described in the previous sections, there has been impressive progress across all fronts in gravitational wave astrophysics including detection, parameter estimation, data cleaning and denoising, and glitch classification. While the vast majority of these approaches have used vanilla neural network models, there is an emergent trend in which deep learning is combined with domain expertise to create physics-inspired architectures and optimization schemes to further improve neural network predictions [95].

Another interesting trend in recent studies is the use of high-dimensional signal manifolds—one of the key considerations that led to the exploration of deep learning. Applying deep learning to produce production-scale data analysis algorithms involves the combination of large datasets and distributed training on high performance computing platforms to reduce time-to-insight. This approach is in earnest development across disciplines, from plasma physics to genomics [112–115].

Figure 11 shows recent progress using the Summit supercomputer to accelerate by 600-fold the training of physics-inspired deep learning models for gravitational wave astrophysics [95]. Mirroring the successful approach of corporations that lead innovation in artificial intelligence research, projects such as the Data and Learning Hub for Science [116, 117] have provided an open source platform to share artificial intelligence models and data with the broader community. This approach will accel-

erate the development of novel artificial intelligence tools to enable breakthroughs in science and technology in the big data era.

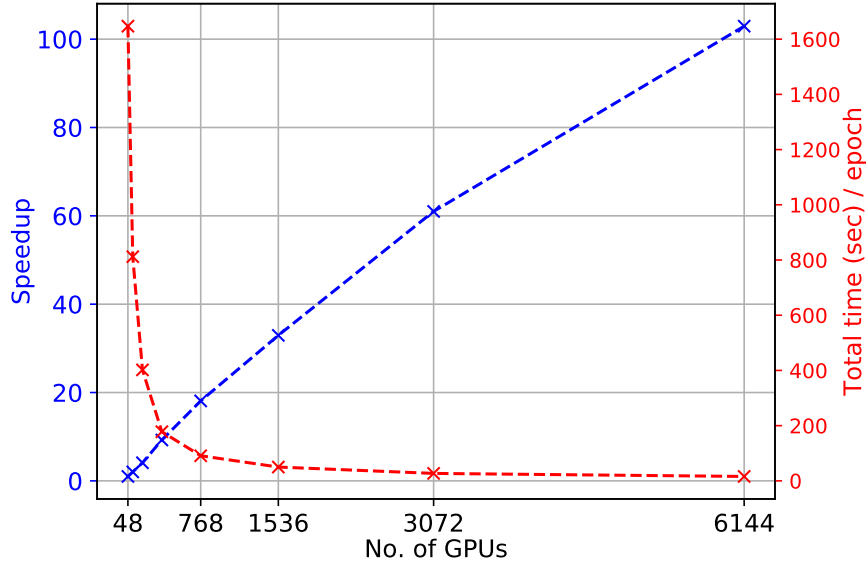

**Fig. 11** 600-fold speedup in training for a physics-inspired model to characterize the signal manifold of spinning binary black hole mergers. This acceleration is produced by deploying and tuning distributed training schemes on the Summit supercomputer at Oak Ridge National Laboratory. This Figure was produced by the authors of this chapter in the published article [95].

In addition to combining artificial intelligence and extreme-scale computing to reduce time-to-insight, there is an ongoing effort to incorporate artificial intelligence into the software stacks used to numerically simulate multi-scale and multi-physics processes, such as neutron star mergers [30]. Through these approaches, it may be feasible to accurately capture the physics of sub-scale processes such as turbulence at a fraction of the time and computational resources currently needed for high-quality simulations. In essence, this is promoting artificial intelligence as a guiding tool to maximize the use and reach of advanced cyberinfrastructure facilities.

Finally, as artificial intelligence and innovative computing become widely adopted as the go-to signal processing and computing paradigms, it is essential to not become complacent in the quest for better signal processing tools. Since the development of artificial intelligence goes well beyond academic pursuits, it will be important to keep transferring and cross-pollinating innovation between academia, industry and technology. At the same time, it is essential to keep pursuing translational research, e.g., how to reuse algorithms for real-object recognition in the context of glitch classification [99] and galaxy classification [109], or how to adapt and combine al-

gorithms for gravitational wave denoising [81] and earthquake detection [118] to other tasks, like the identification of heart conditions [119].

The future of artificial intelligence and innovative computing for Multi-Messenger Astrophysics is in the hands of bold innovators that will continue to expand the frontiers of discovery.

### ***Acknowledgements***

EAH and ZZ gratefully acknowledge National Science Foundation awards OAC-1931561 and OAC-1934757, Department of Energy award DE-SC0021258. EAH also acknowledges the Innovative and Novel Computational Impact on Theory and Experiment (INCITE) award “Multi-Messenger Astrophysics at Extreme Scale in Summit”. This research used resources of the Oak Ridge Leadership Computing Facility, which is a DOE Office of Science User Facility supported under Contract DE-AC05-00OR22725. We thank Roland Haas, Sarah Habib, Maeve Heflin, Xiaobo Huang, Asad Khan, Shawn Rosofsky, Hongyu Shen, Minyang Tian and William Wei for their contributions writing and editing this chapter.

## References

- [1] I. Goodfellow, Y. Bengio, and A. Courville, *Deep Learning*. MIT Press, 2016.
- [2] A. Einstein, “Die Feldgleichungen der Gravitation,” *Königlich Preussische Akademie der Wissenschaften Zu Berlin, Sitzungsberichte*, vol. 1915, pp. 844–847, 1915.
- [3] D. Kennefick, *Traveling at the Speed of Thought: Einstein and the Quest for Gravitational Waves*. Princeton University Press, 2007.
- [4] K. Schwarzschild, “On the gravitational field of a mass point according to Einstein’s theory,” *Sitzungsber. Preuss. Akad. Wiss. Berlin (Math. Phys. )*, vol. 1916, pp. 189–196, 1916.
- [5] H. Reissner, “Über die Eigengravitation des elektrischen Feldes nach der Einsteinschen Theorie,” *Annalen der Physik*, vol. 355, pp. 106–120, Jan. 1916.
- [6] R. P. Kerr, “Gravitational Field of a Spinning Mass as an Example of Algebraically Special Metrics,” *Physical Review Letters*, vol. 11, pp. 237–238, Sept. 1963.
- [7] E. T. Newman, E. Couch, K. Chinnapared, A. Exton, A. Prakash, and R. Torrence, “Metric of a Rotating, Charged Mass,” *Journal of Mathematical Physics*, vol. 6, pp. 918–919, June 1965.
- [8] L. Blanchet, “Gravitational Radiation from Post-Newtonian Sources and Inspiral Compact Binaries,” *Living Rev. Rel.*, vol. 17, p. 2, 2014.
- [9] L. Blanchet and T. Damour, “The post-Minkowskian iteration method and the structure of radiative gravitational fields,” *Academie des Science Paris Comptes Rendus Serie B Sciences Physiques*, vol. 298, pp. 431–434, Mar. 1984.
- [10] R. A. Matzner, H. E. Seidel, S. L. Shapiro, L. Smarr, W. M. Suen, S. A. Teukolsky, and J. Winicour, “Geometry of a Black Hole Collision,” *Science*, vol. 270, pp. 941–947, Nov. 1995.
- [11] F. Pretorius, “Evolution of Binary Black-Hole Spacetimes,” *Physical Review Letters*, vol. 95, pp. 121101–+, Sept. 2005.
- [12] M. Campanelli, C. O. Lousto, P. Marronetti, and Y. Zlochower, “Accurate Evolutions of Orbiting Black-Hole Binaries without Excision,” *Physical Review Letters*, vol. 96, p. 111101, Mar. 2006.
- [13] J. G. Baker, J. Centrella, D.-I. Choi, M. Koppitz, and J. van Meter, “Gravitational-Wave Extraction from an Inspiral Configuration of Merging Black Holes,” *Physical Review Letters*, vol. 96, p. 111102, Mar. 2006.
- [14] A. H. Mroue, M. A. Scheel, B. Szilagyi, H. P. Pfeiffer, M. Boyle, *et al.*, “A catalog of 174 binary black-hole simulations for gravitational-wave astronomy,” *Phys. Rev. Lett.*, vol. 111, p. 241104, 2013.
- [15] K. Jani, J. Healy, J. A. Clark, L. London, P. Laguna, and D. Shoemaker, “Georgia Tech Catalog of Gravitational Waveforms,” *Class. Quant. Grav.*, vol. 33, no. 20, p. 204001, 2016.
- [16] J. Healy and C. O. Lousto, “Third rit binary black hole simulations catalog,” *Phys. Rev. D*, vol. 102, p. 104018, Nov 2020.

- [17] E. A. Huerta, R. Haas, S. Habib, A. Gupta, A. Rebei, V. Chavva, D. Johnson, S. Rosofsky, E. Wessel, B. Agarwal, D. Luo, and W. Ren, “Physics of eccentric binary black hole mergers: A numerical relativity perspective,” *Phys. Rev. D*, vol. 100, p. 064003, Sept. 2019.
- [18] M. Hannam, P. Schmidt, A. Bohé, L. Haegel, S. Husa, F. Ohme, G. Pratten, and M. Pürrer, “Simple model of complete precessing black-hole-binary gravitational waveforms,” *Physical Review Letters*, vol. 113, no. 15, p. 151101, 2014.
- [19] A. Bohé *et al.*, “Improved effective-one-body model of spinning, nonprecessing binary black holes for the era of gravitational-wave astrophysics with advanced detectors,” *Phys. Rev.*, vol. D95, no. 4, p. 044028, 2017.
- [20] S. Khan, S. Husa, M. Hannam, F. Ohme, M. Pürrer, X. Jiménez Forteza, and A. Bohé, “Frequency-domain gravitational waves from nonprecessing black-hole binaries. II. A phenomenological model for the advanced detector era,” *Phys. Rev.*, vol. D93, no. 4, p. 044007, 2016.
- [21] B. Aylott *et al.*, “Testing gravitational-wave searches with numerical relativity waveforms: Results from the first Numerical INjection Analysis (NINJA) project,” *Class. Quant. Grav.*, vol. 26, p. 165008, 2009.
- [22] E. A. Huerta, C. J. Moore, P. Kumar, D. George, A. J. K. Chua, R. Haas, E. Wessel, D. Johnson, D. Glennon, A. Rebei, A. M. Holgado, J. R. Gair, and H. P. Pfeiffer, “Eccentric, nonspinning, inspiral, Gaussian-process merger approximant for the detection and characterization of eccentric binary black hole mergers,” *Phys. Rev. D*, vol. 97, p. 024031, Jan. 2018.
- [23] J. Blackman, S. E. Field, M. A. Scheel, C. R. Galley, D. A. Hemberger, P. Schmidt, and R. Smith, “A surrogate model of gravitational waveforms from numerical relativity simulations of precessing binary black hole mergers,” *Phys. Rev. D*, vol. 95, p. 104023, May 2017.
- [24] N. E. Rifat, S. E. Field, G. Khanna, and V. Varma, “Surrogate model for gravitational wave signals from comparable and large-mass-ratio black hole binaries,” *Phys. Rev. D*, vol. 101, no. 8, p. 081502, 2020.
- [25] B. D. Lackey, M. Pürrer, A. Taracchini, and S. Marsat, “Surrogate model for an aligned-spin effective one body waveform model of binary neutron star inspirals using Gaussian process regression,” *Phys. Rev. D*, vol. 100, no. 2, p. 024002, 2019.
- [26] V. Varma, S. E. Field, M. A. Scheel, J. Blackman, L. E. Kidder, and H. P. Pfeiffer, “Surrogate model of hybridized numerical relativity binary black hole waveforms,” *Phys. Rev. D*, vol. 99, no. 6, p. 064045, 2019.
- [27] D. Williams, I. S. Heng, J. Gair, J. A. Clark, and B. Khamesra, “Precessing numerical relativity waveform surrogate model for binary black holes: A gaussian process regression approach,” *Phys. Rev. D*, vol. 101, p. 063011, Mar 2020.
- [28] J. Blackman, S. E. Field, M. A. Scheel, C. R. Galley, C. D. Ott, M. Boyle, L. E. Kidder, H. P. Pfeiffer, and B. Szilágyi, “Numerical relativity waveform surrogate model for generically precessing binary black hole mergers,” *Phys. Rev. D*, vol. 96, p. 024058, July 2017.

- [29] F. Foucart *et al.*, “Gravitational waveforms from spectral Einstein code simulations: Neutron star-neutron star and low-mass black hole-neutron star binaries,” *Phys. Rev. D*, vol. 99, no. 4, p. 044008, 2019.
- [30] S. G. Rosofsky and E. A. Huerta, “Artificial neural network subgrid models of 2D compressible magnetohydrodynamic turbulence,” *Phys. Rev. D*, vol. 101, p. 084024, Apr. 2020.
- [31] J. Veitch, V. Raymond, B. Farr, W. Farr, P. Graff, S. Vitale, B. Aylott, K. Blackburn, N. Christensen, M. Coughlin, W. Del Pozzo, F. Feroz, J. Gair, C.-J. Haster, V. Kalogera, T. Littenberg, I. Mandel, R. O’Shaughnessy, M. Pitkin, C. Rodriguez, C. Röver, T. Sidery, R. Smith, M. Van Der Sluys, A. Vecchio, W. Vousden, and L. Wade, “Parameter estimation for compact binaries with ground-based gravitational-wave observations using the LAL-Inference software library,” *Phys. Rev. D*, vol. 91, p. 042003, Feb. 2015.
- [32] C. Biwer, C. D. Capano, S. De, M. Cabero, D. A. Brown, A. H. Nitz, and V. Raymond, “PyCBC Inference: A Python-based parameter estimation toolkit for compact binary coalescence signals,” *Publ. Astron. Soc. Pac.*, vol. 131, no. 996, p. 024503, 2019.
- [33] J. Skilling, “Nested sampling for general bayesian computation,” *Bayesian analysis*, vol. 1, no. 4, pp. 833–859, 2006.
- [34] C. Andrieu, N. De Freitas, A. Doucet, and M. Jordan, “An introduction to mcmc for machine learning,” *Machine Learning*, vol. 50, pp. 5–43, Jan. 2003.
- [35] J. Lange, R. O’Shaughnessy, and M. Rizzo, “Rapid and accurate parameter inference for coalescing, precessing compact binaries,” *arXiv preprint arXiv:1805.10457*, 2018.
- [36] F. Feroz, J. R. Gair, M. P. Hobson, and E. K. Porter, “Use of the MultiNest algorithm for gravitational wave data analysis,” *Class. Quant. Grav.*, vol. 26, p. 215003, 2009.
- [37] P. Graff, F. Feroz, M. P. Hobson, and A. Lasenby, “BAMBI: blind accelerated multimodal Bayesian inference,” *MNRAS*, vol. 421, pp. 169–180, Mar. 2012.
- [38] D. Chatterjee, S. Ghosh, P. R. Brady, S. J. Kapadia, A. L. Miller, S. Nissanke, and F. Pannarale, “A Machine Learning Based Source Property Inference for Compact Binary Mergers,” *Astrophys. J.*, vol. 896, no. 1, p. 54, 2020.
- [39] I. Mandel, W. M. Farr, A. Colonna, S. Stevenson, P. Tiño, and J. Veitch, “Model-independent inference on compact-binary observations,” *Mon. Not. Roy. Astron. Soc.*, vol. 465, no. 3, pp. 3254–3260, 2017.
- [40] J. Powell, S. Stevenson, I. Mandel, and P. Tino, “Unmodelled Clustering Methods for Gravitational Wave Populations of Compact Binary Mergers,” *Mon. Not. Roy. Astron. Soc.*, vol. 488, no. 3, pp. 3810–3817, 2019.
- [41] Jingdong Chen, J. Benesty, Yiteng Huang, and S. Doclo, “New insights into the noise reduction wiener filter,” *IEEE Transactions on Audio, Speech, and Language Processing*, vol. 14, no. 4, pp. 1218–1234, 2006.
- [42] G. Vajente, Y. Huang, M. Isi, J. C. Driggers, J. S. Kissel, M. J. Szczepańczyk, and S. Vitale, “Machine-learning nonstationary noise out of gravitational-wave detectors,” *Phys. Rev. D*, vol. 101, p. 042003, Feb 2020.



- [43] M. Cavaglia, K. Staats, and T. Gill, “Finding the origin of noise transients in ligo data with machine learning,” *Communications in Computational Physics*, vol. 25, no. 4, 2019.
- [44] N. J. Cornish and T. B. Littenberg, “BayesWave: Bayesian Inference for Gravitational Wave Bursts and Instrument Glitches,” *Class. Quant. Grav.*, vol. 32, no. 13, p. 135012, 2015.
- [45] A. Torres-Forné, A. Marquina, J. A. Font, and J. M. Ibáñez, “Denoising of gravitational wave signals via dictionary learning algorithms,” *Phys. Rev. D*, vol. 94, no. 12, p. 124040, 2016.
- [46] A. Torres-Forné, E. Cuoco, J. A. Font, and A. Marquina, “Application of dictionary learning to denoise ligo’s blip noise transients,” *Phys. Rev. D*, vol. 102, p. 023011, Jul 2020.
- [47] I. S. Heng, “Rotating stellar core-collapse waveform decomposition: a principal component analysis approach,” *Classical and Quantum Gravity*, vol. 26, p. 105005, apr 2009.
- [48] A. Torres, A. Marquina, J. A. Font, and J. M. Ibáñez, “Total-variation-based methods for gravitational wave denoising,” *Phys. Rev. D*, vol. 90, p. 084029, Oct 2014.
- [49] S. A. Usman *et al.*, “The PyCBC search for gravitational waves from compact binary coalescence,” *Classical and Quantum Gravity*, vol. 33, p. 215004, Nov. 2016.
- [50] S. Sachdev *et al.*, “The GstLAL Search Analysis Methods for Compact Binary Mergers in Advanced LIGO’s Second and Advanced Virgo’s First Observing Runs,” *arXiv preprint arXiv:1901.08580*, 2019.
- [51] S. Klimenko, G. Vedovato, M. Drago, F. Salemi, V. Tiwari, G. A. Prodi, C. Lazzaro, K. Ackley, S. Tiwari, C. F. Da Silva, and G. Mitselmakher, “Method for detection and reconstruction of gravitational wave transients with networks of advanced detectors,” *Phys. Rev. D*, vol. 93, p. 042004, Feb 2016.
- [52] K. Riles, “Recent searches for continuous gravitational waves,” *Mod. Phys. Lett. A*, vol. 32, no. 39, p. 1730035, 2017.
- [53] S. J. Tingay, “An overview of the SKA project: Why take on this signal processing challenge?,” in *2015 IEEE International Conference on Acoustics, Speech and Signal Processing (ICASSP)*, pp. 5640–5644, 2015.
- [54] G. Apollinari, I. Béjar Alonso, O. Brüning, P. Fessia, M. Lamont, L. Rossi, and L. Taviani, “High-Luminosity Large Hadron Collider (HL-LHC): Technical Design Report V. 0.1,” tech. rep., CYRM-2017-004, 11 2017.
- [55] “Large synoptic survey telescope. system and survey key numbers.” <https://www.lsst.org/scientists/keynumbers>.
- [56] D. George and E. A. Huerta, “Deep neural networks to enable real-time multimessenger astrophysics,” *Phys. Rev. D*, vol. 97, p. 044039, Feb 2018.
- [57] Y. LeCun, Y. Bengio, and G. Hinton, “Deep learning,” *Nature*, vol. 521, no. 7553, pp. 436–444, 2015.

- [58] D. George and E. Huerta, “Deep learning for real-time gravitational wave detection and parameter estimation: Results with advanced ligo data,” *Physics Letters B*, vol. 778, pp. 64 – 70, 2018.
- [59] Y. Bengio, J. Louradour, R. Collobert, and J. Weston, “Curriculum learning,” in *Proceedings of the 26th Annual International Conference on Machine Learning*, vol. 60, p. 6, 01 2009.
- [60] H. Gabbard, M. Williams, F. Hayes, and C. Messenger, “Matching Matched Filtering with Deep Networks for Gravitational-Wave Astronomy,” *Physical Review Letters*, vol. 120, p. 141103, Apr. 2018.
- [61] V. Skliris, M. R. K. Norman, and P. J. Sutton, “Real-Time Detection of Unmodeled Gravitational-Wave Transients Using Convolutional Neural Networks,” *arXiv e-prints*, p. arXiv:2009.14611, Sept. 2020.
- [62] Y.-C. Lin and J.-H. P. Wu, “Detection of gravitational waves using bayesian neural networks,” *Phys. Rev. D*, vol. 103, p. 063034, Mar 2021.
- [63] H. Wang, S. Wu, Z. Cao, X. Liu, and J.-Y. Zhu, “Gravitational-wave signal recognition of LIGO data by deep learning,” *Phys. Rev. D*, vol. 101, no. 10, p. 104003, 2020.
- [64] H. Nakano, T. Narikawa, K.-i. Oohara, K. Sakai, H.-a. Shinkai, H. Takahashi, T. Tanaka, N. Uchikata, S. Yamamoto, and T. S. Yamamoto, “Comparison of various methods to extract ringdown frequency from gravitational wave data,” *Phys. Rev. D*, vol. 99, no. 12, p. 124032, 2019.
- [65] X. Fan, J. Li, X. Li, Y. Zhong, and J. Cao, “Applying deep neural networks to the detection and space parameter estimation of compact binary coalescence with a network of gravitational wave detectors,” *Sci. China Phys. Mech. Astron.*, vol. 62, no. 6, p. 969512, 2019.
- [66] X.-R. Li, G. Babu, W.-L. Yu, and X.-L. Fan, “Some optimizations on detecting gravitational wave using convolutional neural network,” *Front. Phys. (Beijing)*, vol. 15, no. 5, p. 54501, 2020.
- [67] D. S. Deighan, S. E. Field, C. D. Capano, and G. Khanna, “Genetic-algorithm-optimized neural networks for gravitational wave classification,” *arXiv e-prints*, p. arXiv:2010.04340, Oct. 2020.
- [68] A. L. Miller *et al.*, “How effective is machine learning to detect long transient gravitational waves from neutron stars in a real search?,” *Phys. Rev. D*, vol. 100, no. 6, p. 062005, 2019.
- [69] P. G. Krastev, “Real-Time Detection of Gravitational Waves from Binary Neutron Stars using Artificial Neural Networks,” *Phys. Lett. B*, vol. 803, p. 135330, 2020.
- [70] M. B. Schäfer, F. Ohme, and A. H. Nitz, “Detection of gravitational-wave signals from binary neutron star mergers using machine learning,” *Phys. Rev. D*, vol. 102, p. 063015, Sept. 2020.
- [71] W. Wei and E. A. Huerta, “Deep learning for gravitational wave forecasting of neutron star mergers,” *Phys. Lett. B*, vol. 816, p. 136185, 2021.
- [72] W. Wei, E. A. Huerta, M. Yun, N. Loutrel, R. Haas, and V. Kindratenko, “Deep Learning with Quantized Neural Networks for Gravitational Wave

- Forecasting of Eccentric Compact Binary Coalescence,” *arXiv e-prints*, p. arXiv:2012.03963, Dec. 2020.
- [73] C. Dreissigacker and R. Prix, “Deep-Learning Continuous Gravitational Waves: Multiple detectors and realistic noise,” *Phys. Rev. D*, vol. 102, no. 2, p. 022005, 2020.
- [74] C. Dreissigacker, R. Sharma, C. Messenger, R. Zhao, and R. Prix, “Deep-Learning Continuous Gravitational Waves,” *Phys. Rev. D*, vol. 100, no. 4, p. 044009, 2019.
- [75] B. Beheshtipour and M. A. Papa, “Deep learning for clustering of continuous gravitational wave candidates,” *Phys. Rev. D*, vol. 101, p. 064009, Mar. 2020.
- [76] S. Khan and R. Green, “Gravitational-wave surrogate models powered by artificial neural networks: The ANN-Sur for waveform generation,” *arXiv preprint arXiv:2008.12932*, 2020.
- [77] A. J. K. Chua, C. R. Galley, and M. Vallisneri, “Reduced-order modeling with artificial neurons for gravitational-wave inference,” *Phys. Rev. Lett.*, vol. 122, p. 211101, May 2019.
- [78] W. Wei, A. Khan, E. A. Huerta, X. Huang, and M. Tian, “Deep learning ensemble for real-time gravitational wave detection of spinning binary black hole mergers,” *Physics Letters B*, vol. 812, p. 136029, Jan. 2021.
- [79] E. A. Huerta, A. Khan, X. Huang, M. Tian, M. Levental, R. Chard, W. Wei, M. Heflin, D. S. Katz, V. Kindratenko, D. Mu, B. Blaiszik, and I. Foster, “Confluence of Artificial Intelligence and High Performance Computing for Accelerated, Scalable and Reproducible Gravitational Wave Detection,” *arXiv e-prints*, p. arXiv:2012.08545, Dec. 2020.
- [80] H. Shen, D. George, E. A. Huerta, and Z. Zhao, “Denoising gravitational waves with enhanced deep recurrent denoising auto-encoders,” in *ICASSP 2019-2019 IEEE International Conference on Acoustics, Speech and Signal Processing (ICASSP)*, pp. 3237–3241, IEEE, 2019.
- [81] W. Wei and E. A. Huerta, “Gravitational Wave Denoising of Binary Black Hole Mergers with Deep Learning,” *Phys. Lett.*, vol. B800, p. 135081, 2020.
- [82] A. van den Oord, S. Dieleman, H. Zen, K. Simonyan, O. Vinyals, A. Graves, N. Kalchbrenner, A. Senior, and K. Kavukcuoglu, “WaveNet: A Generative Model for Raw Audio,” in *9th ISCA Speech Synthesis Workshop*, pp. 125–125, 2016.
- [83] R. Ormiston, T. Nguyen, M. Coughlin, R. X. Adhikari, and E. Katsavounidis, “Noise reduction in gravitational-wave data via deep learning,” *Phys. Rev. Research*, vol. 2, p. 033066, Jul 2020.
- [84] H. Shen, E. A. Huerta, E. O’Shea, P. Kumar, and Z. Zhao, “Statistically-informed deep learning for gravitational wave parameter estimation,” *arXiv e-prints*, p. arXiv:1903.01998, Mar. 2019.
- [85] H. Gabbard, C. Messenger, I. S. Heng, F. Tonolini, and R. Murray-Smith, “Bayesian parameter estimation using conditional variational autoencoders for gravitational-wave astronomy,” *arXiv preprint arXiv:1909.06296*, 2019.

- [86] A. J. Chua and M. Vallisneri, “Learning Bayesian posteriors with neural networks for gravitational-wave inference,” *Phys. Rev. Lett.*, vol. 124, no. 4, p. 041102, 2020.
- [87] S. R. Green, C. Simpson, and J. Gair, “Gravitational-wave parameter estimation with autoregressive neural network flows,” *Phys. Rev. D*, vol. 102, p. 104057, Nov 2020.
- [88] S. R. Green and J. Gair, “Complete parameter inference for GW150914 using deep learning,” *arXiv preprint arXiv:2008.03312*, 2020.
- [89] K. W. Wong, K. K. Ng, and E. Berti, “Gravitational-wave signal-to-noise interpolation via neural networks,” *arXiv preprint arXiv:2007.10350*, 2020.
- [90] J. Samsing, “Eccentric black hole mergers forming in globular clusters,” *Phys. Rev. D*, vol. 97, p. 103014, May 2018.
- [91] A. Rebei, E. A. Huerta, S. Wang, S. Habib, R. Haas, D. Johnson, and D. George, “Fusing numerical relativity and deep learning to detect higher-order multipole waveforms from eccentric binary black hole mergers,” *Phys. Rev. D*, vol. 100, p. 044025, Aug 2019.
- [92] D. A. Brown, P. Kumar, and A. H. Nitz, “Template banks to search for low-mass binary black holes in advanced gravitational-wave detectors,” *Phys. Rev. D*, vol. 87, p. 082004, Apr. 2013.
- [93] E. Berti, A. Sesana, E. Barausse, V. Cardoso, and K. Belczynski, “Spectroscopy of Kerr Black Holes with Earth- and Space-Based Interferometers,” *Physical Review Letters*, vol. 117, p. 101102, Sept. 2016.
- [94] K. Yagi and L. C. Stein, “Black hole based tests of general relativity,” *Classical and Quantum Gravity*, vol. 33, p. 054001, Mar. 2016.
- [95] A. Khan, E. Huerta, and A. Das, “Physics-inspired deep learning to characterize the signal manifold of quasi-circular, spinning, non-precessing binary black hole mergers,” *Physics Letters B*, vol. 808, p. 135628, 2020.
- [96] V. Varma, S. E. Field, M. A. Scheel, J. Blackman, L. E. Kidder, and H. P. Pfeiffer, “Surrogate model of hybridized numerical relativity binary black hole waveforms,” *Phys. Rev. D*, vol. 99, p. 064045, Mar 2019.
- [97] B. P. Abbott, R. Abbott, T. D. Abbott, M. R. Abernathy, F. Acernese, K. Ackley, C. Adams, T. Adams, P. Addesso, R. X. Adhikari, and et al., “Prospects for Observing and Localizing Gravitational-Wave Transients with Advanced LIGO and Advanced Virgo,” *Living Reviews in Relativity*, vol. 19, Feb. 2016.
- [98] M. Zevin, S. Coughlin, S. Bahaadini, E. Besler, N. Rohani, S. Allen, M. Cabero, K. Crowston, A. K. Katsaggelos, S. L. Larson, T. K. Lee, C. Lintott, T. B. Littenberg, A. Lundgren, C. Østerlund, J. R. Smith, L. Trouille, and V. Kalogera, “Gravity Spy: integrating advanced LIGO detector characterization, machine learning, and citizen science,” *Classical and Quantum Gravity*, vol. 34, p. 064003, Mar. 2017.
- [99] D. George, H. Shen, and E. A. Huerta, “Classification and unsupervised clustering of LIGO data with Deep Transfer Learning,” *Phys. Rev. D*, vol. 97, p. 101501, May 2018.
- [100] S. Bahaadini, N. Rohani, S. Coughlin, M. Zevin, V. Kalogera, and A. K. Katsaggelos, “Deep multi-view models for glitch classification,” in *2017*

- IEEE International Conference on Acoustics, Speech and Signal Processing (ICASSP)*, pp. 2931–2935, IEEE, 2017.
- [101] S. Coughlin, S. Bahaadini, N. Rohani, M. Zevin, O. Patane, M. Harandi, C. Jackson, V. Noroozi, S. Allen, J. Areeda, M. Coughlin, P. Ruiz, C. P. L. Berry, K. Crowston, A. K. Katsaggelos, A. Lundgren, C. Østerlund, J. R. Smith, L. Trouille, and V. Kalogera, “Classifying the unknown: Discovering novel gravitational-wave detector glitches using similarity learning,” *Phys. Rev. D*, vol. 99, p. 082002, Apr. 2019.
- [102] S. Bahaadini, N. Rohani, A. K. Katsaggelos, V. Noroozi, S. Coughlin, and M. Zevin, “Direct: Deep discriminative embedding for clustering of LIGO data,” in *2018 25th IEEE International Conference on Image Processing (ICIP)*, pp. 748–752, IEEE, 2018.
- [103] R. E. Colgan, K. R. Corley, Y. Lau, I. Bartos, J. N. Wright, Z. Márka, and S. Márka, “Efficient gravitational-wave glitch identification from environmental data through machine learning,” *Phys. Rev. D*, vol. 101, p. 102003, May 2020.
- [104] M. Razzano and E. Cuoco, “Image-based deep learning for classification of noise transients in gravitational wave detectors,” *Classical and Quantum Gravity*, vol. 35, p. 095016, May 2018.
- [105] E. A. Huerta, G. Allen, I. Andreoni, J. M. Antelis, E. Bachelet, G. B. Berriman, F. B. Bianco, R. Biswas, M. Carrasco Kind, K. Chard, M. Cho, P. S. Cowperthwaite, Z. B. Etienne, M. Fishbach, F. Forster, D. George, T. Gibbs, M. Graham, W. Gropp, R. Gruendl, A. Gupta, R. Haas, S. Habib, E. Jennings, M. W. G. Johnson, E. Katsavounidis, D. S. Katz, A. Khan, V. Kindratenko, W. T. C. Kramer, X. Liu, A. Mahabal, Z. Marka, K. McHenry, J. M. Miller, C. Moreno, M. S. Neubauer, S. Oberlin, A. R. Olivás, D. Petravick, A. Rebei, S. Rosofsky, M. Ruiz, A. Saxton, B. F. Schutz, A. Schwing, E. Seidel, S. L. Shapiro, H. Shen, Y. Shen, L. P. Singer, B. M. Sipocz, L. Sun, J. Towns, A. Tsokaros, W. Wei, J. Wells, T. J. Williams, J. Xiong, and Z. Zhao, “Enabling real-time multi-messenger astrophysics discoveries with deep learning,” *Nature Reviews Physics*, vol. 1, pp. 600–608, Oct. 2019.
- [106] B. F. Schutz, “Determining the Hubble constant from gravitational wave observations,” *Nature*, vol. 323, p. 310, Sept. 1986.
- [107] B. P. Abbott *et al.*, “A gravitational-wave standard siren measurement of the Hubble constant,” *Nature*, vol. 551, pp. 85–88, Nov. 2017.
- [108] M. Soares-Santos *et al.*, “First Measurement of the Hubble Constant from a Dark Standard Siren using the Dark Energy Survey Galaxies and the LIGO/Virgo Binary–Black-hole Merger GW170814,” *Astrophys. J. Lett.*, vol. 876, no. 1, p. L7, 2019.
- [109] A. Khan, E. A. Huerta, S. Wang, R. Gruendl, E. Jennings, and H. Zheng, “Deep learning at scale for the construction of galaxy catalogs in the Dark Energy Survey,” *Physics Letters B*, vol. 795, pp. 248–258, Aug. 2019.
- [110] L. van der Maaten and G. Hinton, “Visualizing data using t-SNE,” *Journal of machine learning research*, vol. 9, no. Nov, pp. 2579–2605, 2008.

- [111] A. Khan, E. A. Huerta, S. Wang, R. Gruendl, E. Jennings, and H. Zheng, “Deep transfer learning at scale for cosmology,” 2018. <https://www.youtube.com/watch?v=1F3q7M8QjTQ>.
- [112] E. A. Huerta, A. Khan, E. Davis, C. Bushell, W. D. Gropp, D. S. Katz, V. Kindratenko, S. Koric, W. T. C. Kramer, B. McGinty, K. McHenry, and A. Saxton, “Convergence of Artificial Intelligence and High Performance Computing on NSF-supported Cyberinfrastructure,” *Journal of Big Data*, vol. 7, no. 1, p. 88, 2020.
- [113] D. Guest, K. Cranmer, and D. Whiteson, “Deep learning and its application to lhc physics,” *Annual Review of Nuclear and Particle Science*, vol. 68, no. 1, pp. 161–181, 2018.
- [114] L. Ward, B. Blaiszik, I. Foster, R. S. Assary, B. Narayanan, and L. Curtiss, “Machine learning prediction of accurate atomization energies of organic molecules from low-fidelity quantum chemical calculations,” *MRS Communications*, vol. 9, no. 3, pp. 891–899, 2019.
- [115] C. Blatti, A. Emad, M. J. Berry, L. Gatzke, M. Epstein, D. Lanier, P. Rizal, J. Ge, X. Liao, O. Sobh, M. Lambert, C. S. Post, J. Xiao, P. Groves, A. T. Epstein, X. Chen, S. Srinivasan, E. Lehnert, K. R. Kalari, L. Wang, R. M. Weinshilboum, J. S. Song, C. V. Jongeneel, J. Han, U. Ravaoli, N. Sobh, C. B. Bushell, and S. Sinha, “Knowledge-guided analysis of ‘omics’ data using the KnowEnG cloud platform,” *PLoS biology*, 2020.
- [116] R. Chard, Z. Li, K. Chard, L. Ward, Y. Babuji, A. Woodard, S. Tuecke, B. Blaiszik, M. J. Franklin, and I. Foster, “Dlhub: Model and data serving for science,” in *2019 IEEE International Parallel and Distributed Processing Symposium (IPDPS)*, pp. 283–292, 2019.
- [117] B. Blaiszik, L. Ward, M. Schwarting, J. Gaff, R. Chard, D. Pike, K. Chard, and I. Foster, “A data ecosystem to support machine learning in materials science,” *MRS Communications*, vol. 9, no. 4, pp. 1125–1133, 2019.
- [118] T. Perol, M. Gharbi, and M. Denolle, “Convolutional neural network for earthquake detection and location,” *Science Advances*, vol. 4, no. 2, 2018.
- [119] A. Gupta, E. Huerta, Z. Zhao, and I. Moussa, “Deep learning for cardiologist-level myocardial infarction detection in electrocardiograms,” in *8th European Medical and Biological Engineering Conference* (T. Jarm, A. Cvetkoska, S. Mahnič-Kalamiza, and D. Miklavcic, eds.), (Cham), pp. 341–355, Springer International Publishing, 2021.