

# An Evaluation of Cryptocurrency Payment Channel Networks and Their Privacy Implications

Enes Erdin\*, Suat Mercan<sup>†</sup>, and Kemal Akkaya<sup>†</sup>

\*Department of Computer Science, University of Central Arkansas, Conway, AR 72035, USA

Email: {eerdin}@uca.edu

<sup>†</sup>Dept. of Elec. and Comp. Engineering, Florida International University, Miami, FL 33174

Email: {smercan,kakkaya}@fiu.edu

**Abstract**—Cryptocurrencies redefined how money can be stored and transferred among users. However, independent of the amount being sent, public blockchain-based cryptocurrencies suffer from high transaction waiting times and fees. These drawbacks hinder the wide use of cryptocurrencies by masses. To address these challenges, payment channel network concept is touted as the most viable solution to be used for micro-payments. The idea is exchanging the ownership of money by keeping the state of the accounts locally. The users inform the blockchain rarely, which decreases the load on the blockchain. Specifically, payment channel networks can provide transaction approvals in seconds by charging a nominal fee proportional to the payment amount. Such attraction on payment channel networks inspired many recent studies which focus on how to design them and allocate channels such that the transactions will be secure and efficient. However, as payment channel networks are emerging and reaching large number of users, privacy issues are becoming more relevant that raise concerns about exposing not only individual habits but also businesses' revenues. In this paper, we first propose a categorization of the existing payment networks formed on top of blockchain-backed cryptocurrencies. After discussing several emerging attacks on user/business privacy in these payment channel networks, we qualitatively evaluate them based on a number of privacy metrics that relate to our case. Based on the discussions on the strengths and weaknesses of the approaches, we offer possible directions for research for the future of privacy based payment channel networks.

**Index Terms**—Blockchain, Bitcoin, Lightning Network, Routing Protocols, Payment Channel Network

## I. INTRODUCTION

There are many modern money exchange systems such as paper checks, credit/debit cards, automated clearing house (ACH) payments, bank transfers, or digital cash which are owned and regulated by financial institutions. Nevertheless, in the evolving world of trade, the movement of money is still going through changes. The last decade witnessed the introduction of *Bitcoin* [1], a new paradigm-shifting innovation where the users control their own money without needing a trusted third party. In this model, the users are governing the system by coming to a consensus for controlling the transfer and the ownership of the money. Following the success of Bitcoin, new cryptocurrencies that offer new capabilities were introduced based on the idea of consensus-based account management [2], [3].

In the following years, the initial success of cryptocurrencies was hindered due to practical issues related its daily use.

Basically, it was a very limited system in terms of scalability and its wide usage in simple daily transactions was quite impossible due to long waiting times, high disproportional transaction fees, and low throughput.

Among many solutions *payment channel* idea arose as a well-accepted one for solving mentioned problems. The idea is based on establishing off-chain links between parties so that many of the transactions would not be written to the blockchain each time. The payment channel idea later evolved towards the establishment of *payment channel networks* (PCN), where among many participants and channels the participants pay by using others as relays, essentially forming a connected network. This is in essence a *Layer-2* network application running on top of a cryptocurrency, which covers *Layer-1* services. A perfect example to PCNs is Lightning Network (LN) [4] which uses Bitcoin and reached to many users in a very short amount of time. Raiden [5], based on Ethereum, is another example for a successful PCN.

The emergence of PCNs led to several research challenges. In particular, security of the off-chain payments is very important as users can lose money or liability can be denied. In addition, efficiency of payment routing within the PCN with large number of users is tackled. Such efforts paved the way for introducing many new PCNs in addition to LN. These PCNs rely on various cryptocurrencies and carry several new features. As these newly proposed PCNs become more prominent there will be a heavy user and business involvement which will raise issues regarding their privacy just as the user privacy on Internet. The difference is that on many cases, Internet privacy could be regulated but this will not be the case for PCNs as their very idea is based on decentralization. For instance, a user will naturally want to stay anonymous to the rest of the network while a business would like to keep its revenue private against its competitors.

Therefore, in this paper, we investigate this very emerging issue and provide an analysis of current PCNs along with their privacy implications. We first categorize the PCNs in the light of common network architectures and blockchain types. We then define user and business privacy within the context of PCNs, and discuss possible attacks on the privacy of the participants. Specifically, we came up with novel privacy risks specific to PCNs. Utilizing these attack scenarios, we later survey and evaluate thoroughly the existing PCNs in terms

of their privacy capabilities based on certain metrics. This is a novel qualitative evaluation to be able to compare what each PCN is offering in terms of its privacy features. Finally, we offer potential future research issues that can be further investigated in the context of PCN privacy. Our work not only is the first to increase awareness regarding the privacy issues in the emerging realm of PCNs but also will help practitioners on selecting the best PCN for their needs.

The paper is organized as follows: Section II gives an introductory background. Next, Section III categorizes the PCNs in the light of common network architectures and blockchain types. In Section IV we define the user and business privacy, discuss possible attacks on the privacy of the participants in the PCNs, and present an evaluation of state-of-the-art solutions for what they offer in terms of privacy. Section V offers directions about the future research on privacy in PCNs and Section VI concludes the paper.

## II. BACKGROUND

### A. Blockchain

Blockchain is the underlying technology in cryptocurrency, that brings a new distributed database which is a public, transparent, persistent, and append-only ledger co-hosted by the participants. With various cryptographically verifiable methods, called *Proof-of-X* (PoX), each participant in the network holds the power of moderation of the blockchain [6]. As an example, Bitcoin and Ethereum, which jointly hold 75% of total market capitalization in the cryptocurrency world, utilize *proof-of-work* (PoW) mechanism where a participant has to find a “block-hash-value” smaller than a jointly agreed number. A block is an element with a limited size that stores the transaction information. Each block holds the hash of the preceding block which in the long run forms a chain of blocks, called, the blockchain. “Who-owns-what” information is embedded in the blockchain as transaction information. Therefore, the cohort of independent participants turns blockchain into a liberated data/asset management technology free of trusted third parties.

### B. Cryptocurrency

Although it finds many areas, the most commonly used application of blockchain technology is cryptocurrencies. A *cryptocurrency* is a cryptographically secure and verifiable currency that can be used to purchase goods and services. In this paper, we will use cryptocurrency and money interchangeably.

Blockchain technology undoubtedly changed the way data can be transferred, stored, and represented. Nonetheless, making a consensus on the final state of a distributed ledger has drawbacks. The first drawback is long transaction confirmation times. For example, in Bitcoin, a block is generated at about every 10 minutes. As a heuristic Bitcoin users wait 6 blocks for the finality of a transaction which yields almost 60 minutes. In Ethereum, time between blocks are shorter but users wait 30 consecutive blocks which yields 10-15 minutes of waiting time. Note that, as a block is limited in size, not only the throughput will be limited, but also the total waiting time

for the users will be longer during the congested times of the transfer requests. Nevertheless, if a user is in a hurry for approval of its transaction, it will need to pay larger fees to miners than what its competitors pay. This brings us the second drawback of using blockchain for cryptocurrency. The miner nodes, which generate and approve blocks, get fees from the users to include transactions in blocks. So when there is congestion, a payer either has to offer more fee or she/he has to wait more so that a miner picks her/his transaction request.

### C. Smart Contracts

The ability to employ smart contracts is another feature that makes blockchain an unorthodox asset management technology. Smart contracts are scripts or bytecodes, which define how transactions will take place based on the future events defined within the contract. Smart contracts can be utilized in conditional/unconditional peer-to-peer (P2P) transactions, voting, legal testament etc. As always, the duty of decision-making is on blockchain. Hence, the blockchain finalizes the transaction outputs when the smart contracts are utilized too.

## III. PCNs AND THEIR CATEGORIZATION

### A. Payment Channel Networks

Due to the scalability issues researchers have always been in the search of solutions to make the cryptocurrency scalable. Among many offered solutions, the *off-chain* payment channel idea has attracted the most interest. To establish such a channel, two parties agree on depositing some money in a multi-signature (2-of-2 multi-sig) wallet with the designated ownership of their share. The multi-sig wallet is created by a smart contract where both parties sign. The smart contract, mediated by the blockchain, includes the participants’ addresses, their share in the wallet, and information on how the contract will be honored. Approval of the opening transaction in the blockchain initiates the channel. The idea is simple; the payer side gives ownership of some of his/her money to the other side by locally updating the contract mutually. To close the channel the parties submit “closing transaction” to the blockchain for it to honor the final state of the channel. Thus, each side receives its own share from the multi-sig wallet.

Payment channels created among many parties make establishment of *multi-hop payments* from a source to a destination through intermediary nodes possible. As shown in Fig. 1, Alice-Charlie (A-C) and Charlie-Bob (C-B) have channels. Let, A-C and C-B are initialized when time is  $t$ . Although Alice does not have a direct channel to Bob, she can still pay Bob via Charlie. At time  $t+x_1$ , Alice initiates a transfer of 10 units to Bob. The money is destined to Bob over Charlie. When Charlie honors this transaction in the C-B channel by giving 10 units to Bob, Alice gives 10 units of her share to Charlie in A-C channel. When the transfers are over, A-C and C-B channels get updated. When time is  $t+x_2$ , Alice makes another transaction (20 units) to Bob and the shares in the channels get updated once again.

Multi-hop payment concept enables the establishment of a network of payment channels among users, which is referred

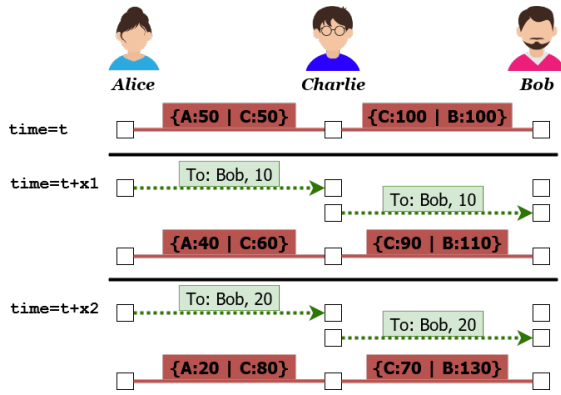

Fig. 1. A Simple Multi-hop Payment. Alice can initiate a transfer to Bob utilizing channels between Alice-Charlie and Charlie-Bob.

to as PCN as shown in Fig. 2. Current PCNs vary in terms of what topologies they depend on and which layer-1 blockchain technology they utilize. We discuss this categorization next. We will then explain each of these PCNs in more detail and categorize them in Section IV.

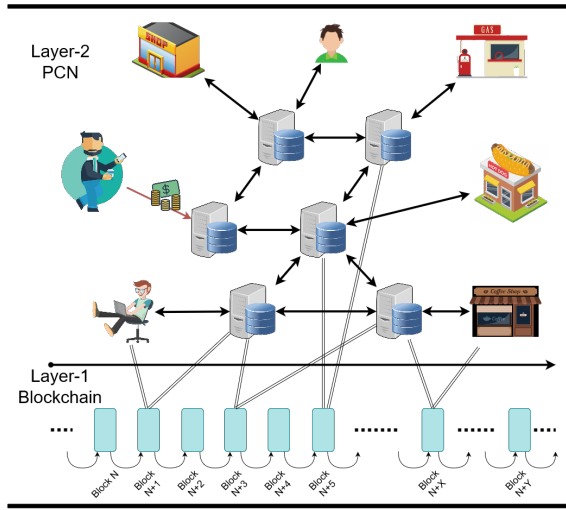

Fig. 2. A PCN of end-users and relays acting as backbone.

## B. PCN Architectures

In this section, we categorize the types of *network architectures* that can be used in PCNs.

1) *Centralized Architecture*: In this type of network, there is a central node, and users communicate with each other either over that central node or based on the rules received from the central node as shown in Fig. 3(a). From the governing point of view, if an organization or a company can solely decide on the connections, capacity changes, and flows in the network, then this architecture is called to be a centralized one.

2) *Distributed Architecture*: In distributed networks, there is no central node. As opposed to the centralized network, each user has the same connectivity, right to connect, and voice in the network. A sample architecture is shown in Fig. 3(b).

3) *Decentralized Architecture*: This type of architecture is a combination of the previous two types which is shown in Fig. 3(c). In this architecture, there is no singular central node, but there are independent central nodes. When the child nodes are removed, central nodes' connections look very much like a distributed architecture. However, when the view is concentrated around one of the central nodes, a centralized architecture is observed.

4) *Federated Architecture*: Federated architecture sounds very much like the federation of the states in the real world and arguably lies somewhere between centralized and decentralized networks. In a federated architecture, there are many central nodes where they are connected to each other in a P2P fashion. Then the remaining nodes (children) strictly communicate with each other over these central nodes which very much looks like a federation of centralized architectures.

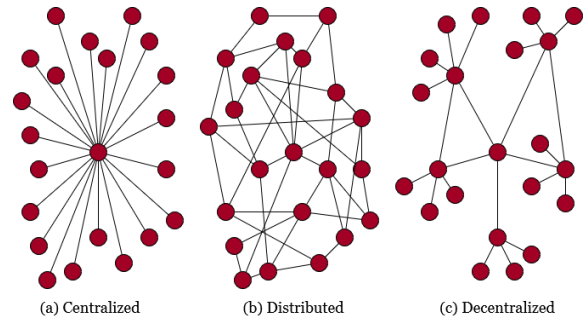

Fig. 3. Network Types

## C. Types of Blockchain Networks

In this section, we categorize the existing PCNs based on blockchain type they employ. There are mainly three types of blockchains employed by PCNs:

1) *Public Blockchain*: In a public blockchain, no binding contract or registration is needed to be a part of the network. Users can join or leave the network whenever they want. Consequently, the PCN will be open to anyone who would like to use it.

2) *Permissioned Blockchain*: Permissioned (i.e., Private) blockchain lays at the opposite side of the public blockchain, where the ledger is managed by a company/organization. Moreover, the roles of the nodes within the network are assigned by the central authority. Not everybody can participate or reach to the resources in the permissioned blockchain. PCNs employing permissioned blockchain will be “members-only”.

3) *Consortium Blockchain*: Contrary to the permissioned blockchain, in consortium blockchain, the blockchain is governed by more than one organization. From the centralization point of view, this approach seems more liberal but the governance model of the blockchain slides it to the permissioned side. PCNs utilizing consortium blockchain will be similar to permissioned blockchain in terms of membership but in this case members will be approved by the consortium.

#### IV. PRIVACY ISSUES IN PCNS: METRICS AND EVALUATION

As PCNs started to emerge within the last few years, a lot of research has been devoted to make them efficient, robust, scalable and secure. However, as some of these PCNs started to be deployed, they reached large number of users (i.e., LN has over 10K users), which is expected to grow further. Such growth brings several privacy issues that are specific to PCNs. We argue that there is a need to identify and understand privacy risks in PCNs from both the users and businesses perspectives. Therefore, in this section, we first define these privacy metrics and explain possible privacy attacks in PCNs. We then summarize the existing PCNs to evaluate their privacy capabilities with respect to these metrics for the first time.

##### A. Privacy in PCNs

In its simplest form, *data privacy* or *information privacy* can be defined as the process which answers how storage, access, and disclosure of data take place. The PCN, in our case, needs to provide services ensuring that the users' data will not be exposed without their authorization. However, the user data travels within the PCN through many other users. To address these issues, some PCN works aimed to hide the sender ( $u_s$ ) or receiver ( $u_r$ ) identity (i.e., *anonymity*) whereas some others concentrated on strengthening the *relationship anonymity* between sender and recipient.

##### B. Attack Model and Assumptions

There are two types of attackers considered in this paper. The first attacker is an *honest-but-curious* (HBC) where the attacker acts honestly while running the protocols but still collects information passively during operations. The second attacker of interest is the *malicious* attacker that controls more than one node in the network to deviate from the protocols. These attacker types and how they can situate in the network are shown in Fig. 4 as follows: ① The attacker is on the path of a payment. ② The attacker is not on the path of a particular payment but it can partially observe the changes in the network. ③ The attacker colludes with other nodes, for example, to make packet timing analysis with sophisticated methods.

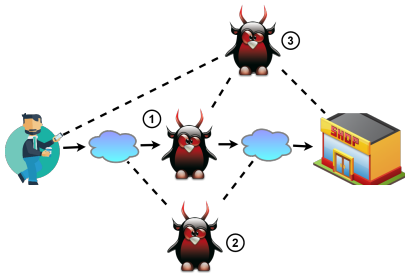

Fig. 4. Attackers can appear in the network in different places.

Based on these assumptions, we consider the following potential attacks for compromising privacy in PCNs:

- **Attacks on Sender/Recipient Anonymity:** Sender/Recipient anonymity requires that the identity of the sender/recipient ( $u_s/u_r$ ) should not be known to the others during a payment. This is to protect the privacy of the sender/recipient so that nobody can track their shopping habits. There may be cases where an adversary may successfully guess the identity of the sender/recipient as follows: For case ①, the sender can have a single connection to the network and next node is the attacker, hence, the attacker is sure that  $u_s$  is sender. For case ② the attacker may guess the sender/recipient by probing the changes in the channel balances. For case ③ the attacker will learn the sender/recipient if it can carry out a payment timing analysis within the partial network formed by the colluded nodes.
- **Attack on Channel Balance Privacy.** To keep the investment power of a user/business private, the channel capacities should be kept private in PCNs. The investment amount in a channel would give hints about financial situation of a user or its shopping preferences. Moreover, if the capacity changes in the channels are known, tracing them causes indirect privacy leakages about the senders/recipients. For instance, an attacker can initiate fake transaction requests. After gathering responses from intermediary nodes, it can learn about the channel capacities.
- **Relationship Anonymity.** In some cases identities of  $u_s$  or  $u_r$  may be known. This is a very valid case for retailers because they have to advertise their identities to receive payments. However, if an attacker can relate the payer to the payee, not only the spending habits of the sender but also the the business model of the recipient will be learned. In such cases, the privacy of the trade can be preserved by hiding the relationship between the sender and recipient. Specifically, who-pays-to-whom information should be kept private.
- **Business Volume Privacy.** For a retailer, publicly disclosed revenue will yield the trade secrets of its business, which must be protected by the PCN. In that sense, privacy of every payments is important. Such payment privacy can be attacked as follows: In a scenario where two or more nodes collude, the amount of a transaction can be known to the attacker. In another scenario, if the recipient is connected to the network via a single channel through the attacker, then it will track all of the flows towards the recipient.

##### C. State-of-the-art PCNs and their Privacy Evaluation

In this section, we briefly describe current studies which either present a complete PCN or propose revisions to the current ones, then analyze their privacy capabilities based on our threat model. We provide a summary of the assessment of the current PCNs' categorizations and privacy features in Table I.

**Lightning Network (LN):** LN [4] is the first deployed PCN which utilizes Bitcoin. It started in 2017 and by June

TABLE I  
QUALITATIVE EVALUATION OF PRIVACY FEATURES OF EXISTING PCNS.

	Network Type	Blockchain Type	Sender Anonymity	Recipient Anonymity	Channel Balance Privacy	Relationship Anonymity	Business Volume Privacy
Lightning Network (HTLC) [4]	Decentralized/ Distributed	Public	●	●	●	●	●
Raiden Network [5]	Decentralized/ Distributed	All	●	●	●	●	●
Spider [?]	Decentralized/ Centralized	All	●	●	○	●	●
SilentWhispers [8]	Decentralized/ Centralized	All	●	●	●	●	●
SpeedyMurmurs [9]	Decentralized/ Centralized	Public	●	●	●	●	●
PrivPay [10]	Decentralized/ Centralized	Permis- sioned	●	●	●	●	●
Bolt [11]	Centralized	Public	●	●	●	●	●
Erdin et al. [12]	Distributed/ Federated	All	●	●	●	●	●
Anonymous Multi-Hop Locks (AMHL) [13]	Decentralized/ Distributed	Public	○	●	●	●	●

- : Partially satisfies OR can not defend against all mentioned attacks.
- : Fully satisfies.
- : Does not satisfy.

2020 serves with more than 12,000 nodes and 36,000 channels. Nodes in LN utilize “*Hashed Time-Locked Contracts*” (HTLC) for multi-hop transfer. The directional capacities in the payment channels are not advertised but the total capacity in the channel is known for a sender to calculate a path. This provides a partial channel balance privacy. The sender encrypts the path by using the public keys of the intermediary nodes by utilizing “*onion-routing*” so that the intermediary nodes only know the addresses of the preceding and the following nodes. None of the intermediary nodes can guess the origin or the destination of the message by looking at the network packet.

**Raiden Network:** Shortly after LN, Ethereum foundation announced Raiden Network [5]. Raiden is the equivalent of LN designed for transferring Ethereum ERC20 tokens and provides the same privacy features. Although Ethereum is the second largest cryptocurrency, that popularity is not reflected well in the Raiden Network. As of June 2020, Raiden serves with 25 nodes and 54 channels. The advantage of Raiden over LN is, due to tokenization, users can generate their own tokens to create a more flexible trading environment.

**Spider Network:** Spider network [7] is a PCN which proposes applying packet-switching based routing idea which is seen in traditional networks (e.g., TCP/IP). However, it is known that in packet-switching the source and the destination of the message should be embedded in the network packet. The payment is split into many micro-payments so that the channel depletion problem gets eliminated. The authors also aimed having better-balanced channels. In this PCN, there are *spider routers* with special functionalities which communicate with each other and know the capacities of the channels in the network. The sender sends the payment to a router. When

the packet arrives at a router, it is queued up until the funds on candidate paths are satisfactory to resume the transaction. The authors do not mention privacy, and plan utilizing onion-routing as a future work. The micro-payments might follow separate paths, which would help keeping business volume private if the recipients were kept private. Additionally, hijack of a router will let an attacker learn everything in the network.

**SilentWhispers:** SilentWhispers [8] utilizes landmark routing where landmarks are at the center of the payments. In their attack model, either the attacker is not on the payment path or a landmark is HBC. Here, landmarks know the topology but they do not know all of the channel balances. When sender wants to send money to a recipient, she/he communicates with the landmarks for her/his intent. Then landmarks start communicating with the possible nodes from “sender-to-landmark” to the “landmark-to-recipient” to form a payment path. Each node in the path discloses the channel balance availability for the requested transfer amount to the landmarks. Then landmarks decide on the feasibility of the transaction by doing multi-party computation. In SilentWhispers, the sender and the receiver are kept private but the landmarks know the sender-recipient pair. The payment amount is also private for the nodes who do not take part in the transaction. Moreover, the balances of the channels within the network are kept private. Although centralization is possible, the approach is decentralized and landmarks are trusted parties.

**SpeedyMurmurs:** SpeedyMurmurs [9] is a routing protocol, specifically an improvement for LN. In SpeedyMurmurs, there are well-known landmarks like in SilentWhispers. The difference of this approach is that the nodes on a candidate path exchange their neighbors’ information anonymously. So if a

node is aware of a path closer to the recipient, it forwards the payment in that direction, called “shortcut path”. In a shortcut path, an intermediary node does not necessarily know the recipient but knows a neighbor close to the recipient. SpeedyMurmurs hides the identities of the sender and the recipient by generating anonymous addresses for them. Intermediary nodes also hide the identities of their neighbors by generating anonymous addresses. Although it may be complex, applying de-anonymization attacks on the network will turn it into SilentWhispers. This is because, while the algorithm is a decentralized approach, with unfair role distribution, it may turn into a centralized approach.

**PrivPay:** PrivPay [10] is a hardware-oriented version of SilentWhispers. The calculations in the landmark are done in tamper-proof trusted hardware. Hence, the security and privacy of the network are directly related to the soundness of the trusted hardware which may also bring centralization. In PrivPay, sender privacy is not considered. Receiver privacy and business volume privacy is achieved by misinformation. When an attacker constantly tries to query data from other nodes the framework starts to produce probabilistic results.

**Bolt:** Bolt [11] is a hub-based payment system. That is, there is only one intermediary node between sender and recipient. Bolt assumes *zero-knowledge proof* based cryptocurrencies. It does not satisfy privacy in multi-hop payments, however, it satisfies very strong relationship anonymity if the intermediary node is honest. On the other hand, being dependant on a single node makes this approach a centralized one.

**Permissioned Bitcoin PCN:** In PCNs, if the network topology is not ideal, e.g., star topology, some of the nodes may learn about the users and payments. To this end, the authors in [12] propose a new topological design for a permissioned PCN such that the channels’ depletion can be prevented. They come up with a real use case where a consortium of merchants create a full P2P topology and the customers connect to this PCN through merchants which undertakes the financial load of the network to earn money. The privacy of the users in the PCN is satisfied by LN-like mechanisms. The authors also investigate how initial channel balances change while the sender/receiver privacy and the relationship anonymity can be satisfied by enforcing at least 3-hops in a multi-hop payment.

**Anonymous Multi-Hop Locks (AMHL):** In AMHL proposal [13], the authors offer a new HTLC mechanism for PCNs. On a payment path, the sender agrees to pay some service fee to each of the intermediaries for their service. However, if two of these intermediaries maliciously collude they can eliminate honest users in the path and consequently steal their fees. In order to solve this, they introduce another communication phase in which the sender distributes a one-time-key to the intermediary nodes. Although the HTLC mechanism is improved for the security of the users the sender’s privacy is not protected; each of the intermediaries learns the sender. However, relationship anonymity can still be satisfied.

## V. FUTURE RESEARCH ISSUES IN PCNS

Privacy in PCNs is an understudied topic and there are many open issues that need to be addressed as a future research. In this section, we summarize these issues:

**Abuse of the PCN protocols.** As most of the PCNs rely on public cryptocurrencies, whose protocol implementations are public. This freedom can be abused such that by changing some parameters and algorithms in the design, an attacker can behave differently than what is expected. This will bring privacy leakages and censorship in the network. A topological reordering of the network will help solve this problem. If a sender gets suspicious about an intermediary node, it can look for alternatives instead of using that node.

**Discovery of Colluding Nodes.** When the nodes collude in a PCN, they can extract more information about the users. To prevent this, the protocols should be enriched to discover the colluding nodes or by adding redundancy to the protocols, colluding nodes can be confused.

**Policy Development.** The cryptocurrency and PCN idea is still in the early phases of their lives. Hence, policy and regulation for not only the security of the participants but also for the privacy of them is highly needed in this domain. This will also create a quantitative metric for the researchers to measure the success of their proposals.

**Impact of Scalability on Privacy.** One of the aims for introducing PCNs was making the cryptocurrencies more scalable. For example, LN advises running the Barabasi-Albert scale-free network model while establishing new connections [15]. Thus, the final state of the network can impose centralization which will have adverse effects on the privacy of the nodes in the network.

**Integration of IoTs with PCNs.** Use of IoT devices for payments are inevitable. Aside from the fact that most IoT devices are not powerful to run a full node, security and privacy of the payments and the device identities within the IoT ecosystem needs to be studied. These devices are anticipated to be able to participate in the network through gateways. Revelation of device ownership will reveal the real identity of the users to the public which is a big threat on privacy.

**Privacy in Permissioned PCNs.** While establishing a network of merchants in permissioned PCNs, the merchants should at least disclose their expected trade volume in order to establish a dependable network. This will, however, yield trade secrets of the merchants. To prevent this, zero-knowledge proof based multi-party communication can be explored.

## VI. CONCLUSION

PCN is a promising solution to make the cryptocurrency-based payments scalable. This idea aimed fixing two major shortcomings of the cryptocurrencies: long confirmation times and high transaction fees. There are many studies on the design of payment channels and PCNs to make the transfers secure and efficient. However, these studies do not mention the possible privacy leakages of these methods in case of a wide adaptation of proposed ideas. In this paper, we first made the

categorization of PCNs based on the type of blockchain being used and the topological behavior of the network. After clearly defining possible privacy leakages in a PCN, we compared and contrasted the state-of-the-art PCN approaches from the privacy point of view.

## REFERENCES

- [1] Satoshi Nakamoto et al. Bitcoin: A peer-to-peer electronic cash system. 2008.
- [2] Ujan Mukhopadhyay, Anthony Skjellum, Oluwakemi Hambolu, JonOakley, Lu Yu, and Richard Brooks. A brief survey of cryptocurrencies systems. In 2016 14th annual conference on privacy, security and trust (PST), pages 745–752. IEEE, 2016.
- [3] Florian Tschorsch and Bjorn Scheuermann. Bitcoin and beyond: A technical survey on decentralized digital currencies. *IEEE Communications Surveys Tutorials*, 18(3):2084–2123, 2016.
- [4] Joseph Poon and Thaddeus Dryja. The bitcoin lightning network: Scalable off-chain instant payments, 2016.
- [5] Raiden Network: Fast, cheap, scalable token transfers for Ethereum. <https://raiden.network/>. Accessed: 2020-06-06.
- [6] Shehar Bano, Alberto Sonnino, Mustafa Al-Bassam, Sarah Azouvi, Patrick McCorry, Sarah Meiklejohn, and George Danezis. Sok: Consensus in the age of blockchains. In *Proceedings of the 1st ACM Conference on Advances in Financial Technologies*, pages 183–198, 2019.
- [7] Vibhaalakshmi Sivaraman, Shaileshh Bojja Venkatakrishnan, Kathy Ruan, Parimarjan Negi, Lei Yang, Radhika Mittal, Mohammad Alizadeh, and Giulia Fanti. High throughput cryptocurrency routing in payment channel networks, 2018.
- [8] Giulio Malavolta, Pedro Moreno-Sanchez, Aniket Kate, and Matteo Maffei. Silentwhispers: Enforcing security and privacy in decentralized credit networks. In *NDSS*, 2017.
- [9] Stefanie Roos, Pedro Moreno-Sanchez, Aniket Kate, and Ian Goldberg. Settling payments fast and private: Efficient decentralized routing for path-based transactions. *arXiv preprint arXiv:1709.05748*, 2017.
- [10] Pedro Moreno-Sanchez, Aniket Kate, Matteo Maffei, and Kim Pecina. Privacy preserving payments in credit networks. In *Network and Distributed Security Symposium*, 2015.
- [11] Matthew Green and Ian Miers. Bolt: Anonymous payment channels for decentralized currencies. In *Proceedings of the 2017 ACM SIGSAC Conference on Computer and Communications Security*, pages 473–489, 2017.
- [12] Enes Erdin, Mumin Cebe, Kemal Akkaya, Senay Solak, Eyuphan Bulut, and Selcuk Uluagac. A bitcoin payment network with reduced transaction fees and confirmation times. *Computer Networks*, page 107098, 2020.
- [13] Giulio Malavolta, Pedro Moreno-Sanchez, Clara Schneidewind, Aniket Kate, and Matteo Maffei. Anonymous multi-hop locks for blockchains scalability and interoperability. In *NDSS*, 2019.
- [14] Vibhaalakshmi Sivaraman, Shaileshh Bojja Venkatakrishnan, Mohammad Alizadeh, Giulia Fanti, and Pramod Viswanath. Routing cryptocurrency with the spider network. In *Proceedings of the 17th ACM Workshop on Hot Topics in Networks*, pages 29–35, 2018.
- [15] Stefano Martinazzi and Andrea Flori. The evolving topology of the lightning network: Centralization, efficiency, robustness, synchronization, and anonymity. *Plos one*, 15(1):e0225966, 2020.