

# Privacy-Preserving Distributed Optimal Power Flow with Partially Homomorphic Encryption

Tong Wu, *Student Member, IEEE*, Changhong Zhao, *Member, IEEE* and Ying-Jun Angela Zhang, *Fellow, IEEE*

**Abstract**—Distribution grid agents are obliged to exchange and disclose their states explicitly to neighboring regions to enable distributed optimal power flow dispatch. However, the states contain sensitive information of individual agents, such as voltage and current measurements. These measurements can be inferred by adversaries, such as other participating agents or eavesdroppers, leading to the privacy leakage problem. To address the issue, we propose a privacy-preserving distributed optimal power flow (OPF) algorithm based on partially homomorphic encryption (PHE). First of all, we exploit the alternating direction method of multipliers (ADMM) to solve the OPF in a distributed fashion. In this way, the dual update of ADMM can be encrypted by PHE. We further relax the augmented term of the primal update of ADMM with the  $\ell_1$ -norm regularization. In addition, we transform the relaxed ADMM with the  $\ell_1$ -norm regularization to a semidefinite program (SDP), and prove that this transformation is exact. The SDP can be solved locally with only the sign messages from neighboring agents, which preserves the privacy of the primal update. At last, we strictly prove the privacy preservation guarantee of the proposed algorithm. Numerical case studies validate the effectiveness and exactness of the proposed approach. In particular, the case studies show that the encrypted messages cannot be inferred by adversaries. Besides, the proposed algorithm obtains the solutions that are very close to the global optimum, and converges much faster compared to competing alternatives.

**Index Terms**—Distributed Optimal Power Flow, Privacy Preservation, Partially Homomorphic Encryption.

## NOMENCLATURE

### Sets

$\mathcal{N}$	The set of all buses.
$\mathcal{M}$	The set of all edges.
$\mathcal{N}^g$	The set of generation buses.
$\mathcal{R}_r$	The set of buses assigned to region $r$ .
$\mathcal{B}_r$	The joint set including the buses in $\mathcal{R}_r$ and the buses duplicated from the neighboring regions that are directly connected to the buses in $\mathcal{R}_r$ .
$\mathcal{N}^{\delta(r)}$	The set of neighboring regions for region $r$ .
$\mathcal{F}_r^{\mathbb{C}}$	The feasible set of the OPF problem in region $r$ in the complex domain.
$\mathcal{F}_r^{\mathbb{R}}$	The feasible set of the OPF problem in region $r$ in the real domain.

### Abbreviation

ADMM	Alternating direction method of multipliers.
------	--

T. Wu, C. Zhao, Y.-J. A. Zhang are with the Department of Information Engineering, The Chinese University of Hong Kong, Shatin, New Territories, Hong Kong (Email: {wt017, chzhao, yjzhang}@ie.cuhk.edu.hk).

This work was supported in part by General Research Funding (Project number 14208017, Project number 14201920) and Early Career Award No. 24210220 from the Research Grants Council of Hong Kong, CUHK Research Incentive Scheme No. 4442755 and CUHK Direct Grant No. 4055128.

OPF	Optimal Power Flow.
DOPF	Distributed Optimal Power Flow.
PHE	Partially homomorphic encryption.
SDP	Semidefinite Program.
PPOPF	Privacy-Preserving Distributed Optimal Power Flow.

### Variables

$P_{G_i}$	The active power by generators at bus $i$ .
$Q_{G_i}$	The reactive power by generators at bus $i$ .
$V_i$	The complex voltage at bus $i$ .
$\mathbf{v}$	The vector of complex bus voltages.
$\mathbf{W}$	The square matrix of $\mathbf{v}$ .
$\mathbf{X}$	The real part of $\mathbf{W}$ .
$\mathbf{Z}$	The imaginary part of $\mathbf{W}$ .
$\mathbf{W}^r$	The sub-matrix of $\mathbf{W}$ restricted to $\mathcal{B}_r$ .
$\mathbf{X}^r$	The sub-matrix of $\mathbf{X}$ restricted to $\mathcal{B}_r$ .
$\mathbf{Z}^r$	The sub-matrix of $\mathbf{Z}$ restricted to $\mathcal{B}_r$ .
$\mathbf{W}_l^r$	The sub-matrix of $\mathbf{W}$ restricted to $\mathcal{B}_r \cap \mathcal{B}_l$ (variables for region $r$ ).
$\mathbf{X}_l^r$	The sub-matrix of $\mathbf{X}$ restricted to $\mathcal{B}_r \cap \mathcal{B}_l$ (variables for region $r$ ).
$\mathbf{Z}_l^r$	The sub-matrix of $\mathbf{Z}$ restricted to $\mathcal{B}_r \cap \mathcal{B}_l$ (variables for region $r$ ).
$\Gamma_l^r$	The dual variable matrix corresponding to $\mathbf{X}_l^r$ .
$\Lambda_l^r$	The dual variable matrix corresponding to $\mathbf{Z}_l^r$ .
$\mathbf{X}_{l,o}^r$	An element of $\mathbf{X}_l^r$ .
$\mathbf{Z}_{l,o}^r$	An element of $\mathbf{Z}_l^r$ .
$\mathbf{X}$	A block diagonal matrix, defined in (42)-(49).

### Constants

$a_j, b_j,$	Coefficients of the quadratic production cost function of unit $j$ .
$c_j$	
$\mathbf{Y}_i, \bar{\mathbf{Y}}_i, \mathbf{M}_i$	The constructed matrices based on $Y$ at bus $i$ .
$P_{D_i}$	The active power demand at bus $i$ .
$Q_{D_i}$	The reactive power demand at bus $i$ .
$Y$	Nodal admittance matrix.
$Y_{ij}$	The $(i, j)$ th element of $Y$ .
$\bar{P}_{G_i}$	The upper bound of $P_{G_i}$ .
$\underline{P}_{G_i}$	The lower bound of $P_{G_i}$ .
$\bar{Q}_{G_i}$	The upper bound of $Q_{G_i}$ .
$\underline{Q}_{G_i}$	The lower bound of $Q_{G_i}$ .
$\bar{V}_i$	The upper bound of voltage magnitude $ V_i $ .
$\underline{V}_i$	The lower bound of voltage magnitude $ V_i $ .
$\mathbf{W}_r^l$	The communication message that is a sub-matrix of $\mathbf{W}$ restricted to $\mathcal{B}_r \cap \mathcal{B}_l$ (constants for agent $r$ ).

$\mathbf{X}_r^l$	The communication message that is a submatrix of $\mathbf{X}$ restricted to $\mathcal{B}_r \cap \mathcal{B}_l$ (constants for agent $r$ ).
$\mathbf{Z}_r^l$	The communication message that is a submatrix of $\mathbf{Z}$ restricted to $\mathcal{B}_r \cap \mathcal{B}_l$ (constants for agent $r$ ).
$\mathbf{G}_i^r, \bar{\mathbf{G}}_i^r$	The real part of $\mathbf{Y}_i, \bar{\mathbf{Y}}_i$ .
$\mathbf{B}_i^r, \bar{\mathbf{B}}_i^r$	The imaginary part of $\mathbf{Y}_i, \bar{\mathbf{Y}}_i$ .

## I. INTRODUCTION

### A. Background and Motivation

With the increasing observability of power systems, the system operators carry out advanced operational practices to steer the system towards an optimal power flow (OPF) solution [1, 2]. In particular, when the synchronized measurements from different buses are transferred to the system operator, the sensitive information, such as voltage and current measurements, is likely to expose distribution grid buses to privacy breaches [3]. Several studies have shown that the high-resolution measurements of OPF variables can be used by adversaries to infer the users' energy consumption patterns and types of appliances [4, 5].

To reduce the global communication of different buses, distributed algorithms have been proposed to solve OPF, where only boundary variables are shared among agents that act as independent system operators in different regions [6–11]. In these works, one classical approach is alternating direction method of multipliers (ADMM) [6–8]. In particular, Reference [7] applied the ADMM to the semidefinite program (SDP) relaxation of OPF problem. Then, [8] solved the general form of OPF problems using ADMM in a distributed way, where the complex voltages on the boundary buses are shared with neighboring agents. Similarly, the OPF problem has been relaxed as a second order cone program (SOCP), and then solved in a distributed way by ADMM [6]. Noticeably, the complex power flow measurements in [6] are transferred to neighboring agents. Another distributed approach is dual decomposition [11, 12]. Reference [12] proposed a dual algorithm to coordinate the subproblems decomposed from the SDP relaxation of OPF problem. In [11], the decomposed subproblem can be solved with a closed-form solution. Meanwhile, the solutions of the subproblems need to be communicated between each pair of agents iteratively, resulting in large privacy leakage. Other methods include the multiplier methods [9, 10], where the buses are required to exchange their states directly in the communication network.

To achieve or approximate the optimal solution in the above distributed algorithms, agents inevitably need to share their individual information with their neighbors, which leads to serious privacy leakage problems. For example, the direct communication among buses gives adversaries or eavesdroppers a chance to launch the cyber attack on the grid system effectively [13]. In particular, adversaries are able to design the optimal attack to increase the generation costs or disturb the electricity market [5]. Therefore, it is desirable to design privacy-preserving distributed OPF (DOPF) algorithms.

### B. Related Works

Recently, some privacy-preserving methods have been proposed to solve distributed optimization problems. These methods are broadly classified into two categories, namely differential-privacy methods [14–16] and homomorphic encryption methods [17–19]. In particular, differential-privacy methods introduce a random perturbation to the shared messages to protect an agent's privacy [14]. In power systems, [15] optimized OPF variables as affine functions of the random noise. In addition, [16] introduced the OPF Load Indistinguishability (OLI) problem, which guarantees load data privacy while achieving a feasible and near optimal energy dispatch. In [15], a differential privacy method has been proposed to protect OPF variables. Note that there is an inevitable trade-off between optimality and privacy in differential-privacy methods, due to the random perturbation added to the shared messages.

As to the homomorphic encryption methods, [17] studied how a system operator and a set of agents securely execute a distributed projected gradient-based algorithm. In [18, 19], the projected gradient-based algorithm and ADMM algorithm were incorporated with the partially homomorphic encryption scheme (PHE) to facilitate the privacy-preserving distributed optimization. In [20], a PHE-based method has been proposed to estimate states securely. In addition, [21] applies the PHE to the cloud-based quadratic optimization problem. However, these methods are applicable only when the optimization problems are unconstrained or a closed-form primal update is available. Therefore, the above methods are not applicable to the OPF problems directly.

### C. Contributions

To address the challenges mentioned above, we are motivated to develop a privacy-preserving DOPF method based on partially homomorphic encryption. To enable the cryptographic techniques in DOPF, we first apply a sequence of strong SDP relaxations to the OPF problem. Then, we decouple the centralized SDP into multiple small-scale SDPs with boundary constraints. In this way, the ADMM method is employed to solve multiple SDPs in a distributed fashion. In particular, we protect the privacy of both primal and dual updates of ADMM based on PHE. Our main contributions are summarized as follows.

- We develop a privacy-preserving distributed optimal power flow method based on PHE. To the best of our knowledge, this is the first time that cryptographic techniques are incorporated in the distributed AC optimal power flow problem. Compared with differential-privacy based optimization methods, our approach obtains the solutions that are very close to the global optimum, and converges faster. In addition, our approach can preserve the privacy of gradients and intermediate primal states.
- To solve the primal update problem securely, we relax the augmented terms in ADMM by the  $\ell_1$ -norm regularization. We further transform the new primal update

problem as an SDP problem, which only shares the sign information with other agents. In addition, the privacy of the dual update of ADMM is protected by PHE with random penalty parameters. In comparison to the traditional ADMM that exposes agents' intermediate states to privacy breaches, the proposed ADMM protects the privacy of both primal and dual updates of ADMM. The difference between the traditional ADMM and proposed method is summarized in Table I.

- We rigorously prove the privacy preservation of the proposed algorithm with two commonly encountered types of adversaries. For honest-but-curious agents, our analysis shows that the privacy information of neighboring agents cannot be inferred from the shared messages. Likewise, we prove that external eavesdroppers cannot infer the privacy of exchanged information. In contrast, other PHE-based algorithms cannot protect the primal update of ADMM if the primal problem is constrained.

TABLE I: Traditional ADMM VS Privacy-Preserving ADMM

Traditional ADMM	Privacy-Preserving ADMM
Frobenius norm	$\ell_1$ -norm
Synchronized	Asynchronized
Privacy leakage	Privacy preservation

#### D. Organization and Overview

The rest of the paper is organized as follows. In Section II, we introduce the preliminaries of the OPF problem and Paillier cryptosystem. In Section III, we present the privacy-preserving distributed optimal power flow method. In Section IV, we strictly prove the privacy preservation guarantee of the proposed algorithm. The case studies are given in Section V. Finally, we conclude the paper in Section VI.

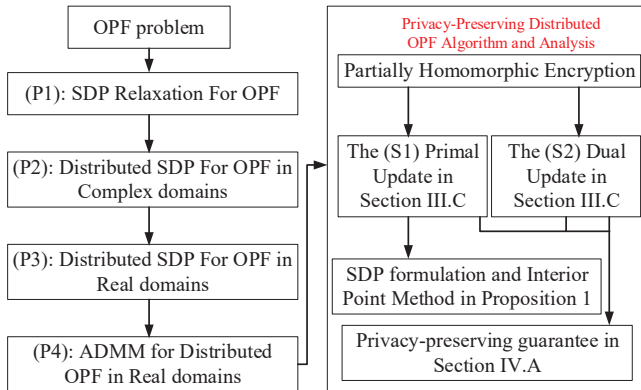

Fig. 1: The overview of the proposed method.

The schematic overview of the methodology in the paper is shown in Fig. 1. We first review the OPF problem (P1), and then transform it into the SDP problem both in complex domains and real domains, i.e., Problem (P2) and Problem (P3). Furthermore, we equivalently transform (P3) into the distributed formulation, and further employ the ADMM method for the DOPF problem in (P4). The ADMM method is relaxed by the  $\ell_1$ -norm regularization. As such, we develop the (S1) primal update and the (S2) dual update in the relaxed ADMM

method. In the process, both the (S1) primal update and the (S2) dual update are encrypted by the Partially Homomorphic Encryption scheme. In particular, the (S1) primal update is formulated as an SDP problem, and then solved by the interior-point method, elaborated in Proposition 1 and Appendix. At last, we provide the mathematical proof for the privacy-preserving guarantee in Section IV.A.

## II. PRELIMINARIES

### A. Definition

It is worth noticing that privacy has different meanings for different applications. For example, privacy has been defined as the non-disclosure of agent's states [17, 18], gradients or sub-gradients [15, 16]. In this paper, we define privacy as the non-disclosure of agents' intermediate states and gradients of the objective functions. Noticeably, agents' intermediate states are feasible solutions to power flow equations in corresponding regions. Besides, power flow equations can be regarded as a mapping function from intermediate states to the system information. Therefore, the parameters and topologies of sub-regions can be inferred by data mining tools from a long-term observation of agents' intermediate states [22]. In general, distributed algorithms usually take multiple iterations to converge, which generates massive intermediate states that enable adversaries to infer the grid models effectively. Likewise, the objective parameters can be inferred from agents' intermediate states and gradients of the objective functions in the same way. In addition, undetectable attacks can be designed by partial observations of agents' intermediate states [23]. During this process, to make an attack undetectable, adversaries should successively inject false data into agents' intermediate states, since only injecting false data into the final states can be easily detected. Therefore, if unprotected, agents' intermediate states could be obtained by adversaries to attack the power grids or disturb the electricity market.

We also define two kinds of adversaries: honest-but-curious agents and external eavesdroppers [19]. Honest-but-curious agents are the agents that follow all protocol steps but are curious and collect all the intermediate states of other participating agents. External eavesdroppers are adversaries who steal information through eavesdropping all the communication channels and exchanged messages between agents. The differences between honest-but-curious agents and external eavesdroppers are:

- honest-but-curious agents only obtain information from the neighboring agents, while external eavesdroppers obtain all agents' shared information;
- honest-but-curious agents can decrypt the shared encrypted information, but external eavesdroppers cannot.

Preserving the privacy of agents' intermediate states can prevent eavesdroppers from inferring any information in optimization.

## B. Optimal Power Flow

We represent the power network by a graph  $\mathcal{G}(\mathcal{N}, \mathcal{M})$ , with vertex set  $\mathcal{N}$  and edge set  $\mathcal{M}$ . We consider the following OPF optimization problem [24]:

$$\min_{P_{G_i}, Q_{G_i}, V_i} C(P_{G_i}) = \sum_{i=1}^{|\mathcal{N}^g|} a_i P_{G_i}^2 + b_i P_{G_i} + c_i, \quad (1a)$$

$$\text{s.t.} \quad P_{G_i} - P_{D_i} = \text{Re}\{V_i \sum_{j \in \delta(i)} (Y_{ij} V_j)^*\}, i \in \mathcal{N}, \quad (1b)$$

$$Q_{G_i} - Q_{D_i} = \text{Im}\{V_i \sum_{j \in \delta(i)} (Y_{ij} V_j)^*\}, i \in \mathcal{N}, \quad (1c)$$

$$\underline{V}_i \leq |V_i| \leq \bar{V}_i, i \in \mathcal{N}, \quad (1d)$$

$$\underline{P}_{G_i} \leq P_{G_i} \leq \bar{P}_{G_i}, i \in \mathcal{N}, \quad (1e)$$

$$\underline{Q}_{G_i} \leq Q_{G_i} \leq \bar{Q}_{G_i}, i \in \mathcal{N}. \quad (1f)$$

where  $Y$  is the nodal admittance matrix and  $\delta(i)$  is the set of neighboring buses of node  $i$ . The objective function (1a) describes the fuel cost.  $a_i$ ,  $b_i$  and  $c_i$  are nonnegative coefficients. Note that  $\mathcal{N}^g$  is the set of generator buses and  $|\mathcal{N}^g|$  is its cardinality.  $V_i$  is the complex voltage on bus  $i$  with magnitude  $|V_i|$  and phase  $|\theta_i|$ . The constraints in (1b) and (1c) describe the power flow equations on each bus  $i$ . The active power output  $P_{G_i}$  and reactive power output  $Q_{G_i}$  of generator  $i$  and the voltage magnitude  $|V_i|$  are bounded in Eqs. (1d)-(1f) by constant bounds  $\underline{P}_{G_i}$ ,  $\bar{P}_{G_i}$ ,  $\underline{Q}_{G_i}$ ,  $\bar{Q}_{G_i}$ ,  $\underline{V}_i$  and  $\bar{V}_i$ . In addition, we enforce  $\underline{P}_{G_i} = 0$ ,  $\bar{P}_{G_i} = 0$ ,  $\underline{Q}_{G_i} = 0$  and  $\bar{Q}_{G_i} = 0$  for non-generator buses  $\mathcal{N}/\mathcal{N}^g$ . Problem (1) is a non-convex problem because of the nonconvexity of constraints (1b)-(1c).

## C. Partially Homomorphic Encryption

In this subsection, we introduce cryptosystem, which will be used to enable privacy-preserving DOPF in the following section. The Paillier cryptosystem is a public-key system consisting of three parts, i.e., key generation, encryption and decryption [25]. In particular, we have the public key and private key in the key generation stage. The public key are disseminated to all agents to encrypt messages. The private key is only known to one agent or the system operator and used to decrypt messages. In particular, both the private key and the public key are time-varying. As shown in Algorithm 1, the three parts of Paillier cryptosystem are implemented by three functions, i.e., **Keygen**( $\cdot$ ),  $c = \mathcal{E}(m)$  and  $m = \mathcal{D}(c)$ .

Noticeably, the Paillier system is additively homomorphic. In particular, the ciphertext of  $m_1 + m_2$  can be obtained from the ciphertexts of  $m_1$  and  $m_2$  directly. We have

$$\mathcal{E}(m_1) * \mathcal{E}(m_2) = \mathcal{E}(m_1 + m_2), \quad (2)$$

$$\mathcal{E}(m)^k = \mathcal{E}(km), k \in \mathbb{Z}^+, \quad (3)$$

where  $m_1$  and  $m_2$  are the original messages, and  $c_1$  and  $c_2$  are the ciphertext of  $m_1$  and  $m_2$ , respectively.

---

## Algorithm 1: Paillier cryptosystem

---

```

1 Function Keygen ( $\cdot$ )
   Output: Public key  $k_p: (n, g)$ , Private key  $k_s: (\lambda, \mu)$ 
2   Choose two large prime numbers  $p$  and  $q$  of equal
   bit-length and compute  $n = p \cdot q$ ;
3    $g \leftarrow n + 1$ ;
4    $\lambda = \phi(n) = (p - 1) \cdot (q - 1)$ , where  $\phi(\cdot)$  denotes the
   Euler's totient function;
5    $\mu = \phi^{-1}(n) \bmod n$ , which is the modular multiplicative
   inverse of  $\phi(n)$ ;
6 Function  $\mathcal{E}(m)$ 
   Output: Ciphertext  $c$ 
7   Choose a random  $r \in \mathbb{Z}_n^* = \{z | z \in \mathbb{Z}, 0 \leq z < n, \text{gcd}(z, n) = 1\}$ ;
8   Generate the ciphertext by  $c = g^m \cdot r^n \bmod n^2$ , where
    $m \in \mathbb{Z}_n = \{z | z \in \mathbb{Z}, 0 \leq z < n\}$ ,  $c \in \mathbb{Z}_{n^2}^*$ ;
9 Function  $\mathcal{D}(c)$ 
   Output: Message  $m$ 
10  Define the integer division function  $L(\mu) = \frac{\mu-1}{n}$ ;
11  Generate the plaintext as  $m = L(c^\lambda \bmod n^2) \cdot \mu \bmod n$ ;

```

---

## III. PRIVACY-PRESERVING DISTRIBUTED OPTIMAL POWER FLOW

### A. Convex Relaxation

To deal with the nonconvexity of Problem (1), we apply SDP relaxation in this subsection.

Let  $\mathbf{v}$  define the vector of complex bus voltages  $\mathbf{v} = (|V_1| \angle \theta_1, \dots, |V_N| \angle \theta_N)$ , where  $N$  denotes the number of buses. We define variable matrix  $\mathbf{W} = \mathbf{v}\mathbf{v}^H$ . We use the notation  $\text{Tr}\{\mathbf{X}\}$  to represent the trace of an arbitrary square matrix  $\mathbf{X}$ . Recall that  $Y$  is the admittance matrix. For  $i \in \mathcal{N}$ ,  $e_i$  is the  $i$ th basis vector in  $\mathbb{R}^N$ ,  $e_i^T$  is its transpose, and  $Y_i = e_i e_i^T Y$ . We define  $\mathbf{Y}_i = 1/2(Y_i^H + Y_i)$ ,  $\bar{\mathbf{Y}}_i = 1/2\sqrt{-1}(Y_i^H - Y_i)$  and  $\mathbf{M}_i = e_i e_i^T$ . Then, we have  $P_{G_i} = \text{Tr}\{\mathbf{Y}_i \mathbf{W}\} + P_{D_i}$ .

The active and reactive power balance equations Eq. (1b) and Eq. (1c) can be combined with constraints (1e) and (1f) as

$$\underline{P}_{G_i} \leq P_{G_i} = \text{Tr}\{\mathbf{Y}_i \mathbf{W}\} + P_{D_i} \leq \bar{P}_{G_i}, \quad (4)$$

$$\underline{Q}_{G_i} \leq Q_{G_i} = \text{Tr}\{\bar{\mathbf{Y}}_i \mathbf{W}\} + Q_{D_i} \leq \bar{Q}_{G_i}, \quad (5)$$

Moreover, Eq. (1d) can be transformed to

$$(\underline{V}_i)^2 \leq \text{Tr}\{\mathbf{M}_i \mathbf{W}\} \leq (\bar{V}_i)^2. \quad (6)$$

As such, we can write an equivalent form of Problem (1) as follows

$$\text{(P1)} : \quad \min \quad C(P_{G_i}) = \sum_{i=1}^{|\mathcal{N}^g|} a_i P_{G_i}^2 + b_i P_{G_i} + c_i, \quad (7a)$$

$$\text{s.t.} \quad (4)-(6), \quad (7b)$$

$$\mathbf{W} \text{ is hermitian, } \mathbf{W} \succeq 0, \quad (7c)$$

$$\text{rank}(\mathbf{W}) = 1, \quad (7d)$$

where the rank-1 constraint in (7d) makes the problem nonconvex. A convex SDP relaxation of (7) is obtained by removing the rank constraint (7d). By Theorem 9 of [26], when the cost function is convex and the network is a tree, the SDP relaxation is exact under mild technical conditions.

### B. Distributed Formulation

Let  $R$  be the total number of regions and  $\mathcal{R}_r$  be the set of buses assigned to region  $r$  with  $\mathcal{R}_r \cap \mathcal{R}_l = \emptyset, \forall l \neq r$  and  $\sum_{r=1}^R |\mathcal{R}_r| = |\mathcal{N}|$ . Let  $\mathcal{B}_r$  denote the joint set including the buses in  $\mathcal{R}_r$  and the buses duplicated from the neighboring regions that are directly connected to the buses in  $\mathcal{R}_r$ . Here, the set of neighboring regions for region  $r$  can be expressed as  $\mathcal{N}^{\delta(r)} = \{l | \mathcal{B}_r \cup \mathcal{B}_l \neq \emptyset\}$ . Finally, we stack the complex voltages of the nodes in  $\mathcal{B}_r$  as  $\mathbf{v}^r$ , i.e.,  $\{V_i\}_{i \in \mathcal{B}_r}$ .

In addition,  $\mathbf{W} = \mathbf{X} + \sqrt{-1}\mathbf{Z}$ , where  $\mathbf{X}$  is the real part of  $\mathbf{W}$  and  $\mathbf{Z}$  is the imaginary part of  $\mathbf{W}$ . Moreover, we define  $\mathbf{Y}_i^r, \bar{\mathbf{Y}}_i^r, \mathbf{M}_i^r, \mathbf{W}^r, \mathbf{X}^r$  and  $\mathbf{Z}^r$  as the sub-matrices of  $\mathbf{Y}_i, \bar{\mathbf{Y}}_i, \mathbf{M}_i, \mathbf{W}, \mathbf{X}$  and  $\mathbf{Z}$ , respectively. In particular, these sub-matrices are formed by extracting rows and columns corresponding to the nodes in  $\mathcal{B}_r$ . Next,  $\mathcal{P}_{rl}$  indexes voltages at the buses shared by  $\mathcal{B}_r$  and  $\mathcal{B}_l$ . For example, if region 1 and region 2 share nodes  $n = 3$  and  $n = 4$ , then  $\mathcal{P}_{12}$  indexes the voltage  $\{V_3\}$  and  $\{V_4\}$ . In addition, let  $\mathbf{W}_l^r$  denote the submatrix of  $\mathbf{W}^r$ , which collects the rows and columns of  $\mathbf{W}^r$  corresponding to the voltages in  $\mathcal{P}_{rl}$ . As such, we rewrite problem (P1) (after rank relaxation) in the following equivalent form:

$$(P2) : \min \sum_{r=1}^R C^r(P_G^r) = \sum_{r=1}^R \left( \sum_{i=1}^{|\mathcal{R}_r^g|} a_i P_{G_i}^2 + b_i P_{G_i} + c_i \right), \quad (8a)$$

$$\text{s.t.} \quad \{\mathbf{W}^r, P_G^r, Q_G^r\} \in \mathcal{F}_r^C, \forall r = 1, \dots, R, \quad (8b)$$

$$\mathbf{W}_l^r = \mathbf{W}_r^l, l \in \mathcal{N}^{\delta(r)}, r = 1, \dots, R, \quad (8c)$$

$$\mathbf{W}^r \succeq 0, \forall r = 1, \dots, R, \quad (8d)$$

where  $P_G^r$  and  $Q_G^r$  denote the entire vectors of  $P_{G_i}$  and  $Q_{G_i}$   $\forall i \in \mathcal{B}_r$  respectively,  $\mathcal{F}_r^C$  in constraint (8b) denotes the feasible set (4)-(6) restricted to buses  $\mathcal{B}_r$ . Besides, constraint (8c) enforces neighboring areas to consent on the entries of  $\mathbf{W}^r$  and  $\mathbf{W}^l$  that they have in common.  $\mathcal{R}_r^g$  denotes the set of generator buses in  $\mathcal{R}_r$ , and  $|\mathcal{R}_r^g|$  denotes the number of generator buses in  $\mathcal{R}_r$ . We denote the real and imaginary part of  $\mathbf{W}_l^r$  by  $\mathbf{X}_l^r$  and  $\mathbf{Z}_l^r$ , respectively. Note that  $\mathbf{W}_r^l$  is the message that is transferred from region  $l$  to region  $r$ . To enforce the equivalence of  $\mathbf{W}_l^r$  and  $\mathbf{W}_r^l$ , we have  $\mathbf{X}_l^r = \mathbf{X}_r^l$  and  $\mathbf{Z}_l^r = \mathbf{Z}_r^l$ . We also denote the number of buses in  $\mathcal{B}_r$  by  $\bar{N}_r = |\mathcal{B}_r|$  and the number of buses in  $\mathcal{B}_r \cap \mathcal{B}_l$  by  $\bar{N}_{rl} = |\mathcal{B}_r \cap \mathcal{B}_l|$ .

The main challenge to this decomposition is the positive semi-definite (PSD) constraints (7c). Indeed, all sub-matrices  $\mathbf{W}^r \succeq 0, \forall r$  does not necessarily imply  $\mathbf{W} \succeq 0$ . Luckily, as established in [27],  $\mathbf{W}^r \succeq 0$  for all region  $r$  is equivalent to  $\mathbf{W} \succeq 0$  if the following assumption holds.

- Every maximal clique is contained in the subgraph formed by  $\mathcal{B}_r$  for at least one  $r$ .

When the network is a tree, every pair of adjacent nodes connected by an edge forms a maximal clique, and thus this assumption is trivially true.

Let  $\mathbf{G}_i^r$  denote the real part and  $\mathbf{B}_i^r$  denote the imaginary part of  $\mathbf{Y}_i^r$ . Let  $\bar{\mathbf{G}}_i^r$  denote the real part and  $\bar{\mathbf{B}}_i^r$  denote the imaginary part of  $\bar{\mathbf{Y}}_i^r$ . We have

$$\begin{aligned} \text{Tr}\{\mathbf{Y}_i^r \mathbf{W}^r\} &= \text{Tr}\{(\mathbf{G}_i^r \mathbf{X}^r - \mathbf{B}_i^r \mathbf{Z}^r) + \sqrt{-1}(\mathbf{B}_i^r \mathbf{X}^r + \mathbf{G}_i^r \mathbf{Z}^r)\} \\ &= \text{Tr}\{(\mathbf{G}_i^r \mathbf{X}^r - \mathbf{B}_i^r \mathbf{Z}^r)\}, \end{aligned} \quad (9)$$

where  $\text{Tr}\{\sqrt{-1}(\mathbf{B}_i^r \mathbf{X}^r + \mathbf{G}_i^r \mathbf{Z}^r)\} = 0$  because  $P_{G_i}$  is a real number. In addition,  $\mathcal{F}_r^R$  in Eqs. (4)-(6) can be equivalently expressed as:

$$\underline{P}_{G_i} \leq P_{G_i} = \text{Tr}\{(\mathbf{G}_i^r \mathbf{X}^r - \mathbf{B}_i^r \mathbf{Z}^r)\} + P_{D_i} \leq \bar{P}_{G_i}, \quad (10a)$$

$$\underline{Q}_{G_i} \leq Q_{G_i} = \text{Tr}\{(\mathbf{G}_i^r \mathbf{X}^r - \bar{\mathbf{B}}_i^r \mathbf{Z}^r)\} + Q_{D_i} \leq \bar{Q}_{G_i}, \quad (10b)$$

$$(\underline{V}_i)^2 \leq \text{Tr}\{\mathbf{M}_i^r \mathbf{X}^r\} \leq (\bar{V}_i)^2. \quad (10c)$$

We define the matrix  $\mathbf{E}_{r \rightarrow l} \in \mathbb{R}^{\bar{N}_{rl} \times \bar{N}_r}$  as

$$\mathbf{E}_{r \rightarrow l} = \left[ \bigoplus_{i \in \mathcal{P}_{rl}} e_i^{rT}; \right], \quad (11)$$

where  $e_i^r \in \mathbb{R}^{\bar{N}_r}$  and  $\bigoplus$  denotes the operator of concatenating vectors.

*Lemma 1:* We have the following relationship:

$$\mathbf{W} \succeq 0 \iff \begin{bmatrix} \mathbf{X} & -\mathbf{Z} \\ \mathbf{Z} & \mathbf{X} \end{bmatrix} \succeq 0 \quad (12)$$

*Proof:* We show the detailed proof in the Appendix.

Based on Lemma 1, we write (P2) in terms of  $\mathbf{X}^r, \mathbf{Z}^r$  as follows:

$$(P3) : \min \sum_{r=1}^R C^r(P_G^r) \quad (13a)$$

$$\text{s.t.} \quad \{\mathbf{X}^r, \mathbf{Z}^r, P_G^r, Q_G^r\} \in \mathcal{F}_r^R, \forall r = 1, \dots, R, \quad (13b)$$

$$\mathbf{E}_{r \rightarrow l} \mathbf{X}^r \mathbf{E}_{r \rightarrow l}^T = \mathbf{X}_l^r, l \in \mathcal{N}^{\delta(r)}, r = 1, \dots, R, \quad (13c)$$

$$\mathbf{E}_{r \rightarrow l} \mathbf{Z}^r \mathbf{E}_{r \rightarrow l}^T = \mathbf{Z}_l^r, l \in \mathcal{N}^{\delta(r)}, r = 1, \dots, R, \quad (13d)$$

$$\begin{bmatrix} \mathbf{X}^r & -\mathbf{Z}^r \\ \mathbf{Z}^r & \mathbf{X}^r \end{bmatrix} \succeq 0, \forall r = 1, \dots, R, \quad (13e)$$

where  $\mathbf{X}_l^r = \mathbf{E}_{r \rightarrow l} \mathbf{X}^r \mathbf{E}_{r \rightarrow l}^T$ ,  $\mathbf{Z}_l^r = \mathbf{E}_{r \rightarrow l} \mathbf{Z}^r \mathbf{E}_{r \rightarrow l}^T$ , and  $\mathbf{E}_{r \rightarrow l} \mathbf{E}_{r \rightarrow l}^T = \mathbf{I}_{r \rightarrow l} \in \mathbb{R}^{\bar{N}_{rl} \times \bar{N}_{rl}}$ .

### C. Distributed Optimal Power Flow

Solving (P3) directly is likely to incur infeasible solutions. In particular, when we solve (P3) for region  $r$  and pass the messages to region  $l$ , the additional equality constraints, i.e., (13c) - (13d), may cause the boundary variables described by the messages infeasible for (13d) in region  $l$ . This is because the number of equality constraints in each subproblem may be larger than the number of its variables or these messages

do not lie in the intersection of the feasible regions of all the subproblems.

Therefore, in this subsection, we propose a distributed algorithm to solve (P3). Instead of solving (P3) directly, we relax (P3) by utilizing the augmented partial Lagrangian. In particular, (13c) - (13d) in region  $r$  are replaced by the augmented Lagrangian terms in its objective. Once the distributed algorithm converges, optimal solutions to the augmented partial Lagrangians of different regions will satisfy (13c) - (13d) simultaneously. We consider the partial augmented Lagrangian:

$$(P4) : \min_{\{\mathbf{X}^r\}, \{\mathbf{Z}^r\}, \{\Gamma_l^r\}, \{\Lambda_l^r\}, r=1, \dots, R} \mathcal{L}_{admm}^r = \sum_{r=1}^R \mathcal{L}_{admm}^r = \sum_{r=1}^R \left\{ C^r(P_G^r) + \sum_{l \in \mathcal{N}^{\delta(r)}} [\text{Tr}((\Gamma_l^r)^T (\mathbf{E}_{r \rightarrow l} \mathbf{X}^r \mathbf{E}_{r \rightarrow l}^T - \mathbf{X}_r^l)) + \text{Tr}((\Lambda_l^r)^T (\mathbf{E}_{r \rightarrow l} \mathbf{Z}^r \mathbf{E}_{r \rightarrow l}^T - \mathbf{Z}_r^l)) + \frac{1}{2} \|\sqrt{\rho_{rl}} \circ (\mathbf{E}_{r \rightarrow l} \mathbf{X}^r \mathbf{E}_{r \rightarrow l}^T - \mathbf{X}_r^l)\|_F^2 + \frac{1}{2} \|\sqrt{\kappa_{rl}} \circ (\mathbf{E}_{r \rightarrow l} \mathbf{Z}^r \mathbf{E}_{r \rightarrow l}^T - \mathbf{Z}_r^l)\|_F^2] \right\} \quad (14a)$$

$$\text{s.t. } \{\mathbf{X}^r, \mathbf{Z}^r, P_G^r, Q_G^r\} \in \mathcal{F}_r^{\mathbb{R}}, \forall r = 1, \dots, R, \quad (14b)$$

$$\begin{bmatrix} \mathbf{X}^r & -\mathbf{Z}^r \\ \mathbf{Z}^r & \mathbf{X}^r \end{bmatrix} \succeq 0, \forall r = 1, \dots, R, \quad (14c)$$

where  $\rho_{rl}, \kappa_{rl} \in \mathbb{R}^{\bar{N}_{ri} \times \bar{N}_{ri}}$  are matrices with positive entries, and  $\circ$  denotes Hadamard product. In addition,  $\{\Gamma_l^r\}$  and  $\{\Lambda_l^r\}$  denote the multipliers associated with (13c) and (13d). Note that, the gradients of  $\frac{1}{2} \|\sqrt{\rho_{rl}} \circ (\mathbf{E}_{r \rightarrow l} \mathbf{X}^r \mathbf{E}_{r \rightarrow l}^T - \mathbf{X}_r^l)\|_F^2$  and  $\frac{1}{2} \|\sqrt{\kappa_{rl}} \circ (\mathbf{E}_{r \rightarrow l} \mathbf{Z}^r \mathbf{E}_{r \rightarrow l}^T - \mathbf{Z}_r^l)\|_F^2$  require successive communication between agents in each iteration, which can disclose the states of neighboring agents. Taking  $\mathbf{X}^r$  for example, the gradient of  $\frac{1}{2} \|\sqrt{\rho_{rl}} \circ (\mathbf{E}_{r \rightarrow l} \mathbf{X}^r \mathbf{E}_{r \rightarrow l}^T - \mathbf{X}_r^l)\|_F^2$  is  $\rho_{rl} \circ (\mathbf{E}_{r \rightarrow l} \mathbf{X}^r \mathbf{E}_{r \rightarrow l}^T - \mathbf{X}_r^l)$ . Observing from the gradient, it is obvious that updating  $\mathbf{X}^r$  by agent  $r$  in each iteration requires the values of  $\mathbf{X}_r^l$  from neighboring agent  $l$ . As a result, the values of  $\mathbf{X}_r^l$  are exposed to both honest-but-curious agents and external eavesdroppers.

To solve this problem, we approximate the augmented terms by the  $\ell_1$ -norm regularization. The mechanism is motivated by the fact that the subgradients of the  $\ell_1$ -norm regularization terms are the sign messages. Therefore, we can introduce a third party to provide the sign messages for agent  $r$  to update  $\mathbf{X}^r$ . In this way, the two kinds of adversaries cannot infer any information through eavesdropping all the communication channels and exchanged messages between agents, as will be clearer in Algorithm 2. Based on the above discussion, the implementation of the relaxed ADMM method with the  $\ell_1$ -norm regularization is elaborated as follows:

S1) Update primal variables:

$$\{\mathbf{X}^r(t+1)\}, \{\mathbf{Z}^r(t+1)\} = \min_{\{\mathbf{X}^r\}, \{\mathbf{Z}^r\}} \mathcal{L}_{admm}^{r,1} = C^r(P_G^r) + \sum_{l \in \mathcal{N}^{\delta(r)}} [\text{Tr}((\Gamma_l^r(t))^T (\mathbf{E}_{r \rightarrow l} \mathbf{X}^r \mathbf{E}_{r \rightarrow l}^T - \mathbf{X}_r^l)) + \text{Tr}((\Lambda_l^r(t))^T (\mathbf{E}_{r \rightarrow l} \mathbf{Z}^r \mathbf{E}_{r \rightarrow l}^T - \mathbf{Z}_r^l)) + \alpha \|\text{vec}(\mathbf{E}_{r \rightarrow l} \mathbf{X}^r \mathbf{E}_{r \rightarrow l}^T - \mathbf{X}_r^l)\|_1 + \alpha \|\text{vec}(\mathbf{E}_{r \rightarrow l} \mathbf{Z}^r \mathbf{E}_{r \rightarrow l}^T - \mathbf{Z}_r^l)\|_1] \quad (15a)$$

$$\text{s.t. } \{\mathbf{X}^r, \mathbf{Z}^r, P_G^r, Q_G^r\} \in \mathcal{F}_r^{\mathbb{R}}, \quad (15b)$$

$$\begin{bmatrix} \mathbf{X}^r & -\mathbf{Z}^r \\ \mathbf{Z}^r & \mathbf{X}^r \end{bmatrix} \succeq 0, \quad (15c)$$

where (15) is an approximation to (14) by replacing the Frobenius norm by the  $\ell_1$ -norm regularization and  $\text{vec}(\cdot)$  denotes the operator that reshapes a matrix to a vector. In addition,  $\alpha$  is a fixed positive weighting factor, which is tuned to approach the global optimal solution to (P3).

S2) Update dual variables:

$$\{\Gamma_l^r(t+1)\} = \{\Gamma_l^r(t)\} + \rho_{rl} \circ ((\mathbf{X}_l^r(t+1)) - \mathbf{X}_r^l) \quad (16)$$

$$\{\Lambda_l^r(t+1)\} = \{\Lambda_l^r(t)\} + \kappa_{rl} \circ ((\mathbf{Z}_l^r(t+1)) - \mathbf{Z}_r^l) \quad (17)$$

In Step (S1), the per-area matrices  $\mathbf{X}^r(t+1), \mathbf{Z}^r(t+1)$  are obtained by minimizing (15) with  $\{\Gamma_l^r\}$  and  $\{\Lambda_l^r\}$  fixed to their previous iteration values. Likewise, the dual variables  $\{\Gamma_l^r\}$  and  $\{\Lambda_l^r\}$  are updated by (16) and (17) by fixing  $\mathbf{X}^r(t+1), \mathbf{Z}^r(t+1)$  to their up-to-date values. In particular, the initial values of  $\{\Gamma_l^r(0)\}$  and  $\{\Lambda_l^r(0)\}$  are zero matrices. Therefore,  $\{\Gamma_l^r(t)\}$  and  $\{\Lambda_l^r(t)\}, \forall t, r, l$  are symmetric and skew-symmetric matrices, respectively. Notice that  $t$  indexes the outer iterations to conduct (S1) and (S2) steps alternately.

We are ready to write the subgradient of  $\mathcal{L}^r$  with respect to  $\mathbf{X}^r$  and  $\mathbf{Z}^r$ .

$$\begin{aligned} \partial \mathcal{L}_{admm}^{r,1} / \partial \mathbf{X}^r &= \sum_{i=1}^{|\mathcal{R}_r|} [2a_i (\mathbf{G}_i^r)^T (\text{Tr}\{(\mathbf{G}_i^r \mathbf{X}^r - \mathbf{B}_i^r \mathbf{Z}^r)\} + P_{D_i}) \\ &+ b_i (\mathbf{G}_i^r)^T] + \sum_{l \in \mathcal{N}^{\delta(r)}} [\mathbf{E}_{r \rightarrow l}^T (\Gamma_l^r + \alpha(\text{sign}(\mathbf{X}_l^r - \mathbf{X}_r^l)) \mathbf{E}_{r \rightarrow l})], \end{aligned} \quad (18)$$

$$\begin{aligned} \partial \mathcal{L}_{admm}^{r,1} / \partial \mathbf{Z}^r &= \sum_{i=1}^{|\mathcal{R}_r|} [2a_i (-\mathbf{B}_i^r)^T (\text{Tr}\{(\mathbf{G}_i^r \mathbf{X}^r - \mathbf{B}_i^r \mathbf{Z}^r)\} + P_{D_i}) \\ &+ b_i (-\mathbf{B}_i^r)^T] + \sum_{l \in \mathcal{N}^{\delta(r)}} [\mathbf{E}_{r \rightarrow l}^T (\Lambda_l^r + \alpha(\text{sign}(\mathbf{Z}_l^r - \mathbf{Z}_r^l)) \mathbf{E}_{r \rightarrow l})]. \end{aligned} \quad (19)$$

Here,  $a_i = b_i = c_i = 0$  if  $i \in \mathcal{R}_r / \mathcal{R}_r^g$ .  $\text{sign}(\mathbf{X})$  denotes the sign signals of each element in  $\mathbf{X}$ . Define

$$\mathcal{O}_{rl} = \{(i, i), (i, j), (j, i), (j, j)\}, \quad (20)$$

where line  $ij$  connects region  $r$  and region  $l$ . For example,  $\mathbf{X}_{l,o}^r, \forall o \in \mathcal{O}_{rl}$  is a element of  $\mathbf{X}_l^r$ .

In particular, the subgradients of  $|\mathbf{X}_{l,o}^r - \mathbf{X}_{r,o}^l|$  and  $|\mathbf{Z}_{l,o}^r - \mathbf{Z}_{r,o}^l|$  are

$$\partial |\mathbf{X}_{l,o}^r - \mathbf{X}_{r,o}^l| / \partial \mathbf{X}_{l,o}^r = \begin{cases} 1, & \mathbf{X}_{l,o}^r > \mathbf{X}_{r,o}^l \\ -1, & \mathbf{X}_{l,o}^r < \mathbf{X}_{r,o}^l \\ [-1, 1], & \mathbf{X}_{l,o}^r = \mathbf{X}_{r,o}^l \end{cases}, \quad (21)$$

$$\partial|\mathbf{Z}_{i,o}^r - \mathbf{Z}_{r,o}^l|/\partial\mathbf{Z}_{i,o}^r = \begin{cases} 1, & \mathbf{Z}_{i,o}^r > \mathbf{Z}_{r,o}^l \\ -1, & \mathbf{Z}_{i,o}^r < \mathbf{Z}_{r,o}^l \\ [-1, 1], & \mathbf{Z}_{i,o}^r = \mathbf{Z}_{r,o}^l \end{cases}, \quad (22)$$

With the above subgradient, we utilize the standard subgradient method to iterate toward the optimal solution [28]. We write the iterative subgradient method to solve (15) as

$$\begin{bmatrix} \mathbf{X}^r(k+1) \\ \mathbf{Z}^r(k+1) \end{bmatrix} = \Phi \left( \begin{bmatrix} \mathbf{X}^r(k) \\ \mathbf{Z}^r(k) \end{bmatrix}, \begin{bmatrix} (\partial\mathcal{L}_{admm}^{r,1}/\partial\mathbf{X}^r)(k) \\ (\partial\mathcal{L}_{admm}^{r,1}/\partial\mathbf{Z}^r)(k) \end{bmatrix} \right), \quad (23)$$

where  $\Phi(\cdot)$  denotes the iteration function that will be elaborated in (26) and (27). Note that  $k$  indexes the inner iterations to solve (15).

*Proposition 1:* Problem (15) can be formulated as the standard form:

$$\text{Primal: } \arg \min \text{Tr}(A_0(\boldsymbol{\theta})^T X), \quad (24a)$$

$$\text{Tr}(A_m^T X) = b_m, \forall m = \{1, \dots, M\} \quad (24b)$$

$$X \succeq 0. \quad (24c)$$

where  $A_0(\boldsymbol{\theta})$  is relevant to the message communications of the subgradients and  $M$  is the number of constraints. In addition,  $A_m \in \mathbb{R}^{D \times D}$ ,  $X \in \mathbb{R}^{D \times D}$  and  $b_m \in \mathbb{R}$  will be constructed in the Appendix, where  $D$  is the dimension of  $X$ . For conciseness, we omit the notation  $\boldsymbol{\theta}$  in the following. The dual problem of (24) is

$$\text{Dual: } \max b^T y, \quad (25a)$$

$$A_0 - \sum_{m=1}^M y_m A_m \succeq 0, \quad (25b)$$

where  $b = [b_1, \dots, b_M]^T$  and  $y \in \mathbb{R}^m$  is the vector of dual variables.

*Proof:* We show the detailed proof in the Appendix.

Referring to [29], the update scheme  $\Phi(\cdot)$  for (25) is

$$B\Delta y = r \quad (26a)$$

$$\Delta X = P + \sum_{m=1}^M A_m \Delta y_m \quad (26b)$$

$$\Delta \hat{Z} = (X^k)^{-1}(R - Z^k \Delta X) \quad (26c)$$

$$\Delta Z = (\hat{Z} + \hat{Z}^T)/2 \quad (26d)$$

where

$$B_{mn} = \text{Tr}([(X^k)^{-1} A_m Z^k]^T A_n), \forall m, n = 1, \dots, M, \quad (27a)$$

$$r_m = -d_m + \text{Tr}(A_m^T [(X^k)^{-1}(R - PZ^k)]), \forall m = 1, \dots, M, \quad (27b)$$

$$P = \sum_{m=1}^M A_m y_m^k - A_0 - X^k, \quad (27c)$$

$$d_m = b_m - \text{Tr}(A_m^T Z^k), \forall m = 1, \dots, M, \quad (27d)$$

$$R = \beta \mu^k I - X^k Z^k, \quad (27e)$$

$$\mu^k = \text{Tr}((X^k)^T Z^k)/D. \quad (27f)$$

### Privacy-Preserving Distributed OPF Algorithm

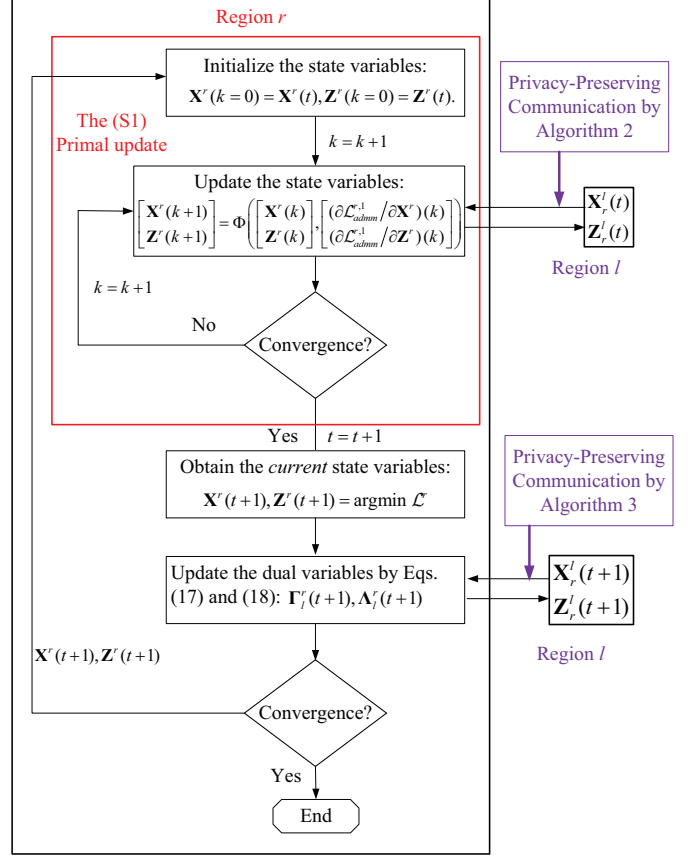

Fig. 2: The flowchart of the proposed algorithm.

The above algorithm cannot protect the privacy of multiple agents when the messages are exchanged and disclosed explicitly among neighboring agents. To avoid privacy leakage, we propose a privacy preserving distributed optimization method, which combines homomorphic cryptography and distributed optimization in the following subsection.

### D. Privacy-Preserving Distributed Algorithm

In this subsection, we combine Paillier cryptosystem with DOPF to enable privacy preservation in the (S1) and (S2) steps. We illustrate the DOPF based on PHE in Fig. 2.

First of all, the proposed DOPF based on PHE has two loops, namely the inner (S1) primal update iterations and outer iterations. In the inner (S1) primal update, we first initialize the state variables  $\mathbf{X}^r(k=0), \mathbf{Z}^r(k=0)$ . Then, we update the iterative state variables  $\mathbf{X}^r(k+1), \mathbf{Z}^r(k+1)$  according to Eq. (23), where the state variables during the inner (S1) update (i.e., the  $k$ th iteration) are infeasible to  $\mathcal{F}_r^{\mathbb{R}}$  unless the inner (S1) update converges. In contrast, the state variables during the outer (S2) dual update (i.e., the  $t$ th iteration) are always feasible to  $\mathcal{F}_r^{\mathbb{R}}$ .

In particular, Eq. (23) requires agent  $r$  to successively compare its iterative states (i.e.,  $\mathbf{X}_i^r(k), \mathbf{Z}_i^r(k)$ ) from agent  $l$ 's previous intermediate states (i.e.,  $\mathbf{X}_i^l(t), \mathbf{Z}_i^l(t)$ ) in each inner iteration  $k$ . In this process, the communication between agent

$r$  and agent  $l$  can expose its sensitive information to each other or eavesdroppers. Therefore, we propose Algorithm 2 to enable the privacy-preserving communication in the (S1) primal update.

After the inner (S1) primal update converges, agent  $r$  obtains the next intermediate states  $\mathbf{X}^r(t+1), \mathbf{Z}^r(t+1)$ . Then, agent  $r$  updates the dual variables  $\{\Gamma_l^r(t+1)\}$  and  $\{\Lambda_l^r(t+1)\}$  with the help of the communication from agent  $l$  about its current intermediate states, i.e.,  $\mathbf{X}_r^l(t+1), \mathbf{Z}_r^l(t+1)$ . However, this process is likely to leak the agents' intermediate states. To address this problem, we propose Algorithm 3 to facilitate the privacy preserving communication in the dual update.

---

**Algorithm 2:** Privacy-Preserving Message Communication for the (S1) (Primal) update

---

- 1 **Agent**  $r$  encrypts  $\mathbf{X}_{l,o}^r(k)$  and  $\mathbf{Z}_{l,o}^r(k)$  with its public key  $k_{pi}$ :

$$\begin{aligned} \mathbf{X}_{l,o}^r(k) &\mapsto \mathcal{E}(\mathbf{X}_{l,o}^r(k)), \forall o \in \mathcal{O}_{rl}, \\ \mathbf{Z}_{l,o}^r(k) &\mapsto \mathcal{E}(\mathbf{Z}_{l,o}^r(k)), \forall o \in \mathcal{O}_{rl}, \end{aligned} \quad (28)$$

where the superscript  $r$  denotes encryption using the public key of **Agent**  $r$ ;

- 2 **Agent**  $r$  sends  $\mathcal{E}(\mathbf{X}_{l,o}^r(k))$  and  $\mathcal{E}(\mathbf{Z}_{l,o}^r(k))$ , and its public key  $k_{pi}$  to neighboring **Agent**  $l$ ;
- 3 **Agent**  $l$  encrypts  $\mathbf{X}_{r,o}^l(t)$  and  $\mathbf{Z}_{r,o}^l(t)$  with its public key  $k_{pi}$ :

$$\begin{aligned} \mathbf{X}_{r,o}^l(t) &\mapsto \mathcal{E}(-\mathbf{X}_{r,o}^l(t)), \\ \mathbf{Z}_{r,o}^l(t) &\mapsto \mathcal{E}(-\mathbf{Z}_{r,o}^l(t)), \end{aligned} \quad (29)$$

where  $\forall o \in \mathcal{O}_{rl}$ ;

- 4 **Agent**  $l$  computes the difference directly in ciphertext:

$$\begin{aligned} \mathcal{E}(\mathbf{X}_{l,o}^r(k) - \mathbf{X}_{r,o}^l(t)) &= \mathcal{E}(\mathbf{X}_{l,o}^r(k)) \cdot \mathcal{E}(-\mathbf{X}_{r,o}^l(t)), \\ \mathcal{E}(\mathbf{Z}_{l,o}^r(k) - \mathbf{Z}_{r,o}^l(t)) &= \mathcal{E}(\mathbf{Z}_{l,o}^r(k)) \cdot \mathcal{E}(-\mathbf{Z}_{r,o}^l(t)), \end{aligned} \quad (30)$$

since Paillier system is additively homomorphic;

- 5 **Agent**  $l$  computes the  $c_{l \rightarrow r}(k)$  and  $d_{l \rightarrow r}(k)$ -weighted difference in ciphertext:

$$\begin{aligned} \mathcal{E}(c_{l \rightarrow r}(k)(\mathbf{X}_{l,o}^r(k) - \mathbf{X}_{r,o}^l(t))) &= \\ (\mathcal{E}(\mathbf{X}_{l,o}^r(k) - \mathbf{X}_{r,o}^l(t)))^{c_{l \rightarrow r}(k)}, \\ \mathcal{E}(d_{l \rightarrow r}(k)(\mathbf{Z}_{l,o}^r(k) - \mathbf{Z}_{r,o}^l(t))) &= \\ (\mathcal{E}(\mathbf{Z}_{l,o}^r(k) - \mathbf{Z}_{r,o}^l(t)))^{d_{l \rightarrow r}(k)}, \end{aligned} \quad (31)$$

and sends  $\mathcal{E}(c_{l \rightarrow r}(k)(\mathbf{X}_{l,o}^r(k) - \mathbf{X}_{r,o}^l(t)))$  and  $\mathcal{E}(d_{l \rightarrow r}(k)(\mathbf{Z}_{l,o}^r(k) - \mathbf{Z}_{r,o}^l(t)))$  back to **System Operator**;

- 6 **Agent**  $r$  sends its private key  $k_{si}^a$  to **System Operator**;
- 7 **System Operator** decrypts the message received from **Agent**  $l$  with its private key  $k_{si}^a$  to get  $c_{l \rightarrow r}(k)(\mathbf{X}_{l,o}^r(k) - \mathbf{X}_{r,o}^l(t))$  and  $d_{l \rightarrow r}(k)(\mathbf{Z}_{l,o}^r(k) - \mathbf{Z}_{r,o}^l(t))$ ;
- 8 **System Operator** obtains the sign of the two messages, i.e.,  $\text{sign}(c_{l \rightarrow r}(k)(\mathbf{X}_{l,o}^r(k) - \mathbf{X}_{r,o}^l(t)))$  and  $\text{sign}(d_{l \rightarrow r}(k)(\mathbf{Z}_{l,o}^r(k) - \mathbf{Z}_{r,o}^l(t)))$ , and sends the sign messages to **Agent**  $r$ ;
- 9 When the two messages  $c_{l \rightarrow r}(k)(\mathbf{X}_{l,o}^r(k) - \mathbf{X}_{r,o}^l(t))$  and  $d_{l \rightarrow r}(k)(\mathbf{Z}_{l,o}^r(k) - \mathbf{Z}_{r,o}^l(t)) \forall r, l$  are zeros, **System Operator** informs all agents that the algorithm converges. As a result, primal intermediate states at  $t+1$ th iteration are obtained by (15);
- 

---

**Algorithm 3:** Privacy-Preserving Message Communication for the (S2) (Dual) update

---

- 1 **Agent**  $r$  encrypts  $-\mathbf{X}_{l,o}^r(t)$  and  $-\mathbf{Z}_{l,o}^r(t)$  with its public key  $k_{pi}$ , similar to (28);
- 2 **Agent**  $r$  sends  $\mathcal{E}(-\mathbf{X}_{l,o}^r(t))$  and  $\mathcal{E}(-\mathbf{Z}_{l,o}^r(t))$ , and its public key  $k_{pi}$  to neighboring **Agent**  $l$ ;
- 3 **Agent**  $l$  encrypts  $\mathbf{X}_{r,o}^l(t)$  and  $\mathbf{Z}_{r,o}^l(t)$  with its public key  $k_{pi}$ , similar to (29);
- 4 **Agent**  $l$  computes the difference, i.e.,  $\mathcal{E}(\mathbf{X}_{r,o}^l(t) - \mathbf{X}_{l,o}^r(t))$  and  $\mathcal{E}(\mathbf{Z}_{r,o}^l(t) - \mathbf{Z}_{l,o}^r(t))$ , directly in ciphertext, similar to (30);
- 5 **Agent**  $l$  computes the  $a_{l \rightarrow r}(t)$  and  $b_{l \rightarrow r}(t)$ -weighted difference, i.e.,  $\mathcal{E}(a_{l \rightarrow r}(t)(\mathbf{X}_{r,o}^l(t) - \mathbf{X}_{l,o}^r(t)))$  and  $\mathcal{E}(b_{l \rightarrow r}(t)(\mathbf{Z}_{r,o}^l(t) - \mathbf{Z}_{l,o}^r(t)))$  in ciphertext, similar to (31);
- 6 **Agent**  $l$  sends  $\mathcal{E}(a_{l \rightarrow r}(t)(\mathbf{X}_{r,o}^l(t) - \mathbf{X}_{l,o}^r(t)))$  and  $\mathcal{E}(b_{l \rightarrow r}(t)(\mathbf{Z}_{r,o}^l(t) - \mathbf{Z}_{l,o}^r(t)))$  back to **Agent**  $r$ ;
- 7 **Agent**  $r$  decrypts the message received from **Agent**  $l$  with its private key  $k_{si}$  and multiplies the result with  $a_{r \rightarrow l}(t)$  and  $b_{r \rightarrow l}(t)$  to get  $\rho_{rl}(t)(\mathbf{X}_{l,o}^r(t) - \mathbf{X}_{r,o}^l(t))$  and  $\kappa_{rl}(t)(\mathbf{Z}_{l,o}^r(t) - \mathbf{Z}_{r,o}^l(t))$ :

$$\begin{aligned} \rho_{rl}(t) &= a_{l \rightarrow r}(t) \cdot a_{r \rightarrow l}(t), \\ \kappa_{rl}(t) &= b_{l \rightarrow r}(t) \cdot b_{r \rightarrow l}(t). \end{aligned} \quad (32)$$

Computing (16) and (17) to update dual variables in iteration  $t$ ;

---

In the following, we introduce the privacy-preserving communications between participating agents. In particular, for the (S1) inner update, Eqs. (18) and (19) require the exchanged messages, i.e.,  $\text{sign}(\mathbf{X}_l^r - \mathbf{X}_r^l)$  and  $\text{sign}(\mathbf{Z}_l^r - \mathbf{Z}_r^l)$ . In Step (S2), we have  $(\rho_{rl} \circ (\mathbf{X}_l^r - \mathbf{X}_r^l))$  and  $(\kappa_{rl} \circ (\mathbf{Z}_l^r - \mathbf{Z}_r^l))$ . They require message communications among regions. Noticeably, Paillier encryption cannot be performed on matrices directly. Therefore, each element of the matrix, e.g.,  $\mathbf{X}_l^r$  and  $\mathbf{Z}_l^r$ , are encrypted separately. We summarize the Algorithms 2 and 3 as follows.

- For the (S1) update, agent  $l$  generates two random positive scalars, i.e.,  $c_{l \rightarrow r}(k)$  and  $d_{l \rightarrow r}(k)$ , to multiply the differences of the two messages in the  $k$ th iteration. Then, the encrypt weighted differences of the two messages (in ciphertext) are sent to the system operator. The system operator sends the sign signals to agent  $r$ . The privacy-preserving message communication for the primal update is elaborated in Algorithm 2.
- For the (S2) update, we construct  $\rho_{rl}(t)$  and  $\kappa_{rl}(t)$ ,  $r \neq l$  as the product of two random positive numbers, i.e.,  $\rho_{rl}(t) = a_{r \rightarrow l}(t) \cdot a_{l \rightarrow r}(t)$  and  $\kappa_{rl}(t) = b_{r \rightarrow l}(t) \cdot b_{l \rightarrow r}(t)$ . In particular,  $a_{r \rightarrow l}(t)$  and  $b_{r \rightarrow l}(t)$  are only known to agent  $r$ . This way, we further propose Algorithm 3 to enable the privacy-preserving message communication in the dual update.

*Remark 1:* In Step 5 of Algorithm 2,  $c_{l \rightarrow r}(k)$  and  $d_{l \rightarrow r}(k)$  are large random positive integers. The two numbers are only known to agent  $l$  and varying in each iteration.

*Remark 2:* In Steps 1-2 of Algorithm 3, agent  $r$ 's states  $\mathbf{X}_{l,o}^r$  and  $\mathbf{Z}_{l,o}^r$  are encrypted and will not be revealed to its



neighbors.

*Remark 3:* In Steps 4-5 of Algorithm 3, agent  $l$ 's state will not be revealed to agent  $r$  because the decrypted messages obtained by agent  $r$  are  $a_{l \rightarrow r}(t)(\mathbf{X}_{r,o}^l(t) - \mathbf{X}_{l,o}^r(t))$  and  $b_{l \rightarrow r}(t)(\mathbf{X}_{r,o}^l(t) - \mathbf{X}_{l,o}^r(t))$ , where  $a_{l \rightarrow r}(t)$  and  $b_{l \rightarrow r}(t)$  are only known to agent  $l$  and varying in each iteration.

*Remark 4:* Although Pailler cryptosystem only works for integers, we can take additional steps to convert real values in optimization to integers. This may lead to quantization errors. A common workaround is to scale the real value before quantization.

*Remark 5:* The key to achieve the privacy-preserving message communication is to construct  $\rho_{rl}, r \neq l$  (or  $\kappa_{rl}$ ) as the product of two random numbers  $a_{r \rightarrow l}$  and  $a_{l \rightarrow r}$  (or  $b_{r \rightarrow l}$  and  $b_{l \rightarrow r}$ ) generated by and only known by corresponding agents. Therefore, the convergence of algorithm is affected by the random, time-varying  $\rho_{rl}$  and  $\kappa_{rl}$ .

#### IV. PRIVACY ANALYSIS AND STOPPING CRITERION

In the section, we analyze the privacy of agents' immediate states, and convergence of Algorithms 2 and 3. In addition, we also prove that the private information, including agents' gradients and the objective functions, cannot be inferred by honest-but-curious adversaries, external eavesdroppers, and the system operator over time.

##### A. Privacy Analysis

*Theorem 1:* Assume that all agents follow Algorithm 2. Then agent  $l$ 's exact state values  $\mathbf{X}_r^l(t)$  and  $\mathbf{Z}_r^l(t)$  over the boundaries cannot be inferred by an honest-but-curious agent  $r$  and the system operator unless  $\mathbf{X}_i^r(k) = \mathbf{X}_r^l(t)$  and  $\mathbf{Z}_i^r(k) = \mathbf{Z}_r^l(t)$ .

*Proof:* In Algorithm 2, we have two potential adversaries, i.e., the honest-but-curious agent  $r$  and the system operator.

- The honest-but-curious agent  $r$  only obtains the sign messages from the agent  $l$ , i.e.,  $\text{sign}(c_{l \rightarrow r}(k)(\mathbf{X}_{l,o}^r(k) - \mathbf{X}_{r,o}^l(t)))$  and  $\text{sign}(d_{l \rightarrow r}(k)(\mathbf{Z}_{l,o}^r(k) - \mathbf{Z}_{r,o}^l(t)))$ . Taking  $\mathbf{X}$  for example, the honest-but-curious agent  $r$  collects information from  $K$  iterations:

$$\begin{aligned} \mathbf{y}_s^0 &= \text{sign}(c_{l \rightarrow r}(0)(\mathbf{X}_{l,o}^r(0) - \mathbf{X}_{r,o}^l(t))), \\ \mathbf{y}_s^1 &= \text{sign}(c_{l \rightarrow r}(1)(\mathbf{X}_{l,o}^r(1) - \mathbf{X}_{r,o}^l(t))), \\ &\dots \\ \mathbf{y}_s^K &= \text{sign}(c_{l \rightarrow r}(K)(\mathbf{X}_{l,o}^r(K) - \mathbf{X}_{r,o}^l(t))). \end{aligned}$$

To the honest-but-curious agent  $r$ , the sign signals  $\mathbf{y}_s^k$  and  $\mathbf{X}_{l,o}^r(k)$  are known, while  $\mathbf{X}_{r,o}^l(t)$  and  $c_{l \rightarrow r}(k)$  are unknown. Therefore,  $\mathbf{X}_{r,o}^l(t)$  cannot be inferred by the honest-but-curious agent  $r$ .

- The third-party system operator only obtains the weighted differences of two messages from the agent  $l$ , i.e.,  $(c_{l \rightarrow r}(k)(\mathbf{X}_{l,o}^r(k) - \mathbf{X}_{r,o}^l(t)))$  and  $(d_{l \rightarrow r}(k)(\mathbf{Z}_{l,o}^r(k) - \mathbf{Z}_{r,o}^l(t)))$ . Taking  $\mathbf{X}$  for example, the third-party system operator collects information from  $K$  iterations:

$$\mathbf{y}_t^0 = (c_{l \rightarrow r}(0)(\mathbf{X}_{l,o}^r(0) - \mathbf{X}_{r,o}^l(t))),$$

$$\mathbf{y}_t^1 = (c_{l \rightarrow r}(1)(\mathbf{X}_{l,o}^r(1) - \mathbf{X}_{r,o}^l(t))),$$

...

$$\mathbf{y}_t^K = (c_{l \rightarrow r}(K)(\mathbf{X}_{l,o}^r(K) - \mathbf{X}_{r,o}^l(t))).$$

To the third-party system operator, only the signals  $\mathbf{y}_t^k$  are known, while  $\mathbf{X}_{l,o}^r(k)$ ,  $\mathbf{X}_{r,o}^l(t)$  and  $c_{l \rightarrow r}(k)$  are unknown. Therefore,  $\mathbf{X}_{l,o}^r(k), \forall k = 1, \dots, K$  and  $\mathbf{X}_{r,o}^l(t)$  cannot be inferred by the the third-party system operator.

This completes the proof.  $\blacksquare$

*Theorem 2:* Assume that all agents follow Algorithm 3. Then agent  $l$ 's exact state values  $\mathbf{X}_r^l(t)$  and  $\mathbf{Z}_r^l(t)$  over the boundaries cannot be inferred by an honest-but-curious agent  $r$  unless  $\mathbf{X}_i^r(t) = \mathbf{X}_r^l(t)$  and  $\mathbf{Z}_i^r(t) = \mathbf{Z}_r^l(t)$ .

*Proof:* Suppose that an honest-but-curious agent  $r$  collects information from  $T$  outer iterations to infer the information of a neighboring agent  $l$ . From the perspective of adversary agent  $r$ , the measurements received by agent  $r$  in the outer  $t$ th iteration are  $\mathbf{y}_x^t = a_{r \rightarrow l}(t) \cdot a_{l \rightarrow r}(t)(\mathbf{X}_{l,o}^r(t) - \mathbf{X}_{r,o}^l(t))$  and  $\mathbf{y}_z^t = b_{r \rightarrow l}(t) \cdot b_{l \rightarrow r}(t)(\mathbf{Z}_{l,o}^r(t) - \mathbf{Z}_{r,o}^l(t))$  ( $o \in \mathcal{O}_{rl}, t = 0, 1, \dots, T$ ). In this way, the honest-but-curious agent  $r$  can establish  $(T + 1) \times |\mathcal{O}_{rl}| \times 2$  equations. In the following, we consider one element of  $\mathbf{X}_i^r$ .

$$\begin{aligned} \mathbf{y}_x^0 &= a_{r \rightarrow l}(0) \cdot a_{l \rightarrow r}(0)(\mathbf{X}_{l,o}^r(0) - \mathbf{X}_{r,o}^l(0)), \\ \mathbf{y}_x^1 &= a_{r \rightarrow l}(1) \cdot a_{l \rightarrow r}(1)(\mathbf{X}_{l,o}^r(1) - \mathbf{X}_{r,o}^l(1)), \\ &\dots \\ \mathbf{y}_x^T &= a_{r \rightarrow l}(T) \cdot a_{l \rightarrow r}(T)(\mathbf{X}_{l,o}^r(T) - \mathbf{X}_{r,o}^l(T)). \end{aligned} \quad (35)$$

To the honest-but-curious agent  $r$  in the above system,  $\mathbf{y}_x^t, a_{r \rightarrow l}(t), \mathbf{X}_{l,o}^r(t)$  ( $t = 0, 1, \dots, T$ ) are known, but  $a_{l \rightarrow r}(t)$  and  $\mathbf{X}_{r,o}^l(t)$  ( $t = 0, 1, \dots, T$ ) are unknown. Therefore, the system of Eq. (35) over  $T + 1$  equations contains  $2 * (T + 1)$  unknown variables. Therefore, the honest-but-curious agent  $r$  cannot solve the system of Eq. (35) to infer the exact values of unknowns  $a_{l \rightarrow r}(t)$  and  $\mathbf{X}_{r,o}^l(t)$  ( $t = 0, 1, \dots, T$ ) of agent  $l$ , except when  $\mathbf{y}_x^t = 0$  and  $\mathbf{X}_{l,o}^r(t) = \mathbf{X}_{r,o}^l(t)$ .

This completes the proof.  $\blacksquare$

*Theorem 3:* Assume that all agents follow Algorithms 2 and 3. Then exact gradient of  $C^l$  of agent  $l$  cannot be inferred by an honest-but-curious agent  $r$ .

*Proof:* Recall that

$$\begin{aligned} \nabla_{\mathbf{X}^l} C_i^l &= [2a_i(\mathbf{G}_i^l)^T (\text{Tr}\{(\mathbf{G}_i^l \mathbf{X}^l - \mathbf{Z}_i^l \mathbf{Z}^l)\} + P_{D_i}) + b_i(\mathbf{G}_i^l)^T], \\ \nabla_{\mathbf{Z}^l} C_i^l &= [2a_i(-\mathbf{Z}_i^l)^T (\text{Tr}\{(\mathbf{G}_i^l \mathbf{X}^l - \mathbf{Z}_i^l \mathbf{Z}^l)\} + P_{D_i}) - b_i(\mathbf{Z}_i^l)^T]. \end{aligned}$$

If the generator  $G_i$  is not on the boundary of region  $r$  and region  $l$ , the messages  $\mathbf{X}_r^l$  and  $\mathbf{Z}_r^l$  do not include the generator  $G_i$ . Therefore, the above gradient of  $C^l$  of agent  $l$  cannot be inferred by an honest-but-curious agent  $r$ .

Otherwise, Theorem 2 proves that the messages  $\mathbf{X}_r^l$  and  $\mathbf{Z}_r^l$  cannot be inferred by an honest-but-curious agent  $r$ . Therefore,  $\nabla_{\mathbf{X}^l} C_i^l$  and  $\nabla_{\mathbf{Z}^l} C_i^l$  cannot be inferred.  $\blacksquare$

*Corollary 1:* Assume that all agents follow Algorithm 2. The agent  $l$ 's intermediate states, gradients of objective functions, and objective functions cannot be inferred by an external eavesdropper.

*Proof:* Since all exchanged messages are encrypted, an external eavesdropper cannot learn anything by intercepting these messages. In addition, the sign signals do not expose any state information to eavesdroppers. Therefore, it cannot infer any agent's intermediate states, gradients of objective functions, and objective functions. ■

*Corollary 2:* Assume that all agents follow Algorithm 3. Both the agent  $r$  and agent  $l$ 's intermediate states, gradients of objective functions, and objective functions cannot be inferred by an external eavesdropper and the third party.

*Proof:* Following a similar line to the reasoning of Corollary 1 and Theorem 2, we can obtain Corollary 2. ■

### B. Stopping Criterion

We define the residual as follows.

$$\Psi_r = \left\| \begin{bmatrix} \mathbf{X}_l^r \\ \mathbf{Z}_l^r \end{bmatrix} - \begin{bmatrix} \mathbf{X}_r^l \\ \mathbf{Z}_r^l \end{bmatrix} \right\|_2. \quad (36)$$

The residue gives rise to the following stopping criterion:

$$\Psi_r(t+1) \leq \epsilon, \forall r = 1, \dots, R, \quad (37)$$

where  $\Psi_r(t+1)$  is the primal residue after  $t+1$  iterations. If  $\Psi_r(t+1), \forall r$  approach zeros, the feasibility of the primal variables and the convergence of the dual variables are both satisfied.

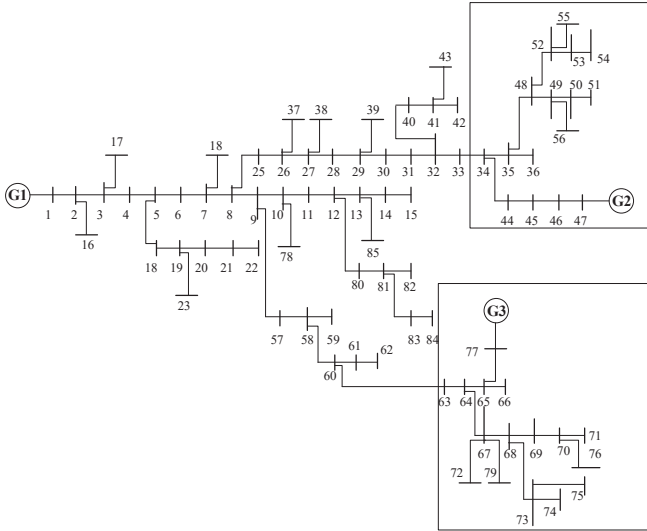

Fig. 3: The 85-bus tree distribution system with three regions.

## V. CASE STUDIES

In this section, we adopt the 85-bus tree distribution system to validate the proposed privacy-preserving distributed OPF algorithm. We partition the system into three regions, as shown in Fig. 3. In particular, two AC generators are added to buses 47 and 77, where fuel cost parameters are  $a_i = 0.2$ ,  $b_i = 2$  and  $c_i = 2$ . Other data for the 85-bus system can be found in MATPOWER's library. We set  $\epsilon = 10^{-6}$  as the termination criterion of the distributed algorithm.

We set  $N_{max} = 10^{10}$  to convert each element in  $\mathbf{X}$  and  $\mathbf{Z}$  to a 64-bit integer during intermediate computation.

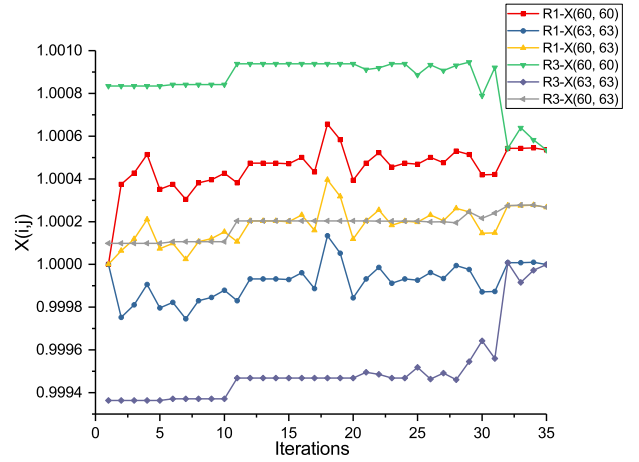

Fig. 4: The evolution of  $\mathbf{X}_{l,o}^r$ .

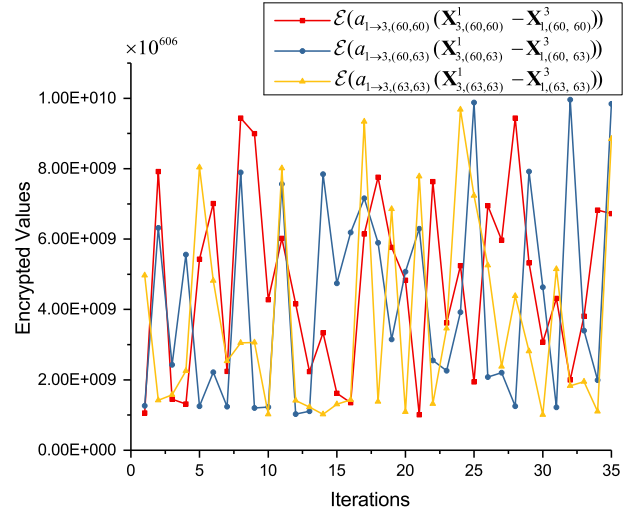

Fig. 5: The evolution of encrypt weighted differences (in ciphertext).

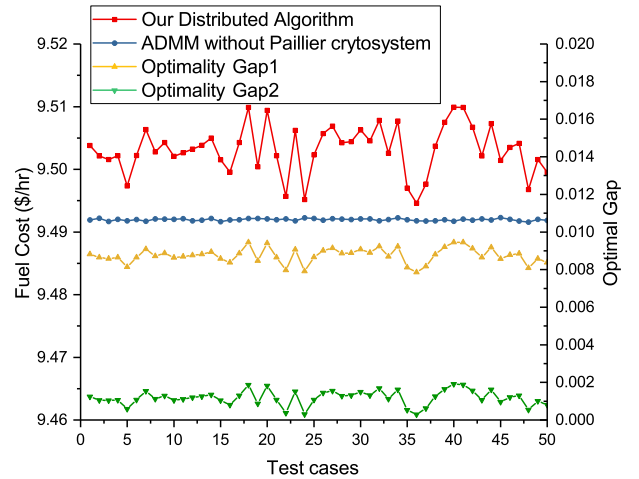

Fig. 6: The optimal values of the proposed algorithm, the ADMM algorithm, and optimal gaps.

$a_{r \rightarrow l}(t)$ ,  $b_{r \rightarrow l}(t)$ ,  $c_{r \rightarrow l}(k)$  and  $d_{r \rightarrow l}(k)$  are also scaled to 64-bit integers, respectively. In particular,  $a_{r \rightarrow l}(t)$ ,  $b_{r \rightarrow l}(t)$ ,  $c_{r \rightarrow l}(k)$  and  $d_{r \rightarrow l}(k)$  are random integers between  $[100, 200]$ .  $\alpha$  in (15) is set to 0.48. Therefore,  $\rho_{rl}$  and  $\kappa_{rl}$  vary between  $[10^4, 4 \times 10^4]$ . The encryption and decryption keys are chosen

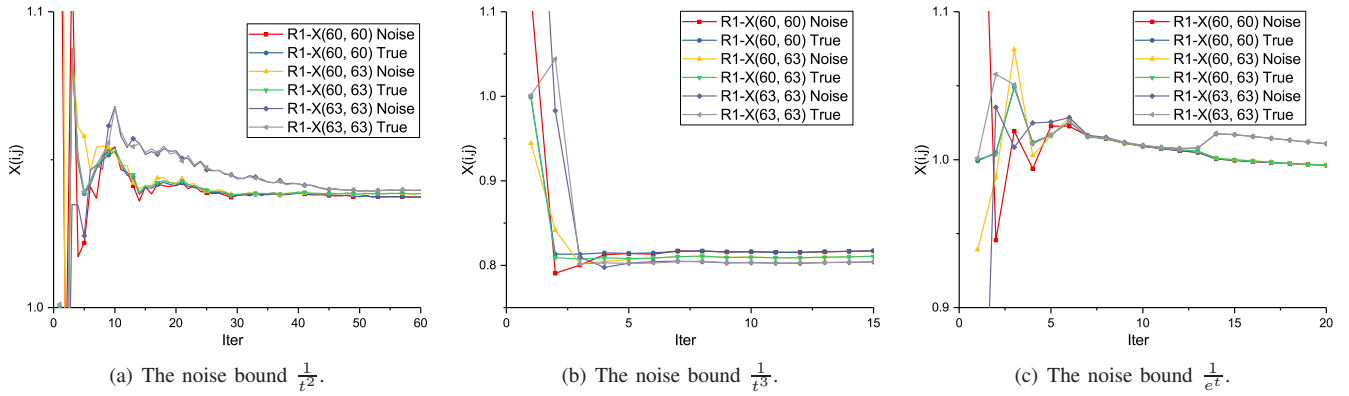

Fig. 7: The evolution of  $\mathbf{X}_{l,o}^r$  in three noise bounds of differential privacy methods.

to be 1028-bit long. All algorithms are executed on a 64-bit Mac with 2.4 GHz (Turbo Boost up to 5.0GHz) 8-Core Intel Core i9 and a total of 16 GB RAM.

### A. Evaluation of Our Approach

Fig. 4 illustrates the evolution of optimal solution of  $\mathbf{X}_{l,o}^r$  in one specific run of Algorithm 3. After 35 iterations, the algorithm converges. Fig. 5 visualizes the encrypted weighted differences (in ciphertext) of the states, i.e.,  $\mathcal{E}(a_{1 \rightarrow 3, (60,60)}(\mathbf{X}_{3, (60,60)}^1 - \mathbf{X}_{1, (60,60)}^3))$ ,  $\mathcal{E}(a_{1 \rightarrow 3, (60,63)}(\mathbf{X}_{3, (60,63)}^1 - \mathbf{X}_{1, (60,63)}^3))$  and  $\mathcal{E}(a_{1 \rightarrow 3, (63,63)}(\mathbf{X}_{3, (63,63)}^1 - \mathbf{X}_{1, (63,63)}^3))$ . Although the states of all agents converge after 36 iterations, the encrypted weighted differences (in ciphertext) are random to an outside eavesdropper. In addition, it takes about 1ms for each agent to finish the encryption/decryption process at each iteration. Such a communication delay can be omitted compared with the time cost of each iteration.

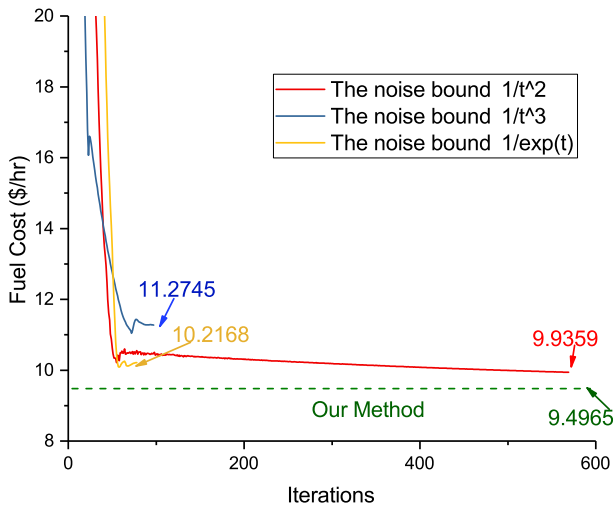

Fig. 8: The evolution of fuel costs under three noise bounds vs the optimal value achieved by our algorithm.

In Fig. 6, we show that the optimality gap of the proposed algorithm is actually small. We first define the optimal solution  $\mathbf{x}^*$  as the solution to (P1) without the rank-1 constraint, which becomes a convex SDP that can be solved in a centralized manner. Due to the tree structure of the network and some

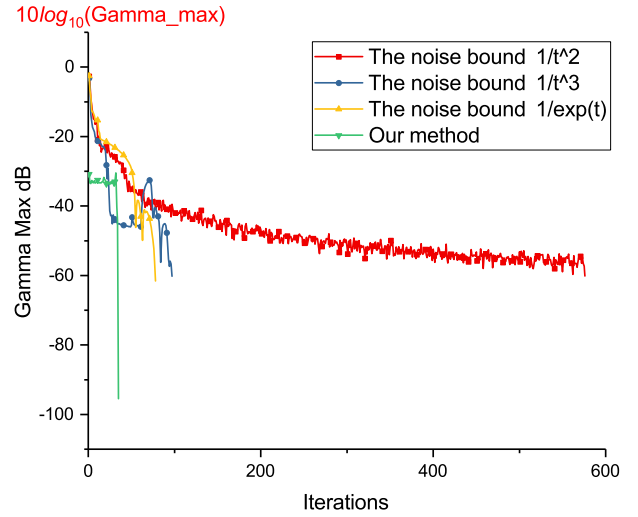

Fig. 9: Convergence of the proposed algorithm VS differential-privacy methods.

other technical conditions being fulfilled, this SDP relaxation is exact. The global optimal solution is solved by the convex optimization solver, i.e., 9.42 \$/hr. We also define the distributed solution  $\mathbf{x}_d^*$  as the solution to (P4) obtained by ADMM without Paillier cryptosystem. The solutions obtained by Algorithms 2&3 are denoted by  $\mathbf{x}_p^*$ . Let us denote  $z^*$  as the optimal value to problem (P1), and  $z_d^*$  and  $z_p^*$  as the near-optimal values corresponding to  $\mathbf{x}_d^*$  and  $\mathbf{x}_p^*$ , respectively. Here, the percentage optimality gap is calculated as  $\text{gap}_1 = 100 \times (z_p^* - z^*)/z_p^* \%$ . Compared with the ADMM without Paillier cryptosystem, the gap is calculated as  $\text{gap}_2 = 100 \times (z_p^* - z_d^*)/z_p^* \%$ . Fig. 6 shows that both  $\text{gap}_1$  and  $\text{gap}_2$  are very small, i.e., on average 0.87540% and 0.11815% for  $\text{gap}_1$  and  $\text{gap}_2$ , respectively. This indicates that the solutions by the proposed algorithms are very close to the global optimum.

### B. Comparison with the Differential-Privacy Algorithm

We then compare our approach with the differential-privacy distributed optimization algorithm. In the differential-privacy distributed optimization algorithm, the messages are added with random noises. For example, a random noise  $n_{l,o}^{r,x,t}$  is added into  $\mathbf{X}_{l,o}^{r,t}$ , denoted by  $\tilde{\mathbf{X}}_{l,o}^{r,t} = \mathbf{X}_{l,o}^{r,t} + n_{l,o}^{r,x,t}$ . Similarly,  $n_{l,o}^{r,z,t}$  is added into  $\mathbf{Z}_{l,o}^{r,t}$ , denoted by  $\tilde{\mathbf{Z}}_{l,o}^{r,t} = \mathbf{Z}_{l,o}^{r,t} + n_{l,o}^{r,z,t}$ . In

[30], both  $n_{l,o}^{r,x,t}$  and  $n_{l,o}^{r,z,t}$  are bounded in  $[-\hat{n}_{l,o}^{r,t}, \hat{n}_{l,o}^{r,t}]$ . The bound  $\hat{n}_{l,o}^{r,t} \in \mathbb{R}^+$  satisfies the following conditions:

$$\sum_{t=0}^{\infty} \hat{n}_{l,o}^{r,t} < \infty, \sum_{t=0}^{\infty} (\hat{n}_{l,o}^{r,t})^2 < \infty. \quad (38)$$

Therefore, we choose three kinds of harmonic series, i.e.,  $\hat{n}_{l,o}^{r,t} = \frac{\hat{n}_{l,o}^{r,0}}{t^2}$ ,  $\hat{n}_{l,o}^{r,t} = \frac{\hat{n}_{l,o}^{r,0}}{t^3}$  and  $\hat{n}_{l,o}^{r,t} = \hat{n}_{l,o}^{r,0} e^{-t}$  for comparison. Fig. 7 visualizes the true messages and the messages with noises. In particular, Fig. 7(a) shows that the differences between the true messages and the messages with noises are obvious before 20 iterations, while messages with noises are very close to the true messages after 20 iterations until convergence. Therefore, both honest-but-curious agents and eavesdroppers can infer the true messages easily. Similarly, other harmonic series are likely to disclose the true messages, as shown in Fig. 7(b) and Fig. 7(c).

Fig. 8 shows that the case with the noise bound  $\frac{\hat{n}_{l,o}^{r,0}}{t^2}$  converges to 9.9359 \$/hr, the case with the noise bound  $\frac{\hat{n}_{l,o}^{r,0}}{t^3}$  converges to 11.2745 \$/hr and the case with the noise bound  $\hat{n}_{l,o}^{r,0} e^{-t}$  converges to 10.2168 \$/hr. In comparison, our algorithm achieves 9.4965 \$/hr of fuel costs, which is very close to the global optimal (i.e., 9.42 \$/hr) with a gap of 0.80556%. This is because the added noises disturb the shared messages and inevitably compromise the accuracy of optimization results, leading to a trade-off between privacy and accuracy.

### C. Convergence of Our Approach

The maximal residue of Algorithm 2 and 3 at the  $t$ th iteration is defined as  $\Psi_{max}^t = \max_{r=1, \dots, R} \Psi_r^t$ . Fig. 9 shows that the cases with noise bounds  $\hat{n}_{l,o}^{r,t} = \frac{\hat{n}_{l,o}^{r,0}}{t^2}$ ,  $\hat{n}_{l,o}^{r,t} = \frac{\hat{n}_{l,o}^{r,0}}{t^3}$  and  $\hat{n}_{l,o}^{r,t} = \hat{n}_{l,o}^{r,0} e^{-t}$  take 79, 97 and 576 iterations to converge, while the proposed algorithm converges within 35 iterations. It indicates that the proposed algorithm converges much faster than the differential-privacy distributed algorithm. This is because that the noise-polluted messages cannot reach a consensus before the noise attenuates to zero.

### D. Comparison with Other Methods

We compare the proposed method with other competing alternatives, namely the distributed SDP method [7], the ADMM method for OPF problems [8], and the relaxed ADMM method [31]. The simulation shows that compared with Ref. [7], the proposed algorithm (PPOPF) only sacrifices a little optimality with only 0.0295% gap to achieve the privacy preservation guarantee. Besides, the proposed algorithm can converge much faster than other benchmark algorithms. It is observed from Table II that the proposed PPOPF method can achieve a better such trade-off, e.g., obvious improvement in convergence rate with minor increase of cost. Moreover, compared with differential-privacy methods, the proposed method obtains the solutions that are closer to the global optimum under a reasonable random penalty range.

TABLE II: PPOPF VS other distributed algorithms

Methods	Cost	Convergence
PPOPF with $\rho_{rl}, \kappa_{rl} \in [10^4, 4.00 \times 10^4]$	9.4946 \$/hr	35 iterations
PPOPF with $\rho_{rl}, \kappa_{rl} \in [10^4, 6.25 \times 10^4]$	9.5029 \$/hr	30 iterations
PPOPF with $\rho_{rl}, \kappa_{rl} \in [10^4, 7.84 \times 10^4]$	9.5260 \$/hr	9 iterations
PPOPF with $\rho_{rl}, \kappa_{rl} \in [10^4, 9.00 \times 10^4]$	9.5575 \$/hr	4 iterations
Distributed SDP [7]	9.4918 \$/hr	48 iterations
ADMM method [8]	9.4402 \$/hr	28 iterations
Relaxed ADMM [31]	9.4917 \$/hr	48 iterations

First of all, we compare the proposed algorithm with the centralized algorithm in terms of computation time. In Fig. 10, we show the computational times for test systems of different sizes under three algorithms. In particular, we connect multiple 85-bus systems to construct large systems with from 85 buses to 1700 buses. Here, we only consider the CPU time spent on the SDP solver and assume that communication overheads can be neglected. In Fig. 10, the sequential distributed algorithm is to sum the CPU times of the subproblems and the parallel distributed algorithm is to consider the longest CPU time of the subproblems in each iteration. The result shows that the proposed distributed algorithm performs much better than the centralized method.

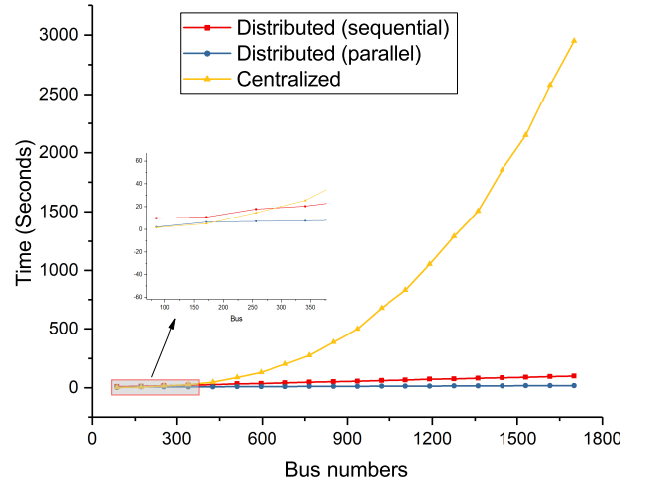

Fig. 10: Time comparison.

## VI. CONCLUSION

This paper proposed a novel privacy-preserving DOPF algorithm based on PHE. The proposed algorithm utilized the ADMM method with the SDP relaxation to solve the OPF problem. For the dual update of the ADMM, we utilized the PHE to encrypt the difference of state variables across neighboring agents. As a result, neither the eavesdroppers nor honest-but-curious agents can infer the exact states. For the primal update, we relaxed the augmented term of the primal update of ADMM with the  $\ell_1$ -norm regularization, and then utilized the sign message communications to enable the privacy-preserving primal update. At last, we proved the privacy preservation guarantee of the proposed algorithm. In addition, numerical case studies showed that the optimality gap of the proposed algorithm is actually small, i.e., only 0.8754%

between the solution obtained by the proposed algorithm and the global optimum. Compared with the differential-privacy distributed optimization methods, the proposed method yields a better solution, and converges much faster.

#### APPENDIX

In the appendix, we prove Proposition 1 and Proposition 2. First of all, let  $d_{g_i}$  be an auxiliary variable, which always equals to one. Obviously,  $d_{g_i}^2 = 1$ ,  $P_{G_i} = P_{G_i} d_{g_i}$  and  $Q_{G_i} = Q_{G_i} d_{g_i}$ . In the meantime, by introducing slack variables  $u_{g_i}$ ,  $l_{g_i}$ ,  $u_{r_i}$ ,  $l_{r_i}$ ,  $u_{b_i}$  and  $l_{b_i}$ , inequality constraints (10) can be transformed into equality constraints as  $u_{g_i}^2 \geq 0$ ,  $l_{g_i}^2 \geq 0$ ,  $u_{r_i}^2 \geq 0$ ,  $l_{r_i}^2 \geq 0$ ,  $u_{b_i}^2 \geq 0$  and  $l_{b_i}^2 \geq 0$ .

#### A. Proposition 1

Problem (15) in region  $r$  can be equivalently written as:

$$\begin{aligned} \arg \min \quad & \sum_{i=1}^{|\mathcal{R}_r^g|} a_i P_{G_i}^2 + b_i P_{G_i} + c_i + \sum_{l \in \mathcal{N}^{\delta(r)}} \\ & \left[ \text{Tr}((\mathbf{\Gamma}_l^r)^T (\mathbf{X}_l^r - \mathbf{X}_l^l)) + \text{Tr}((\mathbf{\Lambda}_l^r)^T (\mathbf{Z}_l^r - \mathbf{Z}_l^l)) \right. \\ & \left. + \alpha \|\text{vec}(\mathbf{X}_l^r - \mathbf{X}_l^l)\|_1 + \alpha \|\text{vec}(\mathbf{Z}_l^r - \mathbf{Z}_l^l)\|_1 \right] \quad (39a) \\ \text{s.t.} \quad & P_{G_i} d_{g_i} - P_{D_i} = \text{Tr}\{\mathbf{Y}_i^r \mathbf{W}^r\}, i \in \mathcal{R}_r^g, \quad (39b) \\ & Q_{G_i} d_{g_i} - Q_{D_i} = \text{Tr}\{\tilde{\mathbf{Y}}_i^r \mathbf{W}^r\}, i \in \mathcal{R}_r^g, \quad (39c) \\ & -P_{D_i} = \text{Tr}\{\mathbf{Y}_i^r \mathbf{W}^r\}, i \in \mathcal{B}_r / \mathcal{R}_r^g, \quad (39d) \\ & -Q_{D_i} = \text{Tr}\{\tilde{\mathbf{Y}}_i^r \mathbf{W}^r\}, i \in \mathcal{B}_r / \mathcal{R}_r^g, \quad (39e) \\ & \text{Tr}\{\mathbf{M}_i^r \mathbf{W}^r\} + u_{b_i}^2 = \bar{V}_i^2, i \in \mathcal{B}_r, \quad (39f) \\ & \text{Tr}\{\mathbf{M}_i^r \mathbf{W}^r\} - l_{b_i}^2 = \underline{V}_i^2, i \in \mathcal{B}_r, \quad (39g) \\ & P_{G_i} d_{g_i} + u_{g_i}^2 = \bar{P}_{G_i}, i \in \mathcal{R}_r^g, \quad (39h) \\ & P_{G_i} d_{g_i} - l_{g_i}^2 = \underline{P}_{G_i}, i \in \mathcal{R}_r^g, \quad (39i) \\ & Q_{G_i} d_{g_i} + u_{r_i}^2 = \bar{Q}_{G_i}, i \in \mathcal{R}_r^g, \quad (39j) \\ & Q_{G_i} d_{g_i} - l_{r_i}^2 = \underline{Q}_{G_i}, i \in \mathcal{R}_r^g, \quad (39k) \\ & d_{g_i}^2 = 1, i \in \mathcal{R}_r^g, \quad (39l) \\ & \mathbf{W}^r \succeq 0. \quad (39m) \end{aligned}$$

We transform the objective (39a) as

$$\begin{aligned} \arg \min \quad & \sum_{i=1}^{|\mathcal{R}_r^g|} a_i P_{G_i}^2 + b_i P_{G_i} + c_i + \sum_{l \in \mathcal{N}^{\delta(r)}} \\ & \left[ \text{Tr}((\mathbf{\Gamma}_l^r + j\mathbf{\Lambda}_l^r)^H \mathbf{W}_l^r) + \alpha \sum_{o \in \mathcal{O}_{r,l}} \right. \\ & \left. (|\mathbf{X}_{l,o}^r - \mathbf{X}_{r,o}^l| + |\mathbf{Z}_{l,o}^r - \mathbf{Z}_{r,o}^l|) \right]. \quad (40a) \end{aligned}$$

Recall that  $\{\mathbf{\Gamma}_l^r(t)\}$  and  $\{\mathbf{\Lambda}_l^r(t)\}$ ,  $\forall t, r, l$  are symmetric and skew-symmetric matrices, respectively. Therefore,  $\text{Tr}((\mathbf{\Gamma}_l^r)^T \mathbf{Z}_l^r)$  and  $\text{Tr}((\mathbf{\Lambda}_l^r)^T \mathbf{X}_l^r)$  are both equal to zeros.

We further define  $\mathbf{N}_{ij}^r = \frac{1}{2}(e_i^r e_j^{rT} + e_j^r e_i^{rT})$  and  $\hat{\mathbf{N}}_{ij}^r = \frac{\sqrt{-1}}{2}(e_i^r e_j^{rT} - e_j^r e_i^{rT})$ , where  $e_i^r$  is the  $i$ th basis vector in  $\mathbb{R}^{|\mathcal{B}_r|}$ . Therefore, Problem (39) is equivalent to

$$\arg \min \quad \sum_{i=1}^{|\mathcal{R}_r^g|} a_i P_{G_i}^2 + b_i P_{G_i} + c_i + \sum_{l \in \mathcal{N}^{\delta(r)}} \left[ \text{Tr}((\mathbf{\Gamma}_l^r + j\mathbf{\Lambda}_l^r)^H \mathbf{W}_l^r) \right.$$

$$\left. + \alpha (\partial_{k,i}^{r,l} \text{Tr}\{\mathbf{M}_i^r \mathbf{W}^r\} + \partial_{k,i,j}^{r,l} \text{Tr}\{\mathbf{M}_j^r \mathbf{W}^r\} + \partial_{k,i,j}^{r,l} \text{Tr}\{\mathbf{N}_{ij}^r \mathbf{W}^r\} + \partial_{k,i,j}^{r,l} \text{Tr}\{\hat{\mathbf{N}}_{ij}^r \mathbf{W}^r\}) \right] \quad (41a)$$

$$\text{s.t.} \quad (39b)-(39m). \quad (41b)$$

where  $\partial_{k,i}^{r,l}$ ,  $\partial_{k,j}^{r,l}$ ,  $\partial_{k,i,j}^{r,l}$  and  $\partial_{k,i,j}^{r,l}$  denote the subgradients of  $|\mathbf{X}_{l,(i,i)}^r - \mathbf{X}_{r,(i,i)}^l|$ ,  $|\mathbf{X}_{l,(j,j)}^r - \mathbf{X}_{r,(j,j)}^l|$ ,  $|\mathbf{X}_{l,(i,j)}^r - \mathbf{X}_{r,(i,j)}^l|$  and  $|\mathbf{Z}_{l,(i,j)}^r - \mathbf{Z}_{r,(i,j)}^l|$  in the  $k$ th iteration, respectively. Note that buses  $i, j$  are the boundary buses and these subgradients are the sign signals from the system operator.

To transform the constraints to SDP, we also introduce some vectors:

1) Group of active powers of generators:

$$x_1 = [P_{G_1}, d_{g_1}, \dots, P_{G_i}, d_{g_i}, \dots], \forall i \in \mathcal{R}_r^g \quad (42)$$

2) Group of reactive powers of generators:

$$x_2 = [Q_{G_1}, d_{g_1}, \dots, Q_{G_i}, d_{g_i}, \dots], \forall i \in \mathcal{R}_r^g \quad (43)$$

3) Group of slack variables for active powers:

$$x_3 = [u_{g_1}, l_{g_1}, \dots, u_{g_i}, l_{g_i}, \dots], \forall i \in \mathcal{R}_r^g \quad (44)$$

4) Group of slack variables for reactive powers:

$$x_4 = [u_{r_1}, l_{r_1}, \dots, u_{r_i}, l_{r_i}, \dots], \forall i \in \mathcal{R}_r^g \quad (45)$$

5) Group of complex voltages:

$$x_5 = [V_1, \dots, V_i, \dots], \forall i \in \mathcal{B}_r \quad (46)$$

6) Group of slack variables for complex voltages:

$$x_6 = [u_{b_1}, l_{b_1}, \dots, u_{b_i}, l_{b_i}, \dots], \forall i \in \mathcal{B}_r \quad (47)$$

Afterward, the SDP variable can be defined by:

$$X = x^H x, \quad (48)$$

where  $x = [x_1, x_2, x_3, x_4, x_5, x_6]$ . Therefore, the matrix  $X$  is positive definite or semidefinite, i.e.,  $X \succeq 0$ . Note that the rank of  $X$  should also be 1. A convex SDP relaxation is obtained by removing the rank constraint. By Theorem 9 of [26], when the cost function is convex and the network is a tree, the SDP relaxation is exact under mild technical conditions.

$$X = \begin{bmatrix} X_1 & \cdots & \cdots & \cdots & \cdots & \cdots \\ \vdots & X_2 & \ddots & \ddots & \ddots & \vdots \\ \vdots & \ddots & X_3 & \ddots & \ddots & \vdots \\ \vdots & \ddots & \ddots & X_4 & \ddots & \vdots \\ \vdots & \ddots & \ddots & \ddots & X_5 & \vdots \\ \vdots & \cdots & \cdots & \cdots & \cdots & X_6 \end{bmatrix}. \quad (49)$$

Note that some elements in  $X$  are replaced with ellipses, indicating that the relevant coefficients of those elements are always zeros. Therefore, the matrix  $X$  can be treated as a

block-diagonal symmetric matrix. In particular,  $X_5 = x_5^H x_5 = (\mathbf{W}^r)^T$ . We define  $X_1, X_2, X_3, X_4$  and  $X_6$  as follows.

$$X_1 = \begin{bmatrix} P_{G_1}^2 & P_{G_1} d_{g_1} & P_{G_1} P_{G_2} & \cdots & \cdots \\ P_{G_1} d_{g_1} & d_{g_1}^2 & \ddots & \ddots & \vdots \\ P_{G_1} P_{G_2} & \ddots & P_{G_2}^2 & \ddots & \vdots \\ \vdots & \ddots & \ddots & d_{g_2}^2 & \vdots \\ \vdots & \cdots & \cdots & \cdots & \cdots \end{bmatrix}. \quad (50)$$

$$X_2 = \begin{bmatrix} Q_{G_1}^2 & Q_{G_1} d_{g_1} & Q_{G_1} P_{G_2} & \cdots & \cdots \\ Q_{G_1} d_{g_1} & d_{g_1}^2 & \ddots & \ddots & \vdots \\ Q_{G_1} P_{G_2} & \ddots & Q_{G_2}^2 & \ddots & \vdots \\ \vdots & \ddots & \ddots & d_{g_2}^2 & \vdots \\ \vdots & \cdots & \cdots & \cdots & \cdots \end{bmatrix}. \quad (51)$$

$$X_3 = \begin{bmatrix} u_{g_1}^2 & u_{g_1} l_{g_1} & u_{g_1} u_{g_2} & u_{g_1} l_{g_2} & \cdots \\ u_{g_1} l_{g_1} & l_{g_1}^2 & \ddots & \ddots & \vdots \\ u_{g_1} u_{g_2} & \ddots & u_{g_2}^2 & \ddots & \vdots \\ u_{g_1} l_{g_2} & \ddots & \ddots & l_{g_2}^2 & \vdots \\ \vdots & \cdots & \cdots & \cdots & \cdots \end{bmatrix}. \quad (52)$$

$$X_4 = \begin{bmatrix} u_{r_1}^2 & u_{r_1} l_{r_1} & u_{r_1} u_{r_2} & u_{r_1} l_{r_2} & \cdots \\ u_{r_1} l_{r_1} & l_{r_1}^2 & \ddots & \ddots & \vdots \\ u_{r_1} u_{r_2} & \ddots & u_{r_2}^2 & \ddots & \vdots \\ u_{r_1} l_{r_2} & \ddots & \ddots & l_{r_2}^2 & \vdots \\ \vdots & \cdots & \cdots & \cdots & \cdots \end{bmatrix}. \quad (53)$$

$$X_6 = \begin{bmatrix} u_{b_1}^2 & u_{b_1} l_{b_1} & u_{b_1} u_{b_2} & u_{b_1} l_{b_2} & \cdots \\ u_{b_1} l_{b_1} & l_{b_1}^2 & \ddots & \ddots & \vdots \\ u_{b_1} u_{b_2} & \ddots & u_{b_2}^2 & \ddots & \vdots \\ u_{b_1} l_{b_2} & \ddots & \ddots & l_{b_2}^2 & \vdots \\ \vdots & \cdots & \cdots & \cdots & \cdots \end{bmatrix}. \quad (54)$$

Ignoring the rank-1 constraint on  $X$ , problem (41) can be relaxed to the primal SDP (24), which is copied here for convenience:

$$\text{Primal: } \arg \min \text{Tr}(A_0(\boldsymbol{\vartheta}))^T X), \quad (55a)$$

$$\text{s.t. } \text{Tr}(A_m^T X) = b_m, \forall m = \{1, \dots, M\} \quad (55b)$$

$$X \succeq 0. \quad (55c)$$

Here, the coefficient matrices  $A_m, m = 1, \dots, M$  have the same dimension as  $X$  and  $\boldsymbol{\vartheta}$  is the set of all sign signals

$\partial_{k,i}^{rl}, \partial_{k,j}^{rl}, \partial_{k,ij}^{rl}$  and  $\partial_{k,\hat{i}\hat{j}}^{rl}, \forall k, i, j, r, l$ . The construction of the matrices  $A_m, m = 1, \dots, M$ , are defined as follows:

$$A_m = \begin{bmatrix} A_{1,m} & \cdots & \cdots & \cdots & \cdots & \cdots \\ \vdots & A_{2,m} & \ddots & \ddots & \ddots & \vdots \\ \vdots & \ddots & A_{3,m} & \ddots & \ddots & \vdots \\ \vdots & \ddots & \ddots & A_{4,m} & \ddots & \vdots \\ \vdots & \ddots & \ddots & \ddots & A_{5,m} & \vdots \\ \vdots & \cdots & \cdots & \cdots & \cdots & A_{6,m} \end{bmatrix}. \quad (56)$$

In order to construct  $A_0$ , we first focus on the fuel cost of generator  $G_i$  on bus  $i$ , i.e.,  $\sum_{i=1}^{|\mathcal{R}_r^g|} a_i P_{G_i}^2 + b_i P_{G_i} + c_i$ . Therefore,  $A_{1,0}$  can be constructed as

$$A_{1,0} = \begin{bmatrix} a_1 & 0.5b_1 & \cdots & \cdots & \cdots & \cdots \\ 0.5b_1 & c_1 & \ddots & \ddots & \vdots & \cdots \\ \vdots & \ddots & \ddots & \ddots & \vdots & \cdots \\ \vdots & \ddots & \ddots & a_i & 0.5b_i & \cdots \\ \vdots & \cdots & \cdots & 0.5b_i & c_i & \cdots \\ \vdots & \cdots & \cdots & \cdots & \cdots & \cdots \end{bmatrix}. \quad (57)$$

In addition, we have  $\text{Tr}((\Gamma_l^r + j\Lambda_l^r)^H \mathbf{W}_l^r)$  for  $l \in \mathcal{N}^{\delta(r)}$ , which can be constructed as

$$A_{5,0}^{l,tr} = \mathbf{E}_{r \rightarrow l}^T (\Gamma_l^r - j\Lambda_l^r) \mathbf{E}_{r \rightarrow l}. \quad (58)$$

Similarly, we define  $A_{5,0}^{l,(i,i)} = \alpha \partial_{k,i}^{rl} \{\mathbf{M}_i^r\}$ ,  $A_{5,0}^{l,(j,j)} = \alpha \partial_{k,j}^{rl} \{\mathbf{M}_j^r\}$ ,  $A_{5,0}^{l,(i,j)} = \alpha \partial_{k,ij}^{rl} \{\mathbf{N}_{ij}^r\}$ ,  $A_{5,0}^{l,(j,i)} = \alpha \partial_{k,\hat{i}\hat{j}}^{rl} \{\hat{\mathbf{N}}_{ij}^r\}$ .

Therefore,  $A_{5,0}$  can be constructed as

$$A_{5,0} = \sum_{l \in \mathcal{N}^{\delta(r)}} \left( A_{5,0}^{l,tr} + \left[ \sum_{o \in \mathcal{O}_{rl}} A_{5,0}^{l,o} \right] \right). \quad (59)$$

In addition,  $A_{2,0}, A_{3,0}, A_{4,0}$ , and  $A_{6,0}$  are zeros matrices.

In the following, we introduce the construction of  $A_i$  corresponding to the constraints. Here, we only consider (39b), (39f), (39h) and (39m). Other constraints can be constructed in a similar way.

For Eq. (39b) with  $P_{G_1}$ , the corresponding  $A_m$  can be constructed as follows:

$$A_{5,m} = -\mathbf{Y}_i^r. \quad (60)$$

In addition, we have

$$A_{1,m} = \begin{bmatrix} \cdots & 0.5 & \cdots & \cdots & \cdots & \cdots \\ 0.5 & \ddots & \ddots & \ddots & \vdots & \cdots \\ \vdots & \ddots & \ddots & \ddots & \vdots & \cdots \\ \vdots & \ddots & \ddots & \ddots & \vdots & \cdots \\ \vdots & \cdots & \cdots & \cdots & \cdots & \cdots \\ \vdots & \cdots & \cdots & \cdots & \cdots & \cdots \end{bmatrix}. \quad (61)$$

Other terms of  $A_m$ , i.e.,  $A_{2,m}$ ,  $A_{3,m}$ ,  $A_{4,m}$ , and  $A_{6,m}$  corresponding to Eq. (55b) are zeros matrices. Accordingly,  $b_m$  in (55b) is  $P_{D_i}$ .

For Eq. (39f) with  $V_1$ , the corresponding  $A_m$  is constructed as follows. First of all, we have

$$A_{5,m} = \mathbf{M}_i^r, \quad (62)$$

and

$$A_{6,m} = \begin{bmatrix} 1 & \cdots & \cdots & \cdots & \cdots & \cdots \\ \cdots & \ddots & \ddots & \ddots & \vdots & \cdots \\ \vdots & \ddots & \ddots & \ddots & \vdots & \cdots \\ \vdots & \ddots & \ddots & \ddots & \cdots & \cdots \\ \vdots & \cdots & \cdots & \cdots & \cdots & \cdots \\ \vdots & \cdots & \cdots & \cdots & \cdots & \cdots \end{bmatrix}. \quad (63)$$

In addition,  $A_{1,m}$ ,  $A_{2,m}$ ,  $A_{3,m}$ , and  $A_{4,m}$  corresponding to Eq. (39f) are zero matrices. Accordingly,  $b_m$  in (55b) is  $V_1^2$ .

For Eq. (39h) with  $P_{G_1}$ , the corresponding  $A_m$  is constructed as

$$A_{1,m} = \begin{bmatrix} \cdots & 0.5 & \cdots & \cdots & \cdots & \cdots \\ 0.5 & \ddots & \ddots & \ddots & \vdots & \cdots \\ \vdots & \ddots & \ddots & \ddots & \vdots & \cdots \\ \vdots & \ddots & \ddots & \ddots & \cdots & \cdots \\ \vdots & \cdots & \cdots & \cdots & \cdots & \cdots \\ \vdots & \cdots & \cdots & \cdots & \cdots & \cdots \end{bmatrix}, \quad (64)$$

and

$$A_{3,m} = \begin{bmatrix} 1 & \cdots & \cdots & \cdots & \cdots & \cdots \\ \cdots & \ddots & \ddots & \ddots & \vdots & \cdots \\ \vdots & \ddots & \ddots & \ddots & \vdots & \cdots \\ \vdots & \ddots & \ddots & \ddots & \cdots & \cdots \\ \vdots & \cdots & \cdots & \cdots & \cdots & \cdots \\ \vdots & \cdots & \cdots & \cdots & \cdots & \cdots \end{bmatrix}. \quad (65)$$

Besides,  $A_{2,m}$ ,  $A_{4,m}$ ,  $A_{5,m}$ , and  $A_{6,m}$  corresponding to Eq. (39h) are zero matrices. Accordingly,  $b_m$  in (55b) is  $\bar{P}_{G_1}$ .

Last, we give  $A_m$  corresponding to Eq. (39m) with  $P_{G_1}$  as

$$A_{1,m} = \begin{bmatrix} 0 & \cdots & \cdots & \cdots & \cdots & \cdots \\ \cdots & 1 & \ddots & \ddots & \vdots & \cdots \\ \vdots & \ddots & \ddots & \ddots & \vdots & \cdots \\ \vdots & \ddots & \ddots & \ddots & \cdots & \cdots \\ \vdots & \cdots & \cdots & \cdots & \cdots & \cdots \\ \vdots & \cdots & \cdots & \cdots & \cdots & \cdots \end{bmatrix}. \quad (66)$$

Moreover,  $A_{2,m}$ ,  $A_{3,m}$ ,  $A_{4,m}$ ,  $A_{5,m}$ , and  $A_{6,m}$  corresponding to Eq. (39m) are zero matrices and  $b_m$  in (55b) is 1.

This completes the proof of Proposition 1.  $\blacksquare$

In the following, we show the equivalence between (40a) and (41a) if the subgradient KKT conditions are employed.

In order to construct  $A'_0$ , we formulate  $A'_{5,0}$  as follows:

$$A'_{5,0} = \sum_{l \in \mathcal{N}^{\delta(r)}} \left( A_{5,0}^{l,tr} \right). \quad (67)$$

Other terms of  $A'_0$  are the same as those of  $A_0$ .

Because (40a) is non-differentiable, subdifferential versions of KKT conditions (Chapter 7 of [32]) are:

$$\partial L_X = A'_0 - \mu X^{-1} - \sum_{m=1}^M A_m y_m - \sum_{l \in \mathcal{N}^{\delta(r)}} \bar{A}_0(\alpha \partial_l^r), \quad (68a)$$

$$\nabla L_y = b_m - \text{Tr}(A_m^T X) = 0, \forall m = \{1, \dots, M\} \quad (68b)$$

where  $A_{5,0}$  of  $\bar{A}_0(\alpha \partial_l^r)$  is denoted by

$$A_{5,0} = \alpha \partial_{k,i}^{r,l} \{\mathbf{M}_i^r\} + \alpha \partial_{k,j}^{r,l} \{\mathbf{M}_j^r\} + \alpha \partial_{k,ij}^{r,l} \{\mathbf{N}_{ij}^r\} + \alpha \partial_{k,\hat{ij}}^{r,l} \{\hat{\mathbf{N}}_{ij}^r\}. \quad (69)$$

Recall that  $A_{5,0}^{l,(i,i)} = \alpha \partial_{k,i}^{r,l} \{\mathbf{M}_i^r\}$ ,  $A_{5,0}^{l,(j,j)} = \alpha \partial_{k,j}^{r,l} \{\mathbf{M}_j^r\}$ ,  $A_{5,0}^{l,(i,j)} = \alpha \partial_{k,ij}^{r,l} \{\mathbf{N}_{ij}^r\}$  and  $A_{5,0}^{l,(j,i)} = \alpha \partial_{k,\hat{ij}}^{r,l} \{\hat{\mathbf{N}}_{ij}^r\}$ . In addition,  $\partial_{k,i}^{r,l} = \pm 1$ ,  $\partial_{k,j}^{r,l} = \pm 1$ ,  $\partial_{k,ij}^{r,l} = \pm 1$  and  $\partial_{k,\hat{ij}}^{r,l} = \pm 1$ . By incorporating all  $\sum_{l \in \mathcal{N}^{\delta(r)}} \bar{A}_0(\alpha \partial_l^r)$  into  $A'_0$ , we can obtain  $A_0$ . Therefore, Problem (41) is equivalent to Problem (39).

### B. Proof of Lemma 1

For all non-zero  $\mathbf{z} = \mathbf{x} + \mathbf{j}\mathbf{y}$  in  $\mathbb{C}^N$  with  $\mathbf{x}$  and  $\mathbf{y}$  in  $\mathbb{R}^N$ , we have

$$\begin{aligned} \mathbf{z}^H \mathbf{W} \mathbf{z} &= (\mathbf{x}^T - \mathbf{j}\mathbf{y}^T)(\mathbf{X} + \mathbf{j}\mathbf{Z})(\mathbf{x} + \mathbf{j}\mathbf{y}) \\ &= \mathbf{x}^T \mathbf{X} \mathbf{x} + \mathbf{y}^T \mathbf{X} \mathbf{y} - \mathbf{x}^T \mathbf{Z} \mathbf{y} + \mathbf{y}^T \mathbf{Z} \mathbf{x} \\ &\quad + \mathbf{j}(\mathbf{x}^T \mathbf{Z} \mathbf{x} + \mathbf{y}^T \mathbf{Z} \mathbf{y} + \mathbf{x}^T \mathbf{X} \mathbf{y} - \mathbf{y}^T \mathbf{X} \mathbf{x}) \end{aligned} \quad (70)$$

It is obviously that  $\mathbf{x}^T \mathbf{Z} \mathbf{x} = 0$  for all non-zero  $\mathbf{x}$  in  $\mathbb{R}^N$  because  $\mathbf{Z}$  is skew-symmetric. Similarly,  $\mathbf{y}^T \mathbf{Z} \mathbf{y} = 0$ . In addition,  $\mathbf{x}^T \mathbf{X} \mathbf{y} - \mathbf{y}^T \mathbf{X} \mathbf{x} = 0$  because  $\mathbf{X}$  is symmetric. Therefore, (70) is reduced into  $\mathbf{x}^T \mathbf{X} \mathbf{x} + \mathbf{y}^T \mathbf{X} \mathbf{y} - \mathbf{x}^T \mathbf{Z} \mathbf{y} + \mathbf{y}^T \mathbf{Z} \mathbf{x}$ .

$$\begin{bmatrix} \mathbf{x} \\ \mathbf{y} \end{bmatrix}^T \begin{bmatrix} \mathbf{X} & -\mathbf{Z} \\ \mathbf{Z} & \mathbf{X} \end{bmatrix} \begin{bmatrix} \mathbf{x} \\ \mathbf{y} \end{bmatrix} = \mathbf{x}^T \mathbf{X} \mathbf{x} + \mathbf{y}^T \mathbf{X} \mathbf{y} - \mathbf{x}^T \mathbf{Z} \mathbf{y} + \mathbf{y}^T \mathbf{Z} \mathbf{x}. \quad (71)$$

Therefore, the semi-definiteness of (70) and (71) can imply each other.

This completes the proof.  $\blacksquare$

### REFERENCES

- [1] J. Lavaei and S. H. Low, "Zero Duality Gap in Optimal Power Flow Problem," *IEEE Trans. Power Syst.*, vol. 27, no. 1, pp. 92–107, 2011.
- [2] T. Wu, Y. J. Zhang, and X. Tang, "A VSC-Based BESS Model for Multi-Objective OPF Using Mixed Integer SOCP," *IEEE Trans. Power Syst.*, vol. 34, no. 4, pp. 2541–2552, 2019.
- [3] V. Dvorkin, P. Van Hentenryck, J. Kazempour, and P. Pinson, "Differentially Private Distributed Optimal Power Flow," *Proceedings of the 59th IEEE Conference on Decision and Control*, 2019.
- [4] H. Wang, J. Zhang, C. Lu, and C. Wu, "Privacy Preserving in Non-Intrusive Load Monitoring: A Differential Privacy Perspective," *IEEE Trans. Smart Grid*, pp. 1–1, 2020.

- [5] J. Liu, Y. Xiao, S. Li, W. Liang, and C. P. Chen, "Cyber security and privacy issues in smart grids," *IEEE Commun. Surveys Tuts.*, vol. 14, no. 4, pp. 981–997, 2012.
- [6] Q. Peng and S. H. Low, "Distributed Optimal Power Flow Algorithm for Radial Networks, I: Balanced Single Phase Case," *IEEE Trans. Smart Grid*, vol. 9, no. 1, pp. 111–121, 2016.
- [7] E. Dall'Anese, H. Zhu, and G. B. Giannakis, "Distributed Optimal Power Flow for Smart Microgrids," *IEEE Trans. Smart Grid*, vol. 4, no. 3, pp. 1464–1475, 2013.
- [8] T. Erseghe, "Distributed Optimal Power Flow using ADMM," *IEEE Trans. Power Syst.*, vol. 29, no. 5, pp. 2370–2380, 2014.
- [9] B. Zhang, A. Y. Lam, A. D. Domínguez-García, and D. Tse, "An Optimal and Distributed Method for Voltage Regulation in Power Distribution Systems," *IEEE Trans. Power Syst.*, vol. 30, no. 4, pp. 1714–1726, 2014.
- [10] C. Lin, W. Wu, and M. Shahidehpour, "Decentralized AC Optimal Power Flow for Integrated Transmission and Distribution Grids," *IEEE Trans. Smart Grid*, vol. 11, no. 3, pp. 2531–2540, 2019.
- [11] M.-M. Zhao, Q. Shi, Y. Cai, M.-J. Zhao, and Y. Li, "Distributed Penalty Dual Decomposition Algorithm for Optimal Power Flow in Radial Networks," *IEEE Trans. Power Syst.*, vol. 35, no. 3, pp. 2176–2189, 2019.
- [12] A. Y. Lam, B. Zhang, and N. T. David, "Distributed Algorithms for Optimal Power Flow Problem," in *2012 IEEE 51st IEEE Conference on Decision and Control (CDC)*. IEEE, 2012, pp. 430–437.
- [13] A. S. Musleh, G. Chen, and Z. Y. Dong, "A Survey on the Detection Algorithms for False Data Injection Attacks in Smart Grids," *IEEE Trans. Smart Grid*, vol. 11, no. 3, pp. 2218–2234, 2019.
- [14] S. Han, U. Topcu, and G. J. Pappas, "Differentially Private Distributed Constrained Optimization," *IEEE Trans. Autom. Control*, vol. 62, no. 1, pp. 50–64, 2016.
- [15] V. Dvorkin, F. Fioretto, P. Van Hentenryck, P. Pinson, and J. Kazempour, "Differentially private optimal power flow for distribution grids," *IEEE Trans. Power Syst.*, 2020.
- [16] T. W. Mak, F. Fioretto, L. Shi, and P. Van Hentenryck, "Privacy-Preserving Power System Obfuscation: A Bilevel Optimization Approach," *IEEE Trans. Power Syst.*, vol. 35, no. 2, pp. 1627–1637, 2019.
- [17] Y. Lu and M. Zhu, "Privacy Preserving Distributed Optimization using Homomorphic Encryption," *Automatica*, vol. 96, pp. 314–325, 2018.
- [18] C. Zhang and Y. Wang, "Enabling Privacy-Preservation in Decentralized Optimization," *IEEE Trans. Control Netw. Syst.*, vol. 6, no. 2, pp. 679–689, 2018.
- [19] C. Zhang, M. Ahmad, and Y. Wang, "ADMM based Privacy-Preserving Decentralized Optimization," *IEEE Trans. Inf. Forensics Security*, vol. 14, no. 3, pp. 565–580, 2018.
- [20] Z. Zhang, P. Cheng, J. Wu, and J. Chen, "Secure state estimation using hybrid homomorphic encryption scheme," *IEEE Trans. Control Syst. Technol.*, 2020.
- [21] A. B. Alexandru, K. Gatsis, Y. Shoukry, S. A. Seshia, P. Tabuada, and G. J. Pappas, "Cloud-based quadratic optimization with partially homomorphic encryption," *IEEE Trans. Autom. Control*, 2020.
- [22] J. Yu, Y. Weng, and R. Rajagopal, "Patopa: A data-driven parameter and topology joint estimation framework in distribution grids," *IEEE Trans. Smart Grid*, vol. 33, no. 4, pp. 4335–4347, 2017.
- [23] X. Liu and Z. Li, "False Data Attacks against AC State Estimation with Incomplete Network Information," *IEEE Trans. Smart Grid*, vol. 8, no. 5, pp. 2239–2248, 2016.
- [24] T. Wu, C. Zhao, and Y. J. Zhang, "Distributed AC-DC Optimal Power Dispatch of VSC-Based Energy Routers in Smart Microgrids," *IEEE Trans. Power Syst.*, 2021.
- [25] P. Paillier, "Public-key Cryptosystems based on Composite Degree Residuosity Classes," in *International conference on the theory and applications of cryptographic techniques*. Springer, 1999, pp. 223–238.
- [26] S. H. Low, "Convex Relaxation of Optimal Power Flow—Part II: Exactness," *IEEE Trans. Control Netw. Syst.*, vol. 1, no. 2, pp. 177–189, 2014.
- [27] R. Grone, C. R. Johnson, E. M. Sá, and H. Wolkowicz, "Positive Definite Completions of Partial Hermitian Matrices," *Linear Algebra and its Applications*, vol. 58, pp. 109–124, 1984.
- [28] S. Boyd, S. P. Boyd, and L. Vandenberghe, *Convex optimization*. Cambridge university press, 2004.
- [29] X. Bai, H. Wei, K. Fujisawa, and Y. Wang, "Semidefinite Programming for Optimal Power Flow Problems," *International Journal of Electrical Power & Energy Systems*, vol. 30, no. 6-7, pp. 383–392, 2008.
- [30] S. Mao, Y. Tang, Z. Dong, K. Meng, Z. Y. Dong, and F. Qian, "A Privacy Preserving Distributed Optimization Algorithm for Economic Dispatch Over Time-Varying Directed Networks," *IEEE Trans. Ind. Informat.*, vol. 17, no. 3, pp. 1689–1701, 2021.
- [31] N. Bastianello, R. Carli, L. Schenato, and M. Todescato, "Asynchronous distributed optimization over lossy networks via relaxed admm: Stability and linear convergence," *IEEE Trans. Autom. Control*, pp. 1–1, 2020.
- [32] A. Ruszczyński, *Nonlinear optimization*. Princeton university press, 2011.



**Tong Wu** (Student Member, IEEE) is currently working toward the Ph.D. degree in the Department of Information Engineering, The Chinese University of Hong Kong, Hong Kong. His research interests include machine learning and distributed optimization in smart grids. He is also interested in graph representation learning and statistical learning.



**Changhong Zhao** (Member, IEEE) is an Assistant Professor with the Department of Information Engineering, the Chinese University of Hong Kong. He received B.E. degree in automation from Tsinghua University, Beijing, China, in 2010, and M.S. and Ph.D. degrees in electrical engineering from California Institute of Technology, Pasadena, CA, USA, in 2012 and 2016, respectively. From 2016 to 2019, he worked with the National Renewable Energy Laboratory, Golden, CO, USA. His research is on control and optimization of network systems such as smart grid. He received Demetriades Prize and Wilts Prize for best Ph.D. thesis from Caltech EAS Division and EE Department, respectively, and Early Career Award from Hong Kong Research Grants Council.



**Ying-Jun Angela Zhang** (Fellow, IEEE) is currently a Professor at The Chinese University of Hong Kong. She received her Ph.D. degree from The Hong Kong University of Science and Technology. She has published actively in the area of wireless communication systems and smart power grid, and received several Best Paper Awards, including the IEEE Marconi Prize Paper Award in Wireless Communications. She is a Fellow of IET, IEEE and a Distinguished Lecturer of IEEE ComSoc.

She is currently a Member of IEEE ComSoc Fellow Evaluation Committee and an Associate Editor-in-Chief of IEEE Open Journal of the Communications Society. She is on the Steering Committees of IEEE Wireless Communications Letters and IEEE SmartgridComm Conference. Previously, she served as the Chair of Executive Editorial Committee of IEEE Transactions on Wireless Communications, and the Founding Chair of IEEE Smart Grid Communications Technical Committee. She has been a Technical Program/Symposium Co-Chair of IEEE ICC/GC Conferences multiple times.