

Secure Identification for Gaussian Channels and Identification for Multi-Antenna Gaussian Channels

Wafa Labidi, Christian Deppe and Holger Boche, *Fellow, IEEE*

Abstract—New applications in modern communications are demanding robust and ultra-reliable low latency information exchange such as machine-to-machine and human-to-machine communications. For many of these applications, the identification approach of Ahlswede and Dueck is much more efficient than the classical message transmission scheme proposed by Shannon. Previous studies concentrate mainly on identification over discrete channels. For discrete channels, it was proved that identification is robust under channels uncertainty. Furthermore, optimal identification schemes that are secure and robust against jamming attacks have been considered. However, no results for continuous channels have yet been established. That is why we focus on the continuous case: the Gaussian channel for its known practical relevance. We deal with secure identification over Gaussian channels. Provable secure communication is of a high interest for future communication systems. A key technique for implementing secure communication is the physical layer security based on information theoretic security. We model this with the wiretap channel. In particular, we provide a suitable coding scheme for the Gaussian wiretap channel (GWC) and determine the corresponding secure identification capacity. We also consider Multiple-Input Multiple-Output (MIMO) Gaussian channels and provide an efficient signal-processing scheme. This scheme allows a separation of signal-processing and Gaussian coding.

Index Terms—Identification theory, information theoretic security, Gaussian channels

I. INTRODUCTION

IN the classical transmission scheme proposed by Shannon [2], the encoder transmits a message over a channel and at the receiver side, the decoder aims to estimate this message based on the channel observation. However, this is not the case for identification, a new approach in communications suggested by Ahlswede and Dueck [3] in 1989. This new problem with semantic aspect has enlarged the basis of information theory. In the identification scheme, the encoder sends an identification message (called also identity) over the channel and the decoder is not interested in *what* the received message is, but wants to know *whether* a specific message, in which the receiver is interested, has been sent or not. Naturally,

This work was supported by the Deutsche Forschungsgemeinschaft (DFG, German Research Foundation) under Germany's Excellence Strategy - EXC 2092 CASA - 390781972 and the German Federal Ministry of Education and Research (BMBF) within the national initiative for "Post Shannon Communication (NewCom)" under Grants 16KIS1005. W. and 16KIS1003K.

The material of this paper will be presented in part at the 2020 IEEE International Conference on Acoustics, Speech, and Signal Processing [1].

Holger Boche and Wafa Labidi are with the Lehrstuhl für Theoretische Informationstechnik, Technische Universität München, 80333 Munich, Germany (e-mail: boche@tum.de; wafa.labidi@tum.de). Christian Deppe is with the Lehrstuhl für Nachrichtentechnik, Technische Universität München, 80333 Munich, Germany (e-mail: christian.deppe@tum.de).

the sender has no knowledge of this message the receiver is interested in. One can assume the existence of a set of events (double exponential in the blocklength) $\{E_1, \dots, E_N\}$, where any one of them may occur with a certain probability and is only known by the sender. The receiver is focused on an event E_i and wants to know *whether or not* E_i occurred. In this perspective, the identification problem can be regarded as a testing of many hypothesis test problems occurring simultaneously. One of the main results in the theory of identification for Discrete Memoryless Channels (DMCs) is that the size of identification codes grows doubly exponentially fast with the blocklength. This is different from the classical transmission, where the number of messages that can be reliably communicated over the channel is exponential in the blocklength. Furthermore, contrary to Shannon transmission, randomized encoding is essential for identification to achieve the double exponential growth.

It has been thought that the identification problem is just a generalization of the classical transmission. However, this conjecture has been disproved in [4] and [5]. Although feedback does not increase the transmission capacity of a DMC, it does increase the identification capacity [4]. Furthermore, it has been shown in [5] that the correlation-assisted identification capacity has a completely different behavior than the task of message transmission.

Identification is an increasingly important area in communications, which has been extensively studied over the past decades. Recently, it has emerged that the identification scheme is more efficient in many communication scenarios. Indeed, the new applications demand ultra-reliable low latency such as machine-to-machine and human-to-machine systems [6], the tactile internet [7], etc. As mentioned in [7], security and latency requirements have to be physically embedded. In this situation [6], the classical transmission is limited and an identification scheme is much more efficient. Furthermore, there has been an increasing interest in providing schemes for secure identification over noisy channels. For instance, Ahlswede and Zhang focused in [8] on identification over the discrete wiretap channel, which is a basic model considered in information-theoretic security. It was demonstrated that, in contrast to secure transmission, the identification capacity of the wiretap channel coincides with the capacity of the main channel; the channel from the legitimate sender to the legitimate receiver. However, this is true only if it is possible to transmit data securely over the channel. Previous work on identification focused on channels with finite input and output alphabets. Only a few studies [9], [10] have explored identification for continuous alphabets. We are concerned with

a continuous case: the Gaussian channel due to its practical relevance. Indeed, the Gaussian channel is a good model for many communication situations, e.g., satellite and deep space communication links, wired and wireless communications, etc. The transition from the discrete case to the continuous one is not obvious. Burnashev [10] has shown that for the white Gaussian channel without bandwidth constraint and finite Shannon capacity, the corresponding identification capacity is infinite.

Secure identification for discrete alphabets has been extensively studied [6], [11], [12] over the recent decades due to its important potential use in many future scenarios. Indeed, for discrete channels, it was proved in [11] that secure identification is robust under channel uncertainty and against jamming attacks. Although many researchers are now addressing the problem of secure identification for continuous alphabets, no results have yet been established. This raises the question whether secure identification can be reached for continuous channels. This still remains an open problem. We completely solve the Gaussian case by giving the secure identification capacity of the Gaussian wiretap channel (GWC). The wiretapper, in contrast to the discrete case, is not limited anymore and has infinite alphabet. This is advantageous for the wiretapper since he has no limit on the hardware resolution. This means that the received signal can be resolved with infinite accuracy. Existing cryptographic approaches commonly used for wireless local area networks can be broken sufficient computing power. In contrast, information theory provides a tool for designing codes for a specific model that are proven to be unbreakable. We consider information theoretical security. In our coding scheme the authorized sender wants to transmit a secure identification message to the authorized receiver so that the receiver is able to identify his message. The unauthorized party is a wiretapper who can wiretap the transmission. He tries to identify an unknown message. We have developed a coding scheme so that secure identification over a Gaussian channel is possible. The receiver can identify a message with high probability. Furthermore, the wiretapper is not able to identify a message with high probability. The secure identification capacity of the wiretap channel was only determined in the discrete case [8]. In our paper, we compute the secure identification capacity for the GWC, which is a key metric to assess security level of an identification scheme. In our paper, we use the results about semantic security for Gaussian channels established in [13].

In Section II, we introduce the channel model, the definitions and the main results for transmission and identification over wiretap channels. In Section III, we provide a coding scheme for a secure identification over the GWC and prove the dichotomy theorem for this case. In Section IV, we use the Single-Input Single-Output (SISO) Gaussian results to complete the proofs for the MIMO case and elaborate an effective MIMO signal-processing scheme. In Section V, we consider an identification scheme with a common randomness resource and derived a lower bound on the correlation-assisted capacity. Section VI contains concluding remarks and proposes potential future research in this field.

II. PRELIMINARIES

In this section, we introduce the channel models and the notation that will be used throughout the paper. We also recall some basic definitions and known results about classical transmission as well as identification over DMCs.

A. Notation

\mathbb{R} denotes the sets of real numbers; $H(\cdot)$, $I(\cdot;\cdot)$ are the entropy and mutual information, respectively; H_2 denotes the binary entropy; $d(P, Q) = \sup_{\mathcal{A} \subset \mathcal{F}} |P(\mathcal{A}) - Q(\mathcal{A})|$ denotes the total variation distance between two probability distributions P and Q on (Ω, \mathcal{F}) ; all logarithms and information quantities are taken to the base 2; the set of probability distributions on the set \mathcal{A} is denoted by $\mathcal{P}(\mathcal{A})$; $\|\mathbf{a}\|$ denotes the L_1 norm of a vector \mathbf{a} ; \mathbf{A}^H stands for the Hermitian transpose of the matrix \mathbf{A} .

B. Definitions and Auxiliary Results

We first start with the discrete case and we then characterize the secure identification capacity for the Gaussian channel.

Definition 1. A discrete memoryless channel (DMC) is a triple $(\mathcal{X}, \mathcal{Y}, W)$, where \mathcal{X} and \mathcal{Y} are finite sets denoted as input- respectively output alphabet, and $W = \{W(y|x) : x \in \mathcal{X}, y \in \mathcal{Y}\}$ is a stochastic matrix. The probability for a sequence $\mathbf{y}^n = (y_1, \dots, y_n) \in \mathcal{Y}^n$ to be received if $\mathbf{x}^n = (x_1, \dots, x_n) \in \mathcal{X}^n$ was sent is defined by

$$W^n(\mathbf{y}^n | \mathbf{x}^n) = \prod_{t=1}^n W(y_t | x_t),$$

where n is the number of channel uses.

Ahlswede and Dueck defined in [3] identification codes for a DMC as the following.

Definition 2. A deterministic $(n, N, \lambda_1, \lambda_2)$ identification code for a DMC W is a family of pairs $\{(u_i, \mathcal{D}_i), i = 1, \dots, N\}$ with

$$u_i \in \mathcal{X}^n, \quad \mathcal{D}_i \subset \mathcal{Y}^n, \quad \forall i \in \{1, \dots, N\}$$

such that for $\lambda_1 + \lambda_2 < 1$ we have:

$$W^n(\mathcal{D}_i^c | u_i) \leq \lambda_1 \quad \forall i, \quad (1)$$

$$W^n(\mathcal{D}_j | u_i) \leq \lambda_2 \quad \forall i \neq j. \quad (2)$$

Ahlswede and Dueck established in [3] the identification capacity with randomized encoding because local randomness at the encoder is essential to achieve a double exponential growth of the number of identities. In the deterministic setup, the number of identities scales only exponentially. That is why we consider randomized identification codes in the following. Deterministic identification capacity in the exponential scale has been studied in [14], [15].

Definition 3. A randomized $(n, M, \lambda_1, \lambda_2)$ identification code for a DMC W is a family of pairs $\{(Q(\cdot|i), \mathcal{D}_i), i = 1, \dots, N\}$ with

$$Q(\cdot|i) \in \mathcal{P}(\mathcal{Y}^n), \quad \mathcal{D}_i \subset \mathcal{Y}^n, \quad \forall i \in \{1, \dots, N\}$$

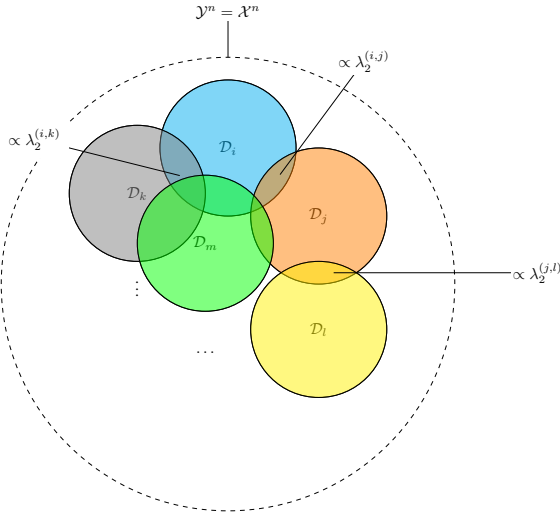

Fig. 1: Example of decoding sets of an identification code for a noiseless binary channel

such that for $\lambda_1 + \lambda_2 < 1$ we have:

$$\sum_{x^n \in \mathcal{X}^n} Q(x^n|i)W^n(\mathcal{D}_i^c|x^n) \leq \lambda_1 \quad \forall i, \quad (3)$$

$$\sum_{x^n \in \mathcal{X}^n} Q(x^n|j)W^n(\mathcal{D}_i|x^n) \leq \lambda_2. \quad (4)$$

One of the main results in identification theory is the identification coding theorem proved by Ahlswede and Dueck. Contrary to transmission, where the number of messages that can be reliably communicated over the channel is exponential in the blocklength, the size of identification codes grows doubly exponentially fast with the blocklength. Han and Verdú proved the strong converse in [16].

Theorem 1. [3], [16] Let W be a finite DMC, $N(n, \lambda)$ the maximal number such that an $(n, N, \lambda_1, \lambda_2)$ identification code for W exists with $\lambda_1, \lambda_2 \leq \lambda$, and let $C(W)$ be the Shannon capacity of W then:

$$C_{ID}(W) \triangleq \lim_{n \rightarrow \infty} \frac{1}{n} \log \log N(n, \lambda) = C(W) \quad \text{for } \lambda \in (0, \frac{1}{2}),$$

where $C_{ID}(W)$ denotes the identification capacity of the DMC W .

Remark 1. In contrast to transmission over DMCs, randomization is essential to achieve the identification capacity. With randomization, we obtain both maximal error probabilities for each identification message and the double exponential growth of code sizes. We can also achieve this double exponential growth of the code size by using deterministic codes and by considering rather the average error probability (see [17]). However, in practice, it is necessary to consider the maximal error for each message. That is why we consider identification with local randomness at the encoder. In the sequel, we will stick to randomized identification codes. An example of decoding sets of an identification code for a noiseless binary channel is depicted in Fig. 1. It is worth mentioning that channel noise can lead to an error of the second kind. For

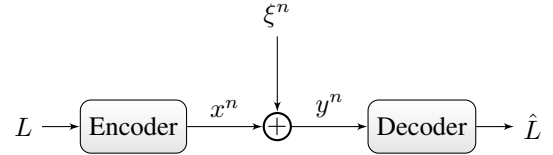

Fig. 2: Discrete-time Gaussian channel

that reason, we consider an example of a noiseless channel to better recognize the error implied by the code construction.

Definition 4. The discrete-time Gaussian channel is a triple $(\mathcal{X}, \mathcal{Y}, W_g)$, where \mathcal{X} and \mathcal{Y} are infinite sets denoted as input-respectively output alphabet, and

$$W_g = \{W_g(y|x) = \frac{1}{\sqrt{2\pi\sigma^2}} \exp\left(-\frac{(y-x)^2}{2\sigma^2}\right), x \in \mathcal{X}, y \in \mathcal{Y}\}$$

is a stochastic matrix. We have:

$$y_i = x_i + \xi_i, \quad \forall i \in \{1, \dots, n\}, \quad (5)$$

where $x^n = (x_1, x_2, \dots, x_n) \in \mathcal{X}^n \subset \mathbb{R}^n$ and $y^n = (y_1, y_2, \dots, y_n) \in \mathcal{Y}^n \subset \mathbb{R}^n$ are the channel input and output blocks, respectively. $\xi^n = (\xi_1, \xi_2, \dots, \xi_n)$ is the noise sequence, where ξ_i are independent and identically distributed (i.i.d) for $i \in \{1, \dots, n\}$. Each noise sample ξ_i , $i = 1, \dots, n$ is drawn from a normal distribution denoted by g with variance σ^2 . If the noise variance is zero or the input is unconstrained, the capacity of the channel is infinite. The most common limitation on the input is a power constraint:

$$\frac{1}{n} \sum_{i=1}^n x_i^2 \leq P. \quad (6)$$

The Gaussian channel is depicted in Fig. 2. L is the message sent over the Gaussian channel and \hat{L} is the output of the decoder.

It follows from (6) that each input sequence x^n lies in the new constrained input set $\mathcal{X}_{n,P}$ defined as follows.

$$\mathcal{X}_{n,P} = \left\{ x^n \in \mathcal{X}^n \subset \mathbb{R}^n : \sum_{i=1}^n x_i^2 \leq n \cdot P \right\}. \quad (7)$$

We extend the definitions of a transmission code and an identification code to the Gaussian channel W_g .

Definition 5. A randomized (n, M, λ) transmission code for the Gaussian channel W_g is a family of pairs $\{(Q(\cdot|i), \mathcal{D}_i), i = 1, \dots, M\}$ with

$$Q(\cdot|i) \in \mathcal{P}(\mathcal{X}_{n,P}), \quad \mathcal{D}_i \subset \mathcal{Y}^n$$

such that for all $i \neq j$

$$\mathcal{D}_i \cap \mathcal{D}_j = \emptyset \quad (8)$$

, for all i and $\lambda \in (0, 1)$

$$\int_{x^n \in \mathcal{X}_{n,P}} Q(x^n|i)(x^n)W_g^n(\mathcal{D}_i|x^n)d^n x^n \geq 1 - \lambda. \quad (9)$$

Definition 6. A randomized $(n, N, \lambda_1, \lambda_2)$ identification code for the Gaussian channel W_g is a family of pairs $\{(Q(\cdot|i), \mathcal{D}_i), i = 1, \dots, N\}$ with

$$Q(\cdot|i) \in \mathcal{P}(\mathcal{X}_{n,P}), \quad \mathcal{D}_i \subset \mathcal{Y}^n, \quad \forall i \in \{1, \dots, N\}$$

such that for all $i, j \in \{1, \dots, N\}, i \neq j$ and $\lambda_1 + \lambda_2 < 1$

$$\int_{x^n \in \mathcal{X}_{n,P}} Q(x^n|i) W_g^n(\mathcal{D}_i^c|x^n) d^n x^n \leq \lambda_1, \quad (10)$$

$$\int_{x^n \in \mathcal{X}_{n,P}} Q(x^n|j) W_g^n(\mathcal{D}_i|x^n) d^n x^n \leq \lambda_2. \quad (11)$$

Definition 7. Let $(\mathcal{X}_{n,P}, \mathcal{Y}, W_g)$ be a discrete-time Gaussian channel.

- 1) The rate R of an $(n, N, \lambda_1, \lambda_2)$ identification code for W_g is $R = \frac{\log \log(N)}{n}$ bits.
- 2) The identification rate R for W_g is said to be achievable if for $\lambda \in (0, 1)$ there exists an $n_0(\lambda)$, such that for all $n \geq n_0(\lambda)$ there exists an $(n, 2^{2^{nR}}, \lambda, \lambda)$ identification code for W_g .
- 3) The identification capacity $C_{ID}(g, P)$ of a Gaussian channel W_g is the supremum of all achievable rates.

The identification coding theorem is extended to the Gaussian case. It is worth pointing out that the direct part is similar in spirit to the discrete case. For more details, we refer the reader to [18]. The converse part is established in [10].

Theorem 2. [10] Let $N(n, \lambda)$ be the maximal number such that an $(n, N, \lambda_1, \lambda_2)$ identification code for the channel W_g exists with $\lambda_1, \lambda_2 \leq \lambda$ and $\lambda \in (0, \frac{1}{2})$ then:

$$C_{ID}(g, P) \triangleq \lim_{n \rightarrow \infty} \frac{1}{n} \log \log N(n, \lambda) = C(g, P),$$

where $C(g, P)$ denotes the Shannon capacity of W_g and is given by:

$$C(g, P) = \frac{1}{2} \log\left(1 + \frac{P}{\sigma^2}\right)$$

The wiretap channel was first studied by Wyner in [19]. It is considered as a basic model in information-theoretic security, where a transmitter (Alice) wants to send a message L , uniformly distributed on the set of messages, to the legitimate receiver (Bob) who outputs the estimation \hat{L} and L should be kept in secret from an eavesdropper (Eve). The eavesdropper is assumed to be a passive receiver.

Definition 8. A discrete memoryless wiretap channel is a quintuple $(\mathcal{X}, \mathcal{Y}, \mathcal{Z}, W, V)$, where \mathcal{X} is the finite input alphabet, \mathcal{Y} is the finite output alphabet for the legitimate receiver, \mathcal{Z} is the finite output alphabet for the wiretapper, $W = \{W(y|x) : x \in \mathcal{X}, y \in \mathcal{Y}\}$ is the set of the transmission matrices whose output is available to the legitimate receiver, and $V = \{V(z|x) : x \in \mathcal{X}, z \in \mathcal{Z}\}$ is the set of transmission matrices whose output is available to the wiretapper. For notational simplicity, we denote the wiretap channel with the pair (W, V) .

Let Y denote the output of the channel W with distribution P_Y on \mathcal{Y} and Z the output of the channel V with distribution P_Z on \mathcal{Z} . Wyner [19] determined the secrecy capacity when

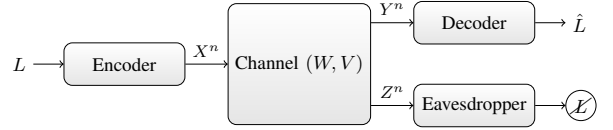

Fig. 3: A wiretap channel

the channel is physically degraded, i.e., when $X - Y - Z$ is a Markov chain and under weak secrecy criterion. Wyner introduced in [19] transmission wiretap codes, which are transmission codes fulfilling a secrecy requirement. Csiszár and Körner [20] extended the results for the non degraded case depicted in Fig. 3. The channel has two outputs: One is for the legitimate receiver and the other is for the eavesdropper. As mentioned before, L should be kept in secret from the eavesdropper. Thus, we have a secrecy requirement (in this paper, we restrict our attention to strong secrecy).

$$I(L; Z^n) \leq \delta_1 \quad \text{with } \delta_1 > 0, \quad (12)$$

where Z^n is the output to the eavesdropper. The legitimate receiver should be able to decode his message with small error probability $P_e^{(n)}$.

$$P_e^{(n)} \triangleq \Pr[\hat{L} \neq L] \leq \delta_2 \quad \text{with } \delta_2 > 0. \quad (13)$$

It is to note that $L \circlearrowleft X^n \circlearrowleft Y^n Z^n$ forms a Markov chain.

Definition 9. A randomized (n, M, λ) transmission-code for wiretap channel (V, W) is a family of pairs $\{(Q(\cdot|i), \mathcal{D}_i), i = 1, \dots, M\}$ such that for all $i \in \{1, \dots, M\}$ and some $\lambda \in (0, 1)$ we have:

$$Q(\cdot|i) \in \mathcal{P}(\mathcal{X}^n), \quad \mathcal{D}_i \subset \mathcal{Y}^n \quad (14)$$

$$\sum_{x^n \in \mathcal{X}^n} Q(x^n|i) W^n(\mathcal{D}_i^c|x^n) \leq \lambda \quad (15)$$

$$\mathcal{D}_i \cap \mathcal{D}_j = \emptyset, \quad \forall i \neq j \quad (16)$$

$$I(U, Z^n) \leq \lambda \quad (17)$$

where U is a uniformly distributed RV on $\{1, \dots, M\}$ and Z^n is the output of the channel V i.e., the wiretapper's observation.

Let $M(n, \lambda)$ be the maximum number such that an (n, M, λ) code for the wiretap channel (W, V) exists. The secrecy capacity of (W, V) is defined as $C_S(W, V)$ and is the maximum of all achievable secrecy rates. A secrecy rate R for (W, V) is said to be achievable if for all $n \geq n_0(\lambda)$, we have $M(n, \lambda) \geq 2^{n(R-\lambda)}$. The following result is shown in [21].

Theorem 3 ([21]).

$$C_S(W, V) = \max_{U \circlearrowleft X \circlearrowleft YZ} I(U, Y) - I(U, Z),$$

where Y is the resulting random variable at the output of legal receiver channel and Z is the resulting random variable at the output of wiretap channel. The maximum is taken over all random variables that satisfy the Markov chain relationship $U \circlearrowleft X \circlearrowleft YZ$

Ahlsvede and Zhang defined in [8] identification codes for discrete wiretap channels as follows.

Definition 10. A randomized $(n, N, \lambda_1, \lambda_2)$ identification code for a wiretap channel (W, V) is a family of pairs $\{(Q(\cdot|i), \mathcal{D}_i), i = 1, \dots, N\}$ with

$$Q(\cdot|i) \in \mathcal{P}(\mathcal{X}^n), \quad \mathcal{D}_i \subset \mathcal{Y}^n, \quad \forall i \in \{1, \dots, N\}$$

such that for all $i, j \in \{1, \dots, N\}, i \neq j$ and some $\mathcal{E} \subset \mathcal{Z}^n$

$$\sum_{x^n \in \mathcal{X}^n} Q(x^n|i) W^n(\mathcal{D}_i|x^n) \geq 1 - \lambda_1, \quad (18)$$

$$\sum_{x^n \in \mathcal{X}^n} Q(x^n|j) W^n(\mathcal{D}_i|x^n) \leq \lambda_2, \quad (19)$$

$$\begin{aligned} & \sum_{x^n \in \mathcal{X}^n} Q(x^n|j) V^n(\mathcal{E}|x^n) \\ & + \sum_{x^n \in \mathcal{X}^n} Q(x^n|i) V^n(\mathcal{E}^c|x^n) \geq 1 - \lambda, \quad (20) \end{aligned}$$

where $\lambda \in (0, 1)$. We denote with $N_S(n, \lambda)$ the maximum number such that an $(n, N, \lambda_1, \lambda_2)$ identification wiretap code for the channel (W, V) exists.

It was shown in [22] that (20) implies strong secrecy. (20) is called the distinguish-ability criterion, i.e., the eavesdropper would not be able to distinguish between the identities i and j .

- The secure identification rate R of a wiretap channel is said to be achievable if for all $\lambda \in (0, 1)$ there exists a $n(\lambda)$, such that for all $n \geq n(\lambda)$ there exists an (n, N, λ, λ) wiretap identification code. In this case, $\lambda_1 = \lambda_2 = \lambda$.
- The secure identification capacity $C_{SID}(W, V)$ of a wiretap channel (W, V) is the supremum of all achievable rates.

Ahlsvede and Zhang proved in [8] the following *dichotomy* theorem.

Theorem 4. [8] Let $C(W)$ be the Shannon capacity of the channel W and let $C_S(W, V)$ be the secrecy capacity of the wiretap channel (W, V) , then the secure identification capacity of (W, V) is computed as follows:

$$C_{SID}(W, V) = \begin{cases} C(W) & \text{if } C_S(W, V) > 0 \\ 0 & \text{if } C_S(W, V) = 0. \end{cases}$$

C. Channel Model

We consider the following standard model of GWC model.

$$\begin{aligned} W_g: y_i &= x_i + \xi_i, \quad \forall i \in \{1, \dots, n\}, \\ V_{g'}: z_i &= x_i + \phi_i, \quad \forall i \in \{1, \dots, n\}, \end{aligned} \quad (21)$$

where $x^n = (x_1, x_2, \dots, x_n)$ is the channel input sequence. $y^n = (y_1, y_2, \dots, y_n)$ and $z^n = (z_1, z_2, \dots, z_n)$ are Bob and Eve's observations, respectively. $\xi^n = (\xi_1, \xi_2, \dots, \xi_n)$ and $\phi^n = (\phi_1, \phi_2, \dots, \phi_n)$ are the noise sequences of the main channel and the wiretapper's channel, respectively. ξ_i are i.i.d and drawn from a normal distribution denoted by g with zero-mean and variance σ^2 . ϕ_i are i.i.d and drawn from a normal distribution denoted by g' with zero-mean and variance σ'^2 . The channel input fulfills the power constraint defined in (6). The input set is $\mathcal{X}_{n,P}$, defined in (7). The output sets

are infinite $\mathcal{Y} = \mathcal{Z} = \mathbb{R}$. We denote the GWC by the pair $(W_g, V_{g'})$, where W_g and $V_{g'}$ define the Gaussian channels to the legitimate receiver and the wiretapper, respectively.

Definition 11. A randomized (n, M, λ) transmission code for the GWC $(W_g, V_{g'})$ is a family of pairs $\{(Q(\cdot|i), \mathcal{D}_i), i = 1, \dots, M\}$ with

$$Q(\cdot|i) \in \mathcal{P}(\mathcal{X}_{n,P}), \quad \mathcal{D}_i \subset \mathcal{Y}^n, \quad \forall i \in \{1, \dots, M\}$$

such that for all $i \in \{1, \dots, M\}$ and $i \neq j$

$$\int_{x^n \in \mathcal{X}_{n,P}} Q(x^n|i) W_g^n(\mathcal{D}_i^c|x^n) d^n x^n \leq \lambda, \quad (22)$$

$$\mathcal{D}_i \cap \mathcal{D}_j = \emptyset, \quad (23)$$

$$I(U, Z^n) \leq \lambda \quad \lambda \in (0, 1), \quad (24)$$

where U is a uniformly distributed random variable (RV) on $\{1, \dots, M\}$ and Z^n is the output of the channel $V_{g'}$, i.e., the wiretapper's observation. $U - \circlearrowleft X^n - \circlearrowleft Y^n Z^n$ forms a Markov chain.

The strong secrecy capacity of the GWC is denoted by $C_S(g, g', P)$. We mean with $C_S(g, g', P)$ the Shannon capacity of the GWC when strong secrecy requirement (12) is fulfilled.

Based on the definitions of identification codes for the discrete wiretap channel in [8], we introduce identification codes for the GWC.

Definition 12. A randomized $(n, N, \lambda_1, \lambda_2)$ identification code for the GWC $(W_g, V_{g'})$ is a family of pairs $\{(Q(\cdot|i), \mathcal{D}_i), i = 1, \dots, N\}$ with

$$Q(\cdot|i) \in \mathcal{P}(\mathcal{X}_{n,P}), \quad \mathcal{D}_i \subset \mathcal{Y}^n, \quad \forall i \in \{1, \dots, N\}$$

such that for all $i, j \in \{1, \dots, N\}, i \neq j$ and some $\mathcal{E} \subset \mathcal{Z}^n$

$$\int_{x^n \in \mathcal{X}_{n,P}} Q(x^n|i) W_g^n(\mathcal{D}_i^c|x^n) d^n x^n \leq \lambda_1, \quad (25)$$

$$\int_{x^n \in \mathcal{X}_{n,P}} Q(x^n|j) W_g^n(\mathcal{D}_i|x^n) d^n x^n \leq \lambda_2, \quad (26)$$

$$\begin{aligned} & \int_{x^n \in \mathcal{X}_{n,P}} Q(x^n|j) V_{g'}^n(\mathcal{E}|x^n) d^n x^n \\ & + \int_{x^n \in \mathcal{X}_{n,P}} Q(x^n|i) V_{g'}^n(\mathcal{E}^c|x^n) d^n x^n \geq 1 - \lambda, \quad (27) \end{aligned}$$

where $\lambda \in (0, 1)$. We denote with $N_S(n, \lambda, g, g')$ the maximum number such that an $(n, N, \lambda_1, \lambda_2)$ identification wiretap code for the channel $(W_g, V_{g'})$ exists.

- The secure identification rate R of a Gaussian wiretap channel $(W_g, V_{g'})$ is said to be achievable if for all $\lambda \in (0, 1)$ there exists a $n(\lambda)$, such that for all $n \geq n(\lambda)$ there exists an (n, N, λ, λ) wiretap identification code. In this case, $\lambda_1 = \lambda_2 = \lambda$.
- The secure identification capacity $C_{SID}(g, g', P)$ of a Gaussian wiretap channel $(W_g, V_{g'})$ is the supremum of all achievable rates.

In Section V, we investigate correlation-assisted identification. We mean that, additionally to the local randomness at the encoder, we provide the sender and the receiver with an

extra common randomness resource. This is depicted in Fig. 4. We then investigate the effect of the Common Randomness (CR) resource on the identification capacity. We then define in the following the new set-up.

Definition 13. A discrete memoryless multiple source DMMS $P_{XY} \in \mathcal{P}(X \times Y)$ with two components is given, with generic variables X and Y on alphabets \mathcal{X} and \mathcal{Y} , correspondingly. The n -lengths source outputs are observable at Terminals A and B , respectively. Terminal A generates a random variable K with alphabet $|\mathcal{K}|$ and a random sequence T^n as a function of X^n , i.e., $(K, T^n) = \Phi(X^n)$. T^n is sent over a Gaussian channel with input constraint. Let Z^n be the channel output. Terminal B generates the random variable L as a function of Y^n and Z^n , i.e. $L = \Psi(Y^n, Z^n)$. Here, Φ and Ψ refer to functions/signal processing algorithms. This is depicted in Fig. 5. A pair of random variables (K, L) is permissible if K and L are functions of the resources available at Terminal A and Terminal B , respectively i.e.,

$$K = \Phi(X^n) \quad L = \Psi(Y^n, Z^n). \quad (28)$$

Definition 14. A number H is called an achievable CR rate if for sufficiently large n , for some constant c not depending on n , and every $\epsilon > 0 \delta > 0$, there exists a permissible pair of random variables (K, L) such that [23]:

$$\Pr[K \neq L] \leq \epsilon \quad (29)$$

$$|\mathcal{K}| \leq e^{cn} \quad (30)$$

$$\frac{1}{n} H(K) > H - \delta. \quad (31)$$

Definition 15. The CR capacity is the maximum achievable CR rate [23].

Definition 16. A correlation-assisted $(n, N, \lambda_1, \lambda_2)$ identification code for the Gaussian channel W_g is a family of pairs $\{(Q(\cdot|i, x^n), \mathcal{D}_i(y^n), i = 1, \dots, N)\}$ with

$$Q(\cdot|i, x^n) \in \mathcal{P}(\mathcal{T}_{n,P}), \quad \mathcal{D}_i(y^n) \subset \mathcal{Z}^n, \quad \forall i \in \{1, \dots, N\}$$

such that for all $i, j \in \{1, \dots, N\}$, $i \neq j$ and $\lambda_1 + \lambda_2 < 1$, the errors of the first and second kind satisfy:

$$\int_{t^n \in \mathcal{T}_{n,P}} Q(t^n|i, x^n) W_g^n((\mathcal{D}_i(y^n))^c | t^n) d^n t^n \leq \lambda_1, \quad (32)$$

$$\int_{t^n \in \mathcal{T}_{n,P}} Q(t^n|j, x^n) W_g^n(\mathcal{D}_i(y^n) | t^n) d^n t^n \leq \lambda_2 \quad \forall i \neq j. \quad (33)$$

Definition 17. The correlation-assisted identification capacity $C_{ID}^c(g, P)$ of the Gaussian channel W_g is defined as follows:

$$C_{ID}^c(g, P) = \max \left\{ R: \forall \lambda > 0, \exists n(\lambda) \text{ s.t. for } n \geq n(\lambda) N(n, \lambda) \geq e^{nR} \right\} \quad (34)$$

where $N(n, \lambda)$ is the maximum number s.t. a $(n, N, \lambda_1, \lambda_2)$ correlation-assisted identification code for the Gaussian channel W_g exists.

III. IDENTIFICATION FOR GAUSSIAN WIRETAP CHANNELS

In this section, we present and prove the main result of this paper. We first provide identification codes for the GWC and determine the corresponding secure identification capacity.

Theorem 5. Let $C_{SID}(g, g', P)$ be the secure identification capacity of the wiretap channel (W, V, g, g', P) and $C(g, P)$ the identification capacity of the main Gaussian $W(g, P)$ then:

$$C_{SID}(g, g', P) = \begin{cases} C(g, P) & \text{if } C_S(g, g', P) > 0 \\ 0 & \text{if } C_S(g, g', P) = 0. \end{cases}$$

As we mentioned, until now, it is not known whether secure identification can be reached for continuous channels. Here, we completely solve this problem for the GWC by proving Theorem 5. This theorem states that if the secrecy capacity of the GWC is positive, then the corresponding secure identification capacity coincides with the Shannon capacity of the main channel, i.e., the channel from the legitimate sender to the legitimate receiver. Thus, in this case, the channel to the wiretapper has no further influence on the secure identification capacity. For discrete wiretap channels, the alphabet of the wiretapper is discrete, i.e, the wiretapper is far more limited compared to the continuous case. It is advantageous for the wiretapper to deal with infinite alphabet because he has no limit on the hardware resolution. This means that the received signal can be resolved with infinite accuracy. We assume that the eavesdropper has unlimited computational ability and no restrictions regarding quantization and digital hardware platform.

A. Identification Codes for the GWC

B. Optimal Secure Coding Scheme for Identification

The idea of the direct proof is to concatenate two fundamental codes. We consider a transmission code \mathcal{C}' and a wiretap code \mathcal{C}'' as depicted in Fig. 6. For the message set $\{1, \dots, M'\}$ one uses $\{1, \dots, M''\}$ as a suitable indexed set of colorings of the messages with a smaller number of colors. Both of the coloring and color sets are known to the sender and the receiver(s). Every coloring function, denoted by $T_i: \mathcal{C}' \rightarrow \mathcal{C}''$, corresponds to an identification message i . The sender chooses a coloring number j randomly from the set $\{1, \dots, M'\}$ and calculates the color of the identification message i under coloring number j using T_i , denoted by $T_i(j)$. we send both of j with the code \mathcal{C}' and $T_i(j)$ with the code \mathcal{C}'' over the GWC. The receiver, interested in the identification message i , calculates the color of j under T_i and checks whether it is equal to the received color or not. In the first case, he decides that the identification message is i , otherwise he says it was not i . For notational simplicity, we set $\lceil \sqrt{n} \rceil = q$. The resulting $(m, N, \lambda_1, \lambda_2)$ identification code $\mathcal{C} = \{(Q(\cdot|i), \mathcal{D}_i), Q(\cdot|i) \in \mathcal{P}(\mathcal{X}_{m,P}), \mathcal{D}_i \subset \mathcal{Y}^m, i \in \{1, \dots, N\}\}$ has blocklength $m = n + q$. The input set $\mathcal{X}_{m,P}$ is defined analogously to (7),

$$\mathcal{X}_{m,P} = \left\{ x^m \in \mathcal{X}^m \subset \mathbb{R}^m: \sum_{i=1}^m x_i^2 \leq m \cdot P \right\}.$$

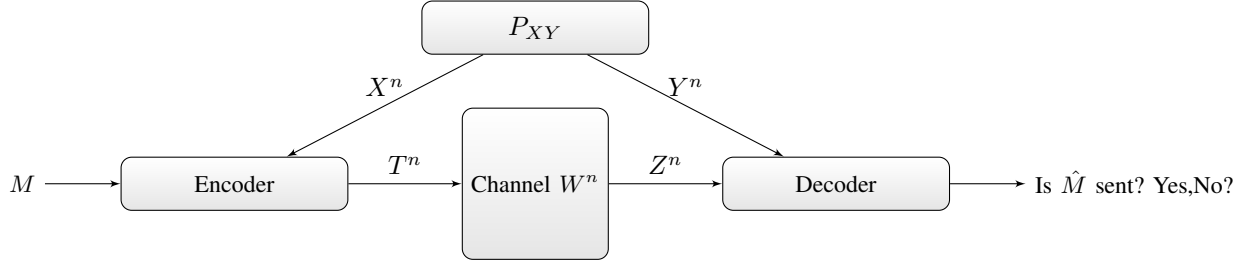

Fig. 4: Correlation-assisted identification

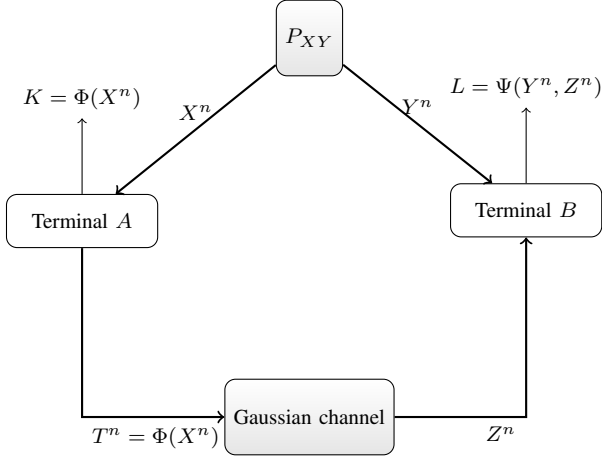

Fig. 5: Two-correlated source model with communication over a Gaussian channel

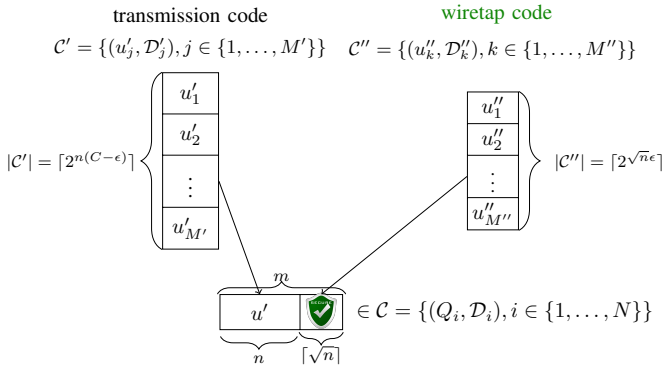

Fig. 6: The construction of the identification wiretap code

For all $i \in \{1, \dots, N\}$, we choose $Q(\cdot|i)$ to be uniformly distributed on the corresponding encoding sets $\mathcal{U}_i \subset \mathcal{X}_{m,P}$.

$$Q(x^m|i) = \begin{cases} \frac{1}{M'}, & \text{if } x^m \in \mathcal{U}_i \\ 0, & \text{otherwise} \end{cases} \quad (35)$$

For more details, we refer the reader to [18].

Remark 2. We showed here the existence of an identification code $(m, N, \lambda_1, \lambda_2)$ with the desired parameters. An explicit construction of identification codes has been studied in [17], [24].

Now we want to show:

$$C_{SID}(\mathbf{g}, \mathbf{g}', P) \geq C(\mathbf{g}, P) \quad \text{if } C_S(\mathbf{g}, \mathbf{g}', P) > 0. \quad (36)$$

As a wiretap code for $(W_{\mathbf{g}}, V_{\mathbf{g}'})$ is also a transmission code, the bounds for the errors of the first kind and of the second kind can be computed similarly to the Gaussian case (see [18]). It is obvious that the concatenated code fulfills the power constraint. Now, it remains to show that (20) holds. For this purpose, it is sufficient to prove that the wiretapper cannot identify the color. We recall some of the results of [8] for discrete memoryless wiretap channels. These results can be also extended for the Gaussian case. If $Q(\cdot|i)$ is an input distribution then the generated output distribution over the channel $V_{\mathbf{g}'}$ denoted by $Q_i V_{\mathbf{g}'}^q(\mathcal{E})$, where the number of channel uses is $q = \lceil \sqrt{n} \rceil$, is defined as the following:

$$Q_i V_{\mathbf{g}'}^q(\mathcal{E}) \triangleq \sum_{x^q \in \mathcal{X}^q} Q(x^q|i) V_{\mathbf{g}'}^q(\mathcal{E}|x^q). \quad (37)$$

We use a stochastic encoder. For any region $\mathcal{E} \subset \mathcal{Z}^q$ and any $i \neq j$, the total variation distance between two output distributions $Q_i V_{\mathbf{g}'}^q(\mathcal{E})$ and $Q_j V_{\mathbf{g}'}^q(\mathcal{E})$ is upper-bounded. Indeed, as shown in [8], from the transmission wiretap code we can construct a transmission code satisfying the following inequality:

$$|Q_i V_{\mathbf{g}'}^q(\mathcal{E}) - Q_j V_{\mathbf{g}'}^q(\mathcal{E})| \leq \epsilon. \quad (38)$$

In case of the GWC, we define $Q_i V_{\mathbf{g}'}^q(\mathcal{E})$ as follows:

$$Q_i V_{\mathbf{g}'}^q(\mathcal{E}) \triangleq \int_{x^q \in \mathcal{X}^q} Q(x^q|i) V_{\mathbf{g}'}^q(\mathcal{E}|x^q) d^q x^q. \quad (39)$$

In spirit of Burnashev's approximation [25], we approximate the GWC $(W_{\mathbf{g}}, V_{\mathbf{g}'})$ by the discrete channel $(\tilde{W}_{\mathbf{g}}, \tilde{V}_{\mathbf{g}'})$. $\mathcal{L}_x \subset \mathcal{X}$ is the new discrete input set and $\mathcal{L}_y \subset \mathcal{Y}$ and $\mathcal{L}_z \subset \mathcal{Z}$ are the new discrete output sets for the legitimate receiver and the wiretapper, respectively. For more details about the sets \mathcal{L}_x , \mathcal{L}_y and \mathcal{L}_z , we refer the reader to the supplementary material. The channels $W_{\mathbf{g}}$ and $V_{\mathbf{g}'}$ are correspondingly approximated by the discrete channels $\tilde{W}_{\mathbf{g}}$ and $\tilde{V}_{\mathbf{g}'}$, respectively. A detailed description of the quantization of the GWC is presented in the supplementary material. If $Q_i V_{\mathbf{g}'}^q(\cdot)$ is an output distribution of the channel $V_{\mathbf{g}'}$, we denote its approximation on $\tilde{V}_{\mathbf{g}'}$ by $\tilde{Q}_i \tilde{V}_{\mathbf{g}'}^q(\cdot)$. It was shown in [25] that:

$$d(Q_i V_{\mathbf{g}'}^q(\cdot), \tilde{Q}_i \tilde{V}_{\mathbf{g}'}^q(\cdot)) \leq \delta, \quad \delta > 0. \quad (40)$$

We now use the stochastic encoder described in [6] for the new quantized GWC $(\tilde{W}_{\mathbf{g}}, \tilde{V}_{\mathbf{g}'})$. We obtain for any region $\mathcal{E} \in \mathcal{Z}^q$:

$$|\tilde{Q}_i \tilde{V}_{\mathbf{g}'}^q(\mathcal{E}) - \tilde{Q}_j \tilde{V}_{\mathbf{g}'}^q(\mathcal{E})| \leq \epsilon. \quad (41)$$

It follows from (40) and (41) that:

$$|Q_i V_{g'}^m(\mathcal{E}) - Q_j \tilde{V}_{g'}^m(\mathcal{E})| \leq \epsilon + 2\delta. \quad (42)$$

We choose δ small enough such that $\epsilon + 2\delta = \epsilon_1$ is very small. It is clear that (42) implies the last secrecy requirement of an identification code for the GWC $(W_g, V_{g'})$. This completes the direct proof. \square

C. Characterization of Optimal Rate

We need the following lemmas to prove the main results of the converse part.

Lemma 1. Let $Q_{z,i}$ and $Q_{z,j}$ be two distributions on \mathcal{Z}^m and for any Lebesgue measurable $\mathcal{E} \subset \mathcal{Z}^m$,

$$Q_{z,i}(\mathcal{E}) + Q_{z,j}(\mathcal{E}^c) > 1 - \epsilon, \quad 0 < \epsilon < \frac{2}{x} \quad (43)$$

and let U be a binary RV with uniform distribution on $\{i, j\}$ and $V^m(z^m|U = i) = Q_{z,i}$, $V^m(z^m|U = j) = Q_{z,j}$ then

$$I(U, Z^m) \leq \inf_{x \in (0, \frac{2}{\epsilon})} \frac{2}{x} + \log \frac{1}{1 - \frac{1}{2}x\epsilon}. \quad (44)$$

$V^m(z^m|U = i)$ and $V^m(z^m|U = j)$ denote the probabilities that Eve observes the output z^m given that the identities i and j have been sent, respectively.

Lemma 2. Let $Q_{y,i}$ and $Q_{y,j}$ be two distributions on \mathcal{Y}^m for which there exists a Lebesgue measurable set $\mathcal{D} \subset \mathcal{Y}^m$ such that

$$Q_{y,i}(\mathcal{D}) + Q_{y,j}(\mathcal{D}^c) < \epsilon, \quad (45)$$

and let U be a binary RV with uniform distribution and $W^m(y^m|U = i) = Q_{y,i}$, $W^m(y^m|U = j) = Q_{y,j}$ then

$$I(U, Y^m) \geq H_2\left(\frac{1}{2}(1 - \epsilon)\right). \quad (46)$$

$W^m(y^m|U = i)$ and $W^m(y^m|U = j)$ denote the probabilities that Bob observes the output y^m given that the identities i and j have been sent, respectively.

Lemmas 1 and 2 were proved for DMCs in [8]. The results can be extended for Gaussian channels.

To prove the converse part, we have to show the following two statements.

$$\begin{cases} C_{SID}(g, g', P) \leq C(g, P) & \text{if } C_S(g, g', P) > 0, \\ C_{SID}(g, g', P) = 0 & \text{if } C_S(g, g', P) = 0. \end{cases} \quad (47)$$

It is obvious that the secure identification capacity cannot exceed the identification capacity of the channel, i.e.,

$$C_{SID}(g, g', P) \leq C_{ID}(g, P) = C(g, P). \quad (48)$$

It remains to show that

$$C_S(g, g', P) = 0 \implies C_{SID}(g, g', P) = 0. \quad (49)$$

For convenience we rather show the following equivalent statement

$$(C_{SID}(g, g', P) > 0) \implies (C_S(g, g', P) > 0). \quad (50)$$

We assume that the secure identification capacity is positive. This implies the existence of a wiretap identification code (m, N, λ, λ) with positive rate for $(W_g, V_{g'})$ (see Definition 12). For convenience, we chose $\lambda_1 = \lambda_2 = \lambda$ for $\lambda < \frac{1}{2}$.

From (25) and (26), we obtain

$$\begin{aligned} & \int_{x^m \in \mathcal{X}_{m,P}} Q(x^m|i) W_g^m(\mathcal{D}_i^c|x^m) d^m x^m \\ & + \int_{x^m \in \mathcal{X}_{m,P}} Q(x^m|j) W_g^m(\mathcal{D}_i|x^m) d^m x^m \leq 2\lambda. \end{aligned} \quad (51)$$

Let U be a binary RV with uniform distribution on the set $\{i, j\}$. We denote the probability $W_g^m(y^m|U = i)$ by $Q_{y,i}$ and $W_g^m(y^m|U = j)$ by $Q_{y,j}$, i.e., (51) can be rewritten as the following:

$$Q_{y,i}(\mathcal{D}^c) + Q_{y,j}(\mathcal{D}) \leq 2\lambda. \quad (52)$$

We now compute $I(U, Y^m)$ as follows:

$$\begin{aligned} I(U, Y^m) &= \sum_{u \in \{i, j\}} \int_{y^m \in \mathcal{Y}^m} P_{UY^m}(u, y^m) \log \frac{P_{UY^m}(u, y^m)}{P_U(u) \cdot P_{Y^m}(y^m)} d^m y^m \\ &= \sum_{u \in \{i, j\}} \int_{y^m \in \mathcal{Y}^m} W_g^m(y^m|u) P_U(u) \log \frac{W_g^m(y^m|u)}{P_{Y^m}(y^m)} d^m y^m \end{aligned} \quad (53)$$

$$\stackrel{(a)}{=} \frac{1}{2} \int_{y^m \in \mathcal{Y}^m} W_g^m(y^m|i) \log \frac{W_g^m(y^m|i)}{\frac{1}{2}(W_g^m(y^m|i) + W_g^m(y^m|j))} d^m y^m \quad (54)$$

$$+ W_g^m(y^m|j) \log \frac{W_g^m(y^m|j)}{\frac{1}{2}(W_g^m(y^m|i) + W_g^m(y^m|j))} d^m y^m \quad (55)$$

$$\stackrel{(b)}{=} \int_{y^m \in \mathcal{Y}^m} \frac{1}{2} Q_{i,y}(y^m) \log \frac{2Q_{i,y}(y^m)}{(Q_{i,y}(y^m) + Q_{j,y}(y^m))} d^m y^m \quad (56)$$

$$+ \int_{y^m \in \mathcal{Y}^m} \frac{1}{2} Q_{j,y}(y^m) \log \frac{2Q_{j,y}(y^m)}{(Q_{i,y}(y^m) + Q_{j,y}(y^m))} d^m y^m.$$

(a) follows by the law of total probability. (b) follows by the definition of $Q_{i,y}$.

We want to establish a lower bound for $I(U, Y^m)$. First, let \tilde{Y} on $\mathcal{L}_y \subset \mathcal{Y}$ be the quantized version of Y . That means, if $\pi(x^n) \in \mathcal{P}(\mathcal{X}_{n,P})$ is an input distribution generating the output distributions $Q_{i,y}(\cdot)$ and $\tilde{Q}_{i,y}(\cdot)$ on the channels W_g and \tilde{W}_g , respectively we have then

$$d(Q_{y,i}(\cdot), \tilde{Q}_{y,i}(\cdot)) \leq \delta', \quad \delta' > 0. \quad (57)$$

From (57) and (52), we obtain

$$\tilde{Q}_{y,i}(\mathcal{D}^c) + \tilde{Q}_{y,j}(\mathcal{D}) \leq 2\lambda + 2\delta', \quad \delta' > 0. \quad (58)$$

We then compute $I(U, \tilde{Y}^m)$ as follows:

$$\begin{aligned} I(U, \tilde{Y}^m) &= \sum_{y^m \in \mathcal{L}_y^m} \frac{1}{2} \tilde{Q}_{i,y}(y^m) \log \frac{2\tilde{Q}_{i,y}(y^m)}{(\tilde{Q}_{i,y}(y^m) + \tilde{Q}_{j,y}(y^m))} \\ &+ \sum_{y^m \in \mathcal{L}_y^m} \frac{1}{2} \tilde{Q}_{j,y}(y^m) \log \frac{2\tilde{Q}_{j,y}(y^m)}{(\tilde{Q}_{i,y}(y^m) + \tilde{Q}_{j,y}(y^m))}. \end{aligned} \quad (59)$$

By applying Lemma 2 on $\tilde{Q}_{y,i}(\mathcal{D}^c)$ and $\tilde{Q}_{y,j}(\mathcal{D})$, we obtain as showed in [8]

$$I(U, \tilde{Y}^m) \geq H_2\left(\frac{1}{2}(1 - 2\lambda - 2\delta')\right). \quad (60)$$

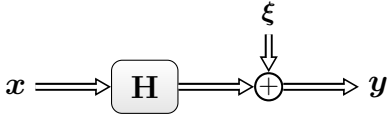

Fig. 7: The Gaussian single-user MIMO channel

Therefore, it follows by data processing inequality

$$I(U, Y^m) \geq I(U, \tilde{Y}^m) \geq H_2\left(\frac{1}{2}(1 - 2\lambda - 2\delta')\right). \quad (61)$$

For the same RV U , we define $Q_{z,i}$ as the probability $V_{g'}^m(z^m|U=i)$ and $Q_{z,j}$ as the probability $V_{g'}^m(z^m|U=j)$. Then, in terms of $Q_{z,j}$ and $Q_{z,i}$, the last condition (20) of the identification wiretap code can be rewritten as follows.

$$Q_{z,j}(\mathcal{E}) + Q_{z,i}(\mathcal{E}^c) \geq 1 - \lambda, \quad i \neq j, \quad \forall \mathcal{E} \subset Z^m. \quad (62)$$

Lemma 1 implies that

$$I(U, Z^m) \leq \inf_{x>0} \left(\frac{2}{x} + \log \frac{1}{1 - \frac{1}{2}x\lambda} \right). \quad (63)$$

For λ and δ small enough, it follows from (61) and (63) that there exists an index n_0 and a RV U with $U \rightarrow X^{n_0} \rightarrow Y^{n_0} Z^{n_0}$ such that

$$I(U, Y^{n_0}) > I(U, Z^{n_0}). \quad (64)$$

That means that we have a code with positive secrecy rate i.e.,

$$C_{SID}(g, g', P) > 0 \implies C_S(g, g', P) > 0.$$

We recall that $C_S(W_g, V_{g'}) = \max_{U \rightarrow X \rightarrow YZ} I(U, Y) - I(U, Z)$. This completes the converse part. \square

IV. IDENTIFICATION FOR THE GAUSSIAN MIMO CHANNEL

In a point-to-point or single-user MIMO communication system, the transmitted signal is a joint transformation of data signals from multiple transmit antennas. The entries of the output signal, collected by multiple receive antennas, are jointly processed. Single-user MIMO communication systems, compared to Single-Input Single-Output (SISO) systems, offer higher rates, more reliability and resistance to interference. In this section, we focus on identification over the Gaussian single-user MIMO channel and compute the corresponding identification capacity.

A. Channel Model

The channel model is depicted in Fig. 7. We consider the following channel model with N_T transmit antennas and N_R receive antennas:

$$\mathbf{y}_i = \mathbf{H}\mathbf{x}_i + \xi_i, \quad \forall i = 1, \dots, n, \quad (65)$$

where n , as previously mentioned, is the number of channel uses. For simplicity, we drop the index i . The input vector $\mathbf{x} \in \mathbb{C}^{N_T}$ contains the N_T scalar transmitted signals and fulfills the following power constraint:

$$\mathbb{E}[\mathbf{x}^H \mathbf{x}] \leq P. \quad (66)$$

The output vector $\mathbf{y} \in \mathbb{C}^{N_R}$ comprises the scalar received signals of the N_R channel outputs. The channel matrix

$$\mathbf{H} = \begin{pmatrix} h_{11} & \dots & h_{1N_T} \\ \vdots & \ddots & \vdots \\ h_{N_R1} & \dots & h_{N_R N_T} \end{pmatrix} \in \mathbb{C}^{N_R \times N_T}$$

is a full-rank matrix. The entry h_{ij} represents the channel gain from transmit antenna j to receive antenna i . The vector $\xi \in \mathbb{C}^{N_R}$ is circularly symmetric Gaussian noise, $\xi \sim \mathcal{N}_{\mathbb{C}}(\mathbf{0}_{N_R}, \sigma^2 \mathbf{I}_{N_R})$. If \mathbf{H} is deterministic and perfectly known at the transmitter and the receiver, then the capacity $C(P, N_T \times N_R)$ of the MIMO channel described in (65) is given by [26]:

$$C(P, N_T \times N_R) = \max_{\mathbf{Q}: \text{tr}(\mathbf{Q})=P} \log \det(\mathbf{I}_{N_R} + \frac{1}{\sigma^2} \mathbf{H}\mathbf{Q}\mathbf{H}^H).$$

where $\mathbf{Q} \in \mathbb{C}^{N_T \times N_T}$ is the covariance matrix of the input vector \mathbf{x} .

B. Capacity via Singular Value Decomposition

The capacity $C(P, N_T \times N_R)$ can be computed by converting the MIMO channel into parallel, independent and scalar Gaussian sub-channels. This conversion is based on the following singular value decomposition (SVD) of the channel matrix \mathbf{H} :

$$\mathbf{H} = \mathbf{U}\mathbf{\Lambda}\mathbf{V}^H, \quad (67)$$

where $\mathbf{U} \in \mathbb{C}^{N_R \times N_R}$ and $\mathbf{V} \in \mathbb{C}^{N_T \times N_T}$ are unitary matrices. $\mathbf{\Lambda} \in \mathbb{C}^{N_R \times N_T}$ is a diagonal matrix, whose diagonal elements $\lambda_1 \geq \lambda_2 \geq \dots \geq \lambda_N$ are the ordered singular values of the channel matrix \mathbf{H} . We denote with N the rank of \mathbf{H} , $N := \min(N_T, N_R)$. If we multiply (65) with the unitary matrix \mathbf{U}^H , we obtain then:

$$\underbrace{\mathbf{U}^H \mathbf{y}}_{:= \tilde{\mathbf{y}}} = \mathbf{U}^H \mathbf{U} \mathbf{\Lambda} \underbrace{\mathbf{V}^H \mathbf{x}}_{:= \tilde{\mathbf{x}}} + \underbrace{\mathbf{U}^H \xi}_{:= \tilde{\xi}}. \quad (68)$$

It can easily be checked that $\tilde{\xi}$ has the same distribution as ξ , i.e., $\tilde{\xi} \sim \mathcal{N}_{\mathbb{C}}(\mathbf{0}_{N_T}, \sigma^2 \mathbf{I}_{N_R})$ and we have:

$$\mathbb{E}[\tilde{\mathbf{x}}^H \tilde{\mathbf{x}}] = \mathbb{E}[\mathbf{x}^H \mathbf{V} \mathbf{V}^H \mathbf{x}] = \mathbb{E}[\mathbf{x}^H \mathbf{x}].$$

Thus, we obtain the N independent scalar Gaussian channels depicted in Fig. 8.

$$\tilde{y}_l = \lambda_l \tilde{x}_l + \tilde{\xi}_l, \quad l = 1, \dots, N. \quad (69)$$

The SVD can be interpreted as a pre-processing (multiplication with \mathbf{V}) and a post-processing (multiplication with \mathbf{U}^H). The optimization problem in (IV-A) is reduced to [26], [27]

$$C(P, N_T \times N_R) = \max_{\tilde{P}_1, \dots, \tilde{P}_N} \sum_{l=1}^N \log \left(1 + \frac{\lambda_l^2}{\sigma^2} \tilde{P}_l \right), \quad (70)$$

$$\text{s.t. } \sum_{l=1}^N \tilde{P}_l \leq P \quad \text{and} \quad \tilde{P}_l \geq 0, \quad l = 1, \dots, N.$$

The power \tilde{P}_l is determined as follows [26].

$$\tilde{P}_l = \max(0, \mu - \frac{\sigma^2}{\lambda_l^2}), \quad l = 1, \dots, N. \quad (71)$$

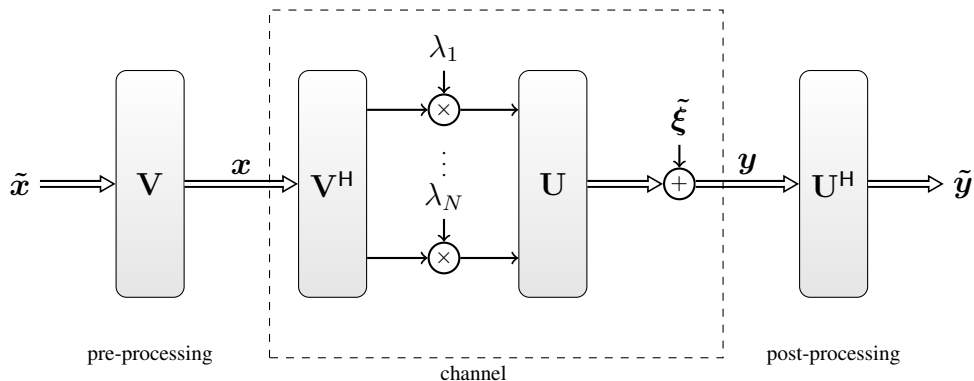

Fig. 8: Decomposition of the MIMO channel into N parallel channels through SVD

The expression above to compute \tilde{P}_l is called the *waterfilling* rule and μ is the *waterfilling level*. Each of the λ_l corresponds to an eigenmode of the channel, also called eigenchannel.

If the channel gain $\frac{\lambda_l^2}{\sigma^2}$ is large enough, power \tilde{P}_l is given to the respective eigenmode. Otherwise, we allocate no power to the eigenchannel.

C. Lower Bound on Identification Capacity

We denote with $C(\mathbf{g}, \tilde{P}_l)$ and $C_{ID}(\mathbf{g}, \tilde{P}_l)$ the Shannon capacity and the identification capacity of each Gaussian sub-channel l , respectively. We assume that we decompose the channel in (65) as described above in Fig. 8. We have a serial-to-parallel conversion, where we convert each signal vector \mathbf{x} into N parallel scalar signals \tilde{x}_l , $1 \leq l \leq N$. Each signal vector lies in a cartesian product of input sets. We perform transmit beamforming by multiplying each signal vector \mathbf{x} with the matrix \mathbf{V}^H . \tilde{x}_l results from multiplying \mathbf{x} with the l -th column of \mathbf{V} . We choose each power \tilde{P}_l by waterfilling to maximize the capacity $C(P, N_T \times N_R)$. Since we may lose information via processing, we have:

$$C_{ID}(P, N_T \times N_R) \geq \sum_{l=1}^N C_{ID}(\mathbf{g}, \tilde{P}_l) \quad (72)$$

where $C_{ID}(P, N_T \times N_R)$ denotes the identification capacity of the MIMO Gaussian channel in (65). Furthermore, we know from Theorem. 2 that for each sub-channel l the following equation holds.

$$C(\mathbf{g}, \tilde{P}_l) = C_{ID}(\mathbf{g}, \tilde{P}_l) \quad (73)$$

From (72) and (73) we deduce that

$$\begin{aligned} C_{ID}(P, N_T \times N_R) &\geq \sum_{l=1}^N C(\mathbf{g}, \tilde{P}_l) \\ &= C(P, N_T \times N_R) \end{aligned} \quad (74)$$

This shows that for the single-user MIMO case, we obtain the following proposition:

Proposition 1.

$$C_{ID}(P, N_T \times N_R) \geq C(P, N_T \times N_R). \quad (75)$$

V. CORRELATION-ASSISTED IDENTIFICATION

In this section, we consider an identification scheme with a common randomness resource as depicted in Fig. 4. In contrast to transmission, it appears that the common randomness resource can increase the identification capacity. We derive a lower bound on the correlation-assisted identification capacity within this setting.

Proposition 2. Let $C_{ID}(\mathbf{g}, P)$ and $C(\mathbf{g}, P)$ be the identification capacity and the Shannon capacity of the Gaussian channel in model in Fig 4. It holds:

$$C_{ID}^c(\mathbf{g}, P) \geq C(\mathbf{g}, P) + I(X, Y)$$

Proof. Assume now that Alice and Bob have common randomness capacity $C_{CR}(\mathbf{g}, P)$. Then, by applying the Transformator-Lemma [28] [29], it holds that

$$C_{ID}^c(\mathbf{g}, P) \geq C_{CR}(\mathbf{g}, P) \quad \text{if } C_{ID}(\mathbf{g}, P) > 0. \quad (76)$$

In addition, the common randomness capacity for the model depicted in Fig. 5 has been computed in [30] for the case where no randomization is permitted.

$$C_{CR}(P) = \max_{\substack{U \\ U \circlearrowleft X \circlearrowleft Y \\ I(U; X) - I(U; Y) \leq C(\mathbf{g}, P)}} I(U; X). \quad (77)$$

This could be easily extended for the case where terminal A is allowed to randomize. The maximum achievable common randomness rate without randomization is $H(X)$ for $C(\mathbf{g}, P) \geq H(X|Y)$. This can be checked by setting $U = X$ in (77). Now the terminal A has access to local randomness and the capacity of the channel $C(\mathbf{g}, P)$ is greater than $H(X|Y)$. We can split the channel capacity as follows:

$$C(\mathbf{g}, P) = H(X|Y) + R_2, \quad R_2 > 0, \quad R_1 = H(X|Y) \quad (78)$$

We need the rate $H(X|Y)$ to achieve with help of common randomness the rate $R_1 = H(X) = H(X|Y) + I(X, Y)$ and the rate R_2 is used to transmit local randomness. $R_1 + R_2$ is achieved by time-sharing. Hence,

$$C_{CR}(\mathbf{g}, P) = C(\mathbf{g}, P) + I(X, Y), \quad \text{if } C(\mathbf{g}, P) \geq H(X|Y). \quad (79)$$

This completes the proof. \square

Remark 3. As showed in [23], it is suboptimal for the common randomness generation to transmit $nC(g, P)$ random bits disregarding the DMMS P_{XY} . Infact, for the case where $C(g, P) > H(X|Y)$, the common randomness capacity $C_{CR}(g, P)$ exceeds $C(g, P)$ with exactly $I(X, Y)$.

Remark 4. It worth noting that we are using a randomized identification code as described in Definition. 3, which represents a local randomness. Additionally, the sender and the receiver have access to a common randomness resource P_{XY} .

Remark 5. Correlation cannot increase the Shannon message-transmission capacity. However, this is not the case for identification, where we can achieve a performance gain by taking advantage of the common randomness resource. This makes the identification scheme more interesting in the current communication systems.

Remark 6. We further emphasize that (76) holds when the identification capacity of the channel is positive. It has been proved that the common randomness capacity of a channel can exceed its identification capacity. For instance, we consider a "trash" channel, i.e, with zero transmission capacity. The sender and the receiver have access to common randomness resource. This means that the common randomness capacity in this case is positive. However, the corresponding identification capacity is zero since we cannot transmit over the channel. [28].

Example 1. Consider the example of binary sources such that $|\mathcal{X}| = |\mathcal{Y}| = 2$ with $P_X(0) = P_X(1) = \frac{1}{2}$. We consider the following transition probability

$$P_{Y|X}(y|0) = \begin{pmatrix} 1 - \mu \\ \mu \end{pmatrix} \quad 0 \leq \mu \leq \frac{1}{2} \quad (80)$$

$$P_{Y|X}(y|1) = \begin{pmatrix} \mu \\ 1 - \mu \end{pmatrix} \quad 0 \leq \mu \leq \frac{1}{2} \quad (81)$$

with

$$P_{XY}(x, y) = P_{Y|X}(y|x)P_X(x) \quad (x, y) \in \{0, 1\}^2. \quad (82)$$

In this case, it holds that:

$$\begin{aligned} P_Y(y) &= \sum_{x \in \{0, 1\}} P_{XY}(x, y) \\ &= \frac{1}{2} \sum_{x \in \{0, 1\}} P_{Y|X}(y|x) \end{aligned} \quad (83)$$

and

$$\begin{aligned} I(X; Y) &= \sum_{x \in \{0, 1\}} \sum_{y \in \{0, 1\}} P_{XY}(x, y) \log \left(\frac{P_{XY}(x, y)}{P_X(x)P_Y(y)} \right) \\ &= \frac{1}{2} \sum_{x \in \{0, 1\}} \sum_{y \in \{0, 1\}} P_{Y|X}(y|x) \log \left(\frac{2P_{Y|X}(y|x)}{P_{Y|X}(y|0) + P_{Y|X}(y|1)} \right) \\ &= \frac{1}{2} \sum_{x \in \{0, 1\}} \sum_{y \in \{0, 1\}} P_{Y|X}(y|x) \log (2P_{Y|X}(y|x)) \end{aligned} \quad (84)$$

It has been proved in [10] that the identification capacity of

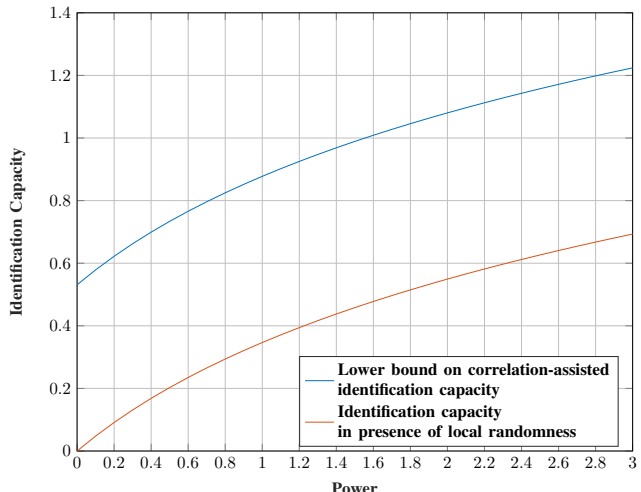

Fig. 9: Comparison of the lower bound on correlation-assisted identification capacity to the identification capacity in presence of local randomness for a noise variance $\sigma^2 = 1$, for the correlated sources presented in Example 1 with $\mu = 0.1$

the Gaussian channel in presence of local randomness is equal to the Shannon capacity of the channel. Clearly, the proposed lower bound exceeds $C(g, P)$. For instance, for $\mu = 0.1$ and for a noise variance $\sigma^2 = 1$, we can achieve a performance gain of at least 0.531, as depicted in Fig. 9.

VI. CONCLUSIONS

We have examined identification over Gaussian channels for their practical relevance. We have extended the direct proof of the identification coding theorem to the Gaussian case. We recall that the transition from the discrete case to the Gaussian case is not obvious. Burnashev has shown that for the white Gaussian channel without bandwidth constraint and finite Shannon capacity, the corresponding identification capacity is infinite. The main focus of the paper was to calculate the secure identification capacity for the GWC. Secure identification for discrete alphabets has been extensively studied over the recent decades due to its important potential use in many future scenarios. For discrete channels, it was proved that secure identification is robust under channel uncertainty and against jamming attacks. However, for continuous alphabets, no results have yet been established. This problem seems to be difficult because the wiretapper, in contrast to the discrete case, is not limited anymore and has infinite alphabet. This is advantageous for the wiretapper since he has no limit on the hardware resolution. This means that the received signal can be resolved with infinite accuracy. In this paper, we completely solved the Gaussian case for its practical relevance. In particular, we have provided a coding scheme for secure identification over the GWC and have determined the corresponding capacity. In Theorem 5 says that secure identification is possible for continuous channels, particularly for the Gaussian case. We also studied identification over single-user MIMO channel, which are of major interest for wireless communications. We

derived a lower bound on the corresponding capacity. As a direct continuation of this work, it would be interesting to investigate identification for continuous-time channels. Future research might also explore secure identification over MIMO channels.

APPENDIX A

QUANTIZATION OF A DISCRETE-TIME CHANNEL WITH ADDITIVE NOISE AND INFINITE INPUT AND OUTPUT ALPHABETS

Burnashev considered in [25] the approximation of output measures for channels with infinite alphabets. In this section, we give a summary of the quantization scheme, which we modified and applied on the GWC.

A. Channel Model

The following additive noise channel is considered.

$$y_i = x_i + \xi_i, \quad \forall i \in \{1, \dots, n\}. \quad (85)$$

$x^n = (x_1, x_2, \dots, x_n)$ is the channel input sequence and y^n is the output sequence. ξ_i are iid for all $i \in \{1, \dots, n\}$ and drawn from a noise function f satisfying the regularity conditions described in [10]. The channel input fulfills the following peak power constraint:

$$|x_i| \leq a, \quad a > 0, \quad \forall i = 1, \dots, n. \quad (86)$$

It follows from (86) that the new constrained input set is $\mathcal{X} = [-a, a]$. The output set is infinite $\mathcal{Y} = \mathbb{R}$. We denote that channel by W_f with Shannon capacity $C(f, a)$.

B. Quantization Steps

The channel W_f should be approximated by a discrete channel with input and output alphabets \mathcal{L}_x and \mathcal{L}_y , respectively. \mathcal{L}_x and \mathcal{L}_y should fulfill the following inequalities:

$$\lim_{n \rightarrow \infty} \frac{|\mathcal{L}_x|}{n} \ln n = 0, \quad (87)$$

$$\lim_{n \rightarrow \infty} \frac{|\mathcal{L}_y|}{n} \ln^4 n = 0. \quad (88)$$

- 1) $\mathcal{X} = [-a, a]$ is quantized by choosing in it a lattice \mathcal{L}_x with span δ_x . Any input vector $u^n \in \mathcal{X}^n$ is approximated by $u'^n \in \mathcal{L}_x^n$. u'_i is chosen to be the closest to u_i in terms of euclidean distance with $|u'_i| \leq |u_i|$. Let $Q_{u^n} W_f^n(\cdot)$ and $Q_{u'^n} W_f^n(\cdot)$ be the output distributions generated by $u^n \in \mathcal{X}^n$ and $u'^n \in \mathcal{L}_x^n$ over W_f , respectively.

$$Q_{u'^n} W_f^n(y^n) = W_f^n(y^n | u'^n), \quad y^n \in \mathcal{Y}^n. \quad (89)$$

$Q_{u'^n} W_f^n(\cdot)$ is defined correspondingly. We have

$$\begin{aligned} d(Q_{u^n} W_f^n(\cdot), Q_{u'^n} W_f^n(\cdot)) &\leq 2 \left(K \sum_{i=1}^n |u_i - u'_i|^\gamma \right)^{\frac{1}{2}} \\ &\leq 2\sqrt{Kn\delta_x^\gamma}. \end{aligned} \quad (90)$$

We set $\delta_x = \left(\frac{\delta^2}{nK}\right)^{\frac{1}{\gamma}}$. The cardinality of \mathcal{L}_x is denoted by L_x and is upper-bounded as follows:

$$L_x \leq \frac{2a}{\delta_x} + 2. \quad (91)$$

The original channel W_f is then approximated by the channel W_{f, \mathcal{L}_x} with finite input alphabet \mathcal{L}_x . Generally, let $\pi(x^n)$ be any prior distribution on \mathcal{X}^n generating $Q_\pi^n W_f^n(\cdot)$ on \mathcal{Y}^n . $\pi'(x^n)$, $x^n \in \mathcal{L}_x^n$ is chosen such that the generated output distribution $Q_{\pi'}^n W_{f, \mathcal{L}_x}^n(\cdot)$ satisfies the following inequality:

$$d(Q_\pi^n W_f^n(\cdot), Q_{\pi'}^n W_{f, \mathcal{L}_x}^n(\cdot)) \leq 2\delta, \quad \delta > 0. \quad (92)$$

For all $y^n \in \mathcal{Y}^n$,

$$Q_\pi^n W_{f, \mathcal{L}_x}^n(y^n) = \int_{x^n \in \mathcal{L}_x^n} \pi(x^n) W_{f, \mathcal{L}_x}^n(y^n | x^n) dx^n. \quad (93)$$

- 2) Now, the output set \mathcal{Y} should be bounded. For this purpose, the following quantization function is defined.

$$l: \mathbb{R} \rightarrow [-z_0, z_0], \quad (94)$$

$$l(y) = \begin{cases} y & y \in [-z_0, z_0], \\ z_0 & \text{else,} \end{cases} \quad (95)$$

where $z_0 = a + b$, $b > 0$. The probability that an output vector y^n is not in $[-z_0, z_0]^n$ can be computed as follows.

$$\Pr\{y^n \notin [-z_0, z_0]^n\} \stackrel{(a)}{\leq} \sum_{i=1}^n \Pr\{y_i \notin [-z_0, z_0]\} \quad (96)$$

$$\stackrel{(b)}{=} \sum_{i=1}^n \int_{|\xi_i| \geq z_0 - x_i} f(\xi_i) d\xi_i \quad (97)$$

$$\stackrel{(c)}{\leq} \sum_{i=1}^n K_1 (z_0 - x_i)^{-\alpha} \quad (98)$$

$$\stackrel{(d)}{\leq} K_1 n b^{-\alpha}. \quad (99)$$

(a) follows by the union bound. (b) follows because $y_i = x_i + \xi_i$. (c) follows by (107). (d) follows because $x_i \leq a$, $\forall i = 1, \dots, n$.

If we choose $b = \left(\frac{K_1 n}{\delta}\right)^{\frac{1}{\alpha}}$, we have then

$$\Pr\{y^n \notin [-z_0, z_0]^n\} \leq \delta, \quad \delta > 0. \quad (100)$$

Thus, the channel W_{f, \mathcal{L}_x} is approximated by another channel $W_{f, \mathcal{L}_x, z_0}$ with bounded output alphabet. Let $\pi'(x^n)$, $x^n \in \mathcal{L}_x^n$ be any prior distribution generating $Q_{\pi'}^n W_{f, \mathcal{L}_x}^n(\cdot)$ and $Q_{\pi'}^n W_{f, \mathcal{L}_x, z_0}^n(\cdot)$ on W_{f, \mathcal{L}_x} and $W_{f, \mathcal{L}_x, z_0}$, respectively. We have then:

$$d(Q_{\pi'}^n W_{f, \mathcal{L}_x}^n(\cdot), Q_{\pi'}^n W_{f, \mathcal{L}_x, z_0}^n(\cdot)) \leq 2\delta. \quad (101)$$

- 3) Now $[-z_0, z_0]$ should be approximated by a finite set.

$$[-z_0, z_0] = \cup_{i=-i_0}^{i_0} [i\epsilon, (i+1)\epsilon) + \{z_0\}, \quad i_0 = \frac{z_0}{\epsilon}, \quad \epsilon > 0.$$

$[-z_0, z_0]$ is quantized by choosing in it the lattice \mathcal{L}_y .

$$\mathcal{L}_y = \{y: y = i\epsilon, \quad i = -i_0, \dots, i_0\}, \quad i_0 = \frac{z_0}{\epsilon}.$$

Next, the noise function f is approximated by a piecewise constant density f_ϵ defined as follows:

$$f_\epsilon(y-x) = \begin{cases} \frac{1}{\epsilon} \int_{i\epsilon}^{(i+1)\epsilon} f(t-x) dt, & y \in \mathcal{D}_\epsilon \\ f(z_0-x) + \int_{|\xi|>z_0} f(\xi-x) d\xi, & y = z_0, \end{cases} \quad (102)$$

where $\mathcal{D}_\epsilon = [i\epsilon, (i+1)\epsilon)$. The new discrete channel is denoted by \tilde{W}_f , which has finite input and output alphabets \mathcal{L}_x and \mathcal{L}_y , respectively. If $\pi'(x^n)$, $x^n \in \mathcal{L}_x^n$ is any prior distribution generating $Q_{\pi'}^n W_{f, \mathcal{L}_x, z_0}^n(\cdot)$ and $Q^n \tilde{W}_f^n(\cdot)$ on $W_{f, \mathcal{L}_x, z_0}$ and \tilde{W}_f , respectively, then for $\delta > 0$:

$$d\left(Q_{\pi'}^n W_{f, \mathcal{L}_x, z_0}^n(\cdot), Q^n \tilde{W}_f^n(\cdot)\right) \leq 2\delta. \quad (103)$$

Combining (92), (101) and (103), we deduce the following lemma [25].

Lemma. [25] *If $\pi(x^n)$ any prior distribution on \mathcal{X}^n generating $Q_\pi^n W_f^n(\cdot)$ on \mathcal{Y}^n , then we choose some prior distribution $\pi'(x^n)$, $x^n \in \mathcal{L}_x^n$ generating over the channel \tilde{W}_f an output distribution $Q^n \tilde{W}_f^n(\cdot)$ such that the following inequality holds:*

$$d\left(Q_\pi^n W_f^n(\cdot), Q^n \tilde{W}_f^n(\cdot)\right) \leq 6\delta, \quad \delta > 0. \quad (104)$$

Remark 7. Burnashev extended this quantization to additive noise channels with average power constraint, i.e., the input $x^n = (x_1, x_2, \dots, x_n)$ satisfies the following inequality:

$$\frac{1}{n} \sum_{i=1}^n x_i^2 \leq P. \quad (105)$$

Thus, the same quantization scheme can be also applied on Gaussian channels with average power constraint. For a more detailed description, we refer the reader to [25].

APPENDIX B

QUANTIZATION OF THE GAUSSIAN WIRETAP CHANNEL

We consider the same GWC $(W_g, V_{g'})$ described in (5), where each input signal x_i lies in the set $[-\sqrt{nP}, \sqrt{nP}]$ for all $i \in \{1, \dots, n\}$. The output sets are \mathcal{Y} and \mathcal{Z} , which lie in the set of real numbers. We modify the scheme in [25] to be applicable on the GWC. Note that g and g' , as normal distributions, satisfy the regularity conditions cited in [10]. This means, there exist some constants K, K_1, γ, α such that: For $u > 0$ and $1 < \gamma \leq 2$

$$\int_{-\infty}^{\infty} \left(\max_{|t-x| \leq u} \sqrt{g(t)} - \min_{|t-x| \leq u} \sqrt{g(t)} \right)^2 dx \leq Ku^\gamma, \quad (106)$$

For $z > 0$ and $\alpha > 2$

$$\int_{|x| \geq z} g(x) dx \leq K_1 z^{-\alpha}, \quad (107)$$

$$1/\alpha + 1/\gamma < 1. \quad (108)$$

This holds also for g' , i.e., there exist some constants $K', K'_1, \gamma', \alpha'$ such that the aforementioned regularity condi-

tions are fulfilled. It can easily be checked that we can choose constants as follows:

$$\begin{aligned} K &= \frac{1}{\sigma^2}, \quad K' = \frac{1}{\sigma'^2}, \\ K_1 &= K'_1 = 1, \\ \gamma &= \gamma' = 2, \\ \alpha &= \alpha' = 3. \end{aligned}$$

For more details, we refer the reader to [18]. The quantization of $(W_g, V_{g'})$ consists of the two following steps.

A. Quantization of the Input Set $[-\sqrt{nP}, \sqrt{nP}]$

First, we quantize $[-\sqrt{nP}, \sqrt{nP}]$ by choosing in it the lattice \mathcal{L}_x with span $\delta_x > 0$. We mean with span δ_x the maximum L_1 distance between two points in the one-dimensional lattice \mathcal{L}_x . We approximate any input vector $x^n = (x_1, x_2, \dots, x_n) \in \mathcal{X}_{n,P} \subseteq [-\sqrt{nP}, \sqrt{nP}]$ as defined in (6) by $\hat{x}^n = (\hat{x}_1, \hat{x}_2, \dots, \hat{x}_n) \in \mathcal{L}_x^n$ such that \hat{x}_i is the closest to x_i in terms of euclidean distance with $|\hat{x}_i| \leq |x_i|$. We denote the output distributions generated by the input vector x^n over W_g and $V_{g'}$ by $Q_{x^n} W_g^n(\cdot)$ and $Q_{x^n} V_{g'}^n(\cdot)$ respectively. Analogously, $Q_{\hat{x}^n} W_g^n(\cdot)$ and $Q_{\hat{x}^n} V_{g'}^n(\cdot)$ are the generated output distributions by the input \hat{x}^n over W_g and $V_{g'}$, respectively. It follows from (36) in [25] that for $\delta > 0$:

$$d(Q_{x^n} W_g^n(\cdot), Q_{\hat{x}^n} W_g^n(\cdot)) \leq 2\sqrt{Kn\delta_x} \leq 2\delta, \quad (109)$$

$$d(Q_{x^n} V_{g'}^n(\cdot), Q_{\hat{x}^n} V_{g'}^n(\cdot)) \leq 2\sqrt{K'n\delta_x} \leq 2\delta. \quad (110)$$

We define K_{max} as follows:

$$K_{max} = \max(K, K'). \quad (111)$$

We set $\delta_x = \left(\frac{\delta^2}{nK_{max}}\right)^{\frac{1}{\gamma}}$ and denote the cardinality of \mathcal{L}_x by L_x . We have:

$$L_x \leq \frac{2a}{\delta_x} + 2 = 2a(K_{max}n\delta^2)^{\frac{1}{\gamma}} + 2. \quad (112)$$

We denote the new quantized channels with discrete input alphabet \mathcal{L}_x by W_{g, \mathcal{L}_x} and V_{g', \mathcal{L}_x} . Let $\pi(x^n)$ be any probability distribution on $\mathcal{X}_{n,P}$ generating the output distributions $Q_\pi^n W_g^n(\cdot)$ on \mathcal{Y}^n and $Q_\pi^n V_{g'}^n(\cdot)$ on \mathcal{Z}^n . From (109) and (110), we deduce that we can find some input distribution $\hat{\pi}(x^n) \in \mathcal{P}(\mathcal{L}_x^n)$ generating output distributions $Q_{\hat{\pi}}^n W_{g, \mathcal{L}_x}^n(\cdot)$ and $Q_{\hat{\pi}}^n V_{g', \mathcal{L}_x}^n(\cdot)$ over W_{g, \mathcal{L}_x} and V_{g', \mathcal{L}_x} , respectively such that for $\delta > 0$

$$d(Q_\pi^n W_g^n(\cdot), Q_{\hat{\pi}}^n W_{g, \mathcal{L}_x}^n(\cdot)) \leq 2\delta, \quad (113)$$

$$d(Q_\pi^n V_{g'}^n(\cdot), Q_{\hat{\pi}}^n V_{g', \mathcal{L}_x}^n(\cdot)) \leq 2\delta. \quad (114)$$

The new noise functions defined on $[-z_0, z_0]$ are denoted by g_{z_0} and g'_{z_0} .

B. Quantization of \mathcal{Y} and \mathcal{Z}

We first consider the output set \mathcal{Y} . We proceed as described in [25]. First, we choose $z_0 = a + \left(\frac{K_1 n}{\delta}\right)^{\frac{1}{\alpha}}$. We assign z_0 to all outputs y with $|y| > z_0$ and denote the new channel with discrete input set \mathcal{L}_x and bounded output set $[-z_0, z_0]$ by $W_{g, \mathcal{L}_x, z_0}$. Thus, if $\hat{\pi}(x^n) \in \mathcal{P}(\mathcal{L}_x^n)$ generates the output

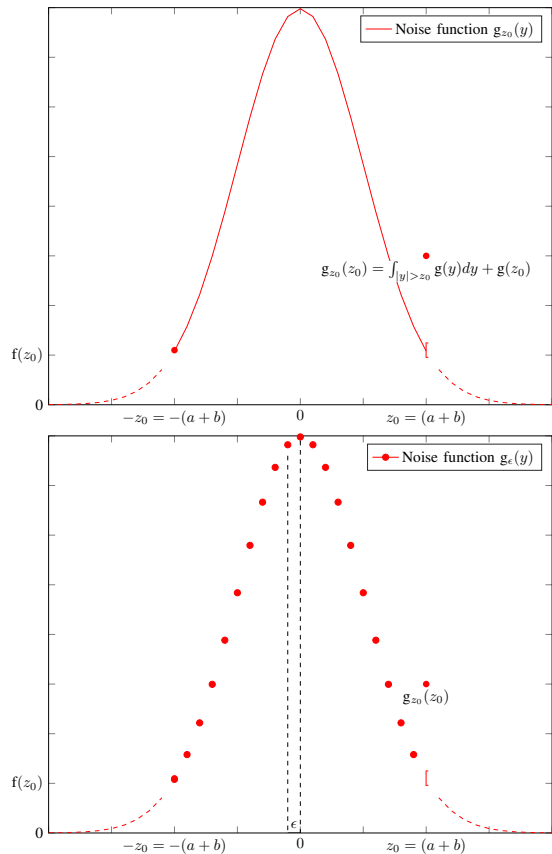

Fig. 10: Example of the quantization steps of the noise function g .

distributions $Q_{\hat{\pi}}^n W_{g, \mathcal{L}_x}^n(\cdot)$ and $Q_{\hat{\pi}}^n W_{g, \mathcal{L}_x, z_0}^n(\cdot)$ over W_{g, \mathcal{L}_x} and $W_{g, \mathcal{L}_x, z_0}$, respectively, then for $\delta > 0$

$$d\left(Q_{\hat{\pi}}^n W_{g, \mathcal{L}_x}^n(\cdot), Q_{\hat{\pi}}^n W_{g, \mathcal{L}_x, z_0}^n(\cdot)\right) \leq 2\delta. \quad (115)$$

Now, we choose in $[-z_0, z_0]$ the lattice \mathcal{L}_y with span ϵ , where

$$\epsilon = \left(\frac{\delta^2}{K_{max} n}\right)^{\frac{1}{\gamma}}, \quad \delta > 0. \quad (116)$$

We correspondingly approximate g_{z_0} by a piece-wise constant noise function g_{ϵ} , depicted in Fig. 10. We denote the cardinality of \mathcal{L}_y by L_y . We have:

$$L_y \leq \frac{2z_0}{\epsilon} + 4 = 2 \left(\frac{Kn}{\delta^2}\right)^{\frac{1}{\gamma}} \left(a + \left(\frac{nK_1}{\delta}\right)^{\frac{1}{\alpha}}\right) + 4. \quad (117)$$

We denote the new channel with discrete input alphabet \mathcal{L}_x and discrete output alphabet \mathcal{L}_y by \tilde{W}_g . If $\hat{\pi}(x^n) \in \mathcal{P}(\mathcal{L}_x^n)$ generates the output distributions $Q_{\hat{\pi}}^n W_{g, \mathcal{L}_x, z_0}^n(\cdot)$ and $Q_{\hat{\pi}}^n \tilde{W}_g^n(\cdot)$ over $W_{g, \mathcal{L}_x, z_0}$ and \tilde{W}_g , respectively, then for $\delta > 0$

$$d\left(Q_{\hat{\pi}}^n W_{g, \mathcal{L}_x, z_0}^n(\cdot), Q_{\hat{\pi}}^n \tilde{W}_g^n(\cdot)\right) \leq 2\delta. \quad (118)$$

From (113), (115) and (118), we deduce that if $\pi(x^n)$ is a probability distribution on $\mathcal{X}_{n, P}$ generating the output distributions $Q_{\pi}^n W_g^n(\cdot)$ over W_g , we can find some input distribution

$\hat{\pi}(x^n)$, $\hat{\pi}(x^n) \in \mathcal{P}(\mathcal{L}_x^n)$ generating the output distribution $Q_{\hat{\pi}}^n \tilde{W}_g^n(\cdot)$ over \tilde{W}_g such that for $\delta > 0$

$$d\left(Q_{\pi}^n W_g^n(\cdot), Q_{\hat{\pi}}^n \tilde{W}_g^n(\cdot)\right) \leq 6\delta, \quad \delta > 0. \quad (119)$$

The quantization of \mathcal{Z} follows the same scheme because $\mathcal{Y} = \mathcal{Z} = \mathbb{R}$ and the quantization of \mathcal{Y} and \mathcal{Z} depends on K_{max} and the constants K_1, α, γ . These constants are the same for both noise functions g and g' . We have then:

$$d\left(Q_{x^n} V_{g'}^n(\cdot), Q_{\hat{\pi}}^n \tilde{V}_{g'}^n(\cdot)\right) \leq 6\delta, \quad \delta > 0, \quad (120)$$

where \mathcal{L}_z is the new discrete output set of Eve's channel and $\tilde{V}_{g'}$ denotes the new discrete Eve's channel. $Q_{x^n} V_{g'}^n(\cdot)$ is the output distribution generated by the input Q_{x^n} over $V_{g'}$ and $Q_{\hat{\pi}}^n \tilde{V}_{g'}^n(\cdot)$ is the output distribution generated by the input $Q_{\hat{\pi}}^n$ over $\tilde{V}_{g'}$.

Remark 8. If the wiretap channel has a positive secrecy capacity $C(g, g', P)$, $K_{max} = \max(\frac{1}{\sigma^2}, \frac{1}{\sigma'^2}) = \frac{1}{\sigma^2} = K$.

ACKNOWLEDGMENTS

Holger Boche was supported by the Deutsche Forschungsgemeinschaft (DFG, German Research Foundation) under Germany's Excellence Strategy - EXC 2092 CASA - 390781972. Christian Deppe and Wafa Labidi were supported by the Bundesministerium für Bildung und Forschung (BMBF) through Grants 16KIS1005 and 16KIS1003K.

REFERENCES

- [1] W. Labidi, C. Deppe, and H. Boche, "Secure identification for gaussian channels," in *ICASSP 2020 - 2020 IEEE International Conference on Acoustics, Speech and Signal Processing (ICASSP)*, 2020, pp. 2872–2876.
- [2] C. E. Shannon, "A mathematical theory of communication," *Bell System Technical Journal*, vol. 27, pp. 379–423, 623–656, July, October 1948.
- [3] R. Ahlswede and G. Dueck, "Identification via channels," *IEEE Transactions on Information Theory*, vol. 35, no. 1, pp. 15–29, Jan 1989.
- [4] —, "Identification in the presence of feedback—a discovery of new capacity formulas," *IEEE Transactions on Information Theory*, vol. 35, no. 1, pp. 30–36, Jan 1989.
- [5] H. Boche, R. F. Schaefer, and H. Vincent Poor, "On the computability of the secret key capacity under rate constraints," in *ICASSP 2019 - 2019 IEEE International Conference on Acoustics, Speech and Signal Processing (ICASSP)*, May 2019, pp. 2427–2431.
- [6] H. Boche and C. Deppe, "Secure identification for wiretap channels; robustness, super-additivity and continuity," *IEEE Transactions on Information Forensics and Security*, vol. 13, no. 7, pp. 1641–1655, July 2018.
- [7] G. Fettweis et al., "The tactile internet," in *ITU-T Technol. WatchRep.*, 2014, pp. 1–24.
- [8] R. Ahlswede and Z. Zhang, "New directions in the theory of identification via channels," *IEEE Transactions on Information Theory*, vol. 41, no. 4, pp. 1040–1050, 1995.
- [9] T. S. Han, *Information-Spectrum Methods in Information Theory*, ser. Stochastic Modelling and Applied Probability. Springer-Verlag Berlin Heidelberg, 2014.
- [10] M. V. Burnashev, "On method of "types", approximation of output measures and id-capacity for channels with continuous alphabets," in *Proceedings of the 1999 IEEE Information Theory and Communications Workshop (Cat. No. 99EX253)*, June 1999, pp. 80–81.
- [11] H. Boche and C. Deppe, "Secure identification under passive eavesdroppers and active jamming attacks," *IEEE Transactions on Information Forensics and Security*, vol. 14, pp. 472–485, 2019.
- [12] S. Baur, C. Deppe, and H. Boche, "Secure storage for identification; random resources and privacy leakage," *IEEE Transactions on Information Forensics and Security*, vol. 14, no. 8, pp. 2013–2027, Aug 2019.

- [13] M. Wiese and H. Boche, "Semantic security and the second-largest eigenvalue of biregular graphs," *CoRR*, vol. abs/1811.07798, 2018.
- [14] M. J. Salarisiddigh, U. Pereg, H. Boche, and C. Deppe, "Deterministic identification over fading channels," 2020.
- [15] —, "Deterministic identification over channels with power constraints," 2020.
- [16] T. S. Han and S. Verdú, "New results in the theory of identification via channels," *IEEE Transactions on Information Theory*, vol. 38, no. 1, pp. 14–25, Jan 1992.
- [17] S. Verdú and V. K. Wei, "Explicit construction of optimal constant-weight codes for identification via channels," *IEEE Transactions on Information Theory*, vol. 39, no. 1, pp. 30–36, Jan 1993.
- [18] W. Labidi, "Secure Identification for Gaussian Channels," Master's thesis, Lehrstuhl für Nachrichtentechnik der Technische Universität München, June 2019.
- [19] A. D. Wyner, "The wire-tap channel," *The Bell System Technical Journal*, vol. 54, no. 8, pp. 1355–1387, Oct 1975.
- [20] I. Csiszár and J. Körner, "Broadcast channels with confidential messages," *IEEE Transactions on Information Theory*, vol. 24, no. 3, pp. 339–348, May 1978.
- [21] I. Csiszár and J. Körner, *Information theory: Coding theorems for discrete memoryless systems*. Cambridge University Press, 1 2011.
- [22] I. Bjelaković, H. Boche, and J. Sommerfeld, "Secrecy results for compound wiretap channels," *Probl. Inf. Transm.*, vol. 49, no. 1, pp. 73–98, Jan. 2013.
- [23] R. Ahlswede and I. Csiszár, "Common randomness in information theory and cryptography. ii. cr capacity," *IEEE Transactions on Information Theory*, vol. 44, no. 1, pp. 225–240, 1998.
- [24] S. Derebeyoğlu, C. Deppe, and R. Ferrara, "Performance analysis of identification codes," *Entropy*, no. 22, 2020.
- [25] M. V. Burnashev, "On the method of types and approximation of output measures for channels with finite alphabets," *Problems Inform. Transmission*, vol. 36, no. 3, pp. 195–212, 2000.
- [26] D. Tse and P. Viswanath, *Fundamentals of Wireless Communication*. New York, NY, USA: Cambridge University Press, 2005.
- [27] N. Chiurtu, B. Rimoldi, and E. Telatar, "On the capacity of multi-antenna gaussian channels," in *Proceedings. 2001 IEEE International Symposium on Information Theory (IEEE Cat. No.01CH37252)*, 2001, pp. 53–.
- [28] R. Ahlswede, "General theory of information transfer: Updated," *Discrete Applied Mathematics*, vol. 156, pp. 1348–1388, 05 2008.
- [29] R. Ahlswede and G. Dueck, "Identification in the presence of feedback—a discovery of new capacity formulas," *IEEE Transactions on Information Theory*, vol. 35, no. 1, pp. 30–36, Jan 1989.
- [30] R. Ezzine, W. Labidi, C. Deppe, and H. Boche, "Common randomness generation and identification over gaussian channels," in *GLOBECOM 2020- IEEE Global Communications Conference (GLOBECOM)*, 2020, accepted.