

EFFICIENT END-TO-END SPEECH RECOGNITION USING PERFORMERS IN CONFORMERS

Peidong Wang¹ DeLiang Wang^{1,2}

¹Department of Computer Science and Engineering, The Ohio State University, USA

²Center for Cognitive and Brain Sciences, The Ohio State University, USA

{wang.7642, wang.77}@osu.edu

ABSTRACT

On-device end-to-end speech recognition poses a high requirement on model efficiency. Most prior works improve the efficiency by reducing model sizes. We propose to reduce the complexity of model architectures in addition to model sizes. More specifically, we reduce the floating-point operations in conformer by replacing the transformer module with a performer. The proposed attention-based efficient end-to-end speech recognition model yields competitive performance on the LibriSpeech corpus with 10 millions of parameters and linear computation complexity. The proposed model also outperforms previous lightweight end-to-end models by about 20% relatively in word error rate.

Index Terms— efficient, end-to-end, performer, conformer

1. INTRODUCTION

End-to-end (E2E) speech recognition models map audio features directly to token level representations, making them easily deployable to mobile devices [1, 2, 3, 4, 5, 6, 7, 8, 9]. On-device speech recognition could protect users' privacy since the audio recordings do not need to be sent to the server. Compared with a server based model, on-device systems have a higher requirement on the efficiency of automatic speech recognition (ASR) algorithms since the computational resources and battery life are typically limited in this case.

Many recent works showed that E2E speech recognition models with reduced model sizes can perform comparably to their larger counterparts. Krivanek *et al.* proposed QuartzNet [10], which is a convolutional neural network (CNN) based model achieving competitive results on the LibriSpeech corpus with only 19 millions (19M) of parameters. The ContextNet proposed by Han *et al.* improves QuartzNet by replacing the connectionist temporal classification (CTC) decoder with the recurrent neural network transducer (RNN-T) decoder, and exploiting global context information with a squeeze-and-excitation module [11]. ContextNet reaches the performance of previous best speech recognition models using as few as 10.8M of parameters. The conformer proposed

by Gulati *et al.* [12] combines CNN and transformer in a macaron style structure and achieved a slightly better performance than ContextNet with a simpler model architecture.

Transformer is a popular architecture in E2E speech recognition models because of its ability to model the global context information in an utterance [13, 14]. Due to the correlation calculation, the complexity of transformer is quadratic to the length of the feature. In [13], Yeh *et al.* used truncated self-attention to reduce the complexity at the cost of tangible performance degradation. Wu *et al.* improved the transformer module with augmented memory (AM-TRF) [15]. The efficient memory transformer proposed by Shi *et al.* [16] further improved the AM-TRF model and achieved significant speed and performance boost. Fujita *et al.* [17] proposed to replace the self-attention operation with dynamic convolution. Recently, Xu *et al.* [18] used local dense synthesizer attention in a conformer architecture. The model shows competitive results on the AISHELL-1 Mandarin speech corpus.

In order for E2E models to be deployed on mobile devices, we need to not only reduce the model sizes but also improve the efficiency of transformer models without significant performance loss. We first reduce the model size of an attention based E2E ASR model using conformer [19] to 10M. After that, we adopt the performer [20] method for efficiency improvement. The performer method uses orthogonal positive random features for fast attention calculation and achieves competitive results on various tasks. In this study, we replace the transformer in conformer with performer. Experimental results on attention based E2E models show that the proposed performer in conformer (PIC) model obtains competitive results on LibriSpeech with linear computation complexity and a small model size [21]. We also outperforms the dynamic and lightweight convolution approach [17] by about 20% relatively in WER with a substantially smaller model size.

The remainder of this paper is organized as follows. We describe the PIC approach in Section 2. In Section 3 and 4, we present the experimental setup and evaluation results, respectively. Concluding remarks are given in Section 5.

2. SYSTEM DESCRIPTION

2.1. Conformer

A conformer module contains the following operations:

$$\tilde{\mathbf{X}} = \mathbf{X} + \frac{1}{2}\text{FFN}(\mathbf{X}) \quad (1)$$

$$\mathbf{X}' = \tilde{\mathbf{X}} + \text{MHSA}(\tilde{\mathbf{X}}) \quad (2)$$

$$\mathbf{X}'' = \mathbf{X}' + \text{Conv}(\mathbf{X}') \quad (3)$$

$$\mathbf{Y} = \text{Layernorm}(\mathbf{X}'' + \frac{1}{2}\text{FFN}(\mathbf{X}'')) \quad (4)$$

where $\mathbf{X} \in \mathbb{R}^{T \times f}$ is the input to the conformer module and $\mathbf{Y} \in \mathbb{R}^{T \times p}$ is the output. The T , f , and p denote the length of the features, the input feature dimension, and the output feature dimension. Functions FFN, MHSA, Conv, and Layernorm denote feedforward neural network, multi-head self attention, convolutional layer, and layer normalization, respectively.

2.2. Performer in Conformer

The complexity of operations in equation (2) is typically $\mathcal{O}(T^2)$. In PIC, we reduce the complexity to $\mathcal{O}(T)$ by using performer to replace equation (2). Equation (2) can thus be written as:

$$\mathbf{X}' = \tilde{\mathbf{X}} + \text{MHSAP}(\tilde{\mathbf{X}}) \quad (5)$$

where MHSAP refers to the performer based multi-head self attention function.

We denote each performer based attention head in MHSAP as SAP. In SAP, three feedforward networks first embeds the input to a triplet of query, key, and value:

$$\tilde{\mathbf{Q}} = \text{FFN}_q(\tilde{\mathbf{X}}) \quad (6)$$

$$\tilde{\mathbf{K}} = \text{FFN}_k(\tilde{\mathbf{X}}) \quad (7)$$

$$\tilde{\mathbf{V}} = \text{FFN}_v(\tilde{\mathbf{X}}) \quad (8)$$

where $\tilde{\mathbf{Q}} \in \mathbb{R}^{T \times d}$, $\tilde{\mathbf{K}} \in \mathbb{R}^{T \times d}$, $\tilde{\mathbf{V}} \in \mathbb{R}^{T \times d}$ denote query, key, and value. The d is the attention dimension. The three neural networks for query, key, and value are denoted as FFN_q , FFN_k , and FFN_v , respectively.

A conventional transformer calculates the inner product of $\tilde{\mathbf{Q}}$ and $\tilde{\mathbf{K}}$ to get the $T \times T$ correlation matrix. In performer, a mapping from a d -dimensional vector to a positive r -dimensional vector $\phi: \mathbb{R}^d \rightarrow \mathbb{R}_+^r$ is performed on each row of $\tilde{\mathbf{Q}}$ and $\tilde{\mathbf{K}}$:

$$\tilde{\mathbf{q}}_i^p = \phi((\tilde{\mathbf{q}}_i)^T)^T \quad (9)$$

$$\tilde{\mathbf{k}}_j^p = \phi((\tilde{\mathbf{k}}_j)^T)^T \quad (10)$$

where $\tilde{\mathbf{q}}_i$ and $\tilde{\mathbf{k}}_j$ denote row i and j of $\tilde{\mathbf{Q}}$ and $\tilde{\mathbf{K}}$, respectively. The output vectors in the mapped space are $\tilde{\mathbf{q}}_i^p$ and $\tilde{\mathbf{k}}_j^p$. The corresponding matrices are $\tilde{\mathbf{Q}}^p \in \mathbb{R}^{T \times r}$ and $\tilde{\mathbf{K}}^p \in \mathbb{R}^{T \times r}$.

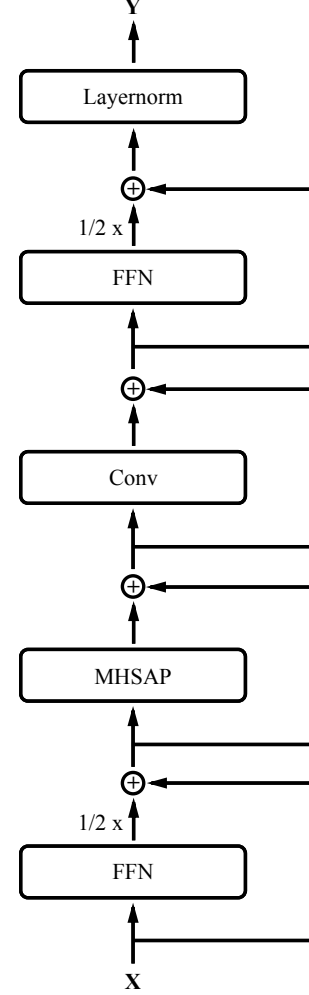

Fig. 1: Diagram of PIC. The PIC architecture is the same as conformer other than that we use MHSAP instead of MHSA to capture the global information. The $1/2 \times$ denotes that the FFN output is scaled by $1/2$ and the \oplus symbol is element-wise addition.

The output of SAP($\tilde{\mathbf{X}}$) can thus be expressed as:

$$\text{SAP}(\tilde{\mathbf{X}}) = (\tilde{\mathbf{D}}^p)^{-1}(\tilde{\mathbf{Q}}^p((\tilde{\mathbf{K}}^p)^T \mathbf{V})) \quad (11)$$

where $\tilde{\mathbf{D}}^p = \text{diag}((\tilde{\mathbf{Q}}^p((\tilde{\mathbf{K}}^p)^T \mathbf{1}_T)))$ is the denominator of the softmax function used in the attention mechanism, $\text{diag}(\cdot)$ is a diagonal function and $\mathbf{1}_T$ is an all-one vector of length T .

Since $(\tilde{\mathbf{K}}^p)^T \in \mathbb{R}^{r \times T}$ is first multiplied with $\mathbf{V} \in \mathbb{R}^{T \times d}$, the computation complexity is reduced. In performer, the mapping function $\phi(\cdot)$ is carefully chosen so that $\phi(\cdot) \geq 0$ and the random features are orthogonal. Since the output of softmax function is also non-negative, performer provides a better way to approximate the conventional transformer.

Applying the performer described above, we get the PIC architecture, as depicted in Fig. 1.

Model	#params	dev-clean	dev-other	test-clean	test-other
conformer	116.4M	2.0	5.2	2.2	5.3
conformer	10.4M	2.4	6.3	2.7	6.5
conformer	4.3M	4.5	9.4	4.7	9.9

Table 1: WER (%) comparisons among conformers of different model sizes on LibriSpeech. The *#params* denotes the number of parameters in the model.

2.3. Operation Counter for Efficient Audio and Speech Networks

The efficiency of most existing E2E speech recognition models is evaluated on either the number of model parameters, an asymptotic notation of computation complexity, or the real time factor (RTF). These metrics all have disadvantages. First, the number of model parameters does not strongly correlate with the actual operations in the model. For example, although transformers only need to store the embedding feed-forward neural networks as parameters, their complexity is quadratic with respect to the length of the input. Second, the asymptotic notation of computation complexity may not capture the multiple factors influencing the model efficiency. For instance, for the same transformer architecture, the number of operations increases with a larger attention dimension. Third, the RTF metric is hardware dependent, making it difficult to compare the models from different research groups.

A better way to evaluate the efficiency of speech recognition models is to count the actual number of operations with a fixed input. To achieve this, we create an operation counter for efficient audio and speech networks (OCEAN) at <https://github.com/Peidong-Wang/OCEAN>.

3. EXPERIMENTAL SETUP

3.1. Data and Model

Our experiments are conducted on the LibriSpeech corpus [22]. The training set contains 960 hours of read English speech. All the training and evaluation pipelines are used the same way as the official recipe.

We use the ESPnet toolkit [23] for our experiments. The baseline uses the conformer provided in the toolkit, which performs slightly worse than the results reported in [19]. To reduce the model size, we change the attention dimension of conformer from 512 to 144, the number of attention heads from 8 to 4, decoder layers from 6 to 5, and encoder hidden units from 2048 to 144. We also slightly increase the number of encoder layers from 12 to 16. These configurations are changed so that the model contains about 10M of parameters. After that, we replace the transformer module in the conformer with performer to further improve the model complexity. Note that we only apply PIC in the encoder of the E2E model.

3.2. Implementation Details

Since performer does not have a correlation matrix, we change the positional encoding method of conformer from relative positional encoding to absolute positional encoding [12, 19]. In addition, we moved the dropout operation of conformer to the final output, which is different from the implementation in ESPnet.

During evaluation, we report the results using the external language model, following the convention of most prior studies using the same toolkit. Note that based on [21], attention based E2E models such as the one used in this study can incorporate language level information effectively using multitask training. Therefore, the reported results may be comparable with prior studies using RNN-T decoding and without the external language model.

4. EVALUATION RESULTS

4.1. Conformers of Different Model Sizes

Table 1 shows the WERs of conformers of different model sizes. Note that this comparison differs from the one in [12] in that the decoder is based on the attention method rather than RNN-T. The conformer with 116.4M parameters is typically referred to as a large model, whereas the one with 10.4M parameters a small model. We further reduce the number of parameters to 4.3M to explore the limit of the model size reduction on the LibriSpeech corpus. The large model is 10x the size of the small model, whereas the absolute WER reduction on test-clean is considerably small (i.e. 0.5%). The results on other evaluation sets changes the same way as test-clean, suggesting that the reduction of parameters hurts the modeling capacity of the model. When we further reduce the model size to 4.3M, the WER degrades to 4.7% on test-clean. This shows that there is a trade-off between model size and modeling capacity. In the remainder of this paper, we use the 10.4M variant of conformer since it yields good performance with a small model size.

4.2. Positional Encoding

Table 2 compares the conformer model with different positional encoding methods. Relative positional encoding for the small-sized conformer outperforms the absolute positional encoding method by 10% on test-clean. The relative

Model	#params	pos	dev-clean	dev-other	test-clean	test-other
conformer	10.4M	relative	2.4	6.3	2.7	6.5
conformer	10.4M	absolute	2.7	6.7	3.0	7.1

Table 2: WER (%) comparisons between conformers with relative and absolute positional encoding methods. The *pos* denotes positional encoding method.

Model	#params	encoder complexity	dev-clean	dev-other	test-clean	test-other
conformer	10.4M	$\mathcal{O}(T^2)$	2.7	6.7	3.0	7.1
SA-DC2D [17]	-	-	3.5	9.6	3.9	9.6
DC [17]	-	-	3.5	10.5	3.6	10.8
PIC	10.4M	$\mathcal{O}(T)$	2.9	7.2	3.1	7.7

Table 3: WER (%) comparisons among attention based efficient end-to-end speech recognition models. The T denotes the input feature length.

difference is 8% on test-other. This shows that positional encoding methods have a tangible impact on this attention based small-sized E2E ASR model, which uses conformers in the encoder. Since PIC uses absolute positional encoding, we use the conformer with absolute positional encoding in the following sections.

4.3. Performers in Conformers

Table 3 compares PIC with conformer and the DC and SA-DC2D models proposed in [17]. The DC model uses dynamic convolution in both encoder and decoder, whereas the SA-DC2D model uses self-attention in encoder and dynamic convolution in decoder. We use DC and SA-DC2D in this comparison since they achieve the best performances on test-clean and test-other sets of LibriSpeech, respectively. Note that the local dense synthesizer attention method in [18] is evaluated on a Mandarin corpus and is thus not directly comparable with conformer, [17], and PIC. Compared with the small-sized conformer model using absolute positional encoding, PIC performs slightly worse. The small performance degradation demonstrates that with a linear computation complexity, performer can approximate the transformer in conformer with a high precision. Since SA-DC2D uses self-attention in encoder, it may still have an encoder complexity of $\mathcal{O}(T^2)$, which is larger than the $\mathcal{O}(T)$ complexity of PIC. On test-clean, PIC outperforms SA-DC2D by 21% relatively. A similar improvement is observed on other evaluation sets. This clearly shows that PIC can reduce the computation complexity of the model without causing tangible performance loss. Note that the SA-DC2D model does not pose a model size limit, whereas PIC is both small in size and efficiency in computation. For DC, the complexity of the encoder is $\mathcal{O}(T)$. Compared with DC, PIC achieves a relative WER improvement of 17% on test-clean. On test-other, the relative im-

provement reaches 29%. This is in line with the comparison with SA-DC2D and shows the effectiveness of PIC on reducing the computation complexity without severely sacrificing the performance. Note that in the above analysis, we do not distinguish between time and space complexity. Transformer, and therefore conformer, is quadratic in both time and space complexity with regard to input length, whereas PIC is linear in both.

5. CONCLUDING REMARKS

We have proposed an efficient E2E speech recognition model using performers in conformers. It improves the efficiency of E2E models by reducing both the model size and the computation complexity of the building block. Evaluated on the LibriSpeech corpus, PIC outperforms previously proposed efficient models by about 20% relatively on average, with a much smaller model size. Future work includes applying PIC to transducer based models, designing streaming and universal versions of PIC based models, combining relative positional encoding with PIC, and improving the evaluation metric of efficient E2E speech recognition models.

6. ACKNOWLEDGEMENTS

We would like to thank Ron J. Weiss and Tara N. Sainath at Google for helpful discussions on the evaluation metrics of efficient end-to-end speech recognition, and Yanzhang He, Jiahui Yu, Yu Zhang, and Wei Han on efficient neural networks. This work was supported in part by two NSF grants (IIS-1409431 and ECCS-1808932) and the Ohio Supercomputer Center.

7. REFERENCES

- [1] Y. He, T. N. Sainath, R. Prabhavalkar, I. McGraw, R. Alvarez, D. Zhao, D. Rybach, A. Kannan, Y. Wu, R. Pang, et al., “Streaming end-to-end speech recognition for mobile devices,” in *IEEE International Conference on Acoustics, Speech and Signal Processing (ICASSP)*. IEEE, 2019, pp. 6381–6385.
- [2] T. N. Sainath, R. Pang, et al., “Two-pass end-to-end speech recognition,” *arXiv preprint arXiv:1908.10992*, 2019.
- [3] P. Wang, J. Cui, C. Weng, and D. Yu, “Token-wise training for attention based end-to-end speech recognition,” in *Acoustics, Speech and Signal Processing (ICASSP), 2019 IEEE International Conference on*. 2019, IEEE.
- [4] P. Wang, J. Cui, C. Weng, and D. Yu, “Large margin training for attention based end-to-end speech recognition,” in *INTERSPEECH*, 2019, pp. 246–250.
- [5] T. N. Sainath, R. Pang, R. J. Weiss, Y. He, C. C. Chiu, and T. Strohmman, “An attention-based joint acoustic and text on-device end-to-end model,” in *Proc. of IEEE International Conference on Acoustics, Speech and Signal Processing (ICASSP)*. IEEE, 2020, pp. 7039–7043.
- [6] P. Wang and D. L. Wang, “Utterance-wise recurrent dropout and iterative speaker adaptation for robust monaural speech recognition,” in *Proc. of International Conference on Acoustics, Speech and Signal Processing (ICASSP)*, 2018, pp. 4814–4818.
- [7] P. Wang and D. L. Wang, “Filter-and-Convolve: A CNN based multichannel complex concatenation acoustic model,” in *Proc. of International Conference on Acoustics, Speech and Signal Processing (ICASSP)*, 2018, pp. 5564–5568.
- [8] Peidong Wang, Ke Tan, and De Liang Wang, “Bridging the Gap Between Monaural Speech Enhancement and Recognition with Distortion-Independent Acoustic Modeling,” in *Proc. of INTERSPEECH*, 2019, pp. 471–475.
- [9] Peidong Wang and De Liang Wang, “Enhanced Spectral Features for Distortion-Independent Acoustic Modeling,” in *Proc. of INTERSPEECH*, 2019, pp. 476–480.
- [10] S. Krivan, S. Beliaev, B. Ginsburg, et al., “Quartznet: Deep automatic speech recognition with 1d time-channel separable convolutions,” in *Proc. of ICASSP*. IEEE, 2020, pp. 6124–6128.
- [11] W. Han, Z. Zhang, Y. Zhang, J. Yu, C. C. Chiu, J. Qin, A. Gulati, R. Pang, and Y. Wu, “Contextnet: Improving convolutional neural networks for automatic speech recognition with global context,” *arXiv preprint arXiv:2005.03191*, 2020.
- [12] A. Gulati, J. Qin, C. C. Chiu, N. Parmar, Y. Zhang, J. Yu, W. Han, S. Wang, Z. Zhang, Y. Wu, et al., “Conformer: Convolution-augmented transformer for speech recognition,” *arXiv preprint arXiv:2005.08100*, 2020.
- [13] C. F. Yeh, J. Mahadeokar, K. Kalgaonkar, et al., “Transformer-transducer: End-to-end speech recognition with self-attention,” *arXiv preprint arXiv:1910.12977*, 2019.
- [14] Q. Zhang, H. Lu, H. Sak, et al., “Transformer transducer: A streamable speech recognition model with transformer encoders and rnn-t loss,” in *Proc. of ICASSP*. IEEE, 2020, pp. 7829–7833.
- [15] C. Wu, Y. Wang, Y. Shi, C. F. Yeh, and F. Zhang, “Streaming transformer-based acoustic models using self-attention with augmented memory,” *arXiv preprint arXiv:2005.08042*, 2020.
- [16] Y. Shi, Y. Wang, C. Wu, C. F. Yeh, et al., “Emformer: Efficient memory transformer based acoustic model for low latency streaming speech recognition,” *arXiv preprint arXiv:2010.10759*, 2020.
- [17] Y. Fujita, A. S. Subramanian, M. Omachi, and S. Watanabe, “Attention-based asr with lightweight and dynamic convolutions,” in *Proc. of ICASSP*. IEEE, 2020, pp. 7034–7038.
- [18] M. Xu, S. Li, and X. L. Zhang, “Transformer-based end-to-end speech recognition with local dense synthesizer attention,” *arXiv preprint arXiv:2010.12155*, 2020.
- [19] P. Guo, F. Boyer, X. Chang, et al., “Recent developments on espnet toolkit boosted by conformer,” *arXiv preprint arXiv:2010.13956*, 2020.
- [20] K. Choromanski, V. Likhoshesterov, D. Dohan, et al., “Rethinking attention with performers,” 2020.
- [21] P. Wang, T. N. Sainath, and R. J. Weiss, “Multitask training with text data for end-to-end speech recognition,” *arXiv preprint arXiv:2010.14318*, 2020.
- [22] V. Panayotov, G. Chen, D. Povey, and S. Khudanpur, “Librispeech: an asr corpus based on public domain audio books,” in *Proc. of ICASSP*. IEEE, 2015, pp. 5206–5210.
- [23] S. Watanabe, T. Hori, S. Karita, et al., “Espnet: End-to-end speech processing toolkit,” *arXiv preprint arXiv:1804.00015*, 2018.