

RECON: Relation Extraction using Knowledge Graph Context in a Graph Neural Network

Anson Bastos
cs20resch11002@iith.ac.in
Indian Institute of Technology,
Hyderabad and Zerotha Research
India

Abhishek Nadgeri
abhishek22596@gmail.com
RWTH Aachen and Zerotha Research,
Germany

Kuldeep Singh
kuldeep.singh1@cerence.com
Cerence GmbH and Zerotha Research
Germany

Isaiah Onando Mulang'
isaiah.mulang.onando@iais.fraunhofer.de
Fraunhofer IAIS and Zerotha
Research, Germany

Saeedeh Shekarpour
sshkarpour1@udayton.edu
University of Dayton, USA

Johannes Hoffart
johannes.hoffart@gs.com
Goldman Sachs, Germany

ABSTRACT

In this paper, we present a novel method named RECON, that automatically identifies relations in a sentence (sentential relation extraction) and aligns to a knowledge graph (KG). RECON uses a graph neural network to learn representations of both the sentence as well as facts stored in a KG, improving the overall extraction quality. These facts, including entity attributes (label, alias, description, instance-of) and factual triples, have not been collectively used in the state of the art methods. We evaluate the effect of various forms of representing the KG context on the performance of RECON. The empirical evaluation on two standard relation extraction datasets shows that RECON significantly outperforms all state of the art methods on NYT Freebase and Wikidata datasets. RECON reports 87.23 F1 score (Vs 82.29 baseline) on Wikidata dataset whereas on NYT Freebase, reported values are 87.5(P@10) and 74.1(P@30) compared to the previous baseline scores of 81.3(P@10) and 63.1(P@30).

ACM Reference Format:

Anson Bastos, Abhishek Nadgeri, Kuldeep Singh, Isaiah Onando Mulang', Saeedeh Shekarpour, and Johannes Hoffart. 2020. RECON: Relation Extraction using Knowledge Graph Context in a Graph Neural Network. In *Woodstock '18: ACM Symposium on Neural Gaze Detection, June 03–05, 2018, Woodstock, NY*. ACM, New York, NY, USA, 11 pages. <https://doi.org/10.1145/nnnnnnn.nnnnnnn>

1 INTRODUCTION

The publicly available Web-scale knowledge graphs (KGs) (e.g., DBpedia [1], Freebase [2], and Wikidata [23]) find wide usage in many real world applications such as question answering, fact checking, voice assistants, and search engines [5]. Despite the success and popularity, these KGs are not exhaustive. Hence there is a need for approaches that automatically extract knowledge from unstructured text into the KGs [12]. Distantly supervised *relation extraction*

(RE) is one of the knowledge graph completion tasks aiming at determining the entailed relation between two given entities annotated on the text to a background KG [26, 29]. For example, given the sentence "Bocelli also took part in the Christmas in Washington special on Dec 12, in the presence of president Barack Obama and the first lady" with annotated entities- *wdt:Q76 (Barack Obama)*¹ and *wdt:Q13133(Michelle Obama)*; the RE task aims to infer the semantic relationship. Here *wdt:P26 (spouse)* is the target relation. In this example, one can immediately see the impact of background knowledge: the correct target relation *spouse* is not explicitly stated in the sentence, but given background knowledge about the first lady and her marital status, the correct relation can be inferred by the model. In cases having no relations, the label "NA" is predicted.

Existing RE approaches have mainly relied on the multi-instance and distant learning paradigms [19]. Given a bag of sentences (or instances), the **multi-instance RE** considers all previous occurrences of a given entity pair while predicting the target relation [21]. However, incorporating contextual signals from the previous occurrences of entity pair in the neural models add some noise in the training data, resulting in a negative impact on the overall performance [14]. Several approaches (e.g., based on attention mechanism [28], neural noise converter [26]) have been proposed to alleviate the noise from the previous sentences for improving overall relation extraction. Additionally, to mitigate the noise in multi-instance setting, there are few approaches that not only use background KGs as a source of target relation but exploit specific properties of KGs as additional contextual features for augmenting the learning model. Earlier work by [10, 21] utilizes entity descriptions and entity/relation aliases from the underlying KG as complementary features. Work in [16] employs attention-based embeddings of KG triples to feed in a graph attention network for capturing the context. Overall, the knowledge captured from KG complements the context derived from the text.

In contrast, the **sentential RE** [20] ignores any other occurrence of the given entity pair, thereby making the target relation predictions on the sentence level. However, the existing approaches for sentential RE [20, 30] rely on local features/context present in the sentence and do not incorporate any external features. In this paper, we study the effect of KG context on sentential RE task by

Permission to make digital or hard copies of part or all of this work for personal or classroom use is granted without fee provided that copies are not made or distributed for profit or commercial advantage and that copies bear this notice and the full citation on the first page. Copyrights for third-party components of this work must be honored. For all other uses, contact the owner/author(s).

Woodstock '18, June 03–05, 2018, Woodstock, NY

© 2020 Copyright held by the owner/author(s).

ACM ISBN 978-x-xxxx-xxxx-x/YY/MM.

<https://doi.org/10.1145/nnnnnnn.nnnnnnn>

¹wdt: binds to <https://www.wikidata.org/wiki/>

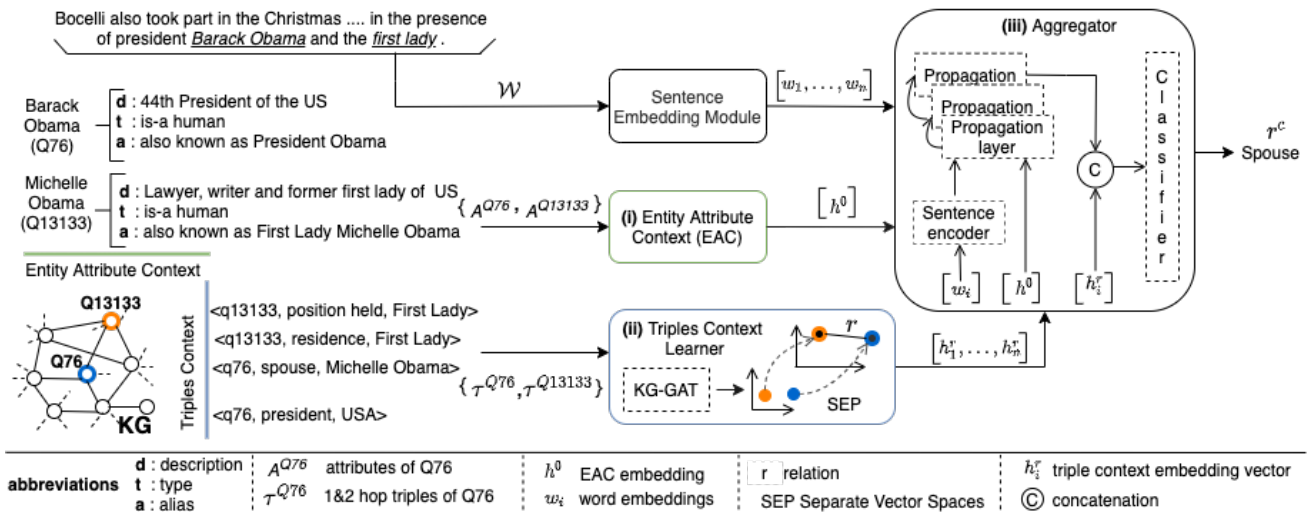

Figure 1: RECON has three building blocks: i) entity attribute context (EAC) encodes context from entity attributes ii) triple context learner independently learns relation and entity embeddings of the KG triples in separate vector spaces iii) a context aggregator (a GNN model) used for consolidating the KG contexts to predict target relation.

proposing a novel method RECON. RECON focuses on effective representation of the knowledge derived from the KG induced in a graph neural network (GNN). The proposed approach has three building blocks illustrated in the Figure 1. Specifically, RECON harnesses the following three novel insights to outperform existing sentential and multi-instance RE methods:

- *Entity Attribute Context*: we propose a recurrent neural network based module that learns representations of the given entities expanded from the KG using entity attributes (properties) such as *entity label*, *entity alias*, *entity description* and *entity Instance of (entity type)*.
- *Triple Context Learner*: we aim to utilize a graph attention mechanism to capture both entity and relation features in a given entity’s multi-hop neighborhood. By doing so, our hypothesis is to supplement the context derived from the previous module with the additional neighborhood KG triple context. For the same, the second module of RECON independently yet effectively learns entity and relation embeddings of the 1&2-hop triples of entities using a graph attention network (GAT) [22].
- *Context Aggregator*: our idea is to exploit the message passing capabilities of a graph neural network [30] to learn representations of both the sentence and facts stored in a KG. Hence, in the third module of RECON, we employ an aggregator consisting of a GNN and a classifier. It receives as input the sentence embeddings, entity attribute context embeddings, and the triple context embeddings. The aggregator then obtains a homogeneous representation, passed into a classifier to predict the correct relation.

We perform exhaustive evaluation to understand the efficacy of RECON in capturing the KG context. Our work has following contributions:

- RECON: a sentential RE approach that utilizes entity attributes and triple context derived from the Web scale knowledge graphs, induced in a GNN, thereby significantly outperforming the existing baselines on two standard real world datasets.
- We augment two datasets: Wikidata dataset [20] and NYT dataset for Freebase [17] with KG context. Our implementation and datasets are publicly available: *blindreview*.

The structure of the paper is follows: Section 2 reviews the related work. Section 3 formalizes the problem and the proposed approach. Section 4 describes experiment setup. Our results are illustrated in Section 5. We conclude in Section 6.

2 RELATED WORK

Multi-instance RE: The recent success in RE can attribute to the availability of vast training data curated using distant supervision [15]. Methods for distant supervision assume that if two entities have a relationship in a KG, then all sentences containing those entities express the same relation, this may sometimes lead to noise in the data. To overcome the challenges, researchers in [17] initiated the multi-instance learning followed by [7] which extracted relation from a bag of sentences. For detailed survey on multi-instance RE, please refer to [19].

Researchers [10] attained improved performance by introducing entity descriptions as KG context to supplement the task. The RESIDE approach [21] ignores entity descriptions but utilize entity type along with relation and entity aliases. RELE approach [9] jointly learned embeddings of structural information from KGs and textual data from entity descriptions to improve multi-instance RE. Unlike existing approaches where one or other entity attributes are considered, in this work, we combined four typical properties of KG entities for building what we refer as entity attribute context.

Learning information from KG Triples: The survey [24] provides holistic overview of available KG embedding techniques and their application in entity oriented tasks. TransE [3] studied knowledge base completion task using entity and relation embeddings learned in the same vector space. It lacks ability to determine one-to-many, many-to-one, and many-to-many relations. TransH [25] has tried to address this problem by learning embeddings on different hyperplanes per relation. However, the entity and relation embeddings are still learned in the same space. TransR [12] represents entity and relation embeddings in separate vector spaces, which works better on the task of relation prediction and triple classification. They perform a linear transformation from entity to relation embedding vector space. Work by [27] and [6] are few attempts for jointly learning different representations from text and facts in an existing knowledge graph. Furthermore, graph attention network (GAT) has been proposed to learn embeddings for graph-structured data [22]. KBGAT is an extension of GAT that embeds KG triples by training entities and relations in same vector spaces specifically for relation prediction [16]. However, we argue that entity and relation embedding space should be separated. Moreover, the transformation from entity to relation space should be nonlinear and distinct for every relation. This setting allows the embeddings to be more expressive (section 5).

Sentential RE: There exists a little work on the sentential RE task. The work in [20] established an LSTM-based baseline that learns context from other relations in the sentence when predicting the target relation. [30] generate the parameters of graph neural networks (GP-GNN) according to natural language sentences for multi-hop relation reasoning for the entity pair. In this paper, our idea is to utilize the ability of GP-GNN for rich message passing between entity nodes for effectively learning the KG context.

3 PROBLEM STATEMENT AND APPROACH

3.1 Problem Statement

We define a KG as a tuple $KG = (\mathcal{E}, \mathcal{R}, \mathcal{T}^+)$ where \mathcal{E} denotes the set of entities (vertices), \mathcal{R} is the set of relations (edges), and $\mathcal{T}^+ \subseteq \mathcal{E} \times \mathcal{R} \times \mathcal{E}$ is a set of all triples. A triple $\tau = (e_h, r, e_t) \in \mathcal{T}^+$ indicates that, for the relation $r \in \mathcal{R}$, e_h is the head entity (origin of the relation) while e_t is the tail entity. Since KG is a multigraph; $e_h = e_t$ may hold and $|\{r_{e_h, e_t}\}| \geq 0$ for any two entities. We define the tuple $(A^e, \tau^e) = \varphi(e)$ obtained from a context retrieval function φ , that returns, for any given entity e , two sets: A^e , a set of all attributes and $\tau^e \subset \mathcal{T}^+$ the set of all triples with head at e .

A sentence $\mathcal{W} = (w_1, w_2, \dots, w_l)$ is a sequence of words. The set of entities mentioned in a sentence is denoted by $\mathcal{M} = \{m_1, m_2, \dots, m_k\}$ where every $m_k = (w_i, \dots, w_j)$ is a segment of the sentence \mathcal{W} . Each mention is annotated by an entity from KG as $[m_i : e_j]$ where $e_j \in \mathcal{E}$. Two annotated entities form a pair $p = \langle e_b, e_t \rangle$ when there exists a relationship between them in the sentence (note that there may exist a relationship in the sentence but no relation in the KG - label N/A).

The *RE Task* predicts the target relation $r^c \in \mathcal{R}$ for a given pair of entities (e_i, e_j) within the sentence \mathcal{W} . If no relation is inferred, it returns 'NA' label. We attempt the *sentential RE* task which posits that the sentence within which a given pair of entities occurs is the only visible sentence from the bag of sentences. All other sentences

in the bag are not considered while predicting the correct relation r^c . Similar to other researchers [20], we view RE as a classification task. However, we aim to model KG contextual information to improve the classification. This is achieved by learning representations of the sets A^e , τ^e , and \mathcal{W} as described in section 3.2.

3.2 RECON Approach

We now detail the three modules of RECON (also, see Figure 1).

3.2.1 Entity Attribute Context (EAC). The entity attribute context is built from commonly available properties of a KG entity [8]: *entity labels*, *entity alias*, *entity description*, and *entity Instance of*. We extract this information for each entity from the public dump of Freebase [2], and Wikidata [23]) depending on the underlying KG (cf. section 4). To formulate our input, we consider the literals of the retrieved entity attributes. For each of these attributes, we concatenate the word and character embeddings and pass them through a bidirectional-LSTM encoder [18]. The final outputs from the BiLSTM network are stacked and given to a one dimensional convolution network (CNN) described in the Figure 2 and formalized in equation 1. The reasons behind choosing CNN are i) to enable a dynamic number of contexts using the max pooling ii) to keep the model invariant of the order in which the context is fed.

$$h^o = \text{1D_CNN}(\|_{i=0}^N [\text{BiLSTM}(A_i)]) \quad (1)$$

where each A_i is attribute of given entity and $\|$ is the concatenation.

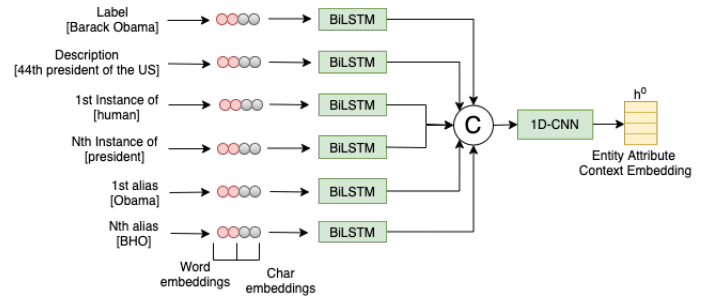

Figure 2: Entity Attribute Context Module

3.2.2 Triple Context Learner (KGGAT-SEP). The *KG triple context learner (KGGAT-SEP)* is an extension of KBGAT [16] that retains the capability to capture context from neighboring triples in the KG. In addition, our idea is to learn the entity and relation embeddings of the triples in separate vector spaces to capture more expressive representations. This is because each entity might be engaged in several relations in various contexts, and different aspects of the entity may participate in representing each relation [12]. Let \vec{e}_h and \vec{e}_t be the initial entity vectors and \vec{r}_k be a initial relation vector between them representing the triple τ_{htk} , W is the weight metric, then the vector representation of triple is

$$\vec{\tau}_{htk} = W[\vec{e}_h \parallel \vec{e}_t \parallel \vec{r}_k] \quad (2)$$

where we concatenate the head and tail entity embeddings and relation embedding vector. The importance of each triple (i.e. attention

values) is represented by b_{htk} and is computed as in equation 3 where $LeakyReLU$ is an activation function:

$$b_{htk} = LeakyReLU(W_2 \vec{\tau}_{htk}) \quad (3)$$

To get the relative attention values over the neighboring triples, a softmax is applied to equation 3

$$\alpha_{htk} = softmax_{t,k}(b_{htk}) = \frac{\exp(b_{htk})}{\sum_{t \in N_h} \sum_{r \in R_{ht}} \exp(b_{htk})} \quad (4)$$

N_h denotes the neighborhood of entity e_h and R_{ht} denotes the set of relations between entities e_h and e_t . The new embedding for the entity e_h is now the weighted sum of the triple embeddings using equations 2 and 4. In order to stabilize the learning and encapsulate more information, X independent attention heads have been used and the final embedding is the concatenation of the embedding from each head:

$$\vec{e}_h' = \sum_{x=1}^X \sigma_x \odot \vec{e}_h^{\otimes x} \quad (5)$$

The original entity embedding \vec{e}_h after a transformation, using matrix W^E , is added to the equation 5 to preserve the initial entity embedding information.

$$\vec{e}_h'' = \vec{e}_h' + W^E \vec{e}_h \quad (6)$$

For relation embeddings, a linear transformation is performed on the initial embedding vector, using matrix W^R , to match the entity vector's dimension in equation 6

$$\vec{r}_k'' = W^R \vec{r}_k \quad (7)$$

Traditionally, the training objective for learning embeddings in same vector spaces are borrowed from [3]. The embeddings here are learned such that, for a valid triple $\tau_{htk} = (e_h, r_k, e_t)$ the following equation holds

$$\vec{e}_h'' + \vec{r}_k'' = \vec{e}_t'' \quad (8)$$

The optimization process tries to satisfy equation 8 and the vectors are learned in *same vector space*. Contrary to the previous equation, we keep entities and relation embeddings in **separate spaces**. With that, we now need to transform entities from entity spaces to the relation space. We achieve this by applying a nonlinear transformation: (cf. the theoretical foundation behind our choice is in the submitted appendix (section 7.1).

$$\vec{e}_i^r = \sigma(W_r \vec{e}_h'') \quad (9)$$

here \vec{e}_i^r (where $i = \{h, t\}$) is the relation specific entity vector in the relation embedding space, W_r is the relation specific transformation matrix and \vec{e}_h'' is the corresponding embedding in the entity space from equation 6. We presume that such separation helps to capture a comprehensive representations for relations and entities. Equation 8 is now modified as

$$\vec{e}_h^r + \vec{r}_k'' = \vec{e}_t^r \quad (10)$$

We define a distance metric d_{ht} for a relation \vec{r}_k'' , representing the triple τ_{htk} as

$$d_{\tau_{htk}} = \vec{e}_h^r + \vec{r}_k'' - \vec{e}_t^r \quad (11)$$

A margin ranking loss minimizes the following expression

$$L(\Omega) = \max_{\tau_{ht} \in \mathcal{T}^{pos}} \min_{\tau_{ht}' \in \mathcal{T}^{neg}} \{d_{\tau_{ht}'} - d_{\tau_{ht}} + \gamma, 0\} \quad (12)$$

where \mathcal{T}^{pos} is the set of valid triples, \mathcal{T}^{neg} is the set of invalid triples and γ is a margin parameter. We consider the actual triples present in the dataset as positive (valid) triples and the rest of the triples, which are not in the dataset as invalid.

3.2.3 Aggregating KG Context. For aggregating context from previous two steps, we adapt and modify generated parameter graph neural network (GP-GNN) [30] due to its proven ability to enable message passing between nodes. It consists of an encoder module, a propagation module and a classification module. Encoder takes as input the word vectors concatenated to the position vectors from the sentence.

$$E(w_s^{i,j}) = w_s \parallel p_s^{i,j} \quad (13)$$

where p is position vector and w is the word embedding. Position vectors are basically to mark whether the token belongs to head or tail entity or none of them. We use position embedding scheme from [30]. We use concatenated word embeddings in a biLSTM followed by a fully connected network for generating transition matrix:

$$B_{(i,j)} = [MLP(BiLSTM^{n-1}(E(w_s^{i,j})_{s=1}^l))] \quad (14)$$

Here $[.]$ denotes conversion of vectors into a matrix, lyr is the layer of biLSTM, s is the index of word in sentence and l is the length of the sentence. For each layer (n) of the propagation module we learn a matrix $B_{i,j}^{(n)}$ using equation 14. Then, the propagation module learns representations of entity nodes v (layer wise) according to the following equation

$$h_i^{(n+1)} = \sum_{v_j \in N(v_i)} \sigma(B_{i,j}^{(n)} h_j^{(n)}) \quad (15)$$

$N(v_i)$ represents the neighborhood of v_i . Here h^0 is the initial entity embedding which is taken from equation 1. For the classification module the vectors learned by each layer in the propagation module are concatenated and used for linking the relation between the two entities.

$$r_{v_i, v_j} = \prod_{i=1}^N [h_{v_i}^{(i)} \odot h_{v_j}^{(j)}]^\top \quad (16)$$

where \odot denotes element wise multiplication. We concatenate the entity embeddings learned from the triples context in equation 6 to r_{v_i, v_j} obtained from 16 and feed into classification layer to get the probability of each relation

$$P(r | h, t, s) = softmax(MLP[r_{v_i, v_j} \parallel \vec{e}_h'' \parallel \vec{e}_t'']) \quad (17)$$

where \vec{e}_h'' and \vec{e}_t'' are the entity embeddings learned from previous module in equation 6.

Aggregating the separate space embeddings: The probability in equation 17 uses the embeddings learned in the same vector space. For the embeddings learned in separate vector spaces, we compute the similarity of the logits with the corresponding relation vector i.e. we use the embedding learned in equation 9 to find the probability of a triple exhibiting a valid relation. For this we concatenate the entity embeddings from equation 9 with the Equation 16. This is then transformed as below:

$$v_{ht} = \sigma(W[r_{e_h, e_t} \parallel \vec{e}_h^r \parallel \vec{e}_t^r]) \quad (18)$$

Where v_{htr} is a vector obtained by applying a non-linear function σ on the final representation in the aggregator. We then compute the distance between this embedding and the relation vector \vec{r} (aka \vec{r}_k'') obtained in the equation 7 to get the probability of the relation existing between the two entities.

$$P(r | h, t, s, A, G) = \sigma \vec{r}^\top v_{htr} \quad (19)$$

where h, t are the head and tail entities, s is the sentence, A is the context, and G is the computed graph. Optimizing equation 19 using binary cross entropy loss with negative sampling on the invalid triples is computationally expensive. Hence, we obtain the combined entity vector by applying attention over the embeddings using the encoder vector in equation 14 as the query and the relation vectors in equation 7 as the key.

$$b_{ir} = \vec{r}^\top W(\text{BiLSTM}(E(w_s^{i,j})_{s=1}^l)) \quad (20)$$

$$\alpha_{ir} = \text{softmax}_r(b_{ir}) = \frac{\exp(b_{ir})}{r \in R \exp(b_{ir})} \quad (21)$$

$$\vec{e}_i^{attn} = \sum_{r \in R} \alpha_{ir} \vec{e}_i^r \quad (22)$$

α_{ir} is attention value of the entity embedding e_i and relation r . The \vec{e}_i^{attn} is concatenated with the vectors learned from the propagation stage and entity embeddings to classify the target relation.

$$P(r | h, t, s) = \text{softmax}(\text{MLP}([r_{v_i}, v_j \parallel \vec{e}_h \parallel \vec{e}_t \parallel \vec{e}_h^{attn} \parallel \vec{e}_t^{attn}])) \quad (23)$$

4 EXPERIMENTAL SETUP

4.1 Datasets

We use two standard datasets for our experiment. (i) *Wikidata dataset* [20] created in a distantly-supervised manner by linking the Wikipedia English Corpus to Wikidata and includes sentences with multiple relations. It has 353 unique relations, 372,059 sentences in training, and 360,334 for testing. (ii) *NYT Freebase dataset* which was annotated by linking New York Times articles with Freebase KG [17]. This dataset has 53 relations (including no relation $\hat{\Delta}\hat{\Delta}\hat{\Delta}$). The number of sentences in training and test set are 455,771 and 172,448 respectively. We augment both datasets with our proposed context. For EAC, we used dumps of Wikidata² and Freebase³ to retrieve entity properties. In addition, the 1&2 hop triples are retrieved from the local KG associated with each dataset.

4.2 RECON Configurations

We configure RECON model applying various contextual input vectors detailed below:

KGGAT-SEP: this implementation encompasses only KGGAT-SEP module of RECON (cf. section 3.2.2) which learns triple context. This is for comparing against [16].

RECON-EAC: induces encoded entity attribute context (from section 3.2.1) along with sentence embeddings into the propagation layer of context aggregator module.

RECON-EAC-KGGAT: along with sentence embeddings, it consumes both types of context i.e., entity context and triple context

(cf. section 3.2.2) where relation and entity embeddings from the triples are trained on same vector space.

RECON: similar to RECON-EAC-KGGAT, except entity and relation embeddings for triple context learner are trained in different vector spaces.

4.3 Comparative Models

We consider the recent state-of-the-art approaches for our comparison study as follows:

KBGAT [16]: this open-source implementation is compared with our KGGAT-SEP for evaluating the effectiveness of our approach in learning the KG triple context.

Context-Aware LSTM [20]: learns context from other relations in the sentence. We reuse its open-source code.

GP-GNN [30]: proposes multi-hop reasoning between the entity nodes for sentential RE. We employ the open source code.

Sorokin-LSTM [20]: NYT Freebase dataset contains one relation per sentence, but Context-Aware LSTM has a prerequisite of having at least two relations in a sentence. Hence, we reuse another baseline, which is an LSTM model without a sentential relation context.

Multi-instance RE approaches: these approaches consider context from the surrounding text of a given sentence whereas Sentential RE limits context only to the given sentence. Our idea is to observe if inducing KG context into a sentential RE model can be a good trade-off against a multi-instance setting. Hence, we compare RECON and other sentential RE baselines (Sorokin-LSTM & GP-GNN) with the multi-instance RE models. For this, we rely on the NYT Freebase dataset, since the other dataset does not have multiple instances for an entity pair. **HRERE** [27] is the multi-instance SOTA on NYT Freebase dataset that jointly learns different representations from text and KG facts. For the completion of the comparison, performance of four previous baselines are also reported i.e., (i) **Wu-2019** [26], (ii) **Yi-Ling-2019** [28], (iii) **RESIDE** [21], and iv) **PCNN+ATTN** [13]. The values are taken from the respective papers, further verified from an authentic Github repo⁴.

4.4 Hyperparameters and Metric

The EAC module (section 3.2.1) uses a biLSTM with one hidden layer of size 50. The convolution filter is of width one, and the output size is 8. In KGGAT-SEP (section 3.2.2), the initial entity and relation embedding size is 50, number of heads are two with two GAT layers, and the final entity and relation embedding size is 200. For the context aggregator module, we adapt the parameters provided in GP-GNN [30]. The word embedding dimension is 50 initialized from the Glove embeddings. The position embedding is also kept at 50 dimensions. Encoder uses a layer of bidirectional LSTM of size 256. We use three propagation layers with the entity embedding dimension set at 8. For brevity, complete training details are in the public Github.

Metric and Optimization: Similar to baseline, we ignore probability predicted for the NA relation during testing on both datasets. We use different metrics depending on the dataset as per the respective baselines for fair comparison. On Wikidata dataset, we adapt (micro and macro) precision (P), recall (R), and F-score (F1) from [20]. For

²<https://dumps.wikimedia.org/wikidatawiki/entities/>

³<https://developers.google.com/freebase>

⁴https://github.com/sebastianruder/NLP-progress/blob/master/english/relationship_extraction.md

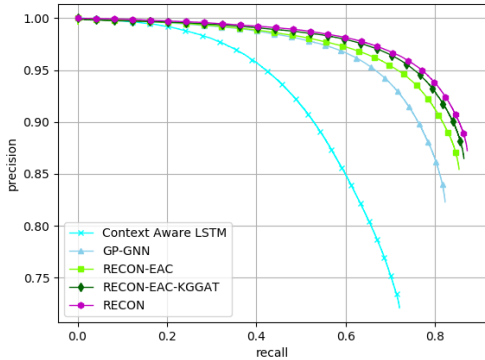

(a) Micro P-R Curve

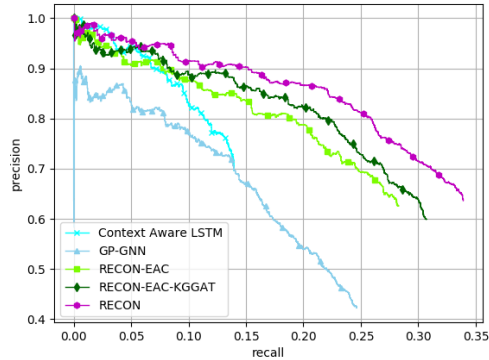

(b) Macro P-R Curve

Figure 3: The P-R curves for Sentential RE approaches on Wikidata Dataset. RECON and its configurations maintain a higher precision (against the baselines) over entire recall range.

NYT Freebase dataset, we follow the work by [27] that uses (micro) P@10 and P@30. An ablation is performed to measure effectiveness of KGGAT-SEP in learning entity and relation embeddings. For this, we use the hits@N, average rank, and average reciprocal rank in similar to [16]. Our work employs the Adam optimizer [11] with categorical cross entropy loss where each model is run three times on the whole training set. For the P/R curves, we select the results from the first run of each model.

Model	Micro			Macro		
	P	R	F1	P	R	F1
Context-Aware LSTM [20]	72.09	72.06	72.07	69.21	13.96	17.20
GP-GNN [30]	82.30	82.28	82.29	42.24	24.63	31.12
RECON-EAC	85.44	85.41	85.42	62.56	28.29	38.96
RECON-EAC-KGGAT	86.48	86.49	86.48	59.92	30.70	40.60
RECON	87.24	87.23	87.23	63.59	33.91	44.23

Table 1: Comparison of RECON and sentential RE models on the Wikidata dataset. Best values are in bold. Each time a KG context is added in a graph neural network, the performance has increased, resulting in a significant RECON outperformance against all sentential RE baselines.

5 RESULTS

We study the research question: "How effective is RECON in capturing the KG context induced in a graph neural network for the sentential RE?"

Performance on Wikidata dataset: Table 1 summarizes the performance of RECON and its configurations against other sentential RE models. It can be observed that by adding the entity attribute context (RECON-EAC), we surpass the baseline results. The RECON-EAC-KGGAT values indicate that when we further add context from KG triples, there is an improvement. However, the final configuration RECON achieves the best results. It validates our hypothesis that RECON is able to capture the KG context effectively. The P/R curves are illustrated in the Figure 3. RECON steadily achieves

higher precision over the entire recall range compared to other models. In running example (cf. Figure 1), RECON could predict the correct relation *wdt:P26* (*spouse*) between *wdt:Q76* (*Barack Obama*) and *wdt:Q13133* (*Michelle Obama*), while, the other two baselines wrongly predicted the relation *wdt:P155* (*follows*).

Performance on NYT Freebase Dataset: RECON and its configurations again outperform the sentential RE baselines, as illustrated in the Table 2. Hence, independent of underlying KG, RECON can still capture sufficient context collectively from entity attributes and factual triples. We also compare the performance of sentential RE models, including RECON and its configurations against multi-instance RE baselines. It can be deduced from Table 2 that RECON also outperforms multi-instance baselines. RECON also maintain higher precision over longer recall range. This could be interpreted as follows: adding context from the underlying knowledge graph instead of the bag of sentences for the entity pairs keeps the precision higher over a more extended recall range.

Task	Model	Precision	
		@10%	@30%
Sentential	Sorokin-LSTM [20]	75.4	58.7
	GP-GNN [30]	81.3	63.1
	RECON-EAC	83.5	73.4
	RECON-EAC-KGGAT	86.2	72.1
	RECON	87.5	74.1
Multi-instance	HREER [27]	84.9	72.8
	Wu-2019 [26]	81.7	61.8
	Ye-Ling-2019 [28]	78.9	62.4
	RESIDE [21]	73.6	59.5
	PCNN+ATTN [13]	69.4	51.8

Table 2: Comparison of RECON against baselines (sentential and multi-instance) on the NYT Freebase dataset. Best values are in bold. RECON continues to significantly outperform sentential RE baselines and also surpasses the performance of state of the art multi-instance RE approach.

Compared Models	Contingency		Statistic	p-value	Dataset
GP-GNN Vs	568469	40882	4978.84	0.0	Wikidata
RECON-EAC	63702	67713			
RECON-EAC Vs	599135	33036	862.38	$1.5 * 10^{-189}$ *	Wikidata
RECON-EAC-KGGAT	41029	67566			
RECON-EAC-KGGAT	608442	31722	455.29	$5.1 * 10^{-101}$ *	Wikidata
Vs RECON	37330	63272			
GP-GNN Vs	158426	4936	15.72	$7.3 * 10^{-9}$	Freebase
RECON-EAC	53392	3699			
RECON-EAC Vs	160227	3538	59.44	$1.2 * 10^{-14}$	Freebase
RECON-EAC-KGGAT	4218	4417			
RECON-EAC-KGGAT	161012	3433	54.88	$1.3 * 10^{-13}$	Freebase
Vs RECON	4076	3879			

Table 3: The McNemar’s test for statistical significance on both datasets. It can be observed that each of the improvement in RECON configurations is statistically significant independent of the underlying KG.

5.1 Ablation Studies

Effectiveness of EAC: We separately studied each entity attribute’s effect on the performance of the RECON-EAC configuration for both datasets. Table 4 and Table 5 summarizes the contribution of the four entity attributes when independently added or one entity attribute is systematically removed from the model on Wikidata and Freebase datasets, respectively. We see that the entity descriptions significantly impact the performance on Wikidata dataset, while entity type (Instance-of) contributes the least across both datasets. The entity aliases have highest impact on NYT freebase dataset. Nevertheless, once we induce cumulative context from all entity attributes, we attain a major jump in the RECON-EAC performance independent of the underlying KG (cf. Table 1 and Table 2).

Model	P	R	F
RECON-EAC(Instance of)	76.33	76.32	76.32
RECON-EAC(label)	78.64	78.70	78.67
RECON-EAC(Alias)	81.58	81.56	81.57
RECON-EAC(Description)	83.16	83.18	83.17

Table 4: RECON-EAC performance on Wikidata Dataset. The rows comprise of the configuration when context from each entity attribute is added in isolation. We report micro P, R, and F scores. (Best score in bold)

Model	P@10	P@30
RECON-EAC(Instance of)	71.83	57.52
RECON-EAC(label)	78.14	66.34
RECON-EAC(Alias)	80.60	67.13
RECON-EAC(Description)	72.40	67.11

Table 5: RECON-EAC performance on NYT Freebase Dataset. The rows comprise of the configuration when context from each entity attribute is added in isolation. We report P@10 and P@30 (Best score in bold).

Understanding the KG triple Context:

To understand the effect of relying on one single embedding space or two separate spaces, we conducted an ablation study for the triple classification task on Wikidata dataset. We performed a ranking of all the triples for a given entity pair and obtained hits@N, average rank, and Mean Reciprocal Rank (MRR). Hits@10 signifies that which portion of the top 10 triples has a positive impact on the performance. Table 7 illustrates that the KGGAT-SEP (separate spaces) exceeds KBGAT (single space) by a large margin on the triple classification task. Training in separate vector spaces facilitates learning of more expressive embeddings of the entities and relations in triple classification task. However, when we trained entity and relation embeddings of KG triples in separate spaces, improvements are marginal for sentential RE task (cf. Table 1). We could interpret this behavior as the model may have already learned relevant information from the sentence and the tripe context before we separate vector spaces. Also, in our case the computed graph is sparse for sentential RE i.e. there are few relations per entity that prevents effective learning of good representation [16]. We believe sparseness of the computed graph may have prevented effective learning of the entity embeddings. It requires further investigation and we plan it for our future work.

Statistical Significance of RECON: The McNemar’s test for statistical significance has been used to find if the reduction in error at each of the incremental stages in RECON are significant. The test is primarily used to compare two supervised classification models [4]. The results are shown in table 3. For the column "contingency table" (2x2 contingency table), the values of the first row and second column (RW) represent the number of instances that model 1 predicted correctly and model 2 incorrectly. Similarly the values of the second row and first column gives the number of instances that model 2 predicted correctly and model 1 predicted incorrectly (WR). The statistic here is

$$\frac{(RW - WR)^2}{RW + WR}$$

The differences in the models are said to be statistically significant if the $p - value < 0.05$ [4]. On both datasets, for all RECON configurations, the results are statistically significant, illustrating our approach’s robustness. In the contingency table, the (RW) values provide an exciting insight. For example, in the first row of the table, there are 40882 sentences for which adding the RECON-EAC context has negatively resulted in the performance compared to GP-GNN. There are 31722 sentences in the Wikidata dataset for which the KG context has negatively impacted the RECON performance. This opens up a new research question that how can one intelligently select the KG context based on the sentence before feeding it into the model? We leave the detailed exploration of the observed behavior for future work.

5.1.1 Case Study. Table 6 demonstrates RECON’s performance against two sentential baselines: Context-Aware LSTM [20] and GP-GNN [30] on five randomly selected sentences from the Wikidata dataset. We can see that these sentences don’t directly contain much information regarding the potential relationship between two entities (the relations are implicitly coded in the text). For example, in the first sentence, the relation between the entities rapper and Eminem is "occupation." The baselines predicted "Instance of" as the

Sentence	Entities	Correct Relation	Context-Aware LSTM[20]	GP-GNN[30]	RECON
1. Specifically , the rapper listed Suzanne Vega , Led Zeppelin , Talking Heads , Eminem , and Spice Girls.	Q5608 : rapper Q62943 : Eminem	P106 Occupation	P31 Instance of	P31 Instance Of	P106 Occupation
2. During the reign of Ashoka (304 232 BCE), Kashmir became a part of the Maurya Empire and Buddhism was introduced in Kashmir .	Q8589 : Ashoka Q62943 : Maurya Empire	P27 country of citizenship	P17 country	P17 country	P27 country of citizenship
3. Bocelli also took part in the Christmas in Washington special on Dec 12, in the presence of president Barack Obama and the first lady	Q76 : Barack Obama Q13133 : Michelle Obama	P26 spouse	P155 follows	P155 follows	P26 spouse
4. It was kept from number one by Queen’s Bohemian Rhapsody	Q15862 : Queen Q187745 : Bohemian Rhapsody	P175 performer	P50 author	P50 author	P175 performer
5. These diseases include peritoneal mesothelioma, lung cancer, asbestosis, diffuse pleural thickening and other pleural abnormalities	Q47912 : Lung cancer Q664174 : Asbestosis	P828 has cause	P279 subclass of	P279 subclass of	P828 has cause

Table 6: Sample sentence examples from the Wikidata dataset. RECON is able to predict the relations which are not explicitly observable from the sentence itself.

Model	%Hits @10	MR	MRR	Dataset
KBGAT	65.8	35.2	0.36	Wikidata
KGGAT-SEP	72.6	29	0.38	Wikidata

Table 7: Comparing KGGAT-SEP and KBGAT for triple classification task on both Datasets. Best score is in bold.

target relation considering sentential context is limited. However, the Wikidata description of the entity Q8589(Eminem) is "American rapper, producer and actor". Once we feed description in our model as context for this sentence, RECON predict the correct relation.

6 CONCLUSION AND FUTURE DIRECTIONS

This paper presents RECON, a sentential RE approach that integrates sufficient context from a background KG. Our empirical study shows that KG context provides valuable additional signals when the context of the RE task is limited to a single sentence. Gleaning from our evaluations, we conclude three significant findings: i) the simplest form of KG context like entity description already provide ample signals to improve the performance of GNNs. We also see that proper encoding of combined entity attributes (labels, descriptions, instance of, and aliases) results in a more amicable representation. ii) Although graph attention networks provide one of the best avenue to encode KG triples, more expressive embeddings can be achieved when entity and relation embeddings are learned in separate vector spaces. iii) Finally, due to the proposed KG context and encoding thereof, RECON transcends the SOTA in sentential RE while also achieving SOTA results against multi-instance RE models. We submit that sentential RE models induced with effectively learned KG context could be a good trade-off compared to the multi-instance setting. We expect the research community to look deeper into this potential trade-off for relation extraction.

For future work, we suggest further investigation on optimizing the training of embeddings in separate vector spaces for RE. We also found that combining the triple context with the entity attribute

context offered minimal gain to the model. Hence, we recommend jointly training the entity attribute and triple context as a viable path for future work.

REFERENCES

- [1] Sören Auer, Christian Bizer, Georgi Kobilarov, Jens Lehmann, Richard Cyganiak, and Zachary G. Ives. 2007. DBpedia: A Nucleus for a Web of Open Data. In *The Semantic Web, 6th International Semantic Web Conference, 2nd Asian Semantic Web Conference, ISWC 2007 + ASWC 2007, Busan, Korea, November 11-15, 2007*.
- [2] Kurt D. Bollacker, Robert P. Cook, and Patrick Tufts. 2007. Freebase: A Shared Database of Structured General Human Knowledge. In *AAAI 2007*.
- [3] Antoine Bordes, Nicolas Usunier, Alberto García-Durán, Jason Weston, and Oksana Yakhnenko. 2013. Translating Embeddings for Modeling Multi-relational Data. In *27th Annual Conference on Neural Information Processing Systems 2013*. 2787–2795.
- [4] Thomas G Dietterich. 1998. Approximate statistical tests for comparing supervised classification learning algorithms. *Neural computation* 10, 7 (1998), 1895–1923.
- [5] Dieter Fensel, Umutcan Şimşek, Kevin Angele, Elwin Huaman, Elias Kärle, Oleksandra Panasiuk, Ioan Toma, Jürgen Umbrich, and Alexander Wahler. 2020. Why We Need Knowledge Graphs: Applications. In *Knowledge Graphs*. Springer, 95–112.
- [6] Xu Han, Zhiyuan Liu, and Maosong Sun. 2018. Neural Knowledge Acquisition via Mutual Attention Between Knowledge Graph and Text. In *Proceedings of the Thirty-Second AAAI Conference on Artificial Intelligence, (AAAI-18)*, Sheila A. McIlraith and Kilian Q. Weinberger (Eds.). AAAI Press, 4832–4839.
- [7] Raphael Hoffmann, Congle Zhang, Xiao Ling, Luke S. Zettlemoyer, and Daniel S. Weld. 2011. Knowledge-Based Weak Supervision for Information Extraction of Overlapping Relations. In *The 49th Annual Meeting of the Association for Computational Linguistics: Human Language Technologies, Proceedings of the Conference*. The Association for Computer Linguistics, 541–550.
- [8] Aidan Hogan, Eva Blomqvist, Michael Cochez, Claudia d’Amato, Gerard de Melo, Claudio Gutierrez, Jose Emilio Labra Gayo, Sabrina Kirrane, Sebastian Neumaier, Axel Polleres, et al. 2020. Knowledge graphs. (2020).
- [9] Linmei Hu, Luhao Zhang, Chuan Shi, Liqiang Nie, Weili Guan, and Cheng Yang. 2019. Improving Distantly-Supervised Relation Extraction with Joint Label Embedding. In *Proceedings of the 2019 Conference on Empirical Methods in Natural Language Processing and the 9th International Joint Conference on Natural Language Processing, EMNLP-IJCNLP 2019*. Association for Computational Linguistics, 3819–3827.

- [10] Guoliang Ji, Kang Liu, Shizhu He, and Jun Zhao. 2017. Distant supervision for relation extraction with sentence-level attention and entity descriptions. In *Thirty-First AAAI Conference on Artificial Intelligence*.
- [11] Diederik P. Kingma and Jimmy Ba. 2015. Adam: A Method for Stochastic Optimization. In *3rd International Conference on Learning Representations, ICLR 2015, San Diego, CA, USA, May 7-9, 2015, Conference Track Proceedings*, Yoshua Bengio and Yann LeCun (Eds.).
- [12] Yankai Lin, Zhiyuan Liu, Maosong Sun, Yang Liu, and Xuan Zhu. 2015. Learning Entity and Relation Embeddings for Knowledge Graph Completion. In *Proceedings of the Twenty-Ninth AAAI Conference on Artificial Intelligence, January 25-30, 2015*. AAAI Press, 2181–2187.
- [13] Yankai Lin, Shiqi Shen, Zhiyuan Liu, Huanbo Luan, and Maosong Sun. 2016. Neural relation extraction with selective attention over instances. In *Proceedings of the 54th Annual Meeting of the Association for Computational Linguistics (Volume 1: Long Papers)*. 2124–2133.
- [14] Tianyu Liu, Kexiang Wang, Baobao Chang, and Zhifang Sui. 2017. A soft-label method for noise-tolerant distantly supervised relation extraction. In *Proceedings of the 2017 Conference on Empirical Methods in Natural Language Processing*. 1790–1795.
- [15] Mike Mintz, Steven Bills, Rion Snow, and Daniel Jurafsky. 2009. Distant supervision for relation extraction without labeled data. In *ACL 2009, Proceedings of the 47th Annual Meeting of the Association for Computational Linguistics and the 4th International Joint Conference on Natural Language Processing of the AFNLP*. The Association for Computer Linguistics, 1003–1011.
- [16] Deepak Nathani, Jatin Chauhan, Charu Sharma, and Manohar Kaul. 2019. Learning Attention-based Embeddings for Relation Prediction in Knowledge Graphs. In *Proceedings of the 57th Conference of the Association for Computational Linguistics, ACL Volume 1: Long Papers*. Association for Computational Linguistics, 4710–4723.
- [17] Sebastian Riedel, Limin Yao, and Andrew McCallum. 2010. Modeling Relations and Their Mentions without Labeled Text. In *Machine Learning and Knowledge Discovery in Databases, European Conference, ECML PKDD 2010, Proceedings, Part III (Lecture Notes in Computer Science)*, Vol. 6323. Springer, 148–163.
- [18] Mike Schuster and Kuldip K Paliwal. 1997. Bidirectional recurrent neural networks. *IEEE transactions on Signal Processing* 45, 11 (1997), 2673–2681.
- [19] Alisa Smirnova and Philippe Cudré-Mauroux. 2018. Relation extraction using distant supervision: A survey. *ACM Computing Surveys (CSUR)* 51, 5 (2018), 1–35.
- [20] Daniil Sorokin and Iryna Gurevych. 2017. Context-Aware Representations for Knowledge Base Relation Extraction. In *Proceedings of the 2017 Conference on Empirical Methods in Natural Language Processing, EMNLP 2017*. Association for Computational Linguistics, 1784–1789.
- [21] Shikhar Vashishth, Rishabh Joshi, Sai Suman Prayaga, Chiranjib Bhattacharyya, and Partha P. Talukdar. 2018. RESIDE: Improving Distantly-Supervised Neural Relation Extraction using Side Information. In *Proceedings of the 2018 Conference on Empirical Methods in Natural Language Processing*. Association for Computational Linguistics, 1257–1266.
- [22] Petar Veličković, Guillem Cucurull, Arantxa Casanova, Adriana Romero, Pietro Lio, and Yoshua Bengio. 2017. Graph attention networks. *arXiv preprint arXiv:1710.10903* (2017).
- [23] Denny Vrandečić. 2012. Wikidata: a new platform for collaborative data collection. In *Proceedings of the 21st World Wide Web Conference, WWW 2012, Lyon, France, April 16-20, 2012 (Companion Volume)*. 1063–1064.
- [24] Quan Wang, Zhendong Mao, Bin Wang, and Li Guo. 2017. Knowledge graph embedding: A survey of approaches and applications. *IEEE Transactions on Knowledge and Data Engineering* 29, 12 (2017), 2724–2743.
- [25] Zhen Wang, Jianwen Zhang, Jianlin Feng, and Zheng Chen. 2014. Knowledge Graph Embedding by Translating on Hyperplanes. In *Proceedings of the Twenty-Eighth AAAI Conference on Artificial Intelligence*. AAAI Press, 1112–1119.
- [26] Shanchan Wu, Kai Fan, and Qiong Zhang. 2019. Improving Distantly Supervised Relation Extraction with Neural Noise Converter and Conditional Optimal Selector. In *The Thirty-Third AAAI Conference on Artificial Intelligence, AAAI 2019*. AAAI Press, 7273–7280.
- [27] Peng Xu and Denilson Barbosa. 2019. Connecting Language and Knowledge with Heterogeneous Representations for Neural Relation Extraction. In *Proceedings of the 2019 Conference of the North American Chapter of the Association for Computational Linguistics: Human Language Technologies, NAACL-HLT 2019, Volume 1*. Association for Computational Linguistics, 3201–3206.
- [28] Zhi-Xiu Ye and Zhen-Hua Ling. 2019. Distant Supervision Relation Extraction with Intra-Bag and Inter-Bag Attentions. In *Proceedings of the 2019 Conference of the North American Chapter of the Association for Computational Linguistics: Human Language Technologies, NAACL-HLT 2019, Volume 1 (Long and Short Papers)*. Association for Computational Linguistics, 2810–2819.
- [29] Wenxuan Zhou, Hongtao Lin, Bill Yuchen Lin, Ziqi Wang, Junyi Du, Leonardo Neves, and Xiang Ren. 2020. Nero: A neural rule grounding framework for label-efficient relation extraction. In *Proceedings of The Web Conference 2020*. 2166–2176.
- [30] Hao Zhu, Yankai Lin, Zhiyuan Liu, Jie Fu, Tat-Seng Chua, and Maosong Sun. 2019. Graph Neural Networks with Generated Parameters for Relation Extraction. In *Proceedings of the 57th Conference of the Association for Computational Linguistics, ACL 2019, Volume 1: Long Papers*, Anna Korhonen, David R. Traum, and Lluís Màrquez (Eds.). Association for Computational Linguistics, 1331–1339.

7 APPENDIX

7.1 Theoretical Motivation

We define a set of theorems that motivated our approach RECON and to provide complimentary theoretical foundation to the approach.

LEMMA 7.1. *If entity and relation embeddings are expressed in the same vector space, there cannot be more than one distinct relation per entity pair*

PROOF. Consider two entities \vec{e}_1 and \vec{e}_2 . Consider a relation \vec{r}_1 between them. We want to have these vectors satisfy the triangle law of vector addition as below

$$\vec{e}_1 + \vec{r}_1 = \vec{e}_2 \quad (24)$$

Now assume another relation \vec{r}_2 between \vec{e}_1 and \vec{e}_2 (where \vec{e}_1 is the subject). Thus we have,

$$\vec{e}_1 + \vec{r}_2 = \vec{e}_2 \quad (25)$$

From lemmas 24 and 25 we get:

$$\vec{r}_1 = \vec{r}_2$$

□

LEMMA 7.2. *If entity and relation embeddings are expressed in the same vector space, there can not exist a single common relation between an entity and two different, directly connected entities*

PROOF. Consider \vec{e}_1 and \vec{e}_2 to have relation \vec{r}_1 . Consider \vec{e}_1 and \vec{e}_3 to have the same relation \vec{r}_1 . Then,

$$\vec{e}_1 + \vec{r}_1 = \vec{e}_2,$$

$$\vec{e}_1 + \vec{r}_1 = \vec{e}_3$$

$$\therefore \vec{e}_2 - \vec{e}_3 = \vec{0}$$

$$\vec{e}_2 = \vec{e}_3$$

We call this problem a mode collapse as the two separate entity embeddings collapse into a single vector.

□

LEMMA 7.3. *If entity and relation embeddings are expressed in the same vector space, there can be no entity sharing a common relation between two indirectly related entities*

PROOF. Consider \vec{e}_1 and \vec{e}_2 to have a relation \vec{r}_1 . Consider \vec{e}_1 and \vec{e}_3 to have a relation \vec{r}_3 . Let \vec{r}_1 and \vec{r}_3 be inverse relations. Assume $\vec{r}_1, \vec{r}_2 \neq 0$

$$\begin{aligned}\vec{r}_1 &= -\vec{r}_2 \\ \vec{e}_1 + \vec{r}_1 &= \vec{e}_2 \\ \vec{e}_1 + \vec{r}_2 &= \vec{e}_3 \\ \vec{e}_2 - \vec{e}_3 &= 2\vec{r}_1\end{aligned}$$

Now consider \vec{e}_4 to have a common relation with \vec{e}_2 and \vec{e}_3 . Let this relation be \vec{r}_3 .

$$\begin{aligned}\vec{e}_2 + \vec{r}_3 &= \vec{e}_4 \\ \vec{e}_3 + \vec{r}_3 &= \vec{e}_4 \\ \vec{e}_2 - \vec{e}_3 &= \vec{0} \\ \vec{r}_1 &= \vec{0}\end{aligned}$$

Which contradicts the assumption \square

LEMMA 7.4. *If f_r is an invertible and distributive function/transform for a relation \vec{r} , then for an entity sharing a common relation between two other distinct entities this function causes the embeddings of the two entities to be merged into one*

PROOF. Let's assume a transformation function f_r that transforms from the entity to the relation space. Assuming the triangle law holds we have,

$$\begin{aligned}f_r(\vec{e}_1) + \vec{r}_1 &= f_r(\vec{e}_2) \text{ and} \\ f_r(\vec{e}_1) + \vec{r}_1 &= f_r(\vec{e}_3) \\ \therefore f_r(\vec{e}_2) - f_r(\vec{e}_1) &= f_r(\vec{e}_3) - f_r(\vec{e}_1) \\ f_r(\vec{e}_2 - \vec{e}_1) &= f_r(\vec{e}_3 - \vec{e}_1) \dots \text{since } f_r \text{ is distributive} \\ f_r^{-1} * f_r(\vec{e}_2 - \vec{e}_1) &= f_r^{-1} * f_r(\vec{e}_3 - \vec{e}_1) \\ \dots \text{since } f_r \text{ is invertible} \\ \vec{e}_2 - \vec{e}_1 &= \vec{e}_3 - \vec{e}_1 \\ \vec{e}_2 &= \vec{e}_3\end{aligned}$$

However we may want to have \vec{e}_2 separate from \vec{e}_3 . \square

The affine transform as used by TransR[12] belongs to this class of transform. Hence we propose adding a non-linear transform.

LEMMA 7.5. *If \mathcal{T}_g is the set of triples learned under a common transform f_g and \mathcal{T}_l is the set of triples learned under a transform f_l which is distinct per relation then $\mathcal{T}_g \subsetneq \mathcal{T}_l$ i.e. \mathcal{T}_g is a strict subset of \mathcal{T}_l*

PROOF. We prove this lemma in two parts. First we show that $\mathcal{T}_g \subseteq \mathcal{T}_l$ then we show that $\mathcal{T}_l \not\subseteq \mathcal{T}_g$.

1. The first part is straightforward as we can set $f_l = f_g$ and make $\mathcal{T}_g \subseteq \mathcal{T}_l$

2. For showing the second part we consider the following system of triples Consider relations \vec{r}_1 and \vec{r}_2 between entities \vec{e}_1 and \vec{e}_2 and $\vec{r}_1 \neq \vec{r}_2$ We define a common transform f_g such that

$$\begin{aligned}f_g(\vec{e}_1) + \vec{r}_1 &= f_g(\vec{e}_2) \text{ and} \\ f_g(\vec{e}_1) + \vec{r}_2 &= f_g(\vec{e}_2) \\ \therefore \vec{r}_1 &= \vec{r}_2\end{aligned}$$

For the per relation transform we can define a function f_{r_1} for r_1 and f_{r_2} for r_2 such that

$$f_{r_1}(\vec{e}_1) + \vec{r}_1 = f_{r_1}(\vec{e}_2) \text{ and}$$

$$f_{r_2}(\vec{e}_1) + \vec{r}_2 = f_{r_2}(\vec{e}_2)$$

such that $\vec{r}_1 \neq \vec{r}_2$

Thus $\mathcal{T}_l \not\subseteq \mathcal{T}_g$, and hence the proof. \square

LEMMA 7.6. *If \mathcal{T}_{gca} is the set of triples that can be learned under a global context aware transform f_{gca} and \mathcal{T}_{lca} is the set of transforms learned under a local context aware transform then $\mathcal{T}_{lca} \subsetneq \mathcal{T}_{gca}$. By context here we mean the KG triples, global context refers to all the triples in the KG the current entities are a part of and local context means the triple under consideration.*

PROOF. We proceed similar to lemma 7.5.

1. We can make $f_{gca} = f_{lca}$ by ignoring the global context and thus $\mathcal{T}_{lca} \subseteq \mathcal{T}_{gca}$

2. We define a globally context aware transform as below:

$$\begin{aligned}f_{gca}(\vec{e}_1) &= f_r(\vec{e}_1) \\ f_{gca}(\vec{e}_2) &= \sum_{j \in N_r(\vec{e}_1)} \alpha_j * f_r(e_j)\end{aligned}$$

Where α_j is the attention value learned for the triple $\langle \vec{e}_1, \vec{r}, \vec{e}_j \rangle$

In a simple setting we can have $\alpha_j = \frac{1}{N_r}$ and learn

$$\vec{r} = f_{gca}(\vec{e}_2) - f_{gca}(\vec{e}_1) = f_{gca}(\vec{e}_3) - f_{gca}(\vec{e}_1)$$

With $\vec{e}_2 \neq \vec{e}_3$

However in a local context aware transform f_{lca} we have,

$$\begin{aligned}f_{lca}(\vec{e}_1) + \vec{r} &= f_{lca}(\vec{e}_2) \\ f_{lca}(\vec{e}_1) + \vec{r} &= f_{lca}(\vec{e}_3)\end{aligned}$$

From lemma 7.4 $\vec{e}_2 = \vec{e}_3$ and thus we can not have both $\langle \vec{e}_1, \vec{r}, \vec{e}_2 \rangle$ and $\langle \vec{e}_1, \vec{r}, \vec{e}_3 \rangle$ in \mathcal{T}_l

Thus $\mathcal{T}_{gca} \not\subseteq \mathcal{T}_{lca}$ and hence the proof \square

THEOREM 7.1. *Global context aware transform that is distinct for every relation for learning relation and entity embeddings in separate vector spaces is strictly more expressive than i) Learning the same embedding space ii) Using a common transform for every relation iii) Using local context only*

PROOF. Follows from lemma 7.1 to 7.6 \square

THEOREM 7.2. *There exists an optimum point for the ranking loss between the triplet vector additions of positive and negative triples, which can be traversed with decreasing loss at each step of the optimization from any point in the embedding space and as such an optimum optimization algorithm should be able to find such a point*

PROOF. Let us define the framework of the ranking loss as below. Consider a positive triple (e_1, r, e_2) and a negative triple (e_3, r, e_4) . The vector addition for the first triple would give $t_1 = \text{norm}(\vec{e}_1 + \vec{r} - \vec{e}_2)$ and for the second would give $t_2 = \text{norm}(\vec{e}_3 + \vec{r} - \vec{e}_4)$. The margin loss would then be defined as $\max(0, \text{margin} - (t_2 - t_1))$.

If we take the margin to be zero and ignore the term t_2 we get $\text{loss} = \max(0, t_1)$. Since the norm has to be ≥ 0 , $t_1 \geq 0$, hence, the loss becomes minimum when $t_1 = 0$. Removing the trivial case of all entity embeddings $= \vec{0}$, we define the loss space as follows. Without loss of generality we take the relation vectors to be fixed. For a triple $(\vec{e}_1, \vec{r}, \vec{e}_2)$ we take the difference $e_2 - e_1$. The loss for this triple then becomes $r - (e_2 - e_1)$. If we execute this for all triples we get

$$\begin{aligned}
Loss &= \sum_{i \in \mathcal{T}} \tilde{O} \left(r^i - (e_2^i - e_1^i) \right) \\
&= \sum_{i \in \mathcal{T}} \tilde{O} \left(r^i - e_2^i + e_1^i \right) \\
&= \text{Sum of all relation vectors} - \\
&\quad \text{Sum of difference of the entity vectors}
\end{aligned} \tag{26}$$

Now we define the point in vector space represented by $\sum_{i \in \mathcal{T}} (e_2^i - e_1^i)$ to be the current point in the optimization and plot the loss with respect to it which is the norm of the loss in the equation 26. Since there could be multiple configurations of the entity embeddings for each such point, we assume the loss to be an optimum loss given a configuration of entity embeddings i.e. the relation vectors could be so modified such that each difference term $r - (e_2 - e_1)$ is always greater than or equal to 0.

Let $R = \sum_{i \in \text{Triples}} r_i$ and $E = \sum_{i \in \text{Triples}} (e_2^i - e_1^i)$, then $Loss = |R - E|$ represents a cone. Now if we consider all the possible relation vector configurations and take all losses so that at each point in the vector space the minimum of each contribution is taken we get a piece-wise continuous function with conical regions and hyperbolic intersection of the cones as in figure 4.

In order for a path to exist between the start and a global optimum point under gradient descent, two conditions must hold

- (1) The function must be continuous
- (2) At no point in the function must there be a point such that there exists no point in its neighborhood with a lesser value

The derived function satisfies both the above properties and hence the proof. \square

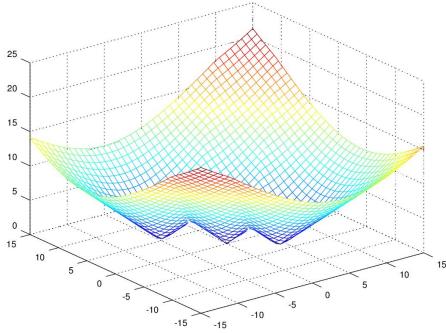

Figure 4: Loss function topology under the l_1 norm of the difference between the sum of relation vectors and entity vectors, demonstrating that convergence is possible from any starting point

The above theorem proves convergence when all entities are updated simultaneously. However this may not be possible in practice as the number of entities could be very large causing memory errors. We introduce a simple modification to train the entities batch wise i.e. to update via gradient descent only a sample of the entities thus reducing memory requirements. We shall see in the next theorem that this approach also converges.

THEOREM 7.3. *The entity vectors could be updated batch wise so as to monotonically reduce the loss till optimum is reached*

Algorithm 1: Algorithm for learning entity embeddings batch-wise using the margin ranking loss

Initialize the relation and entity embeddings randomly;

while not converged do

PROOF. • Select a subset of entities

$\{e_1, e_2 \dots e_n\} \subseteq E$

- Select the subset of 1-hop & 2-hop triples

$\mathcal{T}_{batch} \subseteq \mathcal{T} \mid e \in \tau \wedge \tau \in \mathcal{T}_{batch} \wedge e \in \{e_1, e_2 \dots e_n\}$

- Input \mathcal{T} to KGGAT-SEP model and compute a forward pass to get the new entity embeddings for the entities in the current batch keeping the other entity embeddings fixed.

- Compute the loss according to

$L(\Omega) = \sum_{\tau_{ht} \in \mathcal{T}^{pos}} \sum_{\tau'_{ht} \in \mathcal{T}^{neg}} \max\{d_{\tau_{ht}} - d_{\tau'_{ht}} + \gamma, 0\}$

- Back propagate using gradient descent to update $\{e_1, e_2 \dots e_n\} \subseteq E$

end

Consider a set of vectors $\vec{e}_1, \vec{e}_2 \dots \vec{e}_n$ and the resultant \vec{r} .

$$\vec{r} = \vec{e}_1 + \vec{e}_2 + \dots + \vec{e}_n$$

Also consider another set of entities $\vec{e}_1^{fi}, \vec{e}_2^{fi} \dots \vec{e}_n^{fi}$. The difference between \vec{r} and the sum of new set of vectors is

$$\begin{aligned}
\vec{d} &= \vec{r} - (\vec{e}_1^{fi} + \vec{e}_2^{fi} + \dots + \vec{e}_n^{fi}) \\
&= (\vec{e}_1 - \vec{e}_1^{fi}) + \text{fifi} + (\vec{e}_n - \vec{e}_n^{fi})
\end{aligned}$$

Now if we update a vector \vec{e}_i^{fi} to \vec{e}_i^{fi} to be closer to \vec{e}_i such that

$$|\vec{e}_i - \vec{e}_i^{fi}| >= |\vec{e}_i - \vec{e}_i^{fi}|$$

Then,

$$\begin{aligned}
|\vec{r} - (\vec{e}_1^{fi} + \dots + \vec{e}_i^{fi} + \dots + \vec{e}_n^{fi})| &>= \\
|\vec{r} - (\vec{e}_1^{fi} + \dots + \vec{e}_i^{fi} + \dots + \vec{e}_n^{fi})| &
\end{aligned}$$

Theorem 7.2 shows that such an update exists and performing it recursively for other entity vectors till optimum is possible under the given framework. \square