

CedrusDB: Persistent Key-Value Store with Memory-Mapped Lazy-Trie

Maofan Yin, Hongbo Zhang, Robbert van Renesse, Emin Gün Sirer
Cornell University

Abstract

As a result of RAM becoming cheaper, there has been a trend in key-value store design towards maintaining a fast in-memory index (such as a hash table) while logging user operations to disk, allowing high performance under failure-free conditions while still being able to recover from failures. This design, however, comes at the cost of long recovery times or expensive checkpoint operations. This paper presents a new in-memory index that is also storage-friendly. A “lazy-trie” is a variant of the hash-trie data structure that achieves near-optimal height, has practical storage overhead, and can be maintained on-disk with standard write-ahead logging.

We implemented CedrusDB, persistent key-value store based on a lazy-trie. The lazy-trie is kept on disk while made available in memory using standard memory-mapping. The lazy-trie organization in virtual memory allows CedrusDB to better leverage concurrent processing than other on-disk index schemes (LSMs, B⁺-trees). CedrusDB achieves comparable or superior performance to recent log-based in-memory key-value stores in mixed workloads while being able to recover quickly from failures.

1 Introduction

Persistent key-value stores have become an indispensable part of applications such as web servers [5], cloud storage [16, 52], machine learning [41], mobile apps [22], and blockchain infrastructures [46, 49]. There are two on-disk data structures that are often used for a general-purpose persistent key-value store: B⁺-trees and Log-Structured Merge Trees (LSMs). B⁺-trees have stable, predictable degradation as the data set grows large and supports fast read access, but they incur non-sequential small writes that sometimes get amplified in order to maintain balance. LSMs, on the other hand, are optimized for write-intensive workloads. They usually have high write-throughput as most of the writes are sequential and the resulting storage space is compact. An LSM does not have an explicit tree structure that organizes nodes as in B⁺-trees. Instead, the merge tree serves as a conceptual hierarchy that directs how to merge-sort user data. The amount of merge-sorted data gets amplified as the level goes deeper and thus may cause severe write amplification during log compaction. Compared to B⁺-trees, LSMs also have higher read amplification.

Both designs are intended for scenarios where the data set cannot fit in memory and the underlying secondary storage is much slower than memory. But servers and consumer devices have increasingly larger memories. Today, servers

may have tens to thousands of gigabytes of memory with a secondary storage using flash or non-volatile memory technology. As a result, more applications can have all or at least most of their data set fully reside in memory, and this has ignited interest in exploring new data structures that better utilize the characteristics of the abundant memory [13, 52] or even non-volatile main memory [27, 35]. At the same time, solid state devices (SSDs) may also require changes in data structures on secondary storage to take advantage of the much faster access times [30, 47].

Some recent key-value store designs have eschewed on-disk indexes altogether, favoring a fast in-memory index and an unordered solution for persistence such as logging updates sequentially or slab allocation [9, 29, 34, 36]. While such designs can perform very well in the failure-free case, crash recovery involves reading large sections if not all of the disk, leading to lengthy recovery times. Checkpointing can improve recovery time but comes at a considerable overhead during normal operation (§4.4). As an example, FASTER [9] is a recent work that keeps an in-memory hash table and logs all writes to the disk. While the design utilizes the disk bandwidth well for intensive in-place updates, a user has to invoke checkpoints manually to make the store persistent, where both checkpointing and recovery take substantial time due to the lack of an on-disk index.

As a result, applications that can fit their data in memory but also need persistence currently have to choose between stores that maintain relatively slow on-disk indexes and stores that have high failure recovery times. We therefore explore the design of key-value stores with the same persistence model as B⁺-tree- or LSM-based approaches but whose performance is competitive with a log-based approach to persistence.

To this end, we propose *lazy-trie*, a storage-friendly data structure. All nodes in a *lazy-trie* have the same number of children slots, simplifying maintenance. To bound the depth of the trie and probabilistically balance the load, user keys are hashed to index into the trie. To further reduce the depth of the trie and improve utilization, the *lazy-trie* uses a path compression technique similar to radix trees [40]. Finally, some small subtrees are collapsed into linked lists at leaves, greatly reducing storage overhead and read/write amplification.

We use the *lazy-trie* data structure to implement a memory-mapped, persistent key-value store, *CedrusDB*. It is able to achieve near-optimal dynamic tree height with practical storage overhead. Like LMDB [13], the implementation of

CedrusDB uses memory-mapping, but, unlike LMDB, CedrusDB does not require that all of the data set fit in available memory—CedrusDB implements its own page replacement and does not rely on the operating system kernel to do so. The lazy-trie organization in virtual memory allows CedrusDB to better leverage concurrency.

A shortcoming that CedrusDB shares with FASTER is that hashing makes support for range queries difficult. Fortunately, not all applications require support for range queries and there are various proprietary and open source key-value stores that do not support them [9, 16, 26, 31, 33]. Many applications use a key-value store to persist user data by keys. For example, a blockchain application stores data using keys that are already hashes. The Shadowfax distributed key-value store based on FASTER which is unordered and persistent like CedrusDB, serves 130 Mops/s/VM in the Microsoft Azure cloud [26]. There also exist practical techniques for supporting range queries on top of key-value stores that do not [43]. Another limitation of CedrusDB is that it does not perform as well as some of its competitors for write-only workloads or if the working set size is much larger than available memory.

This paper makes the following contributions:

- The lazy-trie data structure, which dynamically grows with near-optimal tree height, has a practical storage footprint, and allows for efficient concurrent access.
- The design and implementation of CedrusDB, a high-performance key-value store that uses the lazy-trie.
- An evaluation of CedrusDB for mixed workloads, comparing to the most important competitors.

2 The Lazy-Trie Data Structure

The design of CedrusDB is inspired by memory-mapped key-value stores like LMDB [13]. Instead of using B⁺-tree variants or other tree structures that require complex operations to move nodes across sibling subtrees for a logarithmic tree height, we propose *lazy-trie*, a trie-tree structure tailored for persistent storage. In this section, we describe the lazy-trie by progressively adding its crucial elements, along with a discussion of its properties and their implications for storage.

2.1 Hash-Trie for Persistent Storage

A *trie* is a tree structure that encodes all prefix paths of inserted key strings. Each key is treated as a sequence of consecutive fixed-width *characters*. A trie stores paths of edges representing character sequences, collapsing all shared prefix into a tree topology.

A *hash-trie* is a trie indexed by a hash. CedrusDB uses a strong (well-distributed) and fast hash function (§3) to map an arbitrary key string given by the user to a 256-bit hash. It then partitions the hash into equal-length characters. In the trie, a *tree node* consists of a character-indexed array of pointers to its child nodes and a pointer referring back

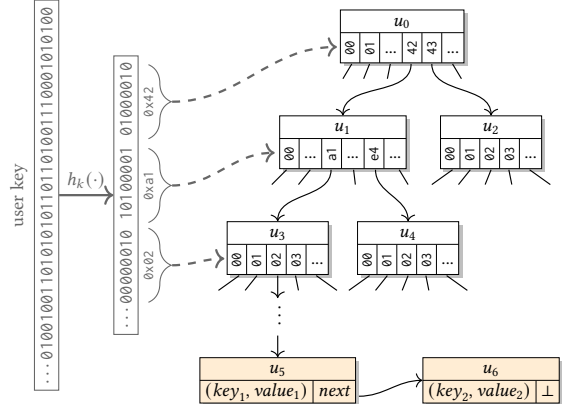

Figure 1. Structure of a hash-trie with chained leaf nodes.

to its parent node. We define the *height* of a given node to be the number of its ancestors. Each leaf node maintains a linked list of user key-value pairs. Figure 1 depicts the basic structure of a hash-trie, where the user key key_1 and key_2 in data node u_5 and u_6 have the same hash prefixed by $0x42a102$. The size of the hash should be chosen so that the probability of such collisions is small.

The insertion algorithm starts from the root node. It first visits the child indexed by the first character of the key hash, proceeds to the next child by the second character, and recursively walks down the trie until the entire key sequence is consumed. Child nodes are created as needed. At the leaf node, the algorithm adds a *data node* containing the original key-value data of the user to the linked list.

Lookup is similar to insertion. When reaching the leaf node, the linked list is scanned doing a full comparison using the original, unhashed user key to locate the value.

There are some similarities between the hash-trie and the B⁺-tree data structures. First, both are balanced, n-ary tree structures. In practice, a typical B⁺-tree has a branching factor of several hundreds. As we show later in the evaluation, a good choice for the branching factor for the hash-trie is hundreds of children per node as well. Second, both B⁺-trees and hash-tries only store user data at the leaves—intermediate nodes only contain metadata for indexing.

That being said, the structures have important differences. The height of a B⁺-tree is logarithmic in the number of keys. When inserting data, a B⁺-tree has to constantly adjust its topology across sibling subtrees to maintain tree balance. In a hash-trie, the path to the leaf node for a specific key is *static*: there is no reorganization of this path when other data is inserted or deleted. This significantly reduces the I/O cost of maintaining the internal index structure and simplifies concurrent access or modification to the tree, by sacrificing the support for range queries. Finally, all tree nodes of a hash-trie have an identical size and the same storage footprint, which simplifies the storage maintenance and reduces fragmentation. B⁺-tree nodes have a variable number of children, bounded by the branching factor.

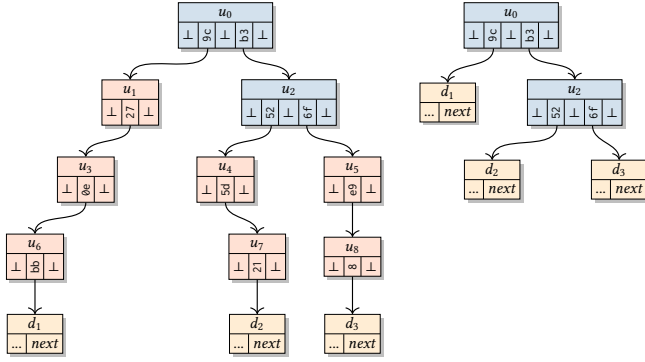

Figure 2. The tree structure without (left) and with (right) the path compression.

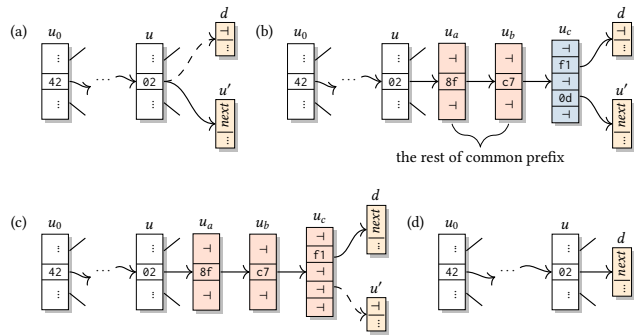

Figure 3. The bookkeeping operations required by lazy-trie. (a)(b) show a split operation, when a new data node d is inserted. (b)(c)(d) show a merge operation when the parent node u_c only has one child after the other child is removed.

A disadvantage of the hash-trie design is that operations always need to visit a fixed number of tree nodes even if the data store is small. Also, the utilization of child tables in tree nodes can be low, potentially resulting in significant write amplification. We next show, in two steps, how to improve upon the hash-trie structure to build a practical, dynamically grown *lazy-trie* with near-optimal height and small storage overhead by utilizing statistical properties of the hash function.

2.2 Path Compression

Let the branching factor be b . Then two keys have b^{-h} probability of sharing the same prefix of length h . The exponentially decreasing probability means that, as one descends into the tree, it becomes less likely to have forks in the tree. This led us to compress the suffix of paths in the hash-trie and only unroll the compressed path when necessary. Data nodes remain at the leaves, so the collision rate remains unchanged. Figure 2 illustrates the new design. Compared to radix trees, the difference is that we only compress the *suffixes* of paths—internal paths may still have nodes with only one child.

Whenever inserting a new node, we lazily create the minimum number of intermediate missing nodes just to distinguish data nodes with different hashes. During the insertion, we first follow the tree structure as usual. If we reach a data node that is supposed to be a tree node, then we insert a tree node, uncompressing the path (see Figure 3).

The lookup algorithm stays essentially the same: CedrusDB traverses the lazy-trie according to the key hash until it reaches a data node, then it scans through the data nodes. In the delete algorithm, when a data node is removed, a *merge* operation checks whether it is the only child of its parent node. If so, it collapses the non-forking path repeatedly until reaching an ancestor having more than one child.

Unlike insertion or deletion in other tree structures, which require complex recursive reorganization, there is at most one non-recursive split for each insertion and one non-recursive merge for each deletion. In a split, a simple path of intermediate nodes is created as a chain, while, in a merge, the longest non-forking path is collapsed into a direct parent reference. These operations only happen on a *single path* of insertion and deletion, so they do not interfere with any other siblings or their subtrees.

As a result, lazy-trie dynamically adjusts the tree height depending on how frequently the prefixes of inserted key hashes conflict. The hash function offers uniformly distributed key hashes regardless of the order of insertion, statistically balancing the tree with a height of approximately $\log_b n$, where n is the number of keys. Since the probability of a shared prefix decreases exponentially with the length of the prefix, in expectation there will be few missing intermediate nodes in a split operation.

2.3 Sluggish Splitting

The lazy-trie structure has an average path length that grows logarithmically with the number of keys (Figure 4, top, $s = 1$). However, due to the probabilistic nature, the paths for different keys can have significantly different lengths and the height of the trie (the maximum path length) can be significantly larger than the average path length. Moreover, the child tables in the leaf nodes tend to be mostly empty, leading to significant space underutilization because the majority of the space in a node is its child table (Figure 4, middle, $s = 1$). The problem is that the lazy-trie must guarantee that keys with different hashes cannot be in the same linked list.

To reduce variance in path lengths and improve utilization, we allow keys with different hashes to share the same linked list. We define *sluggishness* to be the maximum number of hash values allowed in a linked list of data nodes. The sluggishness bounds the worst-case scanning time in the linked list. A *sluggish lazy-trie* will only split the path when a linked list overflows. If so, the linked list will be replaced with a leaf node, and all data nodes in the linked list will be redistributed into the child table of the new leaf node. The redistribution is recursive and continues until the sluggishness

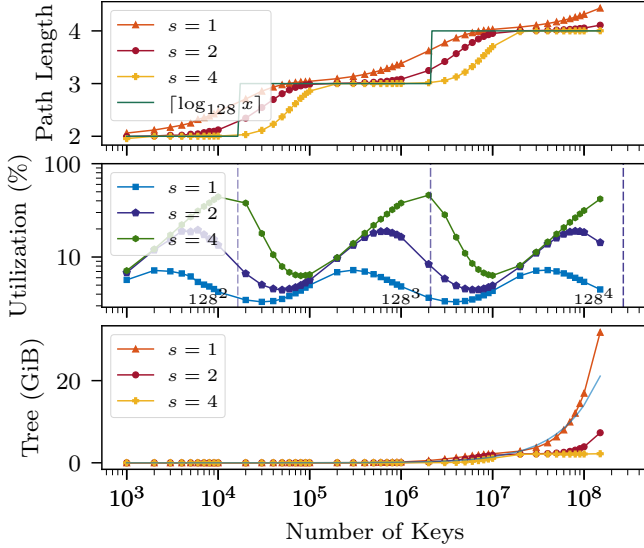

Figure 4. Average path length, child table utilization, and meta-data storage footprint for a 128-ary lazy-trie as a function of the number of keys, with different sluggishness values. The solid blue line in the bottom graph shows the user data footprint for 23-byte keys and 128-byte values.

constraint is met. Figure 5 shows an example of the steps in redistribution.

To demonstrate how sluggish splitting mitigates the problems of high path length variation and low utilization, Figure 4 shows the average path length and child table utilization as the data store grows in size for different levels of sluggishness s . The periodic change of utilization is due to the statistical growth of the tree height. The bottom graph shows the number of bytes used by tree nodes as a function of the number of keys. With a sluggishness $s = 4$, the storage overhead is significantly reduced compared to no sluggish splitting ($s = 1$).

We only consider sluggishness in splitting and otherwise retain the original merge algorithm. The only downside to not chaining leaves back into linked lists after deletion is that the tree metadata do not optimally shrink back after items are removed. However, left-over nodes will still be re-used when new items are inserted. We confirmed that the tree footprint does not increase over time by running random insertion/deletion (50% for each) experiments with 1 billion operations on an initial store of 100 million items.

3 System Design and Implementation

In this section, we show how a lazy-trie can be used to build CedrusDB, a high-performance key-value store. CedrusDB has been fully implemented in $\sim 8K$ lines of pure Rust. Rust is a modern systems programming language that provides statically checked memory- and thread-safety guarantees [4, 17, 48]. In addition to basic constructs offered by the standard library, it allows programmers to customize their building blocks with different safety guarantees [18]. For CedrusDB,

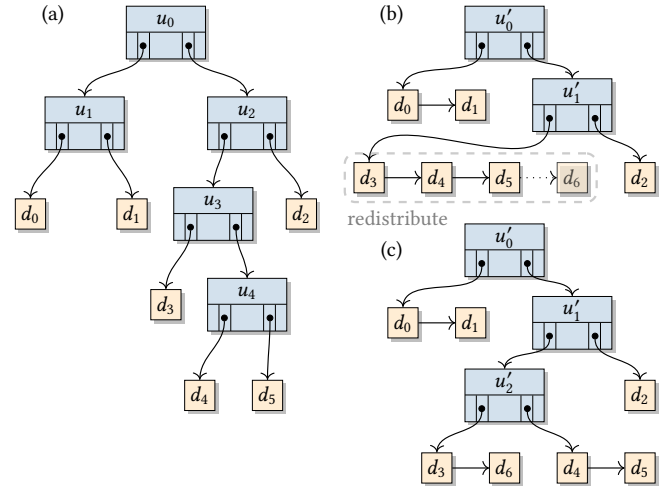

Figure 5. (a) a trie without sluggishness ($s = 1$). (b) in a sluggish lazy-trie, an insertion (d_6) can lead to overflowing the linked list of data nodes. (c) for a maximum sluggishness of 3, the data nodes are redistributed.

we explored how to separate the lazy-trie algorithm from the underlying storage management. We also made use of native functionalities of Linux, some of which may not be available on other operating systems, such as `io_submit` for kernel-based asynchronous IO (AIO).

3.1 Logical Spaces

In some key-value stores, like LMDB [13], the entire store is always mapped in memory and the maximum size has to be predetermined at its creation. CedrusDB supports a dynamically growing data set that may not all fit in memory. To support this, it has *logical spaces*, one for each type of objects. A logical space is a 64-bit four layer virtual address space. A *logical address* is a 64-bit unsigned integer subdivided into four parts: a segment number, a region number, a page number, and a page offset. CedrusDB associates a file with each segment. Each region is either fully mapped or unmapped. When mapped, it can be accessed like ordinary memory, that is, regions are memory-mapped that allow zero-copy read access. Figure 6 shows the organization of storage units with different granularities.

Objects cannot span across regions. Regions can only be accessed by mapping them, and thus the number of mapped regions is effectively the cache size, blurring the boundary between the “cache-based” approach, used by stores like LevelDB and RocksDB, and the “memory-based” approach by stores like LMDB and Memcached. Ideally, the performance is optimal when regions can remain mapped as long as they are in active use, which is the main focus of this paper.

To map regions, we use `mmap`. While in theory we could let the kernel keep track of dirty pages and write them back to the underlying segment files, we found that this solution, while simple, did not provide good performance even

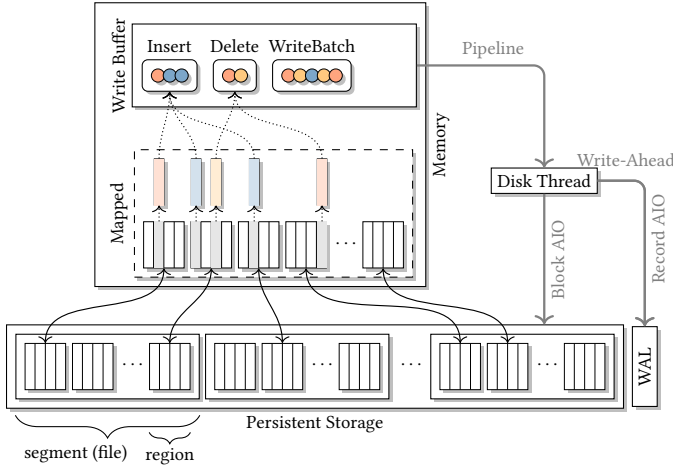

Figure 6. CedrusDB storage hierarchy with mapped memory and write buffer. The smallest rectangle represents a page.

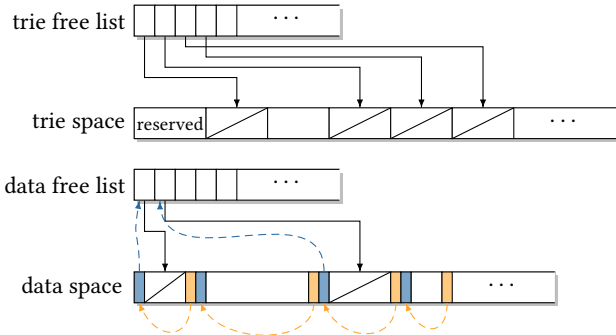

Figure 7. Four logical spaces used in CedrusDB.

when `madvise` is used. The kernel ends up writing the same, actively modified pages repeatedly, thus incurring prohibitively high write cost. Moreover, when the bounded kernel buffer of pending writes is full, the kernel slows down store instructions (such as `x86 mov`) made to the virtual memory space, resulting in performance that is hard to predict.

The storage architecture of CedrusDB is therefore hybrid. We map the regions in memory but keep track of our own write buffer for page writes. Doing so also benefits write-ahead logging (§ 3.4).

Logical spaces allow the lazy-trie algorithm to operate transparently as if the entire data structure is in memory. CedrusDB maintains four logical spaces:

1. *trie space*: tree nodes in use;
2. *trie free list*: a stack of pointers to unused tree nodes;
3. *data space*: data nodes in use;
4. *data free list*: an array of descriptors tracking the unused portion of data space.

Tree nodes have a fixed size, and thus the trie space contains an array of tree nodes. The trie free list contains a stack of indexes into the tree node array. To free a tree node, its

index is pushed onto the stack. To allocate a tree node, its index is popped from the stack.

In the data space, in-use and free data nodes of different sizes are stored continuously with a header at the front and a footer at the end. The footer of a data node is right before the header of the next data node and contains the size of the data node. It supports merging of two adjacent free data nodes (see below). Instead of maintaining a doubly-linked list of free data nodes like the free list in `glibc's malloc`, CedrusDB maintains a separate, unsorted array of *hole descriptors* for better locality and therefore I/O efficiency (see Figure 7). Each descriptor points to a free data node, while the header of a free data node points back to its descriptor.

CedrusDB adopts a *next-fit allocation policy* [23, 25], by indexing into the array of hole descriptors. An index points to the last visited descriptor and gets wrapped around when it hits the last item in the array. The index pointer, together with the trie root pointer and other tail pointers that indicate the boundary of logical spaces, are all stored within the first (reserved) 4KBytes page of the trie space, before the entire tree node array.

3.2 Memory Abstraction and Layout

To benefit from Rust’s memory-safety and thread-safety guarantees, we crafted our own memory-mapped object abstraction that fits in Rust’s idiom and thus utilizes its type checker. Rust does not come natively with a type-safe wrapper or primitive for memory-mapping. Although `nix` [42], a popular Rust library, provides related functions, they are exposed as Rust function signatures of the original POSIX interface in C. They are unsafe because the compiler makes normal assumptions about memory management and variable life-times without making accommodations for memory-mapped address space.

3.2.1 Space and Objects. The `MMappedSpace` struct is the core of implementing the logical space abstraction (§ 3.1). It can be created from file handles and exposes safe methods.

We use an opaque struct to represent a pointer into logical space so that either it can be reconstructed from persistent storage (like a pointer to an existing tree node) or allocated through `MMappedSpace`. The reason we need an abstraction for a pointer is two-fold. First, addresses in logical spaces do not directly correspond to virtual memory addresses even if the corresponding region is mapped. Second, using an integer indexing into logical space would be unsafe. Given a typed object pointer, `ObjPtr<T>`, it can dereference the pointer to the correspondingly typed object handle, `ObjRef<T>`. This allows manipulating the actual object typed `T` available in memory as if there is no memory-mapping. (It will auto-dereference to `&mut T`, which is an ordinary mutable access to a variable typed `T`.) The object handle is accessible throughout its lifetime by pinning the affected region in memory.

3.2.2 Tree Metadata. A lazy-trie tree node consists predominantly of a fixed-size array of pointers to its children. Two bitmasks indicate the validity and type of the pointer in a particular slot. To obtain child information, `chd_mask` is first examined to determine whether the slot contains a valid pointer. If so, `data_mask` specifies whether the pointer is to another tree node (`struct Node`) or a data node (`struct Data`). Both bitmasks are accessed using bitwise arithmetic. On x86-64 we use inline assembly with BMI quadword instructions such as `bsfq` and `bzhiq` for optimal performance.

We use the `#[repr(C)]` compiler directive to ensure a C-struct layout, guaranteeing that all memory-mapped objects can be correctly accessed even if the Rust compiler changes the default layout of `struct`. Unfortunately we cannot take advantage of the feature-rich Rust enum type. Thus, `ChdRaw` (union type for each child pointer) is hidden to other parts of the CedrusDB, which access the trie data structure through safe enum structs and methods.

3.2.3 User Data. We use Google’s HighwayHash [3] to hash keys. For each user key-value pair, we use an object of `Data` struct to hold the precomputed HighwayHash of the original arbitrary-length key in `hkey`, and size information for the original key and value in `key_size` and `val_size`. The actual user key and value are placed directly after the Rust structure. To support keys with colliding hashes and sluggish splitting, `Data` objects are chained together into a singly-linked list using the `next` pointer. We use `advise` [1] to request that the kernel pre-fetches the memory pages storing data objects.

3.3 Disk I/O

As described in Section 3.1 and shown in Figure 6, CedrusDB uses a separate write buffer to serialize all changes and schedule them as *block writes* to the physical storage device. Each modification made to the internal lazy-trie data structure first writes to memory.¹ The memory thus always reflects the latest changes. To update the underlying storage, the same write is also sent to a *disk thread* via a bounded buffer.

The changes generated to the in-memory data structures are short and frequent, which is not optimal for secondary storage. The disk thread therefore aggregates updates into blocks. The Linux ext4 filesystem has the same block size as the page size, so CedrusDB uses 4KBytes blocks.

While the lazy-trie data structure does not require log compaction such as used in LSMs and is arguably simpler to maintain than B⁺-trees, it suffers potentially from non-optimal locality and random writes when pointers need to be updated. To optimize storage updates, the CedrusDB disk thread uses Linux native Asynchronous I/O (AIO). Not to be confused with the POSIX AIO standard offered by `glibc` [44], Linux AIO performs concurrent writes if possible. We access

¹Due to limitations of `mmap`, we map the memory in copy-on-write mode even though we do not require that the original contents is saved.

AIO through `libaio`, a thin C ABI wrapper that is available on main-stream Linux distributions. AIO allows us to asynchronously manage reads and writes in a non-blocking style.

Because CedrusDB supports concurrent operations on the lazy-trie, it is possible that multiple user threads make changes to the same page (block). In CedrusDB it is the disk thread’s responsibility to obtain the consistent state of a block from a file if it is not already available in its cache, rather than copying the content from the mapped memory worked on by user threads, as there may be a data race. The disk thread can schedule such an infrequent block read while at the same time it can schedule other writes without being blocked.

3.4 Crash Recovery

CedrusDB utilizes write-ahead logging (WAL) to achieve atomicity and durability [39]. In the disk thread I/O pipeline, disk write records are first fed into a WAL worker. To better manage asynchronous I/O events, we implemented a library on top of `libaio` that manages I/O with *futures*. We then encapsulated the WAL logic into another library that schedules record writes via its own I/O manager handle. The disk thread pushes a vector of records to the WAL worker using the library, which immediately returns a future object that gets resolved when the record write is complete. The disk thread schedules block writes using its own I/O manager. Likewise, when the future gets resolved upon completion, the thread notifies the WAL worker that specific records can be pruned.

Similar to RocksDB, CedrusDB WAL records are grouped into fixed sized chunks. Each chunk contains a flag indicated if it is continued by the following one. CedrusDB operations may generate small writes to various locations in the logical space. Encoding high-level descriptions of operations directly as records does not work well for redos. Instead, CedrusDB encodes all actual low-level disk writes in each record. To avoid write amplification, it uses a compact format for records. A record is the concatenation of several subrecords, each of which encodes a single update made to a logical space.

3.5 Concurrent Access

The lazy-trie design does not require tree re-balancing operations, simplifying concurrent access. Because walks down the tree diverge exponentially fast, gains from concurrent access can be significant.

3.5.1 Tree-Walk Parallelism. Locating the leaf node does not change the trie structure, while insertion or deletion only makes changes starting from a leaf node. We assign a reader-writer lock to each tree node to control any access that goes through that node.

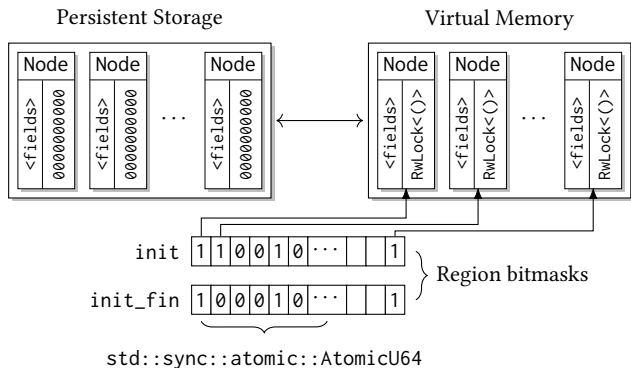

Figure 8. Implementation of trie node locks.

First consider lookup operations. For each node visited on the path to the leaf node, a thread acquires the read lock. Knowing that once the thread holds a read lock, no concurrent updates can happen to the node or any node below, it is safe for the thread to release the lock on the parent node, allowing concurrent updates to other parts of the trie.

In theory, insertions could also obtain read locks similar to lookups, until the thread needs to update a node. At that time, the thread would have to upgrade its read lock to a write lock. In practice, Rust does support an upgradable reader-writer lock, but it only allows at most one thread to hold an upgradable read lock at a time (while other threads may concurrently hold a regular read lock). The lock also supports a downgrade operation that converts an upgradable read lock into a regular read lock. We use it as follows: insertion proceeds as lookups but obtaining upgradable read locks. As soon as the thread determines that it will not need to update the node, it downgrades the lock before attempting to get an upgradable read lock on the next node down the path.

Deletion is more complex as it may remove a path that is being followed by other concurrent threads. CedrusDB assumes deletions are much less frequent than other operations. Based on this assumption, a thread performing a delete operation obtains write locks for the entire path, ruling out some concurrent access.

3.5.2 Fast Node Lock. The idiomatic way in Rust to add a lock to a type is `RwLock<T>`, a wrapper around type `T`. Because CedrusDB trie nodes are memory-mapped, we cannot use this facility directly. Instead, we maintain a `RwLock<>` within every trie node, using a negligible amount of space in the node (which is dominated by the table of child pointers), but need a way to initialize the locks after mapping their space from disk.

The lock objects are initialized on-the-fly as threads try to obtain them. We maintain two bitmaps with each region, each with one bit per trie node. For a region size of 16MBytes full of 256-child tree nodes, less than 2KBytes is needed for the bitmaps. `init_fin` indicates whether the corresponding lock is initialized. `init` indicates whether some thread is

in the process of initializing the lock. The bitmaps are implemented by a fixed-length array of 64-bit atomic variables so that query and modification can be performed atomically using bit operations (Figure 8). We hide this fast node lock facility from other parts of the system behind a safe interface.

3.5.3 Batched Writes. Like LevelDB, CedrusDB supports grouping several write operations (insert/delete) into a write batch. The atomicity of a write batch is guaranteed by write-ahead logging. Batches also need serializable isolation as they may be executed concurrently. Instead of acquiring a global mutex lock throughout the entire batch execution, CedrusDB implements a simple concurrency control method that divides a write batch execution into two phases. During the first phase, the global mutex is held, while the batch walks down the trie by alternating read locks and stops at the leaves where an insertion/deletion will happen. After the quick walk, the set of nodes whose write locks are required for all operations in the batch are recorded and deduplicated. Then the batch acquires the write locks and releases the global lock. With the node locks held, the thread resumes each operation in the batch and buffers all induced disk writes into a vector (`WriteBatch` in Figure 6). In addition to node locks, a thread may also acquire a lock to update the tail pointer of a logical space. Each tail pointer has its dedicated mutex lock. All tail pointer locks held by the thread will only be released at the end. Finally, the vector is submitted to the disk thread through the multi-producer, single-consumer write buffer, after which all locks are released. CedrusDB optimizes for single write operations without batching, as no extra concurrency control is needed in this case.

4 Evaluation

We evaluate the implementation of CedrusDB in order to answer the following questions:

- How does branching factor of a lazy-trie affect its performance? Which value of sluggishness should one choose? Is 256-bit practical enough for hashing? (§4.2.1, §4.2.2)
- What is the performance for various types of CedrusDB operations? Is it practical enough compared to other stores? (§4.2.3)
- How does performance degrade when user data cannot fit entirely in memory? What is the impact of the region size? (§4.2.4) What is the performance of data space allocator and what is the overall storage footprint? (§4.2.5)
- How well does CedrusDB perform under various kinds of realistic workloads? How well does it leverage concurrency? (§4.3)
- How does crash recovery in CedrusDB compare to other approaches? (§4.4)

4.1 Setup

Unless otherwise noted, we use Dell R340 servers to conduct our experiments. A server has a hexa-core Intel Xeon E-2176G 3.70GHz CPU with 64GB DDR4 memory. For the secondary storage medium, we use an Intel Optane 905P SSD with PCIe NVMe 3.0×4 interface. All evaluations are done on Ubuntu 18.04 LTS with a dedicated ext4 filesystem for persistent files. We allow asynchronous writes in all stores. For most experiments, the whole data set can fit into the memory.

We use FasterKV 1.8.4, LMDB 0.9.23 and RocksDB 6.1.2 as our baselines, representing a wide spectrum of persistent key-value store designs. In RocksDB, we enable the additional cache feature by setting the LRU cache to 40GB, the same amount used for CedrusDB memory-mapped regions. We disabled data compression to make comparison more fair. LMDB requires specifying the maximum data store size upon creation to preallocate the storage space—we also set it to the same amount of memory.

Our main target for comparison is FASTER [9], as it is the key-value store that is most closely related to CedrusDB. Like CedrusDB, FASTER uses key hashes for indexing and thus does not support range queries or sorted iteration. Despite this similarity, FASTER has a very different persistence model. FASTER divides its memory into two parts. One section of memory serves as a data cache for fast access, while the other part, the *HybridLog*, is used to log updates. By default, FASTER only writes its HybridLog to disk when the log can no longer be held in memory in its entirety. But even when the log is flushed, a user still needs to manually invoke the checkpoint function to make the logged changes persistent. In practice, one has to decide how frequently one should invoke FASTER’s checkpoint function, while other approaches persist their data continuously.

In our experiments, we made no FASTER checkpoints until the end of each run, resulting in the minimum I/O effort that FASTER undergoes to persist its state, but note that its in-memory index is not saved and is lost in the event of a failure. We made the initial hash table exactly large enough to contain the initial number of items and used the rest of the 40GB for HybridLog. To eliminate warmup-bias, we applied in-place updates until the memory part of the log was saturated and made a synchronous checkpoint to flush the leftover I/O induced by warmup operations before starting the workload. We used the C++ version of FASTER that is natively available on our Linux platform and should offer similar performance as the C# implementation [37]. FASTER also uses kernel-based AIO, so for fairness we set the same maximum I/O event limit as in CedrusDB.

For most microbenchmarks, we use 32-byte keys and 128-byte values. For macrobenchmarks, we evaluate CedrusDB using YCSB [11]. YCSB is written in Java whereas CedrusDB is in Rust and the other key-value stores are in C or C++.

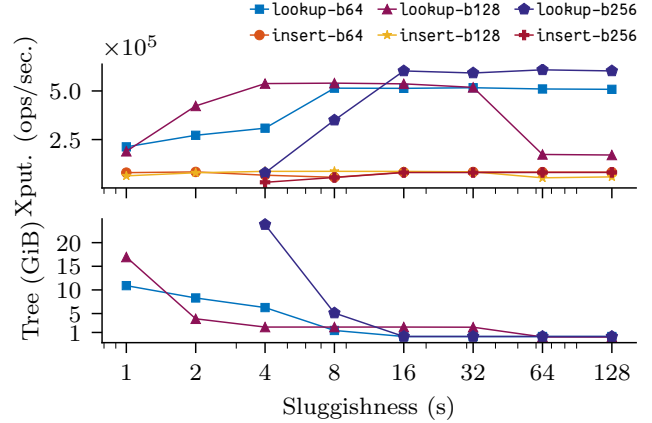

Figure 9. Lookup/insertion throughput (Xput.) and the tree footprint with different branching factors and sluggishness.

To avoid overhead caused by incompatible interfacing, we created a C binding for CedrusDB and invoke the APIs from a unified C++ test program dedicated to executing the YCSB workload. In the graphs with error bars, we run the same setup for 5 times and plot the mean in y-axis with standard deviation bars. For other graphs, the variation between runs is negligible. For each run, we populate the data store with a certain number of key-value items before running the test workload. The data store is reopened when the test starts. Finally, for multi-threaded experiments, we run a separate YCSB workload generator for each thread in such a way that a thread only handles keys that were preloaded or keys that were inserted by the thread itself.

4.2 Microbenchmarks

4.2.1 Branching Factor and Sluggishness. There are two parameters required to instantiate a lazy-trie: the tree branching factor and sluggishness, together determining the shape of the tree and its statistical characteristics. In Figure 9, we use branching factors 64, 128, and 256. We vary the sluggishness from 1 (no sluggishness) to 128. For each run, a data store of 100 million items is used to perform 10 million uniformly random lookups or insertions.

As discussed in Section 2.3, we expect that a larger branching factor will make the efficacy of sluggishness more pronounced as having more slots in the child table leads to higher storage overhead and amplification. Indeed, we see that for a branching factor of 256, sluggishness significantly improves performance. Data points for $s < 4$ are not shown in the graphs because those runs end up with a tree footprint that exceeds the memory of our platform. Compared to (32+128)-byte key-values, each tree node with 256 children slots takes up around 2KBytes of space. By having more sluggishness, storage overhead is greatly mitigated and both lookup and insertion performance ramp up to reach or surpass those of other branching factors. When increasing sluggishness from 4 to 16, the memory footprint gets cut down from more than 23GBytes to 144MBytes. The performance

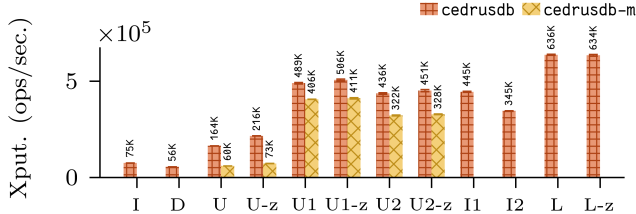

Figure 10. Microbenchmark with 10^8 items and 5×10^7 operations (single-threaded).

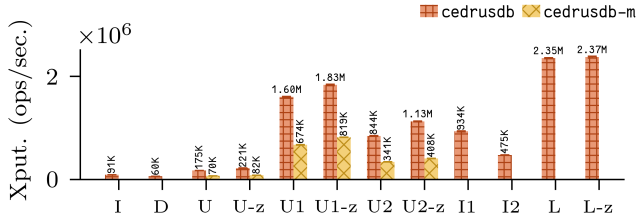

Figure 11. Concurrent microbenchmark with 10^8 items and 5×10^7 operations (4 threads).

drop of b128 with excessive sluggishness is due to the periodic change of node utilization (Figure 4, middle). Given our store size (10^8 items), this leads to excessively long linked lists. Thus one should choose the least sluggishness that achieves the desired footprint.

When using a branching factor of 64, each tree node only takes around 512 bytes and it requires a lower sluggishness for comparable performance. On the other hand, because the data store can be fully cached in memory, the choice of branching factor does not significantly affect the maximum performance due to the low cost of memory access. To reduce the tree height and have the best lookup performance, we use a branching factor of 256 with sluggishness of 16 as a practical choice for all subsequent experiments.

4.2.2 Hash Length. In the prior experiments, we used 256-bit HighwayHash to hash the keys. HighwayHash also provides 64- and 128-bit hashing. While generating a shorter hash is faster, it increases the collision rate, amplifying the cost of scanning the linked list of data nodes. We experimented with all three hash lengths but found no difference in performance. We use 256-bit hashes for the remainder of the evaluation.

4.2.3 Throughput. We examine the performance of individual types of operations with a single client thread. We populate the store with 100 million items and conduct 50 million reads or writes. Figure 10 shows that CedrusDB performs uniformly random (L) or Zipfian (L-z) lookups much faster than pure insertions (I), deletions (D) and updates (U). CedrusDB has two kinds of updates: (i) *in-place updates* (as used in FASTER/LMDB by default) when the new value can fit into the footprint of the current one, and (ii) *emulated updates* that remove the current values and insert the new ones. We instrumented CedrusDB so we could test both individually. `cedrusdb` shows in-place update performance and `cedrusdb-m` shows the performance when all updates are

treated as deletions followed by insertions. Unsurprisingly, in-place updates are fastest since they do not alter the tree topology.

Although we used the fastest async channel implementation available for Rust, we still noticed insertions are bottlenecked by our write buffer as the throughput of insertions would have been doubled ($\sim 180K$) had we changed the order and granularity of writes (but atomicity would no longer be guaranteed). We observed the same bottleneck in Figure 9.

To see the impact of writes to the overall performance when they are mixed together with reads, we tested it with 10% (U1*, I1) and 20% (U2*, I2) writes. CedrusDB still benefits from fast reads in these workloads.

As for concurrent access (Figure 11), in a 4-thread setup, mixed writes also preserve some degree of scalability from reads. The performance of deletions is the lowest because they require frequent access to the data space allocator and also change the tree topology.

4.2.4 Elastic Memory and Regions. While CedrusDB is optimized for the case that the entire data store fits within a given memory budget, the region-based mapping design of CedrusDB allows a larger data store. We evaluate how performance degrades as CedrusDB runs out of the memory budget. We started with a baseline experiment using 100 million data items that did not have a memory budget, so the data store could utilize all the memory. We recorded the maximum number of regions and used that as the memory budget. We then experimented with 0%–25% of additional user data to see how performance changes.

Figure 12 shows lookup performance for region sizes ranging from 64KBytes (lookup16, 16-bit) to 16MBytes (lookup24, 24-bit). The figure that shows having larger region size results in better performance when all data fit in memory, but degrades quickly when data exceeds the memory budget. When the whole data set fits in memory (0%), small region sizes hurt performance because there is more overhead for managing regions and their mapping. For large region sizes, the coarse granularity of mappings make it more likely that cold and hot items are collocated in the same region, resulting in increased swapping. Figure 13 shows the results for write operations. In this figure, each line is normalized to the full memory budget performance. We see that faster operations like updates degrade more than slower ones like deletions, due to the high penalty of swapping compared to in-memory operations. So while CedrusDB will continue to operate well when running out of the given memory budget rather than simply give up, it is important to adjust the memory budget accordingly.

4.2.5 Variable-Length Values and Fragmentation. So far (and as is common practice in many key-value store evaluations), we used the same length for all values. For CedrusDB, this means that the data space allocator only needs to take one step to find the next-fit location that was previously

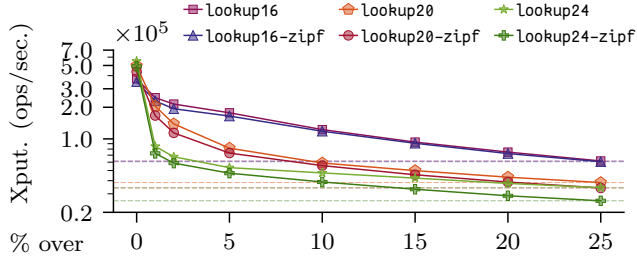

Figure 12. Read performance for different region sizes, with user data beyond the memory budget.

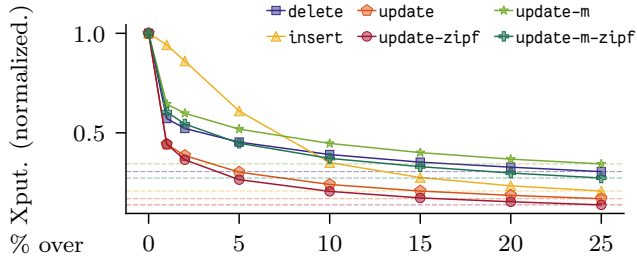

Figure 13. Normalized write performance with user data beyond the memory budget.

freed to recycle. When allowing in-place updates, the allocator is not even engaged. Thus, to thoroughly examine our design and effectively evaluate the allocator, we generated a workload that mixes 128/256/1024 values uniformly. We first populated the store with 10 million items. To have each value updated many times on average, we ran 100 million operations with the mixed workload (M), changing the value of each key ~ 5 times throughout the entire run.

For the next-fit allocator, scanning through the entire free list before giving up is too expensive in practice. Instead of making sure to recycle a freed object whenever possible, allowing some slack in using the free list does not cause significant fragmentation. Therefore we limit the maximum number of steps in scanning the free list during an allocation.

In the right subgraph of Figure 14, we vary the scan step limit (Max. Scan) and show the change of the amplification factor (Disk Amp.) and the ratio of reusing freed space in an allocation (Recycled). The disk amplification factor is the final disk usage divided by the initial one. It is greater than 1 for all stores due to fragmentation. Once the limit exceeds 100 there is little difference compared to having no limit. Moreover, as shown in the left subgraph of Figure 14, we believe the fragmentation ratio of CedrusDB is reasonable compared to other key-value stores.

4.3 Macrobenchmarks

In this section, we evaluate CedrusDB using YCSB [11] workloads with Zipfian distributions. We used a region size of 16 MBytes for all experiments.

4.3.1 Single-Threaded Performance. Figure 15 shows single-threaded throughput for different read/write ratios using 128-byte values; Figure 16 shows the same for 1KByte values. The data store is populated with 100 million keys.

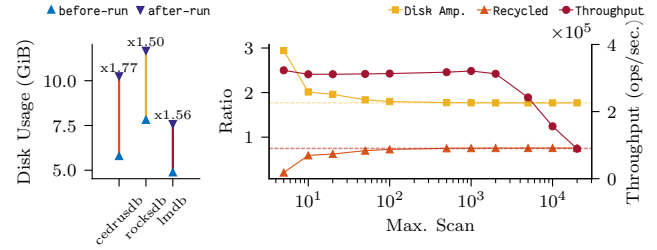

Figure 14. Data space allocator statistics and storage amplification due to fragmentation.

Two types of write operations are considered: updating the value of an existing key and inserting a value with a non-existing key. Although both use the same API, they trigger different code paths (as demonstrated in our microbenchmarks). The upper graph shows results from runs where all writes are updates whereas the lower shows insertions; in the rightmost bars, all operations are lookups. CedrusDB achieves performance comparable to or better than LMDB and RocksDB in write-intensive mixed workloads. It outperforms others in read-intensive cases, with the exception that LMDB is slightly faster in these cases and noticeably faster in pure lookups, when using 128-byte values.

In contrast, FASTER, which does not maintain an on-disk index, performs better with more updates. Changes are appended to an in-memory log that is eventually flushed to disk when memory runs low. In the absence of reads, this scheme is bottlenecked only by disk bandwidth. However, if there are read operations, FASTER performance suffers from not having an on-disk index. FASTER is optimized for in-place updates, which get translated into modifications inside the in-memory log. Its insertion performance reveals more of the performance impact by writes as shown at the bottom of the graph.

To evaluate performance when values have varying sizes, we generated two workloads. In workload A, for each key, the value is 128, 256 or 1024 bytes chosen uniformly at random. This illustrates a scenario in which the key-value store has items with only a few but very different sizes. On the other hand, workload B considers a scenario where most values have a similar size. The values are chosen between 128 and 256 bytes with Zipfian distribution. Both workloads are run using 100 million mixed lookup/update operations given 10 million initial items. CedrusDB achieves better performance than others for read-intensive cases in both workloads (Figure 18), while it degrades faster with more updates. This is because variable-length values may not be updated in-place and thus trigger intensive access to the data space allocator. On the other hand, even in the most write-intensive case the increase of disk usage caused by fragmentation of CedrusDB remains reasonable, as shown at the bottom of Figure 18. We did not evaluate the performance of FASTER for this workload as the C++ implementation (unlike its C# version) does not support variable-length values.

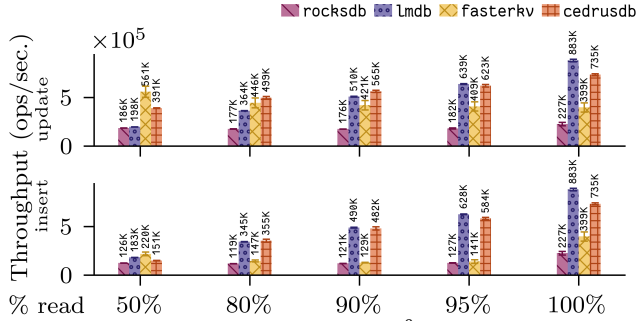

Figure 15. YCSB evaluation with 10^8 128-byte values and operations (single-threaded).

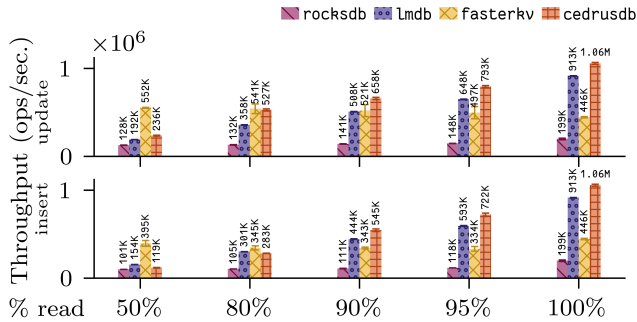

Figure 16. YCSB evaluation with 10^7 1024-byte values and operations (single-threaded).

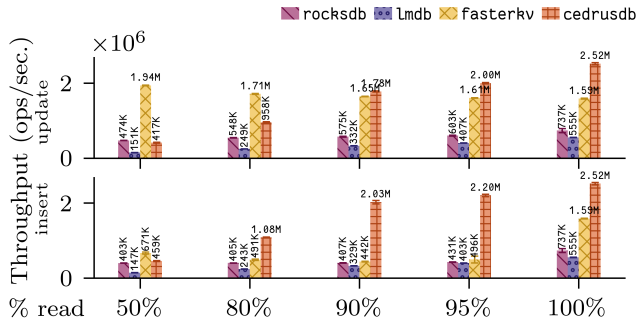

Figure 17. YCSB evaluation with 10^8 128-byte values and operations (4 threads).

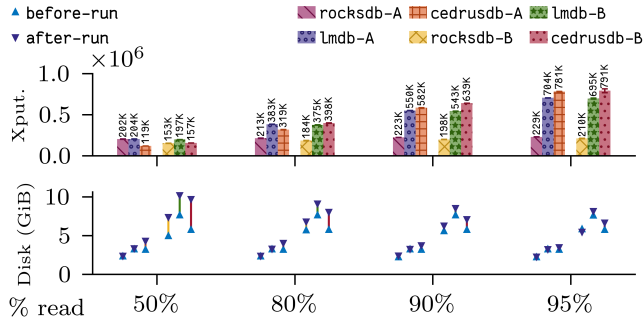

Figure 18. YCSB variable-length throughput (Xput.) with 128/256/1024 (*-A) or 128-256 (*-B) byte values (single-threaded).

4.3.2 Concurrent Performance. Next we evaluate multi-threaded performance. Both LMDB and RocksDB have specific optimizations to take advantage of concurrency [12, 21] whereas FASTER uses atomic operations on its in-memory

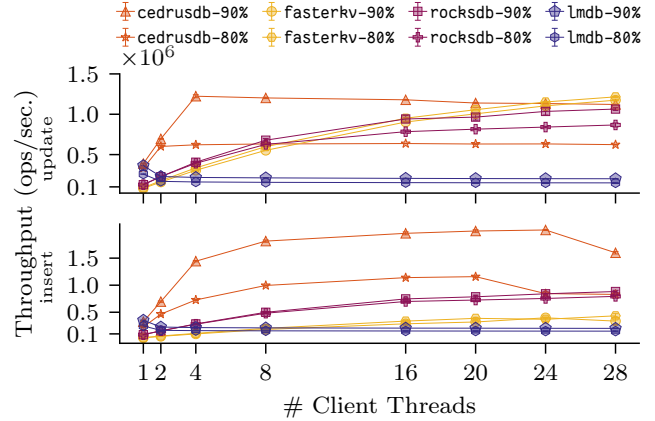

Figure 19. Concurrent YCSB evaluation with 10^8 128-byte values and operations (AWS NVMe SSD).

hash table. Our lazy-trie requires no reorganization when keys are inserted or deleted, simplifying concurrent access, which could be viewed in a way as having small “hash tables” with some tree hierarchy. Figure 17 shows the aggregated throughput when 4 client threads access the data store at the same time. CedrusDB outperforms others in read-intensive workloads. FASTER performs best under intensive updates, but the performance suffers when the writes are insertions.

To test the scalability in the number of threads, we conducted the same experiments on an Amazon AWS r5d. 8x1large instance. We used one NVMe SSD and run 80%–90% read and 20%–10% update/insert workloads with a varying number of client threads.² Figure 19 shows that CedrusDB scales well until it hits the shared lock bottleneck at around 8 threads. CedrusDB update performance plateaus much earlier than insertions because Zipfian updates induce contention of frequently accessed items (hashing does not prevent this because the same key always corresponds to the same hash), whereas insertions create new items and benefit more from non-overlapping tree walks. The Rust MPSC (Multi-Producer, Single-Consumer) write-buffer library limits insertion performance when there are more than 20 threads. Nevertheless, the read-intensive (90% read) update throughput of CedrusDB is still 1.05–3.07x that of RocksDB, 1.07–5.74x the throughput of LMDB, and 0.95–4.79x the throughput of FASTER. For insert, CedrusDB is either competitive or superior to all others. While the performance of FASTER is inferior to that of CedrusDB for various workloads, its in-memory, lock-free hash table implementation causes FASTER to plateau much later than CedrusDB in update workloads.

4.4 Crash Recovery

In recent years, various projects have proposed boosting the performance of key-value stores by eschewing the on-disk index and emphasizing a fast in-memory index. The

²FASTER experienced consistency issues when running with 24–28 threads, when some existing keys were reported missing. We went ahead and collected the measurements regardless.

| | Persistence | Indexing | Recovery (sec.) | Checkpoint (sec.) | Throughput (Kops/sec.) |
|----------|----------------------|----------|---------------------|-------------------|------------------------------|
| CedrusDB | always, disk-indexed | hashed | 0.645 | - | 391 |
| FASTER | manual, log-based | hashed | 28.16 | 19.38 | 446 (disk) / 1125 (volatile) |
| LMDB | always, disk-indexed | sorted | 0.003 | - | 198 |
| RocksDB | always, disk-indexed | sorted | 0.267 | - | 186 |
| Masstree | always, log-based | sorted | 31.8 per 10^8 ops | $\approx 33.5^*$ | 1123 |
| KVell | always, slab-based | sorted | 91.9 | - | 410 |

Table 1. Key-value stores with different schemes. YCSB (50% updates), Zipfian, 128-byte values and 10^8 items. Throughput shows the normal operation performance where no checkpoint is made. * Extrapolated value—see text.

potential price paid is increased recovery time. Similar to LMDB and RocksDB, CedrusDB takes a more traditional approach by having an up-to-date on-disk index. In this section, we consider the performance trade-offs of the two approaches. We used CedrusDB, LMDB, and RocksDB as representatives of key-value stores that maintain an up-to-date on-disk index, and FASTER, Masstree [34], KVell [29] as representatives of the alternative approach.

We ran the following experiment with each key-value store. After populating the store with 100 million keys, we ran 100 million 50% update YCSB workload operations before killing the program. We then measured the recovery time.

As shown in Table 1, the sorted on-disk index of RocksDB comes at the expense of throughput compared to CedrusDB whose index with hashed keys does not support range queries. RocksDB has faster recovery time because its WAL records high-level operations, whereas CedrusDB logs the induced low-level writes. Nonetheless, the recovery time for both is short and mostly dependent on the implementation and configuration and not affected by store size or total number of writes. LMDB uses *shadow paging*, a copy-on-write technique to persist data. Without the need for WAL, it takes negligible time to recover. Next we compare with FASTER, Masstree and KVell.

FASTER. As recommended by the developers [38], we made checkpoints with the “fold-over” setup, which result in lightweight, incremental checkpoints. Each fold-over checkpoint blocked on-going operations for around 19 seconds, and recovery took 28 seconds. The overhead of the checkpoint is partially due to saving the in-memory hash table, a limitation of using flat structure that is not friendly to persistent storage. For its normal performance, we used the same hash function as in CedrusDB and also tried the “volatile” case where there is no warm-up phase to saturate the memory part of HybridLog so there are no disk writes. In this case, we found the performance similar to Masstree.

Masstree. Masstree [34] maintains a trie-like concatenation of B^+ -trees in memory and logs all writes to the disk. This enables high throughput as no on-disk index is maintained. On the other hand, during a recovery the log has to be replayed to restore the in-memory index. In the experiment we performed, it took around 31.8 seconds for playing back

around 50 million write operations (50% of operations are writes).

To mitigate this and also to recycle the log storage, Masstree supports checkpoints that serve as new initial states for replay. We took snapshots of the store at 1 million (0.29 seconds) to 10 million (3.35 seconds) items and confirmed linear growth of the checkpointing time. Unfortunately, the snapshot with 100 million items was not successful with the Masstree code, so the number in Table 1 is extrapolated.

KVell. Instead of using an append-only log, KVell [29] uses slabs to preallocate space for items. We used its most recent GitHub code to run the experiment. The code currently does not support YCSB keys (the paper used 8-byte random integer keys for YCSB instead). We generated 23-byte keys with random bytes using the same distribution to best approximate the YCSB workload. KVell’s recovery takes 91.9 seconds regardless of the number of operations. This time depends only on the size of the data store. KVell is currently unable to perform a crash recovery for a workload with a mix of insert and delete operations.

5 Related Work

Various prior systems have looked into better leveraging available memory to speed up performance of key-value stores. SILT [30] has a pipeline of three data structures to improve memory-efficiency and write-friendliness. LMDB [13] is a popular open-source key-value store that leverages a memory-mapped, copy-on-write B^+ -tree. CedrusDB’s usage of memory-mapped storage is inspired by LMDB. As discussed in §4.4, there are also persistent key-value stores that only keep a fast, concurrent hash table or other indexing data structures in-memory and pipe all writes directly into append-only logs or pre-allocated slabs [9, 29, 34, 36]. Such architectures suffer from significant recovery/checkpoint overhead.

There has been extensive work to reduce write-amplification in LSM-based persistent key-value stores. RocksDB [8, 19] is a fork of LevelDB improved by developers at Facebook. It provides more features such as multi-threaded compaction and support for transactions. Inspired by skip lists and based on HyperLevelDB [20], PebblesDB [45] proposes the Fragmented LSM data structure, carefully choosing the SSTs during compaction to reduce amplification. LSM-trie [50] uses

a static hash-trie merge structure that keeps reorganizing data for more efficient compaction. SuRF [51] uses an LSM design with a trie-based filter to optimize range queries. Accordion [7] improves the memory organization for LSM. Monkey [14] reduces the lookup cost for LSM by allocating memory to filter across different levels, minimizing the number of false positives. Dostoevsky [15] introduces lazy-leveling to remove superfluous merging. mLSM [46] is tailored for blockchain applications and significantly improves the performance of the Ethereum storage subsystem.

There are also recent proposals to combine LSM and B⁺-tree designs. Jungle [2] reduces update cost without sacrificing lookup cost in LSM using a B⁺-tree. SLM-DB [24] assumes persistent memory hardware. It uses a B⁺-tree for indexing and stages insertions to LSM.

Existing storage data structures have evolved in response to changes in hardware. wB⁺-tree [10] reduces transaction logging overhead for a B⁺-tree in non-volatile main memory. LB⁺-tree [32] optimizes the index performance using 3DX-Point persistent memory. S3 [52] uses an in-memory skip-list index for a customized version of RocksDB in Alibaba Cloud. RECIPE [27] offers a principled way to convert concurrent indexes on DRAM to the one on persistent-memory with crash-consistency.

Like CedrusDB, other systems have embraced the trie for in-memory indexes. ART [28] uses a radix tree, also compresses the non-diverging paths. HOT [6] uses an adaptive number of children for each node. Compared to these in-memory indexes, there are several major differences: (1) CedrusDB is designed to be persistent and has an optimized lazy-trie for an on-disk index; (2) To ensure near-optimal tree height like a B⁺-tree, instead of directly using key strings to index the trie, lazy-trie uses fixed-length hashes, having different statistical properties; (3) In addition to path compression, lazy-trie employs sluggish splitting to reduce variance in tree height, making the tree storage footprint practical and even lower than that for a B⁺-tree.

6 Conclusion

This paper explored the idea of an in-memory index that is also storage-friendly, allowing both fast in-memory access and fast failure recovery. We designed the lazy-trie data structure and implemented CedrusDB to this end. CedrusDB represents a new trade-off between fast access and fast recovery. Potential future work directions include further optimizing performance, for example by removing bottlenecks in shared locks and the Rust write buffer. Furthermore, to increase applicability, we are also interested in designing a sorted data structure that could support range queries.

References

[1] madvise(2) - Linux manual page. <http://man7.org/linux/man-pages/man2/madvise.2.html>. Accessed: 2020-04-15.

[2] AHN, J., QADER, M. A., KANG, W., NGUYEN, H., ZHANG, G., AND BENDROMDHANE, S. Jungle: Towards dynamically adjustable key-value store by combining LSM-tree and copy-on-write B⁺-tree. In *11th USENIX Workshop on Hot Topics in Storage and File Systems, HotStorage 2019, Renton, WA, USA, July 8-9, 2019* (2019), D. Peek and G. Yadgar, Eds., USENIX Association.

[3] ALAKUIJALA, J., COX, B., AND WASSENBERG, J. Fast keyed hash/pseudo-random function using SIMD multiply and permute, 2016.

[4] ANDERSON, B., BERGSTROM, L., GOREGAOKAR, M., MATTHEWS, J., MCALLISTER, K., MOFFITT, J., AND SAPIN, S. Engineering the servo web browser engine using rust. In *Proceedings of the 38th International Conference on Software Engineering, ICSE 2016, Austin, TX, USA, May 14-22, 2016 - Companion Volume* (2016), L. K. Dillon, W. Visser, and L. Williams, Eds., ACM, pp. 81–89.

[5] BADAM, A., PARK, K., PAI, V. S., AND PETERSON, L. L. Hashcache: Cache storage for the next billion. In *Proceedings of the 6th USENIX Symposium on Networked Systems Design and Implementation, NSDI 2009, April 22-24, 2009, Boston, MA, USA* (2009), J. Rexford and E. G. Sirer, Eds., USENIX Association, pp. 123–136.

[6] BINNA, R., ZANGERLE, E., PICHL, M., SPECHT, G., AND LEIS, V. HOT: A height optimized trie index for main-memory database systems. In *Proceedings of the 2018 International Conference on Management of Data, SIGMOD Conference 2018, Houston, TX, USA, June 10-15, 2018* (2018), G. Das, C. M. Jermaine, and P. A. Bernstein, Eds., ACM, pp. 521–534.

[7] BORTNIKOV, E., BRAGINSKY, A., HILLEL, E., KEIDAR, I., AND SHEFFI, G. Accordion: Better memory organization for LSM key-value stores. *PVLDB* 11, 12 (2018), 1863–1875.

[8] CAO, Z., DONG, S., VEMURI, S., AND DU, D. H. Characterizing, modeling, and benchmarking RocksDB key-value workloads at Facebook. In *18th USENIX Conference on File and Storage Technologies (FAST 20)* (Santa Clara, CA, Feb. 2020), USENIX Association, pp. 209–223.

[9] CHANDRAMOULI, B., PRASAAD, G., KOSSMANN, D., LEVANDOSKI, J. J., HUNTER, J., AND BARNETT, M. FASTER: A concurrent key-value store with in-place updates. In *Proceedings of the 2018 International Conference on Management of Data, SIGMOD Conference 2018, Houston, TX, USA, June 10-15, 2018* (2018), G. Das, C. M. Jermaine, and P. A. Bernstein, Eds., ACM, pp. 275–290.

[10] CHEN, S., AND JIN, Q. Persistent B⁺-trees in non-volatile main memory. *PVLDB* 8, 7 (2015), 786–797.

[11] COOPER, B. F., SILBERSTEIN, A., TAM, E., RAMAKRISHNAN, R., AND SEARS, R. Benchmarking cloud serving systems with YCSB. In *Proceedings of the 1st ACM Symposium on Cloud Computing, SoCC 2010, Indianapolis, Indiana, USA, June 10-11, 2010* (2010), J. M. Hellerstein, S. Chaudhuri, and M. Rosenblum, Eds., ACM, pp. 143–154.

[12] CORPORATION, S. LMDb: Lightning Memory-Mapped Database Manager. <http://www.lmdb.tech/doc/>. Accessed: 2020-05-16.

[13] CORPORATION, S. Symas lightning memory-mapped database. <https://symas.com/lmdb/>. Accessed: 2020-04-15.

[14] DAYAN, N., ATHANASSOULIS, M., AND IDREOS, S. Monkey: Optimal navigable key-value store. In *Proceedings of the 2017 ACM International Conference on Management of Data, SIGMOD Conference 2017, Chicago, IL, USA, May 14-19, 2017* (2017), S. Salihoglu, W. Zhou, R. Chirkova, J. Yang, and D. Suciu, Eds., ACM, pp. 79–94.

[15] DAYAN, N., AND IDREOS, S. Dostoevsky: Better space-time trade-offs for LSM-tree based key-value stores via adaptive removal of superfluous merging. In *Proceedings of the 2018 International Conference on Management of Data, SIGMOD Conference 2018, Houston, TX, USA, June 10-15, 2018* (2018), G. Das, C. M. Jermaine, and P. A. Bernstein, Eds., ACM, pp. 505–520.

- [16] DECANDIA, G., HASTORUN, D., JAMPANI, M., KAKULAPATI, G., LAKSHMAN, A., PILCHIN, A., SIVASUBRAMANIAN, S., VOSSHALL, P., AND VOGELS, W. Dynamo: Amazon’s highly available key-value store. In *Proceedings of the 21st ACM Symposium on Operating Systems Principles 2007, SOSP 2007, Stevenson, Washington, USA, October 14-17, 2007* (2007), T. C. Bressoud and M. F. Kaashoek, Eds., ACM, pp. 205–220.
- [17] DEVELOPERS, R. O. Redox - your next(gen) OS. <https://www.redox-os.org/>. Accessed: 2020-04-15.
- [18] DEVELOPERS, T. R. P. The Rustonomicon: the dark arts of advanced and unsafe Rust programming. <https://doc.rust-lang.org/stable/nomicon/>. Accessed: 2020-04-15.
- [19] DONG, S., CALLAGHAN, M., GALANIS, L., BORTHAKUR, D., SAVOR, T., AND STRUM, M. Optimizing space amplification in RocksDB. In *CIDR 2017, 8th Biennial Conference on Innovative Data Systems Research, Chaminade, CA, USA, January 8-11, 2017, Online Proceedings* (2017), www.cidrdb.org.
- [20] ESCRIVA, R. Inside HyperLevelDB. <https://hackingdistributed.com/2013/06/17/hyperleveldb/>. Accessed: 2020-04-20.
- [21] FACEBOOK. Memtable - facebook/rocksdb wiki. <https://github.com/facebook/rocksdb/wiki/MemTable#concurrent-insert>. Accessed: 2020-05-16.
- [22] HACHICHA, N. SnappyDB: a fast and lightweight key/value database library for Android. <https://www.snappydb.com/>. Accessed: 2020-04-15.
- [23] JOHNSTONE, M. S., AND WILSON, P. R. The memory fragmentation problem: Solved? *ACM Sigplan Notices* 34, 3 (1998), 26–36.
- [24] KAIYRAKHMET, O., LEE, S., NAM, B., NOH, S. H., AND CHOI, Y. SLM-DB: single-level key-value store with persistent memory. In *17th USENIX Conference on File and Storage Technologies, FAST 2019, Boston, MA, February 25-28, 2019* (2019), A. Merchant and H. Weatherspoon, Eds., USENIX Association, pp. 191–205.
- [25] KNUTH, D. E. *The Art of Computer Programming, Volume 1: Fundamental Algorithms*, vol. 1. Pearson Education, 1997.
- [26] KULKARNI, C., CHANDRAMOULI, B., AND STUTSMAN, R. Achieving high throughput and elasticity in a larger-than-memory store. In *Proc. VLDB Endow. Volume 14, Issue 8, 2021 (to appear)*.
- [27] LEE, S. K., MOHAN, J., KASHYAP, S., KIM, T., AND CHIDAMBARAM, V. Recipe: converting concurrent DRAM indexes to persistent-memory indexes. In *Proceedings of the 27th ACM Symposium on Operating Systems Principles, SOSP 2019, Huntsville, ON, Canada, October 27-30, 2019* (2019), T. Brecht and C. Williamson, Eds., ACM, pp. 462–477.
- [28] LEIS, V., KEMPER, A., AND NEUMANN, T. The adaptive radix tree: Artful indexing for main-memory databases. In *29th IEEE International Conference on Data Engineering, ICDE 2013, Brisbane, Australia, April 8-12, 2013* (2013), C. S. Jensen, C. M. Jermaine, and X. Zhou, Eds., IEEE Computer Society, pp. 38–49.
- [29] LEPERS, B., BALMAU, O., GUPTA, K., AND ZWAENPOEL, W. KVell: the design and implementation of a fast persistent key-value store. In *Proceedings of the 27th ACM Symposium on Operating Systems Principles, SOSP 2019, Huntsville, ON, Canada, October 27-30, 2019* (2019), T. Brecht and C. Williamson, Eds., ACM, pp. 447–461.
- [30] LIM, H., FAN, B., ANDERSEN, D. G., AND KAMINSKY, M. SILT: a memory-efficient, high-performance key-value store. In *Proceedings of the 23rd ACM Symposium on Operating Systems Principles 2011, SOSP 2011, Cascais, Portugal, October 23-26, 2011* (2011), T. Wobber and P. Druschel, Eds., ACM, pp. 1–13.
- [31] LINKEDIN, M. Project Voldemort - a distributed database. <https://www.project-voldemort.com/voldemort>. Accessed: 2020-12-10.
- [32] LIU, J., CHEN, S., AND WANG, L. LB+-trees: Optimizing persistent index performance on 3D XPoint memory. *PVLDB* 13, 7 (2020), 1078–1090.
- [33] LTD, O. OrientDB. <https://www.orientdb.org/>. Accessed: 2020-12-10.
- [34] MAO, Y., KOHLER, E., AND MORRIS, R. T. Cache craftiness for fast multicore key-value storage. In *European Conference on Computer Systems, Proceedings of the Seventh EuroSys Conference 2012, EuroSys ’12, Bern, Switzerland, April 10-13, 2012* (2012), P. Felber, F. Belloso, and H. Bos, Eds., ACM, pp. 183–196.
- [35] MÁRMOL, L., GUERRA, J., AND AGUILERA, M. K. Non-volatile memory through customized key-value stores. In *8th USENIX Workshop on Hot Topics in Storage and File Systems, HotStorage 2016, Denver, CO, USA, June 20-21, 2016* (2016), N. Agrawal and S. H. Noh, Eds., USENIX Association.
- [36] MERRITT, A., GAVRILOVSKA, A., CHEN, Y., AND MILOJICIC, D. S. Concurrent log-structured memory for many-core key-value stores. *PVLDB* 11, 4 (2017), 458–471.
- [37] MICROSOFT. FASTER - Key Features. <https://microsoft.github.io/FASTER/>. Accessed: 2021-04-25.
- [38] MICROSOFT. FasterKV basics - FASTER. <https://microsoft.github.io/FASTER/docs/fasterkv-basics/#checkpointing-and-recovery>. Accessed: 2020-12-07.
- [39] MOHAN, C., HADERLE, D., LINDSAY, B., PIRAHESH, H., AND SCHWARZ, P. Aries: A transaction recovery method supporting fine-granularity locking and partial rollbacks using write-ahead logging. *ACM Transactions on Database Systems* 17, 1 (Mar. 1992), 94–162.
- [40] MORRISON, D. R. PATRICIA - practical algorithm to retrieve information coded in alphanumeric. *J. ACM* 15, 4 (1968), 514–534.
- [41] NGUYEN, G., DLUGOLINSKY, S., BOBÁK, M., TRAN, V. D., GARCÍA, Á. L., HEREDIA, I., MALÍK, P., AND HLUCHÝ, L. Machine learning and deep learning frameworks and libraries for large-scale data mining: a survey. *Artif. Intell. Rev.* 52, 1 (2019), 77–124.
- [42] NIX-RUST PROJECT DEVELOPERS, T. nix — crates.io: Rust package registry. <https://crates.io/crates/nix>. Accessed: 2020-04-15.
- [43] PIRZADEH, P., TATEMURA, J., PO, O., AND HACIGÜMÜS, H. Performance evaluation of range queries in key value stores. *J. Grid Comput.* 10, 1 (2012), 109–132.
- [44] PROJECT, T. G. Asynchronous I/O (the GNU C library). https://www.gnu.org/software/libc/manual/html_node/Asynchronous-1_002fO.html. Accessed: 2020-04-15.
- [45] RAJU, P., KADEKODI, R., CHIDAMBARAM, V., AND ABRAHAM, I. PebblesDB: Building key-value stores using fragmented log-structured merge trees. In *Proceedings of the 26th Symposium on Operating Systems Principles, Shanghai, China, October 28-31, 2017* (2017), ACM, pp. 497–514.
- [46] RAJU, P., PONNAPALLI, S., KAMINSKY, E., OVED, G., KEENER, Z., CHIDAMBARAM, V., AND ABRAHAM, I. mLSM: Making authenticated storage faster in Ethereum. In *10th USENIX Workshop on Hot Topics in Storage and File Systems, HotStorage 2018, Boston, MA, USA, July 9-10, 2018* (2018), A. Goel and N. Talagala, Eds., USENIX Association.
- [47] SHEN, Z., CHEN, F., JIA, Y., AND SHAO, Z. Optimizing flash-based key-value cache systems. In *8th USENIX Workshop on Hot Topics in Storage and File Systems, HotStorage 2016, Denver, CO, USA, June 20-21, 2016* (2016), N. Agrawal and S. H. Noh, Eds., USENIX Association.
- [48] TEAM, T. R. Rust programming language. <https://www.rust-lang.org/>. Accessed: 2020-05-26.
- [49] WANG, S., DINH, T. T. A., LIN, Q., XIE, Z., ZHANG, M., CAI, Q., CHEN, G., OOI, B. C., AND RUAN, P. Forkbase: An efficient storage engine for blockchain and forkable applications. *PVLDB* 11, 10 (2018), 1137–1150.
- [50] WU, X., XU, Y., SHAO, Z., AND JIANG, S. LSM-trie: An LSM-tree-based ultra-large key-value store for small data items. In *2015 USENIX Annual Technical Conference, USENIX ATC ’15, July 8-10, Santa Clara, CA, USA* (2015), S. Lu and E. Riedel, Eds., USENIX Association, pp. 71–82.

- [51] ZHANG, H., LIM, H., LEIS, V., ANDERSEN, D. G., KAMINSKY, M., KEETON, K., AND PAVLO, A. Surf: Practical range query filtering with fast succinct tries. In *Proceedings of the 2018 International Conference on Management of Data, SIGMOD Conference 2018, Houston, TX, USA, June 10-15, 2018* (2018), G. Das, C. M. Jermaine, and P. A. Bernstein, Eds., ACM, pp. 323–336.
- [52] ZHANG, J., WU, S., TAN, Z., CHEN, G., CHENG, Z., CAO, W., GAO, Y., AND FENG, X. S3: A scalable in-memory skip-list index for key-value store. *PVLDB* 12, 12 (2019), 2183–2194.