

Influence functions for a hysteretic deformable mirror with a high density 2D array of actuators

A.E.M. SCHMERBAUCH^{1,*}, M.A. VASQUEZ-BELTRAN¹, A.I. VAKIS², R. HUISMAN³, AND B. JAYAWARDHANA¹

¹Engineering and Technology Institute Groningen - Discrete Technology & Production Automation, Faculty of Science and Engineering, University of Groningen, 9747AG Groningen, The Netherlands

²Engineering and Technology Institute Groningen - Computational Mechanical and Materials Engineering, Faculty of Science and Engineering, University of Groningen, 9747AG Groningen, The Netherlands

³Netherlands Institute for Space Research, Groningen, The Netherlands

*Corresponding author: a.e.m.schmerbauch@rug.nl

Appl. Opt. 59, 8077-8088 (2020)

We present modeling and analysis of a hysteretic deformable mirror where the facesheet interacts with a continuous layer of piezoelectric material that can be actuated distributively by a matrix of electrodes through multiplexing. Moreover, a method for calculating the actuator influence functions is described considering the particular arrangement of electrodes. The results are presented in a semi-analytical model to describe the facesheet's deformation caused by a high density array of actuators, and validated in a simulation. The proposed modeling of an interconnection layout of electrodes is used to determine the optimal pressures the actuators have to exert for achieving a desired surface deformation. © 2020 Optical Society of America

<https://doi.org/10.1364/AO.397472>

1. INTRODUCTION

Deformable mirrors (DMs) are instruments used for the correction of light wavefront aberrations in many imaging and non-imaging applications such as three-dimensional (3D) imaging to increase the realism of depth perception [1, 2], microscopes to correct static lenses [3], medical applications [4], or industrial applications like laser material processes [5]. In general, DMs are distinguished in segmented and continuous facesheet mirrors, and can be further classified by means of their actuator type that is mounted below the reflective top layer to deform the mirror surface. Depending on the application, various actuator technologies are used which include, for example, piezoelectric [6–8], electrostatic [9], thermal [10, 11], magneto-restrictive and shape memory alloy actuators [12] as well as voice coil/ reluctance actuators [13, 14]. Furthermore, DMs are applied in adaptive optical systems and key instruments for space telescopes. When a distorted incoming wavefront arrives at the telescope, a wavefront sensor is used to measure the wavefront distortion and subsequently used to adjust the shape of DM in order to correct the distorted wavefront. Future large space telescopes like LUVOIR [15] use coronagraphic instruments for high-contrast imaging of exoplanets. Although thousands of exoplanets have been identified, the current state of technology limits our capability in measuring and understanding these exoplanets beyond their mass, radius, orbital period and distance to the host star. To

overcome these challenges and provide the required capabilities for a direct exoplanet imaging space mission, DMs strive among others after high actuator density, meaning that the number of actuators must be increased to the maximum that can still guarantee practical operability for wire bonding, harness and electronics. DMs usually have a number of actuators ranging from 100 to 6000 but rarely higher [14, 16, 17]. One of the major limitations for employing the mirrors with a large number of actuators on a space mission is the reliability of the associated cable harness and electronics. If every actuator has to be driven continuously to hold a specific position, a dedicated channel consisting of a digital-to-analog converter and a high voltage amplifier is required per actuator, resulting in bulky electronics.

The recently presented concept of a high pixel number deformable mirror utilizing piezoelectric hysteresis for stable shape configurations [18], abbreviated hysteretic deformable mirror (HDM), demonstrates what we believe to the best of our knowledge is a new DM concept whose actuation mechanism consists of multilayered piezoelectric actuators with high hysteresis. Figure 1 shows a schematic illustration of the HDM. The high hysteresis of the newly developed piezoelectric material guarantees a remnant deformation of the mirror surface after the input has been removed. This property enables the combination of a simple electrode layout to define actuators at the intersections and use multiplexing to address those. The control of the remnant of a single actuator is presented in [19].

The HDM focuses on applications where typically slowly varying disturbances (> 1 Hz) must be corrected with extremely high accuracy ($< \text{nm}$) and spatial frequency content, as it is the case for LUVOIR. Due to the HDM's design and working principle it is possible to employ a large number of actuators (128×128) on an approximate surface area of 900 mm^2 and reach a high-resolution accuracy in correcting wavefront aberrations. In addition, it benefits from time-division multiplexing which reduces the number of wires needed to connect and address the actuators. Subsequently, the HDM provides a very simple electrode layout, as illustrated in Figure 2. The top and bottom electrodes are rotated by 90° to form intersecting areas of the electrodes presenting the actuators. The actuation is bundled by sharing the same electrodes for actuators along a line. The voltage is transmitted over a shared top electrode while the corresponding bottom electrode for the desired actuator is grounded.

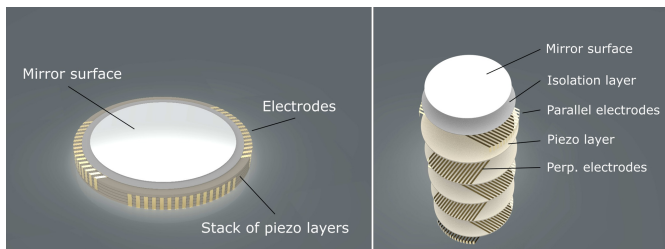

Fig. 1. 3D visualization of the mirror concept. The HDM consists of multilayered piezoelectric actuators which can deform the mirror surface by application of an electrical potential to the electrodes. Exploded view of the HDM with respective description of the individual components: mirror surface, isolation layer, parallel electrodes, piezo layers and perpendicular electrodes.

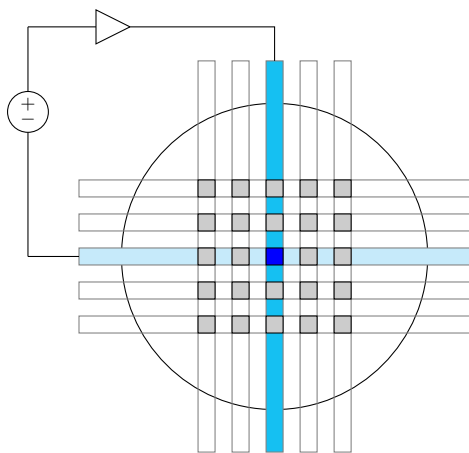

Fig. 2. Conceptual electrode layout of the hysteretic deformable mirror from the top view. As an example in the illustration, the central actuator is actuated by application of an electrical potential to center top and bottom electrode which are visualized in blue while the other (not activated) actuators are represented in gray.

Motivated by this novel concept, we present the modeling and analysis of a mirror's facesheet that is subjected to the key characteristics of the HDM including a high actuator density

and an interconnection layout. The mirror is described with a mechanical model to show the relation between the facesheet deflection and the pressures applied by the actuators. We follow the approach presented by Claflin and Bareket [20] in assuming that the deflection is governed by Poisson's equation. To guarantee a high accuracy in modeling, we incorporate the particular arrangement of the electrodes in the HDM into the solution to Poisson's equation and present the analytical solutions for the parametrization of squared electrodes as one of our contributions. In addition, an actuator model is introduced incorporating that the actuator's pressure is a function of hysteresis modeled by the Preisach operator. Based on this, we can compute the required pressures to fit several Zernike polynomials [21], which are the preferred representation for light wavefront aberrations in adaptive optical systems. The simulation is performed for low actuator numbers to demonstrate the calculation method with the given conditions, and high actuator numbers which will allow a high spatial frequency wavefront correction. The results including the method's accuracy and limits of applicability are discussed.

The paper has four sections. Section 2 presents the semi-analytical plate model to calculate the facesheet deflection caused by a high density array with square pressure planes of the actuators interacting with the facesheet. Section 3 describes the least-square fitting to determine optimal actuator pressures for representing wavefront aberrations and presents simulation results for a 5×5 as well as a 129×129 actuator array. Finally, results are discussed and the conclusions are given in Section 4.

2. SEMI-ANALYTICAL PLATE MODEL

An influence function defines the characteristic shape of the mirror surface corresponding to the deformation caused by one actuator. Several methods currently exist for modeling these influence functions of continuous facesheet mirrors. Besides the usage of Gauss functions and splines [22–24], or biharmonic plate equation [25], influence functions can be modeled by application of Kirchhoff or van Kármán theory [26–28] for plate deformations smaller than the plate thickness. Methods using the thin plate theory to calculate influence functions for real time computation for specific mirror geometries are given in [29, 30]. Furthermore, models based on the Kirchhoff plate model, for example, include assumptions for actuator forces that either presuppose the exerted force as point load or approximated electrode areas with constantly distributed loads as well as boundary conditions presenting circularly clamped DMs [20, 31] or a free outer edge [32]. Next to these modeling approaches which mainly consider the static characteristics, detailed review and analysis of DM's dynamic properties for control purposes can be found in [33].

To determine the influence functions as precisely as possible with static characteristics, it is necessary to define the interaction areas according to their actual shapes. Given the concept of the HDM, the electrodes have an interconnection layout creating pressure planes lying under a thin circular facesheet. Since the upper electrodes are the closest layer to the facesheet besides the comparable thin isolation layer, which is neglected for simplicity of our modeling, we idealized these pressure planes as squares. The actuators are separated by a specified distance. To describe the surface displacement, it is necessary to integrate over the area of each pressure plane. Therefore, each plane is separated into several areas which can be described by a coordinate transformation using Cartesian coordinates as well as the radial and

angular limits. It is assumed that the thickness of electrodes can be neglected and the piezoelectric actuators modeled as springs in parallel to a force source over an area which creates pressure on the facesheet.

A. Determination of influence matrix

We consider the Poisson equation [34]

$$\nabla^2 z = -\frac{q}{T} \quad (1)$$

which governs the relation between small surface displacements z of a thin facesheet with surface tension T generated by an exerted pressure q . The solution to Poisson's equation in polar coordinates (r, ϕ) can be given by

$$z(r, \phi, \bar{r}, \bar{\phi}) = C \iint_A \mathcal{F}(r, \phi, \bar{r}, \bar{\phi}(\bar{r})) q(\bar{r}, \bar{\phi}) d\bar{\phi} d\bar{r} \quad (2)$$

with

$$A = \{(\bar{r}, \bar{\phi}) | \phi_1(\bar{r}) \leq \bar{\phi} \leq \phi_2(\bar{r}), 0 \leq \bar{r} \leq 1\} \quad (3)$$

where $z(r, \phi)$ is the out-of-plane displacement of the thin facesheet, $(\bar{r}, \bar{\phi})$ are the integration variables, $q(\bar{r}, \bar{\phi})$ are the distributed forces over the particular electrode area, and constant $C = a^2/T$ contains the relation between the facesheet radius a and the surface tension for normalization of the function \mathcal{F} to unity. Edge deflection and slopes are both equal to zero. Furthermore, \mathcal{F} is defined as

$$\mathcal{F}(r, \phi, \bar{r}, \bar{\phi}(\bar{r})) = \begin{cases} f_1(r, \phi, \bar{r}, \bar{\phi}(\bar{r})) & \text{if } 0 < \bar{r} < r \\ f_2(r, \phi, \bar{r}, \bar{\phi}(\bar{r})) & \text{if } r < \bar{r} < 1. \end{cases} \quad (4)$$

The resulting deflection will be the integral of $z(r, \phi, \bar{r}, \bar{\phi})$ over the area A of the facesheet

$$z(r, \phi) = \frac{q(r, \phi)a^2}{2\pi T} \int_0^1 \int_0^{2\pi} \mathcal{F}(r, \phi, \bar{r}, \bar{\phi}(\bar{r})) d\bar{\phi} d\bar{r} \quad (5)$$

assuming that $q(\bar{r}, \bar{\phi})$ is a piecewise constant function on $R_1 < r < R_2$ which gives $q(r, \phi)$. Note that R_1 and R_2 designate the smallest and greatest radius for describing the electrodes, respectively.

Following the approach of Clafin and Bareket [20], the equation for calculation of the surface deflection on a specific point on the clamped facesheet can be formulated as

$$z(r, \phi) = \sum_{j=1}^{N_e} \mathcal{M}_{(r, \phi)j} q_{(r, \phi)j} \quad (6)$$

where \mathcal{M} represents the coefficients derived from the solutions of the Poisson equation, $q_{(r, \phi)j}$ are piecewise constant pressures exerted on the respective j -th electrode, and N_e is the total number of electrodes.

The exact shape of an electrode is defined via a coordinate transformation. This allows us to implement the information later to the Poisson's equation (Eq. 2) and find a solution. The electrode is split into parts based on areas of radial limits. These radial limits are used to implement the transformation from Cartesian to polar coordinates. Thus, ϕ depends on r . For convenience, the integration with respect to ϕ is performed first, and results in

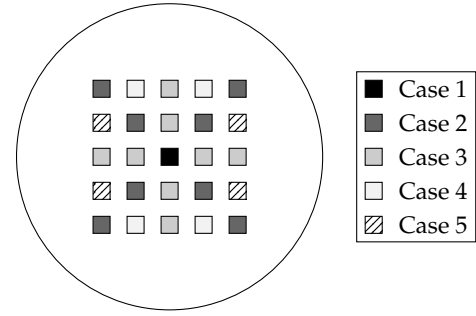

Fig. 3. Conceptual top view of a 5×5 actuator array to illustrate the classification of cases which arises from the geometric description and modeling method.

$$z(r, \phi) = \frac{q(r, \phi)}{2\pi} C \left\{ -\ln(r) \int_0^r \bar{r} (\phi_2(\bar{r}) - \phi_1(\bar{r})) \right. \\ \left. - \bar{r} \sum_{n=1}^{\infty} \frac{1}{n^2} \left((\bar{r}r)^n - \left(\frac{\bar{r}}{r}\right)^n \right) \right. \\ \left. \times [\sin(n(\phi_2(\bar{r}) - \phi)) - \sin(n(\phi_1(\bar{r}) - \phi))] d\bar{r} \right. \\ \left. + \int_r^1 \bar{r} \ln\left(\frac{1}{\bar{r}}\right) (\phi_2(\bar{r}) - \phi_1(\bar{r})) \right. \\ \left. - \bar{r} \sum_{n=1}^{\infty} \frac{1}{n^2} \left((\bar{r}r)^n - \left(\frac{r}{\bar{r}}\right)^n \right) \right. \\ \left. \times [\sin(n(\phi_2(\bar{r}) - \phi)) - \sin(n(\phi_1(\bar{r}) - \phi))] d\bar{r} \right\}. \quad (7)$$

The introduced coordinate transformation is inserted and the integration with respect to r is solved as a function of the position of the electrodes. We define five cases according to the actuator position (Figure 3), as follows: *Case 1*, central actuator; *Case 2*, diagonal actuators; *Case 3*, midline actuators; *Case 4*, actuators above the diagonals; and *Case 5*, actuators below the diagonal. The definition of each radial limit can be found in Table 1, and is visualized in Figure 4-8 together with a respective pressure plane.

The detailed summary of the calculation of the coefficients resulting from the solution to Poisson's equation can be found in Appendices A to G.

A.1. Case 1 - central actuator

The central actuator (visualized in Figure 4) was described by use of two radial limits, r_1 and r_{1e} , where r_1 denotes the radius measured from the center to the corner points and r_{1e} denotes an extra radius measured from the center to the inner side length. The calculation of coefficients for this case can be found in Appendix C.

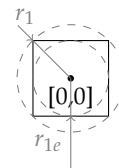

Fig. 4. Definitions of the radial limits to describe *Case 1*, central actuator.

A.2. Case 2 - diagonal actuators

The actuators that lie on the diagonals (visualized in Figure 5) were described by use of three radial limits: $r_1, r_2 = r_3$ and r_4 . The numbering of the radii is systematically distributed according to the corner position. The calculation of coefficients for this case can be found in Appendix D.

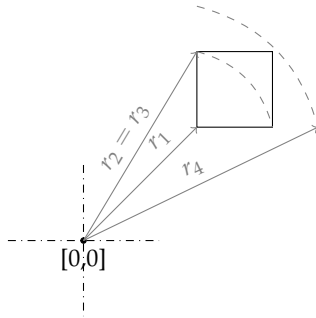

Fig. 5. Definitions of the radial limits to describe Case 2, diagonal actuator.

A.3. Case 3 - midline actuators

The actuators that lie on the midlines (visualized in Figure 6) were described by use of four radial limits: r_{1e}, r_1, r_4 and r_{4e} . r_1 and r_4 denote radii measured from the center to certain corner points and r_{1e} and r_{4e} denote extra radii indicating inner side lengths. The calculation of coefficients for this case can be found in Appendix E.

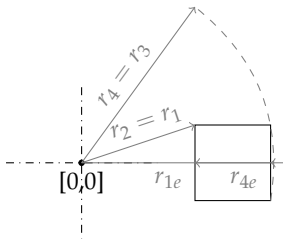

Fig. 6. Definitions of the radial limits to describe Case 3, mid-line actuator.

A.4. Case 4 - actuators above the diagonal

The actuators that lie above the diagonals (visualized in Figure 7) were described by use of four radial limits: r_1, r_3, r_2 and r_4 . The numbering of the radii is systematically distributed according to the corner position. The calculation of coefficients for this case can be found in Appendix F.

A.5. Case 5 - actuators below the diagonal

The actuators that lie below the diagonals (visualized in Figure 8) were described by use of four radial limits: r_1, r_3, r_3 and r_4 . The numbering of the radii is systematically distributed according to the corner position. The calculation of coefficients for this case can be found in Appendix G.

B. Actuator model

The actuators become coupled through the stiffness of the facesheet. Usually, DMs profit by low inter-actuator coupling, denoting the mechanical coupling between neighboring actuators, which improves the surface accuracy. If significant inter-actuator coupling is present, this needs to be considered in the

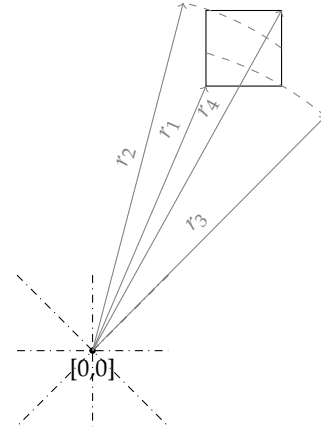

Fig. 7. Definitions of the radial limits to describe Case 4, actuators above the diagonal.

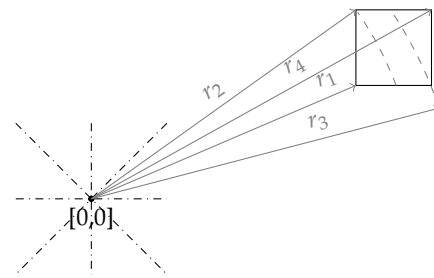

Fig. 8. Definitions of the radial limits to describe Case 5, actuators below the diagonal.

Table 1. Definition of radial limits for splitting the electrode areas.

Case 1	Case 2	Case 3	Case 4	Case 5
$\bar{r} = 0$	$\bar{r} \leq r_1$	$\bar{r} \leq r_{1e}$	$\bar{r} \leq r_1$	$\bar{r} \leq r_1$
$\bar{r} \geq r_1$	$\bar{r} \geq r_4$	$\bar{r} \geq r_4$	$\bar{r} \geq r_4$	$\bar{r} \geq r_4$
$0 < \bar{r} \leq r_{1e}$	$r_1 < \bar{r} \leq r_2$	$r_{1e} < \bar{r} \leq r_1$	$r_1 < \bar{r} \leq r_3$	$r_1 < \bar{r} \leq r_2$
$r_{1e} < \bar{r} < r_1$	$r_2 < \bar{r} < r_4$	$r_1 < \bar{r} \leq r_{4e}$	$r_3 < \bar{r} \leq r_2$	$r_2 < \bar{r} \leq r_3$
		$r_{4e} < \bar{r} < r_4$	$r_2 < \bar{r} < r_4$	$r_3 < \bar{r} < r_4$

modeling and control processes [6]. Here, we introduce the model of actuators based on two components, which correspond to a spring in parallel with a force source (Figure 9).

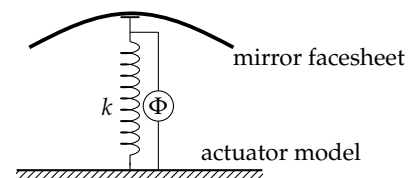

Fig. 9. Simplified actuator model, modeled by a stiffness k in parallel to a force source over an area Φ acting on the mirror facesheet.

The pressure term $q(r, \phi)$ can be split so that it captures both components in terms of stiffness and force source over an area.

Consequently, the relation from Equation Eq. (6) may be described by

$$z(r, \phi) = \sum_{j=1}^{N_e} \mathcal{M}_{(r, \phi)j} \left(\Phi_{Pj}(V) - k_j \tilde{z}_j \right) \quad (8)$$

with

$$\Phi_{Pj}(V) = Y_j \Phi_{Tj}(V) \quad (9)$$

and

$$\tilde{z}_j := \frac{\sum_{i \in E_j} z_i / n_e}{A_e} \quad (10)$$

where $\Phi_{Pj}(V)$ denotes the Preisach operator capturing the highly nonlinear hysteresis of the actuators in regard to the total deformation in relation of the initial thickness dimension, the diagonal matrix containing the Young's modulus Y_j , the longitudinal elongations of the actuators $\Phi_{Tj}(V)$, the diagonal stiffness matrix containing the actuators' stiffness k_j , and the mean surface deflection above the respective electrode with area A_e \tilde{z}_j calculated by means of n_e surface displacement points z_i on a specific position within the electrode area. It is assumed that all the actuators are identical and can exert an asymmetric butterfly loop as exemplary presented in Figure 10. A framework to model the electric-field dependence on the strain in piezoelectric materials purposely designed to exhibit loops with remnant deformation was presented by Jayawardhana et al. [35] based on the use of the Preisach operator. The complete formal definition of the Preisach operator is given in [36].

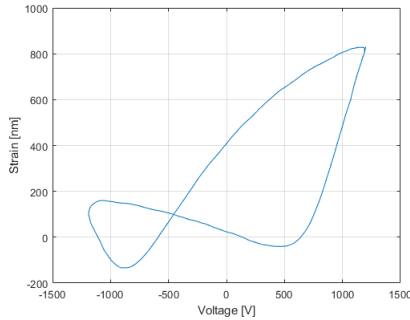

Fig. 10. Asymmetric butterfly hysteresis loop with remnant deformation, the measured data of which was collected from previous material tests. The axial displacement was measured while a certain voltage was applied.

3. RESULTS AND DISCUSSION

A. 2D pattern for Influence Functions of Case 1 - 5

The influence function of every case can be seen in Figure 11. The actuators were individually addressed, and their arrangement corresponds to the 5×5 actuator array that is exemplarily visualized in Figure 3.

B. Least-square fitting

The preferred representation for light wavefront aberrations in adaptive optical systems is via Zernike polynomials. They are defined on a unit circle using polar coordinates (r, θ) as functions of azimuthal frequency m and radial degrees n , where $m \leq n$. The set of polynomials [21] can be given by

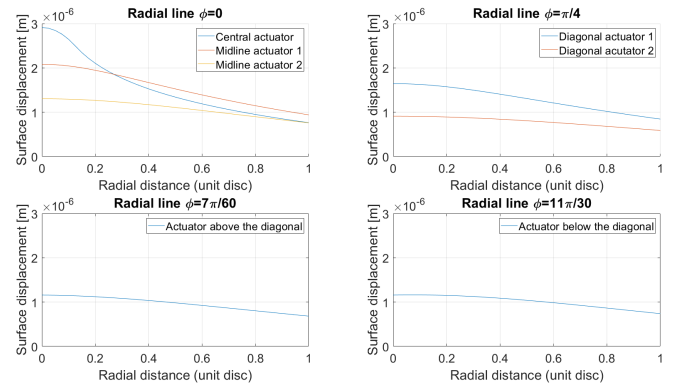

Fig. 11. Influence functions in the optically active area for Case 1 and Case 3 (top, left), Case 2 (top, right), Case 4 (bottom, left) and Case 5 (bottom, right) plotted along the radial line ϕ . Each actuator was addressed individually with a pressure of 0.01 Nm^{-2} .

$$\begin{aligned} Z_n^m(r, \theta) &= R_n^m(r) \cos(m\theta) \quad \text{for } m \geq 0 \\ Z_n^{-m}(r, \theta) &= R_n^m(r) \sin(m\theta) \quad \text{for } m < 0 \end{aligned} \quad (11)$$

where

$$R_n^m(r) = \sum_{S=0}^{(n-m)/2} \frac{(-1)^S (n-S)! r^{n-2S}}{S! [(n+m)/2 - S]! [(n-m)/2 - S]!}. \quad (12)$$

To calculate the required pressure terms to fit several Zernike polynomials, each displacement of a respective point on the facesheet which is defined by (r, ϕ) is fit to the corresponding point on Zernike polynomials. An over-determined set of equations is solved in the least-square sense resulting in

$$\Phi = (\mathcal{M}^T \mathcal{M})^{-1} \mathcal{M}(z_d + \mathcal{M}k\tilde{z}_d). \quad (13)$$

which aims at minimizing the root-mean-square deviation (RMSD) between the two quantities.

C. Simulation results

Using MATLAB R2019a, a low density array with 5×5 actuators and a high density array with 129×129 actuators were generated. To decrease the computational effort in the latter case, the coefficient calculations were executed in parallel per 5 actuators and run in a compute cluster (Peregrine HPC cluster). For all experiments, we used a partition of two Intel Xeon E5 2680 v3 or v4 (2.50GHz or 2.40GHz respectively) CPUs with 5GB of memory. Thereby, the computational time was decreased to about 2h when all jobs ran in parallel.

To assess the mechanical model, a second simulation in Matlab was generated fitting the mirror surface to selected Zernike polynomials. The procedure of this approach included three steps. The first step consisted of reducing the mirror surface to an optically active area due to the boundary conditions to circumvent an increasing fitting error caused by zero deflection at the clamped edge. Secondly, a mask was generated to match selected points of the Zernike polynomial disc plot to the surface points of the mirror. This mask was created with a partition in radial and angular coordinates according to $r_0 < r_1 < \dots < r_{(n-1)} < r_n$ with $r_0 = 0$ and $r_n = 1$, and

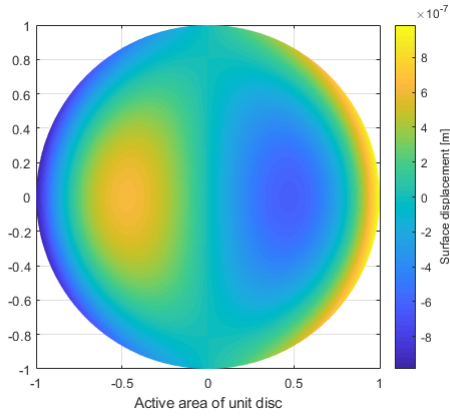

Fig. 12. 129×129 actuator array fitted to Zernike polynomial Z_3^1 with a peak-to-valley amplitude of $1.972\mu\text{m}$ in a graphic representation showing the active area of the mirror as unit disc with vertical colorbar giving the surface displacement.

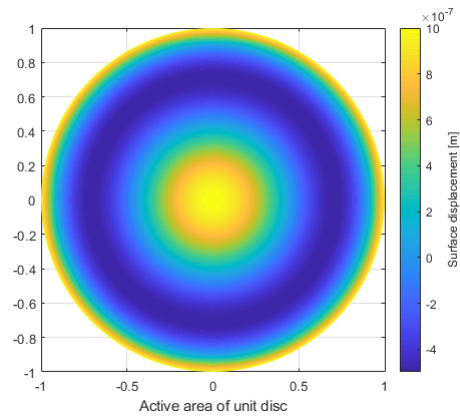

Fig. 14. 129×129 actuator array fitted to Zernike polynomial Z_4^0 with a peak-to-valley amplitude of $1.199\mu\text{m}$ in a graphic representation showing the active area of the mirror as unit disc with vertical colorbar giving the surface displacement.

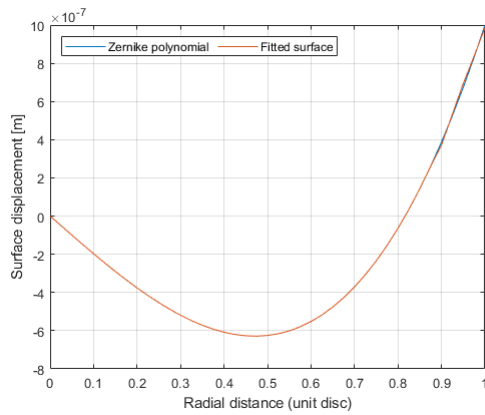

Fig. 13. Surface displacement along the radial line $\phi = 0$ for a 129×129 actuator array fitted to Zernike polynomial Z_3^1 with a peak-to-valley amplitude of $1.972\mu\text{m}$

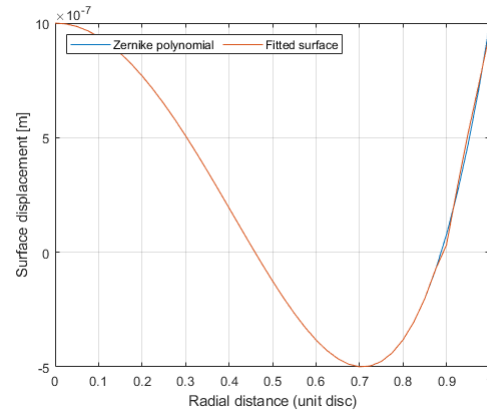

Fig. 15. Surface displacement along the radial line $\phi = 0$ for a 129×129 actuator array fitted to Zernike polynomial Z_4^0 with a peak-to-valley amplitude of $1.199\mu\text{m}$

$\phi_0 < \phi_1 < \dots < \phi_{(n-1)} < \phi_n$ with $\phi_0 = 0$ and $\phi_n = 2\pi$ respectively. In the third step, the RMSD of the estimator z_d with respect to the actual surface deflection z was calculated (Eq. (14)) to evaluate the mirror accuracy by

$$RMSD(z) = \sqrt{\frac{\sum_{x=1}^X (z_x - z_{d_x})^2}{x}}. \quad (14)$$

There were 4961 surface points selected based on the described partition over a diameter of 0.8 which corresponds to the active area. The facesheet surface tension amounted to 15 N m^{-1} and total mirror radius normalized to 1. Figures 12-15 show the results for a 129×129 actuator array of fitting the mirror surface to lower order Zernike polynomials while Figure 16 and 17 show the result for a selected higher order polynomial. Table 2 summarizes the RMSDs for the first 28 Zernike polynomials and selected higher order ones fitted with a peak-to-valley amplitude in the region of approximately 1.5 to $2\mu\text{m}$ with a low and high density array.

Considering the fitting results for a low density array with 5×5 actuators (25 actuators in the active area), the intersection

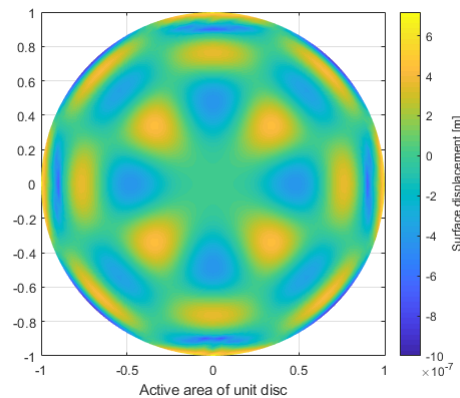

Fig. 16. 129×129 actuator array fitted to Zernike polynomial Z_{10}^4 with a peak-to-valley amplitude of $1.718\mu\text{m}$ in a graphic representation showing the active area of the mirror as unit disc with vertical colorbar giving the surface displacement.

Table 2. Summary of Root-Mean-Square Deviations (RMSDs) for selected Zernike polynomials (ZPs) with a 5×5 (Low Density (LD)) and 129×129 actuator array (High Density (HD)).

ZPs	LD: RMSDs in [%]	HD: RMSDs in [%]
Z_1^{-1}	4.426	0.001433
Z_1^1	4.352	0.001373
Z_2^{-2}	3.806	0.000298
Z_2^0	12.840	0.065971
Z_2^2	9.498	0.004775
Z_3^{-3}	10.138	0.007609
Z_3^{-1}	13.937	0.131942
Z_3^1	13.756	0.134622
Z_3^3	9.974	0.007343
Z_4^{-4}	11.376	0.005252
Z_4^{-2}	12.662	0.082268
Z_4^0	25.917	0.524411
Z_4^2	20.755	0.409452
Z_4^4	13.069	0.011954
Z_5^{-5}	13.847	0.017128
Z_5^{-3}	18.909	0.406282
Z_5^{-1}	18.838	0.675500
Z_5^1	18.674	0.692096
Z_5^3	18.717	0.400501
Z_5^5	13.649	0.016273
Z_6^{-6}	14.903	0.009467
Z_6^{-4}	20.851	0.364835
Z_6^{-2}	18.077	0.346565
Z_6^0	25.742	1.735849
Z_6^2	17.145	1.670824
Z_6^4	16.980	0.729995
Z_6^6	14.790	0.049802
Z_{10}^{-10}	16.216	0.087481
Z_{10}^{-8}	18.114	1.420633
Z_{10}^{-6}	18.901	2.341578
Z_{10}^{-4}	20.592	2.417903
Z_{10}^{-2}	22.680	1.451910
Z_{10}^0	27.243	6.092243
Z_{10}^2	21.649	6.225307
Z_{10}^4	18.076	4.505920
Z_{10}^6	18.868	3.345968
Z_{10}^8	17.221	1.468534
Z_{10}^{10}	17.303	0.271556

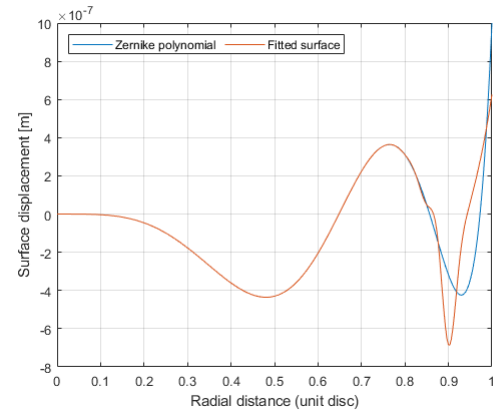

Fig. 17. Surface displacement along the radial line $\phi = 0$ for a 129×129 actuator array fitted to Zernike polynomial Z_{10}^4 with a peak-to-valley amplitude of $1.718 \mu m$.

layout became clear and the positions of the few actuators play a major role for the final results. The fitting errors are between 3.8% and 27.2%. Comparing these results to a high density array with 129×129 actuators (16073 actuators in the active area, 568 actuators outside), we observe that the RMSDs decrease drastically. With 129×129 actuators, we have deviations between 0.000298% and 6.23% for the selected polynomials. For higher order polynomials corner effects are visible. Although the fitting errors for low and high density arrays behave in a similar manner with increasing degree of the polynomial, it is noticeable that with Zernike polynomials in the cosine phase the RMSD is slightly higher due to the square grid the HDM is characterized with. For further fitting improvement, the position of the square region, in which the actuators are created due to the interconnection of electrodes, might be adjusted with the active area to cover completely upper, lower, left and right corner of the unit disc.

4. CONCLUSIONS

This study investigated the fundamental characteristics of actuator positions of high density arrays and presented a generalization of cases to calculate every actuator position of deformable mirrors for application in what we believe to be the best of our knowledge is a novel hysteretic deformable mirror. Based on the introduced coordinate transformation while solving the Poisson equation, it was possible to model exactly the shape of the pressure planes and guarantee a more realistic description of the actuator influence functions. By calculating the coefficient matrix in a cluster, the computational time was decreased which presents a usable method for computations on deformable mirrors with high actuator densities. Furthermore, the mirror model includes the mechanical coupling between the actuators and the facesheet. The presented results contribute to achieve a higher accuracy in modeling the actuator influence functions according to the actual properties of the DM, and therefore decrease fitting errors. It provides a framework on how to consider high actuator densities and calculate them in a reasonable way regarding actuator position case classification and computation time.

A. RESPECTIVE FORMULAS

For actuators of the right side of the plate, the left corner of a pressure plane is denoted with x_1 , the right corner with x_2 ,

the lower corner with y_1 and the upper corner with y_2 . The designation is mirrored with actuators on the left side of the plate. In general, it can be said that $|x_1| \leq |x_2|$ and $|y_1| \leq |y_2|$.

Table 3 summarizes the definition of all radial limits with coordinate transformations for splitting the electrode areas. Symbols which are assigned to reoccurring formulas are listed in Table 4.

Table 3. Definition of Radial Limits in Interval I with Coordinate Transformation for Splitting the Electrode Areas.

Case 1	Boundaries	Coordinate transformation
I_1	$0 \leq \bar{r} \leq r_{1e}$	$0 < \bar{\phi} < 2\pi$
I_{21}	$r_{1e} < \bar{r} < r_1$	$\arccos(x_2/\bar{r}) < \bar{\phi} < \arcsin(y_2/\bar{r})$
I_{22}		$\arcsin(y_2/\bar{r}) < \bar{\phi} < \arccos(x_1/\bar{r})$
I_{23}		$\arccos(x_1/\bar{r}) < \bar{\phi} < \arcsin(y_1/\bar{r})$
I_{24}		$\arcsin(y_1/\bar{r}) < \bar{\phi} < \arccos(x_2/\bar{r})$
Case 2	Boundaries	Coordinate transformation
I_1	$r_1 < \bar{r} \leq r_2$	$\arcsin(y_1/\bar{r}) < \bar{\phi} \leq \arccos(x_1/\bar{r})$
I_2	$r_2 < \bar{r} < r_4$	$\arccos(x_2/\bar{r}) < \bar{\phi} < \arcsin(y_2/\bar{r})$
Case 3	Boundaries	Coordinate transformation
I_{11}	$r_{1e} < \bar{r} \leq r_1$	$0 < \bar{\phi} \leq \arccos(x_1/\bar{r})$
I_{12}		$2\pi - \arccos(x_1/\bar{r}) < \bar{\phi} < 2\pi$
I_2	$r_1 < \bar{r} \leq r_{4e}$	$\arcsin(y_1/\bar{r}) < \bar{\phi} \leq \arcsin(y_2/\bar{r})$
I_{31}	$r_{4e} < \bar{r} < r_4$	$\arccos(x_2/\bar{r}) < \bar{\phi} < \arcsin(y_2/\bar{r})$
I_{32}		$\arcsin(y_1/\bar{r}) < \bar{\phi} < \arccos(x_2/\bar{r})$
Case 4	Boundaries	Coordinate transformation
I_1	$r_1 < \bar{r} \leq r_3$	$\arcsin(y_1/\bar{r}) < \bar{\phi} \leq \arccos(x_1/\bar{r})$
I_2	$r_3 < \bar{r} \leq r_2$	$\arccos(x_2/\bar{r}) < \bar{\phi} \leq \arccos(x_1/\bar{r})$
I_3	$r_2 < \bar{r} < r_4$	$\arccos(x_2/\bar{r}) < \bar{\phi} < \arcsin(y_2/\bar{r})$
Case 5	Boundaries	Coordinate transformation
I_1	$r_1 < \bar{r} \leq r_2$	$\arcsin(y_1/\bar{r}) < \bar{\phi} \leq \arccos(x_1/\bar{r})$
I_2	$r_2 < \bar{r} \leq r_3$	$\arcsin(y_1/\bar{r}) < \bar{\phi} \leq \arcsin(y_2/\bar{r})$
I_3	$r_3 < \bar{r} < r_4$	$\arccos(x_2/\bar{r}) < \bar{\phi} < \arcsin(y_2/\bar{r})$

B. NUMERICAL INTEGRATION

Here are the two sub-integrals that are solved numerically. 174 is the maximum number of n terms required for convergence [20], so

$$f_{1n} := \sum_{n=1}^{\infty} \int_{R_1}^{R_2} \frac{\bar{r}}{n^2} \left((\bar{r}r)^n - \left(\frac{\bar{r}}{r}\right)^n \right) \times [\sin(n(\phi_2(\bar{r}) - \phi)) - \sin(n(\phi_1(\bar{r}) - \phi))] d\bar{r}$$

Table 4. Assignment of Symbols to Reoccurring Formulas.

Symbol	Formula	Symbol	Formula
κ_{x_1}	$x_1 \sqrt{1 - x_1^2/r^2}$	κ_{y_1}	$y_1 \sqrt{1 - y_1^2/r^2}$
κ_{x_2}	$x_2 \sqrt{1 - x_2^2/r^2}$	κ_{y_2}	$y_2 \sqrt{1 - y_2^2/r^2}$
ϵ_{x_1}	$x_1 \sqrt{(r^2 - x_1^2)/r^2}$	ϵ_{y_1}	$y_1 \sqrt{(r^2 - y_1^2)/r^2}$
ϵ_{x_2}	$x_2 \sqrt{(r^2 - x_2^2)/r^2}$	ϵ_{y_2}	$y_2 \sqrt{(r^2 - y_2^2)/r^2}$
α_1	$\arccos(x_1/r)$	α_2	$\arccos(x_2/r)$
β_1	$\arcsin(y_1/r)$	β_2	$\arcsin(y_2/r)$
γ_1	$\arcsin(x_1/r)$	γ_2	$\arcsin(x_2/r)$

$$f_{2n} := \sum_{n=1}^{\infty} \int_{R_1}^{R_2} \frac{\bar{r}}{n^2} \left((\bar{r}r)^n - \left(\frac{r}{\bar{r}}\right)^n \right) \times [\sin(n(\phi_2(\bar{r}) - \phi)) - \sin(n(\phi_1(\bar{r}) - \phi))] d\bar{r}.$$

C. COEFFICIENT CALCULATION IN CASE 1

Here are the formulas for calculating the coefficients \mathcal{M} for actuators that can be categorized in Case 1:

1. $r_i = 0$

$$\mathcal{M} = (1/(2\pi)) \times ((f_{2(I_1)}(r_{1e})) + (f_{2(I_{21})}(r_1) - f_{2(I_{21})}(r_{1e})) + (f_{2(I_{22})}(r_1) - f_{2(I_{22})}(r_{1e})) + (f_{2(I_{23})}(r_1) - f_{2(I_{23})}(r_{1e})) + (f_{2(I_{24})}(r_1) - f_{2(I_{24})}(r_{1e})))$$

2. $0 < r_i \leq r_{1e}$

$$\mathcal{M} = (1/(2\pi)) \times ((f_{1(I_1)}(r_i) - f_{1(I_1)}(0)) - f_{1n(I_1)} + (f_{2(I_1)}(r_{1e}) - f_{2(I_1)}(r_i)) - f_{2n(I_1)} + (f_{2(I_{21})}(r_1) - f_{2(I_{21})}(r_{1e})) - f_{2n(I_{21})} + (f_{2(I_{22})}(r_1) - f_{2(I_{22})}(r_{1e})) - f_{2n(I_{22})} + (f_{2(I_{23})}(r_1) - f_{2(I_{23})}(r_{1e})) - f_{2n(I_{23})} + (f_{2(I_{24})}(r_1) - f_{2(I_{24})}(r_{1e})) - f_{2n(I_{24})})$$

3. $r_{1e} < r_i < r_1$

$$\mathcal{M} = (1/(2\pi)) \times ((f_{1(I_{21})}(r_i) - f_{1(I_{21})}(r_{1e})) - f_{1n(I_{21})} + (f_{1(I_{22})}(r_i) - f_{1(I_{22})}(r_{1e})) - f_{1n(I_{22})} + (f_{1(I_{23})}(r_i) - f_{1(I_{23})}(r_{1e})) - f_{1n(I_{23})} + (f_{1(I_{24})}(r_i) - f_{1(I_{24})}(r_{1e})) - f_{1n(I_{24})} + (f_{2(I_{21})}(r_1) - f_{2(I_{21})}(r_i)) - f_{2n(I_{21})} + (f_{2(I_{22})}(r_1) - f_{2(I_{22})}(r_i)) - f_{2n(I_{22})} + (f_{2(I_{23})}(r_1) - f_{2(I_{23})}(r_i)) - f_{2n(I_{23})} + (f_{2(I_{24})}(r_1) - f_{2(I_{24})}(r_i)) - f_{2n(I_{24})} + (f_{1(I_1)}(r_{1e}) - f_{1(I_1)}(0)) - f_{1n(I_1)})$$

4. $r_i \geq r_1$

$$\mathcal{M} = (1/(2\pi)) \times ((f_{1(I_1)}(r_{1e}) - f_{1(I_1)}(0)) - f_{1n(I_1)} + (f_{1(I_{21})}(r_1) - f_{1(I_{21})}(r_{1e})) - f_{1n(I_{21})} + (f_{1(I_{22})}(r_1) - f_{1(I_{22})}(r_{1e})) - f_{1n(I_{22})} + (f_{1(I_{23})}(r_1) - f_{1(I_{23})}(r_{1e})) - f_{1n(I_{23})} + (f_{1(I_{24})}(r_1) - f_{1(I_{24})}(r_{1e})) - f_{1n(I_{24})})$$

A. Sub-functions of f_1

$$\begin{aligned} f_{1(I_1)} &= -(\pi r^2 \log(r_i)) \\ f_{1(I_{21})} &= (r(-(\kappa_{x_2}) - \kappa_{y_2} + r\alpha_2 - r\beta_2) \log(r_i))/2 \\ f_{1(I_{22})} &= (r(\kappa_{x_1} + \kappa_{y_2} - r\alpha_1 + r\beta_2) \log(r_i))/2 \\ f_{1(I_{23})} &= (r(-(\kappa_{x_1}) - \kappa_{y_1} + r\alpha_1 - r\beta_1) \log(r_i))/2 \\ f_{1(I_{24})} &= (r(\kappa_{x_2} + \kappa_{y_1} - r\alpha_2 + r\beta_1) \log(r_i))/2 \end{aligned}$$

B. Sub-functions of f_2

$$\begin{aligned} f_{2(I_1)} &= 2\pi(r^2/4 + (r^2 \log(r^{-1}))/2) \\ f_{2(I_{21})} &= (3r\epsilon_{x_2})/4 + (3r\epsilon_{y_2})/4 - (r^2\alpha_2)/4 + (x_2^2\gamma_2)/2 \\ &\quad + (r^2\beta_2)/4 + (y_2^2\beta_2)/2 + (r(\epsilon_{x_2} - r\alpha_2) \log(r^{-1}))/2 \\ &\quad + (r(\epsilon_{y_2} + r\beta_2) \log(r^{-1}))/2 \\ f_{2(I_{22})} &= (-3r\epsilon_{x_1})/4 - (3r\epsilon_{y_2})/4 + (r^2\alpha_1)/4 - (x_1^2\gamma_1)/2 \\ &\quad - (r^2\beta_2)/4 - (y_2^2\beta_2)/2 - (r(\epsilon_{x_1} - r\alpha_1) \log(r^{-1}))/2 \\ &\quad - (r(\epsilon_{y_2} + r\beta_2) \log(r^{-1}))/2 \\ f_{2(I_{23})} &= (3r\epsilon_{x_1})/4 + (3r\epsilon_{y_1})/4 - (r^2\alpha_1)/4 + (x_1^2\gamma_1)/2 \\ &\quad + (r^2\beta_1)/4 + (y_1^2\beta_1)/2 + (r(\epsilon_{x_1} - r\alpha_1) \log(r^{-1}))/2 \\ &\quad + (r(\epsilon_{y_1} + r\beta_1) \log(r^{-1}))/2 \\ f_{2(I_{24})} &= (-3r\epsilon_{x_2})/4 - (3r\epsilon_{y_1})/4 + (r^2\alpha_2)/4 - (x_2^2\gamma_2)/2 \\ &\quad - (r^2\beta_1)/4 - (y_1^2\beta_1)/2 - (r(\epsilon_{x_2} - r\alpha_2) \log(r^{-1}))/2 \\ &\quad - (r(\epsilon_{y_1} + r\beta_1) \log(r^{-1}))/2 \end{aligned}$$

D. COEFFICIENT CALCULATION IN CASE 2

Here are the formulas for calculating the coefficients \mathcal{M} for actuators that can be categorized in *Case 2*:

.1. $r_i \leq r_1$

$$\mathcal{M} = (1/(2\pi))(((f_{2(I_1)}(r_2) - f_{2(I_1)}(r_1)) - f_{2n(I_1)}) + ((f_{2(I_2)}(r_4) - f_{2(I_2)}(r_2)) - f_{2n(I_2)}))$$

.2. $r_1 < r_i \leq r_2$

$$\mathcal{M} = (1/(2\pi))(((f_{1(I_1)}(r_i) - f_{1(I_1)}(r_1)) - f_{1n(I_1)}) + ((f_{2(I_1)}(r_2) - f_{2(I_1)}(r_i)) - f_{2n(I_1)}) + ((f_{2(I_2)}(r_4) - f_{2(I_2)}(r_2)) - f_{2n(I_2)}))$$

.3. $r_2 < r_i < r_4$

$$\mathcal{M} = (1/(2\pi))(((f_{1(I_2)}(r_i) - f_{1(I_2)}(r_2)) - f_{1n(I_2)}) + ((f_{2(I_2)}(r_4) - f_{2(I_2)}(r_i)) - f_{2n(I_2)}) + ((f_{1(I_1)}(r_2) - f_{1(I_1)}(r_1)) - f_{1n(I_1)}))$$

.4. $r_i \geq r_4$

$$\mathcal{M} = (1/(2\pi))(((f_{1(I_1)}(r_2) - f_{1(I_1)}(r_1)) - f_{1n(I_1)}) + ((f_{1(I_2)}(r_4) - f_{1(I_2)}(r_2)) - f_{1n(I_2)}))$$

A. Sub-functions of f_1

$$\begin{aligned} f_{1(I_1)} &= (r(\kappa_{x_1} + \kappa_{y_1} - r\alpha_1 + r\beta_1) \log(r_i))/2 \\ f_{1(I_2)} &= (r(-(\kappa_{x_2}) - \kappa_{y_2} + r\alpha_2 - r\beta_2) \log(r_i))/2 \end{aligned}$$

B. Sub-functions of f_2

$$\begin{aligned} f_{2(I_1)} &= (-3r\epsilon_{x_1})/4 - (3r\epsilon_{y_1})/4 + (r^2\alpha_1)/4 - (x_1^2\gamma_1)/2 \\ &\quad - (r^2\beta_1)/4 - (y_1^2\beta_1)/2 - (r(\epsilon_{x_1} - r\alpha_1) \log(r^{-1}))/2 \\ &\quad - (r(\epsilon_{y_1} + r\beta_1) \log(r^{-1}))/2 \end{aligned}$$

$$\begin{aligned} f_{2(I_2)} &= (3r\epsilon_{x_2})/4 + (3r\epsilon_{y_2})/4 - (r^2\alpha_2)/4 + (x_2^2\gamma_2)/2 \\ &\quad + (r^2\beta_2)/4 + (y_2^2\beta_2)/2 + (r(\epsilon_{x_2} - r\alpha_2) \log(r^{-1}))/2 \\ &\quad + (r(\epsilon_{y_2} + r\beta_2) \log(r^{-1}))/2 \end{aligned}$$

E. COEFFICIENT CALCULATION IN CASE 3

Here are the formulas for calculating the coefficients \mathcal{M} for actuators that can be categorized in *Case 3*:

.1. $r_i \leq r_{1e}$

$$\begin{aligned} \mathcal{M} &= (1/(2\pi))((f_{2(I_{11})}(r_1) - f_{2(I_{11})}(r_{1e})) - f_{2n(I_{11})}) \\ &\quad + (f_{2(I_{12})}(r_1) - f_{2(I_{12})}(r_{1e})) - f_{2n(I_{12})}) \\ &\quad + (f_{2(I_2)}(r_{4e}) - f_{2(I_2)}(r_1)) - f_{2n(I_2)} \\ &\quad + (f_{2(I_{31})}(r_4) - f_{2(I_{31})}(r_{4e})) - f_{2n(I_{31})}) \\ &\quad + (f_{2(I_{32})}(r_4) - f_{2(I_{32})}(r_{4e})) - f_{2n(I_{32})}) \end{aligned}$$

.2. $r_{1e} < r_i \leq r_1$

$$\begin{aligned} \mathcal{M} &= (1/(2\pi))((f_{1(I_{11})}(r_i) - f_{1(I_{11})}(r_{1e})) - f_{1n(I_{11})}) \\ &\quad + (f_{1(I_{12})}(r_i) - f_{1(I_{12})}(r_{1e})) - f_{1n(I_{12})}) \\ &\quad + (f_{2(I_{11})}(r_1) - f_{2(I_{11})}(r_i)) - f_{2n(I_{11})}) \\ &\quad + (f_{2(I_{12})}(r_1) - f_{2(I_{12})}(r_i)) - f_{2n(I_{12})}) \\ &\quad + (f_{2(I_2)}(r_{4e}) - f_{2(I_2)}(r_1)) - f_{2n(I_2)} \\ &\quad + (f_{2(I_{31})}(r_4) - f_{2(I_{31})}(r_{4e})) - f_{2n(I_{31})}) \\ &\quad + (f_{2(I_{32})}(r_4) - f_{2(I_{32})}(r_{4e})) - f_{2n(I_{32})}) \end{aligned}$$

.3. $r_1 < r_i \leq r_{4e}$

$$\begin{aligned} \mathcal{M} &= (1/(2\pi))((f_{1(I_2)}(r_i) - f_{1(I_2)}(r_1)) - f_{1n(I_2)}) \\ &\quad + (f_{2(I_2)}(r_{4e}) - f_{2(I_2)}(r_i)) - f_{2n(I_2)} \\ &\quad + (f_{1(I_{11})}(r_1) - f_{1(I_{11})}(r_{1e})) - f_{1n(I_{11})}) \\ &\quad + (f_{1(I_{12})}(r_1) - f_{1(I_{12})}(r_{1e})) - f_{1n(I_{12})}) \\ &\quad + (f_{2(I_{31})}(r_4) - f_{2(I_{31})}(r_{4e})) - f_{2n(I_{31})}) \\ &\quad + (f_{2(I_{32})}(r_4) - f_{2(I_{32})}(r_{4e})) - f_{2n(I_{32})}) \end{aligned}$$

.4. $r_{4e} < r_i < r_4$

$$\begin{aligned} \mathcal{M} &= (1/(2\pi))((f_{1(I_{31})}(r_i) - f_{1(I_{31})}(r_{4e})) - f_{1n(I_{31})}) \\ &\quad + (f_{1(I_{32})}(r_i) - f_{1(I_{32})}(r_{4e})) - f_{1n(I_{32})}) \\ &\quad + (f_{2(I_{31})}(r_4) - f_{2(I_{31})}(r_i)) - f_{2n(I_{31})}) \\ &\quad + (f_{2(I_{32})}(r_4) - f_{2(I_{32})}(r_i)) - f_{2n(I_{32})}) \\ &\quad + (f_{1(I_{11})}(r_1) - f_{1(I_{11})}(r_{1e})) - f_{1n(I_{11})}) \\ &\quad + (f_{1(I_{12})}(r_1) - f_{1(I_{12})}(r_{1e})) - f_{1n(I_{12})}) \\ &\quad + (f_{1(I_2)}(r_{4e}) - f_{1(I_2)}(r_1)) - f_{1n(I_2)} \end{aligned}$$

.5. $r_i \geq r_4$

$$\begin{aligned} \mathcal{M} = & (1/(2\pi))((f_{1(I_{11})}(r_1) - f_{1(I_{11})}(r_{1e})) - f_{1n(I_{11})}) \\ & + (f_{1(I_{12})}(r_1) - f_{1(I_{12})}(r_{1e})) - f_{1n(I_{12})}) \\ & + (f_{1(I_2)}(r_{4e}) - f_{1(I_2)}(r_1)) - f_{1n(I_2)} \\ & + (f_{1(I_{31})}(r_4) - f_{1(I_{31})}(r_{4e})) - f_{1n(I_{31})} \\ & + (f_{1(I_{32})}(r_4) - f_{1(I_{32})}(r_{4e})) - f_{1n(I_{32})}) \end{aligned}$$

A. Sub-functions of f_1

$$\begin{aligned} f_{1(I_{11})} &= -((-r\kappa_{x_1} + r^2\alpha_1) \log(r_i))/2 \\ f_{1(I_{12})} &= -((-r\kappa_{x_1} + r^2\alpha_1) \log(r_i))/2 \\ f_{1(I_2)} &= (r(\kappa_{y_1} - \kappa_{y_2} + r\beta_1 - r\beta_2) \log(r_i))/2 \\ f_{1(I_{31})} &= (r(-(\kappa_{x_2}) - \kappa_{y_2} + r\alpha_2 - r\beta_2) \log(r_i))/2 \\ f_{1(I_{32})} &= (r(\kappa_{x_2} + \kappa_{y_1} - r\alpha_2 + r\beta_1) \log(r_i))/2 \end{aligned}$$

B. Sub-functions of f_2

$$\begin{aligned} f_{2(I_{11})} &= (-2x_1^2\gamma_1 + r^2\alpha_1(1 + 2\log(r^{-1})) \\ &\quad - r\kappa_{x_1}(3 + 2\log(r^{-1}))) / 4 \\ f_{2(I_{12})} &= (-2x_1^2\gamma_1 + r^2\alpha_1(1 + 2\log(r^{-1})) \\ &\quad - r\kappa_{x_1}(3 + 2\log(r^{-1}))) / 4 \end{aligned}$$

$$\begin{aligned} f_{2(I_2)} &= (-r(\kappa_{y_1} - \kappa_{y_2})(3 + 2\log(r^{-1})) - \beta_1(r^2 + 2y_1^2 \\ &\quad + 2r^2\log(r^{-1})) + \beta_2(r^2 + 2y_2^2 + 2r^2\log(r^{-1}))) / 4 \end{aligned}$$

$$\begin{aligned} f_{2(I_{31})} &= (3r\epsilon_{x_2}) / 4 + (3r\epsilon_{y_2}) / 4 - (r^2\alpha_2) / 4 + (x_2^2\gamma_2) / 2 \\ &\quad + (r^2\beta_2) / 4 + (y_2^2\beta_2) / 2 + (r(\epsilon_{x_2} - r\alpha_2) \log(r^{-1})) / 2 \\ &\quad + (r(\epsilon_{y_2} + r\beta_2) \log(r^{-1})) / 2 \end{aligned}$$

$$\begin{aligned} f_{2(I_{32})} &= (-3r\epsilon_{x_2}) / 4 - (3r\epsilon_{y_1}) / 4 + (r^2\alpha_2) / 4 - (x_2^2\gamma_2) / 2 \\ &\quad - (r^2\beta_1) / 4 - (y_1^2\beta_1) / 2 - (r(\epsilon_{x_2} - r\alpha_2) \log(r^{-1})) / 2 \\ &\quad - (r(\epsilon_{y_1} + r\beta_1) \log(r^{-1})) / 2 \end{aligned}$$

F. COEFFICIENT CALCULATION IN CASE 4

Here are the formulas for calculating the coefficients \mathcal{M} for actuators that can be categorized in *Case 4*:

.1. $r_i \leq r_1$

$$\begin{aligned} \mathcal{M} = & (1/(2\pi))(((f_{2(I_1)}(r_3) - f_{2(I_1)}(r_1)) - f_{2n(I_1)}) \\ & + ((f_{2(I_2)}(r_2) - f_{2(I_2)}(r_3)) - f_{2n(I_2)}) \\ & + ((f_{2(I_3)}(r_4) - f_{2(I_3)}(r_2)) - f_{2n(I_3)})) \end{aligned}$$

.2. $r_1 < r_i \leq r_3$

$$\begin{aligned} \mathcal{M} = & (1/(2\pi))(((f_{1(I_1)}(r_i) - f_{1(I_1)}(r_1)) - f_{1n(I_1)}) \\ & + ((f_{2(I_1)}(r_3) - f_{2(I_1)}(r_i)) - f_{2n(I_1)}) \\ & + ((f_{2(I_2)}(r_2) - f_{2(I_2)}(r_3)) - f_{2n(I_2)}) \\ & + ((f_{2(I_3)}(r_4) - f_{2(I_3)}(r_2)) - f_{2n(I_3)})) \end{aligned}$$

.3. $r_3 < r_i \leq r_2$

$$\begin{aligned} \mathcal{M} = & (1/(2\pi))(((f_{1(I_2)}(r_i) - f_{1(I_2)}(r_3)) - f_{1n(I_2)}) \\ & + ((f_{2(I_2)}(r_2) - f_{2(I_2)}(r_i)) - f_{2n(I_2)}) \\ & + ((f_{1(I_1)}(r_3) - f_{1(I_1)}(r_1)) - f_{1n(I_1)}) \\ & + ((f_{2(I_3)}(r_4) - f_{2(I_3)}(r_2)) - f_{2n(I_3)})) \end{aligned}$$

.4. $r_2 < r_i < r_4$

$$\begin{aligned} \mathcal{M} = & (1/(2\pi))(((f_{1(I_3)}(r_i) - f_{1(I_3)}(r_2)) - f_{1n(I_3)}) \\ & + ((f_{2(I_3)}(r_4) - f_{2(I_3)}(r_i)) - f_{2n(I_3)}) \\ & + ((f_{1(I_1)}(r_3) - f_{1(I_1)}(r_1)) - f_{1n(I_1)}) \\ & + ((f_{1(I_2)}(r_2) - f_{1(I_2)}(r_3)) - f_{1n(I_2)})) \end{aligned}$$

.5. $r_i \geq r_4$

$$\begin{aligned} \mathcal{M} = & (1/(2\pi))(((f_{1(I_1)}(r_3) - f_{1(I_1)}(r_1)) - f_{1n(I_1)}) \\ & + ((f_{1(I_2)}(r_2) - f_{1(I_2)}(r_3)) - f_{1n(I_2)}) \\ & + ((f_{1(I_3)}(r_4) - f_{1(I_3)}(r_2)) - f_{1n(I_3)})) \end{aligned}$$

A. Sub-functions of f_1

$$\begin{aligned} f_{1(I_1)} &= (r(\kappa_{x_1} + \kappa_{y_1} - r\alpha_1 + r\beta_1) \log(r_i)) / 2 \\ f_{1(I_2)} &= (r(\kappa_{x_1} - \kappa_{x_2} - r\alpha_1 + r\alpha_2) \log(r_i)) / 2 \\ f_{1(I_3)} &= (r(-(\kappa_{x_2}) - \kappa_{y_2} + r\alpha_2 - r\beta_2) \log(r_i)) / 2 \end{aligned}$$

B. Sub-functions of f_2

$$\begin{aligned} f_{2(I_1)} &= (-3r\epsilon_{x_1}) / 4 - (3r\epsilon_{y_1}) / 4 + (r^2\alpha_1) / 4 - (x_1^2\gamma_1) / 2 \\ &\quad - (r^2\beta_1) / 4 - (y_1^2\beta_1) / 2 - (r(\epsilon_{x_1} - r\alpha_1) \log(r^{-1})) / 2 \\ &\quad - (r(\epsilon_{y_1} + r\beta_1) \log(r^{-1})) / 2 \end{aligned}$$

$$\begin{aligned} f_{2(I_2)} &= (-3r\epsilon_{x_1}) / 4 + (3r\epsilon_{x_2}) / 4 + (r^2\alpha_1) / 4 - (r^2\alpha_2) / 4 \\ &\quad - (x_1^2\gamma_1) / 2 + (x_2^2\gamma_2) / 2 - (r(\epsilon_{x_1} - r\alpha_1) \log(r^{-1})) / 2 \\ &\quad + (r(\epsilon_{x_2} - r\alpha_2) \log(r^{-1})) / 2 \end{aligned}$$

$$\begin{aligned} f_{2(I_3)} &= (3r\epsilon_{x_2}) / 4 + (3r\epsilon_{y_2}) / 4 - (r^2\alpha_2) / 4 + (x_2^2\gamma_2) / 2 \\ &\quad + (r^2\beta_2) / 4 + (y_2^2\beta_2) / 2 + (r(\epsilon_{x_2} - r\alpha_2) \log(r^{-1})) / 2 \\ &\quad + (r(\epsilon_{y_2} + r\beta_2) \log(r^{-1})) / 2 \end{aligned}$$

G. COEFFICIENT CALCULATION IN CASE 5

Here are the formulas for calculating the coefficients \mathcal{M} for actuators that can be categorized in *Case 5*:

.1. $r_i \leq r_1$

$$\begin{aligned} \mathcal{M} = & (1/(2\pi))(((f_{2(I_1)}(r_2) - f_{2(I_1)}(r_1)) - f_{2n(I_1)}) \\ & + ((f_{2(I_2)}(r_3) - f_{2(I_2)}(r_2)) - f_{2n(I_2)}) \\ & + ((f_{2(I_3)}(r_4) - f_{2(I_3)}(r_3)) - f_{2n(I_3)})) \end{aligned}$$

.2. $r_1 < r_i \leq r_2$

$$\begin{aligned} \mathcal{M} = & (1/(2\pi))(((f_{1(I_1)}(r_i) - f_{1(I_1)}(r_1)) - f_{1n(I_1)}) \\ & + ((f_{2(I_1)}(r_2) - f_{2(I_1)}(r_i)) - f_{2n(I_1)}) \\ & + ((f_{2(I_2)}(r_3) - f_{2(I_2)}(r_2)) - f_{2n(I_2)}) \\ & + ((f_{2(I_3)}(r_4) - f_{2(I_3)}(r_3)) - f_{2n(I_3)})) \end{aligned}$$

3. $r_2 < r_i \leq r_3$

$$\begin{aligned} \mathcal{M} = & (1/(2\pi))(((f_{1(l_2)}(r_i) - f_{1(l_2)}(r_2)) - f_{1n(l_2)}) \\ & + ((f_{2(l_2)}(r_3) - f_{2(l_2)}(r_i)) - f_{2n(l_2)}) \\ & + ((f_{1(l_1)}(r_2) - f_{1(l_1)}(r_1)) - f_{1n(l_1)}) \\ & + ((f_{2(l_3)}(r_4) - f_{2(l_3)}(r_3)) - f_{2n(l_3)}) \end{aligned}$$

4. $r_3 < r_i < r_4$

$$\begin{aligned} \mathcal{M} = & (1/(2\pi))(((f_{1(l_3)}(r_i) - f_{1(l_3)}(r_3)) - f_{1n(l_3)}) \\ & + ((f_{2(l_3)}(r_4) - f_{2(l_3)}(r_i)) - f_{2n(l_3)}) \\ & + ((f_{1(l_1)}(r_2) - f_{1(l_1)}(r_1)) - f_{1n(l_1)}) \\ & + ((f_{1(l_2)}(r_3) - f_{1(l_2)}(r_2)) - f_{1n(l_2)}) \end{aligned}$$

5. $r_i \geq r_4$

$$\begin{aligned} \mathcal{M} = & (1/(2\pi))(((f_{1(l_1)}(r_2) - f_{1(l_1)}(r_1)) - f_{1n(l_1)}) \\ & + ((f_{1(l_2)}(r_3) - f_{1(l_2)}(r_2)) - f_{1n(l_2)}) \\ & + ((f_{1(l_3)}(r_4) - f_{1(l_3)}(r_3)) - f_{1n(l_3)}) \end{aligned}$$

A. Sub-functions of f_1

$$\begin{aligned} f_{1(l_1)} &= (r(\kappa_{x_1} + \kappa_{y_1} - r\alpha_1 + r\beta_1) \log(r_i))/2 \\ f_{1(l_2)} &= (r(\kappa_{y_1} - \kappa_{y_2} + r\beta_1 - r\beta_2) \log(r_i))/2 \\ f_{1(l_3)} &= (r(-(\kappa_{x_2}) - \kappa_{y_2} + r\alpha_2 - r\beta_2) \log(r_i))/2 \end{aligned}$$

B. Sub-functions of f_2

$$\begin{aligned} f_{2(l_1)} &= (-3r\epsilon_{x_1})/4 - (3r\epsilon_{y_1})/4 + (r^2\alpha_1)/4 - (x_1^2\gamma_1)/2 \\ & - (r^2\beta_1)/4 - (y_1^2\beta_1)/2 - (r(\epsilon_{x_1} - r\alpha_1) \log(r^{-1}))/2 \\ & - (r(\epsilon_{y_1} + r\beta_1) \log(r^{-1}))/2 \\ f_{2(l_2)} &= -(r(\kappa_{y_1} - \kappa_{y_2})(3 + 2 \log(r^{-1}))) - \beta_1(r^2 + 2y_1^2) \\ & + 2r^2 \log(r^{-1}) + \beta_2(r^2 + 2y_2^2 + 2r^2 \log(r^{-1}))/4 \\ f_{2(l_3)} &= (3r\epsilon_{x_2})/4 + (3r\epsilon_{y_2})/4 - (r^2\alpha_2)/4 + (x_2^2\gamma_2)/2 \\ & + (r^2\beta_2)/4 + (y_2^2\beta_2)/2 + (r(\epsilon_{x_2} - r\alpha_2) \log(r^{-1}))/2 \\ & + (r(\epsilon_{y_2} + r\beta_2) \log(r^{-1}))/2 \end{aligned}$$

FUNDING

This work was co-funded through a Marie Skłodowska-Curie COFUND (DSSC 754315).

ACKNOWLEDGMENTS

The authors thank Dr. M. Acuautila and Prof. B. Noheda of the University of Groningen, and Dr. S.N.R. Kazmi, M. Eggens and H. Smit of the Netherlands Institute for Space Research for their valuable input on the Hysteretic Deformable Mirror project. In addition, we would like to thank the Center for Information Technology of the University of Groningen for their support and for providing access to the Peregrine high performance computing cluster.

DISCLOSURE

The authors declare no conflicts of interest.

REFERENCES

1. R. J. Zawadzki, S. M. Jones, S. S. Olivier, M. Zhao, B. A. Bower, J. A. Izatt, S. Choi, S. Laut, and J. S. Werner, "Adaptive-optics optical coherence tomography for high-resolution and high-speed 3d retinal in vivo imaging," *Opt. Express* **13**, 8532–8546 (2005).
2. W. J. Shain, N. A. Vickers, B. B. Goldberg, T. Bifano, and J. Mertz, "Extended depth-of-field microscopy with a high-speed deformable mirror," *Opt. Lett.* **42**, 995–998 (2017).
3. M. J. Booth, "Adaptive optics in microscopy," *Phil. Trans. R. Soc. A.* **365**, 2829–2843 (2007).
4. E. J. Fernández, I. Iglesias, and P. Artal, "Closed-loop adaptive optics in the human eye," *Opt. Lett.* **26**, 746–748 (2001).
5. G. Vdovin and V. Kiyko, "Intracavity control of a 200-W continuous-wave Nd:YAG laser by a micromachined deformable mirror," *Opt. Lett.* **26**, 798–800 (2001).
6. John W. Hardy, *Adaptive Optics for Astronomical Telescopes* (Oxford Series in Optical and Imaging Sciences, Oxford University Press, 1998).
7. T. Sato, H. Ishida, and O. Ikeda, "Adaptive PVDF piezoelectric deformable mirror system," *Appl. Opt.* **19**, 1430–1434 (1980).
8. K. L. Wlodarczyk, E. Bryce, N. Schwartz, M. Strachan, D. Hutson, R. R. J. Maier, D. Atkinson, S. Beard, T. Baillie, P. Parr-Burman, K. Kirk, and D. P. Hand, "Scalable stacked array piezoelectric deformable mirror for astronomy and laser processing applications," *Rev. Sci. Instruments* **85**, 024502 (2014).
9. S. A. Cornelissen, A. L. Hartzell, J. B. Stewart, T. G. Bifano, and P. A. Bierden, "MEMS deformable mirrors for astronomical adaptive optics," in *Adaptive Optics Systems II*, vol. 7736 B. L. Ellerbroek, M. Hart, N. Hubin, and P. L. Wizinowich, eds., International Society for Optics and Photonics (SPIE, 2010), pp. 898 – 907.
10. G. Vdovin and M. Loktev, "Deformable mirror with thermal actuators," *Opt. Lett.* **27**, 677–679 (2002).
11. L. Huang, X. Ma, M. Gong, and Q. Bian, "Experimental investigation of the deformable mirror with bidirectional thermal actuators," *Opt. Express* **23**, 17520–17530 (2015).
12. R. G. Gilbertson and J. D. Busch, "A survey of micro-actuator technologies for future spacecraft missions," *Journal of The British Interplanetary Society* **49**, 129–138 (1996).
13. R. Biasi, D. Gallieni, P. Salinari, A. Riccardi, and P. Mantegazza, "Contactless thin adaptive mirror technology: past, present, and future," in *Adaptive Optics Systems II*, vol. 7736 B. L. Ellerbroek, M. Hart, N. Hubin, and P. L. Wizinowich, eds., International Society for Optics and Photonics (SPIE, 2010), pp. 872 – 885.
14. P.-Y. Mader, "Overview of deformable mirror technologies for adaptive optics and astronomy," in *Adaptive Optics Systems III*, vol. 8447 B. L. Ellerbroek, E. Marchetti, and J.-P. Véran, eds., International Society for Optics and Photonics (SPIE, 2012), pp. 22 – 39.
15. The LUVVOIR Team, "The LUVVOIR Mission Concept Study Final Report," arXiv preprint, arXiv: 1912.06219 (2019).
16. R. H. Freeman and J. E. Pearson, "Deformable mirrors for all seasons and reasons," *Appl. Opt.* **21**, 580–588 (1982).
17. Riaud, P., "New high-density deformable mirrors for high-contrast imaging," *A & A* **545**, A25 (2012).
18. R. Huisman, M. Bruijn, S. Damerio, M. Eggens, S.N.R. Kazmi, A.E.M. Schmerbauch, H. Smit, M.A. Vasquez-Beltran, E. van der Veer, M. Acuautila, B. Jayawardhana, and B. Noheda, "High pixel number deformable mirror concept utilizing piezoelectric hysteresis for stable shape configurations," arXiv preprint, arXiv:2008.09338 (2020).
19. M. A. Vasquez-Beltran, B. Jayawardhana, and R. Peletier, "Recursive Algorithm for the Control of Output Remnant of Preisach Hysteresis Operator," *IEEE Control. Syst. Lett.* **5**, 1061–1066 (2021).
20. E. Scott Clafflin and Noah Bareket, "Configuring an electrostatic membrane mirror by least-squares fitting with analytically derived influence functions," *J. Opt. Soc. Am. A* **3**, pp. 1833–1839 (1986).
21. V. Lakshminarayanan and A. Fleck, "Zernike polynomials: A guide," *Journal of Modern Optics - J MOD OPTIC*. **58**, 1678–1678 (2011).
22. L. Huang, C. Rao, and W. Jiang, "Modified gaussian influence function of deformable mirror actuators," *Opt. Express* **16**, 108–114 (2008).

23. R. K. Tyson, *Adaptive Optics Engineering Handbook* (CRC Press, 1999).
24. R. K. Tyson and B. W. Frazier, *Field Guide to Adaptive Optics* (SPIE Press, 2004).
25. R.F.M.M. Hamelinck, "Adaptive deformable mirror : based on electro-magnetic actuators," Eindhoven : Technische Universiteit Eindhoven (2010).
26. R. P. Grosso and M. Yellin, "The membrane mirror as an adaptive optical element," *J. Opt. Soc. Am.* 67 pp. 399–406 (1977).
27. L. Arnold, "Optimized axial support topologies for thin telescope mirrors," *Optical Engineering* pp. 567–574 (1995).
28. S.K. Ravensbergen, R.F.M.M. Hamelinck, P.C.J.N. Rosielle and M. Steinbuch, "Deformable mirrors: Design fundamentals for force actuation of continuous facesheets," *SPIE Optics & Photonics; Advanced Wavefront Control: Methods, Devices, and Applications VII* **7466**, 74660G (2009).
29. L. Arnold, "Uniform-load and actuator influence functions of a thin or thick annular mirror: application to active mirror support optimization," *Appl. Opt.* **35**, 1095–1106 (1996).
30. L. Arnold, "Influence functions of a thin shallow meniscus-shaped mirror," *Appl. Opt.* **36**, 2019–2028 (1997).
31. K. Bush, D. German, B. Klemme, A. Marrs and M. Schoen, "Electrostatic membrane deformable mirror wavefront control systems: design and analysis," *SPIE Optics & Photonics; Advanced Wavefront Control: Methods, Devices, and Applications II* **5553**, 28–38 (2004).
32. A. Menikoff, "Actuator influence functions of active mirrors," *Appl. Opt.* 30 pp. 833–838 (1991).
33. T. Ruppel, "Modeling and control of deformable membrane mirrors," *Adapt. Opt. Prog.* (2012).
34. P. M. Morse and H. Feshbach, *Methods of Theoretical Physics, Part II* (McGraw-Hill, New York, 1953).
35. B. Jayawardhana, M. A. Vasquez-Beltran, W. J. van de Beek, C. de Jonge, M. Acuautla, S. Damerio, R. Peletier, B. Noheda, and R. Huisman, "Modeling and Analysis of Butterfly Loops via Preisach Operators and its Application in a Piezoelectric Material," in *2018 IEEE Conference on Decision and Control (CDC)*, (2018), pp. 6894–6899.
36. M. A. Vasquez-Beltran, B. Jayawardhana, and R. Peletier, "Asymptotic Stability Analysis of Lur'e Systems With Butterfly Hysteresis Nonlinearities," *IEEE Control. Syst. Lett.* **4**, 349–354 (2020).