

The application of σ -LFSR in Key-Dependent Feedback Configuration for Word-Oriented Stream Ciphers

Subrata Nandi^{*1}[0000-0001-7140-0608], Srinivasan
Krishnaswamy²[0000-0001-9714-7399], Behrouz Zolfaghari³[0000-0001-6691-0988],
and Pinaki Mitra⁴[0000-0002-8254-8234]

¹ * Corresponding author, CSE Department, Indian Institute of Technology
Guwahati, Gwa 781039, India subrata.nandi@iitg.ac.in

² EEE Department, Indian Institute of Technology Guwahati, Gwa 781039, India
srinikris@iitg.ac.in

³ CSE Department, Indian Institute of Technology Guwahati, Gwa 781039, India
zolfaghari@iitg.ac.in

⁴ CSE Department, Indian Institute of Technology Guwahati, Gwa 781039, India
pinaki@iitg.ac.in

Abstract. In this paper, we propose and evaluate a method for generating key-dependent feedback configurations (KDFC) for σ -LFSRs. σ -LFSRs with such configurations can be applied to any stream cipher that uses a word-based LFSR. Here, a configuration generation algorithm uses the secret key(K) and the initialization vector (IV) to generate a feedback configuration. We have mathematically analysed the feedback configurations generated by this method. As a test case, we have applied this method on SNOW 2.0 and have studied its impact on resistance to various attacks. Further, we have also tested the generated keystream for randomness and have briefly described its implementation and the challenges involved in the same.

Keywords: Stream Cipher · σ -LFSR · Key-Dependent Feedback Configuration · Primitive Polynomial · Algebraic Attack.

1 Introduction

Stream ciphers are used in a variety of applications [ANA16, PBC19]. LFSRs (Linear Feedback Shift Register) are widely used as building blocks in stream ciphers because of their simple construction and easy implementation.

Word based LFSRs were introduced to efficiently use the structure of modern word based processors ([ros, BBC⁺08, Xt11, EJMY19]). Such LFSRs are used in a variety of stream ciphers, most notably in the SNOW series of stream ciphers. A σ -LFSR is a word based LFSR configuration that was introduced in [ZHH07]. An important property of this configuration is that there are multiple feedback functions corresponding to a given characteristic polynomial of the state

transition matrix([KP11]). The number of such configurations was conjectured in ([ZHH07]). This conjecture was constructively proved in [KP11]

The knowledge of the feedback function plays a critical role in most attacks on LFSR based stream ciphers. These include algebraic attacks, correlation attacks and distinguishing attacks ([BG05, WBDC03, NW06, LLP08, ZXM]). Therefore, hiding the feedback function of the LFSR could potentially increase the security of such schemes. In this paper we try doing this by making the feedback function dependent on the secret key. The resulting configuration is called the σ -KDFC (Key Dependent Feedback Configuration). The proposed method for obtaining the feedback function from the secret key utilizes the algorithm given in [KP11, KP14]. The feedback gains thus obtained are highly non-linear functions of the secret key. Further, the number of iterations in this algorithm can be adjusted depending on the available computing power. As an example, we study the interconnection of the σ -KDFC with the finite state machine (FSM) of SNOW-2. We use empirical tests to verify the randomness of the keystream generated by this scheme. Further, we analyse the scheme for security against various kinds of attacks.

In this paper, \mathbb{F}_{2^n} denotes a finite field of cardinality 2^n . \mathbb{F}_2^n denotes an n -dimensional vector space over \mathbb{F}_2 . The i^{th} row and j^{th} column of a matrix $M \in \mathbb{F}^{n \times n}$ are denoted by $M[i, :]$ and $M[:, j]$ respectively. $M[i, j]$ denotes the (i, j) -th entry of the matrix M . The minor of $M[i, j]$ is denoted by $\mu(M[i, j])$. \oplus and $+$ are used interchangeably to represent addition over \mathbb{F}_2 .

The rest of this paper is organized as follows. Section 2 introduces LFSRs, σ -LFSRs and some related concepts. Section 3 examines σ -KDFC and its time complexity. Section 4 presents the mathematical analysis on the algebraic degree of the parameters of the feedback function generated by σ -KDFC. Section 5 discusses the the interconnection of σ -KDFC with the FSM of SNOW and its security against various cryptographic attacks . Section 6 concludes the paper.

2 LFSRs and σ -LFSRs

An LFSR is an electronic circuit that implements a linear recurring relation (LRR) of the form $x_{n+b} = a_{b-1}x_{n+b-1} + \dots + a_0x_n$. It consists of a shift register with b flip-flops and a linear feedback function which is typically implemented using XOR gates. The integer b is called the length of the LFSR. The characteristic polynomial of an LFSR is a monic polynomial with the same coefficients as the LRR implemented by it. For example, the characteristic polynomial of an LFSR which implements the LRR given above is $x^b + a_{b-1}x^{b-1} + \dots + a_0$. The period of the sequence generated by an LFSR of length b is at most $2^b - 1$. Further, an LFSR generates a maximum-period sequence if its characteristic polynomial is primitive [AG98]. The state vector of an LFSR at any time instant is a vector whose entries are the outputs of the delay blocks at tha time instant i.e $\mathbf{x}_n = [x_n, x_{n+1}, \dots, x_{n+b-1}]$. Two consecutive state vectors are related by the equation $\mathbf{x}_{n+1} = \mathbf{x}_n P_f$ where P_f is the companion matrix of the characteristic polynomial.

In order to efficiently work with word based processors various word based LFSR designs have been proposed [CHM⁺04,KTS17,EJ00,BBC⁺08,EJ02,EJMY19,ros]. These designs use multi input multi output delay blocks. One such design is the σ -LFSR shown in Figure 1. Here, the feedback gains are matrices and the implemented linear recurring relation is of the form

$$\mathbf{x}_{\mathbf{n}+\mathbf{b}} = \mathbf{x}_{\mathbf{n}+\mathbf{b}-1}B_{\mathbf{n}+\mathbf{b}-1} + \mathbf{x}_{\mathbf{n}+\mathbf{b}-2}B_{\mathbf{n}+\mathbf{b}-2} + \cdots + \mathbf{x}_{\mathbf{n}}B_0 \quad (1)$$

where each $\mathbf{x}_i \in \mathbb{F}_2^m$ and $B_i \in \mathbb{F}_2^{m \times m}$. Here, each delay block has m -inputs and m -outputs and the σ -LFSR generates a sequence of vectors in \mathbb{F}_2^m

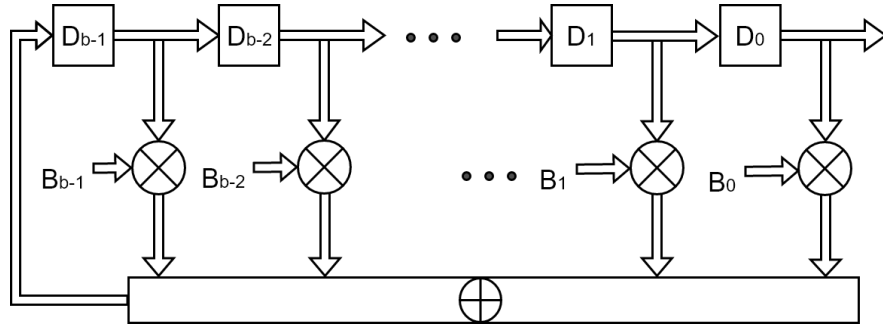

Fig. 1. Block diagram of σ -LFSR

The matrices B_0, B_1, \dots, B_{b-1} are referred to as the gain matrices of the σ -LFSR and the following matrix is defined as its configuration matrix.

$$C = \begin{bmatrix} 0 & I & 0 & \cdots & 0 \\ 0 & 0 & I & \cdots & 0 \\ \vdots & \vdots & \vdots & \cdots & \vdots \\ 0 & 0 & 0 & \cdots & I \\ B_0 & B_1 & B_2 & \cdots & B_{b-1} \end{bmatrix} \in \mathbb{F}_2^{mb \times mb} \quad (2)$$

where $0, I \in \mathbb{F}_2^{m \times m}$ are the all-zero and identity matrices respectively. We shall refer to the structure of this matrix as the M -companion structure. The characteristic polynomial of this configuration matrix is known as the characteristic polynomial of the σ -LFSR.

If $\mathbf{x}_{\mathbf{n}}$ is the output of the σ -LFSR at the n -th time instant, then its state vector at that time instant is defined as $\hat{\mathbf{x}}_{\mathbf{n}} = [\mathbf{x}_{\mathbf{n}}, \mathbf{x}_{\mathbf{n}+1}, \dots, \mathbf{x}_{\mathbf{n}+\mathbf{b}-1}]$. This vector is got by stacking the outputs of all the delay blocks at the n -th time instant. Two consecutive state vectors are related by the following equation:

$$\hat{\mathbf{x}}_{\mathbf{n}+1} = \hat{\mathbf{x}}_{\mathbf{n}}C^T \quad (3)$$

In the case of σ -LFSRs, there are many possible feedback configurations having the same characteristic polynomial. For a given primitive polynomial, the number of such configurations was conjectured in [ZHH07] to be the following,

$$N_P = \frac{|GL(m, \mathbb{F}_2)|}{2^m - 1} \times \frac{\phi(2^{mb} - 1)}{mb} \times 2^{m(m-1)(b-1)} \quad (4)$$

where $|GL(m, \mathbb{F}_2)|$ is the general linear group of non-singular matrices $\in \mathbb{F}_2^{m \times m}$, and ϕ represents Euler's totient. This conjecture has been proved in [KP14]. Moreover, this inductive proof is constructive and gives an algorithm for calculating such feedback functions.

In the following section, we shall use the algorithm given in [KP14] to develop a key dependent feedback configuration for the σ -LFSR.

3 σ -KDFC

Stream ciphers, like the SNOW series of ciphers, use word based LFSRs along with an FSM module. The feedback configuration of the LFSR in such schemes is publicly known. This feedback relation is used in most attacks on such schemes [BG05, NW06, AE09, ZXM]. Therefore, the security of such schemes could potentially increase if the feedback function is made key dependent.

Before proceeding to our construction of a key dependent feedback configuration, we briefly describe the algorithm given in [KP14] which generates feedback configurations for σ -LFSRs with a given characteristic polynomial. Given a primitive polynomial $p_{mb}(x)$ having degree mb , the algorithm for calculating a feedback configuration for a σ -LFSR with b m -input m -output delay blocks is as follows:

Algorithm 1 Configuration Matrix Generation

1. Initialize Y with a full rank matrix in $\mathbb{F}_2^{m \times m}$.
2. Choose $mb - m - 1$ primitive polynomials $p_m(x), p_{m+1}(x), \dots, p_{mb-1}(x)$ having degrees $m, m+1, \dots, mb-1$ respectively. (Note that the polynomial $p_{mb}(x)$ is given). Let $A_m, A_{m+1}, \dots, A_{mb}$ be the companion matrices of $p_m(x), p_{m+1}(x), \dots, p_{mb}(x)$ respectively.
3. For $i = 1$ to $mb - m$ update Y as follows
 - (a) Let ℓ be the unique integer less or equal to m which is equivalent to $i \bmod m$. Find a polynomial $f(x)$ such that $Y[\ell \bmod m, :] A_{m+i-1} = (0, 0, \dots, 1) \in \mathbb{F}_2^{m+i-1}$ and update Y as follows

$$Y = Y * A_{m+i-1}$$

- (b) For all $t \neq \ell \bmod m$, $Y[t, :] = (Y[t, :], d_t)$ where d_t is an element of \mathbb{F}_2 . (In this step all the rows of Y , except the one which is equivalent to $i \bmod m$, are appended with random boolean numbers and their lengths are increased by 1.)
 - (c) If $t = \ell$, $Y[t, :] = (0, 0, \dots, 1) \in \mathbb{F}_2^{m+i}$.
(At the end of each iteration, an extra column is added to Y till $Y \in \mathbb{F}_2^{m \times mb}$.)
4. Construct the following matrix Q

$$\cdot Q \leftarrow \begin{bmatrix} Y[0 :,] \\ Y[1 :,] \\ \vdots \\ Y[m-1 :,] \\ Y[0 :,] \times P_{mb} \\ Y[1 :,] \times P_{mb} \\ \vdots \\ Y[m-1 :,] \times P_{mb} \\ \vdots \\ Y[0 :,] \times (P_{mb})^{b-1} \\ Y[1 :,] \times (P_{mb})^{b-1} \\ \vdots \\ Y[m-1 :,] \times (P_{mb})^{b-1} \end{bmatrix} \in \mathbb{F}_2^{mb \times mb}$$

5. $C = Q \times P_{mb} \times Q^{-1}$
-

The matrix C generated in the above algorithm is the configuration matrix of a σ -LFSR with characteristic polynomial $p_{mb}(x)$. As can be seen from Equation 2, the last m rows of this matrix contain the feedback gain matrices. Each set of choices for the d_t s and the initial full rank matrix result in a different feedback configuration.

In Step 3a, the coefficients of the polynomial $f(x)$ can be calculated by solving the linear equation $y \times K_t = (0, 0, \dots, 1) \in \mathbb{F}_2^{m+i-1}$ for y , where K_t is given by

$$K_i = \begin{bmatrix} Y[\ell, :] \\ Y[\ell, :]A_{m+i-1} \\ \vdots \\ Y[\ell, :]A_{m+i-1}^{m+i-2} \end{bmatrix}$$

In other words $f(x) = y(1) + y(2)x + \dots + y(m+i-1)x^{m+i-2}$, where $y(j)$ is the j -th entry of the vector y .

Note that in every iteration of Step 3 in Algorithm 1, $m-1$ random numbers are appended to the rows of the matrix Y . In the proposed scheme, some of these numbers are derived from the secret key. As a consequence, the derived feedback configuration is dependent on the secret key. We now proceed to look at this configuration in detail.

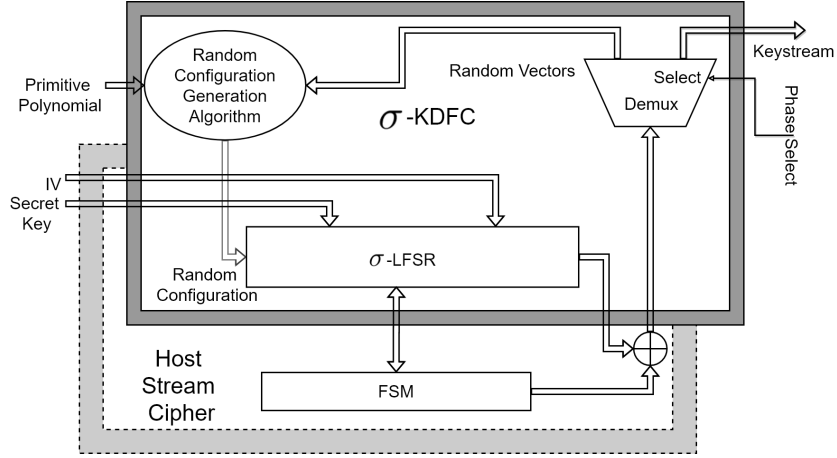

Fig. 2. The Schematic of σ -KDFC

In order to create a keystream generator from the proposed σ -LFSR configuration, it can be connected to a Finite state machine which introduces non-linearity. Figure 2 shows the schematic of the proposed scheme along with its interconnection with an FSM. The scheme has an initialization phase wherein the feedback configuration of the σ -LFSR is calculated by running Algorithm 1. In order to reduce the time taken for initialization, Algorithm 1 is run offline (at some server) till k iterations of step 3 and the resulting matrix Y is made public. The number k can be chosen depending on the computational capacity of the machine that hosts the σ -LFSR. The feedback configuration is calculated by running the remaining part of the algorithm in the initialization phase. In this phase there is no keystream generated at the output. The following subsection explains the initialization phase in detail.

3.1 The Initialization Phase

During the initialization phase the σ -LFSR has a publicly known feedback configuration. Further, the pre-calculated matrix $Y \in \mathbb{F}_2^{m \times (m+k)}$, and the primitive polynomials $p_{m+k+1}(x), p_{m+k+2}(x), \dots, p_{mb}(x)$ are also publicly known. The initial state of the σ -LFSR is derived from the secret key and the IV. (as is normally done in word based stream ciphers like SNOW). The σ -LFSR is run along with the FSM for $mb - m - k$ clock cycles. This generates $mb - m - k$ vectors in \mathbb{F}_2^m . This corresponds to the $mb - m - k$ remaining iterations of Step 3 in Algorithm 1.

The remaining part of Algorithm 1 is now run. In each iteration of Step 3, the boolean numbers appended to the rows of the matrix Y in Step 3(b) are the entries of the the corresponding vector. More precisely, in the i -th iteration of Step 3 that is run on the keystream generator, for $t \neq i + k \bmod m$, the t -th row of Y is appended with the t -th entry of the i -th vector that was generated.

The feedback gains of the σ -LFSR are now set according to the configuration matrix that is generated by Algorithm 1.

Once the feedback gains are set the σ -LFSR is run along with the FSM. The first b vectors are discarded and the keystream starts from the $b + 1$ -th vector. The reason for doing this is that the initial state of the σ -LFSR with the new configuration is generated by the publicly known feedback configuration which is used in the initialization process.

Time Complexity of the Initialization Phase Step 3(a) in Algorithm 1 involves solving a system of linear equations in less than mb variables. This can be done with a time complexity of $\mathcal{O}((mb)^3)$ using Gaussian elimination. The time complexity of Step 3(b) is linear in m while that of Step 3(c) is constant. Further, Step 3 has $mb - m - k$ iterations. Therefore, if k is chosen such that $mb - m - k$ is $\mathcal{O}(1)$, then the overall time complexity of Step 3 is $\mathcal{O}((mb)^3)$. In Step 5, the matrix C can be calculated by solving the linear system of equations $CQ = QP_{mb}$ for C . This can be done in $\mathcal{O}((mb)^4)$ using Gaussian elimination. Step 4 has a time complexity of $\mathcal{O}((mb)^3)$. Thus, the time complexity of the initialization phase is $\mathcal{O}((mb)^4)$.

4 Algebraic Analysis of σ -KDFC

The entries of the feedback matrices, B_0, B_1, \dots, B_{b-1} , calculated by the procedure given in the previous section are functions of the matrix Y generated in Step 3 of Algorithm 1. The entries of Y are in turn non-linear functions of the initial state of the σ -LFSR.

Note that the last row of Y is always e_1^n . Let the first $m - 1$ rows of Y be v_1, v_2, \dots, v_{m-1} . Let \mathcal{U} be the set of variables that denote the entries in these rows. Therefore,

$$B_k(i, j) = f_{k(i,j)}(\mathcal{U}) \text{ for } 0 \leq k \leq b - 1 \text{ and } 1 \leq i, j \leq m \quad (5)$$

where $f_{k(i,j)}$ s are polynomial functions.

The algebraic degree of the configuration matrix, denoted by Θ , is defined as follows

$$\Theta(C_S) = \max_{k,i,j} (|f_{k(i,j)}(\mathbf{u})|) \quad (6)$$

Θ can be considered as a measure of the algebraic resistance of σ -KDFC. We now proceed to find a lower bound for Θ .

The matrix Q generated in Step 4 of Algorithm 1 is given as follows

$$Q = \begin{bmatrix} v_1 \\ v_2 \\ \vdots \\ v_{m-1} \\ e_1^n \\ v_1 P_{mb} \\ \vdots \\ v_{m-1} P_{mb} \\ e_1^n P_{mb} \\ \vdots \\ v_1 P_{mb}^{b-1} \\ \vdots \\ v_{m-1} P_{mb}^{b-1} \\ e_1 P_{mb}^{b-1} \end{bmatrix} \quad (7)$$

where P_{mb} is the companion matrix of the publicly known primitive characteristic polynomial of the σ -LFSR. The configuration matrix C is generated by the formula $C = Q \times P_{mb} \times Q^{-1}$. Since Q is an invertible boolean matrix, the determinant of Q is always 1. Therefore, $Q^{-1} = Q^{(a)}$ where $Q^{(a)}$ is the adjugate of Q . Moreover, since the elements of Q belong to \mathbb{F}_2 , the co-factors are equal to the minors of Q . The rows of Q can be permuted to get the following matrix Q_P

$$Q^P = \begin{bmatrix} e_1^n \\ e_1^n P_{mb} \\ \vdots \\ e_1 P_{mb}^{b-1} \\ v_1 \\ v_1 P_{mb} \\ \vdots \\ v_1 P_{mb}^{b-1} \\ \vdots \\ v_{m-1} \\ v_{m-1} P_{mb} \\ \vdots \\ v_{m-1} P_{mb}^{b-1} \end{bmatrix} = \begin{pmatrix} 0 & 0 & \cdots & 0 & 0 & \cdots & 0 & 1 \\ 0 & 0 & \cdots & 0 & 0 & \cdots & 1 & * \\ \vdots & \vdots & \cdots & \vdots & \vdots & & & \\ 0 & 0 & \cdots & 0 & 1 & * & * & \\ v_{1,1} & v_{1,2} & \cdots & v_{1,n-b} & v_{1,n-b+1} & \cdots & v_{1,n-1} & v_{1,n} \\ v_{1,2} & v_{1,3} & \cdots & v_{1,n-b+1} & v_{1,n-b+2} & \cdots & v_{1,n} & * \\ \vdots & \vdots & \cdots & \vdots & \vdots & & & \\ v_{1,b} & v_{1,b+1} & \cdots & v_{1,n} & v_{1,n+1} & \cdots & * & * \\ v_{2,1} & v_{2,2} & \cdots & v_{2,n-b} & v_{2,n-b+1} & \cdots & v_{2,n-1} & v_{2,n} \\ v_{2,2} & v_{2,3} & \cdots & v_{2,n-b+1} & v_{2,n-b+2} & \cdots & v_{2,n} & * \\ \vdots & \vdots & \cdots & \vdots & \vdots & & & \\ v_{2,b} & v_{2,b+1} & \cdots & v_{2,n} & v_{2,n+1} & \cdots & * & * \\ \vdots & \vdots & \cdots & \vdots & \vdots & & & \\ v_{m-1,1} & v_{m-1,2} & \cdots & v_{m-1,n-b} & v_{m-1,n-b+1} & \cdots & v_{m-1,n-1} & v_{m-1,n} \\ v_{m-1,2} & v_{m-1,3} & \cdots & v_{m-1,n-b+1} & v_{m-1,n-b+2} & \cdots & v_{m-1,n} & * \\ \vdots & \vdots & \cdots & \vdots & \vdots & & & \\ v_{m-1,b} & v_{m-1,b+1} & \cdots & v_{m-1,n} & v_{m-1,n+1} & \cdots & * & * \end{pmatrix} \quad (8)$$

where *s are linear combinations of the entries of the previous row. Note that Q^{-1} can be got by permuting the rows of Q_P^{-1}

The matrix Q_P can be decomposed as follows into four sub-matrices Q_1, Q_2, Q_3 and Q_4 :

$$\begin{array}{c}
Q_1 = \begin{pmatrix} 0 & 0 & \cdots & 0 \\ 0 & 0 & \cdots & 0 \\ \vdots & \vdots & \cdots & \vdots \\ 0 & 0 & \cdots & 0 \end{pmatrix}_{b \times n-b} \\
\hline
Q_P = \begin{pmatrix} v_{1,1} & v_{1,2} & \cdots & v_{1,mb-b} \\ v_{1,2} & v_{1,3} & \cdots & v_{1,mb-b+1} \\ \vdots & \vdots & \cdots & \vdots \\ v_{1,b} & v_{1,b+1} & \cdots & v_{1,mb} \\ v_{2,1} & v_{2,2} & \cdots & v_{2,mb-b} \\ v_{2,2} & v_{2,3} & \cdots & v_{2,mb-b+1} \\ \vdots & \vdots & \cdots & \vdots \\ v_{2,b} & v_{2,b+1} & \cdots & v_{2,mb} \\ \vdots & \vdots & \cdots & \vdots \\ v_{m-1,1} & v_{m-1,2} & \cdots & v_{m-1,mb-b} \\ v_{m-1,2} & v_{m-1,3} & \cdots & v_{m-1,mb-b+1} \\ \vdots & \vdots & \cdots & \vdots \\ v_{m-1,b} & v_{m-1,b+1} & \cdots & v_{m-1,mb} \end{pmatrix}_{mb-b \times mb-b} \\
Q_3 = \\
Q_4 = \begin{pmatrix} v_{1,mb-b+1} & \cdots & v_{1,mb-1} & v_{1,mb} \\ v_{1,mb-b+2} & \cdots & v_{1,mb} & * \\ \vdots & \vdots & \cdots & \vdots \\ v_{1,mb+1} & \cdots & * & * \\ v_{2,mb-b+1} & \cdots & v_{2,mb-1} & v_{2,mb} \\ v_{2,mb-b+2} & \cdots & v_{2,mb} & * \\ \vdots & \vdots & \cdots & \vdots \\ v_{2,mb+1} & \cdots & * & * \\ \vdots & \vdots & \cdots & \vdots \\ v_{m-1,mb-b+1} & \cdots & v_{m-1,mb-1} & v_{m-1,mb} \\ v_{m-1,mb-b+2} & \cdots & v_{m-1,mb} & * \\ \vdots & \vdots & \cdots & \vdots \\ v_{1,mb+1} & \cdots & * & * \end{pmatrix}_{mb \times mb} \\
\end{array} \tag{9}$$

Since Q_P is invertible, $\det(Q_P) = \det(Q_3) = 1$.

Let Γ_k be the set of polynomial functions of \mathcal{U} variables with degree k . We now proceed to analyse some of the minors of Q_P .

Lemma 1. For $1 \leq j \leq (mb - b)$, $\mu(Q_P[b, j]) \in \Gamma_{mb-b}$

Proof. For two matrices A and B with the same number of rows, let $[AB]_{p,q}$ be the matrix which is got by removing the p^{th} column from A and appending the q^{th} column of B to A . For $i = b$ and $1 \leq j \leq (mb - b)$, $\mu(Q_P[i, j])$ is given by:

$$\mu(Q_P[i, j]) = \det([Q_3 Q_4]_{j,1}) \tag{10}$$

Recall that, for a binary matrix $M \in \mathbb{F}_2^{mb \times mb}$, its determinant is given by the following formula,

$$\det(M) = \sum_{f \in S_{mb}} \prod_{1 \leq i \leq n} M(i, f(i)) \tag{11}$$

where S_{mb} is the set of permutations on $(1, 2, \dots, mb)$. Observe that the diagonal elements of $([Q_3 Q_4]_{j,1})$ are distinct $v_{i,k}$ s. Their product corresponds to the identity permutation in the determinant expansion formula for $([Q_3 Q_4]_{j,1})$. The resultant monomial has degree $mb - b$. Further, this monomial will not occur as a result of any other permutation. Hence $\det([Q_3 Q_4]_{j,1})$ is always a polynomial of degree $mb - b$.

Lemma 2. *If $1 \leq i \leq b$ then*

$$\mu(Q_P[i, j]) = \begin{cases} \det(Q_3) & i + j = mb + 1 \\ 0 & i + j \geq mb + 1 \end{cases} \quad (12)$$

Proof. Observe that, for $1 \leq i \leq b$ and $i + j = mb + 1$, the $Q_P[i, j]$ s are the anti-diagonal elements of Q_2 . Clearly, the minors of these elements are all equal to the determinant of Q_3 . As we have already seen, the invertibility of Q_P implies that this determinant is always 1. Therefore, $\mu(Q_P[i, j]) = 1$ when $i + j = mb + 1$.

Note that, for $1 \leq i \leq b$ and $i + j > mb + 1$, the $Q_P[i, j]$ s are the elements of Q_2 that are below the anti-diagonal. Observe that, if the row and column corresponding to such an element are removed from Q_P , then the first $b - 1$ rows of the resulting matrix are always rank deficient. Therefore, the determinant of this matrix is always 0. Therefore, $\mu(Q_P[i, j]) = 0$.

Lemma 3. *If $b + 1 \leq i \leq mb$ and $1 \leq j \leq n - b$, then $\mu(Q_P[i, j]) \in \Gamma_{mb-b-1}$.*

Proof. Observe that the elements of Q_P considered in this lemma are elements of the sub-matrix Q_3 . Therefore, $\mu(Q_P[i, j])$, for the range of i and j considered, is nothing but the determinant of the sub-matrix of Q_3 got by deleting the i^{th} row and j^{th} column of Q_3 . The diagonal elements of such a sub-matrix are distinct $v_{i,j}$ s. Their product will result in a monomial of degree $mb - b - 1$. This corresponds to the identity permutation in the determinant expansion formula given by Equation 10. Observe that no other permutation generates this monomial. Hence, the minor will always have a monomial of degree $mb - b - 1$. Therefore, $\mu(Q_P[i, j]) \in \Gamma_{mb-b-1}$.

Lemma 4. *If $b + 1 \leq i \leq n$ and $mb - b + 1 \leq j \leq mb$, then $\mu(Q_P[i, j]) = 0$.*

Proof. The elements of Q_P considered in this lemma are elements of the sub-matrix Q_4 . Whenever the row and column corresponding to such an element is removed from Q_P , the rows of the submatrix Q_2 become linearly dependent. Therefore, the first b rows of the resultant matrix are always rank deficient. Consequently, $\mu(Q_P[i, j]) = 0$.

For a given matrix A with polynomial entries, let $\Theta(A)$ be the maximum degree among all the entries of A . As there are $mb - b$ rows in Q_P with variable entries, $\Theta(Q_P^{-1}) \leq mb - b$. Therefore, we get the following as a consequence of Lemma 1.

$$\Theta(Q^{-1}) = \Theta(Q_P^{-1}) = mb - b \quad (13)$$

Recall that the configuration matrix \mathcal{C} is given by $QP_{mb}Q^{-1}$. We now use the above developed machinery to calculate $\Theta(\mathcal{C})$.

Theorem 1. $\Theta(\mathcal{C}) \geq mb - b$.

Proof. Observe that the gain matrices B_0, B_1, \dots, B_{b-1} appear in the last m rows of C_S . These rows are generated by multiplying the last m rows QP_{mb} with Q^{-1} . The last m rows of QP_{mb} are as follows

$$\begin{pmatrix} 0 & 0 \cdots & 1 * \cdots * * \\ v_{1,b+1} & v_{1,b+2} \cdots & v_{1,mb} * \cdots * * \\ v_{2,b+1} & v_{2,b+2} \cdots & v_{2,mb} * \cdots * * \\ \vdots & \vdots \cdots & \vdots \cdots \vdots \\ v_{m-1,b+1} & v_{m-1,b+2} \cdots & v_{m-1,mb} * \cdots * * \end{pmatrix} \in \mathbb{F}_2^{b \times mb} \quad (14)$$

The element $C[mb-m+1, mb-m+1]$ is got by multiplying the $(mb-m+1)$ -th row of QP_{mb} with the $(mb-m+1)$ -th column of Q^{-1} . Note that the $(mb-m+1)$ -th column of Q^{-1} is equal to the b -th column of Q_P^{-1} . As a consequence of Lemmas 1 and 2, this column has the following form.

$$Q^{-1}[:, mb-m+1] = (P_1, P_2, \dots, P_{mb-b}, 1, 0, \dots, 0)^T \quad (15)$$

where $P_1, P_2, \dots, P_{mb-b} \in \Gamma(mb-b)$. Therefore,

$$\begin{aligned} C[mb-b+1, mb-b+1] &= (\underbrace{0, 0, \dots, 1}_{(mb-b) \text{ entries}}, *, \dots, *, *) \times (P_1, P_2, \dots, P_{mb-b}, 1, 0, \dots, 0)^T \\ &= P_{mb-b} \end{aligned}$$

Hence, it is proved that $\Theta(C) \geq mb-b$.

Example 1. Consider a primitive σ -LFSR with 4, 2-input 2-output delay blocks i.e. $m = 2$ and $b = 4$. Therefore $n = mb = 8$. The primitive polynomial for the companion matrix P_z is $f(x) = x^8 + x^4 + x^3 + x^2 + 1$. The corresponding matrices Q and Q_P have the following structure:

$$Q = \begin{pmatrix} 0 & 0 & 0 & 0 & 0 & 0 & 0 & 1 \\ x_1 & x_2 & x_3 & x_4 & x_5 & x_6 & x_7 & x_8 \\ 0 & 0 & 0 & 0 & 0 & 0 & 1 & 0 \\ x_2 & x_3 & x_4 & x_5 & x_6 & x_7 & x_8 & x_1 + x_3 + x_4 + x_5 \\ 0 & 0 & 0 & 0 & 0 & 1 & 0 & 0 \\ x_3 & x_4 & x_5 & x_6 & x_7 & x_8 & x_1 + x_3 + x_4 + x_5 & x_2 + x_4 + x_5 + x_6 \\ 0 & 0 & 0 & 0 & 1 & 0 & 0 & 0 \\ x_4 & x_5 & x_6 & x_7 & x_8 & x_1 + x_3 + x_4 + x_5 & x_2 + x_4 + x_5 + x_6 & x_3 + x_5 + x_6 + x_7 \end{pmatrix} \quad (16)$$

$$Q^P = \frac{\begin{array}{c} Q_1 = \begin{pmatrix} 0 & 0 & 0 & 0 \\ 0 & 0 & 0 & 0 \\ 0 & 0 & 0 & 0 \\ 0 & 0 & 0 & 0 \end{pmatrix} \\ Q_3 = \begin{pmatrix} x_1 & x_2 & x_3 & x_4 \\ x_2 & x_3 & x_4 & x_5 \\ x_3 & x_4 & x_5 & x_6 \\ x_4 & x_5 & x_6 & x_7 \end{pmatrix} \end{array} \left| \begin{array}{c} Q_2 = \begin{pmatrix} 0 & 0 & 0 & 1 \\ 0 & 0 & 1 & 0 \\ 0 & 1 & 0 & 0 \\ 1 & 0 & 0 & 0 \end{pmatrix} \\ Q_4 = \begin{pmatrix} x_5 & x_6 & x_7 & x_8 \\ x_6 & x_7 & x_8 & x_1 + x_3 + x_4 + x_5 \\ x_7 & x_8 & x_1 + x_3 + x_4 + x_5 & x_2 + x_4 + x_5 + x_6 \\ x_8 & x_1 + x_3 + x_4 + x_5 & x_2 + x_4 + x_5 + x_6 & x_3 + x_5 + x_6 + x_7 \end{pmatrix} \end{array} \right. \quad (17)$$

The 4-th row of Q^P or the 7-th column of Q^{-1} is given by

$$Q^{-1}[:, 7] = (P_1, P_2, P_3, P_4, 1, 0, 0, 0)$$

where

$$P_1 : x_2x_4x_6x_8 + x_2x_4x_7 + x_2x_5x_8 + x_2x_6 + x_3x_6x_8 + x_3x_7 + x_4x_5x_6 + x_4x_6 + x_4x_8 + x_5.$$

$$P_2 : x_1x_4x_6x_8 + x_1x_4x_7 + x_1x_5x_8 + x_1x_6 + x_2x_3x_6x_8 + x_2x_3x_7 + x_2x_4x_5x_8 + x_2x_4x_6x_7 + x_2x_5x_6 + x_2x_5x_7 + x_3x_4x_8 + x_3x_5x_6 + x_3x_5x_8 + x_3x_6x_7 + x_4x_5 + x_4x_7$$

$$P_3 : x_1x_3x_6x_8 + x_1x_3x_7 + x_1x_4x_5x_8 + x_1x_4x_6x_7 + x_1x_5x_6 + x_1x_5x_7 + x_2x_3x_5x_8 + x_2x_3x_6x_7 + x_2x_4x_5x_7 + x_2x_4x_6 + x_2x_4x_8 + x_2x_5x_6 + x_2x_6x_8 + x_2x_7 + x_3x_4x_7 + x_3x_4x_8 + x_3x_5x_7 + x_3x_5 + x_4x_5 + x_4x_6$$

$$P_4 : x_1x_3x_5x_8 + x_1x_3x_6x_7 + x_1x_4x_5x_7 + x_1x_4x_6 + x_1x_4x_8 + x_1x_5x_6 + x_2x_3x_5x_7 + x_2x_3x_6 + x_2x_4x_7 + x_2x_5x_8 + x_2x_5 + x_2x_6x_7 + x_3x_4x_6 + x_3x_4x_7 + x_3x_8 + x_4x_5$$

Here, $C_S[7, 7]$, is equal to P_4 which is a polynomial of degree 4.

5 Case Study: Integration with SNOW 2.0

In this subsection, we first introduce SNOW 2.0, and then use it as a case study to show how σ -KDFC can be applied to an LFSR-based cipher stream. We refer to the resulting cipher as KDFC-SNOW.

5.1 SNOW 2.0:

The SNOW series of word based stream ciphers was first introduced in [EJ00]. This version of SNOW is known as SNOW 1.0. This was shown to be vulnerable to a linear distinguishing attack as well as a guess and determine attack [HJB09].

SNOW 2.0 (Adopted by ISO/IEC standard IS 18033-4) was introduced later in [EJ02] as a modified version of SNOW 1.0. This version was shown to be vulnerable to algebraic and other attacks [BG05, HJB09, AE09, DMC09, NP14, NW06]. We consider SNOW 2.0 as a test case and demonstrate how replacing the LFSR in this scheme with a σ -LFSR increases its resistance to various attacks.

The block diagram of SNOW 2.0 is shown in figure 3.

5.4 Governing Equations of KDFC-SNOW

Let $D_i^t \in \mathbb{F}_{2^{32}}$ denote the value stored in the i^{th} delay block at the t -th time instant after the key stream generation has started. The outputs of the delay blocks of the σ -LFSR are related as per the following equation:

$$D_{15}^{t+1} = B_0 D_0^t + B_1 D_1^t + \dots + B_{15} D_{15}^t \quad (18)$$

Therefore,

$$D_k^{t+1} = \begin{cases} D_{k+t+1}^0 & 0 \leq k+t+1 \leq 15 \\ B_0 D_0^{t+k} + B_1 D_1^{t+k} + \dots + B_{15} D_{15}^{t+k} & k+t+1 > 15 \end{cases} \quad (19)$$

The value of the keystream at the t -th time instant is given by the following equation Let F_t be the output of the FSM at time t ,

$$F_t = (D_{15}^t \boxplus R_1^t) + R_2^t \quad (20)$$

The registers are updated as follows:

$$R_1^{t+1} = D_5^t \boxplus R_2^t \quad (21)$$

$$R_2^{t+1} = S(R_1^t) \quad (22)$$

$$z^t = R_1^t \boxplus D_{15}^t + R_2^t + D_0^t = (R_2^{t-1} \boxplus D_4^t) \boxplus D_{15}^t + R_2^t + D_0^t \quad (23)$$

where R_1^t and R_2^t represent the values of registers R_1 and R_2 at time instant t . The operation " \boxplus " is defined as follows:

$$x \boxplus y = (x + y) \pmod{2^{32}} \quad (24)$$

The challenge for an adversary in this scheme is to find the gain matrices $\{B_0, B_1, \dots, B_{15}\}$ in addition to the initial state $\{D_0^0, \dots, D_{15}^0\}$.

Note that Equations 20 to 23 are got from the FSM. Since the FSM part of the keystream generator is identical for SNOW 2.0 and KDFC-SNOW these equations are identical for both schemes.

5.5 Security enhancement due to KDFC-SNOW

Algebraic Attack: We first briefly the Algebraic attack on SNOW 2 described in [BG05] and demonstrate why this attack becomes difficult with KDFC-SNOW. This attack first attempts to break a modified version of the scheme where the \boxplus operator is approximated by \oplus . The state of LFSR and the value of the registers at the end of the 32 initialization cycles are considered unknown variables. This accounts for a total of $512 + 32 = 544$ unknown variables. The algebraic degree of each of the S-box(S) equations (156 linearly independent quadratic equations in each clock cycle) is 2. Rearranging the terms in Equation 23, we get the following

$$R_2^t = (R_2^{t-1} \boxplus D_4^t) \boxplus D_{15}^t + D_0^t + z^t. \quad (25)$$

Note that $R_1^0 = R_2^0 + z^0 + D_0^0 + D_{15}^0$. Therefore, by approximating \boxplus as \oplus , Equation 25 expands to the following:

$$R_2^t = R_2^0 + \sum_{i=0}^t z^i + \sum_{i=0}^t (D_4^i + D_{15}^i + D_0^i) \quad (26)$$

Further, Equation 22 can be expanded as follows:

$$R_2^{t+1} = S(R_1^t) = S(R_2^t + z^t + D_{15}^t + D_0^t) \quad (27)$$

In Equation 27, the outputs of the delay blocks can be related to the initial state of the LFSR using the following equation.

$$D_k^{t+1} = \begin{cases} D_{k+t+1}^0 & 0 \leq k+t+1 \leq 15 \\ \alpha^{-1} D_{11}^{k+t} + D_2^{k+t} + \alpha D_0^{k+t} & k+t+1 > 15 \end{cases} \quad (28)$$

Because of the nature of the S -Box, Equation 27 gives rise to 156 quadratic equations per time instant ([BG05]). When these equations are linearized, the number of variables increases to $\sum_{i=0}^2 \binom{544}{i} \approx 2^{17}$. Therefore with $2^{17}/156 \approx 951$ samples, we get a system of equations, which can be solved in $\mathcal{O}(2^{51})$ time, to obtain the initial state of the LFSR and the registers. This attack is then modified to consider the \boxplus operator. This attack has a time complexity of approximately $\mathcal{O}(2^{294})$.

When the LFSR in SNOW 2.0 is replaced by a σ -LFSR, the feedback equation is no longer known. If the entries of the feedback gain matrices are considered as unknowns, then there are a total of $16 * m^2 + mb + m = 16928$ unknown variables (This includes the $16 * m^2$ entries of the feedback matrices and $mb + m$ entries corresponding to the state of the LFSR and the register R_2 at the beginning of the key stream). The output of the delay blocks at any given instant are functions of these variables. Here, Equation 28 is replaced by Equation 19. Now, if the outputs of the delay blocks in Equation 27 are linked to the initial state of the LFSR (i.e. the state when the key stream begins) using Equation 19 instead of Equation 28, then the resulting equations contain the feedback matrices and their products. For example, in the expressions for R_2^2 and R_2^3 , D_{15}^1 and D_{15}^2 are given as follows

$$\begin{aligned} D_{15}^1 &= B_0 D_0^0 + B_1 D_1^0 + \dots + B_{15} D_{15}^0 \\ D_{15}^2 &= B_0 D_0^1 + B_1 D_1^1 + \dots + B_{15} D_{15}^1 \\ &= B_0 D_1^0 + B_1 D_2^0 + \dots + B_{15} (B_0 D_0^0 + B_1 D_1^0 + \dots + B_{15} D_{15}^0) \\ &= B_{15} B_0 D_0^0 + (B_{15} B_1 + B_0) D_1^0 + \dots + (B_{15} B_{15} + B_{14}) D_{15}^0 \end{aligned}$$

Observe that, while D_{15}^1 is a polynomial of degree two in the unknown variables, D_{15}^2 is a polynomial of degree 3. Similarly, with each successive iteration the degree of the expression for D_{15}^t keeps increasing, till all the $m^2 b$ entries of the

feedback matrices are multiplied with each other. A similar thing happens with the expressions for D_0^i . This results in a set of polynomial equations having maximum degree equal to $m^2b + 1 = 16385$. Therefore, although the equations generated by Equation 27 are quadratic in terms of the initial state of the σ -LFSR, they are no longer quadratic in the set of all unknowns. We instead have a system of equations in 16982 variables with a maximum degree of degree of over 16000. Linearizing such a system will give us a system of linear equations in $N = \sum_{i=0}^M \binom{16416}{i}$ unknowns where M is higher than 16000. Such an attack is therefore not feasible.

One could instead consider the rows of the matrix Y generated by Algorithm 1 as unknowns. Assuming that the first row is e_1^n , the total number of unknowns will now be $31 * 512 = 15872$. As we have already seen, the entries of the feedback matrices (B_i s) are polynomials in these variables. From Theorem 1, the maximum degree of these polynomials is atleast $mb - b$. Therefore, the maximum degree of the equations generated by Equation 27 will be atleast $mb - b + 1 = 497$. Therefore, linearizing this system of equations gives rise to a system of linear equations in $N = \sum_{i=0}^{497} \binom{16416}{i} \approx \mathcal{O}(2^{3207})$ unknowns. Therefore, an algebraic attack on this scheme that uses linearization seems unfeasible.

Distinguishing Attack: In the distinguishing attack, the attacker aims to distinguish the generated keystream from a random sequence. Distinguishing attacks on SNOW 2.0 have been launched using the linear masking method [WBDC03,NW06,LLP08]. This method essentially adapts the linear cryptanalysis method given in [Mat93] to stream ciphers. In this method, the algorithm of the key stream generator is assumed to consist of two parts, a linear one and a non-linear one. In the case of SNOW 2.0, the linear part is the LFSR and the non-linear part is the FSM. The linear part satisfies a linear recurring relation of the form $f(x_n, x_{n+1}, x_{n+2}, \dots, x_{n+k}) = 0$ for all n . We then try to find a linear relation, called the masking relation, that the non-linear part approximately satisfies. This relation is of the following form:

$$\sum_{i=0}^{\ell_1} \Gamma_i x_{n+i} = \sum_{i=0}^{\ell_2} A_i z_{n+i} \quad (29)$$

where z_0, z_1, \dots is the output sequence of the key stream generator. The Γ_i s and A_i s are linear masks that map the corresponding x_{n+i} s and z_{n+i} s to \mathbb{F}_2 respectively. The error in the masking relation can be seen as a random variable. If p is the probability that the non linear part satisfies Equation 29, then $p - \frac{1}{2}$ is called the bias of the masking relation. The Masking relation along with the linear recurring relation is used to generate a relation in terms of the elements of the output sequence. The error in this relation can also be seen as a random variable. If the probability of the sequence satisfying this relation is p_f , then $p_f - \frac{1}{2}$ is the bias of this relation. This bias can be related to the bias of the masking relation using the piling up lemma in [Mat93]. The main task in this type of attack is to find masks Γ_i s and A_i 's which maximise the bias of the

masking relation. The following linear masking equation is used in [WBDC03] and [NW06] for the FSM of SNOW 2.

$$\Gamma_0 x_n + \Gamma_1 x_{n+1} + \Gamma_5 x_{n+5} + \Gamma_{15} x_{n+15} + \Gamma_{16} x_{n+16} = \Lambda_0 z_n + \Lambda_1 z_{n+1} \quad (30)$$

In [WBDC03] it is assumed that all the Γ_i s and Λ_i s are equal to each other. In [NW06] it is assumed that Γ_0, Γ_{15} and Λ_0 are equal to each other. $\Gamma_1, \Gamma_5, \Gamma_{16}$ and Λ_1 are also assumed to be equal. Since $f(x_n, x_{n+1}, \dots, x_{n+k})$ is a linear relation, the following relation can be written purely in terms of the z_i s

$$\begin{aligned} & \Gamma_0 f(x_n, x_{n+1}, \dots, x_{n+k}) + \Gamma_1 f(x_{n+1}, x_{n+2}, \dots, x_{n+k+1}) \\ & + \Gamma_5 f(x_{n+5}, x_{n+6}, \dots, x_{n+k+5}) + \Gamma_{15} f(x_{n+15}, x_{n+16}, \dots, x_{n+k+15}) \\ & + \Gamma_{16} f(x_{n+16}, x_{n+17}, \dots, x_{n+k+16}) = 0 \end{aligned}$$

The linear relation between the elements of the output sequence in both [WBDC03] and [NW06] is obtained using this method. Further, if there are ℓ non-zero coefficients in f , then the random variable corresponding to the error in this relation is a sum of ℓ random variables each corresponding to the error in the linear masking equation.

In the proposed σ -LFSR configuration, the feedback equation is not known. Therefore the only known linear recurring relation that the output of the σ -LFSR satisfies is the one defined by its characteristic polynomial. If the characteristic polynomial is assumed to be the same as that of the LFSR in SNOW 2, then the corresponding linear recurring relation has 250 non-zero coefficients. Further, since these coefficients are elements of \mathbb{F}_2 , the non-zero coefficients are all equal to 1. Therefore, as a consequence of the piling up lemma, if the bias of the masking equation is ϵ , then the bias of the relation between the elements of the key stream is given as follows

$$\epsilon_{final} = 2^{249} \times \epsilon^{250} \quad (31)$$

The number of elements of the key stream needed to distinguish it from a random sequence is $\frac{1}{\epsilon_{final}^2}$. Therefore, for an identical linear masking equation, the length of the key stream for the distinguishing attack is much higher for the proposed configuration as compared to SNOW 2. This is demonstrated in the following table.

Reference	ϵ	ϵ_{final} (SNOW 2.0)	ϵ_{final} (KDFC-SNOW)	#Keystream (SNOW 2.0)	#Keystream (KDFC-SNOW)
[WBDC03]	$2^{-27.61}$	$2^{-112.25}$	$2^{-6653.5}$	2^{225}	2^{13307}
[NW06]	$2^{-15.496}$	$2^{-86.9}$	2^{-3625}	2^{174}	2^{250}

Table 1. Comparison of required length of key stream for the distinguishing attack

Fast Correlation Attack: The Fast Correlation Attack is a commonly used technique for the cryptanalysis of LFSR based stream ciphers. This method was

first introduced for bitwise keystreams in ([MS89]). Here, the attacker views windows of the key stream as noisy linear encodings of the initial state of the LFSR. She then tries to recover the initial state by decoding this window. Further, linear combinations of elements in this window can be seen as encodings of subsets of the initial state. This results in smaller codes which are more efficient to decode [CJS00]. The linear recurring relation satisfied by the output of the LFSR is used to generate the parity check matrix for this code. A Fast correlation attack for word based stream ciphers was first described in [JJ01]. An improvement on this attack is given in [LLP08]. Both these schemes consider a linear recurring relation with coefficients in \mathbb{F}_2 . For SNOW 2.0, this relation has order 512. This is equivalent to considering each component sequence to be generated by a conventional bitwise LFSR having the same characteristic polynomial as the LFSR in SNOW 2.0. The time complexity of the attack given in [LLP08] is $2^{212.38}$. The scheme in [ZXM] considers the LFSR in SNOW 2.0 to be over \mathbb{F}_{2^8} . This results in a linear recurring relation of order 64. This modification results in a significant improvement in the time complexity of the attack. The time complexity of this attack is $2^{164.5}$ which is around 2^{49} times better than that of the attack given in [LLP08]. However, in order to derive the linear recurring relation over \mathbb{F}_{2^8} , the knowledge of the feedback function is critical.

In KDFC SNOW, the characteristic polynomial of the σ -LFSR is publicly known. The attacker can therefore generate a linear recurring relation over \mathbb{F}_2 that the output of the σ -LFSR satisfies. Therefore, the attack given in [LLP08] will also be effective against KDFC-SNOW. However, without the knowledge of the feedback function, the attacker will not be able to derive a linear recurring relation over \mathbb{F}_{2^8} . Hence, KDFC-SNOW is resistant against the attack given in [ZXM]. Thus, the best time complexity that a known fast correlation attack can achieve against KDFC SNOW is $2^{212.38}$

5.6 Guess and Determine Attack

In a Guess and Determine Attack, the attacker aims to estimate the values of a minimum number of variables using which the complete sequence can be constructed. For SNOW 2.0, this includes the values of the outputs of the delay blocks of the LFSR and the outputs of the registers of the FSM at some time instant. This is done by guessing some of the values and determining the rest of them using system equations. If the sequence generated using these estimates matches the output of the key-stream generator, then the guesses are deemed to be correct. Otherwise, a fresh set of guesses are considered. The set of variables whose values are guessed is known as the basis for the attack. For both SNOW 2.0 and KDFC-SNOW, these variables take their values from \mathbb{F}_2^{32} . Hence, if the size of the basis is k , then the probability of a correct guess is 2^{-32k} . Thus, on average, one needs $\mathcal{O}(2^{-32k})$ attempts to make a correct guess. Therefore, the problem here is to find a basis of the minimum possible size. A systematic Vitterbi-like algorithm for doing this is given in [AE09]. The complexity of this attack was found to be 2^{265} ([AE09]) for SNOW2.0. The complexity of this attack reduced to 2^{192} in ([NP14]) by incorporating a couple of auxiliary equations.

We now briefly describe the algorithm given in [AE09] in the context of SNOW 2.0

Consider the following equations which are satisfied by SNOW 2.0

$$D_t^{16} = \alpha^{-1}D_t^{11} + D_2^t + \alpha D_t \quad (32)$$

$$R1_t = D_t^4 + S(R1_{t-2}) \quad (33)$$

$$z_t = D_t + (D_t^{15} + R1_t) + S(R1_{t-1}) \quad (34)$$

These equations are used to generate the following tables The entries in the

0	2	11	16
1	3	12	17
⋮	⋮	⋮	⋮
18	20	29	34

4	35	37
5	36	38
⋮	⋮	⋮
22	53	55

0	15	36	37
1	16	37	38
⋮	⋮	⋮	⋮
18	33	54	55

Table 2. Index table for SNOW 2.0

above tables correspond to the variables that are to be estimated. The entries in the first table, i.e. 0 to 34, correspond to 35 consecutive outputs of the LFSR. The entries 35 to 55 correspond to 21 consecutive entries of Register $R1$. Each row of the above tables correspond to the values of the delay blocks and registers in Equations 32, 33 and 34 at a particular time instant.

We now consider a multi stage graph with 56 nodes in each stage corresponding to the 56 entries in the above tables. Each node is connected to all the nodes in the next stage giving rise to a trellis diagram. An entry is said to be eliminated by a path if, knowing the values of the entries corresponding to the nodes in the path, the value of that entry can be calculated.

We now recursively calculate an optimal path that eliminates all the entries. The desired basis corresponds to the nodes in this path. In the i -th iteration of this algorithm we calculate the optimal path of length i to each node in the i -th stage. In order to find the optimal path to the k -th node, we consider all the incoming edges of node k . By appending the node k to the optimal paths of length $i - 1$ ending at the source nodes of these edges, we get 55 paths of length i . We choose the edge corresponding to the path that eliminates the most number of variables. In case of a tie, we consider the path that results in the most number of rows with 2 unknowns and so on. This process is continued till we get a path that eliminates all the entries. This algorithm results in a basis of cardinality 8 for SNOW 2.0.

In KDFC-SNOW, the feedback equation of the σ -LFSR is not known. The smallest known linear recurring relation that the output of the σ -LFSR satisfies is the relation corresponding to its characteristic polynomial. This relation is

given as follows

$$\begin{aligned}
x_{n+512} = & x_{n+510} + x_{n+504} + x_{n+502} + x_{n+501} + x_{n+494} + x_{n+493} + x_{n+490} + \\
& x_{n+486} + x_{n+485} + x_{n+483} + x_{n+481} + x_{n+480} + x_{n+478} + x_{n+477} + x_{n+471} + \\
& x_{n+470} + x_{n+469} + x_{n+466} + x_{n+462} + x_{n+461} + x_{n+459} + x_{n+458} + x_{n+452} + \\
& x_{n+449} + x_{n+446} + x_{n+445} + x_{n+444} + x_{n+441} + x_{n+438} + x_{n+437} + x_{n+434} + \\
& x_{n+433} + x_{n+432} + x_{n+431} + x_{n+429} + x_{n+427} + x_{n+424} + x_{n+423} + x_{n+420} + \\
& x_{n+419} + x_{n+414} + x_{n+412} + x_{n+411} + x_{n+409} + x_{n+405} + x_{n+402} + x_{n+400} + \\
& x_{n+399} + x_{n+398} + x_{n+396} + x_{n+395} + x_{n+393} + x_{n+392} + x_{n+390} + x_{n+388} + \\
& x_{n+387} + x_{n+385} + x_{n+375} + x_{n+374} + x_{n+372} + x_{n+371} + x_{n+366} + x_{n+365} + \\
& x_{n+363} + x_{n+362} + x_{n+359} + x_{n+357} + x_{n+356} + x_{n+355} + x_{n+354} + x_{n+353} + \\
& x_{n+352} + x_{n+351} + x_{n+350} + x_{n+347} + x_{n+345} + x_{n+344} + x_{n+343} + x_{n+341} + \\
& x_{n+339} + x_{n+338} + x_{n+337} + x_{n+336} + x_{n+333} + x_{n+330} + x_{n+329} + x_{n+326} + \\
& x_{n+324} + x_{n+322} + x_{n+319} + x_{n+310} + x_{n+307} + x_{n+306} + x_{n+305} + x_{n+304} + \\
& x_{n+303} + x_{n+301} + x_{n+299} + x_{n+298} + x_{n+297} + x_{n+296} + x_{n+295} + x_{n+294} + \\
& x_{n+293} + x_{n+292} + x_{n+291} + x_{n+289} + x_{n+286} + x_{n+285} + x_{n+283} + x_{n+282} + \\
& x_{n+281} + x_{n+278} + x_{n+276} + x_{n+274} + x_{n+271} + x_{n+269} + x_{n+264} + x_{n+262} + \\
& x_{n+259} + x_{n+258} + x_{n+257} + x_{n+255} + x_{n+253} + x_{n+251} + x_{n+249} + x_{n+248} + \\
& x_{n+243} + x_{n+240} + x_{n+239} + x_{n+238} + x_{n+236} + x_{n+235} + x_{n+233} + x_{n+232} + \\
& x_{n+230} + x_{n+229} + x_{n+228} + x_{n+227} + x_{n+226} + x_{n+222} + x_{n+217} + x_{n+216} + \\
& x_{n+215} + x_{n+214} + x_{n+213} + x_{n+210} + x_{n+208} + x_{n+206} + x_{n+203} + x_{n+201} + \\
& x_{n+199} + x_{n+193} + x_{n+190} + x_{n+184} + x_{n+179} + x_{n+178} + x_{n+177} + x_{n+175} + \\
& x_{n+174} + x_{n+173} + x_{n+172} + x_{n+171} + x_{n+169} + x_{n+165} + x_{n+164} + x_{n+163} + \\
& x_{n+158} + x_{n+156} + x_{n+155} + x_{n+153} + x_{n+152} + x_{n+151} + x_{n+149} + x_{n+147} + \\
& x_{n+146} + x_{n+143} + x_{n+141} + x_{n+138} + x_{n+136} + x_{n+132} + x_{n+131} + x_{n+129} + \\
& x_{n+128} + x_{n+126} + x_{n+125} + x_{n+124} + x_{n+123} + x_{n+121} + x_{n+120} + x_{n+119} + \\
& x_{n+118} + x_{n+117} + x_{n+116} + x_{n+115} + x_{n+113} + x_{n+112} + x_{n+111} + x_{n+109} + \\
& x_{n+105} + x_{n+104} + x_{n+103} + x_{n+102} + x_{n+98} + x_{n+97} + x_{n+94} + x_{n+93} + x_{n+89} \\
& \quad + x_{n+88} + x_{n+87} + x_{n+81} + x_{n+78} + x_{n+76} + x_{n+75} + x_{n+73} \\
& \quad + x_{n+72} + x_{n+70} + x_{n+69} + x_{n+68} + x_{n+67} + x_{n+66} + x_{n+65} + x_{n+63} \\
& \quad + x_{n+59} + x_{n+58} + x_{n+57} + x_{n+56} + x_{n+55} + x_{n+53} + x_{n+51} + x_{n+50} \\
& \quad + x_{n+49} + x_{n+47} + x_{n+46} + x_{n+45} + x_{n+44} + x_{n+41} + x_{n+39} + x_{n+37} \\
& \quad + x_{n+36} + x_{n+33} + x_{n+30} + x_{n+26} + x_{n+25} + x_{n+21} + x_{n+20} + x_{n+19} \\
& \quad \quad \quad + x_{n+16} + x_{n+5} + x_0
\end{aligned}$$

As in SNOW 2.0, the following equations are also satisfied,

$$\begin{aligned}
R1_n &= x_{n+4} + S(R1_{n-1}) \\
z_n &= x_n + (x_{n+15} + R1_n) + S(R1_{n-1})
\end{aligned}$$

The following tables can be constructed using these three equations. We ran the

512	510	504	502	...	5	0
513	511	505	503	...	6	1
⋮	⋮	⋮	⋮	⋮	⋮	⋮
1025	1023	1007	1005	...	516	513

4	1026	1028
5	1027	1029
⋮	⋮	⋮
517	1539	1541

0	15	1027	1028
1	16	1028	1029
⋮	⋮	⋮	⋮
513	528	1540	1541

Table 3. Index table for $f1(x)$, equation 32 and equation 34

Viterbi-like algorithm with the above tables on a cluster with 40 INTEL(R) XEON(R) CPUs (E5-2630 2.2GHz). The program ran for 16 iterations and generated the path $\{1041, 17, 15, 13, 28, 16, 11, 14, 9, 1050, 18, 39, 12, 7, 5, 0, 3\}$. This path has length 17. This corresponds to a time complexity of $\mathcal{O}(2^{544})$.

5.7 Randomness Test

In this subsection, we evaluate the randomness of the keystream generated by KDFC-SNOW.

Test Methodology

We have used the NIST randomness test suite to evaluate the randomness of a keystream generated by KDFC-SNOW. There are 16 randomness tests in the suite. Each test returns a level of significance i.e. $P - Value$. If this value is above 0.01 for a given test, then the keystream is considered to be random for that test.

KDFC-SNOW has been implemented using SageMath 8.0. The NIST randomness tests have been conducted on the generated keystream using Python 3.6. The characteristic polynomial of the σ -LFSR has been taken as $f(x) = x^{512} + x^{510} + x^{504} + x^{502} + x^{501} + x^{494} + x^{493} + x^{490} + x^{486} + x^{485} + x^{483} + x^{481} + x^{480} + x^{478} + x^{477} + x^{471} + x^{470} + x^{469} + x^{466} + x^{462} + x^{461} + x^{459} + x^{458} + x^{452} + x^{449} + x^{446} + x^{445} + x^{444} + x^{441} + x^{438} + x^{437} + x^{434} + x^{433} + x^{432} + x^{431} + x^{429} + x^{427} + x^{424} + x^{423} + x^{420} + x^{419} + x^{414} + x^{412} + x^{411} + x^{409} + x^{405} + x^{402} + x^{400} + x^{399} + x^{398} + x^{396} + x^{395} + x^{393} + x^{392} + x^{390} + x^{388} + x^{387} + x^{385} + x^{375} + x^{374} + x^{372} + x^{371} + x^{366} + x^{365} + x^{363} + x^{362} + x^{359} + x^{357} + x^{356} + x^{355} + x^{354} + x^{353} + x^{352} + x^{351} + x^{350} + x^{347} + x^{345} + x^{344} + x^{343} + x^{341} + x^{339} + x^{338} + x^{337} + x^{336} + x^{333} + x^{330} + x^{329} + x^{326} + x^{324} + x^{322} + x^{319} + x^{310} + x^{307} + x^{306} + x^{305} + x^{304} + x^{303} + x^{301} + x^{299} + x^{298} + x^{297} + x^{296} + x^{295} + x^{294} + x^{293} + x^{292} + x^{291} + x^{289} + x^{286} + x^{285} + x^{283} + x^{282} + x^{281} + x^{278} + x^{276} + x^{274} + x^{271} + x^{269} + x^{264} + x^{262} + x^{259} + x^{258} + x^{257} + x^{255} + x^{253} + x^{251} + x^{249} + x^{248} + x^{243} + x^{240} + x^{239} + x^{238} + x^{236} + x^{235} + x^{233} + x^{232} + x^{230} + x^{229} + x^{228} + x^{227} + x^{226} + x^{222} + x^{217} + x^{216} + x^{215} + x^{214} + x^{213} + x^{210} + x^{208} + x^{206} + x^{203} + x^{201} + x^{199} + x^{193} + x^{190} + x^{184} + x^{179} + x^{178} + x^{177} + x^{175} + x^{174} + x^{173} + x^{172} + x^{171} + x^{169} + x^{165} + x^{164} + x^{163} + x^{158} + x^{156} + x^{155} + x^{153} + x^{152} + x^{151} + x^{149} + x^{147} + x^{146} + x^{143} + x^{141} + x^{138} + x^{136} + x^{132} + x^{131} + x^{129} + x^{128} + x^{126} + x^{125} + x^{124} + x^{123} + x^{121} + x^{120} + x^{119} + x^{118} +$

$$x^{117} + x^{116} + x^{115} + x^{113} + x^{112} + x^{111} + x^{109} + x^{105} + x^{104} + x^{103} + x^{102} + x^{98} + x^{97} + x^{94} + x^{93} + x^{89} + x^{88} + x^{87} + x^{81} + x^{78} + x^{76} + x^{75} + x^{73} + x^{72} + x^{70} + x^{69} + x^{68} + x^{67} + x^{66} + x^{65} + x^{63} + x^{59} + x^{58} + x^{57} + x^{56} + x^{55} + x^{53} + x^{51} + x^{50} + x^{49} + x^{47} + x^{46} + x^{45} + x^{44} + x^{41} + x^{39} + x^{37} + x^{36} + x^{33} + x^{30} + x^{26} + x^{25} + x^{21} + x^{20} + x^{19} + x^{16} + x^5 + 1.$$

(This polynomial is the characteristic polynomial of the LFSR in SNOW 2.0 when it is implemented as a σ -LFSR i.e. when multiplication by α and α^{-1} are represented by matrices).

The keystream has been generated using the following key (K) and initialization vector (IV).

$$K = [681, 884, 35, 345, 203, 50, 912, 358], \quad IV = [645, 473, 798, 506] \quad (35)$$

Test Results

The results obtained from 14 NIST tests are shown in table 4.

Number	Test	P-Value	Random
01.	Frequency Test (Monobit)	0.35966689490586123	✓
02.	Frequency Test within a Block	0.24374184001729746	✓
03.	Run Test	0.9038184342313019	✓
04.	Longest Run of Ones in a Block	0.5246846287441829	✓
05.	Binary Matrix Rank Test	0.1371167998339736	✓
06.	Discrete Fourier Transform (Spectral) Test	0.1371167998339736	✓
07.	Non-Overlapping Template Matching Test	0.3189818228443801	✓
08.	Overlapping Template Matching Test	0.211350493609367	✓
09.	Maurer's Universal Statistical test	0.4521082097311434	✓
10.	Linear Complexity Test	0.1647939201114819	✓
11.	Serial Test	0.7821664366290292	✓
12.	Approximate Entropy Test	0.880218270580662	✓
13.	Cummulative Sums (Forward) Test	0.34630799549695923	✓
14.	Cummulative Sums (Reverse) Test	0.6633686090204551	✓

Table 4. NIST Randomness Test

The results obtained for the *Random Excursions Test* are shown in table 5.

State	CHI SQUARED	P-Value	Random
-4	9.375081555789523	0.09500667227464867	✓
-3	.9066918454935624	0.969735280059932	✓
-2	3.196312192020347	0.6697497097941535	✓
-1	5.343347639484978	0.3754291967984828	✓
1	5.446351931330472	0.363864453873992	✓
2	6.937635775976262	0.22531988887331122	✓
3	13.843145064377687	0.016637085511558194	✓
4	3.790226890440857	0.5799959469559587	✓

Table 5. 15. Random Excursions Test

Table 6 shows the results for the 16th test i.e. the *Random Excursions Variant Test*

State	Count	P-Value	Random	State	Count	P-Value	Random
'-9.0'	270	0.11944065987006025	✓	'+1.0'	467	0.9738690952237389	✓
'-8.0'	307	0.1787039957218327	✓	'+2.0'	488	0.6773674079894312	✓
'-7.0'	359	0.3310083710716354	✓	'+3.0'	470	0.9532739974827851	✓
'-6.0'	389	0.44696915370831947	✓	'+4.0'	416	0.5358953455898371	✓
'-5.0'	418	0.6002107789999439	✓	'+5.0'	386	0.3823929438406025	✓
'-4.0'	426	0.6204409395957975	✓	'+6.0'	397	0.495576078534262	✓
'-3.0'	439	0.6924575808023399	✓	'+7.0'	430	0.7436251044167517	✓
'-2.0'	486	0.7052562223122887	✓	'+8.0'	454	0.9191606777606087	✓
'-1.0'	486	0.512389348919496	✓	'+9.0'	481	0.9051424340008056	✓

Table 6. Randomness Excursions Variant Test

These results are comparable to that of SNOW 2.0. Note that the feedback configuration of SNOW 2.0 is one of the possible feedback configurations in the σ -KDFC scheme.

5.8 Challenges in implementation

The main problem of KDFC lies in its software implementation. Since the feedback function is not fixed, look up tables cannot be used in the implementation of the σ -LFSR. Further, the choice of the feedback configurations is not restricted to the set of efficiently implementable σ -LFSR configurations given in ([ZHH07]). This makes the implementation of KDFC SNOW extremely challenging.

In our implementation, the state of the σ -LFSR is stored as a set of 32 integers. The i -th integer corresponds to the i -th output of the delay blocks. Calculating the feedback function of the σ -LFSR involves calculating the bitwise XOR of a subset of the columns of the feedback matrices (B_i s). In order to make

the implementation more efficient, for all $1 \leq i \leq 32$, the i -th columns of the feedback matrices are stored in adjacent memory locations. Thus, each integer in the state of the σ -LFSR corresponds to a set of columns of the feedback matrices which are stored in a continuous block of memory. The state vector is now sampled one integer at a time and the columns of the B_i s corresponding to the non zero bits in these integers are XORed with each other. We then do a bit-wise right shift on each of these integers and introduce the result of the XOR operation bitwise as the most significant bits. In this way, the σ -LFSR can be implemented using bitwise XORs and shifts. The FSM is implemented as in SNOW 2.0 [EJ02]. This implementation takes 25 cycles to generate a single word on an Intel Probook 4440s machine with a 2.8 Ghz i5 processor.

Each iteration of Algorithm 1 involves solving a system of linear equations. This process is time consuming and contributes to increasing the initialization time. The initialization process was implemented using a C code with open mp (with 3 threads). In this implementation linear equations were solved using a parallel implementation of the LU decomposition algorithm. The initialization process took a total time of 5 to 15 seconds on an Intel Probook 4440s machine with a 2.8 Ghz i5 processor.

6 Conclusions

In this paper, we have described a method of using σ -LFSRs with key dependent feedback configurations in stream ciphers that use word based LFSRs. In this method, an iterative configuration generation algorithm(CGA) uses key-dependant random numbers to generate a random feedback configuration for the σ -LFSR. We have theoretically analysed the algebraic degree of the resulting feedback configuration As a test case, we have demonstrated how this scheme can be used along with the Finite State Machine of SNOW 2.0. We have analysed the security of the resulting key-stream generator against various attacks and have demonstrated the improvement in security as compared to SNOW 2.0. Further, the keystreams generated by the proposed method are comparable to SNOW 2.0 from a randomness point of view.

Acknowledgement

The authors are grateful to Prof. Harish K. Pillai, Department of Electrical Engineering, Indian Institute of Technology Bombay for his valuable guidance and Associate Prof. Gaurav Trivedi, Department of Electronics and Electrical Engineering, Indian Institute of Technology Guwahati for helping us with computational resources.

7 Declarations

7.1 Funding

Not applicable.

7.2 Conflict of Interest

Authors declare no conflict of interest.

7.3 Code availability

Code will be available upon request to the authors.

7.4 Authors' contributions

Not applicable.

7.5 Availability of data and material

Not applicable.

7.6 Consent to participate

Not applicable.

7.7 Consent for publication

All authors consent to the publication of the manuscript in *Cryptography and Communications* upon acceptance.

References

- AE09. Hadi Ahmadi and Taraneh Eghlidis. Heuristic guess-and-determine attacks on stream ciphers. *IET Information Security*, 3(2):66–73, 2009.
- AG98. N.K. Ahmad, A. Nanda and K. Garg. Critical role of primitive polynomials in an lfsr based testing technique. *Electronics Letters*, 24(15):953–956, 1998.
- ANA16. Diyana Afdhila, Surya Michrandi Nasution, and Fairuz Azmi. Implementation of stream cipher salsa20 algorithm to secure voice on push to talk application. In *IEEE Asia Pacific Conference on Wireless and Mobile (AP-WiMob)*, Bandung, Indonesia, September 2016. IEEE.
- BBC⁺08. Côme Berbain, Olivier Billet, Anne Canteaut, Nicolas Courtois, Henri Gilbert, Louis Goubin, Aline Gouget, Louis Granboulan, Cédric Lauradoux, Marine Minier, et al. Sosemanuk, a fast software-oriented stream cipher. In *New stream cipher designs*, pages 98–118. Springer, 2008.
- BG05. Olivier Billet and Henri Gilbert. Resistance of snow 2.0 against algebraic attacks. In *Cryptographers' Track at the RSA Conference*, pages 19–28, San Francisco, Ca, USA, February 2005. Springer.
- CHM⁺04. Kevin Chen, Matt Henricksen, William Millan, Joanne Fuller, Leonie Simpson, Ed Dawson, Hoon Jae Lee, and Sang Jae Moon. Dragon: A fast word based stream cipher. In *International Conference on Information Security and Cryptology*, Seoul, Korea (Republic of), December 2004.

- CJS00. Vladimir V Chepyzhov, Thomas Johansson, and Ben Smeets. A simple algorithm for fast correlation attacks on stream ciphers. In *International Workshop on Fast Software Encryption*, pages 181–195. Springer, 2000.
- DMC09. Blandine Debraize and Irene Marquez Corbella. Fault analysis of the stream cipher snow 3g. In *Workshop on Fault Diagnosis and Tolerance in Cryptography (FDTC)*, pages 105–112, Lausanne, Switzerland, September 2009. IEEE.
- EJ00. Patrik Ekdahl and Thomas Johansson. Snow – a new stream cipher. In *1st NESSIE Workshop*, Heverlee, Belgium, November 2000.
- EJ02. Patrik Ekdahl and Thomas Johansson. A new version of the stream cipher snow. In *International Workshop on Selected Areas in Cryptography*, pages 47–61, St. John’s, Newfoundland, Canada, August 2002. Springer.
- EJMY19. Patrik Ekdahl, Thomas Johansson, Alexander Maximov, and Jing Yang. A new snow stream cipher called snow-v. *IACR Transactions on Symmetric Cryptology*, pages 1–42, 2019.
- HJB09. Martin Hell, Thomas Johansson, and Lennart Brynielsson. An overview of distinguishing attacks on stream ciphers. *Cryptography and Communications*, 1(1):71–94, 2009.
- JJ01. Fredrik Jönsson and Thomas Johansson. Correlation attacks on stream ciphers over $\text{GF}(2^n)$. In *IEEE International Symposium on Information Theory (ISIT), 2001*, pages 140–140, 2001.
- KP11. Srinivasan Krishnaswamy and Harish K Pillai. On the number of linear feedback shift registers with a special structure. *IEEE transactions on information theory*, 58(3):1783–1790, 2011.
- KP14. Srinivasan Krishnaswamy and Harish K Pillai. On the number of special feedback configurations in linear modular systems. *Systems & Control Letters*, 66:28–34, 2014.
- KTS17. Shinsaku Kiyomoto, Toshiaki Tanaka, and Kouichi Sakurai. K2: A stream cipher algorithm using dynamic feedback control. In *International Conference on Security and Cryptography (SECRYPT)*, Barcelona, Spain, July 2017.
- LLP08. Jung-Keun Lee, Dong Hoon Lee, and Sangwoo Park. Cryptanalysis of sosemanuk and snow 2.0 using linear masks. In *International Conference on the Theory and Application of Cryptology and Information Security*, pages 524–538. Springer, 2008.
- Mat93. Mitsuru Matsui. Linear cryptanalysis method for des cipher. In *Workshop on the Theory and Application of Cryptographic Techniques*, pages 386–397. Springer, 1993.
- MS89. Willi Meier and Othmar Staffelbach. Fast correlation attacks on certain stream ciphers. *Journal of cryptology*, 1(3):159–176, 1989.
- NP14. Mohammad Sadegh Nemati Nia and Ali Payandeh. The new heuristic guess and determine attack on snow 2.0 stream cipher. *IACR Cryptology ePrint Archive*, 2014:619, 2014.
- NW06. Kaisa Nyberg and Johan Wallén. Improved linear distinguishers for snow 2.0. In *International Workshop on Fast Software Encryption*, pages 144–162, Graz, Austria, March 2006. Springer.
- PBC19. Maxime Pistono, Reda Bellafqira, and Gouenou Coatrieux. Secure processing of stream cipher encrypted data issued from iot: Application to a connected knee prosthesis. In *41st Annual International Conference of the IEEE Engineering in Medicine and Biology Society (EMBC)*, Berlin, Germany, July 2019. IEEE.

ros.

- WBDC03. Dai Watanabe, Alex Biryukov, and Christophe De Canniere. A distinguishing attack of snow 2.0 with linear masking method. In *International Workshop on Selected Areas in Cryptography*, pages 222–233. Springer, 2003.
- Xt11. FENG Xiu-tao. Zuc algorithm: 3gpp lte international encryption standard. *Information Security and Communications Privacy*, 12, 2011.
- ZHH07. Guang Zeng, Wenbao Han, and Kaicheng He. High efficiency feedback shift register: sigma-lfsr. *IACR Cryptology ePrint Archive*, 2007:114, 2007.
- ZXM. Bin Zhang, Chao Xu, and Willi Meier. Fast correlation attacks over extension fields, large-unit linear approximation and cryptanalysis of snow 2.0.