

Keyless Covert Communication via Channel State Information

Hassan ZivariFard, *Student Member, IEEE*, Matthieu R. Bloch, *Senior Member, IEEE*, and Aria Nosratinia, *Fellow, IEEE*

Abstract

We consider the problem of covert communication over a state-dependent channel when the channel state is available either non-causally, causally, or strictly causally, either at the transmitter alone, or at both transmitter and receiver. Covert communication with respect to an adversary, called “warden,” is one in which, despite communication over the channel, the warden’s observation remains indistinguishable from an output induced by innocent channel-input symbols. Covert communication involves fooling an adversary in part by a proliferation of codebooks; for reliable decoding at the legitimate receiver the codebook uncertainty is typically removed via a shared secret key that is unavailable to the warden. In contrast to previous work, we do not assume the availability of a shared key at the transmitter and legitimate receiver. Instead, shared randomness is extracted from the channel state in a manner that keeps it secret from the warden, despite the influence of the channel state on the warden’s output. When channel state is available at the transmitter and receiver, we derive the covert capacity region. When channel state is only available at the transmitter, we derive inner and outer bounds on the covert capacity. We provide examples for which the covert capacity is positive with knowledge of channel state information but is zero without it.

I. INTRODUCTION

Covert communication refers to scenarios in which reliable communication over a channel must occur while simultaneously ensuring that a separate channel output at a node called the warden has a distribution identical to that induced by an innocent channel symbol [1]–[5]. It is known that in a point-to-point Discrete Memoryless Channel (DMC) without state, the number of bits that can be reliably and covertly communicated over n channel transmissions scales at most as $O(\sqrt{n})$.¹ This result has motivated the study of other models in which positive rates are achievable, e.g., when the transmitter and the receiver share on the order of $\sqrt{n} \log(n)$ key bits [1]. Of particular relevance to the present work, Lee *et al.* [6] considered the problem of covert communication over a state-dependent channel in which the channel state is known either causally or non-causally to the transmitter but unknown to the receiver and the warden. The authors derived the covert capacity when the transmitter and the receiver share a sufficiently long secret key, as well as a lower bound on the minimum secret key length needed

H. ZivariFard and A. Nosratinia are with Department of Electrical Engineering, The University of Texas at Dallas, Richardson, TX, USA. M. R. Bloch is with School of Electrical and Computer Engineering, Georgia Institute of Technology, Atlanta, GA, USA. E-mail: hassan@utdallas.edu, matthieu.bloch@ece.gatech.edu, aria@utdallas.edu.

The material in this paper was presented in part at IEEE Information Theory Workshop 2019, Visby, Gotland, Sweden.

The work of H. ZivariFard and A. Nosratinia is supported by National Science Foundation (NSF) grant 1956213. The work of M. R. Bloch is supported by National Science Foundation (NSF) grant 1955401.

¹Except for the special case when the output distribution (at the warden) induced by the innocent symbol is a convex combination of the output distributions generated by the other input symbols [3].

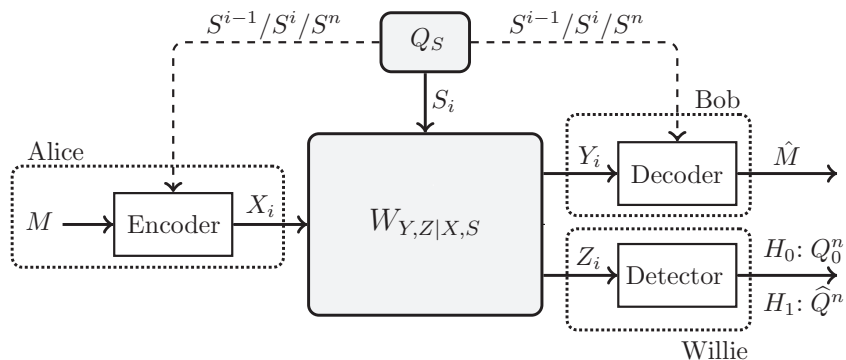

Fig. 1. Model of covert communication over state-dependent DMC when channel state is available at both the transmitter and the receiver

to achieve the covert capacity. Covert communication over a compound channel in which the object to be masked is the state of the compound channel was studied by Salehkalaibar *et al.* [7]. Given the presence of a channel state, one may wonder if covert communication with positive rate is possible *without* requiring an external secret key. In particular, several works demonstrated the benefits of exploiting common randomness and channel states to generate secret keys. For instance, the problem of stealth secret key generation from correlated sources was studied by Lin *et al.* [8], [9] and covert secret key generation was studied by Tahmasbi and Bloch [10], [11].

The usefulness of exploiting states for secrecy has been extensively investigated in the context of state-dependent wiretap channels. A discrete memoryless wiretap channel with random states known non-causally at the transmitter was first studied by Chen and Vinck [12], who established a lower bound on the secrecy capacity based on a combination of wiretap coding with Gel'fand-Pinsker coding. Generally speaking, coding schemes with Channel State Information (CSI) outperform those without CSI because perfect knowledge of the CSI not only enables the transmitter to beamform its signal toward the legitimate receiver but also provides a source of common randomness from which to generate a common secret key and enhance secrecy rates. Khisti *et al.* [13] studied the problem of secret key generation from non-causal channel state available at the transmitter and established inner and outer bounds on the secret key capacity. Chia and El Gamal [14] studied a wiretap channel in which the state information is available causally at both transmitter and receiver, proposing a scheme in which the transmitter and the receiver extract a weakly secret key from the state and protect the confidential message via a one-time-pad driven with the extracted key (see also [15] and [16]). Han and Sasaki [17] subsequently extended this result to achieve strong secrecy. Goldfeld *et al.* [18] proposed a superposition coding scheme for the problem of transmitting a semantically secure message over a state-dependent channel while the channel state is available non-causally at the transmitter.

This paper studies covert communication over a state-dependent discrete memoryless channel with channel state available either non-causally, causally, or strictly causally, either at both the transmitter and the receiver or at the transmitter alone (see Fig. 1). One of the main contributions of this work is to show that the channel state can be used to simultaneously and efficiently accomplish two necessary tasks: using the channel state for a Shannon strategy or Gel'fand-Pinsker coding, while also extracting a shared secret key at the two legitimate terminals to resolve the multiple codebooks that are necessary for covert communication. Secret key extraction from channel states replaces the external secret key in other models, thus generalizing and expanding the applicability of covert communication. A preliminary version of the results of this paper appeared in [19], [20].

We characterize the exact covert capacity when CSI is available at both the transmitter and the receiver, and derive

inner and outer bounds on the covert capacity when channel state information is only available at the transmitter. For some channel models for which the covert capacity is zero without channel state information, we show that the covert capacity is positive with channel state information. The code constructions behind our proofs combine different coding mechanisms, including channel resolvability for covertness, channel randomness extraction for key generation, and Gel'fand-Pinsker coding for state-dependent channels. The key technical challenge consists in properly combining these mechanisms to ensure the overall covertness of the transmission through block-Markov chaining schemes. In the interest of brevity, the proofs that are more standard, or parallel other proofs in this paper, are omitted from the paper and made available online on arXiv [21], as well as in a supplement provided with the submission.

II. PRELIMINARIES

Here, \mathbb{N} is the set of natural numbers, which does not include 0, while \mathbb{R} denotes the real numbers. Also, we define $\mathbb{R}_+ = \{x \in \mathbb{R} | x \geq 0\}$ and $\mathbb{R}_{++} = \mathbb{R}_+ \setminus \{0\}$. Throughout this paper, random variables are denoted by capital letters and their realizations by lower case letters. The set of ϵ -strongly jointly typical sequences of length n , according to $P_{X,Y}$, is denoted by $\mathcal{T}_\epsilon^{(n)}(P_{X,Y})$. For convenience, typicality will reference the random variables rather than the distribution, e.g., we write $\mathcal{T}_\epsilon^{(n)}(X, Y)$ or $\mathcal{T}_\epsilon^{(n)}(X|Y)$. Superscripts denote the dimension of a vector, e.g., X^n . The integer set $\{1, \dots, M\}$ is denoted by $\llbracket 1 : M \rrbracket$, X_i^j indicates the set $\{X_i, X_{i+1}, \dots, X_j\}$, and $X_{\sim i}^n$ denotes the vector X^n except X_i . The cardinality of a set is denoted by $|\cdot|$. The total variation between Probability Mass Function (PMF) P and PMF Q is defined as $\|P - Q\|_1 = \frac{1}{2} \sum_x |P(x) - Q(x)|$ and the Kullback-Leibler (KL) divergence between PMFs is defined as $\mathbb{D}(P||Q) = \sum_x p(x) \log \frac{P(x)}{Q(x)}$. The support of a probability distribution P is denoted by $\text{supp}(P)$. The n -fold product distribution constructed from the same distribution P is denoted $P^{\otimes n}$. Throughout the paper, \log denotes the base 2 logarithm. $\mathbb{E}_{\mathcal{A}}(\cdot)$ is the expectation with respect to the all random variable in \mathcal{A} except the one with index $i \in \mathcal{A}$, for a set of random variables $\{X_i\}_{i \in \mathcal{A}}$ indexed over a countable set \mathcal{A} . Also, $\mathbb{E}_X(\cdot)$ is the expectation w.r.t. the random variable X and $\mathbb{1}_{\{\cdot\}}$ denotes the indicator function.

Consider a discrete memoryless state-dependent channel as shown in Fig. 1. \mathcal{X} is the channel input, \mathcal{Y} and \mathcal{Z} are the channel outputs at the legitimate receiver and the warden, respectively. Let $x_0 \in \mathcal{X}$ be an innocent symbol corresponding to the absence of communication with the receiver. We assume that the channel state is independent and identically distributed (i.i.d.) and drawn according to Q_S . Define

$$Q_0(\cdot) = \sum_{s \in \mathcal{S}} Q_S(s) W_{Z|X,S}(\cdot | x_0, s), \quad (1)$$

$$Q_Z(\cdot) = \sum_{s \in \mathcal{S}} \sum_{x \in \mathcal{X}} Q_S(s) P_{X|S}(x|s) W_{Z|X,S}(\cdot | x, s) \quad (2)$$

and let $Q_0^{\otimes n} = \prod_{i=1}^n Q_0$ and also let $Q_Z^{\otimes n} = \prod_{i=1}^n Q_Z$. The channel state can be available non-causally, causally, or strictly causally either at both the transmitter and the receiver, or only at the transmitter, but not to the warden. An $(|\mathcal{M}|, n)$ code consists of an encoder-decoder pair, as follows. The encoder maps $(M, S^n) \rightarrow X^n \in \mathcal{X}^n$ when CSI is available non-causally at the transmitter, $(M, S^i) \rightarrow X_i \in \mathcal{X}$ when CSI is available causally, and $(M, S^{i-1}) \rightarrow X_i \in \mathcal{X}$ when the CSI is available strictly causally at the transmitter. The decoder maps $(S^n, Y^n) \rightarrow \hat{M} \in \mathcal{M}$ when CSI is available at both the transmitter and the receiver, and $Y^n \rightarrow \hat{M} \in \mathcal{M}$ when CSI is only available at the transmitter. The code is assumed known to all parties and the objective is to design a code that is both reliable and covert. The code is defined to be reliable if the probability of error $P_e^{(n)} = \mathbb{P}(\hat{M} \neq M)$ goes to zero when

$n \rightarrow \infty$. The code is covert if the warden cannot determine whether communication is happening (hypothesis H_1) or not (hypothesis H_0). The probabilities of false alarm (warden deciding H_1 when H_0 is true) and missed detection (warden deciding H_0 when H_1 is true), are denoted by α_n and β_n , respectively. An uninformed, random decision by the warden satisfies $\alpha_n + \beta_n = 1$, which is the benchmark for covertness. When the channel carries communication, the warden's channel output distribution is denoted P_{Z^n} , and the optimal hypothesis test by the warden satisfies $\alpha_n + \beta_n \geq 1 - \sqrt{\mathbb{D}(P_{Z^n} || Q_0^{\otimes n})}$ [22]. Therefore, to show that the communication is covert, it suffices to show that $\mathbb{D}(P_{Z^n} || Q_0^{\otimes n}) \rightarrow 0$. Note that $\text{supp}(Q_0) = \mathcal{Z}$ otherwise $\mathbb{D}(P_{Z^n} || Q_0^{\otimes n}) \rightarrow \infty$. Here, we assume Q_0 has full support (i.e. does not put zero mass on some point). Consequently, our goal is to design a sequence of $(2^{nR}, n)$ codes such that

$$\lim_{n \rightarrow \infty} P_e^{(n)} = 0, \quad (3a)$$

$$\lim_{n \rightarrow \infty} \mathbb{D}(P_{Z^n} || Q_0^{\otimes n}) = 0. \quad (3b)$$

We define the covert capacity as the supremum of all achievable covert rates and denote it by $C_{\text{NC-TR}}$ for non-causal CSI available at both the transmitter and the receiver, $C_{\text{NC-T}}$ for non-causal CSI only available at the transmitter, $C_{\text{C-TR}}$ for causal CSI available at both the transmitter and the receiver, $C_{\text{C-T}}$ for causal CSI available only at the transmitter, $C_{\text{SC-TR}}$ and $C_{\text{SC-T}}$ for strictly causal CSI available at both the transmitter and the receiver and strictly causal CSI only available at the transmitter, respectively. Note that, for the receiver's side availability of the non-causal, causal, and strictly causal CSI does not make any difference because decoding is always done after transmission is completed. However, at the transmitter's side availability of the non-causal, causal, and strictly causal CSI changes the problem because for these cases the transmitter can use the CSI in different manners. Before stating the main results, we state a useful lemma about the relation between the total variation distance and the KL-divergence.

Lemma 1 (Reverse Pinsker's Inequality [23, eq. (323)]). *Pinsker's inequality indicates that KL-divergence is larger than total variation distance, i.e. for two arbitrary distributions P and Q on alphabet \mathcal{A} such that P is absolutely continuous with respect to Q we have,*

$$\|P - Q\|_1 \leq \sqrt{\frac{1}{2} \mathbb{D}(P || Q)}. \quad (4)$$

A reverse inequality is valid when the alphabet \mathcal{A} is finite. Let P and Q be two arbitrary distributions on a finite alphabet set \mathcal{A} such that P is absolutely continuous with respect to Q . If $\mu \triangleq \min_{a \in \mathcal{Q}: Q(a) > 0} Q(a)$, we have,

$$\mathbb{D}(P || Q) \leq \log \left(\frac{1}{\mu} \right) \|P - Q\|_1. \quad (5)$$

III. CHANNEL STATE INFORMATION AT THE TRANSMITTER AND THE RECEIVER

A. Non-causal Channel State Information

Theorem 1. *Let*

$$\mathcal{S} \triangleq \{R \geq 0 : \exists P_{S,X,Y,Z} \in \mathcal{D} \text{ such that } R \leq \mathbb{I}(X; Y | S)\} \quad (6a)$$

where,

$$\mathcal{D} \triangleq \left\{ \begin{array}{l} P_{S,X,Y,Z} : \\ P_{S,X,Y,Z} = Q_S P_{X|S} W_{Y,Z|S,X} \\ P_Z = Q_0 \\ \mathbb{H}(S|Z) > \mathbb{I}(X; Z|S) - \mathbb{I}(X; Y|S) \end{array} \right\}. \quad (6b)$$

The covert capacity of the DMC $W_{Y,Z|S,X}$ with non-causal CSI at both the transmitter and the receiver is

$$C_{\text{NC-TR}} = \max\{x : x \in \mathcal{S}\}. \quad (7)$$

Remark 1 (Interpretation). *Theorem 1 suggests that the key rate that one can extract from channel state (i.e. $H(S|Z)$) should be at least as large as the difference between the capacity of the warden and the capacity of the legitimate receiver.*

The achievability is proved by superposition encoding. The proof is available in Appendix A.

B. Causal Channel State Information

Theorem 2. *Let*

$$\mathcal{S} \triangleq \{R \geq 0 : \exists P_{S,U,X,Y,Z} \in \mathcal{D} \text{ such that } R \leq \mathbb{I}(U; Y|S)\} \quad (8a)$$

where,

$$\mathcal{D} \triangleq \left\{ \begin{array}{l} P_{S,U,X,Y,Z} : \\ P_{S,U,X,Y,Z} = Q_S P_U \mathbb{1}_{\{X=X(U,S)\}} W_{Y,Z|S,X} \\ P_Z = Q_0 \\ \mathbb{H}(S|Z) > \mathbb{I}(U; Z|S) - \mathbb{I}(U; Y|S) \\ |\mathcal{U}| \leq |\mathcal{X}| + 1 \end{array} \right\}. \quad (8b)$$

The covert capacity of the DMC $W_{Y,Z|S,X}$ with causal CSI at both the transmitter and the receiver is

$$C_{\text{C-TR}} = \max\{x : x \in \mathcal{S}\}. \quad (9)$$

Remark 2 (Interpretation). *Theorem 2 suggests that the key rate that we extract from channel state (i.e. $H(S|Z)$) should be at least as large as the difference between the capacity of the warden and the capacity of the legitimate receiver.*

The proof is based on block Markov encoding and Shannon strategy for transmitting the message according to CSI. In order to use the CSI simultaneously for both Shannon strategy and key generation we design a block Markov encoding scheme. In this scheme, the transmitter not only generates a key from S^n but also selects its codeword according to S^n to help transmitting the message. The proof is available in Appendix B.

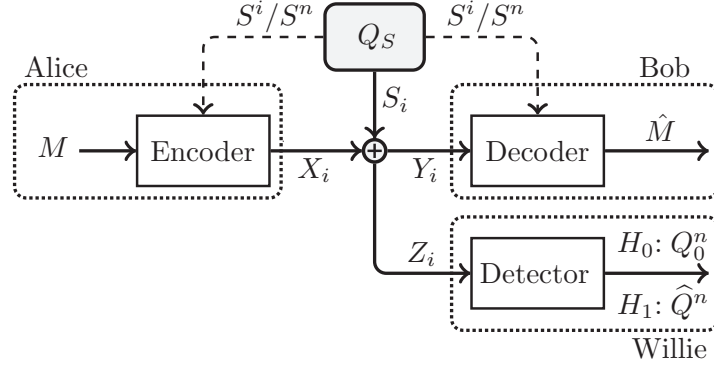

Fig. 2. Binary symmetric channel with additive CSI at the transmitter and the receiver

C. Strictly Causal Channel State Information

We now consider the case in which strictly causal channel state information is available at both the transmitter and the receiver. Even though *strictly* causal channel state information is more restricted, it is still useful because the shared randomness can still be used to mislead the warden.

Theorem 3. *Let*

$$\mathcal{S} \triangleq \{R \geq 0 : \exists P_{S,X,Y,Z} \in \mathcal{D} \text{ such that } R \leq \mathbb{I}(X; Y|S)\} \quad (10a)$$

where,

$$\mathcal{D} \triangleq \left\{ \begin{array}{l} P_{S,X,Y,Z} : \\ P_{S,X,Y,Z} = Q_S P_X W_{Y,Z|S,X} \\ P_Z = Q_0 \\ \mathbb{H}(S|Z) > \mathbb{I}(X; Z|S) - \mathbb{I}(X; Y|S) \end{array} \right\}. \quad (10b)$$

The covert capacity of the DMC $W_{Y,Z|S,X}$ with strictly causal CSI at both the transmitter and the receiver is

$$C_{\text{SC-TR}} = \max\{x : x \in \mathcal{S}\}. \quad (11)$$

To prove the achievability of Theorem 3, we merely use the channel state information for key generation and not for data transmission by using a block Markov encoding scheme. The proof is available in Appendix C.

IV. EXAMPLES

We provide two examples of covert communication without an external secret key, while surpassing the square-root- n performance with a positive rate. The two examples explore additive and multiplicative channel states, respectively. The former represents channels in which state can in principle be cancelled, while the latter represents fading-like states.

Table 1
JOINT PROBABILITY DISTRIBUTION OF X, S

$X \backslash S$	0	1
0	α	β
1	$1 - \alpha - \beta - \eta$	η

A. Binary Additive State

Consider a channel in which X, Y, Z , and S are all binary, Q_s obeys a Bernoulli distribution with parameter $\zeta \in (0, 0.5)$, and the innocent symbol is $x_0 = 0$. (See Fig. 2). The law of the channel is

$$Y = Z = X \oplus S. \quad (12)$$

Proposition 1. *The covert capacity of the DMC depicted in Fig. 2 with causal or non-causal CSI available at the transmitter and the receiver is*

$$C_{\text{NC-TR}} = C_{\text{C-TR}} = \mathbb{H}_b(\zeta) = \zeta \log \frac{1}{\zeta} + (1 - \zeta) \log \frac{1}{1 - \zeta}, \quad (13)$$

if $\mathbb{H}(S|Z) > 0$.

Intuitively, because the encoder knows the CSI, it can perfectly control the warden's observation. By manipulating X the encoder can ensure Z follows the statistics of S . In part, this means the set of symbols $X = 1$ correspond half to $S = 0$ and half to $S = 1$, ensuring $Q_S \sim \text{Bern}(\zeta) = P_Z$. Further, since the transmitter and receiver share the CSI, the legitimate channel is error-free.

Proof. First we proof Proposition 1 when channel state is available non-causally at both the transmitter and the receiver. Substituting $Y = Z = X \oplus S$ in Theorem 1 results in

$$C_{\text{NC-TR}} = \max_{Q_S P_{X|S}} \mathbb{H}(X|S), \quad (14)$$

such that $P_Z = Q_0$. Since $x_0 = 0$ we have $Q_0 = Q_S$. Let the joint distribution between X and S be according to Table 1, we have

$$P_Z(z = 0) = P_{X,S}(x = 0, s = 0) + P_{X,S}(x = 1, s = 1) = \alpha + \eta, \quad (15)$$

$$Q_S(s = 0) = P_{X,S}(x = 0, s = 0) + P_{X,S}(x = 1, s = 0) = \alpha + \beta. \quad (16)$$

Therefore $P_Z = Q_S$ implies that

$$Q_Z(z = 0) = Q_S(s = 0) \Rightarrow \alpha + \eta = \alpha + \beta \Rightarrow \eta = \beta. \quad (17)$$

Therefore,

$$\begin{aligned} \max_{Q_S P_{X|S}} \mathbb{H}(X|S) &= \max_{\substack{(\alpha, \beta) \\ \zeta = \alpha + \beta}} \left[-\alpha \log \frac{\alpha}{\alpha + \beta} - (1 - \alpha - 2\beta) \log \frac{1 - \alpha - 2\beta}{1 - \alpha - \beta} \right. \\ &\quad \left. - \beta \log \frac{\beta}{\alpha + \beta} - \beta \log \frac{\beta}{1 - \alpha - \beta} \right]. \end{aligned} \quad (18)$$

Considering $Q_S(s = 0) = \zeta = \alpha + \beta$ and substituting $\beta = \zeta - \alpha$ in (18) results in

$$\max_{Q_S P_{X|S}} \mathbb{H}(X|S) = \max_{\alpha} \left[-\alpha \log \frac{\alpha}{\zeta} - (1 + \alpha - 2\zeta) \log \frac{1 + \alpha - 2\zeta}{1 - \zeta} \right]$$

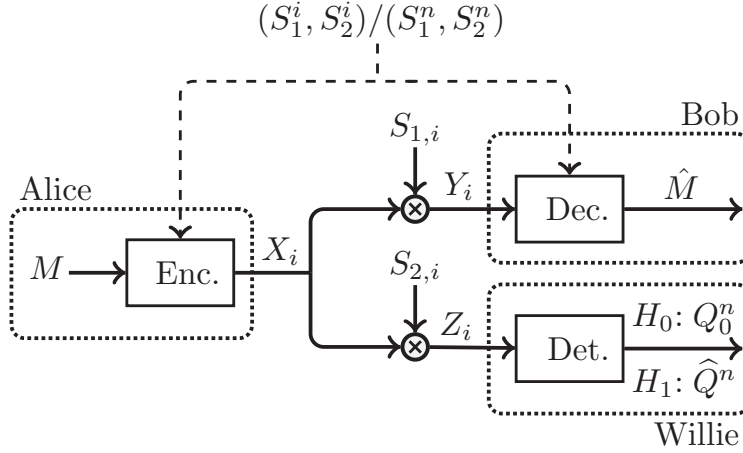

Fig. 3. Binary symmetric channel with multiplicative CSI at the transmitter and the receiver

$$- (\zeta - \alpha) \log \frac{\zeta - \alpha}{\zeta} - (\zeta - \alpha) \log \frac{\zeta - \alpha}{1 - \zeta}]. \quad (19)$$

Since entropy is a continuous concave function, the maximizer of $\mathbb{H}(X|S)$ is found at the root of the first derivative of (19). This root is $\alpha = \zeta^2$, resulting in $\max \mathbb{H}(X|S) = \mathbb{H}(S)$. Since $Y = Z$, the condition $\mathbb{H}(S|Z) > \mathbb{I}(X; Z|S) - \mathbb{I}(X; Y|S)$ reduces to $\mathbb{H}(S|Z) > 0$. If $\mathbb{H}(S|Z) = 0$ the rate of covert communication between the legitimate terminals will be zero because the warden can recover S from Z and the problem reduces to covert communication for point to point channel.

We now proof Proposition 1 when channel state is available causally at both the transmitter and the receiver. We assume that U is a Bernoulli random variable with parameter $\eta \in (0, 0.5)$. Here, U and S are independent. To prove the achievability for the causal case, we choose $X = U \oplus S$ therefore $Y = Z = U$ and $\mathbb{I}(U; Y|S) = \mathbb{H}(U)$. Since $x_0 = 0$ we have $Q_0 = Q_S$ and the condition $Q_Z = Q_0$ results in $\eta = \zeta$ this follows because

$$Q_S(z = 0) = \mathbb{P}(s = 0) = \zeta, \quad (20)$$

$$Q_Z(z = 0) = \mathbb{P}(u = 0) = \eta. \quad (21)$$

Therefore the covert capacity is equal to $\mathbb{H}_b(\zeta)$. Again since $Y = Z$, the condition $\mathbb{H}(S|Z) > \mathbb{I}(U; Z|S) - \mathbb{I}(U; Y|S)$ reduces to $\mathbb{H}(S|Z) > 0$. If $\mathbb{H}(S|Z) = 0$ the rate of covert communication between the legitimate terminals will be zero because the warden can recover S from Z and the problem reduces to covert communication for point to point channel. The proof for the upper bound comes from the fact that the covert communication rate for the causal case cannot be higher than the non-causal case. \square

B. Binary Multiplicative State

Consider a channel in which X, Y, Z, S_1 , and S_2 are all binary and S_1 and S_2 have a joint distribution with parameters $P(S_1 = i, S_2 = j) = p_{i,j}$, for $i, j \in \{0, 1\}$ and the innocent symbol is $x_0 = 0$ (See Fig. 3). The law of the channel is

$$Y = X \otimes S_1, \quad Z = X \otimes S_2. \quad (22)$$

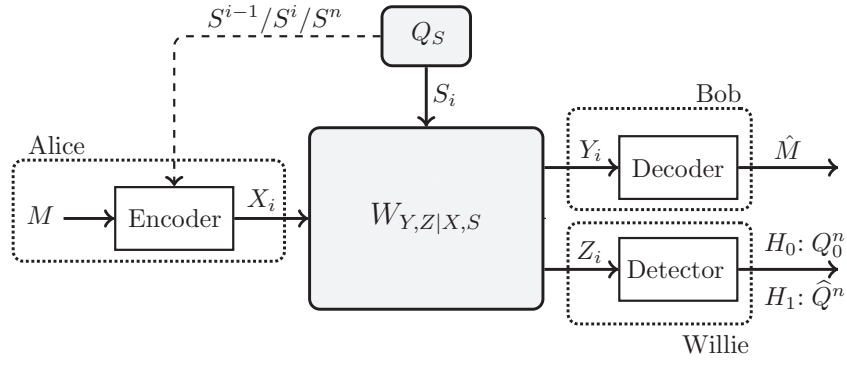

Fig. 4. Model of covert communication over state-dependent DMC when CSI is only available at the transmitter

Proposition 2. *The covert capacity of the DMC depicted in Fig. 3 with causal or non-causal CSI available at the transmitter and the receiver is*

$$C_{\text{NC-TR}} = C_{\text{C-TR}} = p_{1,0}. \quad (23)$$

Intuitively, covert communication occurs when the warden's observation is blocked by a bad channel state while simultaneously the legitimate receiver is enjoying a good channel state. Since the receiver has access to CSI, the legitimate channel is effectively noise-free.

Proof. We proof Proposition 2 for the non-causal case, the proof for the causal case is similar to the non-causal case and it's omitted for brevity. In Theorem 1, by substituting $S = (S_1, S_2)$,

$$\begin{aligned} C_{\text{NC-TR}} &= \max_{\substack{P_{X|S_1, S_2}, \\ Q_Z = Q_0}} [\mathbb{I}(X; Y | S_1, S_2)] \\ &= \max_{\substack{P_{X|S_1, S_2}, \\ Q_Z = Q_0}} \left[\sum_{i=0}^1 \sum_{j=0}^1 p_{i,j} \mathbb{I}(X; Y | S_1 = i, S_2 = j) \right] \\ &\stackrel{(a)}{=} \max_{P_{X|S_1, S_2}} \left[p_{1,0} \mathbb{I}(X; Y | s_1 = 1, s_2 = 0) \right] \\ &= \max_{P_{X|S_1, S_2}} \left[p_{1,0} \mathbb{H}(X | s_1 = 1, s_2 = 0) \right] \\ &= p_{1,0}, \end{aligned} \quad (24)$$

where (a) holds because when $S_1 = 0$, communication is prohibited because Y is annihilated, and when $S_2 = 1$, we have $Z = X$ therefore $P_X = P_Z = Q_0$, and once again there can be no communication. Also, Z always equal to zero implies that $\mathbb{I}(X; Z | S) \leq \mathbb{H}(Z) = 0$ and therefore the condition $\mathbb{H}(S | Z) > \mathbb{I}(X; Z | S) - \mathbb{I}(X; Y | S)$ is satisfied. \square

V. CHANNEL STATE INFORMATION ONLY AT THE TRANSMITTER

Fig. 4 depicts covert communication with channel state available at the transmitter (but not the receiver). We proceed to discuss the effects of non-causal, causal, and strictly causal CSI at the transmitter.

A. Non-Causal CSI

Theorem 4. *Let*

$$\mathcal{S} \triangleq \{R \geq 0 : \exists P_{U,V,S,X,Y,Z} \in \mathcal{D} \text{ such that } R \leq \mathbb{I}(U; Y) - \max\{\mathbb{I}(U; S), \mathbb{I}(U, V; S) - \mathbb{I}(V; Y|U)\}\} \quad (25a)$$

where,

$$\mathcal{D} \triangleq \left\{ \begin{array}{l} P_{U,V,S,X,Y,Z} : \\ P_{U,V,S,X,Y,Z} = P_U P_V P_{S|U,V} \mathbb{1}_{\{X=X(U,S)\}} W_{Y,Z|X,S} \\ Q_S(\cdot) = \sum_{u \in \mathcal{U}} \sum_{v \in \mathcal{V}} P_U(u) P_V(v) P_{S|U,V}(\cdot|u,v) \\ P_Z = Q_0 \\ \mathbb{I}(V; Y|U) > \max\{\mathbb{I}(V; Z), \mathbb{I}(U, V; Z) - \mathbb{I}(U; Y)\} \\ |\mathcal{U}| \leq |\mathcal{X}| + 5 \\ |\mathcal{V}| \leq |\mathcal{X}| + 3 \end{array} \right\}. \quad (25b)$$

The covert capacity of the DMC $W_{Y,Z|S,X}$ with non-causal CSI at the transmitter is lower-bounded as

$$C_{\text{NC-T}} \geq \max\{x : x \in \mathcal{S}\}. \quad (26)$$

The proof is based on block Markov encoding, Gel'fand-Pinsker coding for transmitting the message according to CSI [24], and Wyner-Ziv coding for secret key generation [25]. To use the CSI for both Gel'fand-Pinsker encoding and key generation we design a block Markov encoding scheme. In this scheme, the transmitter not only generates a key from S^n but also selects its codeword according to S^n by using a likelihood encoder [26]–[28]. Here, instead of generating a secret key directly from the CSI we generate a secret key from another random variable which is correlated with CSI. This helps to control the rate of the secret key that is generated from the CSI, because sometimes a shared key between the legitimate terminals is not needed for covert communication. For example, consider the case where the legitimate receiver's channel is a less noisy version of the warden's channel (see Corollary 1). Also, this arrangement helps the legitimate terminals to generate the secret key from the CSI more efficiently (see Section VI-B). To generate a secret key from a random variable which is correlated with CSI we use Wyner-Ziv encoding. Proof details are available in Appendix D.

Theorem 5. *Let*

$$\mathcal{S} \triangleq \{R \geq 0 : \exists P_{S,U,X,Y,Z} \in \mathcal{D} \text{ such that } R \leq \mathbb{I}(U; Y) - \mathbb{I}(U; S)\} \quad (27a)$$

where,

$$\mathcal{D} \triangleq \left\{ \begin{array}{l} P_{S,U,X,Y,Z} : \\ P_{S,U,X,Y,Z} = Q_S P_{U|S} \mathbb{1}_{\{X=X(U,S)\}} W_{Y,Z|X,S} \\ P_Z = Q_0 \\ \mathbb{I}(U; Y) > \mathbb{I}(U; Z) \\ |\mathcal{U}| \leq |\mathcal{X}| + 2 \end{array} \right\}. \quad (27b)$$

The covert capacity of the DMC $W_{Y,Z|S,X}$ with non-causal CSI at the transmitter is lower-bounded as

$$C_{\text{NC-T}} \geq \max\{x : x \in \mathcal{S}\}. \quad (28)$$

The proof uses Gel'fand-Pinsker coding with likelihood encoder, *without* block-Markov encoding or key generation from CSI. Theorem 5 can also be proved by using Theorem 4 while generating S independent of V (i.e. $P_{S|U,V} = P_{S|U}$). The independence between V and S implies $\mathbb{I}(V; S) = 0$ and $\mathbb{I}(V; U, Y) = 0$ which results in the region in Theorem 5. Proof details are available in Appendix F.

Remark 3 (Comparison Between Theorems 4 and 5). *Theorems 4 and 5 introduce two achievable schemes for the same problem (non-causal CSI at transmitter). While the expression in (25a) is not larger than (27a) when calculated for the same probability distribution, the set of admissible probability distributions defined by (25b) may contain distributions not in (27b).*

Theorem 6. *Let*

$$\mathcal{S} \triangleq \{R \geq 0 : \exists P_{S,U,V,X,Y,Z} \in \mathcal{D} \text{ such that } R \leq \min\{\mathbb{I}(U; Y) - \mathbb{I}(U; S), \mathbb{I}(U, V; Y) - \mathbb{I}(U; S|V)\}\} \quad (29a)$$

where,

$$\mathcal{D} \triangleq \left\{ \begin{array}{l} P_{S,U,V,X,Y,Z} : \\ P_{S,U,V,X,Y,Z} = Q_S P_{UV|S} \mathbb{1}_{\{X=X(U,S)\}} W_{Y,Z|X,S} \\ P_Z = Q_0 \\ \min\{\mathbb{I}(U; Y) - \mathbb{I}(U; S), \mathbb{I}(U, V; Y) - \mathbb{I}(U; S|V)\} \geq \mathbb{I}(V; Z) - \mathbb{I}(V; S) \\ \max\{|\mathcal{U}|, |\mathcal{V}|\} \leq |\mathcal{X}| + 3 \end{array} \right\}. \quad (29b)$$

The covert capacity of the DMC $W_{Y,Z|S,X}$ with non-causal CSI at the transmitter is upper-bounded as

$$C_{\text{NC-T}} \leq \max\{x : x \in \mathcal{S}\}. \quad (30)$$

Proof details are available in Appendix G.

Corollary 1. *Let*

$$\mathcal{S} \triangleq \{R \geq 0 : \exists P_{S,U,X,Y,Z} \in \mathcal{D} \text{ such that } R \leq \mathbb{I}(U; Y) - \mathbb{I}(U; S)\} \quad (31a)$$

where,

$$\mathcal{D} \triangleq \left\{ \begin{array}{l} P_{S,U,X,Y,Z} : \\ P_{S,U,X,Y,Z} = Q_S P_{U|S} \mathbb{1}_{\{X=X(U,S)\}} W_{Y,Z|X,S} \\ P_Z = Q_0 \\ |\mathcal{U}| \leq |\mathcal{X}| + 2 \end{array} \right\}. \quad (31b)$$

The covert capacity of the less noisy channel $W_{Y,Z|X,S}$ (i.e. $\mathbb{I}(U; Y) \geq \mathbb{I}(U; Z)$) with CSI available non-causally only at the transmitter is,

$$C_{\text{NC-T}} = \max\{x : x \in \mathcal{S}\}. \quad (32)$$

Proof. The achievability is proved by using Theorem 5 and the less noisy property of the channel. We can also proof the achievability by using Theorem 4 while generating S independent of V (i.e. $P_{S|U,V} = P_{S|U}$) and the less noisy property of the channel. Furthermore, the converse is proved by utilizing Theorem 6 and the less noisy property of the channel. \square

B. Causal CSI

Theorem 7. *Let*

$$\mathcal{S} \triangleq \{R \geq 0 : \exists P_{U,V,S,X,Y,Z} \in \mathcal{D} \text{ such that } R \leq \mathbb{I}(U; Y) + \min\{0, \mathbb{I}(V; Y|U) - \mathbb{I}(V; S)\}\} \quad (33a)$$

where,

$$\mathcal{D} \triangleq \left\{ \begin{array}{l} P_{U,V,S,X,Y,Z} : \\ P_{U,V,S,X,Y,Z} = P_U P_V P_{S|V} \mathbb{1}_{\{X=X(U,S)\}} W_{Y,Z|X,S} \\ Q_S(\cdot) = \sum_{v \in \mathcal{V}} P_V(v) P_{S|V}(\cdot|v) \\ P_Z = Q_0 \\ \mathbb{I}(V; Y|U) > \max\{\mathbb{I}(V; Z), \mathbb{I}(U, V; Z) - \mathbb{I}(U; Y)\} \\ |\mathcal{U}| \leq |\mathcal{X}| + 2 \\ |\mathcal{V}| \leq |\mathcal{X}| + 3 \end{array} \right\}. \quad (33b)$$

The covert capacity of the DMC $W_{Y,Z|S,X}$ with causal CSI at the transmitter is lower-bounded as

$$C_{C-T} \geq \max\{x : x \in \mathcal{S}\}. \quad (34)$$

Theorem 7 is proved by a block Markov encoding, Shannon strategy for sending the message according to CSI, and Wyner-Ziv coding for secret key generation. We design a block Markov coding scheme in which the transmitter not only generates a key from S^n but also selects its codeword according to S^n . The details of the proof are available in Appendix J.

Theorem 8. *Let*

$$\mathcal{S} \triangleq \{R \geq 0 : \exists P_{S,U,X,Y,Z} \in \mathcal{D} \text{ such that } R \leq \mathbb{I}(U; Y)\} \quad (35a)$$

where,

$$\mathcal{D} \triangleq \left\{ \begin{array}{l} P_{S,U,X,Y,Z} : \\ P_{S,U,X,Y,Z} = Q_S P_U \mathbb{1}_{\{X=X(U,S)\}} W_{Y,Z|X,S} \\ P_Z = Q_0 \\ \mathbb{I}(U; Y) > \mathbb{I}(U; Z) \\ |\mathcal{U}| \leq |\mathcal{X}| + 1 \end{array} \right\}. \quad (35b)$$

The covert capacity of the DMC $W_{Y,Z|S,X}$ with causal CSI at the transmitter is lower-bounded as

$$C_{C-T} \geq \max\{x : x \in \mathcal{S}\}. \quad (36)$$

The details of the proof are available in Appendix K.

Theorem 9. *Let*

$$\mathcal{S} \triangleq \{R \geq 0 : \exists P_{S,U,V,X,Y,Z} \in \mathcal{D} \text{ such that } R \leq \mathbb{I}(U; Y)\} \quad (37a)$$

where,

$$\mathcal{D} \triangleq \left\{ \begin{array}{l} P_{S,U,V,X,Y,Z} : \\ P_{S,U,V,X,Y,Z} = Q_S P_V P_{U|V} \mathbb{1}_{\{X=X(U,S)\}} W_{Y,Z|X,S} \\ P_Z = Q_0 \\ \mathbb{I}(U; Y) \geq \mathbb{I}(V; Z) \\ \max\{|\mathcal{U}|, |\mathcal{V}|\} \leq |\mathcal{X}| \end{array} \right\}. \quad (37b)$$

The covert capacity of the DMC $W_{Y,Z|S,X}$ with causal CSI at the transmitter is upper-bounded as

$$C_{C-T} \leq \max\{x : x \in \mathcal{S}\}. \quad (38)$$

Proof details are available in Appendix L.

Corollary 2. *Let*

$$\mathcal{S} \triangleq \{R \geq 0 : \exists P_{S,U,X,Y,Z} \in \mathcal{D} \text{ such that } R \leq \mathbb{I}(U; Y)\} \quad (39a)$$

where,

$$\mathcal{D} \triangleq \left\{ \begin{array}{l} P_{S,U,X,Y,Z} : \\ P_{S,U,X,Y,Z} = Q_S P_U \mathbb{1}_{\{X=X(U,S)\}} W_{Y,Z|X,S} \\ P_Z = Q_0 \\ |\mathcal{U}| \leq |\mathcal{X}| + 1 \end{array} \right\}. \quad (39b)$$

The covert capacity of the less noisy channel $W_{Y,Z|X,S}$ (i.e. $\mathbb{I}(U; Y) \geq \mathbb{I}(U; Z)$) with CSI available causally only at the transmitter is,

$$C_{C-T} = \max\{x : x \in \mathcal{S}\}. \quad (40)$$

Proof. The achievability is proved by using Theorem 8 and the less noisy property of the channel. We can also prove the achievability by using Theorem 7 while generating S independent of V (i.e. $P_{S|V} = Q_S$) and the less noisy property of the channel. Furthermore, the converse is proved by utilizing Theorem 9 and the less noisy property of the channel. \square

C. Strictly Causal CSI

The availability of strictly causal channel state information at the transmitter is useful because it provides a source of common randomness between the legitimate users, which can be used to generate a shared secret key between them to mislead the warden. Here, we only use the channel state information for key generation and not for data transmission.

Theorem 10. *Let*

$$\mathcal{S} \triangleq \{R \geq 0 : \exists P_{X,V,S,Y,Z} \in \mathcal{D} \text{ such that } R \leq \mathbb{I}(X; Y) + \min\{0, \mathbb{I}(V; Y|X) - \mathbb{I}(V; S)\}\} \quad (41a)$$

where,

$$\mathcal{D} \triangleq \left\{ \begin{array}{l} P_{X,V,X,Y,Z} : \\ P_{X,V,S,Y,Z} = P_X P_V P_{S|V} W_{Y,Z|X,S} \\ Q_S(\cdot) = \sum_{v \in \mathcal{V}} P_V(v) P_{S|V}(\cdot|v) \\ P_Z = Q_0 \\ \mathbb{I}(V; Y|X) > \max\{\mathbb{I}(V; Z), \mathbb{I}(X, V; Z) - \mathbb{I}(X; Y)\} \\ |\mathcal{V}| \leq |\mathcal{X}| + 3 \end{array} \right\}. \quad (41b)$$

The covert capacity of the DMC $W_{Y,Z|S,X}$ with strictly causal CSI at the transmitter is lower-bounded as

$$C_{\text{SC-T}} \geq \max\{x : x \in \mathcal{S}\}. \quad (42)$$

Proof details are available in Appendix M.

Theorem 11. *Let*

$$\mathcal{S} \triangleq \{R \geq 0 : \exists P_{S,X,Y,Z} \in \mathcal{D} \text{ such that } R \leq \mathbb{I}(X; Y)\} \quad (43a)$$

where,

$$\mathcal{D} \triangleq \left\{ \begin{array}{l} P_{S,X,Y,Z} : \\ P_{S,X,Y,Z} = Q_S P_X W_{Y,Z|X,S} \\ P_Z = Q_0 \\ \mathbb{I}(X; Y) > \mathbb{I}(X; Z) \end{array} \right\}. \quad (43b)$$

The covert capacity of the DMC $W_{Y,Z|S,X}$ with strictly causal CSI at the transmitter is lower-bounded as

$$C_{\text{SC-T}} \geq \max\{x : x \in \mathcal{S}\}. \quad (44)$$

Proof details are available in Appendix N. We now present an upper bound on the covert capacity when the CSI is available strictly causally at the transmitter.

Theorem 12. *Let*

$$\mathcal{S} \triangleq \{R \geq 0 : \exists P_{S,V,X,Y,Z} \in \mathcal{D} \text{ such that } R \leq \mathbb{I}(X; Y)\} \quad (45a)$$

where,

$$\mathcal{D} \triangleq \left\{ \begin{array}{l} P_{S,V,X,Y,Z} : \\ P_{S,V,X,Y,Z} = Q_S P_V P_{X|V} W_{Y,Z|X,S} \\ P_Z = Q_0 \\ \mathbb{I}(X; Y) \geq \mathbb{I}(V; Z) \\ |\mathcal{V}| \leq |\mathcal{X}| \end{array} \right\}. \quad (45b)$$

The covert capacity of the DMC $W_{Y,Z|S,X}$ with strictly causal CSI at the transmitter is upper-bounded as

$$C_{\text{SC-T}} \leq \max\{x : x \in \mathcal{S}\}. \quad (46)$$

Proof details are available in Appendix O.

Remark 4 (Strictly Causal CSI Does not Increase Capacity). *The segment of the proof culminating in (246) implies that strictly causal CSI does not increase the capacity of a point-to-point DMC. This result is known (e.g., see [29, Page 13]) but to the best of our knowledge no formal proof for it exists in the literature.*

Corollary 3. *Let*

$$\mathcal{S} \triangleq \{R \geq 0 : \exists P_{S,X,Y,Z} \in \mathcal{D} \text{ such that } R \leq \mathbb{I}(X;Y)\} \quad (47a)$$

where,

$$\mathcal{D} \triangleq \left\{ \begin{array}{l} P_{S,X,Y,Z} : \\ P_{S,X,Y,Z} = Q_S P_X W_{Y,Z|X,S} \\ P_Z = Q_0 \end{array} \right\}. \quad (47b)$$

The covert capacity when the channel is degraded (i.e. $W_{Y,Z|S,X} = W_{Y|S,X} W_{Z|Y}$) and CSI is available strictly causally at the transmitter is,

$$C_{\text{SC-T}} = \max\{x : x \in \mathcal{S}\}. \quad (48)$$

Proof. The achievability is proved by using Theorem 11 and the less noisy property of the channel. We can also proof the achievability by using Theorem 10 while generating S independent of V (i.e. $P_{S|V} = Q_S$) and the less noisy property of the channel. Furthermore, the converse is proved by utilizing Theorem 12 and the less noisy property of the channel. \square

Remark 5 (Cardinality Bounds). *The cardinality bounds on the auxiliary random variables in Theorems 2 to 10 follows by a standard application of the Eggleston-Fenchel-Carathéodory theorem [30, Theorem 18]. Details are omitted for brevity.*

VI. EXAMPLES

We provide two examples of covert communication without an external secret key, while surpassing the square-root- n performance with a positive rate. In both of the examples the channel state is additive however in the first example the warden's channel is a degraded version of the legitimate receiver's channel but in the second example the legitimate receiver's channel is a degraded version of the warden's channel. The second example shows that our proposed coding scheme with block-Markov encoding and Wyner-Ziv encoding for secret key generation can outperform the simple approach for deriving the covert rates.

A. Degraded Channel with Binary Additive State

We provide an example in which the covert capacity is positive. Consider a channel in which X, Y, Z and $S = (S_1, S_2)$ are all binary, and let S_1, S_2 , and U be independent Bernoulli random variables with parameters $\alpha \in [1:0.5]$, $\beta \in [1:0.5]$, and $\lambda \in [1:0.5]$, respectively, and let $x_0 = 0$ (See Fig. 5). Here, S_1 and S_2 are the channel states of the legitimate receiver's channel and the warden's channel, respectively, and U is an auxiliary

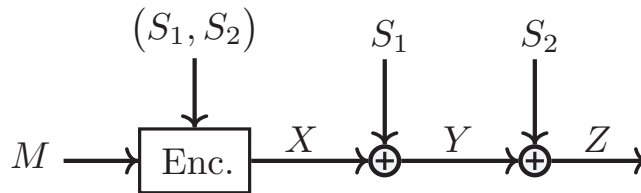

Fig. 5. Degraded channel with binary additive CSI at the transmitter

random variable that represents the message. The channel state information is available causally at the Encoder and the law of the channel is as follows

$$Y = X \oplus S_1, \quad (49)$$

$$Z = Y \oplus S_2. \quad (50)$$

Proposition 3. *The covert capacity of the DMC channel depicted in Fig. 5 with causal CSI at the transmitter is*

$$C_{C-T} \stackrel{(a)}{=} \max_{\substack{P_U, \\ P_Z=Q_0}} \mathbb{H}(U) \stackrel{(b)}{=} \mathbb{H}_b(\alpha) \quad (51)$$

where $\mathbb{H}_b(\cdot)$ is binary entropy.

Proof. The achievability proof for (a) follows from the achievability part of Corollary 2 and setting $X = U \oplus S_1$. The converse part of (a) follows from the converse part of Corollary 2 and the fact that $\mathbb{I}(U; Y) \leq \mathbb{H}(U)$. To prove (b) in Proposition 3, we have

$$\begin{aligned} Q_0(z = 0) &= P(s_1 \oplus s_2 = 0) \\ &= P(s_1 = 0, s_2 = 0) + P(s_1 = 1, s_2 = 1) \\ &= (1 - \alpha)(1 - \beta) + \alpha\beta. \end{aligned} \quad (52)$$

The distribution induced at the output of the warden when transmitting a codeword is

$$\begin{aligned} P_Z(z = 0) &= P(u \oplus s_2 = 0) \\ &= P(u = 0, s_2 = 0) + P(u = 1, s_2 = 1) \\ &= (1 - \lambda)(1 - \beta) + \lambda\beta. \end{aligned} \quad (53)$$

Therefore, the covertness constraint $P_Z = Q_0$ requires

$$\lambda = \alpha. \quad (54)$$

□

B. Reverse Degraded Channel with Binary Additive State

To show the efficiency of the proposed scheme in this paper, we provide an example in which the region in Theorem 7 results in a positive rate for covert communication while the region in Theorem 8 results in zero rate. Consider a channel in which X, Y, Z and $S = (S_1, S_2)$ are all binary, and let S_1, S_2 and U be independent Bernoulli random variables with parameters $\alpha \in (0:0.5]$, $\beta \in (0:0.5]$, and $\lambda \in (0:0.5]$, respectively, and let $x_0 = 0$ (See Fig. 6). Also, let V be a Bernoulli random variable. Here, S_1 and S_2 are the channel states of the warden's channel

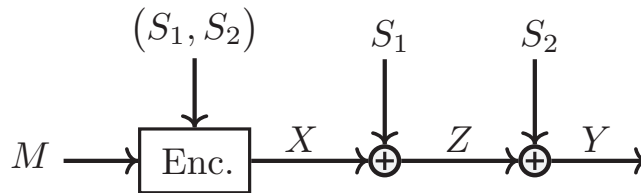

Fig. 6. Reverse degraded channel with binary additive CSI at the transmitter

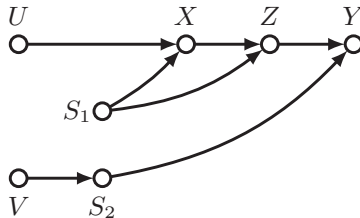

Fig. 7. Chaining between the random variables for reverse degraded channel with binary additive CSI

and the legitimate receiver's channel, respectively, U is an auxiliary random variable that represents the message, and V is an auxiliary random variable that represents a description of the CSI. The channel state information is available causally at the Encoder and the law of the channel is as follows

$$Z = X \oplus S_1, \quad (55)$$

$$Y = Z \oplus S_2. \quad (56)$$

Since for this example $\mathbb{I}(U; Z) \geq \mathbb{I}(U; Y)$, the achievable rate region in Theorem 8 results in zero rate but Theorem 7 results in the following region.

Proposition 4. *The covert capacity of the DMC channel depicted in Fig. 6 with causal CSI at the transmitter is lower bounded as*

$$C_{C-T} \geq \mathbb{H}_b(\eta) - \mathbb{H}_b(\beta), \quad (57)$$

where $\eta = \alpha\beta + (1 - \alpha)(1 - \beta)$.

Proof. Here we choose $X = U \oplus S_1$ therefore $Z = U$ and $Y = U \oplus S_2$. To proof the region in Proposition 4 by using Theorem 7, we start with covertness constraint $P_Z = Q_0$,

$$Q_0(z = 0) = \mathbb{P}(s_1 = 0) = \alpha, \quad (58)$$

$$P_Z(z = 0) = \mathbb{P}(u = 0) = \lambda. \quad (59)$$

Therefore, the covertness constraint requires $\lambda = \alpha$. We also choose $V = S_2$ therefore,

$$P_{V|S} = P_{V|S_1, S_2} = P_{V|S_2} = \mathbb{1}_{\{V=S_2\}}. \quad (60)$$

The chaining between the random variables for this example is depicted in Fig. 7. Now we show that the fourth condition in Theorem 7 which is the following conditions is satisfied,

$$\mathbb{I}(V; Y|U) > \mathbb{I}(V; Z), \quad (61)$$

$$\mathbb{I}(U, V; Y) > \mathbb{I}(U, V; Z). \quad (62)$$

We now have,

$$\begin{aligned} \mathbb{I}(V; Y|U) &= \mathbb{H}(S_2|U) - \mathbb{H}(S_2|U, Y) \\ &= \mathbb{H}(S_2) - \mathbb{H}(S_2|U, U \oplus S_2) \\ &= \mathbb{H}(S_2) = \mathbb{H}_b(\beta), \\ \mathbb{I}(V; Z) &= \mathbb{H}(S_2) - \mathbb{H}(S_2|U) \stackrel{(a)}{=} 0. \end{aligned}$$

where (a) follows since U and S_2 are independent. Therefore, the condition (61) is satisfied. For the condition in (62) we have,

$$\begin{aligned} \mathbb{I}(U, V; Y) &= \mathbb{H}(U, S_2) - \mathbb{H}(U, S_2|Y) \\ &= \mathbb{H}(U) + \mathbb{H}(S_2) - \mathbb{H}(U, S_2|U \oplus S_2) \\ &= \mathbb{H}(U) + \mathbb{H}(S_2) - \mathbb{H}(S_2|U \oplus S_2), \\ \mathbb{I}(U, V; Z) &= \mathbb{I}(U, S_2; U) = \mathbb{H}(U) \end{aligned}$$

since $\mathbb{H}(S_2) - \mathbb{H}(S_2|U \oplus S_2) > 0$ the condition in (62) is also satisfied. To calculate the covert rate (33a) in Theorem 7 we have,

$$\begin{aligned} \mathbb{I}(V; Y|U) &= \mathbb{H}_b(\beta), \\ \mathbb{I}(V; S) &= \mathbb{I}(S_2; S_1, S_2) \\ &= \mathbb{H}(S_2) = \mathbb{H}_b(\beta), \\ \mathbb{I}(U; Y) &= \mathbb{H}(Y) - \mathbb{H}(Y|U) \\ &= \mathbb{H}(U \oplus S_2) - \mathbb{H}(U \oplus S_2|U) \\ &= \mathbb{H}(U \oplus S_2) - \mathbb{H}(S_2) \\ &= \mathbb{H}_b(\eta) - \mathbb{H}_b(\beta), \end{aligned}$$

where $\eta = \alpha\beta + (1 - \alpha)(1 - \beta)$.

Remark 6 (Covertness vs. Security). *This example also captures the difference between covertness and security. Here the warden has noiseless access to the transmitted sequence and therefore it can decode the transmitted message, but since the transmitted sequence has the same statistics as the CSI it cannot prove that communication is happening.*

Remark 7 (Shared Key). *In the examples in this section, the codebooks are generated with the same distribution as the channel state S_1 therefore the legitimate terminals need to have access to a shared key of rate ϵ to discriminate the codewords from the CSI. Note that, in our achievability scheme for Theorem 7 the transmitter and the receiver have access to a shared secret key of rate ϵ therefore the legitimate terminals can use this shared key in the achievability scheme to discriminate the codewords from the CSI.*

□

VII. CONCLUSION

This paper studies keyless covert communication over state dependant channels, when the channel state information is available either at the transmitter alone, or at both the transmitter and receiver, but not to the adversary (warden). Our results show the feasibility of covertly communicating with a positive rate without an externally shared key between the transmitter and the receiver. This is in stark contrast with the known results showing that in the absence of channel state information, covert communication without a shared key is impossible at positive rates.

APPENDIX A

PROOF OF THEOREM 1

A. Achievability Proof

Fix $P_{X|S}(x|s)$ and $\epsilon_1 > \epsilon_2 > 0$ such that, $P_Z = Q_0$.

Codebook Generation: For every $S^n \in \mathcal{S}^n$ let $C_n \triangleq \{X^n(S^n, m)\}_{m \in \mathcal{M}}$, where $\mathcal{M} \in [1 : 2^{nR}]$, be a random codebook consisting of independent random sequences each generated according to $P_{X|S}^{\otimes n}(\cdot|s_i)$. We denote a realization of C_n by $\mathcal{C}_n \triangleq \{x^n(s^n, m)\}_{m \in \mathcal{M}}$.

Encoding: Given the channel state information s^n , to send message m the transmitter computes $x^n(s^n, m)$ and transmits it over the channel.

For a fixed codebook \mathcal{C}_n , the induced joint distribution is

$$P_{S^n, M, X^n, Z^n}^{(\mathcal{C}_n)}(s^n, m, \tilde{x}^n, z^n) = Q_S^n(s^n) 2^{-nR} \mathbb{1}_{\{\tilde{x}^n = x^n(s^n, m)\}} W_{Z|S, X}^{\otimes n}(z^n | s^n, \tilde{x}^n). \quad (63)$$

Covert Analysis: We now show $\mathbb{E}_{C_n} [\mathbb{D}(P_{Z^n|C_n} || Q_Z^{\otimes n})] \xrightarrow{n \rightarrow \infty} 0$, and then choose $P_{X|S}$ such that it satisfies $Q_Z = Q_0$. Henceforth, we denote by $P^{(\mathcal{C}_n)}$ the distributions induced by a fixed codebook \mathcal{C}_n , and by $P_{\cdot|C_n}$ the distributions induced by a random codebook \mathcal{C}_n . First, consider the following marginal from (63),

$$P_{Z^n|C_n}(z^n) = \sum_{s^n} \sum_m Q_S^n(s^n) 2^{-nR} W_{Z|S, X}^{\otimes n}(z^n | s^n, X^n(s^n, m)). \quad (64)$$

We now have,

$$\begin{aligned} \mathbb{E}_{C_n} [\mathbb{D}(P_{Z^n|C_n} || Q_Z^{\otimes n})] &= \mathbb{E}_{C_n} \left[\sum_{z^n} P_{Z^n|C_n}(z^n) \log \left(\frac{P_{Z^n|C_n}(z^n)}{Q_Z^{\otimes n}(z^n)} \right) \right] \\ &= \mathbb{E}_{C_n} \left[\sum_{z^n} \sum_{s^n} \sum_m \frac{1}{2^{nR}} Q_S^n(s^n) W_{Z|S, X}^{\otimes n}(z^n | s^n, X^n(s^n, m)) \log \left(\frac{\sum_{(\tilde{s}^n, \tilde{m})} Q_S^{\otimes n}(\tilde{s}^n) W_{Z|S, X}^{\otimes n}(z^n | \tilde{s}^n, X^n(\tilde{s}^n, \tilde{m}))}{2^{nR} Q_Z^{\otimes n}(z^n)} \right) \right] \\ &\stackrel{(a)}{\leq} \sum_{z^n} \sum_{s^n} \sum_m \frac{1}{2^{nR}} \sum_{x^n(s^n, m)} P_{S, X, Z}^{\otimes n}(s^n, x^n(s^n, m), z^n) \log \mathbb{E}_{\lambda_m} \left[\frac{\sum_{(\tilde{s}^n, \tilde{m})} Q_S^{\otimes n}(\tilde{s}^n) W_{Z|S, X}^{\otimes n}(z^n | \tilde{s}^n, X^n(\tilde{s}^n, \tilde{m}))}{2^{nR} Q_Z^{\otimes n}(z^n)} \right] \\ &= \sum_{z^n} \sum_{s^n} \sum_m \frac{1}{2^{nR}} \sum_{x^n(s^n, m)} P_{S, X, Z}^{\otimes n}(s^n, x^n(s^n, m), z^n) \\ &\quad \times \log \left(\frac{Q_S^{\otimes n}(s^n) W_{Z|S, X}^{\otimes n}(z^n | s^n, x^n(s^n, m))}{2^{nR} Q_Z^{\otimes n}(z^n)} + \mathbb{E}_{\lambda_m} \left[\frac{\sum_{(\tilde{s}^n, \tilde{m}) \neq (s^n, m)} Q_S^{\otimes n}(\tilde{s}^n) W_{Z|S, X}^{\otimes n}(z^n | \tilde{s}^n, X^n(\tilde{s}^n, \tilde{m}))}{2^{nR} Q_Z^{\otimes n}(z^n)} \right] \right) \\ &\stackrel{(b)}{\leq} \sum_{z^n} \sum_{s^n} \sum_m \frac{1}{2^{nR}} \sum_{x^n(s^n, m)} P_{S, X, Z}^{\otimes n}(s^n, x^n(s^n, m), z^n) \end{aligned}$$

$$\begin{aligned}
& \times \log \left(\frac{Q_S^{\otimes n}(s^n)W_{Z|S,X}^{\otimes n}(z^n|s^n, x^n(s^n, m))}{2^{nR}Q_Z^{\otimes n}(z^n)} + \frac{\sum_{(\tilde{s}^n, \tilde{m})} Q_S^{\otimes n}(s^n)W_{Z|S}^{\otimes n}(z^n|s^n)}{2^{nR}Q_Z^{\otimes n}(z^n)} \right) \\
& = \sum_{z^n} \sum_{s^n} \sum_m \frac{1}{2^{nR}} \sum_{x^n(s^n, m)} P_{S,X,Z}^{\otimes n}(s^n, x^n(s^n, m), z^n) \log \left(\frac{Q_S^{\otimes n}(s^n)W_{Z|S,X}^{\otimes n}(z^n|s^n, x^n(s^n, m))}{2^{nR}Q_Z^{\otimes n}(z^n)} + 1 \right) \\
& \triangleq \Psi_1 + \Psi_2, \tag{65}
\end{aligned}$$

where (a) follows from Jensen's inequality and (b) follows by adding some terms to the nominator of the second term in the argument of the log function. We define Ψ_1 and Ψ_2 as

$$\begin{aligned}
\Psi_1 & = \sum_m \frac{1}{2^{nR}} \sum_{(s^n, x^n(s^n, m), z^n) \in \mathcal{T}_\epsilon^{(n)}} P_{S,X,Z}^{\otimes n}(s^n, x^n(s^n, m), z^n) \log \left(\frac{Q_S^{\otimes n}(s^n)W_{Z|S,X}^{\otimes n}(z^n|s^n, x^n(s^n, m))}{2^{nR}Q_Z^{\otimes n}(z^n)} + 1 \right) \\
& \leq \log \left(\frac{2^{-n(1-\epsilon)(\mathbb{H}(S)+\mathbb{H}(Z|S,X))}}{2^{nR}2^{-n(1+\epsilon)\mathbb{H}(Z)}} + 1 \right) \tag{66}
\end{aligned}$$

$$\begin{aligned}
\Psi_2 & = \sum_m \frac{1}{2^{nR}} \sum_{(s^n, x^n(s^n, m), z^n) \notin \mathcal{T}_\epsilon^{(n)}} P_{S,X,Z}^{\otimes n}(s^n, x^n(s^n, m), z^n) \log \left(\frac{Q_S^{\otimes n}(s^n)W_{Z|S,X}^{\otimes n}(z^n|s^n, x^n(s^n, m))}{2^{nR}Q_Z^{\otimes n}(z^n)} + 1 \right) \\
& \leq 2|S||X||Z|e^{-n\epsilon^2\mu_{S,X,Z}} n \log \left(\frac{3}{\mu_Z} + 1 \right) \tag{67}
\end{aligned}$$

where $\mu_{S,X,Z} = \min_{(s,x,z) \in (S,\mathcal{X},Z)} P_{S,X,Z}(s,x,z)$ and $\mu_Z = \min_{z \in Z} P_Z(z)$. When $n \rightarrow \infty$ then $\Psi_2 \rightarrow 0$ when n grows if

$$R > \mathbb{I}(S, X; Z) - \mathbb{H}(S). \tag{68}$$

Basic information identities yield:

$$\mathbb{I}(X, S; Z) = \mathbb{I}(X; S, Z) + \mathbb{I}(S; Z) - \mathbb{I}(X; S). \tag{69}$$

Substituting (69) into (68) leads to

$$R > \mathbb{I}(X; Z|S) - \mathbb{H}(S|Z). \tag{70}$$

Decoding and Error Probability Analysis: By access to the channel state s^n , the receiver declares that $\hat{m} = m$ if there exists a unique index \hat{m} such that $(x^n(s^n, \hat{m}), y^n, s^n) \in \mathcal{T}_\epsilon^{(n)}(X, Y, S)$. According to the law of large numbers and the packing lemma the probability of error goes to zero as $n \rightarrow \infty$ if [31],

$$R < \mathbb{I}(X; Y|S). \tag{71}$$

The region in Theorem 1 is derived from (70) and (71).

B. Converse Proof

We now develop an upper bound for the non-causal side information. Consider any sequence of length- n codes for a state-dependent channel with channel state available non-causally at both the transmitter and the receiver such that $P_e^{(n)} \leq \epsilon_n$ and $\mathbb{D}(P_{Z^n} || Q_0^{\otimes n}) \leq \delta$ with $\lim_{n \rightarrow \infty} \epsilon_n = 0$. Note that the converse is consistent with the model and does *not* require δ to vanish.

1) *Epsilon Rate Region*: We first define a region \mathcal{S}_ϵ for $\epsilon > 0$ that expands the region defined in (6) as follows.

$$\mathcal{S}_\epsilon \triangleq \{R \geq 0 : \exists P_{S,X,Y,Z} \in \mathcal{D}_\epsilon : R \leq \mathbb{I}(X;Y|S) + \epsilon\} \quad (72a)$$

where

$$\mathcal{D}_\epsilon = \left\{ \begin{array}{l} P_{S,X,Y,Z} : \\ P_{S,X,Y,Z} = Q_S P_V P_{X|V} W_{Y,Z|X,S} \\ \mathbb{D}(P_Z \| Q_0) \leq \epsilon \\ \mathbb{H}(S|Z) > \mathbb{I}(X;Z|S) - \mathbb{I}(X;Y|S) - 3\epsilon \end{array} \right\}, \quad (72b)$$

where $\epsilon \triangleq \max\{\epsilon_n, \nu \geq \frac{\delta}{n}\}$. We next show that if a rate R is achievable then $R \in \mathcal{S}_\epsilon$ for any $\epsilon > 0$.

For any $\epsilon_n > 0$, we start by upper bounding nR using standard techniques.

$$\begin{aligned} nR &= \mathbb{H}(M) \\ &\stackrel{(a)}{\leq} \mathbb{H}(M|S^n) - \mathbb{H}(M|Y^n, S^n) + n\epsilon_n \\ &= \mathbb{I}(M; Y^n | S^n) + n\epsilon_n \\ &= \sum_{i=1}^n \mathbb{I}(M; Y_i | Y^{i-1}, S^n) + n\epsilon_n \\ &= \sum_{i=1}^n [\mathbb{H}(Y_i | Y^{i-1}, S^n) - \mathbb{H}(Y_i | M, Y^{i-1}, S^n)] + n\epsilon_n \\ &\stackrel{(b)}{\leq} \sum_{i=1}^n [\mathbb{H}(Y_i | S_i) - \mathbb{H}(Y_i | M, Y^{i-1}, S^n, X^n)] + n\epsilon_n \\ &= \sum_{i=1}^n [\mathbb{H}(Y_i | S_i) - \mathbb{H}(Y_i | S_i, X_i)] + n\epsilon_n \\ &= \sum_{i=1}^n \mathbb{I}(X_i; Y_i | S_i) + n\epsilon_n \\ &\stackrel{(c)}{\leq} n\mathbb{I}(\tilde{X}; \tilde{Y} | \tilde{S}) + n\epsilon_n \end{aligned} \quad (73)$$

$$\stackrel{(d)}{\leq} n\mathbb{I}(\tilde{X}; \tilde{Y} | \tilde{S}) + n\epsilon \quad (74)$$

where

- (a) follows from Fano's inequality and independence of M from S^n ;
- (b) holds because conditioning does not increase entropy;
- (c) follows from the concavity of mutual information, with the resulting random variables \tilde{X} , \tilde{S} , \tilde{Y} , and \tilde{Z} to having the following distributions

$$\tilde{P}_{X,S}(x, s) \triangleq \frac{1}{n} \sum_{i=1}^n P_{X_i, S_i}(x, s), \quad (75a)$$

$$\tilde{P}_{X,S,Y,Z}(x, s, y, z) \triangleq \tilde{P}_{X,S}(x, s) W_{Y,Z|X,S}(y, z | x, s); \quad (75b)$$

- (d) follows by defining $\epsilon \triangleq \max\{\epsilon_n, \nu \geq \frac{\delta}{n}\}$.

We also have,

$$\begin{aligned}
nR &\geq \mathbb{H}(M) \\
&= \mathbb{H}(M|S^n) \\
&\geq \mathbb{I}(M; Z^n|S^n) \\
&\stackrel{(a)}{=} \mathbb{I}(M, X^n; Z^n|S^n) \\
&\geq \mathbb{I}(X^n; Z^n|S^n) \\
&= \mathbb{I}(X^n, S^n; Z^n) - \mathbb{I}(S^n; Z^n) \\
&= \sum_{x^n} \sum_{s^n} \sum_{z^n} P(x^n, s^n, z^n) \log \frac{W_{Z|X,S}^{\otimes n}(z^n|x^n, s^n)}{P(z^n)} - \mathbb{H}(S^n) + \mathbb{H}(S^n|Z^n) \\
&\geq \sum_{x^n} \sum_{s^n} \sum_{z^n} P(x^n, s^n, z^n) \log \frac{W_{Z|X,S}^{\otimes n}(z^n|x^n, s^n)}{P(z^n)} + \mathbb{D}(P_{Z^n}||Q_0^{\otimes n}) - \mathbb{H}(S^n) - \delta \\
&\geq \sum_{i=1}^n \sum_{x_i} \sum_{s_i} \sum_{z_i} P(x_i, s_i, z_i) \log \frac{W_{Z|X,S}(z_i|x_i, s_i)}{Q_0(z_i)} - \sum_{i=1}^n \mathbb{H}(S_i) - \delta \\
&= \sum_{i=1}^n \mathbb{D}(P_{X_i, S_i, Z_i}||P_{X_i, S_i} Q_0) - \sum_{i=1}^n \mathbb{H}(S_i) - \delta \\
&\stackrel{(b)}{\geq} n\mathbb{D}(\tilde{P}_{X,S,Z}||\tilde{P}_{X,S} Q_0) - n\mathbb{H}(\tilde{S}) - \delta \\
&= n\mathbb{D}(\tilde{P}_{X,S,Z}||\tilde{P}_{X,S}\tilde{P}_Z) + \mathbb{D}(\tilde{P}_Z||Q_0) - n\mathbb{H}(\tilde{S}) - \delta \\
&\stackrel{(c)}{\geq} n\mathbb{I}(\tilde{X}, \tilde{S}; \tilde{Z}) - n\mathbb{H}(\tilde{S}) - 2\delta
\end{aligned} \tag{76}$$

where

- (a) follows because X^n is a function of (M, S^n) ;
- (b) follows from Jensen's inequality, the convexity of $\mathbb{D}(\cdot||\cdot)$, and concavity of $\mathbb{H}(\cdot)$;
- (c) follows from the definition of random variables \tilde{X} , \tilde{S} , \tilde{Y} , and \tilde{Z} in (75).

For any $\nu > 0$, choosing n large enough substituting (69) into (76) ensures that

$$\begin{aligned}
nR &\geq \mathbb{I}(\tilde{X}; \tilde{Z}|\tilde{S}) - \mathbb{H}(\tilde{S}|\tilde{Z}) - 2\nu, \\
&\geq \mathbb{I}(\tilde{X}; \tilde{Z}|\tilde{S}) - \mathbb{H}(\tilde{S}|\tilde{Z}) - 2\epsilon,
\end{aligned} \tag{77}$$

where the last equality follows from the definition of $\epsilon \triangleq \max\{\epsilon_n, \nu\}$. To show that $\mathbb{D}(P_Z||Q_0) \leq \epsilon$, note that for n large enough

$$\mathbb{D}(P_Z||Q_0) = \mathbb{D}(P_{\tilde{Z}}||Q_0) = \mathbb{D}\left(\frac{1}{n} \sum_{i=1}^n P_{Z_i} \middle| \middle| Q_0\right) \leq \frac{1}{n} \sum_{i=1}^n \mathbb{D}(P_{Z_i}||Q_0) \leq \frac{1}{n} \mathbb{D}(P_{Z^n}||Q_0^{\otimes n}) \leq \frac{\delta}{n} \leq \nu \leq \epsilon. \tag{78}$$

Combining (74) and (77) shows that $\forall \epsilon_n, \nu > 0$, $R \leq \max\{x : x \in \mathcal{S}_\epsilon\}$. Therefore,

$$C_{\text{NC-TR}} = \max \left\{ x : x \in \bigcap_{\epsilon > 0} \mathcal{S}_\epsilon \right\}. \tag{79}$$

2) *Continuity at Zero*: One can prove the continuity at zero of \mathcal{S}_ϵ by substituting $\min\{\mathbb{I}(U; Y) - \mathbb{I}(U; S), \mathbb{I}(U, V; Y) - \mathbb{I}(U; S|V)\}$ with $\mathbb{I}(X; Y|S)$ and $\mathbb{I}(V; Z) - \mathbb{I}(V; S)$ with $\mathbb{I}(X; Z|S) - \mathbb{H}(S|Z)$ in Appendix I and following the exact same arguments.

APPENDIX B
PROOF OF THEOREM 2

A. *Achievability Proof*

To prove the achievability of Theorem 2 it is convenient to introduce an associated channel $W_{Y,Z|U,S}$ as follows: Let $U \in \mathcal{U}$ be an arbitrary auxiliary random variable which is independent of the state S , and let $x : U \times S \rightarrow X$ be a deterministic mapping subject to $\mathbb{1}_{\{x=x(s,u)\}}$. According to the Shannon strategy [32], we define the $W_{Y,Z|U,S}$ as a channel specified by

$$W_{Y,Z|U,S} = \sum_{x \in \mathcal{X}} \mathbb{1}_{\{x=x(s,u)\}} W_{Y,Z|X,S}(y, z|x, s), \quad (80)$$

which results in a channel with input U , outputs Y, Z , and state S . Therefore, we only focus on the coding problem for the channel $W_{Y,Z|U,S}$ for the achievability proof.

We use block-Markov coding in which B independent messages are transmitted over B channel blocks, each of length r , therefore the overall codeword length is $n = rB$ symbols. The warden's observation Z^n can be described in terms of observations in individual block-Markov blocks $Z^n = (Z_1^r, \dots, Z_B^r)$. The distribution of the warden's observation, induced by the block-Markov coding, is $P_{Z^n} \triangleq P_{Z_1^r, \dots, Z_B^r}$ and the target output distribution is $Q_Z^{\otimes n} = \prod_{j=1}^B Q_Z^{\otimes r}$.

$$\begin{aligned} \mathbb{D}(P_{Z^n} || Q_Z^{\otimes n}) &= \mathbb{D}(P_{Z_1^r \dots Z_B^r} || Q_Z^{\otimes rB}) \\ &= \sum_{j=1}^B \mathbb{D}(P_{Z_j^r | Z_{j+1}^{B,r}} || Q_Z^{\otimes r} | P_{Z_{j+1}^{B,r}}) \\ &= \sum_{j=1}^B [\mathbb{D}(P_{Z_j^r} || Q_Z^{\otimes r}) + \mathbb{D}(P_{Z_j^r | Z_{j+1}^{B,r}} || P_{Z_j^r} | P_{Z_{j+1}^{B,r}})] \\ &= \sum_{j=1}^B [\mathbb{D}(P_{Z_j^r} || Q_Z^{\otimes r}) + \mathbb{I}(Z_j^r; Z_{j+1}^{B,r})], \end{aligned} \quad (81)$$

where $Z_{j+1}^{B,r} = \{Z_{j+1}^r, \dots, Z_B^r\}$. Hence, $\mathbb{D}(P_{Z^n} || Q_Z^{\otimes n}) \xrightarrow{n \rightarrow \infty} 0$, is equivalent to;

$$\mathbb{D}(P_{Z_j^r} || Q_Z^{\otimes r}) \xrightarrow{r \rightarrow \infty} 0, \quad \mathbb{I}(Z_j^r; Z_{j+1}^{B,r}) \xrightarrow{r \rightarrow \infty} 0, \quad \forall j \in \llbracket 1 : B \rrbracket. \quad (82)$$

This requires constructing a code that approximates $Q_Z^{\otimes r}$ in each block, while eliminating the dependencies across blocks created by block-Markov coding. The random code generation is as follows:

Fix $P_U(u)$ and $\epsilon_1 > \epsilon_2 > 0$ such that, $P_Z = Q_0$.

Codebook Generation for Keys: For each block $j \in \llbracket 1 : B \rrbracket$, create a function $\Phi : S_j^r \rightarrow \llbracket 1 : 2^{rR_K} \rrbracket$ through random binning by choosing the value of $\Phi(s_j^r)$ independently and uniformly at random for every $s_j^r \in S^r$. The key $k_j = \Phi(s_j^r)$ obtained in block $j \in \llbracket 1 : B \rrbracket$ from the state sequence s_j^r is used to assist the encoder in the next block.

Codebook Generation for Messages: For each block $j \in \llbracket 1 : B \rrbracket$, let $C_r \triangleq \{U^r(m_j, k_{j-1})\}_{(m_j, k_{j-1}) \in \mathcal{M} \times \mathcal{K}}$, where $\mathcal{M} \in \llbracket 1 : 2^{rR} \rrbracket$ and $\mathcal{K} \in \llbracket 1 : 2^{rR_k} \rrbracket$, be a random codebook consisting of independent random sequences each generated according to $P_U^{\otimes r}$. We denote a realization of C_r by $\mathcal{C}_r \triangleq \{u^r(m_j, k_{j-1})\}_{(m_j, k_{j-1}) \in \mathcal{M} \times \mathcal{K}}$.

Encoding: For the first block, we assume that the transmitter and the receiver have access to a shared secret key k_0 , in this block to transmit m_1 the encoder computes $u^r(m_1, k_0)$ and transmits codeword x^r , where $x_i = x(u_i(m_1, k_0), s_i)$. At the end of the first block the encoder generates a key from CSI s_1^r to be used in Block 2.

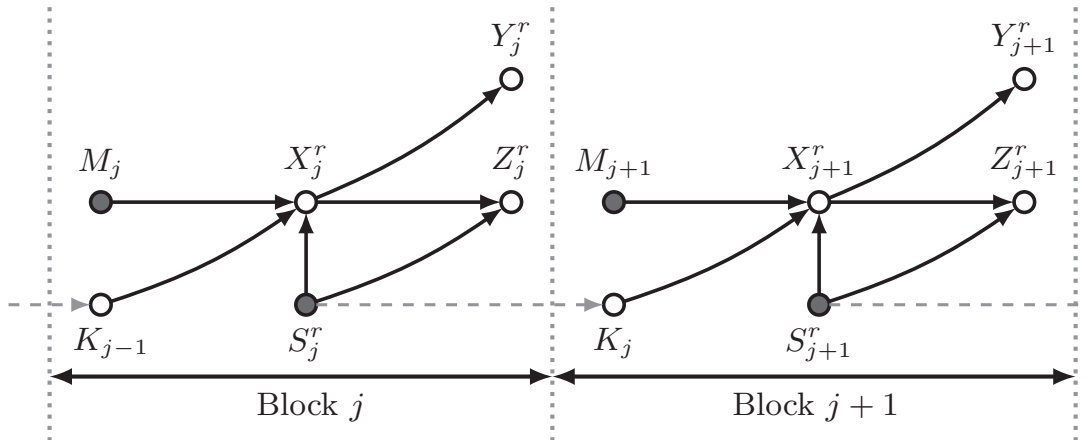

Fig. 8. Functional dependence graph for the block-Markov encoding scheme

For block $j \in \llbracket 2 : B \rrbracket$, to send message m_j according to the generated key k_{j-1} from the previous block, the encoder computes $u^r(m_j, k_{j-1})$ and transmits codeword x^r , where $x_i = x(u_i(m_j, k_{j-1}), s_i)$. Also, at the end of each block $j \in \llbracket 2 : B \rrbracket$ the encoder generates a key from CSI s_j^r to be used in next block.

Define

$$\begin{aligned} \Upsilon_{M_j, K_{j-1}, U^r, S_j^r, Z_j^r, K_j}^{(C_r)}(m_j, k_{j-1}, \tilde{u}^r, s_j^r, z_j^r, k_j) &\triangleq 2^{-r(R_k + R)} \mathbb{1}_{\{\tilde{u}^r = u^r(m_j, k_{j-1})\}} Q_S^{\otimes r}(s_j^r) \\ &\times W_{Z|U, S}^{\otimes r}(z_j^r | \tilde{u}^r, s_j^r) \mathbb{1}_{\{k_j = \Phi(s_j^r)\}}. \end{aligned} \quad (83)$$

For a fixed codebook \mathcal{C}_r , the induced joint distribution over the codebook (i.e. $P^{(C_r)}$) satisfies

$$\mathbb{D}\left(P_{M_j, K_{j-1}, U^r, S_j^r, Z_j^r, K_j}^{(C_r)} \parallel \Upsilon_{M_j, K_{j-1}, U^r, S_j^r, Z_j^r, K_j}^{(C_r)}\right) \leq \epsilon. \quad (84)$$

This intermediate distribution $\Upsilon^{(C_r)}$ approximates the true distribution $P^{(C_r)}$ and will be used in the sequel for bounding purposes. Expression (84) holds because the main difference in $\Upsilon^{(C_r)}$ is assuming the key K_{j-1} is uniformly distributed, which is made (arbitrarily) nearly uniform in $P^{(C_r)}$ with appropriate control of rate.

Covert Analysis: We now show $\mathbb{E}_{C_n}[\mathbb{D}(P_{Z^n|C_n} \parallel Q_Z^{\otimes n})] \xrightarrow{n \rightarrow \infty} 0$, where C_n is the set of all codebooks from all blocks, and then choose P_U and $x(u, s)$ such that it satisfies $Q_Z = Q_0$. From the expansion in (81), for every block $j \in \llbracket 2 : B \rrbracket$,

$$\begin{aligned} \mathbb{I}(Z_j^r; Z_{j+1}^{B,r}) &\leq \mathbb{I}(Z_j^r; K_j, Z_{j+1}^{B,r}) \\ &\stackrel{(a)}{=} \mathbb{I}(Z_j^r; K_j), \end{aligned} \quad (85)$$

where (a) holds because $Z_j^r - K_j - Z_{j+1}^{B,r}$ forms a Markov chain, as seen in the functional dependence graph depicted in Fig. 8. Also,

$$\begin{aligned} \mathbb{I}(Z_j^r; K_j) &= \mathbb{D}(P_{Z_j^r, K_j}^{(C_n)} \parallel P_{Z_j^r}^{(C_n)} P_{K_j}^{(C_n)}) \\ &\stackrel{(b)}{\leq} \mathbb{D}(P_{Z_j^r, K_j}^{(C_n)} \parallel Q_Z^{\otimes r} Q_{K_j}), \end{aligned} \quad (86)$$

where Q_{K_j} is the uniform distribution on $\llbracket 1 : 2^{rR_k} \rrbracket$ and (b) follows from the positivity of relative entropy and

$$\mathbb{D}(P_{Z_j^r, K_j} \parallel P_{Z_j^r} P_{K_j}) = \mathbb{D}(P_{Z_j^r, K_j} \parallel Q_Z^{\otimes r} Q_{K_j}) - \mathbb{D}(P_{K_j} \parallel Q_{K_j}) - \mathbb{D}(P_{Z_j^r} \parallel Q_Z^{\otimes r}). \quad (87)$$

Therefore by combining (81), (86), and (87)

$$\mathbb{D}(P_{Z^n|C_n} \| Q_Z^{\otimes n}) \leq 2 \sum_{j=1}^B \mathbb{D}(P_{Z_j^r, K_j|C_r} \| Q_Z^{\otimes r} Q_{K_j}). \quad (88)$$

We now proceed to bound the right hand side of (88). First, consider the marginal

$$\Upsilon_{Z_j^r, K_j|C_r}(z_j^r, k_j) = \sum_{m_j} \sum_{k_{j-1}} \sum_{s_j^r} \frac{1}{2^{r(R+R_k)}} Q_S^{\otimes r}(s_j^r) W_{Z|U,S}^{\otimes r}(z_j^r | U^r(m_j, k_{j-1}), s_j^r) \mathbb{1}_{\{k_j = \Phi(s_j^r)\}}. \quad (89)$$

From (84) and the monotonicity of KL-divergence we have,

$$\mathbb{D}(\Upsilon_{Z_j^r, K_j|C_r} \| P_{Z_j^r, K_j|C_r}) \leq \epsilon. \quad (90)$$

To bound the Right Hand Side (RHS) of (88) by using Lemma 1 and the triangle inequality we have

$$\mathbb{E}_{C_r} \| P_{Z_j^r, K_j|C_r} - Q_Z^{\otimes r} Q_{K_j} \|_1 \leq \mathbb{E}_{C_r} \| P_{Z_j^r, K_j|C_r} - \Upsilon_{Z_j^r, K_j|C_r} \|_1 + \mathbb{E}_{C_r} \| \Upsilon_{Z_j^r, K_j|C_r} - Q_Z^{\otimes r} Q_{K_j} \|_1. \quad (91)$$

From Lemma 1 and (90) the first term on the RHS of (91) vanishes as r grows; to bound the second term by using Lemma 1 we have,

$$\begin{aligned} & \mathbb{E}_{C_r} [\mathbb{D}(\Upsilon_{Z_j^r, K_j|C_r} \| Q_Z^{\otimes r} Q_{K_j})] = \mathbb{E}_{C_r} \left[\sum_{z_j^r, k_j} \Upsilon_{Z_j^r, K_j|C_r}(z_j^r, k_j) \log \left(\frac{\Upsilon_{Z_j^r, K_j|C_r}(z_j^r, k_j)}{Q_Z^{\otimes r}(z_j^r) Q_{K_j}(k_j)} \right) \right] \\ &= \mathbb{E}_{C_r} \left[\sum_{(z_j^r, k_j)} \sum_{m_j} \sum_{k_{j-1}} \frac{1}{2^{r(R+R_k)}} \sum_{s_j^r} Q_S^{\otimes r}(s_j^r) W_{Z|U,S}^{\otimes r}(z_j^r | U^r(m_j, k_{j-1}), s_j^r) \mathbb{1}_{\{k_j = \Phi(s_j^r)\}} \right. \\ & \quad \times \log \left(\frac{\sum_{\tilde{m}_j} \sum_{\tilde{k}_{j-1}} \sum_{\tilde{s}_j^r} Q_S^{\otimes r}(\tilde{s}_j^r) W_{Z|U,S}^{\otimes r}(z_j^r | U^r(\tilde{m}_j, \tilde{k}_{j-1}), \tilde{s}_j^r) \mathbb{1}_{\{k_j = \Phi(\tilde{s}_j^r)\}}}{2^{r(R+R_k - R_K)} Q_Z^{\otimes r}(z_j^r)} \right) \left. \right] \\ & \stackrel{(a)}{\leq} \sum_{(z_j^r, k_j)} \sum_{m_j} \sum_{k_{j-1}} \frac{1}{2^{r(R+R_k)}} \sum_{s_j^r} \sum_{u^r(m_j, k_{j-1})} \Upsilon_{U^r, S^r, Z^r}^{(C_r)}(u^r(m_j, k_{j-1}), s_j^r, z_j^r) \mathbb{E}_{\Phi(s_j^r)} [\mathbb{1}_{\{k_j = \Phi(s_j^r)\}}] \\ & \quad \times \log \mathbb{E}_{\setminus((m_j, k_{j-1}), \Phi(s_j^r))} \left[\frac{\sum_{\tilde{m}_j} \sum_{\tilde{k}_{j-1}} \sum_{\tilde{s}_j^r} Q_S^{\otimes r}(\tilde{s}_j^r) W_{Z|U,S}^{\otimes r}(z_j^r | U^r(\tilde{m}_j, \tilde{k}_{j-1}), \tilde{s}_j^r) \mathbb{1}_{\{k_j = \Phi(\tilde{s}_j^r)\}}}{2^{r(R+R_k - R_K)} Q_Z^{\otimes r}(z_j^r)} \right] \\ & \stackrel{(b)}{\leq} \sum_{(z_j^r, k_j)} \sum_{m_j} \sum_{k_{j-1}} \frac{1}{2^{r(R+R_k)}} \sum_{s_j^r} \sum_{u^r(m_j, k_{j-1})} \Upsilon_{U^r, S^r, Z^r}^{(C_r)}(u^r(m_j, k_{j-1}), s_j^r, z_j^r) \frac{1}{2^{rR_K}} \\ & \quad \times \log \frac{1}{2^{r(R+R_k - R_K)} Q_Z^{\otimes r}(z_j^r)} \left(Q_S^{\otimes r}(s_j^r) W_{Z|U,S}^{\otimes r}(z_j^r | u^r(m_j, k_{j-1}), s_j^r) \right. \\ & \quad + \mathbb{E}_{\setminus(m_j, k_{j-1})} \left[\sum_{(\tilde{m}_j, \tilde{k}_{j-1}) \neq (m_j, k_{j-1})} Q_S^{\otimes r}(\tilde{s}_j^r) W_{Z|U,S}^{\otimes r}(z_j^r | U^r(\tilde{m}_j, \tilde{k}_{j-1}), \tilde{s}_j^r) \right] \\ & \quad + \mathbb{E}_{\setminus\Phi(s_j^r)} \left[\sum_{\tilde{s}_j^r} Q_S^{\otimes r}(\tilde{s}_j^r) W_{Z|U,S}^{\otimes r}(z_j^r | u^r(m_j, k_{j-1}), \tilde{s}_j^r) \mathbb{1}_{\{k_j = \Phi(\tilde{s}_j^r)\}} \right] \\ & \quad \left. + \mathbb{E}_{\setminus((m_j, k_{j-1}), \Phi(s_j^r))} \left[\sum_{\tilde{s}_j^r} \sum_{(\tilde{m}_j, \tilde{k}_{j-1}) \neq (m_j, k_{j-1})} Q_S^{\otimes r}(\tilde{s}_j^r) W_{Z|U,S}^{\otimes r}(z_j^r | U^r(\tilde{m}_j, \tilde{k}_{j-1}), \tilde{s}_j^r) \mathbb{1}_{\{k_j = \Phi(\tilde{s}_j^r)\}} \right] \right) \\ & \leq \sum_{(z_j^r, k_j)} \sum_{m_j} \sum_{k_{j-1}} \frac{1}{2^{r(R+R_k + R_K)}} \sum_{s_j^r} \sum_{u^r(m_j, k_{j-1})} \Upsilon_{U^r, S^r, Z^r}^{(C_r)}(u^r(m_j, k_{j-1}), s_j^r, z_j^r) \end{aligned}$$

$$\begin{aligned}
& \times \log \left(\frac{Q_S^{\otimes r}(s_j^r) W_{Z|U,S}^{\otimes r}(z_j^r | u^r(m_j, k_{j-1}), s_j^r)}{2^{r(R+R_k-R_K)} Q_Z^{\otimes r}(z_j^r)} + \sum_{(\tilde{k}_{j-1}, \tilde{m}_j) \neq (m_j, k_{j-1})} \frac{Q_{S,Z}^{\otimes r}(s_j^r, z_j^r)}{2^{r(R+R_k-R_K)} Q_Z^{\otimes r}(z_j^r)} \right. \\
& \left. + \frac{W_{Z|U}^{\otimes r}(z_j^r | u^r(m_j, k_{j-1}))}{2^{r(R+R_k)} Q_Z^{\otimes r}(z_j^r)} + 1 \right) \\
& \leq \sum_{(z_j^r, k_j)} \sum_{m_j} \sum_{k_{j-1}} \frac{1}{2^{r(R+R_k+R_K)}} \sum_{s_j^r} \sum_{u^r(m_j, k_{j-1})} \Upsilon_{U^r, S^r, Z^r}^{(C_r)}(u^r(m_j, k_{j-1}), s_j^r, z_j^r) \\
& \quad \times \log \left(\frac{Q_S^{\otimes r}(s_j^r) W_{Z|U,S}^{\otimes r}(z_j^r | u^r(m_j, k_{j-1}), s_j^r)}{2^{r(R+R_k-R_K)} Q_Z^{\otimes r}(z_j^r)} + \frac{2^{rR_K} Q_{S,Z}^{\otimes r}(s_j^r, z_j^r)}{Q_Z^{\otimes r}(z_j^r)} + \frac{W_{Z|U}^{\otimes r}(z_j^r | u^r(m_j, k_{j-1}))}{2^{r(R+R_k)} Q_Z^{\otimes r}(z_j^r)} + 1 \right) \\
& \triangleq \Psi_1 + \Psi_2, \tag{92}
\end{aligned}$$

where (a) follows from Jensen's inequality and (b) holds because $\mathbf{1}_{\{\cdot\}} \leq 1$. We defined Ψ_1 and Ψ_2 as

$$\begin{aligned}
\Psi_1 &= \sum_{k_j} \sum_{m_j} \sum_{k_{j-1}} \frac{1}{2^{r(R+R_k+R_K)}} \sum_{(u^r(m_j, k_{j-1}), s_j^r, z_j^r) \in \mathcal{T}_\epsilon^{(n)}} \Upsilon_{U^r, S^r, Z^r}^{(C_r)}(u^r(m_j, k_{j-1}), s_j^r, z_j^r) \\
& \quad \times \log \left(\frac{Q_S^{\otimes r}(s_j^r) W_{Z|U,S}^{\otimes r}(z_j^r | u^r(m_j, k_{j-1}), s_j^r)}{2^{r(R+R_k-R_K)} Q_Z^{\otimes r}(z_j^r)} + \frac{2^{rR_K} Q_{S,Z}^{\otimes r}(s_j^r, z_j^r)}{Q_Z^{\otimes r}(z_j^r)} + \frac{W_{Z|U}^{\otimes r}(z_j^r | u^r(m_j, k_{j-1}))}{2^{r(R+R_k)} Q_Z^{\otimes r}(z_j^r)} + 1 \right) \\
& \leq \log \left(\frac{2^{rR_K} 2^{-r(1-\epsilon)(\mathbb{H}(S)+\mathbb{H}(Z|U,S))}}{2^{r(R+R_k)} 2^{-r(1+\epsilon)\mathbb{H}(Z)}} + \frac{2^{rR_K} 2^{-r(1-\epsilon)\mathbb{H}(S,Z)}}{2^{-r(1+\epsilon)\mathbb{H}(Z)}} + \frac{2^{-r(1-\epsilon)\mathbb{H}(Z|U)}}{2^{r(R+R_k)} 2^{-r(1+\epsilon)\mathbb{H}(Z)}} + 1 \right) \tag{93}
\end{aligned}$$

$$\begin{aligned}
\Psi_2 &= \sum_{k_j} \sum_{m_j} \sum_{k_{j-1}} \frac{1}{2^{r(R+R_k+R_K)}} \sum_{(u^r(m_j, k_{j-1}), s_j^r, z_j^r) \notin \mathcal{T}_\epsilon^{(n)}} \Upsilon_{U^r, S^r, Z^r}^{(C_r)}(u^r(m_j, k_{j-1}), s_j^r, z_j^r) \\
& \quad \times \log \left(\frac{Q_S^{\otimes r}(s_j^r) W_{Z|U,S}^{\otimes r}(z_j^r | u^r(m_j, k_{j-1}), s_j^r)}{2^{r(R+R_k-R_K)} Q_Z^{\otimes r}(z_j^r)} + \frac{2^{rR_K} Q_{S,Z}^{\otimes r}(s_j^r, z_j^r)}{Q_Z^{\otimes r}(z_j^r)} + \frac{W_{Z|U}^{\otimes r}(z_j^r | u^r(m_j, k_{j-1}))}{2^{r(R+R_k)} Q_Z^{\otimes r}(z_j^r)} + 1 \right) \\
& \leq 2|U||S||Z| e^{-r\epsilon^2 \mu_{U,S,Z}} \log \left(\frac{3}{\mu_Z} + 1 \right), \tag{94}
\end{aligned}$$

where $\mu_{U,S,Z} = \min_{(u,s,z) \in (U,S,Z)} P_{U,S,Z}(u,s,z)$ and $\mu_Z = \min_{z \in Z} P_Z(z)$. When $r \rightarrow \infty$ then $\Psi_2 \rightarrow 0$, by choosing $R_K = \mathbb{H}(S|Z) - \epsilon$, Ψ_1 vanishes when r grows if,

$$R + R_k > \mathbb{I}(U; Z|S), \tag{95a}$$

$$R + R_k > \mathbb{I}(U; Z). \tag{95b}$$

Here since U and S are independent (95b) is redundant because of (95a).

Decoding and Error Probability Analysis: At the end of block $j \in \llbracket 1 : B \rrbracket$, using its knowledge of the channel state s_j^r of the current block and the key k_{j-1} generated from the previous block, the receiver finds a unique \hat{m}_j such that $(u^r(\hat{m}_j, k_{j-1}), s_j^r, y_j^r) \in \mathcal{T}_\epsilon^{(r)}$. To analyze the probability of error we define the following error events for $j \in \llbracket 1 : B \rrbracket$

$$\mathcal{E} = \{\hat{M} \neq M\}, \tag{96a}$$

$$\mathcal{E}_j = \{\hat{M}_j \neq M_j\}, \tag{96b}$$

$$\mathcal{E}_{1,j} = \{(U^r(M_j, K_{j-1}), S_j^r) \notin \mathcal{T}_{\epsilon_1}^{(r)}(Q_S P_U)\}, \tag{96c}$$

$$\mathcal{E}_{2,j} = \{(U^r(M_j, K_{j-1}), S_j^r, Y_j^r) \notin \mathcal{T}_{\epsilon_2}^{(r)}(Q_S P_U W_{Y|U,S})\}, \tag{96d}$$

$$\mathcal{E}_{3,j} = \{(U^r(k_{j-1}, \hat{m}_j), S_j^r, Y_j^r) \in \mathcal{T}_{\epsilon_2}^{(r)}, \text{ for some } \hat{m}_j \neq M_j\}, \tag{96e}$$

where $\epsilon_2 > \epsilon_1 > \epsilon > 0$. The probability of error is upper bounded as follows,

$$\mathbb{P}(\mathcal{E}) \leq \mathbb{P}\left\{\bigcup_{j=1}^B \mathcal{E}_j\right\} \leq \sum_{j=1}^B \mathbb{P}(\mathcal{E}_j). \quad (97)$$

Now we bound $\mathbb{P}(\mathcal{E}_j)$ by using union bound

$$\mathbb{P}(\mathcal{E}_j) \leq \mathbb{P}(\mathcal{E}_{1,j}) + \mathbb{P}(\mathcal{E}_{1,j}^c \cap \mathcal{E}_{2,j}) + \mathbb{P}(\mathcal{E}_{2,j}^c \cap \mathcal{E}_{3,j}). \quad (98)$$

By the law of large numbers the first and second term on RHS of (98) vanishes when r grows. According to the law of large numbers and the packing lemma, the last term on RHS of (98) vanishes when r grows if [31],

$$R < \mathbb{I}(U; S, Y) = \mathbb{I}(U; Y|S). \quad (99)$$

Furthermore, this scheme requires that

$$R_k \leq R_K = \mathbb{H}(S|Z) - \epsilon, \quad (100)$$

The region in Theorem 2 is obtained by applying Fourier-Motzkin to (95a), (99), and (100).

B. Converse Proof

We now develop an upper bound when CSI is available causally at both of the legitimate terminals. Consider any sequence of length- n codes for a state-dependent channel with channel state available causally at both the transmitter and the receiver such that $P_e^{(n)} \leq \epsilon_n$ and $\mathbb{D}(P_{Z^n} \| Q_0^{\otimes n}) \leq \delta$ with $\lim_{n \rightarrow \infty} \epsilon_n = 0$. Note that the converse is consistent with the model and does *not* require δ to vanish.

1) *Epsilon Rate Region:* We first define a region \mathcal{S}_ϵ for $\epsilon > 0$ that expands the region defined in (8) as follows.

$$\mathcal{S}_\epsilon \triangleq \{R \geq 0 : \exists P_{S,U,X,Y,Z} \in \mathcal{D}_\epsilon : R \leq \mathbb{I}(U; Y|S) + \epsilon\} \quad (101a)$$

where

$$\mathcal{D}_\epsilon = \left\{ \begin{array}{l} P_{S,U,X,Y,Z} : \\ P_{S,U,X,Y,Z} = Q_S P_U \mathbb{1}_{\{X=X(U,S)\}} W_{Y,Z|X,S} \\ \mathbb{D}(P_Z \| Q_0) \leq \epsilon \\ \mathbb{H}(S|Z) > \mathbb{I}(U; Z|S) - \mathbb{I}(U; Y|S) - 3\epsilon \\ |\mathcal{U}| \leq |\mathcal{X}| + 1 \end{array} \right\}, \quad (101b)$$

where $\epsilon \triangleq \max\{\epsilon_n, \nu \geq \frac{\delta}{n}\}$. We next show that if a rate R is achievable then $R \in \mathcal{S}_\epsilon$ for any $\epsilon > 0$.

For any $\epsilon_n > 0$, we start by upper bounding nR using standard techniques.

$$\begin{aligned} nR &= \mathbb{H}(M) \\ &\stackrel{(a)}{\leq} \mathbb{H}(M|S^n) - \mathbb{H}(M|Y^n, S^n) + n\epsilon_n \\ &= \mathbb{I}(M; Y^n|S^n) + n\epsilon_n \\ &= \sum_{i=1}^n \mathbb{I}(M; Y_i|Y^{i-1}, S^n) + n\epsilon_n \\ &= \sum_{i=1}^n [\mathbb{H}(Y_i|Y^{i-1}, S^n) - \mathbb{H}(Y_i|M, Y^{i-1}, S^n)] + n\epsilon_n \end{aligned}$$

$$\begin{aligned}
&\stackrel{(b)}{\leq} \sum_{i=1}^n [\mathbb{H}(Y_i|S_i) - \mathbb{H}(Y_i|U_i, S_i)] + n\epsilon_n \\
&= \sum_{i=1}^n \mathbb{I}(U_i; Y_i|S_i) + n\epsilon_n \\
&\stackrel{(c)}{\leq} n\mathbb{I}(\tilde{U}; \tilde{Y}|\tilde{S}) + n\epsilon_n \\
&\stackrel{(d)}{\leq} n\mathbb{I}(\tilde{U}; \tilde{Y}|\tilde{S}) + n\epsilon
\end{aligned} \tag{102}$$

where

- (a) follows from Fano's inequality and independence of M from S^n ;
- (b) holds because conditioning does not increase entropy and $U_i = (M, Y^{i-1}, S_{\sim i}^n)$;
- (c) follows from the concavity of mutual information, with the resulting random variables \tilde{U} , \tilde{S} , and \tilde{Y} having the following distributions

$$\tilde{P}_{U,S,X}(u, s, x) \triangleq \frac{1}{n} \sum_{i=1}^n P_{U_i, S_i, X_i}(u, s, x), \tag{103a}$$

$$\tilde{P}_{U,S,X,Y,Z}(u, s, x, y, z) \triangleq \tilde{P}_{U,S,X}(u, s, x) W_{Y,Z|X,S}(y, z|x, s), \tag{103b}$$

- (d) follows by defining $\epsilon \triangleq \max\{\epsilon_n, \nu \geq \frac{\delta}{n}\}$.

We now have,

$$\begin{aligned}
nR &\stackrel{(a)}{\geq} n\mathbb{I}(\tilde{X}, \tilde{S}; \tilde{Z}) - n\mathbb{H}(\tilde{S}) - 2\epsilon \\
&\stackrel{(b)}{\geq} n\mathbb{I}(\tilde{U}, \tilde{S}; \tilde{Z}) - n\mathbb{H}(\tilde{S}) - 2\epsilon,
\end{aligned} \tag{104}$$

where (a) follows by the steps in (77) and (b) follows from the Markov chain $U - (X, S) - Z$ and from the definition of random variables \tilde{U} , \tilde{X} , \tilde{S} , \tilde{Y} , and \tilde{Z} in (103). Rewriting the bound in (104) by using the basic property in (69) leads to

$$nR \geq \mathbb{I}(\tilde{U}; \tilde{Z}|\tilde{S}) - \mathbb{H}(\tilde{S}|\tilde{Z}) - 2\epsilon. \tag{105}$$

To show that $\mathbb{D}(P_Z||Q_0) \leq \epsilon$, note that for n large enough

$$\mathbb{D}(P_Z||Q_0) = \mathbb{D}(P_{\tilde{Z}}||Q_0) = \mathbb{D}\left(\frac{1}{n} \sum_{i=1}^n P_{Z_i} \middle| \middle| Q_0\right) \leq \frac{1}{n} \sum_{i=1}^n \mathbb{D}(P_{Z_i}||Q_0) \leq \frac{1}{n} \mathbb{D}(P_{Z^n}||Q_0^{\otimes n}) \leq \frac{\delta}{n} \leq \nu \leq \epsilon. \tag{106}$$

Combining (102) and (105) shows that $\forall \epsilon_n, \nu > 0$, $R \leq \max\{x : x \in \mathcal{S}_\epsilon\}$. Therefore,

$$C_{\text{C-TR}} = \max \left\{ x : x \in \bigcap_{\epsilon > 0} \mathcal{S}_\epsilon \right\}. \tag{107}$$

2) *Continuity at Zero:* Continuity at zero for \mathcal{S}_ϵ is established by substituting $\min\{\mathbb{I}(U; Y) - \mathbb{I}(U; S), \mathbb{I}(U, V; Y) - \mathbb{I}(U; S|V)\}$ with $\mathbb{I}(U; Y|S)$ and $\mathbb{I}(V; Z) - \mathbb{I}(V; S)$ with $\mathbb{I}(U; Z|S) - \mathbb{H}(S|Z)$ in Appendix I and following the same arguments.

APPENDIX C
PROOF OF THEOREM 3

A. *Achievability Proof*

We adopt a block-Markov encoding scheme in which B independent messages are transmitted over B channel blocks each of length r , such that $n = rB$. The warden's observation is $Z^n = (Z_1^r, \dots, Z_B^r)$, the target output distribution is $Q_Z^{\otimes n}$, and Equation (81), describing the distance between the two distributions, continues to hold. The random code generation is as follows:

Fix P_X and $\epsilon_1 > \epsilon_2 > 0$ such that, $P_Z = Q_0$.

Codebook Generation for Keys: For each block $j \in \llbracket 1 : B \rrbracket$, create a function $\Phi : S_j^r \rightarrow \llbracket 1 : 2^{R_K} \rrbracket$ through random binning by choosing the value of $\Phi(s_j^r)$ independently and uniformly at random for every $s_j^r \in S^r$. The key $k_j = \Phi(s_j^r)$ obtained in block $j \in \llbracket 1 : B \rrbracket$ from the state sequence s_j^r is used to assist the encoder in the next block.

Codebook Generation for Messages: For each block $j \in \llbracket 1 : B \rrbracket$, let $C_r \triangleq \{X^r(m_j, k_{j-1})\}_{(m_j, k_{j-1}) \in \mathcal{M} \times \mathcal{K}}$, where $\mathcal{M} \in \llbracket 1 : 2^{R_M} \rrbracket$ and $\mathcal{K} \in \llbracket 1 : 2^{R_K} \rrbracket$, be a random codebook consisting of independent random sequences each generated according to $P_X^{\otimes r}$. We denote a realization of C_r by $\mathcal{C}_r \triangleq \{x^r(m_j, k_{j-1})\}_{(m_j, k_{j-1}) \in \mathcal{M} \times \mathcal{K}}$.

Encoding: For the first block, we assume that the transmitter and the receiver have access to a shared secret key k_0 , in this block to transmit m_1 the encoder computes $x^r(m_1, k_0)$ and transmits it over the channel. At the end of the first block the encoder generates a key from CSI s_1^r to be used in Block 2.

For block $j \in \llbracket 2 : B \rrbracket$, to send message m_j according to the generated key k_{j-1} from the previous block, the encoder computes $x^r(m_j, k_{j-1})$ and transmits it over the channel. Also, at the end of each block $j \in \llbracket 2 : B \rrbracket$ the encoder generates a key from CSI s_j^r to be used in next block.

Define

$$\begin{aligned} \Upsilon_{M_j, K_{j-1}, X^r, S_j^r, Z_j^r, K_j}^{(C_r)}(m_j, k_{j-1}, \tilde{x}^r, s_j^r, z_j^r, k_j) &\triangleq 2^{-r(R+R_k)} \mathbb{1}_{\{\tilde{x}^r = x^r(m_j, k_{j-1})\}} Q_S^{\otimes r}(s_j^r) \\ &\times W_{Z|X, S}^{\otimes r}(z_j^r | \tilde{x}^r, s_j^r) \mathbb{1}_{\{k_j = \Phi(s_j^r)\}}. \end{aligned} \quad (108)$$

For a fixed codebook \mathcal{C}_r , the induced joint distribution over the codebook (i.e. $P^{(C_r)}$) satisfies

$$\mathbb{D}\left(P_{M_j, K_{j-1}, X^r, S_j^r, Z_j^r, K_j}^{(C_r)} \parallel \Upsilon_{M_j, K_{j-1}, X^r, S_j^r, Z_j^r, K_j}^{(C_r)}\right) \leq \epsilon. \quad (109)$$

This intermediate distribution $\Upsilon^{(C_r)}$ approximates the true distribution $P^{(C_r)}$ and will be used in the sequel for bounding purposes. Expression (109) holds because the main difference in $\Upsilon^{(C_r)}$ is assuming the key K_{j-1} is uniformly distributed, which is made (arbitrarily) nearly uniform in $P^{(C_r)}$ with appropriate control of rate.

Covert Analysis: We now show that this coding scheme guarantees that $\mathbb{E}_{C_n}[\mathbb{D}(P_{Z^n|C_n} \parallel Q_Z^{\otimes n})] \xrightarrow[n \rightarrow \infty]{} 0$, where C_n is the set of all the codebooks for all blocks, and then choose P_X such that it satisfies $Q_Z = Q_0$.

Similar to (88), by using the functional dependence graph depicted in Fig. 9,

$$\mathbb{D}(P_{Z^n|C_n} \parallel Q_Z^{\otimes n}) \leq 2 \sum_{j=1}^B \mathbb{D}(P_{Z_j^r, K_j|C_r} \parallel Q_Z^{\otimes r} Q_{K_j}). \quad (110)$$

We now proceed to bound the right hand side of (110). First, consider the marginal

$$\Upsilon_{Z_j^r, K_j|C_r}(z_j^r, k_j) = \sum_{m_j} \sum_{k_{j-1}} \sum_{s_j^r} \frac{1}{2^{r(R+R_k)}} Q_S^{\otimes r}(s_j^r) W_{Z|X, S}^{\otimes r}(z_j^r | X^r(m_j, k_{j-1}), s_j^r) \mathbb{1}_{\{k_j = \Phi(s_j^r)\}}. \quad (111)$$

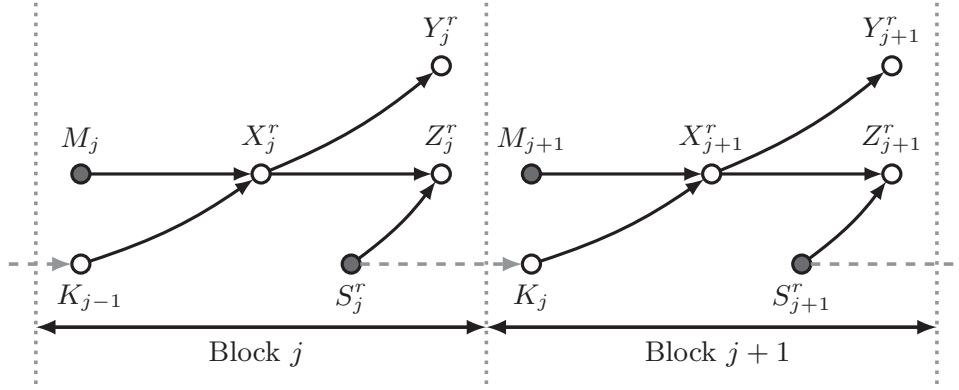

Fig. 9. Functional dependence graph for the block-Markov encoding scheme

To bound the RHS of (110) by using Lemma 1 and the triangle inequality we have

$$\mathbb{E}_{C_r} \|P_{Z_j^r, K_j | C_r} - Q_Z^{\otimes r} Q_{K_j}\|_1 \leq \mathbb{E}_{C_r} \|P_{Z_j^r, K_j | C_r} - \Upsilon_{Z_j^r, K_j | C_r}\|_1 + \mathbb{E}_{C_r} \|\Upsilon_{Z_j^r, K_j | C_r} - Q_Z^{\otimes r} Q_{K_j}\|_1. \quad (112)$$

From Lemma 1 and (109) the first term on the RHS of (112) vanishes as r grows; to bound the second term by using Lemma 1 we have,

$$\begin{aligned} \mathbb{E}_{C_r} [\mathbb{D}(\Upsilon_{Z_j^r, K_j | C_r} \| Q_Z^{\otimes r} Q_{K_j})] &= \mathbb{E}_{C_r} \left[\sum_{(z_j^r, k_j)} \Upsilon_{Z_j^r, K_j | C_r}(z_j^r, k_j) \log \left(\frac{\Upsilon_{Z_j^r, K_j | C_r}(z_j^r, k_j)}{Q_Z^{\otimes r}(z_j^r) Q_{K_j}(k_j)} \right) \right] \\ &= \mathbb{E}_{C_r} \left[\sum_{(z_j^r, k_j)} \sum_{m_j} \sum_{k_{j-1}} \frac{1}{2^{r(R+R_k)}} \sum_{s_j^r} Q_S^{\otimes r}(s_j^r) W_{Z|X,S}^{\otimes r}(z_j^r | X^r(m_j, k_{j-1}), s_j^r) \mathbb{1}_{\{k_j = \Phi(s_j^r)\}} \right. \\ &\quad \left. \times \log \left(\frac{\sum_{\tilde{m}_j} \sum_{\tilde{k}_{j-1}} \sum_{\tilde{s}_j^r} Q_S^{\otimes r}(\tilde{s}_j^r) W_{Z|X,S}^{\otimes r}(z_j^r | X^r(\tilde{m}_j, \tilde{k}_{j-1}), \tilde{s}_j^r) \mathbb{1}_{\{k_j = \Phi(\tilde{s}_j^r)\}}}{2^{r(R+R_k - R_K)} Q_Z^{\otimes r}(z_j^r)} \right) \right] \\ &\stackrel{(a)}{\leq} \sum_{(z_j^r, k_j)} \sum_{m_j} \sum_{k_{j-1}} \frac{1}{2^{r(R+R_k)}} \sum_{s_j^r} \sum_{x^r(m_j, k_{j-1})} \Upsilon_{X^r, S^r, Z^r}^{(C_r)}(x^r(m_j, k_{j-1}), s_j^r, z_j^r) \times \mathbb{E}_{\Phi(s_j^r)} [\mathbb{1}_{\{k_j = \Phi(s_j^r)\}}] \\ &\quad \times \log \mathbb{E}_{\setminus((m_j, k_{j-1}), \Phi(s_j^r))} \left[\frac{\sum_{\tilde{m}_j} \sum_{\tilde{k}_{j-1}} \sum_{\tilde{s}_j^r} Q_S^{\otimes r}(\tilde{s}_j^r) W_{Z|X,S}^{\otimes r}(z_j^r | X^r(\tilde{m}_j, \tilde{k}_{j-1}), \tilde{s}_j^r) \mathbb{1}_{\{k_j = \Phi(\tilde{s}_j^r)\}}}{2^{r(R+R_k - R_K)} Q_Z^{\otimes r}(z_j^r)} \right] \\ &\stackrel{(b)}{\leq} \sum_{(z_j^r, k_j)} \sum_{m_j} \sum_{k_{j-1}} \frac{1}{2^{r(R+R_k)}} \sum_{s_j^r} \sum_{x^r(m_j, k_{j-1})} \Upsilon_{X^r, S^r, Z^r}^{(C_r)}(x^r(m_j, k_{j-1}), s_j^r, z_j^r) \times \frac{1}{2^{rR_K}} \\ &\quad \times \log \frac{1}{2^{r(R+R_k - R_K)} Q_Z^{\otimes r}(z_j^r)} \left(Q_S^{\otimes r}(s_j^r) W_{Z|X,S}^{\otimes r}(z_j^r | x^r(m_j, k_{j-1}), s_j^r) \right. \\ &\quad \left. + \mathbb{E}_{\setminus(m_j, k_{j-1})} \left[\sum_{(\tilde{m}_j, \tilde{k}_{j-1}) \neq (m_j, k_{j-1})} Q_S^{\otimes r}(s_j^r) W_{Z|X,S}^{\otimes r}(z_j^r | X^r(\tilde{m}_j, \tilde{k}_{j-1}), s_j^r) \right] \right. \\ &\quad \left. + \mathbb{E}_{\setminus\Phi(s_j^r)} \left[\sum_{\tilde{s}_j^r \neq s_j^r} Q_S^{\otimes r}(\tilde{s}_j^r) \times W_{Z|X,S}^{\otimes r}(z_j^r | x^r(m_j, k_{j-1}), \tilde{s}_j^r) \mathbb{1}_{\{k_j = \Phi(\tilde{s}_j^r)\}} \right] \right. \\ &\quad \left. + \mathbb{E}_{\setminus((m_j, k_{j-1}), \Phi(s_j^r))} \left[\sum_{\tilde{s}_j^r \neq s_j^r} \sum_{(\tilde{m}_j, \tilde{k}_{j-1}) \neq (m_j, k_{j-1})} Q_S^{\otimes r}(\tilde{s}_j^r) W_{Z|X,S}^{\otimes r}(z_j^r | X^r(\tilde{m}_j, \tilde{k}_{j-1}), \tilde{s}_j^r) \mathbb{1}_{\{k_j = \Phi(\tilde{s}_j^r)\}} \right] \right) \end{aligned}$$

$$\begin{aligned}
&\stackrel{(c)}{\leq} \sum_{(z_j^r, k_j)} \sum_{m_j} \sum_{k_{j-1}} \frac{1}{2^{r(R+R_k+R_K)}} \sum_{s_j^r} \sum_{x^r(m_j, k_{j-1})} \Upsilon_{X^r, S^r, Z^r}^{(C_r)}(x^r(m_j, k_{j-1}), s_j^r, z_j^r) \\
&\quad \times \log \left(\frac{Q_S^{\otimes r}(s_j^r) W_{Z|X, S}^{\otimes r}(z_j^r | x^r(m_j, k_{j-1}), s_j^r)}{2^{r(R+R_k-R_K)} Q_Z^{\otimes r}(z_j^r)} + \sum_{(\tilde{m}_j, \tilde{k}_{j-1}) \neq (m_j, k_{j-1})} \frac{Q_{S, Z}^{\otimes r}(s_j^r, z_j^r)}{2^{r(R+R_k-R_K)} Q_Z^{\otimes r}(z_j^r)} \right. \\
&\quad \left. + \sum_{\tilde{s}_j^r \neq s_j^r} \frac{Q_S^{\otimes r}(\tilde{s}_j^r) W_{Z|X, S}^{\otimes r}(z_j^r | x^r(m_j, k_{j-1}), \tilde{s}_j^r)}{2^{r(R+R_k)} Q_Z^{\otimes r}(z_j^r)} + 1 \right) \\
&\leq \sum_{(z_j^r, k_j)} \sum_{m_j} \sum_{k_{j-1}} \frac{1}{2^{r(R+R_k+R_K)}} \sum_{s_j^r} \sum_{x^r(m_j, k_{j-1})} \Upsilon_{X^r, S^r, Z^r}^{(C_r)}(x^r(m_j, k_{j-1}), s_j^r, z_j^r) \\
&\quad \times \log \left(\frac{Q_S^{\otimes r}(s_j^r) W_{Z|X, S}^{\otimes r}(z_j^r | x^r(m_j, k_{j-1}), s_j^r)}{2^{r(R+R_k-R_K)} Q_Z^{\otimes r}(z_j^r)} + \frac{2^{rR_K} Q_{S, Z}^{\otimes r}(s_j^r, z_j^r)}{Q_Z^{\otimes r}(z_j^r)} + \frac{W_{Z|X}^{\otimes r}(z_j^r | x^r(m_j, k_{j-1}))}{2^{r(R+R_k)} Q_Z^{\otimes r}(z_j^r)} + 1 \right) \\
&\triangleq \Psi_1 + \Psi_2, \tag{113}
\end{aligned}$$

where (a) follows from Jensen's inequality, (b) and (c) are because $\mathbb{1}_{\{\cdot\}} \leq 1$, and the last term in the RHS of (b) is smaller than 1. We defined Ψ_1 and Ψ_2 as

$$\begin{aligned}
\Psi_1 &= \sum_{k_j} \sum_{k_{j-1}} \sum_{m_j} \frac{1}{2^{r(R+R_k+R_K)}} \sum_{(x^r(m_j, k_{j-1}), s_j^r, z_j^r) \in \mathcal{T}_\epsilon^{(n)}} \Upsilon_{X^r, S^r, Z^r}^{(C_r)}(x^r(m_j, k_{j-1}), s_j^r, z_j^r) \\
&\quad \times \log \left(\frac{Q_S^{\otimes r}(s_j^r) W_{Z|X, S}^{\otimes r}(z_j^r | x^r(m_j, k_{j-1}), s_j^r)}{2^{r(R+R_k-R_K)} Q_Z^{\otimes r}(z_j^r)} + \frac{2^{rR_K} Q_{S, Z}^{\otimes r}(s_j^r, z_j^r)}{Q_Z^{\otimes r}(z_j^r)} + \frac{W_{Z|X}^{\otimes r}(z_j^r | x^r(m_j, k_{j-1}))}{2^{r(R+R_k)} Q_Z^{\otimes r}(z_j^r)} + 1 \right) \\
&\leq \log \left(\frac{2^{rR_K} 2^{-r(1-\epsilon)} (\mathbb{H}(S) + \mathbb{H}(Z|X, S))}{2^{r(R+R_k)} 2^{-r(1+\epsilon)} \mathbb{H}(Z)} + \frac{2^{rR_K} 2^{-r(1-\epsilon)} \mathbb{H}(S, Z)}{2^{-r(1+\epsilon)} \mathbb{H}(Z)} + \frac{2^{-r(1-\epsilon)} \mathbb{H}(Z|X)}{2^{r(R+R_k)} 2^{-r(1+\epsilon)} \mathbb{H}(Z)} + 1 \right) \tag{114}
\end{aligned}$$

$$\begin{aligned}
\Psi_2 &= \sum_{k_j} \sum_{k_{j-1}} \sum_{m_j} \frac{1}{2^{r(R+R_k+R_K)}} \sum_{(x^r(m_j, k_{j-1}), s_j^r, z_j^r) \notin \mathcal{T}_\epsilon^{(n)}} \Upsilon_{X^r, S^r, Z^r}^{(C_r)}(x^r(m_j, k_{j-1}), s_j^r, z_j^r) \\
&\quad \times \log \left(\frac{Q_S^{\otimes r}(s_j^r) W_{Z|X, S}^{\otimes r}(z_j^r | x^r(m_j, k_{j-1}), s_j^r)}{2^{r(R+R_k-R_K)} Q_Z^{\otimes r}(z_j^r)} + \frac{2^{rR_K} Q_{S, Z}^{\otimes r}(s_j^r, z_j^r)}{Q_Z^{\otimes r}(z_j^r)} + \frac{W_{Z|X}^{\otimes r}(z_j^r | x^r(m_j, k_{j-1}))}{2^{r(R+R_k)} Q_Z^{\otimes r}(z_j^r)} + 1 \right) \\
&\leq 2|X||S||Z| e^{-r\epsilon^2 \mu_{X, S, Z}} r \log \left(\frac{3}{\mu_Z} + 1 \right), \tag{115}
\end{aligned}$$

where $\mu_{X, S, Z} = \min_{(x, s, z) \in (\mathcal{X}, \mathcal{S}, \mathcal{Z})} P_{X, S, Z}(x, s, z)$ and $\mu_Z = \min_{z \in \mathcal{Z}} P_Z(z)$. When $r \rightarrow \infty$ then $\Psi_2 \rightarrow 0$, by choosing $R_K = \mathbb{H}(S|Z) - \epsilon$, Ψ_1 vanishes when r grows if,

$$R + R_k > \mathbb{I}(X; Z|S), \tag{116a}$$

$$R + R_k > \mathbb{I}(X; Z). \tag{116b}$$

Here (116b) is redundant because of (116a) and the fact that X and S are independent.

Decoding and Error Probability Analysis: At the end of block $j \in \llbracket 1 : B \rrbracket$, using its knowledge of the channel state s_j^r of the current block and the key k_{j-1} generated from the previous block, the receiver finds a unique \hat{m}_j such that $(u^r(\hat{m}_j, k_{j-1}), s_j^r, y_j^r) \in \mathcal{T}_\epsilon^{(r)}$. To analyze the probability of error we define the following error events for $j \in \llbracket 1 : B \rrbracket$

$$\mathcal{E} = \{\hat{M} \neq M\}, \tag{117a}$$

$$\mathcal{E}_j = \{\hat{M}_j \neq M_j\}, \tag{117b}$$

$$\mathcal{E}_{1,j} = \{(X^r(M_j, K_{j-1}), S_j^r) \notin \mathcal{T}_{\epsilon_1}^{(r)}(Q_S P_X)\}, \quad (117c)$$

$$\mathcal{E}_{2,j} = \{(X^r(M_j, K_{j-1}), S_j^r, Y_j^r) \notin \mathcal{T}_{\epsilon_2}^{(r)}(Q_S P_X W_{Y|X,S})\}, \quad (117d)$$

$$\mathcal{E}_{3,j} = \{(X^r(k_{j-1}, \hat{m}_j), S_j^r, Y_j^r) \in \mathcal{T}_{\epsilon_2}^{(r)}, \text{ for some } \hat{m}_j \neq M_j\}, \quad (117e)$$

where $\epsilon_2 > \epsilon_1 > \epsilon > 0$. The probability of error is upper bounded as follows,

$$\mathbb{P}(\mathcal{E}) \leq \mathbb{P}\left\{\bigcup_{j=1}^B \mathcal{E}_j\right\} \leq \sum_{j=1}^B \mathbb{P}(\mathcal{E}_j). \quad (118)$$

Now we bound $\mathbb{P}(\mathcal{E}_j)$ by using union bound

$$\mathbb{P}(\mathcal{E}_j) \leq \mathbb{P}(\mathcal{E}_{1,j}) + \mathbb{P}(\mathcal{E}_{1,j}^c \cap \mathcal{E}_{2,j}) + \mathbb{P}(\mathcal{E}_{2,j}^c \cap \mathcal{E}_{3,j}). \quad (119)$$

By the law of large numbers the first and second term on RHS of (119) vanishes when r grows. According to the law of large numbers and the packing lemma, the last term on RHS of (119) vanishes when r grows if [31],

$$R < \mathbb{I}(X; S, Y) = \mathbb{I}(X; Y|S). \quad (120)$$

Furthermore, this scheme requires that,

$$R_k \leq R_K = \mathbb{H}(S|Z) - \epsilon. \quad (121)$$

The region in Theorem 3 is obtained by applying Fourier-Motzkin to (116a), (120), and (121).

B. Converse Proof

To establish the upper bound, consider any sequence of length- n codes for a state-dependent channel with channel state available strictly causally at both the transmitter and the receiver such that $P_e^{(n)} \leq \epsilon_n$ and $\mathbb{D}(P_{Z^n} || Q_0^{\otimes n}) \leq \delta$ with $\lim_{n \rightarrow \infty} \epsilon_n = 0$. Note that the converse is consistent with the model and does *not* require δ to vanish.

1) *Epsilon Rate Region:* We first define a region \mathcal{S}_ϵ for $\epsilon > 0$ that expands the region defined in (10) as follows.

$$\mathcal{S}_\epsilon \triangleq \{R \geq 0 : \exists P_{S,X,Y,Z} \in \mathcal{D}_\epsilon : R \leq \mathbb{I}(X; Y|S) + \epsilon\} \quad (122a)$$

where

$$\mathcal{D}_\epsilon = \left\{ \begin{array}{l} P_{S,X,Y,Z} : \\ P_{S,X,Y,Z} = Q_S P_X W_{Y,Z|X,S} \\ \mathbb{D}(P_Z || Q_0) \leq \epsilon \\ \mathbb{H}(S|Z) > \mathbb{I}(X; Z|S) - \mathbb{I}(X; Y|S) - 3\epsilon \end{array} \right\}, \quad (122b)$$

where $\epsilon \triangleq \max\{\epsilon_n, \nu \geq \frac{\delta}{n}\}$. We next show that if a rate R is achievable then $R \in \mathcal{S}_\epsilon$ for any $\epsilon > 0$.

For any $\epsilon_n > 0$, we start by upper bounding nR using standard techniques.

$$\begin{aligned} nR &= \mathbb{H}(M) \\ &\stackrel{(a)}{\leq} \mathbb{H}(M|S^n) - \mathbb{H}(M|Y^n, S^n) + n\epsilon_n \\ &= \mathbb{I}(M; Y^n|S^n) + n\epsilon_n \end{aligned}$$

$$\begin{aligned}
&= \sum_{i=1}^n \mathbb{I}(M; Y_i | Y^{i-1}, S^n) + n\epsilon_n \\
&\leq \sum_{i=1}^n [\mathbb{H}(Y_i | Y^{i-1}, S^n) - \mathbb{H}(Y_i | Y^{i-1}, S^n, X_i, M)] + n\epsilon_n \\
&\stackrel{(b)}{\leq} \sum_{i=1}^n \mathbb{I}(X_i; Y_i | S_i) + n\epsilon_n \\
&\stackrel{(c)}{\leq} n\mathbb{I}(\tilde{X}; \tilde{Y} | \tilde{S}) + n\epsilon_n \\
&\stackrel{(d)}{\leq} n\mathbb{I}(\tilde{X}; \tilde{Y} | \tilde{S}) + n\epsilon, \tag{123}
\end{aligned}$$

where

- (a) follows from Fano's inequality and independence of M from S^n ;
- (b) holds because conditioning does not increase entropy and $(M, Y^{i-1}, S^n, X_{\sim i}, Y_{\sim i}) - (X_i, S_i) - Y_i$ forms a Markov chain;
- (c) follows from concavity of mutual information, with respect to the input distribution, with the random variables \tilde{X} , \tilde{S} , \tilde{Y} , and \tilde{Z} having the following distributions

$$\tilde{P}_{X,S}(x, s) \triangleq \frac{1}{n} \sum_{i=1}^n P_{X_i, S_i}(x, s), \tag{124a}$$

$$\tilde{P}_{X,S,Y,Z}(x, s, y, z) \triangleq \tilde{P}_{X,S}(x, s) W_{Y,Z|X,S}(y, z|x, s), \tag{124b}$$

- (d) follows by defining $\epsilon \triangleq \max\{\epsilon_n, \nu \geq \frac{\delta}{n}\}$.

By following the same steps as in (77) we also have,

$$nR \geq n\mathbb{I}(\tilde{X}, \tilde{S}; \tilde{Z}) - n\mathbb{H}(\tilde{S}) - 2\epsilon, \tag{125}$$

where the random variables \tilde{X} , \tilde{S} , \tilde{Y} , and \tilde{Z} have been defined in (124). Substituting (69) into (125) leads to

$$R \geq \mathbb{I}(\tilde{X}; \tilde{Z} | \tilde{S}) - \mathbb{H}(\tilde{S} | \tilde{Z}) - 2\epsilon. \tag{126}$$

To show that $\mathbb{D}(P_Z || Q_0) \leq \epsilon$, note that for n large enough

$$\mathbb{D}(P_Z || Q_0) = \mathbb{D}(P_{\tilde{Z}} || Q_0) = \mathbb{D}\left(\frac{1}{n} \sum_{i=1}^n P_{Z_i} \middle| \middle| Q_0\right) \leq \frac{1}{n} \sum_{i=1}^n \mathbb{D}(P_{Z_i} || Q_0) \leq \frac{1}{n} \mathbb{D}(P_{Z^n} || Q_0^{\otimes n}) \leq \frac{\delta}{n} \leq \nu \leq \epsilon. \tag{127}$$

Combining (123) and (126) shows that $\forall \epsilon_n, \nu > 0$, $R \leq \max\{x : x \in \mathcal{S}_\epsilon\}$. Therefore,

$$C_{\text{SC-TR}} = \max \left\{ x : x \in \bigcap_{\epsilon > 0} \mathcal{S}_\epsilon \right\}. \tag{128}$$

2) *Continuity at Zero*: One can prove the continuity at zero of \mathcal{S}_ϵ by substituting $\min\{\mathbb{I}(U; Y) - \mathbb{I}(U; S), \mathbb{I}(U; V; Y) - \mathbb{I}(U; S|V)\}$ with $\mathbb{I}(X; Y|S)$ and $\mathbb{I}(V; Z) - \mathbb{I}(V; S)$ with $\mathbb{I}(X; Z|S) - \mathbb{H}(S|Z)$ in Appendix I and following the exact same arguments.

APPENDIX D
PROOF OF THEOREM 4

We adopt a block-Markov encoding scheme in which B independent messages are transmitted over B channel blocks each of length r , such that $n = rB$. The warden's observation is $Z^n = (Z_1^r, \dots, Z_B^r)$, the distribution induced at the output of the warden is P_{Z^n} , the target output distribution is $Q_Z^{\otimes n}$, and Equation (81), describing the distance between the two distributions, continues to hold. The random code generation is as follows:

Fix $P_{U|S}(u|s)$, $P_{V|S}(v|s)$, $x(u, s)$, and $\epsilon_1 > \epsilon_2 > 0$ such that, $P_Z = Q_0$.

Codebook Generation for Keys: For each block $j \in \llbracket 1 : B \rrbracket$, let $C_1^{(r)} \triangleq \{V^r(a_j)\}_{a_j \in \mathcal{A}}$, where $\mathcal{A} = \llbracket 1 : 2^{r\tilde{R}} \rrbracket$, be a random codebook consisting of independent random sequences each generated according to $P_V^{\otimes r}$, where $P_V = \sum_{s \in \mathcal{S}} Q_S(s)P_{V|S}(v|s)$. We denote a realization of $C_1^{(r)}$ by $\mathcal{C}_1^{(r)} \triangleq \{v^r(a_j)\}_{a_j \in \mathcal{A}}$. Partition the set of indices $a_j \in \llbracket 1 : 2^{r\tilde{R}} \rrbracket$ into bins $\mathcal{B}(t)$, $t \in \llbracket 1 : 2^{rR_t} \rrbracket$ by using function $\varphi : V^r(a_j) \rightarrow \llbracket 1 : 2^{rR_t} \rrbracket$ through random binning by choosing the value of $\varphi(v^r(a_j))$ independently and uniformly at random for every $v^r(a_j) \in \mathcal{V}^r$. For each block $j \in \llbracket 1 : B \rrbracket$, create a function $\Phi : V^r(a_j) \rightarrow \llbracket 1 : 2^{rR_k} \rrbracket$ through random binning by choosing the value of $\Phi(v^r(a_j))$ independently and uniformly at random for every $v^r(a_j) \in \mathcal{V}^r$. The key $k_j = \Phi(v^r(a_j))$ obtained in block $j \in \llbracket 1 : B \rrbracket$ from the description of the channel state sequence $v^r(a_j)$ is used to assist the encoder in block $j+2$.

Codebook Generation for Messages: For each block $j \in \llbracket 1 : B \rrbracket$, let $C_2^{(r)} \triangleq \{U^r(m_j, t_{j-1}, k_{j-2}, \ell_j)\}_{(m_j, t_{j-1}, k_{j-2}, \ell_j) \in \mathcal{M} \times \mathcal{T} \times \mathcal{K} \times \mathcal{L}}$, where $\mathcal{M} = \llbracket 1 : 2^{rR} \rrbracket$, $\mathcal{T} = \llbracket 1 : 2^{rR_t} \rrbracket$, $\mathcal{K} = \llbracket 1 : 2^{rR_k} \rrbracket$, and $\mathcal{L} = \llbracket 1 : 2^{rR_\ell} \rrbracket$, be a random codebook consisting of independent random sequences each generated according to $P_U^{\otimes r}$. We denote a realization of $C_2^{(r)}$ by $\mathcal{C}_2^{(r)} \triangleq \{u^r(m_j, t_{j-1}, k_{j-2}, \ell_j)\}_{(m_j, t_{j-1}, k_{j-2}, \ell_j) \in \mathcal{M} \times \mathcal{T} \times \mathcal{K} \times \mathcal{L}}$. Let, $C_r = \{C_1^{(r)}, C_2^{(r)}\}$ and $\mathcal{C}_r = \{\mathcal{C}_1^{(r)}, \mathcal{C}_2^{(r)}\}$. The indices $(m_j, t_{j-1}, k_{j-2}, \ell_j)$ can be viewed as a three layer binning. We define an ideal PMF for codebook \mathcal{C}_r , as an approximate distribution to facilitate the analysis

$$\begin{aligned} & \Gamma_{M_j, T_{j-1}, K_{j-2}, L_j, A_j, U^r, V^r, S_j^r, Z_j^r, K_{j-1}, T_j, K_j}^{(C_r)}(m_j, t_{j-1}, k_{j-2}, \ell_j, a_j, \tilde{u}^r, \tilde{v}_j^r, s_j^r, z_j^r, k_{j-1}, t_j, k_j) \\ &= 2^{-r(R+R_t+R_k+R_\ell+\tilde{R})} \mathbb{1}_{\{\tilde{u}^r = u^r(m_j, t_{j-1}, k_{j-2}, \ell_j)\}} \mathbb{1}_{\{\tilde{v}_j^r = v^r(a_j)\}} P_{S|U,V}^{\otimes r}(s_j^r | \tilde{u}^r, \tilde{v}_j^r) \\ & \quad \times W_{Z|U,S}^{\otimes r}(z_j^r | \tilde{u}^r, s_j^r) 2^{-rR_k} \mathbb{1}_{\{t_j = \sigma(\tilde{v}_j^r)\}} \mathbb{1}_{\{k_j = \Phi(\tilde{v}_j^r)\}}, \end{aligned} \quad (129)$$

where $W_{Z|U,S}$ is the marginal distribution $W_{Z|U,S} = \sum_{x \in \mathcal{X}} \mathbb{1}_{\{x=x(u,s)\}} W_{Z|X,S}$ and $P_{S|U,V}$ is defined as follows

$$P_{S|U,V}(s|u, v) \triangleq \frac{P_{S,U,V}(s, u, v)}{P_{U,V}(u, v)} = \frac{Q_S(s)P_{U|S}(u|s)P_{V|S}(v|s)}{\sum_{s \in \mathcal{S}} Q_S(s)P_{U|S}(u|s)P_{V|S}(v|s)}. \quad (130)$$

Encoding:

We assume that the transmitter and the receiver have access to shared secret keys k_{-1} and k_0 for the first two blocks but after the first two blocks they use the key that they generate from the CSI.

In the first block, to send the message m_1 according to k_{-1} , the encoder chooses the index t_0 uniformly at random and then chooses the indices ℓ_1 and a_1 according to the following distribution with $j = 1$,

$$f(\ell_j, a_j | s_j^r, m_j, t_{j-1}, k_{j-2}) = \frac{P_{S|U,V}^{\otimes r}(s_j^r | u^r(m_j, t_{j-1}, k_{j-2}, \ell_j), v^r(a_j))}{\sum_{\ell'_j \in \llbracket 1 : 2^{rR_\ell} \rrbracket} \sum_{a'_j \in \llbracket 1 : 2^{r\tilde{R}} \rrbracket} P_{S|U,V}^{\otimes r}(s_j^r | u^r(m_j, t_{j-1}, k_{j-2}, \ell'_j), v^r(a'_j))}, \quad (131)$$

where $P_{S|U,V}$ is defined in (130). Based on these indices, the encoder computes $u^r(m_1, t_0, k_{-1}, \ell_1)$ and $v^r(a_1)$ and transmits codeword x^r , where $x_i = x(u_i(m_1, t_0, k_{-1}, \ell_1), s_i)$. Note that, the index t_0 does not convey any useful

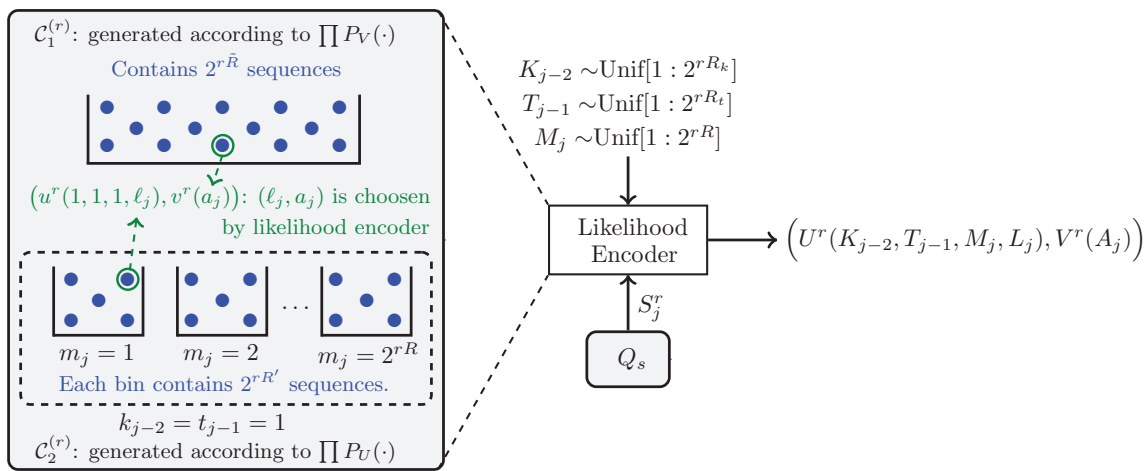

Fig. 10. Proposed coding scheme for the dual use of CSI

information. Simultaneously, it uses the description of its CSI $v^r(a_1)$ to generate a reconciliation index t_1 and a key k_1 to be used in the second and the third blocks, respectively.

In the second block, to send the message m_2 and reconciliation index t_1 according to k_0 , the encoder chooses the indices ℓ_2 and a_2 according to the likelihood encoder described in (131) with $j = 2$. Based on these indices the encoder computes $u^r(m_2, t_1, k_0, \ell_2)$ and $v^r(a_2)$ and transmits codeword x^r , where $x_i = x(u_i(m_2, t_1, k_0, \ell_1), s_i)$. Simultaneously, it uses the description of its CSI $v^r(a_2)$ to generate a reconciliation index t_2 and a key k_2 to be used in the third and the fourth block, respectively.

In block $j \in \llbracket 3 : B \rrbracket$, to send the message m_j and reconciliation index t_{j-1} , generated in the previous block, according to the generated key k_{j-2} from the the block $j - 2$ and the CSI of the current block, the encoder selects indices ℓ_j and a_j from bin (m_j, t_{j-1}, k_{j-2}) according to the likelihood encoder described in (131). The encoder then transmits codeword x^r , where each coordinate of the transmitted signal is a function of the state, as well as the corresponding sample of the transmitter's codeword u_i , i.e., $x_i = x(u_i(m_j, t_{j-1}, k_{j-2}, \ell_j), s_i)$. Simultaneously, the encoder uses the description of its CSI $v^r(a_j)$ to generate a reconciliation index t_j and a key k_j to be used in the block $j + 1$ and the block $j + 2$, respectively. The encoding scheme in block $j \in \llbracket 3 : B \rrbracket$ is depicted in Fig. 10.

Define

$$\begin{aligned} & \Upsilon_{M_j, T_{j-1}, K_{j-2}, S_j^r, L_j, A_j, U^r, V^r, Z_j^r, K_{j-1}, T_j, K_j}^{(C_r)}(m_j, t_{j-1}, k_{j-2}, s_j^r, \ell_j, a_j, \tilde{u}^r, \tilde{v}^r, z_j^r, k_{j-1}, t_j, k_j) \\ & \triangleq 2^{-r(R+R_t+R_k)} Q_S^{\otimes r}(s_j^r) f(\ell_j, a_j | s_j^r, m_j, t_{j-1}, k_{j-2}) \mathbb{1}_{\{\tilde{u}^r = u^r(m_j, t_{j-1}, k_{j-2}, \ell_j)\}} \mathbb{1}_{\{\tilde{v}^r = v^r(a_j)\}} \\ & \times W_{Z|U, S}^{\otimes r}(z_j^r | \tilde{u}^r, s_j^r) 2^{-rR_k} \mathbb{1}_{\{t_j = \sigma(\tilde{v}^r)\}} \mathbb{1}_{\{k_j = \Phi(\tilde{v}^r)\}}. \end{aligned} \quad (132)$$

For a given codebook C_r , the induced joint distribution over the codebook (i.e. $P^{(C_r)}$) satisfies

$$\mathbb{D}\left(P_{M_j, T_{j-1}, K_{j-2}, S_j^r, L_j, A_j, U^r, V^r, Z_j^r, K_{j-1}, T_j, K_j}^{(C_r)} \parallel \Upsilon_{M_j, T_{j-1}, K_{j-2}, S_j^r, L_j, A_j, U^r, V^r, Z_j^r, K_{j-1}, T_j, K_j}^{(C_r)}\right) \leq \epsilon. \quad (133)$$

This intermediate distribution $\Upsilon^{(C_r)}$ approximates the true distribution $P^{(C_r)}$ and will be used in the sequel for bounding purposes. Expression (133) holds because the main difference in $\Upsilon^{(C_r)}$ is assuming the keys K_{j-2} , K_{j-1} and the reconciliation index T_{j-1} are uniformly distributed, which is made (arbitrarily) nearly uniform in $P^{(C_r)}$ with appropriate control of rate.

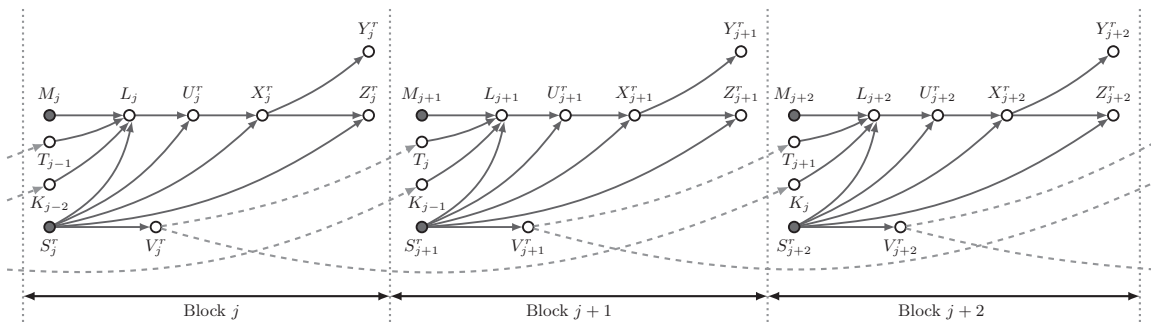

Fig. 11. Functional dependence graph for the block-Markov encoding scheme

Covert Analysis: We now show $\mathbb{E}_{C_n} [\mathbb{D}(P_{Z^n|C_n} \| Q_Z^{\otimes n})] \xrightarrow{n \rightarrow \infty} 0$, where C_n is the set of all the codebooks for all blocks, and then choose P_U , P_V , and $x(u, s)$ such that it satisfies $Q_Z = Q_0$. From the expansion in (81), for every $j \in [2 : B]$,

$$\begin{aligned} \mathbb{I}(Z_j^r; Z_{j+1}^{B,r}) &\leq \mathbb{I}(Z_j^r; K_{j-1}, T_j, K_j, Z_{j+1}^{B,r}) \\ &\stackrel{(a)}{=} \mathbb{I}(Z_j^r; K_{j-1}, T_j, K_j), \end{aligned} \quad (134)$$

where (a) holds because $Z_j^r - (K_{j-1}, T_j, K_j) - Z_{j+1}^{B,r}$ forms a Markov chain, as seen in the functional dependence graph depicted in Fig. 11. Also,

$$\begin{aligned} \mathbb{I}(Z_j^r; K_{j-1}, T_j, K_j) &= \mathbb{D}(P_{Z_j^r, K_{j-1}, T_j, K_j} \| P_{Z_j^r} P_{K_{j-1}, T_j, K_j}) \\ &\stackrel{(b)}{\leq} \mathbb{D}(P_{Z_j^r, K_{j-1}, T_j, K_j} \| Q_Z^{\otimes r} Q_{K_{j-1}} Q_{T_j} Q_{K_j}), \end{aligned} \quad (135)$$

where $Q_{K_{j-1}} Q_{K_j} Q_{T_j}$ is the uniform distribution on $[1 : 2^{R_k}] \times [1 : 2^{R_\kappa}] \times [1 : 2^{R_T}]$ and (b) follows from

$$\begin{aligned} \mathbb{D}(P_{Z_j^r, K_{j-1}, T_j, K_j} \| P_{Z_j^r} P_{K_{j-1}, T_j, K_j}) &= \mathbb{D}(P_{Z_j^r, K_{j-1}, T_j, K_j} \| Q_Z^{\otimes r} Q_{K_{j-1}} Q_{T_j} Q_{K_j}) \\ &\quad - \mathbb{D}(P_{Z_j^r} \| Q_Z^{\otimes r}) - \mathbb{D}(P_{K_{j-1}, T_j, K_j} \| Q_{K_{j-1}} Q_{T_j} Q_{K_j}). \end{aligned} \quad (136)$$

Therefore, by combining (81), (135), and (136)

$$\mathbb{D}(P_{Z^n} \| Q_Z^{\otimes n}) \leq 2 \sum_{j=1}^B \mathbb{D}(P_{Z_j^r, K_{j-1}, T_j, K_j} \| Q_Z^{\otimes r} Q_{K_{j-1}} Q_{T_j} Q_{K_j}). \quad (137)$$

To bound the RHS of (137) by using Lemma 1 and the triangle inequality we have,

$$\begin{aligned} \mathbb{E}_{C_r} \| P_{Z_j^r, K_{j-1}, T_j, K_j | C_r} - Q_Z^{\otimes r} Q_{K_{j-1}} Q_{T_j} Q_{K_j} \|_1 &\leq \mathbb{E}_{C_r} \| P_{Z_j^r, K_{j-1}, T_j, K_j | C_r} - \Gamma_{Z_j^r, K_{j-1}, T_j, K_j | C_r} \|_1 \\ &\quad + \mathbb{E}_{C_r} \| \Gamma_{Z_j^r, K_{j-1}, T_j, K_j | C_r} - Q_Z^{\otimes r} Q_{K_{j-1}} Q_{T_j} Q_{K_j} \|_1 \\ &\leq \mathbb{E}_{C_r} \| P_{Z_j^r, K_{j-1}, T_j, K_j | C_r} - \Upsilon_{Z_j^r, K_{j-1}, T_j, K_j | C_r} \|_1 + \mathbb{E}_{C_r} \| \Upsilon_{Z_j^r, K_{j-1}, T_j, K_j | C_r} - \Gamma_{Z_j^r, K_{j-1}, T_j, K_j | C_r} \|_1 \\ &\quad + \mathbb{E}_{C_r} \| \Gamma_{Z_j^r, K_{j-1}, T_j, K_j | C_r} - Q_Z^{\otimes r} Q_{K_{j-1}} Q_{T_j} Q_{K_j} \|_1. \end{aligned} \quad (138)$$

From (133) and the monotonicity of KL-divergence the first term on the RHS of (138) goes to zero when r grows.

To bound the second term on the RHS of (138) for a fixed codebook C_r we have,

$$\Gamma_{M_j, T_{j-1}, K_{j-2}}^{(C_r)} = 2^{-r(R+R_t+R_k)} = \Upsilon_{M_j, T_{j-1}, K_{j-2}}^{(C_r)}, \quad (139a)$$

$$\Gamma_{L_j, A_j | M_j, T_{j-1}, K_{j-2}, S_j^r}^{(C_r)} = f^{LE}(\ell_j, a_j | s_j^r, m_j, t_{j-1}, k_{j-2}) = \Upsilon_{L_j, A_j | M_j, T_{j-1}, K_{j-2}, S_j^r}^{(C_r)}, \quad (139b)$$

$$\Gamma_{U^r|M_j, T_{j-1}, K_{j-2}, S_j^r, L_j, A_j}^{(C_r)} = \mathbb{1}_{\{\tilde{u}^r = u^r(m_j, t_{j-1}, k_{j-2}, \ell_j)\}} = \Upsilon_{U^r|M_j, T_{j-1}, K_{j-2}, S_j^r, L_j, A_j}^{(C_r)}, \quad (139c)$$

$$\Gamma_{V^r|M_j, T_{j-1}, K_{j-2}, S_j^r, L_j, A_j, U^r}^{(C_r)} = \mathbb{1}_{\{\tilde{v}^r = v^r(a_j)\}} = \Upsilon_{V^r|M_j, T_{j-1}, K_{j-2}, S_j^r, L_j, A_j, U^r}^{(C_r)} \quad (139d)$$

$$\Gamma_{Z_j^r|M_j, T_{j-1}, K_{j-2}, S_j^r, L_j, A_j, U^r, V^r}^{(C_r)} = W_{Z|U, S}^{\otimes r} = \Upsilon_{Z_j^r|M_j, T_{j-1}, K_{j-2}, S_j^r, L_j, A_j, U^r, V^r}^{(C_r)} \quad (139e)$$

$$\Gamma_{K_{j-1}|M_j, T_{j-1}, K_{j-2}, S_j^r, L_j, A_j, U^r, V^r, Z_j^r}^{(C_r)} = 2^{-rR_k} = \Upsilon_{K_{j-1}|M_j, T_{j-1}, K_{j-2}, S_j^r, L_j, A_j, U^r, V^r, Z_j^r}^{(C_r)} \quad (139f)$$

$$\Gamma_{T_j|M_j, T_{j-1}, K_{j-2}, S_j^r, L_j, A_j, U^r, V^r, Z_j^r, K_{j-1}}^{(C_r)} = \mathbb{1}_{\{t_j = \sigma(v^r)\}} = \Upsilon_{T_j|M_j, T_{j-1}, K_{j-2}, S_j^r, L_j, A_j, U^r, V^r, Z_j^r, K_{j-1}}^{(C_r)} \quad (139g)$$

$$\Gamma_{K_j|M_j, T_{j-1}, K_{j-2}, S_j^r, L_j, A_j, U^r, V^r, Z_j^r, K_{j-1}, T_j}^{(C_r)} = \mathbb{1}_{\{k_j = \Phi(v^r)\}} = \Upsilon_{K_j|M_j, T_{j-1}, K_{j-2}, S_j^r, L_j, A_j, U^r, V^r, Z_j^r, K_{j-1}, T_j}^{(C_r)} \quad (139h)$$

where (139b) follows from (131). Hence,

$$\begin{aligned} & \mathbb{E}_{C_r} \left\| \Upsilon_{Z_j^r, K_{j-1}, T_j, K_j | C_r} - \Gamma_{Z_j^r, K_{j-1}, T_j, K_j | C_r} \right\|_1 \\ & \leq \mathbb{E}_{C_r} \left\| \Upsilon_{M_j, T_{j-1}, K_{j-2}, S_j^r, L_j, A_j, U^r, V^r, Z_j^r, K_{j-1}, T_j, K_j | C_r} - \Gamma_{M_j, T_{j-1}, K_{j-2}, S_j^r, L_j, A_j, U^r, V^r, Z_j^r, K_{j-1}, T_j, K_j | C_r} \right\|_1 \\ & \stackrel{(a)}{=} \mathbb{E}_{C_r} \left\| \Upsilon_{M_j, T_{j-1}, K_{j-2}, S_j^r | C_r} - \Gamma_{M_j, T_{j-1}, K_{j-2}, S_j^r | C_r} \right\|_1 \\ & \stackrel{(b)}{=} \mathbb{E}_{C_r} \left\| Q_S^{\otimes r} - \Gamma_{S_j^r | M_j=1, T_{j-1}=1, K_{j-2}=1, C_r} \right\|_1, \end{aligned} \quad (140)$$

where (a) follows from (139b)-(139h) and (b) follows from the symmetry of the codebook construction with respect to M_j , T_{j-1} , and K_{j-2} and (139a). Based on [33, Theorem 2] the RHS of (140) vanishes if

$$R' > \mathbb{I}(U; S), \quad (141a)$$

$$\tilde{R} > \mathbb{I}(V; S), \quad (141b)$$

$$R' + \tilde{R} > \mathbb{I}(U, V; S). \quad (141c)$$

We now proceed to bound the third term on the RHS of (138). First, consider the marginal

$$\begin{aligned} \Gamma_{Z_j^r, K_{j-1}, T_j, K_j | C_r}(z_j^r, k_{j-1}, t_j, k_j) &= \sum_{m_j} \sum_{t_{j-1}} \sum_{k_{j-2}} \sum_{\ell_j} \sum_{a_j} \sum_{s_j^r} \frac{1}{2^{r(R+R_t+2R_k+R'+\tilde{R})}} \\ & \times P_{S|U, V}^{\otimes r}(s_j^r | U^r(m_j, t_{j-1}, k_{j-2}, \ell_j), V^r(a_j)) W_{Z|U, S}^{\otimes r}(z_j^r | U^r(m_j, t_{j-1}, k_{j-2}, \ell_j), s_j^r) \\ & \times \mathbb{1}_{\{t_j = \sigma(V^r(a_j))\}} \mathbb{1}_{\{k_j = \Phi(V^r(a_j))\}} \end{aligned} \quad (142)$$

$$\begin{aligned} &= \sum_{m_j} \sum_{t_{j-1}} \sum_{k_{j-2}} \sum_{\ell_j} \sum_{a_j} \frac{1}{2^{r(R+R_t+2R_k+R'+\tilde{R})}} W_{Z|U, V}^{\otimes r}(z_j^r | U^r(m_j, t_{j-1}, k_{j-2}, \ell_j), V^r(a_j)) \\ & \times \mathbb{1}_{\{t_j = \sigma(V^r(a_j))\}} \mathbb{1}_{\{k_j = \Phi(V^r(a_j))\}}, \end{aligned} \quad (143)$$

where $W_{Z|U, V}(z|u, v) = \sum_{s \in \mathcal{S}} P_{S|U, V}(s|u, v) W_{Z|U, S}(z|u, s)$. To bound the third term on the RHS of (138) by using Pinsker's inequality, it is sufficient to bound $\mathbb{E}_{C_r} [\mathbb{D}(\Gamma_{Z_j^r, K_{j-1}, T_j, K_j | C_r} \| Q_Z^{\otimes r} Q_{K_{j-1}} Q_{T_j} Q_{K_j})]$ as follows,

$$\begin{aligned} & \mathbb{E}_{C_r} [\mathbb{D}(\Gamma_{Z_j^r, K_{j-1}, T_j, K_j | C_r} \| Q_Z^{\otimes r} Q_{K_{j-1}} Q_{T_j} Q_{K_j})] \\ &= \mathbb{E}_{C_r} \left[\sum_{(z_j^r, k_{j-1}, t_j, k_j)} \Gamma_{Z_j^r, K_{j-1}, T_j, K_j | C_r}(z_j^r, k_{j-1}, t_j, k_j) \log \left(\frac{\Gamma_{Z_j^r, K_{j-1}, T_j, K_j | C_r}(z_j^r, k_{j-1}, t_j, k_j)}{Q_Z^{\otimes r}(z_j^r) Q_{K_{j-1}}(k_{j-1}) Q_{T_j}(t_j) Q_{K_j}(k_j)} \right) \right] \\ &= \mathbb{E}_{C_r} \left[\sum_{(z_j^r, k_{j-1}, t_j, k_j)} \sum_{m_j} \sum_{t_{j-1}} \sum_{k_{j-2}} \sum_{\ell_j} \sum_{a_j} \frac{1}{2^{r(R+R_t+2R_k+R'+\tilde{R})}} W_{Z|U, V}^{\otimes r}(z_j^r | U^r(m_j, t_{j-1}, k_{j-2}, \ell_j), V^r(a_j)) \right. \\ & \left. \times \mathbb{1}_{\{t_j = \sigma(V^r(a_j))\}} \mathbb{1}_{\{k_j = \Phi(V^r(a_j))\}} \right] \end{aligned}$$

$$\begin{aligned}
& \times \log \left(\frac{\sum_{\tilde{m}_j} \sum_{\tilde{t}_{j-1}} \sum_{\tilde{k}_{j-2}} \sum_{\tilde{\ell}_j} \sum_{\tilde{a}_j} W_{Z|U,V}^{\otimes r}(z_j^r | U^r(\tilde{m}_j, \tilde{t}_{j-1}, \tilde{k}_{j-2}, \tilde{\ell}_j), V^r(\tilde{a}_j)) \mathbb{1}_{\{t_j = \sigma(V^r(\tilde{a}_j))\}} \mathbb{1}_{\{k_j = \Phi(V^r(\tilde{a}_j))\}}}{2^{r(R+R_t+R_k+R'+\tilde{R}-R_T-R_K)} Q_Z^{\otimes r}(z_j^r)} \right) \\
& \stackrel{(a)}{\leq} \sum_{(z_j^r, k_{j-1}, t_j, k_j)} \sum_{m_j} \sum_{t_{j-1}} \sum_{k_{j-2}} \sum_{\ell_j} \sum_{a_j} \frac{1}{2^{r(R+R_t+2R_k+R'+\tilde{R})}} \sum_{(u^r, v^r)} \Gamma_{U^r, V^r, Z^r}^{(C_r)}(u^r(m_j, t_{j-1}, k_{j-2}, \ell_j), v^r(a_j), z_j^r) \\
& \times \mathbb{E}_{\sigma(v^r(a_j))} [\mathbb{1}_{\{t_j = \sigma(v^r(a_j))\}}] \times \mathbb{E}_{\Phi(v^r(a_j))} [\mathbb{1}_{\{k_j = \Phi(v^r(a_j))\}}] \\
& \times \log \mathbb{E}_{\setminus (m_j, t_{j-1}, k_{j-2}, \ell_j, a_j), (\sigma(v^r(a_j)), \Phi(v^r(a_j)))} \left[\frac{1}{2^{r(R+R_t+R_k+R'+\tilde{R}-R_T-R_K)} Q_Z^{\otimes r}(z_j^r)} \right. \\
& \times \left. \sum_{\tilde{m}_j} \sum_{\tilde{t}_{j-1}} \sum_{\tilde{k}_{j-2}} \sum_{\tilde{\ell}_j} \sum_{\tilde{a}_j} W_{Z|U,V}^{\otimes r}(z_j^r | U^r(\tilde{m}_j, \tilde{t}_{j-1}, \tilde{k}_{j-2}, \tilde{\ell}_j), V^r(\tilde{a}_j)) \mathbb{1}_{\{t_j = \sigma(V^r(\tilde{a}_j))\}} \mathbb{1}_{\{k_j = \Phi(V^r(\tilde{a}_j))\}} \right] \\
& \stackrel{(b)}{\leq} \sum_{(z_j^r, k_{j-1}, t_j, k_j)} \sum_{m_j} \sum_{t_{j-1}} \sum_{k_{j-2}} \sum_{\ell_j} \sum_{a_j} \frac{1}{2^{r(R+R_t+2R_k+R'+\tilde{R}+R_T+R_K)}} \sum_{(u^r, v^r)} \Gamma_{U^r, V^r, Z^r}^{(C_r)}(u^r(m_j, t_{j-1}, k_{j-2}, \ell_j), v^r(a_j), z_j^r) \\
& \times \log \frac{1}{2^{r(R+R_t+R_k+R'+\tilde{R}-R_T-R_K)} Q_Z^{\otimes r}(z_j^r)} \left(W_{Z|U,V}^{\otimes r}(z_j^r | u^r(m_j, t_{j-1}, k_{j-2}, \ell_j), v^r(a_j)) \right. \\
& + \mathbb{E}_{\setminus (m_j, t_{j-1}, k_{j-2}, \ell_j)} \left[\sum_{(\tilde{m}_j, \tilde{t}_{j-1}, \tilde{k}_{j-2}, \tilde{\ell}_j) \neq (m_j, t_{j-1}, k_{j-2}, \ell_j)} W_{Z|U,V}^{\otimes r}(z_j^r | U^r(\tilde{m}_j, \tilde{t}_{j-1}, \tilde{k}_{j-2}, \tilde{\ell}_j), v^r(a_j)) \right] \\
& + \mathbb{E}_{\setminus (a_j, \sigma(v^r(a_j)), \Phi(v^r(a_j)))} \left[\sum_{\tilde{a}_j \neq a_j} W_{Z|U,V}^{\otimes r}(z_j^r | u^r(m_j, t_{j-1}, k_{j-2}, \ell_j), V^r(\tilde{a}_j)) \mathbb{1}_{\{t_j = \sigma(V^r(\tilde{a}_j))\}} \mathbb{1}_{\{k_j = \Phi(V^r(\tilde{a}_j))\}} \right] \\
& + \mathbb{E}_{\setminus (m_j, t_{j-1}, k_{j-2}, \ell_j, a_j), (\sigma(v^r(a_j)), \Phi(v^r(a_j)))} \left[\sum_{(\tilde{m}_j, \tilde{t}_{j-1}, \tilde{k}_{j-2}, \tilde{\ell}_j) \neq (m_j, t_{j-1}, k_{j-2}, \ell_j)} \sum_{\tilde{a}_j \neq a_j} W_{Z|U,V}^{\otimes r}(z_j^r | U^r(\tilde{m}_j, \tilde{t}_{j-1}, \tilde{k}_{j-2}, \tilde{\ell}_j), V^r(\tilde{a}_j)) \right. \\
& \left. \times \mathbb{1}_{\{t_j = \sigma(V^r(\tilde{a}_j))\}} \mathbb{1}_{\{k_j = \Phi(V^r(\tilde{a}_j))\}} \right] \Big) \\
& \stackrel{(c)}{\leq} \sum_{(z_j^r, k_{j-1}, t_j, k_j)} \sum_{m_j} \sum_{t_{j-1}} \sum_{k_{j-2}} \sum_{\ell_j} \sum_{a_j} \frac{1}{2^{r(R+R_t+2R_k+R'+\tilde{R}+R_T+R_K)}} \sum_{(u^r, v^r)} \Gamma_{U^r, V^r, Z^r}^{(C_r)}(u^r(m_j, t_{j-1}, k_{j-2}, \ell_j), v^r(a_j), z_j^r) \\
& \times \log \left(\frac{W_{Z|U,V}^{\otimes r}(z_j^r | u^r(m_j, t_{j-1}, k_{j-2}, \ell_j), v^r(a_j))}{2^{r(R+R_t+R_k+R'+\tilde{R}-R_T-R_K)} Q_Z^{\otimes r}(z_j^r)} \right. \\
& + \sum_{(\tilde{m}_j, \tilde{t}_{j-1}, \tilde{k}_{j-2}, \tilde{\ell}_j) \neq (m_j, t_{j-1}, k_{j-2}, \ell_j)} \frac{W_{Z|V}^{\otimes r}(z_j^r | v^r(a_j))}{2^{r(R+R_t+R_k+R'+\tilde{R}-R_T-R_K)} Q_Z^{\otimes r}(z_j^r)} + \sum_{\tilde{a}_j \neq a_j} \frac{W_{Z|U}^{\otimes r}(z_j^r | u^r(m_j, t_{j-1}, k_{j-2}, \ell_j))}{2^{r(R+R_t+R_k+R'+\tilde{R})} Q_Z^{\otimes r}(z_j^r)} + 1 \Big) \\
& \leq \sum_{(z_j^r, k_{j-1}, t_j, k_j)} \sum_{m_j} \sum_{t_{j-1}} \sum_{k_{j-2}} \sum_{\ell_j} \sum_{a_j} \frac{1}{2^{r(R+R_t+2R_k+R'+\tilde{R}+R_T+R_K)}} \sum_{(u^r, v^r)} \Gamma_{U^r, V^r, Z^r}^{(C_r)}(u^r(m_j, t_{j-1}, k_{j-2}, \ell_j), v^r(a_j), z_j^r) \\
& \times \log \left(\frac{W_{Z|U,V}^{\otimes r}(z_j^r | u^r(m_j, t_{j-1}, k_{j-2}, \ell_j), v^r(a_j))}{2^{r(R+R_t+R_k+R'+\tilde{R}-R_T-R_K)} Q_Z^{\otimes r}(z_j^r)} + \frac{W_{Z|V}^{\otimes r}(z_j^r | v^r(a_j))}{2^{r(\tilde{R}-R_T-R_K)} Q_Z^{\otimes r}(z_j^r)} + \frac{W_{Z|U}^{\otimes r}(z_j^r | u^r(m_j, t_{j-1}, k_{j-2}, \ell_j))}{2^{r(R+R_t+R_k+R')} Q_Z^{\otimes r}(z_j^r)} + 1 \right) \\
& \triangleq \Psi_1 + \Psi_2, \tag{144}
\end{aligned}$$

where (a) follows from Jensen's inequality, (b) and (c) hold because $\mathbb{1}_{\{\cdot\}} \leq 1$. We defined Ψ_1 and Ψ_2 as

$$\Psi_1 = \sum_{(k_{j-1}, t_j, k_j)} \sum_{m_j} \sum_{t_{j-1}} \sum_{k_{j-2}} \sum_{\ell_j} \sum_{a_j} \frac{1}{2^{r(R+R_t+2R_k+R'+\tilde{R}+R_T+R_K)}}$$

$$\begin{aligned}
& \times \sum_{(u^r(m_j, t_{j-1}, k_{j-2}, \ell_j), v^r(a_j), z_j^r) \in \mathcal{T}_\epsilon^{(n)}} \Gamma_{U^r, V^r, Z^r}^{(C_r)}(u^r(m_j, t_{j-1}, k_{j-2}, \ell_j), v^r(a_j), z_j^r) \\
& \times \log \left(\frac{W_{Z|U, V}^{\otimes r}(z_j^r | u^r(m_j, t_{j-1}, k_{j-2}, \ell_j), v^r(a_j))}{2^{r(R+R_t+R_k+R'+\tilde{R}-R_T-R_K)} Q_Z^{\otimes r}(z_j^r)} + \frac{W_{Z|V}^{\otimes r}(z_j^r | v^r(a_j))}{2^{r(\tilde{R}-R_T-R_K)} Q_Z^{\otimes r}(z_j^r)} + \frac{W_{Z|U}^{\otimes r}(z_j^r | u^r(m_j, t_{j-1}, k_{j-2}, \ell_j))}{2^{r(R+R_t+R_k+R')} Q_Z^{\otimes r}(z_j^r)} + 1 \right) \\
& \leq \log \left(\frac{2^{r(R_T+R_K)} \times 2^{-r(1-\epsilon)\mathbb{H}(Z|U, V)}}{2^{r(R+R_t+R_k+R'+\tilde{R})} \times 2^{-r(1+\epsilon)\mathbb{H}(Z)}} + \frac{2^{r(R_T+R_K)} \times 2^{-r(1-\epsilon)\mathbb{H}(Z|V)}}{2^{r\tilde{R}} \times 2^{-r(1+\epsilon)\mathbb{H}(Z)}} + \frac{2^{-r(1-\epsilon)\mathbb{H}(Z|U)}}{2^{r(R+R_t+R_k+R')} \times 2^{-r(1+\epsilon)\mathbb{H}(Z)}} + 1 \right)
\end{aligned} \tag{145}$$

$$\begin{aligned}
\Psi_2 &= \sum_{(k_{j-1}, t_j, k_j)} \sum_{m_j} \sum_{t_{j-1}} \sum_{k_{j-2}} \sum_{\ell_j} \sum_{a_j} \frac{1}{2^{r(R+R_t+2R_k+R'+\tilde{R}+R_T+R_K)}} \\
& \times \sum_{(u^r(m_j, t_{j-1}, k_{j-2}, \ell_j), v^r(a_j), z_j^r) \notin \mathcal{T}_\epsilon^{(n)}} \Gamma_{U^r, V^r, Z^r}^{(C_r)}(u^r(m_j, t_{j-1}, k_{j-2}, \ell_j), v^r(a_j), z_j^r) \\
& \times \log \left(\frac{W_{Z|U, V}^{\otimes r}(z_j^r | u^r(m_j, t_{j-1}, k_{j-2}, \ell_j), v^r(a_j))}{2^{r(R+R_t+R_k+R'+\tilde{R}-R_T-R_K)} Q_Z^{\otimes r}(z_j^r)} + \frac{W_{Z|V}^{\otimes r}(z_j^r | v^r(a_j))}{2^{r(\tilde{R}-R_T-R_K)} Q_Z^{\otimes r}(z_j^r)} + \frac{W_{Z|U}^{\otimes r}(z_j^r | u^r(m_j, t_{j-1}, k_{j-2}, \ell_j))}{2^{r(R+R_t+R_k+R')} Q_Z^{\otimes r}(z_j^r)} + 1 \right) \\
& \leq 2|V||U||Z|e^{-r\epsilon^2\mu_{S, V, U, Z}} r \log \left(\frac{3}{\mu_Z} + 1 \right).
\end{aligned} \tag{146}$$

In (146) $\mu_{V, U, Z} = \min_{(v, u, z) \in (\mathcal{V}, \mathcal{U}, \mathcal{Z})} P_{V, U, Z}(v, u, z)$ and $\mu_Z = \min_{z \in \mathcal{Z}} P_Z(z)$. When $r \rightarrow \infty$ then $\Psi_2 \rightarrow 0$ and Ψ_1 goes to zero when r grows if

$$R + R_t + R_k + R' + \tilde{R} - R_T - R_K > \mathbb{I}(U, V; Z), \tag{147a}$$

$$\tilde{R} - R_T - R_K > \mathbb{I}(V; Z), \tag{147b}$$

$$R + R_t + R_k + R' > \mathbb{I}(U; Z). \tag{147c}$$

Decoding and Error Probability Analysis: At the end of block $j \in \llbracket 1 : B \rrbracket$, using its knowledge of the key k_{j-2} generated from the block $j - 2$, the receiver finds a unique triple $(\hat{m}_j, \hat{t}_{j-1}, \hat{\ell}_j)$ such that $(u^r(\hat{m}_j, \hat{t}_{j-1}, k_{j-2}, \hat{\ell}_j), y_j^r) \in \mathcal{T}_\epsilon^{(r)}$. To bound the probability of error at the encoder and the decoder we need the following lemma,

Lemma 2 (Typical With High Probability). *If $(R', \tilde{R}) \in \mathbb{R}_+^2$ satisfies (141a) to (141c), then for any $(m_j, t_{j-1}, k_{j-2}) \in (\mathcal{M}_j, \mathcal{T}_{j-1}, \mathcal{K}_{j-2})$ and $\epsilon > 0$, we have*

$$\mathbb{E}_{C_r} \mathbb{P}_P \left((U^r(m_j, t_{j-1}, k_{j-2}, L_j), V^r(A_j), S_j^r) \notin \mathcal{T}_\epsilon^{(n)} | C_r \right) \xrightarrow[r \rightarrow \infty]{} 0, \tag{148}$$

where P is the induced distribution over the codebook defined in (133). The proof of Lemma 2 is given in Appendix E.

To analyze the probability of error we define the following error events for $j \in \llbracket 1 : B \rrbracket$,

$$\mathcal{E} \triangleq \{M \neq \hat{M}\}, \tag{149a}$$

$$\mathcal{E}_j \triangleq \{M_j \neq \hat{M}_j\}, \tag{149b}$$

$$\mathcal{E}_{1,j} \triangleq \{(U^r(M_j, T_{j-1}, K_{j-2}, L_j), S_j^r) \notin \mathcal{T}_{\epsilon_1}^{(n)}(U, S)\}, \tag{149c}$$

$$\mathcal{E}_{2,j} \triangleq \{(U^r(M_j, T_{j-1}, K_{j-2}, L_j), Y_j^r) \notin \mathcal{T}_{\epsilon_2}^{(n)}(U, Y)\}, \tag{149d}$$

$$\mathcal{E}_{3,j} \triangleq \{(U^r(M_j, T_{j-1}, K_{j-2}, L_j), Y_j^r) \in \mathcal{T}_{\epsilon_2}^{(n)}(U, Y) \text{ for some } m_j \neq M_j \text{ and } \ell_j \in [1 : 2^{rR'}]\}. \tag{149e}$$

where $\epsilon_2 > \epsilon_1 > \epsilon > 0$. The probability of error is upper bounded as follows,

$$\mathbb{P}(\mathcal{E}) = \mathbb{P}\left\{\bigcup_{j=1}^B \mathcal{E}_j\right\} \leq \sum_{j=1}^B \mathbb{P}(\mathcal{E}_j). \quad (150)$$

Now we bound $\mathbb{P}(\mathcal{E}_j)$ by using union bound,

$$\mathbb{P}(\mathcal{E}_j) \leq \mathbb{P}(\mathcal{E}_{1,j}) + \mathbb{P}(\mathcal{E}_{1,j}^c \cap \mathcal{E}_{2,j}) + \mathbb{P}(\mathcal{E}_{2,j}^c \cap \mathcal{E}_{3,j}). \quad (151)$$

According to Lemma 2 the first term on the RHS of (151) vanishes when r grows, and by the law of large numbers the second term on the RHS of (151) vanishes when r grows. Also, according to the law of large numbers and the packing lemma, the last term on the RHS of (151) vanishes when r grows if [31],

$$R + R_t + R' \leq \mathbb{I}(U; Y). \quad (152)$$

We now analyze the probability of error at the encoder and the decoder for key generation. Let (A_{j-1}, T_{j-1}) denote the chosen indices at the encoder and \hat{A}_{j-1} and \hat{T}_{j-1} be the estimates of the indices A_{j-1} and T_{j-1} at the decoder. At the end of block j , by decoding U_j^r , the decoder has access to \hat{T}_{j-1} . To find A_{j-1} we define the error event,

$$\mathcal{E}' = \left\{ \left(V_{j-1}^r(\hat{A}_{j-1}), S_{j-1}^r, U_{j-1}^r, Y_{j-1}^r \right) \notin \mathcal{T}_\epsilon^{(n)} \right\}, \quad (153)$$

and consider the events,

$$\mathcal{E}'_1 = \left\{ \left(V_{j-1}^r(a_{j-1}), S_{j-1}^r \right) \notin \mathcal{T}_{\epsilon'}^{(n)} \text{ for all } a_{j-1} \in \llbracket 1 : 2^{r\tilde{R}} \rrbracket \right\}, \quad (154a)$$

$$\mathcal{E}'_2 = \left\{ \left(V_{j-1}^r(A_{j-1}), S_{j-1}^r, U_{j-1}^r, Y_{j-1}^r \right) \notin \mathcal{T}_\epsilon^{(n)} \right\}, \quad (154b)$$

$$\mathcal{E}'_3 = \left\{ \left(V_{j-1}^r(\tilde{a}_{j-1}), U_{j-1}^r, Y_{j-1}^r \right) \in \mathcal{T}_\epsilon^{(n)} \text{ for some } \tilde{a}_{j-1} \in \mathcal{B}(\hat{T}_{j-1}), \tilde{a}_{j-1} \neq A_{j-1} \right\}, \quad (154c)$$

where $\epsilon > \epsilon' > 0$. By the union bound we have,

$$P(\mathcal{E}') \leq P(\mathcal{E}'_1) + P(\mathcal{E}'_1^c \cap \mathcal{E}'_2) + P(\mathcal{E}'_3). \quad (155)$$

According to Lemma 2 the first term on the RHS of (155) vanishes when r grows if we have (141). Following the steps in [31, Sec. 11.3.1], the last two terms on the right hand side of (155) go to zero when r grows if,

$$\tilde{R} > \mathbb{I}(V; S), \quad (156a)$$

$$\tilde{R} - R_t < \mathbb{I}(V; U, Y). \quad (156b)$$

The region in Theorem 4 is derived by remarking that the scheme requires $R_K + R_T \geq R_k + R_t$ and applying Fourier-Motzkin to (141) and (147), (152), and (156).

APPENDIX E

PROOF OF LEMMA 2

For a fix $\epsilon > 0$ consider the PMF Γ defined in (129). With respect to the random experiment described by Γ we have

$$\mathbb{E}_{C_r} \mathbb{P}_\Gamma \left(\left(U^r(m_j, t_{j-1}, k_{j-2}, L_j), V^r(A_j), S_j^r \right) \notin \mathcal{T}_\epsilon^{(n)} \mid C_r \right) \xrightarrow{r \rightarrow \infty} 0, \quad (157)$$

since $U^r(m_j, t_{j-1}, k_{j-2}, L_j) \sim P_U^r$ and $V^r(A_j) \sim P_V^r$ for every $(m_j, t_{j-1}, k_{j-2}) \in (\mathcal{M}_j, \mathcal{T}_{j-1}, \mathcal{K}_{j-2})$ and S_j^r is derived by passing $(U^r(m_j, t_{j-1}, k_{j-2}, L_j), V^r(A_j))$ through the DMC $P_{S|U,V}^{\otimes r}$. Therefore (157) holds by weak law of large numbers. We also have

$$\begin{aligned} & \mathbb{E}_{C_r} \|P_{U^r, V^r, S_j^r|C_r} - \Gamma_{U^r, V^r, S_j^r|C_r}\|_1 \\ & \leq \mathbb{E}_{C_r} \|P_{M_j, T_{j-1}, K_{j-2}, S_j^r, L_j, A_j, U^r, V^r, Z_j^r, K_{j-1}, T_j, K_j|C_r} - \Gamma_{M_j, T_{j-1}, K_{j-2}, S_j^r, L_j, A_j, U^r, V^r, Z_j^r, K_{j-1}, T_j, K_j|C_r}\|_1 \xrightarrow{r \rightarrow \infty} 0, \end{aligned} \quad (158)$$

where the RHS of (158) vanishes when r grows because of (140).

We now define $g_n : \mathcal{U}^r \times \mathcal{V}^r \times \mathcal{S}_j^r \rightarrow \mathbb{R}$ as $g_n(u^r, v^r, s_j^r) \triangleq \mathbb{1}_{\{(u^r, v^r, s_j^r) \notin \mathcal{T}_\epsilon^{(n)}\}}$. We now have

$$\begin{aligned} & \mathbb{E}_{C_r} \mathbb{P}_P \left((U^r(m_j, t_{j-1}, k_{j-2}, L_j), V^r(A_j), S_j^r) \notin \mathcal{T}_\epsilon^{(n)} | C_r \right) \\ & = \mathbb{E}_{C_r} \mathbb{E}_P \left[g_n(U^r(m_j, t_{j-1}, k_{j-2}, L_j), V^r(A_j), S_j^r) | C_r \right] \\ & \leq \mathbb{E}_{C_r} \mathbb{E}_\Gamma \left[g_n(U^r(m_j, t_{j-1}, k_{j-2}, L_j), V^r(A_j), S_j^r) | C_r \right] \\ & + \mathbb{E}_{C_r} \left| \mathbb{E}_P \left[g_n(U^r(m_j, t_{j-1}, k_{j-2}, L_j), V^r(A_j), S_j^r) | C_r \right] - \mathbb{E}_\Gamma \left[g_n(U^r(m_j, t_{j-1}, k_{j-2}, L_j), V^r(A_j), S_j^r) | C_r \right] \right| \\ & \stackrel{(a)}{\leq} \mathbb{E}_{C_r} \mathbb{E}_\Gamma \left[g_n(U^r(m_j, t_{j-1}, k_{j-2}, L_j), V^r(A_j), S_j^r) | C_r \right] + \mathbb{E}_{C_r} \|P_{U^r, V^r, S_j^r|C_r} - \Gamma_{U^r, V^r, S_j^r|C_r}\|_1 \end{aligned} \quad (159)$$

where (a) follows from [34, Property 1] for g_n being bounded by 1. From (157) and (158) the RHS of (159) vanishes when r grows.

APPENDIX F PROOF OF THEOREM 5

Fix $P_{U|S}(u|s)$, $x(u, s)$, and $\epsilon_1 > \epsilon_2 > 0$ such that, $P_Z = Q_0$.

Codebook Generation: Let $C_n \triangleq \{U^n(m, \ell)\}_{(m, \ell) \in \mathcal{M} \times \mathcal{L}}$, where $\mathcal{M} \in [1 : 2^{nR}]$ and $\mathcal{L} \in [1 : 2^{nR'}]$, be a random codebook consisting of independent random sequences each generated according to $\prod_{i=1}^n P_U(u_i)$. We denote a realization of C_n by $\mathcal{C}_n \triangleq \{u^n(m, \ell)\}_{(m, \ell) \in \mathcal{M} \times \mathcal{L}}$. We define an ideal PMF for codebook \mathcal{C}_n , as an approximate distribution to facilitate the analysis

$$\Gamma_{M, L, U^n, S^n, Z^n}^{(\mathcal{C}_n)}(m, \ell, \tilde{u}^n, s^n, z^n) = 2^{-n(R+R')} \mathbb{1}_{\{\tilde{u}^n = u^n(m, \ell)\}} P_{S|U}^{\otimes n}(s^n | \tilde{u}^n) W_{Z|U, S}^{\otimes n}(z^n | \tilde{u}^n, s^n), \quad (160)$$

where $W_{Z|U, S}$ is the marginal distribution $W_{Z|U, S} = \sum_{x \in \mathcal{X}} \mathbb{1}_{\{x = x(u, s)\}} W_{Z|X, S}$ and $P_{S|U}$ is defined as follows,

$$P_{S|U}(s|u) \triangleq \frac{P_{S,U}(s, u)}{P_U(u)} = \frac{Q_S(s) P_{U|S}(u|s)}{\sum_{s \in \mathcal{S}} Q_S(s) P_{U|S}(u|s)}. \quad (161)$$

Encoding: To send the message m the encoder chooses ℓ according to

$$f(\ell | s^n, m) = \frac{P_{S|U}^{\otimes n}(s^n | u^n(m, \ell))}{\sum_{\ell' \in [1 : 2^{nR'}]} P_{S|U}^{\otimes n}(s^n | u^n(m, \ell'))}, \quad (162)$$

where $P_{S|U}$ is defined in (161). Based on (m, ℓ) the encoder computes $u^n(m, \ell)$ and transmits codeword x^n , where $x_i = x(u_i(m, \ell), s_i)$.

For a fixed codebook \mathcal{C}_n , the induced joint distribution over the codebook is as follows

$$P_{M, S^n, L, U^n, Z^n}^{(\mathcal{C}_n)}(m, s^n, \ell, \tilde{u}^n, z^n) = 2^{-nR} Q_S^{\otimes n}(s^n) f(\ell | s^n, m) \mathbb{1}_{\{\tilde{u}^n = u^n(m, \ell)\}} W_{Z|U, S}^{\otimes n}(z^n | \tilde{u}^n, s^n). \quad (163)$$

Covert Analysis: We now show that this coding scheme guarantees that

$$\mathbb{E}_{C_n} [\mathbb{D}(P_{Z^n|C_n} \| Q_Z^{\otimes n})] \xrightarrow{n \rightarrow \infty} 0. \quad (164)$$

Then we choose $P_{U|S}$ and $x(u, s)$ such that it satisfies $Q_Z = Q_0$. By Combining Lemma 1 and the triangle inequality a sufficient condition for (164) is to show that the RHS of the following inequality vanishes,

$$\mathbb{E}_{C_n} \|P_{Z^n|C_n} - Q_Z^{\otimes n}\|_1 \leq \mathbb{E}_{C_n} \|P_{Z^n|C_n} - \Gamma_{Z^n|C_n}\|_1 + \mathbb{E}_{C_n} \|\Gamma_{Z^n|C_n} - Q_Z^{\otimes n}\|_1. \quad (165)$$

By [26, Corollary VII.5] the second term on the RHS of (165) vanishes when n grows if

$$R + R' > \mathbb{I}(U; Z). \quad (166)$$

To bound the first term on the RHS of (165) we have,

$$\Gamma_M^{(C_n)} = 2^{-nR} = P_M^{(C_n)}, \quad (167a)$$

$$\Gamma_{L|M, S^n}^{(C_n)} = f(\ell|s^n, m) = P_{L|M, S^n}^{(C_n)}, \quad (167b)$$

$$\Gamma_{U^n|M, S^n, L}^{(C_n)} = \mathbb{1}_{\{\bar{u}^n = u^n(m, \ell)\}} = P_{U^n|M, S^n, L}^{(C_n)}, \quad (167c)$$

$$\Gamma_{Z^n|M, S^n, L, U^n}^{(C_n)} = W_{Z|U, S}^{\otimes n} = P_{Z^n|M, S^n, L, U^n}^{(C_n)}, \quad (167d)$$

where (167b) follows from (162). Hence,

$$\begin{aligned} \mathbb{E}_{C_n} \|P_{Z^n|C_n} - \Gamma_{Z^n|C_n}\|_1 &\leq \mathbb{E}_{C_n} \|P_{M, S^n, L, U^n, Z^n|C_n} - \Gamma_{M, S^n, L, U^n, Z^n|C_n}\|_1 \\ &\stackrel{(a)}{=} \mathbb{E}_{C_n} \|P_{S^n, L, U^n, Z^n|M=1, C_n} - \Gamma_{S^n, L, U^n, Z^n|M=1, C_n}\|_1 \\ &\stackrel{(b)}{=} \mathbb{E}_{C_n} \|Q_S^{\otimes n} - \Gamma_{S^n|M=1, C_n}\|_1, \end{aligned} \quad (168)$$

where (a) follows from (167b)-(167d) and (b) follows from the symmetry of the codebook construction with respect to M and (167a). Based on the soft covering lemma [26, Corollary VII.5] the RHS of (168) vanishes if

$$R' > \mathbb{I}(U; S). \quad (169)$$

Decoding and Error Probability Analysis: To decode the message m , the receiver finds a unique pair $(\hat{m}, \hat{\ell})$ such that $(u^r(\hat{m}, \hat{\ell}), y^r) \in \mathcal{T}_\epsilon^{(r)}$. To analyze the probability of error we define the following error events,

$$\mathcal{E} \triangleq \{M \neq \hat{M}\}, \quad (170a)$$

$$\mathcal{E}_1 \triangleq \{(U^r(M, L), S^r) \notin \mathcal{T}_{\epsilon_1}^{(n)}(U, S)\}, \quad (170b)$$

$$\mathcal{E}_2 \triangleq \{(U^r(M, L), Y^r) \notin \mathcal{T}_{\epsilon_2}^{(n)}(U, Y)\}, \quad (170c)$$

$$\mathcal{E}_3 \triangleq \{(U^r(M, L), Y^r) \in \mathcal{T}_{\epsilon_2}^{(n)}(U, Y) \text{ for some } m \neq M \text{ and } \ell \in [1 : 2^{rR'}]\}, \quad (170d)$$

where $\epsilon_2 > \epsilon_1 > 0$. Now we bound $\mathbb{P}(\mathcal{E})$ by using union bound,

$$\mathbb{P}(\mathcal{E}) \leq \mathbb{P}(\mathcal{E}_1) + \mathbb{P}(\mathcal{E}_1^c \cap \mathcal{E}_2) + \mathbb{P}(\mathcal{E}_2^c \cap \mathcal{E}_3). \quad (171)$$

Similar to Lemma 2 one can show that the first term on the RHS of (171) vanishes when r grows, and by the law of large numbers the second term on the RHS of (171) vanishes when r grows. Also, according to the law of large numbers and the packing lemma, the last term on the RHS of (171) vanishes when r grows if [31],

$$R + R' \leq \mathbb{I}(U; Y). \quad (172)$$

The region in Theorem 5 is derived by applying Fourier-Motzkin to (166), (169), and (172).

APPENDIX G
PROOF OF THEOREM 6

Consider any sequence of length- n codes for a state-dependent channel with channel state available non-causally only at the transmitter such that $P_e^{(n)} \leq \epsilon_n$ and $\mathbb{D}(P_{Z^n} || Q_0^{\otimes n}) \leq \delta$ with $\lim_{n \rightarrow \infty} \epsilon_n = 0$. Note that the converse is consistent with the model and does *not* require δ to vanish. The following lemma, a version of which with variational distance can be found in [26, Lemma VI.3], will prove useful.

Lemma 3. *If $\mathbb{D}(P_{Z^n} || Q_0^{\otimes n}) \leq \delta$, then $\sum_{i=1}^n \mathbb{I}(Z_i; Z^{i-1}) \leq \delta$ and $\sum_{i=1}^n \mathbb{I}(Z_i; Z_{i+1}^n) \leq \delta$. In addition if $T \in \llbracket 1:n \rrbracket$ is an independent variable uniformly distributed, then $\mathbb{I}(T; Z_T) \leq \nu$, where $\nu \triangleq \frac{\delta}{n}$.*

Note that Lemma 3 is slightly different from [26, Lemma VI.3], as the upper bounds are tighter and do not include a factor of n . This is a consequence of using a constraint based on relative entropy instead of total variation. This is crucial in what follows as we do not necessarily require $\delta \rightarrow 0$. The details of the proof are available in Appendix H.

A. Epsilon Rate Region

We first define a region \mathcal{S}_ϵ for $\epsilon > 0$ that expands the region defined in (29a) and (29b) as follows.

$$\mathcal{S}_\epsilon \triangleq \{R \geq 0 : \exists P_{U,V,S,X,Y,Z} \in \mathcal{D}_\epsilon : R \leq \min\{\mathbb{I}(U; Y) - \mathbb{I}(U; S), \mathbb{I}(U, V; Y) - \mathbb{I}(U; S|V)\} + \epsilon\} \quad (173a)$$

where

$$\mathcal{D}_\epsilon = \left\{ \begin{array}{l} P_{U,V,S,X,Y,Z} : \\ P_{U,V,S,X,Y,Z} = Q_S P_{UV|S} \mathbb{1}_{\{X=X(U,S)\}} W_{Y,Z|X,S} \\ \mathbb{D}(P_Z || Q_0) \leq \epsilon \\ \min\{\mathbb{I}(U; Y) - \mathbb{I}(U; S), \mathbb{I}(U, V; Y) - \mathbb{I}(U; S|V)\} \geq \mathbb{I}(V; Z) - \mathbb{I}(V; S) - 3\epsilon \\ \max\{|\mathcal{U}|, |\mathcal{V}|\} \leq |\mathcal{X}| + 3 \end{array} \right\}, \quad (173b)$$

where $\epsilon \triangleq \max\{\epsilon_n, \nu \geq \frac{\delta}{n}\}$. We next show that if a rate R is achievable then $R \in \mathcal{S}_\epsilon$ for any $\epsilon > 0$.

For any $\epsilon_n > 0$, we start by upper bounding nR using standard techniques.

$$\begin{aligned} nR &= \mathbb{H}(M) \\ &\stackrel{(a)}{\leq} \mathbb{I}(M; Y^n) + n\epsilon_n \\ &= \sum_{i=1}^n \mathbb{I}(M; Y_i | Y^{i-1}) + n\epsilon_n \\ &\leq \sum_{i=1}^n \mathbb{I}(M, Y^{i-1}; Y_i) + n\epsilon_n \\ &= \sum_{i=1}^n [\mathbb{I}(M, Y^{i-1}, S_{i+1}^n; Y_i) - \mathbb{I}(S_{i+1}^n; Y_i | M, Y^{i-1})] + n\epsilon_n \\ &\stackrel{(b)}{=} \sum_{i=1}^n [\mathbb{I}(M, Y^{i-1}, S_{i+1}^n; Y_i) - \mathbb{I}(Y^{i-1}; S_i | M, S_{i+1}^n)] + n\epsilon_n \\ &\stackrel{(c)}{=} \sum_{i=1}^n [\mathbb{I}(M, Y^{i-1}, S_{i+1}^n; Y_i) - \mathbb{I}(M, Y^{i-1}, S_{i+1}^n; S_i)] + n\epsilon_n \end{aligned}$$

$$\begin{aligned}
& \stackrel{(d)}{=} \sum_{i=1}^n [\mathbb{I}(U_i; Y_i) - \mathbb{I}(U_i; S_i)] + n\epsilon_n \\
& = n \sum_{i=1}^n \frac{1}{n} [\mathbb{I}(U_i; Y_i|T=i) - \mathbb{I}(U_i; S_i|T=i)] + n\epsilon_n \\
& = n \sum_{i=1}^n \mathbb{P}(T=i) [\mathbb{I}(U_i; Y_i|T=i) - \mathbb{I}(U_i; S_i|T=i)] + n\epsilon_n \\
& = n [\mathbb{I}(U_T; Y_T|T) - \mathbb{I}(U_T; S_T|T)] + n\epsilon_n \\
& \stackrel{(e)}{=} n [\mathbb{I}(U_T; Y_T|T) - \mathbb{I}(U_T, T; S_T)] + n\epsilon_n \\
& \leq [\mathbb{I}(U_T, T; Y_T) - \mathbb{I}(U_T, T; S_T)] + n\epsilon_n \\
& \stackrel{(f)}{=} n [\mathbb{I}(U; Y) - \mathbb{I}(U; S)] + n\epsilon_n \\
& \stackrel{(g)}{\leq} n [\mathbb{I}(U; Y) - \mathbb{I}(U; S)] + n\epsilon \tag{174}
\end{aligned}$$

where

- (a) follows from Fano's inequality for n large enough and the fact that conditioning does not increase entropy;
- (b) follows from Csiszár-Körner sum identity [35, Lemma 7];
- (c) follows since S_i is independent of (M, S_{i+1}^n) ;
- (d) follows by defining $U_i \triangleq (M, Y^{i-1}, S_{i+1}^n)$;
- (e) follows from the independence of S_T and T ;
- (f) follows by defining $U = (U_T, T)$, $Y = Y_T$, and $S = S_T$;
- (g) follows by defining $\epsilon \triangleq \max\{\epsilon_n, \nu \geq \frac{\delta}{n}\}$.

We also have,

$$\begin{aligned}
nR &= \mathbb{H}(M) \\
& \stackrel{(a)}{\leq} \mathbb{I}(M; Y^n) + n\epsilon_n \\
& = \sum_{i=1}^n \mathbb{I}(M; Y_i|Y^{i-1}) + n\epsilon_n \\
& \leq \sum_{i=1}^n \mathbb{I}(M, Y^{i-1}, Z^{i-1}; Y_i) + n\epsilon_n \\
& = \sum_{i=1}^n [\mathbb{I}(M, Y^{i-1}, Z^{i-1}, S_{i+1}^n; Y_i) - \mathbb{I}(S_{i+1}^n; Y_i|M, Y^{i-1}, Z^{i-1})] + n\epsilon_n \\
& \stackrel{(b)}{=} \sum_{i=1}^n [\mathbb{I}(M, Y^{i-1}, Z^{i-1}, S_{i+1}^n; Y_i) - \mathbb{I}(Y^{i-1}; S_i|M, S_{i+1}^n, Z^{i-1})] + n\epsilon_n \\
& \stackrel{(c)}{=} \sum_{i=1}^n [\mathbb{I}(U_i, V_i; Y_i) - \mathbb{I}(U_i; S_i|V_i)] + n\epsilon_n \\
& = n \sum_{i=1}^n \frac{1}{n} [\mathbb{I}(U_i, V_i; Y_i|T=i) - \mathbb{I}(U_i; S_i|V_i, T=i)] + n\epsilon_n \\
& = n \sum_{i=1}^n \mathbb{P}(T=i) [\mathbb{I}(U_i, V_i; Y_i|T=i) - \mathbb{I}(U_i; S_i|V_i, T=i)] + n\epsilon_n \\
& = n [\mathbb{I}(U_T, V_T; Y_T|T) - \mathbb{I}(U_T; S_T|V_T, T)] + n\epsilon_n
\end{aligned}$$

$$\begin{aligned}
&\leq [\mathbb{I}(U_T, V_T, T; Y_T) - \mathbb{I}(U_T; S_T | V_T, T)] + n\epsilon_n \\
&\stackrel{(d)}{=} n[\mathbb{I}(U, V; Y) - \mathbb{I}(U; S | V)] + n\epsilon_n \\
&\stackrel{(e)}{\leq} n[\mathbb{I}(U, V; Y) - \mathbb{I}(U; S | V)] + n\epsilon,
\end{aligned} \tag{175}$$

where

- (a) follows from Fano's inequality for n large enough and the fact that conditioning does not increase entropy;
- (b) follows from Csiszár-Körner sum identity [35, Lemma 7];
- (c) follows by defining $U_i \triangleq (M, Y^{i-1}, S_{i+1}^n)$ and $V_i \triangleq (M, Z^{i-1}, S_{i+1}^n)$;
- (d) follows by defining $U = (U_T, T)$, $V = (V_T, T)$, $Y = Y_T$, and $S = S_T$;
- (e) follows from definition $\epsilon \triangleq \max\{\epsilon_n, \nu\}$.

Next, we lower bound nR as follows.

$$\begin{aligned}
nR &\geq \mathbb{H}(M) \\
&\geq \mathbb{I}(M; Z^n) \\
&= \sum_{i=1}^n \mathbb{I}(M; Z_i | Z^{i-1}) \\
&= \sum_{i=1}^n [\mathbb{I}(M, S_{i+1}^n; Z_i | Z^{i-1}) - \mathbb{I}(S_{i+1}^n; Z_i | M, Z^{i-1})] \\
&\stackrel{(a)}{=} \sum_{i=1}^n [\mathbb{I}(M, S_{i+1}^n; Z_i | Z^{i-1}) - \mathbb{I}(Z^{i-1}; S_i | M, S_{i+1}^n)] \\
&\stackrel{(b)}{\geq} \sum_{i=1}^n [\mathbb{I}(M, S_{i+1}^n, Z^{i-1}; Z_i) - \mathbb{I}(Z^{i-1}; S_i | M, S_{i+1}^n)] - \delta \\
&\stackrel{(c)}{\geq} \sum_{i=1}^n [\mathbb{I}(M, S_{i+1}^n, Z^{i-1}; Z_i) - \mathbb{I}(M, S_{i+1}^n, Z^{i-1}; S_i)] - \delta \\
&\stackrel{(d)}{=} \sum_{i=1}^n [\mathbb{I}(V_i; Z_i) - \mathbb{I}(V_i; S_i)] - \delta \\
&= n \sum_{i=1}^n \frac{1}{n} [\mathbb{I}(V_i; Z_i | T = i) - \mathbb{I}(V_i; S_i | T = i)] - \delta \\
&= n \sum_{i=1}^n \mathbb{P}(T = i) [\mathbb{I}(V_i; Z_i | T = i) - \mathbb{I}(V_i; S_i | T = i)] - \delta \\
&= n [\mathbb{I}(V_T; Z_T | T) - \mathbb{I}(V_T; S_T | T)] - \delta \\
&\stackrel{(e)}{=} n [\mathbb{I}(V_T; Z_T | T) - \mathbb{I}(V_T, T; S_T)] - \delta \\
&\stackrel{(f)}{\geq} n [\mathbb{I}(V_T, T; Z_T) - \mathbb{I}(V_T, T; S_T)] - 2\delta \\
&\stackrel{(g)}{=} n [\mathbb{I}(V; Z) - \mathbb{I}(V; S)] - 2\delta
\end{aligned} \tag{176}$$

where

- (a) follows from Csiszár-Körner sum identity [35, Lemma 7];
- (b) follows from Lemma 3;
- (c) follows since S_i is independent of (M, S_{i+1}^n) ;

- (d) follows by defining $V_i \triangleq (M, S_{i+1}^n, Z^{i-1})$;
- (e) follows from the independence of S_T and T ;
- (f) follows from Lemma 3;
- (g) follows by defining $V = (V_T, T)$, $Z = Z_T$, and $S = S_T$.

For any $\nu > 0$, choosing n large enough ensures that

$$\begin{aligned} R &\geq \mathbb{I}(V; Z) - \mathbb{I}(V; S) - 2\nu \\ &\geq \mathbb{I}(V; Z) - \mathbb{I}(V; S) - 2\epsilon, \end{aligned} \quad (177)$$

where the last inequality follows from definition $\epsilon \triangleq \max\{\epsilon_n, \nu\}$. To show that $\mathbb{D}(P_Z||Q_0) \leq \epsilon$, note that for n large enough

$$\mathbb{D}(P_Z||Q_0) = \mathbb{D}(P_{Z_T}||Q_0) = \mathbb{D}\left(\frac{1}{n} \sum_{i=1}^n P_{Z_i} \middle| \middle| Q_0\right) \leq \frac{1}{n} \sum_{i=1}^n \mathbb{D}(P_{Z_i}||Q_0) \leq \frac{1}{n} \mathbb{D}(P_{Z^n}||Q_0^{\otimes n}) \leq \frac{\delta}{n} \leq \nu \leq \epsilon. \quad (178)$$

Combining (174), (175), (177), and (178) shows that $\forall \epsilon_n, \nu > 0$, $R \leq \max\{x : x \in \mathcal{S}_\epsilon\}$. Therefore,

$$R \leq \max \left\{ x : x \in \bigcap_{\epsilon > 0} \mathcal{S}_\epsilon \right\}. \quad (179)$$

B. Continuity at zero

The proof is available in Appendix I.

APPENDIX H PROOF OF LEMMA 3

First note that,

$$\begin{aligned} \sum_{i=1}^n \mathbb{I}(Z_i; Z^{i-1}) &= \sum_{i=1}^n [\mathbb{H}(Z_i) - \mathbb{H}(Z_i|Z^{i-1})] \\ &= \sum_{i=1}^n \mathbb{H}(Z_i) - \mathbb{H}(Z^n) \\ &= - \sum_{i=1}^n \sum_z P_{Z_i}(z) \log P_{Z_i}(z) + \sum_{z^n} P_{Z^n}(z^n) \log P_{Z^n}(z^n) \\ &= - \sum_{i=1}^n \sum_z P_{Z_i}(z) \log P_{Z_i}(z) + \sum_{i=1}^n \sum_z P_{Z_i}(z) \log Q_0(z) \\ &\quad - \sum_{i=1}^n \sum_z P_{Z_i}(z) \log Q_0(z) + \sum_{z^n} P_{Z^n}(z^n) \log P_{Z^n}(z^n) \\ &= - \sum_{i=1}^n \mathbb{D}(P_{Z_i}||Q_0) - \sum_{z^n} P_{Z^n}(z^n) \log Q_0^{\otimes n}(z^n) + \sum_{z^n} P_{Z^n}(z^n) \log P_{Z^n}(z^n) \\ &\leq \mathbb{D}(P_{Z^n}||Q_0^{\otimes n}) \\ &\leq \delta. \end{aligned}$$

Similarly one can proof $\sum_{i=1}^n \mathbb{I}(Z_i; Z_{i+1}^n) \leq \delta$. Next,

$$\mathbb{I}(Q; Z_Q) = \mathbb{H}(Z_Q) - \mathbb{H}(Z_Q|Q)$$

$$\begin{aligned}
&= - \sum_z \frac{1}{n} \sum_{i=1}^n P_{Z_i}(z) \log \frac{1}{n} \sum_{j=1}^n P_{Z_j}(z) + \frac{1}{n} \sum_{i=1}^n \sum_z P_{Z_i}(z) \log P_{Z_i}(z) \\
&= - \sum_z \frac{1}{n} \sum_{i=1}^n P_{Z_i}(z) \log \frac{1}{n} \sum_{j=1}^n P_{Z_j}(z) + \sum_z \frac{1}{n} \sum_{i=1}^n P_{Z_i}(z) \log Q_0(z) \\
&\quad - \sum_z \frac{1}{n} \sum_{i=1}^n P_{Z_i}(z) \log Q_0(z) + \frac{1}{n} \sum_{i=1}^n \sum_z P_{Z_i}(z) \log P_{Z_i}(z) \\
&= -\mathbb{D}\left(\frac{1}{n} \sum_{i=1}^n P_{Z_i} \middle\| Q_0\right) + \frac{1}{n} \sum_{i=1}^n \mathbb{D}(P_{Z_i} \| Q_0) \\
&\leq \frac{1}{n} \sum_{i=1}^n \mathbb{D}(P_{Z_i} \| Q_0) \\
&\leq \frac{1}{n} \mathbb{D}(P_{Z^n} \| Q_0^{\otimes n}) \\
&\leq \frac{\delta}{n}.
\end{aligned} \tag{180}$$

APPENDIX I CONTINUITY AT ZERO

Our objective is to show that the capacity region is included in the region defined in (29). The challenge, first highlighted in [26, Section VI.D], is that our converse arguments only establish that the capacity region is included in the region $\bigcap_{\epsilon > 0} \mathcal{S}_\epsilon$ where \mathcal{S}_ϵ is defined in (173). In the sequel, the continuity of the slackness in the mutual information inequality (173b) will assume some importance, hence for ease of expression we define and refer to $g(\epsilon) \triangleq 3\epsilon$. As ϵ vanishes, *both* the region \mathcal{S}_ϵ and the set of distributions \mathcal{D}_ϵ shrink, so that proving the continuity at $\epsilon = 0$ is not completely straightforward. We carefully lay out the arguments leading to the result in a series of lemmas.

Lemma 4. *For all $\epsilon > 0$, the set \mathcal{D}_ϵ is closed and bounded, hence compact.*

Proof. We need to check that every constraint defining the set \mathcal{D}_ϵ defines a close set of distributions, so that \mathcal{D}_ϵ is an intersection of closed sets and remains closed. First note that:

- the function that outputs the marginal P_Z of $P_{U,V,S,X,Y,Z}$ is continuous in P_Z ;
- Q_0 has support \mathcal{Z} so that the divergence $\mathbb{D}(P_Z \| Q_0)$ is a continuous function of P_Z ;
- mutual information, viewed as a function of the joint distribution of the random variables involved, is continuous;
- all the constraints in the definition of \mathcal{D}_ϵ are inequalities.

Consequently, the pre-images of the closed sets defined by the inequalities are pre-images of closed sets through continuous functions, hence closed. \mathcal{D}_ϵ is bounded because it is a subset of the probability simplex, hence it is compact. □

Lemma 5. *For all $\epsilon > 0$ the set \mathcal{S}_ϵ is non-empty, closed, and bounded.*

Proof. The set of Pareto optimal points in \mathcal{S}_ϵ is the image of \mathcal{D}_ϵ through a continuous function. Since \mathcal{D}_ϵ is compact, the set of Pareto optimal points is compact. In \mathbb{R} , compact sets are closed, hence the set of Pareto optimal points

is closed and \mathcal{S}_ϵ itself is closed by definition. \mathcal{S}_ϵ is also non empty because it contains 0. \mathcal{S}_ϵ is bounded because we can upper bound R by $2 \log |\mathcal{X}| + \epsilon$. \square

Now define the set

$$\mathcal{S}'_\epsilon \triangleq \left\{ R \geq 0 : \begin{array}{l} \exists P_{U,V,S,X,Y,Z} \in \mathcal{D}_\epsilon : R \leq \min\{\mathbb{I}(U; Y) - \mathbb{I}(U; S), \mathbb{I}(U, V; Y) - \mathbb{I}(U; S|V)\} \end{array} \right\}. \quad (181)$$

Note that \mathcal{S}'_ϵ differs from \mathcal{S}_ϵ in the absence of ϵ in the rate constraint.

Lemma 6. *For all $\epsilon > 0$ the set \mathcal{S}'_ϵ is closed and bounded.*

Proof. Similar to the proof of Lemma 5 \square

Lemma 7.

$$\bigcap_{\epsilon > 0} \mathcal{S}'_\epsilon = \bigcap_{\epsilon > 0} \mathcal{S}_\epsilon \quad (182)$$

Proof. First note that $\bigcap_{\epsilon > 0} \mathcal{S}'_\epsilon$ is closed, since it is an intersection of closed sets, and bounded, since the sets \mathcal{S}'_ϵ are nested and bounded. Hence, $\bigcap_{\epsilon > 0} \mathcal{S}'_\epsilon$ is compact. Consequently, there exists a maximal element, r^\dagger . Consider any $r \in [0, r^\dagger]$. Then $\forall \epsilon > 0 \exists P_{U,V,S,X,Y,Z} \in \mathcal{D}_\epsilon \quad r \leq r^\dagger \leq \min\{\mathbb{I}(U; Y) - \mathbb{I}(U; S), \mathbb{I}(U, V; Y) - \mathbb{I}(U; S|V)\}$ and $r \in \bigcap_{\epsilon > 0} \mathcal{S}'_\epsilon$.

We now want to show that $\bigcap_{\epsilon > 0} \mathcal{S}'_\epsilon = \bigcap_{\epsilon > 0} \mathcal{S}_\epsilon$. The hard part is showing that $\bigcap_{\epsilon > 0} \mathcal{S}_\epsilon \subset \bigcap_{\epsilon > 0} \mathcal{S}'_\epsilon$ since the other direction follows by the definition of \mathcal{S}_ϵ and \mathcal{S}'_ϵ . We proceed by contradiction. Assume $\exists r^* \in \bigcap_{\epsilon > 0} \mathcal{S}_\epsilon$ such that $r^* \notin \bigcap_{\epsilon > 0} \mathcal{S}'_\epsilon$. It must be that $r^\dagger < r^*$ for otherwise $r^* \in \bigcap_{\epsilon > 0} \mathcal{S}'_\epsilon$ as noted earlier.

Set $r_0 \triangleq \frac{1}{2}(r^\dagger + r^*)$, which is such that $r_0 > r^\dagger$ and therefore $r_0 \notin \bigcap_{\epsilon > 0} \mathcal{S}'_\epsilon$. Set $\epsilon' > 0$ such that $\forall \epsilon \leq \epsilon' \quad g(\epsilon) < \frac{r^* - r^\dagger}{2}$, which exists by the assumptions on g . Assume that $\forall \epsilon \in (0; \epsilon'] \quad r_0 \in \mathcal{S}'_\epsilon$. Then $r_0 \in \bigcap_{\epsilon > 0} \mathcal{S}'_\epsilon$ which contradicts our assumption. Hence, there exists $0 < \epsilon_0 \leq \epsilon'$ such that $r_0 \notin \mathcal{S}'_{\epsilon_0}$. Hence $\forall P_{U,V,S,X,Y,Z} \in \mathcal{D}_{\epsilon_0} \quad r_0 > \min\{\mathbb{I}(U; Y) - \mathbb{I}(U; S), \mathbb{I}(U, V; Y) - \mathbb{I}(U; S|V)\}$. Then $\forall P_{U,V,S,X,Y,Z} \in \mathcal{D}_{\epsilon_0}$

$$r_0 > \min\{\mathbb{I}(U; Y) - \mathbb{I}(U; S), \mathbb{I}(U, V; Y) - \mathbb{I}(U; S|V)\} \quad (183)$$

$$\Rightarrow \frac{r^* + r^\dagger}{2} > \min\{\mathbb{I}(U; Y) - \mathbb{I}(U; S), \mathbb{I}(U, V; Y) - \mathbb{I}(U; S|V)\} \quad (184)$$

$$\Rightarrow \frac{r^* + r^\dagger}{2} + \frac{r^* - r^\dagger}{2} > \min\{\mathbb{I}(U; Y) - \mathbb{I}(U; S), \mathbb{I}(U, V; Y) - \mathbb{I}(U; S|V)\} + \frac{r^* - r^\dagger}{2} \quad (185)$$

$$\Rightarrow r^* > \min\{\mathbb{I}(U; Y) - \mathbb{I}(U; S), \mathbb{I}(U, V; Y) - \mathbb{I}(U; S|V)\} + g(\epsilon_0) \quad (186)$$

Since $r^* \in \bigcap_{\epsilon > 0} \mathcal{S}_\epsilon$, we have $\forall \epsilon > 0 \exists P_{U,V,S,X,Y,Z} \in \mathcal{D}_\epsilon$ such that $r^* \leq \min\{\mathbb{I}(U; Y) - \mathbb{I}(U; S), \mathbb{I}(U, V; Y) - \mathbb{I}(U; S|V)\} + g(\epsilon)$. Hence, there is a contradiction and we must have $r^* \in \bigcap_{\epsilon > 0} \mathcal{S}'_\epsilon$. \square

To conclude, one can prove that $\bigcap_{\epsilon > 0} \mathcal{S}'_\epsilon = \mathcal{S}_0$, following the exact same arguments as in [26, Section IV.C].

APPENDIX J

PROOF OF THEOREM 7

We adopt a block-Markov encoding scheme in which B independent messages are transmitted over B channel blocks each of length r , such that $n = rB$. The warden's observation is $Z^n = (Z_1^r, \dots, Z_B^r)$, the distribution

induced at the output of the warden is P_Z^n , the target output distribution is $Q_Z^{\otimes n}$, and Equation (81), describing the distance between the two distributions, continues to hold. The random code generation is as follows:

Fix $P_U(u)$, $P_{V|S}(v|s)$, $x(u, s)$, and $\epsilon_1 > \epsilon_2 > 0$ such that, $P_Z = Q_0$.

Codebook Generation for Keys: For each block $j \in \llbracket 1 : B \rrbracket$, let $C_1^{(r)} \triangleq \{V^r(\ell_j)\}_{\ell_j \in \mathcal{L}}$, where $\mathcal{L} = \llbracket 1 : 2^{r\tilde{R}} \rrbracket$, be a random codebook consisting of independent random sequences each generated according to $P_V^{\otimes r}$, where $P_V = \sum_{s \in \mathcal{S}} Q_S(s)P_{V|S}(v|s)$. We denote a realization of $C_1^{(r)}$ by $\mathcal{C}_1^{(r)} \triangleq \{v^r(\ell_j)\}_{\ell_j \in \mathcal{L}}$. Partition the set of indices $\ell_j \in \llbracket 1 : 2^{r\tilde{R}} \rrbracket$ into bins $\mathcal{B}(t)$, $t \in \llbracket 1 : 2^{rR_t} \rrbracket$ by using function $\varphi : V^r(\ell_j) \rightarrow \llbracket 1 : 2^{rR_t} \rrbracket$ through random binning by choosing the value of $\varphi(v^r(\ell_j))$ independently and uniformly at random for every $v^r(\ell_j) \in \mathcal{V}^r$. For each block $j \in \llbracket 1 : B \rrbracket$, create a function $\Phi : V^r(\ell_j) \rightarrow \llbracket 1 : 2^{rR_k} \rrbracket$ through random binning by choosing the value of $\Phi(v^r(\ell_j))$ independently and uniformly at random for every $v^r(\ell_j) \in \mathcal{V}^r$. The key $k_j = \Phi(v^r(\ell_j))$ obtained in block $j \in \llbracket 1 : B \rrbracket$ from the description of the channel state sequence $v^r(\ell_j)$ is used to assist the encoder in block $j + 2$.

Codebook Generation for Messages: For each block $j \in \llbracket 1 : B \rrbracket$, let $C_2^{(r)} \triangleq \{U^r(m_j, t_{j-1}, k_{j-2})\}_{(m_j, t_{j-1}, k_{j-2}) \in \mathcal{M} \times \mathcal{T} \times \mathcal{K}}$, where $\mathcal{M} = \llbracket 1 : 2^{rR} \rrbracket$, $\mathcal{T} = \llbracket 1 : 2^{rR_t} \rrbracket$, and $\mathcal{K} = \llbracket 1 : 2^{rR_k} \rrbracket$, be a random codebook consisting of independent random sequences each generated according to $P_U^{\otimes r}$. We denote a realization of $C_2^{(r)}$ by $\mathcal{C}_2^{(r)} \triangleq \{u^r(m_j, t_{j-1}, k_{j-2})\}_{(m_j, t_{j-1}, k_{j-2}) \in \mathcal{M} \times \mathcal{T} \times \mathcal{K}}$. Let, $C_r = \{\mathcal{C}_1^{(r)}, \mathcal{C}_2^{(r)}\}$ and $\mathcal{C}_r = \{\mathcal{C}_1^{(r)}, \mathcal{C}_2^{(r)}\}$. The indices (m_j, t_{j-1}, k_{j-2}) can be viewed as a two layer binning. We define an ideal PMF for codebook \mathcal{C}_n , as an approximate distribution to facilitate the analysis

$$\begin{aligned} & \Gamma_{M_j, T_{j-1}, K_{j-2}, L_j, U^r, V^r, S_j^r, Z_j^r, K_{j-1}, T_j, K_j}(m_j, t_{j-1}, k_{j-2}, \ell_j, \tilde{u}^r, \tilde{v}^r, s_j^r, z_j^r, k_{j-1}, t_j, k_j) \\ &= 2^{-r(R+R_t+R_k+\tilde{R})} \mathbb{1}_{\{\tilde{u}^r = u^r(m_j, t_{j-1}, k_{j-2})\}} \mathbb{1}_{\{\tilde{v}^r = v^r(\ell_j)\}} P_{S|V}^{\otimes r}(s_j^r | \tilde{v}^r) W_{Z|U, S}^{\otimes r}(z_j^r | \tilde{u}^r, s_j^r) \\ & \quad \times 2^{-rR_k} \mathbb{1}_{\{t_j = \varphi(\tilde{v}^r)\}} \mathbb{1}_{\{k_j = \Phi(\tilde{v}^r)\}}, \end{aligned} \quad (187)$$

where $W_{Z|U, S}$ is the marginal distribution of $W_{Z|U, S} = \sum_{x \in \mathcal{X}} \mathbb{1}_{\{x = x(u, s)\}} W_{Z|X, S}$ and

$$P_{S|V} = \frac{P_{S, V}(s, v)}{P_V(v)} = \frac{Q_S(s)P_{V|S}(v|s)}{\sum_{s \in \mathcal{S}} Q_S(s)P_{V|S}(v|s)}. \quad (188)$$

Encoding: We assume that the transmitter and the receiver have access to shared secret keys k_{-1} and k_0 for the first two blocks but after the first two blocks they use the key that they generate from the CSI.

In the first block, to send the message m_1 according to k_{-1} , the encoder chooses the index t_0 uniformly at random (the index t_0 does not carry any useful information) and computes $u^r(m_1, t_0, k_{-1})$ and transmits a codeword x^r , where $x_i = x(u_i(m_1, t_0, k_{-1}), s_{1,i})$.

At the beginning of the second block, to generate a secret key shared between the transmitter and the receiver, the encoder chooses the index ℓ_1 according to the following distribution with $j = 1$,

$$f(\ell_j | s_j^r) = \frac{P_{S|V}^{\otimes r}(s_j^r | v^r(\ell_j))}{\sum_{\ell' \in \llbracket 1 : 2^{r\tilde{R}} \rrbracket} P_{S|V}^{\otimes r}(s_j^r | v^r(\ell'))}, \quad (189)$$

where $P_{S|V}$ is defined in (188). Then generates the reconciliation index $t_1 = \varphi(v^r(\ell_1))$; simultaneously the transmitter generates a key $k_1 = \Phi(v^r(\ell_1))$ from the description of its CSI of the first block $v^r(\ell_1)$ to be used in the next block. To transmit the message m_2 and reconciliation index t_1 according to the key k_0 the encoder computes $u^r(m_2, t_1, k_0)$ and transmits a codeword x^r , where $x_i = x(u_i(m_2, t_1, k_0), s_{2,i})$.

In block $j \in \llbracket 3 : B \rrbracket$, the encoder first selects the index ℓ_{j-1} based s_{j-1}^r by using the likelihood encoder described in (189) and then generates the reconciliation index $t_{j-1} = \varphi(v^r(\ell_{j-1}))$; simultaneously the encoder generates a

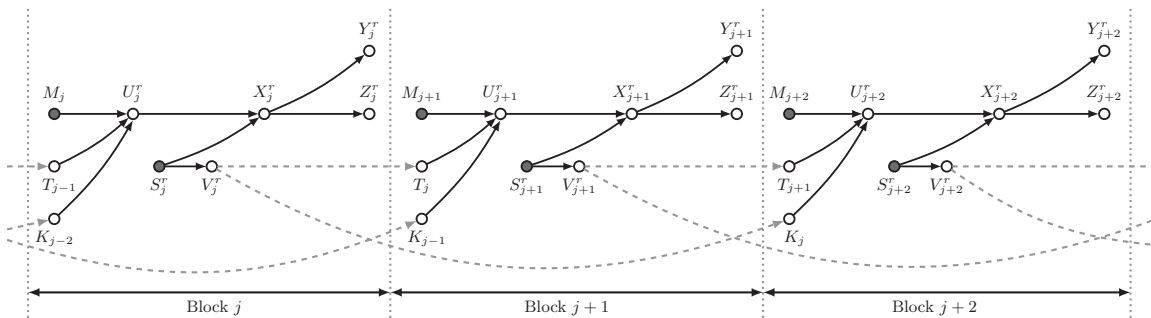

Fig. 12. Functional dependence graph for the block-Markov encoding scheme

key $k_{j-1} = \Phi(v^r(\ell_{j-1}))$ from the description of its CSI of the block $j-1$, $v^r(\ell_{j-1})$, to be used in the next block. Then to send message m_j and reconciliation index t_{j-1} according to the generated key k_{j-2} from the previous block and the CSI of the current block s_j^r , the encoder computes $u^r(m_j, t_{j-1}, k_{j-2})$ and transmits a codeword x^r , where each coordinate of the transmitted signal is a function of the current state s_j^r as well as the corresponding sample of the transmitter's codeword u_i , i.e., $x_i = x(u_i(m_j, t_{j-1}, k_{j-2}), s_{j,i}^r)$.

Define

$$\begin{aligned} & \Upsilon_{M_j, T_{j-1}, K_{j-2}, U^r, S_j^r, L_j, V^r, Z_j^r, K_{j-1}, T_j, K_j}^{(C_r)}(m_j, t_{j-1}, k_{j-2}, \tilde{u}^r, s_j^r, \ell_j, \tilde{v}^r, z_j^r, k_{j-1}, t_j, k_j) \\ & \triangleq 2^{-r(R+R_t+R_k)} \mathbb{1}_{\{\tilde{u}^r = u^r(m_j, t_{j-1}, k_{j-2})\}} Q_S^{\otimes r}(s_j^r) f(\ell_j | s_j^r) \mathbb{1}_{\{\tilde{v}^r = v^r(\ell_j)\}} \\ & \quad \times W_{Z|U, S}^{\otimes r}(z_j^r | \tilde{u}^r, s_j^r) 2^{-rR_k} \mathbb{1}_{\{t_j = \varphi(\tilde{v}^r)\}} \mathbb{1}_{\{k_j = \Phi(\tilde{v}^r)\}}. \end{aligned} \quad (190)$$

For a fixed codebook \mathcal{C}_r , the induced joint distribution over the codebook (i.e. $P^{(C_r)}$) satisfies

$$\mathbb{D}\left(P_{M_j, T_{j-1}, K_{j-2}, U^r, S_j^r, L_j, V^r, Z_j^r, K_{j-1}, T_j, K_j}^{(C_r)} \parallel \Upsilon_{M_j, T_{j-1}, K_{j-2}, U^r, S_j^r, L_j, V^r, Z_j^r, K_{j-1}, T_j, K_j}^{(C_r)}\right) \leq \epsilon. \quad (191)$$

This intermediate distribution $\Upsilon^{(C_r)}$ approximates the true distribution $P^{(C_r)}$ and will be used in the sequel for bounding purposes. Expression (191) holds because the main difference in $\Upsilon^{(C_r)}$ is assuming the keys K_{j-2} , K_{j-1} and the reconciliation index T_{j-1} are uniformly distributed, which is made (arbitrarily) nearly uniform in $P^{(C_r)}$ with appropriate control of rate.

Covert Analysis: We now show that this coding scheme guarantees that $\mathbb{E}_{C_n} [\mathbb{D}(P_{Z^n|C_n} \parallel Q_Z^{\otimes n})] \xrightarrow{n \rightarrow \infty} 0$, where C_n is the set of all the codebooks for all blocks, and then choose P_U , P_V , and $x(u, s)$ such that it satisfies $Q_Z = Q_0$. Similar to (137) using the functional dependence graph depicted in Fig. 12 it follows that,

$$\mathbb{D}(P_{Z^n} \parallel Q_Z^{\otimes n}) \leq 2 \sum_{j=1}^B \mathbb{D}(P_{Z_j^r, K_{j-1}, T_j, K_j} \parallel Q_Z^{\otimes r} Q_{K_{j-1}} Q_{T_j} Q_{K_j}). \quad (192)$$

To bound the RHS of (192) by using Lemma 1 and the triangle inequality we have,

$$\begin{aligned} & \mathbb{E}_{C_r} \left\| P_{Z_j^r, K_{j-1}, T_j, K_j} \Big|_{C_r} - Q_Z^{\otimes r} Q_{K_{j-1}} Q_{T_j} Q_{K_j} \right\|_1 \\ & \leq \mathbb{E}_{C_r} \left\| P_{Z_j^r, K_{j-1}, T_j, K_j} \Big|_{C_r} - \Gamma_{Z_j^r, K_{j-1}, T_j, K_j} \Big|_{C_r} \right\|_1 + \mathbb{E}_{C_r} \left\| \Gamma_{Z_j^r, K_{j-1}, T_j, K_j} \Big|_{C_r} - Q_Z^{\otimes r} Q_{K_{j-1}} Q_{T_j} Q_{K_j} \right\|_1 \\ & \leq \mathbb{E}_{C_r} \left\| P_{Z_j^r, K_{j-1}, T_j, K_j} \Big|_{C_r} - \Upsilon_{Z_j^r, K_{j-1}, T_j, K_j} \Big|_{C_r} \right\|_1 + \mathbb{E}_{C_r} \left\| \Upsilon_{Z_j^r, K_{j-1}, T_j, K_j} \Big|_{C_r} - \Gamma_{Z_j^r, K_{j-1}, T_j, K_j} \Big|_{C_r} \right\|_1 \\ & \quad + \mathbb{E}_{C_r} \left\| \Gamma_{Z_j^r, K_{j-1}, T_j, K_j} \Big|_{C_r} - Q_Z^{\otimes r} Q_{K_{j-1}} Q_{T_j} Q_{K_j} \right\|_1. \end{aligned} \quad (193)$$

From (191) and the monotonicity of KL-divergence the first term on the RHS of (193) goes to zero when r grows. To bound the second term on the RHS of (193) for a fixed codebook \mathcal{C}_r we have,

$$\Gamma_{M_j, T_{j-1}, K_{j-2}}^{(\mathcal{C}_r)} = 2^{-r(R+R_t+R_k)} = \Upsilon_{M_j, T_{j-1}, K_{j-2}}^{(\mathcal{C}_r)}, \quad (194a)$$

$$\Gamma_{U^r|M_j, T_{j-1}, K_{j-2}, S_j^r}^{(\mathcal{C}_r)} = \mathbb{1}\{\tilde{u}^r = u^r(m_j, t_{j-1}, k_{j-2})\} = \Upsilon_{U^r|M_j, T_{j-1}, K_{j-2}, S_j^r}^{(\mathcal{C}_r)}, \quad (194b)$$

$$\Gamma_{L_j|M_j, T_{j-1}, K_{j-2}, S_j^r, U^r}^{(\mathcal{C}_r)} = f(\ell_j|s_j^r) = \Upsilon_{L_j|M_j, T_{j-1}, K_{j-2}, S_j^r, U^r}^{(\mathcal{C}_r)}, \quad (194c)$$

$$\Gamma_{V^r|M_j, T_{j-1}, K_{j-2}, S_j^r, L_j, U^r}^{(\mathcal{C}_r)} = \mathbb{1}\{\tilde{v}^r = v^r(\ell_j)\} = \Upsilon_{V^r|M_j, T_{j-1}, K_{j-2}, S_j^r, L_j, U^r}^{(\mathcal{C}_r)}, \quad (194d)$$

$$\Gamma_{Z_j^r|M_j, T_{j-1}, K_{j-2}, S_j^r, L_j, U^r, V^r}^{(\mathcal{C}_r)} = W_{Z|U, S}^{\otimes r} = \Upsilon_{Z_j^r|M_j, T_{j-1}, K_{j-2}, S_j^r, L_j, U^r, V^r}^{(\mathcal{C}_r)}, \quad (194e)$$

$$\Gamma_{K_{j-1}|M_j, T_{j-1}, K_{j-2}, S_j^r, L_j, U^r, V^r, Z_j^r}^{(\mathcal{C}_r)} = 2^{-rR_k} = \Upsilon_{K_{j-1}|M_j, T_{j-1}, K_{j-2}, S_j^r, L_j, U^r, V^r, Z_j^r}^{(\mathcal{C}_r)}, \quad (194f)$$

$$\Gamma_{T_j|M_j, T_{j-1}, K_{j-2}, S_j^r, L_j, U^r, V^r, Z_j^r}^{(\mathcal{C}_r)} = \mathbb{1}\{t_j = \sigma(v^r(\ell_j))\} = \Upsilon_{T_j|M_j, T_{j-1}, K_{j-2}, S_j^r, L_j, U^r, V^r, Z_j^r}^{(\mathcal{C}_r)}, \quad (194g)$$

$$\Gamma_{K_j|M_j, T_{j-1}, K_{j-2}, S_j^r, L_j, U^r, V^r, Z_j^r, T_j}^{(\mathcal{C}_r)} = \mathbb{1}\{k_j = \Phi(v^r(\ell_j))\} = \Upsilon_{K_j|M_j, T_{j-1}, K_{j-2}, S_j^r, L_j, U^r, V^r, Z_j^r, T_j}^{(\mathcal{C}_r)}, \quad (194h)$$

where (194c) follows from (189). Hence,

$$\begin{aligned} & \mathbb{E}_{\mathcal{C}_r} \|\Upsilon_{Z_j^r, K_{j-1}, T_j, K_j | \mathcal{C}_r} - \Gamma_{Z_j^r, K_{j-1}, T_j, K_j | \mathcal{C}_r}\|_1 \\ & \leq \mathbb{E}_{\mathcal{C}_r} \|\Upsilon_{M_j, T_{j-1}, K_{j-2}, S_j^r, L_j, U^r, V^r, Z_j^r, K_{j-1}, T_j, K_j | \mathcal{C}_r} - \Gamma_{M_j, T_{j-1}, K_{j-2}, S_j^r, L_j, U^r, V^r, Z_j^r, K_{j-1}, T_j, K_j | \mathcal{C}_r}\|_1 \\ & \stackrel{(a)}{=} \mathbb{E}_{\mathcal{C}_r} \|\Upsilon_{M_j, T_{j-1}, K_{j-2}, S_j^r | \mathcal{C}_r} - \Gamma_{M_j, T_{j-1}, K_{j-2}, S_j^r | \mathcal{C}_r}\|_1 \\ & \stackrel{(b)}{=} \mathbb{E}_{\mathcal{C}_r} \|\mathbb{Q}_S^{\otimes r} - \Gamma_{S_j^r | M_j=1, T_{j-1}=1, K_{j-2}=1, \mathcal{C}_r}\|_1, \end{aligned} \quad (195)$$

where (a) follows from (194b)-(194h) and (b) follows from the symmetry of the codebook construction with respect to M_j , T_{j-1} , and K_{j-2} and (194a). Based on the soft covering lemma [26, Corollary VII.5] the RHS of (195) vanishes when r grows if

$$\tilde{R} > \mathbb{I}(S; V). \quad (196)$$

We now proceed to bound the third term on the RHS of (193). First, consider the marginal,

$$\begin{aligned} & \Gamma_{Z_j^r, K_{j-1}, T_j, K_j | \mathcal{C}_r}(z_j^r, k_{j-1}, t_j, k_j) \\ & = \sum_{m_j} \sum_{t_{j-1}} \sum_{k_{j-2}} \sum_{\ell_j} \sum_{s_j^r} \frac{1}{2^{r(R+R_t+2R_k+\tilde{R})}} P_{S|V}^{\otimes r}(s_j^r | V^r(\ell_j)) \\ & \quad \times W_{Z|U, S}^{\otimes r}(z_j^r | U^r(m_j, t_{j-1}, k_{j-2}), s_j^r) \mathbb{1}\{t_j = \varphi(V^r(\ell_j))\} \mathbb{1}\{k_j = \Phi(V^r(\ell_j))\} \\ & = \sum_{m_j} \sum_{t_{j-1}} \sum_{k_{j-2}} \sum_{\ell_j} \frac{1}{2^{r(R+R_t+2R_k+\tilde{R})}} W_{Z|U, V}^{\otimes r}(z_j^r | U^r(m_j, t_{j-1}, k_{j-2}), V^r(\ell_j)) \mathbb{1}\{t_j = \varphi(V^r(\ell_j))\} \mathbb{1}\{k_j = \Phi(V^r(\ell_j))\}, \end{aligned} \quad (197)$$

where $W_{Z|U, V}(z|u, v) = \sum_{s \in \mathcal{S}} P_{S|V}(s|v) W_{Z|U, S}(z|u, s)$. To bound the third term on the RHS of (193) by using Pinsker's inequality, it is sufficient to bound $\mathbb{E}_{\mathcal{C}_r} [\mathbb{D}(\Gamma_{Z_j^r, K_{j-1}, T_j, K_j | \mathcal{C}_r} \| \mathbb{Q}_Z^{\otimes r} \mathbb{Q}_{K_{j-1}} \mathbb{Q}_{T_j} \mathbb{Q}_{K_j})]$ as follows,

$$\begin{aligned} & \mathbb{E}_{\mathcal{C}_r} [\mathbb{D}(\Gamma_{Z_j^r, K_{j-1}, T_j, K_j | \mathcal{C}_r} \| \mathbb{Q}_Z^{\otimes r} \mathbb{Q}_{K_{j-1}} \mathbb{Q}_{T_j} \mathbb{Q}_{K_j})] \\ & = \mathbb{E}_{\mathcal{C}_r} \left[\sum_{z_j^r, k_{j-1}, t_j, k_j} \Gamma_{Z_j^r, K_{j-1}, T_j, K_j | \mathcal{C}_r}(z_j^r, k_{j-1}, t_j, k_j) \log \left(\frac{\Gamma_{Z_j^r, K_{j-1}, T_j, K_j | \mathcal{C}_r}(z_j^r, k_{j-1}, t_j, k_j)}{\mathbb{Q}_Z^{\otimes r}(z_j^r) \mathbb{Q}_{K_{j-1}}(k_{j-1}) \mathbb{Q}_{T_j}(t_j) \mathbb{Q}_{K_j}(k_j)} \right) \right] \\ & = \mathbb{E}_{\mathcal{C}_r} \left[\sum_{(z_j^r, k_{j-1}, t_j, k_j)} \sum_{m_j} \sum_{t_{j-1}} \sum_{k_{j-2}} \sum_{\ell_j} \frac{W_{Z|U, V}^{\otimes r}(z_j^r | U^r(m_j, t_{j-1}, k_{j-2}), V^r(\ell_j)) \mathbb{1}\{t_j = \varphi(V^r(\ell_j))\} \mathbb{1}\{k_j = \Phi(V^r(\ell_j))\}}{2^{r(R+R_t+2R_k+\tilde{R})}} \right] \end{aligned}$$

$$\begin{aligned}
& \times \log \left(\frac{\sum_{\tilde{m}_j} \sum_{\tilde{t}_{j-1}} \sum_{\tilde{k}_{j-2}} \sum_{\tilde{\ell}_j} W_{Z|U,V}^{\otimes r}(z_j^r | U^r(\tilde{m}_j, \tilde{t}_{j-1}, \tilde{k}_{j-2}), V^r(\tilde{\ell}_j)) \mathbb{1}_{\{t_j = \varphi(V^r(\tilde{\ell}_j))\}} \mathbb{1}_{\{k_j = \Phi(V^r(\tilde{\ell}_j))\}}}{2^{r(R+R_t+R_k+\tilde{R}-R_T-R_K)} Q_Z^{\otimes r}(z_j^r)} \right) \\
& \stackrel{(a)}{\leq} \sum_{(z_j^r, k_{j-1}, t_j, k_j)} \sum_{m_j} \sum_{t_{j-1}} \sum_{k_{j-2}} \sum_{\ell_j} \frac{1}{2^{r(R+R_t+2R_k+\tilde{R})}} \sum_{(u^r(m_j, t_{j-1}, k_{j-2}), v^r(\ell_j))} \Gamma_{U^r, V^r, Z_j^r}^{(C_r)}(u^r(m_j, t_{j-1}, k_{j-2}), v^r(\ell_j), z_j^r) \\
& \times \mathbb{E}_{\varphi(v^r(\ell_j))} [\mathbb{1}_{\{t_j = \varphi(v^r(\ell_j))\}}] \times \mathbb{E}_{\Phi(v^r(\ell_j))} [\mathbb{1}_{\{k_j = \Phi(v^r(\ell_j))\}}] \\
& \times \log \mathbb{E}_{\substack{\setminus (m_j, t_{j-1}, k_{j-2}, \ell_j), \\ \setminus (\varphi(v^r(\ell_j)), \Phi(v^r(\ell_j)))}} \left[\frac{\sum_{\tilde{m}_j} \sum_{\tilde{t}_{j-1}} \sum_{\tilde{k}_{j-2}} \sum_{\tilde{\ell}_j} W_{Z|U,V}^{\otimes r}(z_j^r | U^r(\tilde{m}_j, \tilde{t}_{j-1}, \tilde{k}_{j-2}), V^r(\tilde{\ell}_j)) \mathbb{1}_{\{t_j = \varphi(V^r(\tilde{\ell}_j))\}} \mathbb{1}_{\{k_j = \Phi(V^r(\tilde{\ell}_j))\}}}{2^{r(R+R_t+R_k+\tilde{R}-R_T-R_K)} Q_Z^{\otimes r}(z_j^r)} \right] \\
& \stackrel{(b)}{\leq} \sum_{(z_j^r, k_{j-1}, t_j, k_j)} \sum_{m_j} \sum_{t_{j-1}} \sum_{k_{j-2}} \sum_{\ell_j} \frac{1}{2^{r(R+R_t+2R_k+\tilde{R}+R_T+R_K)}} \sum_{(u^r(m_j, t_{j-1}, k_{j-2}), v^r(\ell_j))} \Gamma_{U^r, V^r, Z_j^r}^{(C_r)}(u^r(m_j, t_{j-1}, k_{j-2}), v^r(\ell_j), z_j^r) \\
& \times \log \frac{1}{2^{r(R+R_t+R_k+\tilde{R}-R_T-R_K)} Q_Z^{\otimes r}(z_j^r)} \times \left(W_{Z|U,V}^{\otimes r}(z_j^r | u^r(m_j, t_{j-1}, k_{j-2}), v^r(\ell_j)) \right. \\
& \left. + \mathbb{E}_{\setminus (m_j, t_{j-1}, k_{j-2})} \left[\sum_{(\tilde{m}_j, \tilde{t}_{j-1}, \tilde{k}_{j-2}) \neq (m_j, t_{j-1}, k_{j-2})} W_{Z|U,V}^{\otimes r}(z_j^r | U^r(\tilde{m}_j, \tilde{t}_{j-1}, \tilde{k}_{j-2}), v^r(\ell_j)) \right] \right. \\
& \left. + \mathbb{E}_{\substack{\setminus \ell_j, \\ \setminus (\varphi(v^r(\ell_j)), \Phi(v^r(\ell_j)))}} \left[\sum_{\tilde{\ell}_j \neq \ell_j} W_{Z|U,V}^{\otimes r}(z_j^r | u^r(m_j, t_{j-1}, k_{j-2}), V^r(\tilde{\ell}_j)) \mathbb{1}_{\{t_j = \varphi(V^r(\tilde{\ell}_j))\}} \mathbb{1}_{\{k_j = \Phi(V^r(\tilde{\ell}_j))\}} \right] \right. \\
& \left. + \mathbb{E}_{\substack{\setminus (m_j, t_{j-1}, k_{j-2}, \ell_j), \\ \setminus (\varphi(v^r(\ell_j)), \Phi(v^r(\ell_j)))}} \left[\sum_{\tilde{\ell}_j \neq \ell_j} \sum_{(\tilde{m}_j, \tilde{t}_{j-1}, \tilde{k}_{j-2}) \neq (m_j, t_{j-1}, k_{j-2})} W_{Z|U,V}^{\otimes r}(z_j^r | U^r(\tilde{m}_j, \tilde{t}_{j-1}, \tilde{k}_{j-2}), V^r(\tilde{\ell}_j)) \mathbb{1}_{\{t_j = \varphi(V^r(\tilde{\ell}_j))\}} \mathbb{1}_{\{k_j = \Phi(V^r(\tilde{\ell}_j))\}} \right] \right) \\
& \stackrel{(c)}{\leq} \sum_{(z_j^r, k_{j-1}, t_j, k_j)} \sum_{m_j} \sum_{t_{j-1}} \sum_{k_{j-2}} \sum_{\ell_j} \frac{1}{2^{r(R+R_t+2R_k+\tilde{R}+R_T+R_K)}} \sum_{(u^r(m_j, t_{j-1}, k_{j-2}), v^r(\ell_j))} \Gamma_{U^r, V^r, Z_j^r}^{(C_r)}(u^r(m_j, t_{j-1}, k_{j-2}), v^r(\ell_j), z_j^r) \\
& \times \log \left(\frac{W_{Z|U,V}^{\otimes r}(z_j^r | u^r(m_j, t_{j-1}, k_{j-2}), v^r(\ell_j))}{2^{r(R+R_t+R_k+\tilde{R}-R_T-R_K)} Q_Z^{\otimes r}(z_j^r)} + \sum_{(\tilde{m}_j, \tilde{t}_{j-1}, \tilde{k}_{j-2}) \neq (m_j, t_{j-1}, k_{j-2})} \frac{W_{Z|V}^{\otimes r}(z_j^r | v^r(\ell_j))}{2^{r(R+R_t+R_k+\tilde{R}-R_T-R_K)} Q_Z^{\otimes r}(z_j^r)} \right. \\
& \left. + \sum_{\tilde{\ell}_j \neq \ell_j} \frac{W_{Z|U}^{\otimes r}(z_j^r | u^r(m_j, t_{j-1}, k_{j-2}))}{2^{r(R+R_t+R_k+\tilde{R})} Q_Z^{\otimes r}(z_j^r)} + 1 \right) \\
& \leq \sum_{(z_j^r, k_{j-1}, t_j, k_j)} \sum_{m_j} \sum_{t_{j-1}} \sum_{k_{j-2}} \sum_{\ell_j} \frac{1}{2^{r(R+R_t+2R_k+\tilde{R}+R_T+R_K)}} \sum_{(u^r(m_j, t_{j-1}, k_{j-2}), v^r(\ell_j))} \Gamma_{U^r, V^r, Z_j^r}^{(C_r)}(u^r(m_j, t_{j-1}, k_{j-2}), v^r(\ell_j), z_j^r) \\
& \times \log \left(\frac{W_{Z|U,V}^{\otimes r}(z_j^r | u^r(m_j, t_{j-1}, k_{j-2}), v^r(\ell_j))}{2^{r(R+R_t+R_k+\tilde{R}-R_T-R_K)} Q_Z^{\otimes r}(z_j^r)} + \frac{W_{Z|V}^{\otimes r}(z_j^r | v^r(\ell_j))}{2^{r(\tilde{R}-R_T-R_K)} Q_Z^{\otimes r}(z_j^r)} + \frac{W_{Z|U}^{\otimes r}(z_j^r | u^r(m_j, t_{j-1}, k_{j-2}))}{2^{r(R+R_t+R_k)} Q_Z^{\otimes r}(z_j^r)} + 1 \right) \\
& \triangleq \Psi_1 + \Psi_2, \tag{198}
\end{aligned}$$

where (a) follows from Jensen's inequality, (b) and (c) hold because $\mathbb{1}_{\{k_j = \Phi(\tilde{s}_j^r)\}} \leq 1$. We defined Ψ_1 and Ψ_2 as

$$\begin{aligned}
\Psi_1 &= \sum_{(k_{j-1}, t_j, k_j)} \sum_{m_j} \sum_{t_{j-1}} \sum_{k_{j-2}} \sum_{\ell_j} \frac{1}{2^{r(R+R_t+2R_k+\tilde{R}+R_T+R_K)}} \sum_{(u^r(m_j, t_{j-1}, k_{j-2}), v^r(\ell_j), z_j^r) \in \mathcal{T}_\epsilon^{(r)}} \Gamma_{U^r, V^r, Z_j^r}^{(C_r)}(u^r(m_j, t_{j-1}, k_{j-2}), v^r(\ell_j), z_j^r) \\
& \times \log \left(\frac{W_{Z|U,V}^{\otimes r}(z_j^r | u^r(m_j, t_{j-1}, k_{j-2}), v^r(\ell_j))}{2^{r(R+R_t+R_k+\tilde{R}-R_T-R_K)} Q_Z^{\otimes r}(z_j^r)} + \frac{W_{Z|V}^{\otimes r}(z_j^r | v^r(\ell_j))}{2^{r(\tilde{R}-R_T-R_K)} Q_Z^{\otimes r}(z_j^r)} + \frac{W_{Z|U}^{\otimes r}(z_j^r | u^r(m_j, t_{j-1}, k_{j-2}))}{2^{r(R+R_t+R_k)} Q_Z^{\otimes r}(z_j^r)} + 1 \right)
\end{aligned}$$

$$\leq \log \left(\frac{2^{r(R_T+R_K)} \times 2^{-r(1-\epsilon)\mathbb{H}(Z|U,V)}}{2^{r(R+R_t+R_k+\tilde{R})} \times 2^{-r(1+\epsilon)\mathbb{H}(Z)}} + \frac{2^{r(R_T+R_K)} \times 2^{-r(1-\epsilon)\mathbb{H}(Z|V)}}{2^{r\tilde{R}} \times 2^{-r(1+\epsilon)\mathbb{H}(Z)}} + \frac{2^{-r(1-\epsilon)\mathbb{H}(Z|U)}}{2^{r(R+R_t+R_k)} \times 2^{-r(1+\epsilon)\mathbb{H}(Z)}} + 1 \right) \quad (199)$$

$$\begin{aligned} \Psi_2 &= \sum_{(k_{j-1}, t_j, k_j)} \sum_{m_j} \sum_{t_{j-1}} \sum_{k_{j-2}} \sum_{\ell_j} \frac{1}{2^{r(R+R_t+2R_k+\tilde{R}+R_T+R_K)}} \sum_{\substack{(u^r(m_j, t_{j-1}, k_{j-2}), v^r(\ell_j), z_j^r) \\ (u^r(m_j, t_{j-1}, k_{j-2}), v^r(\ell_j), z_j^r) \notin \mathcal{T}_\epsilon^{(r)}}} \Gamma_{U^r, V^r, Z_j^r}^{(\mathcal{C}_r)}(u^r(m_j, t_{j-1}, k_{j-2}), v^r(\ell_j), z_j^r) \\ &\times \log \left(\frac{W_{Z|U,V}^{\otimes r}(z_j^r | u^r(m_j, t_{j-1}, k_{j-2}), v^r(\ell_j))}{2^{r(R+R_t+R_k+\tilde{R}-R_T-R_K)} Q_Z^{\otimes r}(z_j^r)} + \frac{W_{Z|V}^{\otimes r}(z_j^r | v^r(\ell_j))}{2^{r(\tilde{R}-R_T-R_K)} Q_Z^{\otimes r}(z_j^r)} + \frac{W_{Z|U}^{\otimes r}(z_j^r | u^r(m_j, t_{j-1}, k_{j-2}))}{2^{r(R+R_t+R_k)} Q_Z^{\otimes r}(z_j^r)} + 1 \right) \\ &\leq 2|V||U||Z|e^{-r\epsilon^2\mu_{V,U,Z}r} \log \left(\frac{3}{\mu_Z} + 1 \right). \end{aligned} \quad (200)$$

In (200) $\mu_{V,U,Z} = \min_{(v,u,z) \in (\mathcal{V}, \mathcal{U}, \mathcal{Z})} P_{V,U,Z}(v, u, z)$ and $\mu_Z = \min_{z \in \mathcal{Z}} P_Z(z)$. When $r \rightarrow \infty$ then $\Psi_2 \rightarrow 0$ and Ψ_1 goes to zero when r grows if

$$R + R_t + R_k + \tilde{R} - R_T - R_K > \mathbb{I}(U, V; Z), \quad (201a)$$

$$\tilde{R} - R_T - R_K > \mathbb{I}(V; Z), \quad (201b)$$

$$R + R_t + R_k > \mathbb{I}(U; Z). \quad (201c)$$

Decoding and Error Probability Analysis: At the end of block $j \in \llbracket 1 : B \rrbracket$, using its knowledge of the key k_{j-2} generated from the block $j-2$, the receiver finds a unique pair $(\hat{m}_j, \hat{t}_{j-1})$ such that $(u^r(\hat{m}_j, \hat{t}_{j-1}, k_{j-2}), y_j^r) \in \mathcal{T}_\epsilon^{(r)}$. According to the law of large numbers and the packing lemma probability of error vanishes when r grows if [31],

$$R + R_t < \mathbb{I}(U; Y). \quad (202)$$

We now analyze the probability of error at the encoder and the decoder for key generation. Let (L_{j-1}, T_{j-1}) denote the chosen indices at the encoder and \hat{L}_{j-1} and \hat{T}_{j-1} be the estimate of the index L_{j-1} and T_{j-1} at the decoder. At the end of block j , by decoding U_j^r , the receiver has access to T_{j-1} and to find L_{j-1} we define the error event,

$$\mathcal{E} = \left\{ (V_{j-1}^r(\hat{L}_{j-1}), S_{j-1}^r, U_{j-1}^r, Y_{j-1}^r) \notin \mathcal{T}_\epsilon^{(n)} \right\}, \quad (203)$$

and consider the events,

$$\mathcal{E}_1 = \left\{ (V_{j-1}^r(\ell_{j-1}), S_{j-1}^r) \notin \mathcal{T}_{\epsilon'}^{(n)} \text{ for all } \ell_{j-1} \in \llbracket 1 : 2^{r\tilde{R}} \rrbracket \right\}, \quad (204a)$$

$$\mathcal{E}_2 = \left\{ (V_{j-1}^r(L_{j-1}), S_{j-1}^r, U_{j-1}^r, Y_{j-1}^r) \notin \mathcal{T}_\epsilon^{(n)} \right\}, \quad (204b)$$

$$\mathcal{E}_3 = \left\{ (V_{j-1}^r(\tilde{\ell}_{j-1}), U_{j-1}^r, Y_{j-1}^r) \in \mathcal{T}_\epsilon^{(n)} \text{ for some } \ell_{j-1} \in \mathcal{B}(T_{j-1}), \tilde{\ell}_{j-1} \neq \ell_{j-1} \right\}, \quad (204c)$$

where $\epsilon > \epsilon' > 0$. By the union bound we have,

$$P(\mathcal{E}) \leq P(\mathcal{E}_1) + P(\mathcal{E}_1^c \cap \mathcal{E}_2) + P(\mathcal{E}_3). \quad (205)$$

Similar to the proof of Lemma 2 one can show that the first term on the RHS of (205) vanishes when r grows if we have (196). Following the steps in [31, Sec. 11.3.1], the last two terms on the RHS of (205) go to zero when r grows if,

$$\tilde{R} > \mathbb{I}(S; V), \quad (206a)$$

$$\tilde{R} - R_t < \mathbb{I}(V; U, Y). \quad (206b)$$

Applying Fourier-Motzkin to (196), (201), (202), and (206) and remarking that the scheme requires $R_t + R_k \leq R_T + R_K$ results in the achievable region in Theorem 7.

APPENDIX K
PROOF OF THEOREM 8

Fix $P_U(u)$, $x(u, s)$, and $\epsilon_1 > \epsilon_2 > 0$ such that, $P_Z = Q_0$.

Codebook Generation: Let $C_n \triangleq \{U^n(m)\}_{m \in \mathcal{M}}$, where $\mathcal{M} \in \llbracket 1 : 2^{nR} \rrbracket$, be a random codebook consisting of independent random sequences each generated according to $\prod_{i=1}^n P_U(u_i)$. We denote a realization of C_n by $\mathcal{C}_n \triangleq \{u^n(m)\}_{m \in \mathcal{M}}$.

Encoding: To send the message m the encoder computes $u^n(m)$ and transmits codeword x^n , where $x_i = x(u_i(m), s_i)$. For a fixed codebook \mathcal{C}_n , the induced joint distribution over the codebook is as follows

$$P_{M,S^n,U^n,Z^n}^{(\mathcal{C}_n)}(m, s^n, \tilde{u}^n, z^n) = 2^{-nR} Q_S^{\otimes n}(s^n) \mathbb{1}_{\{\tilde{u}^n = u^n(m)\}} W_{Z|U,S}^{\otimes n}(z^n | \tilde{u}^n, s^n). \quad (207)$$

Covert Analysis: We now show that this coding scheme guarantees that

$$\mathbb{E}_{C_n} [\mathbb{D}(P_{Z^n|C_n} || Q_Z^{\otimes n})] \xrightarrow{n \rightarrow \infty} 0, \quad (208)$$

where $P_{Z^n|C_n}$ is the marginal distribution of the distribution defined in (207) and is as follows

$$P_{Z^n|C_n}(z^n) = \sum_m \sum_{s^n} 2^{-nR} Q_S^{\otimes n}(s^n) W_{Z|U,S}^{\otimes n}(z^n | u^n(m), s^n) \quad (209)$$

$$= \sum_m 2^{-nR} W_{Z|U}^{\otimes n}(z^n | u^n(m)), \quad (210)$$

where $W_{Z|U} = \sum_{s \in \mathcal{S}} Q_S(s) W_{Z|U,S}(z|u, s)$. Then we choose P_U and $x(u, s)$ such that it satisfies $Q_Z = Q_0$. By [36, Theorem 1] one can show that (208) holds if,

$$R > \mathbb{I}(U; Z). \quad (211)$$

Decoding and Error Probability Analysis: Upon receiving y^n the receiver finds a unique message \hat{m} such that $(u^n(\hat{m}), y^n) \in \mathcal{T}_\epsilon^{(n)}$. According to the law of large numbers and the packing lemma probability of error vanishes when n grows if [31],

$$R < \mathbb{I}(U; Y). \quad (212)$$

APPENDIX L
PROOF OF THEOREM 9

Consider any sequence of length- n codes for a state-dependent channel with channel state available causally only at the transmitter such that $P_e^{(n)} \leq \epsilon_n$ and $\mathbb{D}(P_{Z^n} || Q_0^{\otimes n}) \leq \delta$ with $\lim_{n \rightarrow \infty} \epsilon_n = 0$. Note that the converse is consistent with the model and does *not* require δ to vanish.

A. *Epsilon Rate Region*

We first define a region \mathcal{S}_ϵ for $\epsilon > 0$ that expands the region defined in (37a) and (37b) as follows.

$$\mathcal{S}_\epsilon \triangleq \{R \geq 0 : \exists P_{U,V,S,X,Y,Z} \in \mathcal{D}_\epsilon : R \leq \mathbb{I}(U; Y) + \epsilon\} \quad (213a)$$

where

$$\mathcal{D}_\epsilon = \left\{ \begin{array}{l} P_{U,V,S,X,Y,Z} : \\ P_{U,V,S,X,Y,Z} = Q_S P_V P_{U|V} \mathbb{1}_{\{X=X(U,S)\}} W_{Y,Z|X,S} \\ \mathbb{D}(P_Z \| Q_0) \leq \epsilon \\ \mathbb{I}(U; Y) \geq \mathbb{I}(V; Z) - 3\epsilon \\ \max\{|\mathcal{U}|, |\mathcal{V}|\} \leq |\mathcal{X}| \end{array} \right\}, \quad (213b)$$

where $\epsilon \triangleq \max\{\epsilon_n, \nu \geq \frac{\delta}{n}\}$. We next show that if a rate R is achievable then $R \in \mathcal{S}_\epsilon$ for any $\epsilon > 0$.

For any $\epsilon_n > 0$, we start by upper bounding nR using standard techniques.

$$\begin{aligned} nR &= \mathbb{H}(M) \\ &\stackrel{(a)}{\leq} \mathbb{I}(M; Y^n) + n\epsilon_n \\ &= \sum_{i=1}^n \mathbb{I}(M; Y_i | Y^{i-1}) + n\epsilon_n \\ &\leq \sum_{i=1}^n \mathbb{I}(M, Y^{i-1}; Y_i) + n\epsilon_n \\ &\stackrel{(b)}{\leq} \sum_{i=1}^n \mathbb{I}(M, S^{i-1}; Y_i) + n\epsilon_n \\ &\stackrel{(c)}{=} \sum_{i=1}^n \mathbb{I}(U_i; Y_i) + n\epsilon_n \\ &= n \sum_{i=1}^n \frac{1}{n} \mathbb{I}(U_i; Y_i) + n\epsilon_n \\ &= n \sum_{i=1}^n \mathbb{P}(T = i) \mathbb{I}(U_i; Y_i | T = i) + n\epsilon_n \\ &= n \mathbb{I}(U_T; Y_T | T) + n\epsilon_n \\ &\leq n \mathbb{I}(U_T, T; Y_T) + n\epsilon_n \\ &\stackrel{(d)}{=} n \mathbb{I}(U; Y) + n\epsilon_n \\ &\stackrel{(e)}{\leq} n \mathbb{I}(U; Y) + n\epsilon, \end{aligned} \quad (214)$$

where

- (a) follows from Fano's inequality;
- (b) follows since $(M, Y^{i-1}) - (M, S^{i-1}) - Y_i$, note that we also have $V_i - (M, S^{i-1}) - Y_i$, where $V_i \triangleq (M, Z^{i-1})$;
- (c) follows by defining $U_i \triangleq (M, S^{i-1})$;
- (d) follows by defining $U = (U_T, T)$ and $Y = Y_T$;
- (e) follows by defining $\epsilon \triangleq \max\{\epsilon_n, \nu \geq \frac{\delta}{n}\}$.

Next, we lower bound nR as follows,

$$\begin{aligned} nR &\geq \mathbb{H}(M) \\ &\geq \mathbb{I}(M; Z^n) \end{aligned}$$

$$\begin{aligned}
&= \sum_{i=1}^n \mathbb{I}(M; Z_i | Z^{i-1}) \\
&\stackrel{(a)}{\geq} \sum_{i=1}^n \mathbb{I}(M, Z^{i-1}; Z_i) - \delta \\
&\stackrel{(b)}{=} \sum_{i=1}^n \mathbb{I}(V_i; Z_i) - \delta \\
&= n \sum_{i=1}^n \mathbb{P}(T = i) \mathbb{I}(V_i; Z_i | T = i) - \delta \\
&= n \mathbb{I}(V_T; Z_T | T) - \delta \\
&\stackrel{(c)}{\geq} n \mathbb{I}(V_T, T; Z_T) - 2\delta \\
&\stackrel{(d)}{=} n \mathbb{I}(V; Z) - 2\delta \tag{215}
\end{aligned}$$

where

- (a) follows from Lemma 3;
- (b) follows from the definition of $V_i \triangleq (M, Z^{i-1})$, which is defined in the process of deriving (214);
- (c) follows from Lemma 3;
- (d) follows by defining $V = (V_T, T)$ and $Z = Z_T$.

For any $\nu > 0$, choosing n large enough ensures that

$$\begin{aligned}
R &\geq \mathbb{I}(V; Z) - 2\nu \\
&\geq \mathbb{I}(V; Z) - 2\epsilon, \tag{216}
\end{aligned}$$

where the last equality follows from definition $\epsilon \triangleq \max\{\epsilon_n, \nu\}$. To show that $\mathbb{D}(P_Z || Q_0) \leq \epsilon$, note that for n large enough

$$\mathbb{D}(P_Z || Q_0) = \mathbb{D}(P_{Z_T} || Q_0) = \mathbb{D}\left(\frac{1}{n} \sum_{i=1}^n P_{Z_i} \middle| \middle| Q_0\right) \leq \frac{1}{n} \sum_{i=1}^n \mathbb{D}(P_{Z_i} || Q_0) \leq \frac{1}{n} \mathbb{D}(P_{Z^n} || Q_0^{\otimes n}) \leq \frac{\delta}{n} \leq \nu \leq \epsilon. \tag{217}$$

Combining (214) and (216), and (217) shows that $\forall \epsilon_n, \nu > 0$, $R \leq \max\{x : x \in \mathcal{S}_\epsilon\}$. Therefore,

$$R \leq \max \left\{ x : x \in \bigcap_{\epsilon > 0} \mathcal{S}_\epsilon \right\}. \tag{218}$$

1) *Continuity at Zero*: One can prove the continuity at zero of \mathcal{S}_ϵ by substituting $\min\{\mathbb{I}(U; Y) - \mathbb{I}(U; S), \mathbb{I}(U, V; Y) - \mathbb{I}(U; S|V)\}$ with $\mathbb{I}(U; Y)$ and $\mathbb{I}(V; Z) - \mathbb{I}(V; S)$ with $\mathbb{I}(V; Z)$ in Appendix I and following the exact same arguments.

APPENDIX M

PROOF OF THEOREM 10

We adopt a block-Markov encoding scheme in which B independent messages are transmitted over B channel blocks each of length r , such that $n = rB$. The warden's observation is $Z^n = (Z_1^r, \dots, Z_B^r)$, the distribution induced at the output of the warden is P_{Z^n} , the target output distribution is $Q_Z^{\otimes n}$, and Equation (81), describing the distance between the two distributions, continues to hold. The random code generation is as follows:

Fix $P_X(x)$, $P_{V|S}(v|s)$, and $\epsilon_1 > \epsilon_2 > 0$ such that, $P_Z = Q_0$.

Codebook Generation for Keys: For each block $j \in \llbracket 1 : B \rrbracket$, let $C_1^{(r)} \triangleq \{V^r(\ell_j)\}_{\ell_j \in \mathcal{L}}$, where $\mathcal{L} = \llbracket 1 : 2^{r\tilde{R}} \rrbracket$, be a random codebook consisting of independent random sequences each generated according to $P_V^{\otimes r}$, where $P_V = \sum_{s \in \mathcal{S}} Q_S(s) P_{V|S}(v|s)$. We denote a realization of $C_1^{(r)}$ by $\mathcal{C}_1^{(r)} \triangleq \{v^r(\ell_j)\}_{\ell_j \in \mathcal{L}}$. Partition the set of indices $\ell_j \in \llbracket 1 : 2^{r\tilde{R}} \rrbracket$ into bins $\mathcal{B}(t)$, $t \in \llbracket 1 : 2^{rR_t} \rrbracket$ by using function $\varphi : V^r(\ell_j) \rightarrow \llbracket 1 : 2^{rR_t} \rrbracket$ through random binning by choosing the value of $\varphi(v^r(\ell_j))$ independently and uniformly at random for every $v^r(\ell_j) \in \mathcal{V}^r$. For each block $j \in \llbracket 1 : B \rrbracket$, create a function $\Phi : V^r(\ell_j) \rightarrow \llbracket 1 : 2^{rR_k} \rrbracket$ through random binning by choosing the value of $\Phi(v^r(\ell_j))$ independently and uniformly at random for every $v^r(\ell_j) \in \mathcal{V}^r$. The key $k_j = \Phi(v^r(\ell_j))$ obtained in block $j \in \llbracket 1 : B \rrbracket$ from the description of the channel state sequence $v^r(\ell_j)$ is used to assist the encoder in block $j + 2$.

Codebook Generation for Messages: For each block $j \in \llbracket 1 : B \rrbracket$, let $C_2^{(r)} \triangleq \{X^r(m_j, t_{j-1}, k_{j-2})\}_{(m_j, t_{j-1}, k_{j-2}) \in \mathcal{M} \times \mathcal{T} \times \mathcal{K}}$, where $\mathcal{M} = \llbracket 1 : 2^{rR} \rrbracket$, $\mathcal{T} = \llbracket 1 : 2^{rR_t} \rrbracket$, and $\mathcal{K} = \llbracket 1 : 2^{rR_k} \rrbracket$, be a random codebook consisting of independent random sequences each generated according to $P_X^{\otimes r}$. We denote a realization of $C_2^{(r)}$ by $\mathcal{C}_2^{(r)} \triangleq \{x^r(m_j, t_{j-1}, k_{j-2})\}_{(m_j, t_{j-1}, k_{j-2}) \in \mathcal{M} \times \mathcal{T} \times \mathcal{K}}$. Let, $C_r = \{C_1^{(r)}, C_2^{(r)}\}$ and $\mathcal{C}_r = \{\mathcal{C}_1^{(r)}, \mathcal{C}_2^{(r)}\}$. The indices (m_j, t_{j-1}, k_{j-2}) can be viewed as a two layer binning. We define an ideal PMF for codebook \mathcal{C}_r , as an approximate distribution to facilitate the analysis

$$\begin{aligned} & \Gamma_{M_j, T_{j-1}, K_{j-2}, L_j, X^r, V^r, S_j^r, Z_j^r, K_{j-1}, T_j, K_j}^{(C_r)}(m_j, t_{j-1}, k_{j-2}, \ell_j, \tilde{x}^r, \tilde{v}^r, s_j^r, z_j^r, k_{j-1}, t_j, k_j) \\ &= 2^{-r(R+R_t+R_k+\tilde{R})} \mathbb{1}_{\{\tilde{x}^r = x^r(m_j, t_{j-1}, k_{j-2})\}} \mathbb{1}_{\{\tilde{v}^r = v^r(\ell_j)\}} P_{S|V}^{\otimes r}(s_j^r | \tilde{v}^r) W_{Z|X, S}^{\otimes r}(z_j^r | \tilde{x}^r, s_j^r) \\ & \quad \times 2^{-rR_k} \mathbb{1}_{\{t_j = \varphi(\tilde{v}^r)\}} \mathbb{1}_{\{k_j = \Phi(\tilde{v}^r)\}}, \end{aligned} \quad (219)$$

where $W_{Z|X, S}$ is the marginal distribution of $W_{Y, Z|X, S}$ defined in Theorem 10 and

$$P_{S|V} = \frac{P_{S, V}(s, v)}{P_V(v)} = \frac{Q_S(s) P_{V|S}(v|s)}{\sum_{s \in \mathcal{S}} Q_S(s) P_{V|S}(v|s)}. \quad (220)$$

Encoding: We assume that the transmitter and the receiver have access to shared secret keys k_{-1} and k_0 for the first two blocks but after the first two blocks they use the key that they generate from the CSI.

In the first block, to send the message m_1 according to k_{-1} , the encoder chooses the index t_0 uniformly at random (the index t_0 does not carry any useful information) and computes $x^r(m_1, t_0, k_{-1})$ and transmits it over the channel.

At the beginning of the second block, to generate a secret key shared between the transmitter and the receiver, the encoder chooses the index ℓ_1 according to the following distribution with $j = 1$,

$$f(\ell_j | s_j^r) = \frac{P_{S|V}^{\otimes r}(s_j^r | v^r(\ell_j))}{\sum_{\ell' \in \llbracket 1 : 2^{r\tilde{R}} \rrbracket} P_{S|V}^{\otimes r}(s_j^r | v^r(\ell'))}, \quad (221)$$

where $P_{S|V}$ is defined in (220). Then generates the reconciliation index $t_1 = \varphi(v^r(\ell_1))$; simultaneously the transmitter generates a key $k_1 = \Phi(v^r(\ell_1))$ from the description of its CSI of the first block $v^r(\ell_1)$ to be used in the next block. To transmit the message m_2 and reconciliation index t_1 according to the key k_0 the encoder computes $x^r(m_2, t_1, k_0)$ and transmits it over the channel.

In block $j \in \llbracket 3 : B \rrbracket$, the encoder first selects the index ℓ_{j-1} based s_{j-1}^r by using the likelihood encoder described in (221) and then generates the reconciliation index $t_{j-1} = \varphi(v^r(\ell_{j-1}))$; simultaneously the transmitter generates a key $k_{j-1} = \Phi(v^r(\ell_{j-1}))$ from the description of its CSI of the block $j - 1$, $v^r(\ell_{j-1})$, to be used in the next block. Then to send the message m_j and the reconciliation index t_{j-1} according to the generated key k_{j-2} from the previous block, the encoder computes $x^r(m_j, t_{j-1}, k_{j-2})$ and transmits it over the channel.

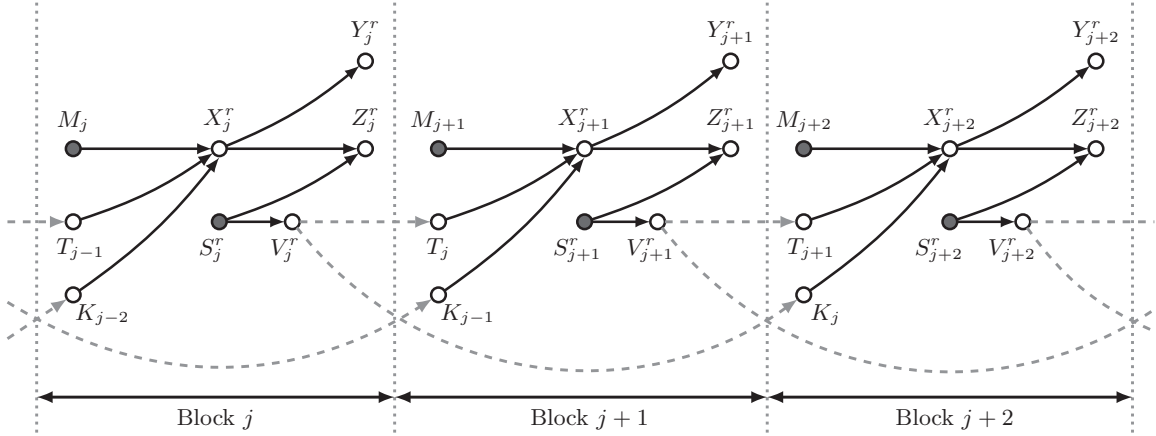

Fig. 13. Functional dependence graph for the block-Markov encoding scheme

Define

$$\begin{aligned}
& \Upsilon_{M_j, T_{j-1}, K_{j-2}, X^r, S_j^r, L_j, V^r, Z_j^r, K_{j-1}, T_j, K_j}^{(C_r)}(m_j, t_{j-1}, k_{j-2}, \tilde{x}^r, s_j^r, \ell_j, v^r, z_j^r, k_{j-1}, t_j, k_j) \\
& \triangleq 2^{-r(R+R_t+R_k)} \mathbb{1}_{\{\tilde{x}^r = x^r(m_j, t_{j-1}, k_{j-2})\}} Q_S^{\otimes r}(s_j^r) f(\ell_j | s_j^r) \mathbb{1}_{\{v^r = v^r(\ell_j)\}} \\
& \quad \times W_{Z|X, S}^{\otimes r}(z_j^r | \tilde{x}^r, s_j^r) 2^{-rR_k} \mathbb{1}_{\{t_j = \sigma(v^r(\ell_j))\}} \mathbb{1}_{\{k_j = \Phi(v^r(\ell_j))\}}. \tag{222}
\end{aligned}$$

For a fixed codebook \mathcal{C}_r , the induced joint distribution over the codebook (i.e. $P^{(C_r)}$) satisfies

$$\mathbb{D}\left(P_{M_j, T_{j-1}, K_{j-2}, X^r, S_j^r, L_j, V^r, Z_j^r, K_{j-1}, T_j, K_j}^{(C_r)} \parallel \Upsilon_{M_j, T_{j-1}, K_{j-2}, X^r, S_j^r, L_j, V^r, Z_j^r, K_{j-1}, T_j, K_j}^{(C_r)}\right) \leq \epsilon. \tag{223}$$

This intermediate distribution $\Upsilon^{(C_r)}$ approximates the true distribution $P^{(C_r)}$ and will be used in the sequel for bounding purposes. Expression (223) holds because the main difference in $\Upsilon^{(C_r)}$ is assuming the keys K_{j-2} , K_{j-1} and the reconciliation index T_{j-1} are uniformly distributed, which is made (arbitrarily) nearly uniform in $P^{(C_r)}$ with appropriate control of rate.

Covert Analysis: We now show that this coding scheme guarantees that $\mathbb{E}_{C_n} [\mathbb{D}(P_{Z^n|C_n} \parallel Q_Z^{\otimes n})] \xrightarrow{n \rightarrow \infty} 0$, where C_n is the set of all the codebooks for all blocks, and then choose P_X and P_V such that it satisfies $Q_Z = Q_0$. Similar to (137) by using functional dependence graph depicted in Fig. 13 one can show that

$$\mathbb{D}(P_{Z^n} \parallel Q_Z^{\otimes n}) \leq 2 \sum_{j=1}^B \mathbb{D}(P_{Z_j^r, K_{j-1}, T_j, K_j} \parallel Q_Z^{\otimes r} Q_{K_{j-1}} Q_{T_j} Q_{K_j}). \tag{224}$$

To bound the RHS of (224) by using Lemma 1 and the triangle inequality we have,

$$\begin{aligned}
& \mathbb{E}_{C_r} \|P_{Z_j^r, K_{j-1}, T_j, K_j|C_r} - Q_Z^{\otimes r} Q_{K_{j-1}} Q_{T_j} Q_{K_j}\|_1 \\
& \leq \mathbb{E}_{C_r} \|P_{Z_j^r, K_{j-1}, T_j, K_j|C_r} - \Gamma_{Z_j^r, K_{j-1}, T_j, K_j|C_r}\|_1 + \mathbb{E}_{C_r} \|\Gamma_{Z_j^r, K_{j-1}, T_j, K_j|C_r} - Q_Z^{\otimes r} Q_{K_{j-1}} Q_{T_j} Q_{K_j}\|_1 \\
& \leq \mathbb{E}_{C_r} \|P_{Z_j^r, K_{j-1}, T_j, K_j|C_r} - \Upsilon_{Z_j^r, K_{j-1}, T_j, K_j|C_r}\|_1 + \mathbb{E}_{C_r} \|\Upsilon_{Z_j^r, K_{j-1}, T_j, K_j|C_r} - \Gamma_{Z_j^r, K_{j-1}, T_j, K_j|C_r}\|_1 \\
& \quad + \mathbb{E}_{C_r} \|\Gamma_{Z_j^r, K_{j-1}, T_j, K_j|C_r} - Q_Z^{\otimes r} Q_{K_{j-1}} Q_{T_j} Q_{K_j}\|_1. \tag{225}
\end{aligned}$$

From (223) and the monotonicity of KL-divergence the first term on the RHS of (225) goes to zero when n grows.

To bound the second term on the RHS of (225) for a fixed codebook \mathcal{C}_r we have,

$$\Gamma_{M_j, T_{j-1}, K_{j-2}}^{(C_r)} = 2^{-r(R+R_t+R_k)} = \Upsilon_{M_j, T_{j-1}, K_{j-2}}^{(C_r)}, \tag{226a}$$

$$\Gamma_{X^r|M_j, T_{j-1}, K_{j-2}, S_j^r}^{(C_r)} = \mathbb{1}_{\{\tilde{x}^r = x^r(m_j, t_{j-1}, k_{j-2})\}} = \Upsilon_{X^r|M_j, T_{j-1}, K_{j-2}, S_j^r}^{(C_r)}, \quad (226b)$$

$$\Gamma_{L_j|M_j, T_{j-1}, K_{j-2}, S_j^r, X^r}^{(C_r)} = f(\ell_j | s_j^r) = \Upsilon_{L_j|M_j, T_{j-1}, K_{j-2}, S_j^r, X^r}^{(C_r)}, \quad (226c)$$

$$\Gamma_{V^r|M_j, T_{j-1}, K_{j-2}, S_j^r, L_j, X^r}^{(C_r)} = \mathbb{1}_{\{\tilde{v}^r = v^r(\ell_j)\}} = \Upsilon_{V^r|M_j, T_{j-1}, K_{j-2}, S_j^r, L_j, X^r}^{(C_r)}, \quad (226d)$$

$$\Gamma_{Z_j^r|M_j, T_{j-1}, K_{j-2}, S_j^r, L_j, X^r, V^r}^{(C_r)} = W_{Z|X, S}^{\otimes r} = \Upsilon_{Z_j^r|M_j, T_{j-1}, K_{j-2}, S_j^r, L_j, X^r, V^r}^{(C_r)}, \quad (226e)$$

$$\Gamma_{K_{j-1}|M_j, T_{j-1}, K_{j-2}, S_j^r, L_j, X^r, V^r, Z_j^r}^{(C_r)} = 2^{-rR_k} = \Upsilon_{K_{j-1}|M_j, T_{j-1}, K_{j-2}, S_j^r, L_j, X^r, V^r, Z_j^r}^{(C_r)}, \quad (226f)$$

$$\Gamma_{T_j|M_j, T_{j-1}, K_{j-2}, S_j^r, L_j, X^r, V^r, Z_j^r}^{(C_r)} = \mathbb{1}_{\{t_j = \sigma(v^r(\ell_j))\}} = \Upsilon_{T_j|M_j, T_{j-1}, K_{j-2}, S_j^r, L_j, X^r, V^r, Z_j^r}^{(C_r)}, \quad (226g)$$

$$\Gamma_{K_j|M_j, T_{j-1}, K_{j-2}, S_j^r, L_j, X^r, V^r, Z_j^r, T_j}^{(C_r)} = \mathbb{1}_{\{k_j = \Phi(v^r(\ell_j))\}} = \Upsilon_{K_j|M_j, T_{j-1}, K_{j-2}, S_j^r, L_j, X^r, V^r, Z_j^r, T_j}^{(C_r)}, \quad (226h)$$

where (226c) follows from (221). Hence,

$$\begin{aligned} & \mathbb{E}_{C_r} \|\Upsilon_{Z_j^r, K_{j-1}, T_j, K_j|C_r} - \Gamma_{Z_j^r, K_{j-1}, T_j, K_j}\|_1 \\ & \leq \mathbb{E}_{C_r} \|\Upsilon_{M_j, T_{j-1}, K_{j-2}, S_j^r, L_j, X^r, V^r, Z_j^r, K_{j-1}, T_j, K_j|C_r} - \Gamma_{M_j, T_{j-1}, K_{j-2}, S_j^r, L_j, X^r, V^r, Z_j^r, K_{j-1}, T_j, K_j|C_r}\|_1 \\ & \stackrel{(a)}{=} \mathbb{E}_{C_r} \|\Upsilon_{M_j, T_{j-1}, K_{j-2}, S_j^r|C_r} - \Gamma_{M_j, T_{j-1}, K_{j-2}, S_j^r|C_r}\|_1 \\ & \stackrel{(b)}{=} \mathbb{E}_{C_r} \|Q_S^{\otimes r} - \Gamma_{S_j^r|M_j=1, T_{j-1}=1, K_{j-2}=1, C_r}\|_1, \end{aligned} \quad (227)$$

where (a) follows from (226b)-(226h) and (b) follows from the symmetry of the codebook construction with respect to M_j , T_{j-1} , and K_{j-2} and (226a). Based on the soft covering lemma [26, Corollary VII.5] the RHS of (227) vanishes if

$$\tilde{R} > \mathbb{I}(S; V). \quad (228)$$

We now proceed to bound the third term on the RHS of (225). First, consider the marginal

$$\begin{aligned} \Gamma_{Z_j^r, K_{j-1}, T_j, K_j|C_r}(z_j^r, k_{j-1}, t_j, k_j) &= \sum_{m_j} \sum_{t_{j-1}} \sum_{k_{j-2}} \sum_{\ell_j} \sum_{s_j^r} \frac{1}{2^{r(R+R_t+R_k+\tilde{R})}} P_{S|V}^{\otimes r}(s_j^r | V^r(\ell_j)) \\ & \times W_{Z|X, S}^{\otimes r}(z_j^r | X^r(m_j, t_{j-1}, k_{j-2}), s_j^r) 2^{-rR_k} \mathbb{1}_{\{t_j = \sigma(V^r(\ell_j))\}} \mathbb{1}_{\{k_j = \Phi(V^r(\ell_j))\}} \\ & = \sum_{m_j} \sum_{t_{j-1}} \sum_{k_{j-2}} \sum_{\ell_j} \frac{1}{2^{r(R+R_t+R_k+\tilde{R})}} W_{Z|X, V}^{\otimes r}(z_j^r | X^r(m_j, t_{j-1}, k_{j-2}), V^r(\ell_j)) 2^{-rR_k} \mathbb{1}_{\{t_j = \sigma(V^r(\ell_j))\}} \mathbb{1}_{\{k_j = \Phi(V^r(\ell_j))\}}, \end{aligned} \quad (229)$$

where $W_{Z|X, V}(z|x, v) = \sum_{s \in S} P_{S|V}(s|v) W_{Z|X, V}(z|x, v)$. To bound the third term on the RHS of (225) by using Pinsker's inequality, it is sufficient to bound $\mathbb{E}_{C_r} [\mathbb{D}(\Gamma_{Z_j^r, K_{j-1}, T_j, K_j|C_r} \| Q_Z^{\otimes r} Q_{K_{j-1}} Q_{T_j} Q_{K_j})]$ as follows,

$$\begin{aligned} & \mathbb{E}_{C_r} [\mathbb{D}(\Gamma_{Z_j^r, K_{j-1}, T_j, K_j|C_r} \| Q_Z^{\otimes r} Q_{K_{j-1}} Q_{T_j} Q_{K_j})] \\ & = \mathbb{E}_{C_r} \left[\sum_{z_j^r, k_{j-1}, t_j, k_j} \Gamma_{Z_j^r, K_{j-1}, T_j, K_j|C_r}(z_j^r, k_{j-1}, t_j, k_j) \log \left(\frac{\Gamma_{Z_j^r, K_{j-1}, T_j, K_j|C_r}(z_j^r, k_{j-1}, t_j, k_j)}{Q_Z^{\otimes r}(z_j^r) Q_{K_{j-1}}(k_{j-1}) Q_{T_j}(t_j) Q_{K_j}(k_j)} \right) \right] \\ & = \mathbb{E}_{C_r} \left[\sum_{(z_j^r, k_{j-1}, t_j, k_j)} \sum_{m_j} \sum_{t_{j-1}} \sum_{k_{j-2}} \sum_{\ell_j} \frac{1}{2^{r(R+R_t+2R_k+\tilde{R})}} W_{Z|X, V}^{\otimes r}(z_j^r | X^r(m_j, t_{j-1}, k_{j-2}), V^r(\ell_j)) \right. \\ & \times \mathbb{1}_{\{t_j = \varphi(V^r(\ell_j))\}} \mathbb{1}_{\{k_j = \Phi(V^r(\ell_j))\}} \\ & \left. \times \log \left(\frac{\sum_{\tilde{m}_j} \sum_{\tilde{t}_{j-1}} \sum_{\tilde{k}_{j-2}} \sum_{\tilde{\ell}_j} W_{Z|X, V}^{\otimes r}(z_j^r | X^r(\tilde{m}_j, \tilde{t}_{j-1}, \tilde{k}_{j-2}), V^r(\tilde{\ell}_j)) \mathbb{1}_{\{t_j = \varphi(V^r(\tilde{\ell}_j))\}} \mathbb{1}_{\{k_j = \Phi(V^r(\tilde{\ell}_j))\}}}{2^{r(R+R_t+R_k+\tilde{R}-R_T-R_K)} Q_Z^{\otimes r}(z_j^r)} \right) \right] \end{aligned}$$

$$\begin{aligned}
&\stackrel{(a)}{\leq} \sum_{(z_j^r, k_{j-1}, t_j, k_j)} \sum_{m_j} \sum_{t_{j-1}} \sum_{k_{j-2}} \sum_{\ell_j} \frac{1}{2^{r(R+R_t+2R_k+\tilde{R})}} \sum_{(x^r(m_j, t_{j-1}, k_{j-2}), s_j^r, v^r(\ell_j))} \Gamma_{X^r, S_j^r, V^r, Z_j^r}^{(C_r)}(x^r(m_j, t_{j-1}, k_{j-2}), s_j^r, v^r(\ell_j), z_j^r) \\
&\times \mathbb{E}_{\varphi(v^r(\ell_j))} [\mathbb{1}_{\{t_j=\varphi(v^r(\ell_j))\}}] \times \mathbb{E}_{\Phi(v^r(\ell_j))} [\mathbb{1}_{\{k_j=\Phi(v^r(\ell_j))\}}] \\
&\times \log \mathbb{E}_{\substack{(m_j, t_{j-1}, k_{j-2}, \ell_j), \\ \setminus (\varphi(v^r(\ell_j)), \Phi(v^r(\ell_j)))}} \left[\frac{\sum_{\tilde{m}_j} \sum_{\tilde{t}_{j-1}} \sum_{\tilde{k}_{j-2}} \sum_{\tilde{\ell}_j} W_{Z|X, V}^{\otimes r}(z_j^r | X^r(\tilde{m}_j, \tilde{t}_{j-1}, \tilde{k}_{j-2}), V^r(\tilde{\ell}_j)) \mathbb{1}_{\{t_j=\varphi(V^r(\tilde{\ell}_j))\}} \mathbb{1}_{\{k_j=\Phi(V^r(\tilde{\ell}_j))\}}}{2^{r(R+R_t+R_k+\tilde{R}-R_T-R_K)} Q_Z^{\otimes r}(z_j^r)} \right] \\
&\stackrel{(b)}{\leq} \sum_{(z_j^r, k_{j-1}, t_j, k_j)} \sum_{m_j} \sum_{t_{j-1}} \sum_{k_{j-2}} \sum_{\ell_j} \frac{1}{2^{r(R+R_t+2R_k+\tilde{R})}} \sum_{(x^r(m_j, t_{j-1}, k_{j-2}), s_j^r, v^r(\ell_j))} \Gamma_{X^r, S_j^r, V^r, Z_j^r}^{(C_r)}(x^r(m_j, t_{j-1}, k_{j-2}), s_j^r, v^r(\ell_j), z_j^r) \\
&\times \frac{1}{2^{r(R_T+R_K)}} \log \frac{1}{2^{r(R+R_t+R_k+\tilde{R}-R_T-R_K)} Q_Z^{\otimes r}(z_j^r)} \left(W_{Z|X, V}^{\otimes r}(z_j^r | x^r(m_j, t_{j-1}, k_{j-2}), v^r(\ell_j)) \right. \\
&+ \mathbb{E}_{\setminus (m_j, t_{j-1}, k_{j-2})} \left[\sum_{(\tilde{m}_j, \tilde{t}_{j-1}, \tilde{k}_{j-2}) \neq (m_j, t_{j-1}, k_{j-2})} W_{Z|X, V}^{\otimes r}(z_j^r | X^r(\tilde{m}_j, \tilde{t}_{j-1}, \tilde{k}_{j-2}), v^r(\ell_j)) \right] \\
&+ \mathbb{E}_{\setminus (\ell_j, \setminus (\varphi(v^r(\ell_j)), \Phi(v^r(\ell_j)))} \left[\sum_{\tilde{\ell}_j \neq \ell_j} W_{Z|X, V}^{\otimes r}(z_j^r | x^r(m_j, t_{j-1}, k_{j-2}), V^r(\tilde{\ell}_j)) \mathbb{1}_{\{t_j=\varphi(V^r(\tilde{\ell}_j))\}} \mathbb{1}_{\{k_j=\Phi(V^r(\tilde{\ell}_j))\}} \right] \\
&+ \mathbb{E}_{\setminus (m_j, t_{j-1}, k_{j-2}, \ell_j), \setminus (\varphi(v^r(\ell_j)), \Phi(v^r(\ell_j)))} \left[\sum_{\tilde{\ell}_j \neq \ell_j} \sum_{(\tilde{m}_j, \tilde{t}_{j-1}, \tilde{k}_{j-2}) \neq (m_j, t_{j-1}, k_{j-2})} W_{Z|X, V}^{\otimes r}(z_j^r | X^r(\tilde{m}_j, \tilde{t}_{j-1}, \tilde{k}_{j-2}), V^r(\tilde{\ell}_j)) \right. \\
&\left. \times \mathbb{1}_{\{t_j=\varphi(V^r(\tilde{\ell}_j))\}} \mathbb{1}_{\{k_j=\Phi(V^r(\tilde{\ell}_j))\}} \right] \Big) \\
&\stackrel{(c)}{\leq} \sum_{(z_j^r, k_{j-1}, t_j, k_j)} \sum_{m_j} \sum_{t_{j-1}} \sum_{k_{j-2}} \sum_{\ell_j} \frac{1}{2^{r(R+R_t+2R_k+\tilde{R})}} \sum_{(x^r(m_j, t_{j-1}, k_{j-2}), s_j^r, v^r(\ell_j))} \Gamma_{X^r, S_j^r, V^r, Z_j^r}^{(C_r)}(x^r(m_j, t_{j-1}, k_{j-2}), s_j^r, v^r(\ell_j), z_j^r) \\
&\times \frac{1}{2^{r(R_T+R_K)}} \log \left(\frac{W_{Z|X, V}^{\otimes r}(z_j^r | x^r(m_j, t_{j-1}, k_{j-2}), v^r(\ell_j))}{2^{r(R+R_t+R_k+\tilde{R}-R_T-R_K)} Q_Z^{\otimes r}(z_j^r)} \right. \\
&+ \sum_{(\tilde{m}_j, \tilde{t}_{j-1}, \tilde{k}_{j-2}) \neq (m_j, t_{j-1}, k_{j-2})} \frac{W_{Z|V}^{\otimes r}(z_j^r | v^r(\ell_j))}{2^{r(R+R_t+R_k+\tilde{R}-R_T-R_K)} Q_Z^{\otimes r}(z_j^r)} + \sum_{\tilde{\ell}_j \neq \ell_j} \frac{W_{Z|X}^{\otimes r}(z_j^r | x^r(m_j, t_{j-1}, k_{j-2}))}{2^{r(R+R_t+R_k+\tilde{R})} \times Q_Z^{\otimes r}(z_j^r)} + 1 \Big) \\
&\leq \sum_{(z_j^r, k_{j-1}, t_j, k_j)} \sum_{m_j} \sum_{t_{j-1}} \sum_{k_{j-2}} \sum_{\ell_j} \frac{1}{2^{r(R+R_t+2R_k+\tilde{R}+R_T+R_K)}} \sum_{(x^r(m_j, t_{j-1}, k_{j-2}), s_j^r, v^r(\ell_j))} \Gamma_{X^r, S_j^r, V^r, Z_j^r}^{(C_r)}(x^r(m_j, t_{j-1}, k_{j-2}), s_j^r, v^r(\ell_j), z_j^r) \\
&\times \log \left(\frac{W_{Z|X, V}^{\otimes r}(z_j^r | x^r(m_j, t_{j-1}, k_{j-2}), v^r(\ell_j))}{2^{r(R+R_t+R_k+\tilde{R}-R_T-R_K)} Q_Z^{\otimes r}(z_j^r)} + \frac{W_{Z|V}^{\otimes r}(z_j^r | v^r(\ell_j))}{2^{r(\tilde{R}-R_T-R_K)} Q_Z^{\otimes r}(z_j^r)} + \frac{W_{Z|X}^{\otimes r}(z_j^r | x^r(m_j, t_{j-1}, k_{j-2}))}{2^{r(R+R_t+R_k)} Q_Z^{\otimes r}(z_j^r)} + 1 \right) \\
&\triangleq \Psi_1 + \Psi_2, \tag{230}
\end{aligned}$$

where (a) follows from Jensen's inequality, (b) and (c) hold because $\mathbb{1}_{\{k_j=\Phi(s_j^r)\}} \leq 1$. We defined Ψ_1 and Ψ_2 as

$$\begin{aligned}
\Psi_1 &= \sum_{(k_{j-1}, t_j, k_j)} \sum_{m_j} \sum_{t_{j-1}} \sum_{k_{j-2}} \sum_{\ell_j} \frac{1}{2^{r(R+R_t+2R_k+R_T+R_K)}} \\
&\times \sum_{(v^r, x^r(m_j, t_{j-1}, k_{j-2}), z_j^r) \in \mathcal{T}_\epsilon^{(r)}} \Gamma_{V^r, X^r, Z^r}^{(C_r)}(v^r, x^r(m_j, t_{j-1}, k_{j-2}), z_j^r) \\
&\times \log \left(\frac{W_{Z|X, V}^{\otimes r}(z_j^r | x^r(m_j, t_{j-1}, k_{j-2}), v^r(\ell_j))}{2^{r(R+R_t+R_k+\tilde{R}-R_T-R_K)} Q_Z^{\otimes r}(z_j^r)} + \frac{W_{Z|V}^{\otimes r}(z_j^r | v^r(\ell_j))}{2^{r(\tilde{R}-R_T-R_K)} Q_Z^{\otimes r}(z_j^r)} + \frac{W_{Z|X}^{\otimes r}(z_j^r | x^r(m_j, t_{j-1}, k_{j-2}))}{2^{r(R+R_t+R_k)} Q_Z^{\otimes r}(z_j^r)} + 1 \right)
\end{aligned}$$

$$\leq \log \left(\frac{2^{r(R_T+R_K)} \times 2^{-r(1-\epsilon)\mathbb{H}(Z|X,V)}}{2^{r(R+R_t+R_k+\tilde{R})} \times 2^{-r(1+\epsilon)\mathbb{H}(Z)}} + \frac{2^{r(R_T+R_K)} \times 2^{-r(1-\epsilon)\mathbb{H}(Z|V)}}{2^{r\tilde{R}} \times 2^{-r(1+\epsilon)\mathbb{H}(Z)}} + \frac{2^{-r(1-\epsilon)\mathbb{H}(Z|X)}}{2^{r(R+R_t+R_k)} \times 2^{-r(1+\epsilon)\mathbb{H}(Z)}} + 1 \right) \quad (231)$$

$$\begin{aligned} \Psi_2 &= \sum_{(k_{j-1}, t_j, k_j)} \sum_{m_j} \sum_{t_{j-1}} \sum_{k_{j-2}} \sum_{\ell_j} \frac{1}{2^{r(R+R_t+2R_k+R_T+R_K)}} \\ &\quad \times \sum_{\substack{(v^r, x^r(m_j, t_{j-1}, k_{j-2}), z_j^r) \notin \mathcal{T}_\epsilon^{(r)} \\ (v^r, x^r(m_j, t_{j-1}, k_{j-2}), z_j^r) \in \mathcal{T}_\epsilon^{(r)}}} \Gamma_{V^r, X^r, Z^r}^{(C_r)}(v^r, x^r(m_j, t_{j-1}, k_{j-2}), z_j^r) \\ &\quad \times \log \left(\frac{W_{Z|X,V}^{\otimes r}(z_j^r | x^r(m_j, t_{j-1}, k_{j-2}), v^r(\ell_j))}{2^{r(R+R_t+R_k+\tilde{R}-R_T-R_K)} Q_Z^{\otimes r}(z_j^r)} + \frac{W_{Z|V}^{\otimes r}(z_j^r | v^r(\ell_j))}{2^{r(\tilde{R}-R_T-R_K)} Q_Z^{\otimes r}(z_j^r)} + \frac{W_{Z|X}^{\otimes r}(z_j^r | x^r(m_j, t_{j-1}, k_{j-2}))}{2^{r(R+R_t+R_k)} Q_Z^{\otimes r}(z_j^r)} + 1 \right) \\ &\leq 2|V||X||Z|e^{-r\epsilon^2\mu_{V,X,Z}} r \log \left(\frac{3}{\mu_Z} + 1 \right). \end{aligned} \quad (232)$$

In (232) $\mu_{X,V,Z} = \min_{(x,v,z) \in (\mathcal{X}, \mathcal{V}, \mathcal{Z})} P_{X,V,Z}(x,v,z)$ and $\mu_Z = \min_{z \in \mathcal{Z}} P_Z(z)$. When $r \rightarrow \infty$ then $\Psi_2 \rightarrow 0$ and Ψ_1 goes to zero when r grows if

$$R + R_t + R_k + \tilde{R} - R_T - R_K > \mathbb{I}(X, V; Z), \quad (233a)$$

$$\tilde{R} - R_T - R_K > \mathbb{I}(V; Z), \quad (233b)$$

$$R + R_t + R_k > \mathbb{I}(X; Z). \quad (233c)$$

Decoding and Error Probability Analysis: At the end of block $j \in \llbracket 1 : B \rrbracket$, using its knowledge of the key k_{j-2} generated from the block $j-2$, the receiver finds a unique pair $(\hat{m}_j, \hat{t}_{j-1})$ such that $(x^r(\hat{m}_j, \hat{t}_{j-1}, k_{j-2}), y_j^r) \in \mathcal{T}_\epsilon^{(r)}$. According to the law of large numbers and the packing lemma probability of error vanishes when r grows if [31],

$$R + R_t < \mathbb{I}(X; Y). \quad (234)$$

We now analyze the probability of error at the encoder and the decoder for key generation. Let (L_{j-1}, T_{j-1}) denote the chosen indices at the encoder and \hat{L}_{j-1} and \hat{T}_{j-1} be the estimate of the index L_{j-1} and T_{j-1} at the decoder. At the end of block j , by decoding U_j^r , the receiver has access to T_{j-1} and to find L_{j-1} we define the error event,

$$\mathcal{E} = \left\{ (V_{j-1}^r(\hat{L}_{j-1}), S_{j-1}^r, X_{j-1}^r, Y_{j-1}^r) \notin \mathcal{T}_\epsilon^{(n)} \right\}, \quad (235)$$

and consider the events

$$\mathcal{E}_1 = \left\{ (V_{j-1}^r(\ell_{j-1}), S_{j-1}^r) \notin \mathcal{T}_\epsilon^{(n)} \text{ for all } \ell_{j-1} \in \llbracket 1 : 2^{r\tilde{R}} \rrbracket \right\}, \quad (236a)$$

$$\mathcal{E}_2 = \left\{ (V_{j-1}^r(L_{j-1}), S_{j-1}^r, X_{j-1}^r, Y_{j-1}^r) \notin \mathcal{T}_\epsilon^{(n)} \right\}, \quad (236b)$$

$$\mathcal{E}_3 = \left\{ (V_{j-1}^r(\tilde{\ell}_{j-1}), X_{j-1}^r, Y_{j-1}^r) \in \mathcal{T}_\epsilon^{(n)} \text{ for some } \ell_{j-1} \in \mathcal{B}(T_{j-1}), \tilde{\ell}_{j-1} \neq \ell_{j-1} \right\}. \quad (236c)$$

By the union bound we have

$$P(\mathcal{E}) \leq P(\mathcal{E}_1) + P(\mathcal{E}_1^c \cap \mathcal{E}_2) + P(\mathcal{E}_3). \quad (237)$$

According to [37, Lemma 2] the first term on the RHS of (237) vanishes when r grows if we have (228). Following the steps in [31, Sec. 11.3.1], the last two terms on the right hand side of (237) go to zero when r grows if we have

$$\tilde{R} > \mathbb{I}(V; S), \quad (238a)$$

$$\tilde{R} - R_t < \mathbb{I}(V; X, Y). \quad (238b)$$

Applying Fourier-Motzkin to (228), (233), (234), and (238) and remarking that the scheme requires $R_t + R_k \leq R_T + R_K$ results in the region in Theorem 10.

APPENDIX N

PROOF OF THEOREM 11

Fix $P_X(x)$ and $\epsilon_1 > \epsilon_2 > 0$ such that, $P_Z = Q_0$.

Codebook Generation: Let $C_n \triangleq \{X^n(m)\}_{m \in \mathcal{M}}$, where $\mathcal{M} \in \llbracket 1 : 2^{nR} \rrbracket$, be a random codebook consisting of independent random sequences each generated according to $\prod_{i=1}^n P_X(x_i)$. We denote a realization of C_n by $\mathcal{C}_n \triangleq \{x^n(m)\}_{m \in \mathcal{M}}$.

Encoding: To send the message m the encoder computes $x^n(m)$ and transmits it over the channel.

For a fixed codebook \mathcal{C}_n , the induced joint distribution over the codebook is as follows

$$P_{M, S^n, X^n, Z^n}^{(\mathcal{C}_n)}(m, s^n, \tilde{x}^n, z^n) = 2^{-nR} Q_S^{\otimes n}(s^n) \mathbb{1}_{\{\tilde{x}^n = x^n(m)\}} W_{Z|X, S}^{\otimes n}(z^n | \tilde{x}^n, s^n). \quad (239)$$

Covert Analysis: We now show that this coding scheme guarantees that

$$\mathbb{E}_{\mathcal{C}_n} [\mathbb{D}(P_{Z^n | \mathcal{C}_n} || Q_Z^{\otimes n})] \xrightarrow[n \rightarrow \infty]{} 0, \quad (240)$$

where $P_{Z^n | \mathcal{C}_n}$ is the marginal distribution of the distribution induced by the code design defined in (239) and is as follows

$$P_{Z^n | \mathcal{C}_n}(z^n) = \sum_m \sum_{s^n} 2^{-nR} Q_S^{\otimes n}(s^n) W_{Z|X, S}^{\otimes n}(z^n | x^n(m), s^n) \quad (241)$$

$$= \sum_m 2^{-nR} W_{Z|X}^{\otimes n}(z^n | x^n(m)), \quad (242)$$

where $W_{Z|X} = \sum_{s \in \mathcal{S}} Q_S(s) W_{Z|X, S}(z|x, s)$. Then we choose P_X such that it satisfies $Q_Z = Q_0$.

By [36, Theorem 1] one can show that (240) holds if

$$R > \mathbb{I}(X; Z). \quad (243)$$

Decoding and Error Probability Analysis: Upon receiving y^n the receiver finds a unique message \hat{m} such that $(x^n(\hat{m}), y^n) \in \mathcal{T}_\epsilon^{(n)}$. According to the law of large numbers and the packing lemma probability of error vanishes when n grows if [31],

$$R < \mathbb{I}(X; Y). \quad (244)$$

APPENDIX O

PROOF OF THEOREM 12

Consider any sequence of length- n codes for a state-dependent channel with channel state available strictly causally only at the transmitter such that $P_e^{(n)} \leq \epsilon_n$ and $\mathbb{D}(P_{Z^n} || Q_0^{\otimes n}) \leq \delta$ with $\lim_{n \rightarrow \infty} \epsilon_n = 0$. Note that the converse is consistent with the model and does *not* require δ to vanish.

A. Epsilon Rate Region

We first define a region \mathcal{S}_ϵ for $\epsilon > 0$ that expands the region defined in (45a) and (45b) as follows.

$$\mathcal{S}_\epsilon \triangleq \{R \geq 0 : \exists P_{V,S,X,Y,Z} \in \mathcal{D}_\epsilon : R \leq \mathbb{I}(X;Y) + \epsilon\} \quad (245a)$$

where

$$\mathcal{D}_\epsilon = \left\{ \begin{array}{l} P_{V,S,X,Y,Z} : \\ P_{V,S,X,Y,Z} = Q_S P_V P_{X|V} W_{Y,Z|X,S} \\ \mathbb{D}(P_Z \| Q_0) \leq \epsilon \\ \mathbb{I}(X;Y) \geq \mathbb{I}(V;Z) - 3\epsilon \\ |\mathcal{V}| \leq |\mathcal{X}| \end{array} \right\}, \quad (245b)$$

where $\epsilon \triangleq \max\{\epsilon_n, \nu \geq \frac{\delta}{n}\}$. We next show that if a rate R is achievable then $R \in \mathcal{S}_\epsilon$ for any $\epsilon > 0$.

For any $\epsilon_n > 0$, we start by upper bounding nR using standard techniques.

$$\begin{aligned} nR &= \mathbb{H}(M) \\ &\stackrel{(a)}{\leq} \mathbb{I}(M; Y^n) + n\epsilon_n \\ &= \sum_{i=1}^n \mathbb{I}(M; Y_i | Y^{i-1}) + n\epsilon_n \\ &\leq \sum_{i=1}^n \mathbb{I}(M, Y^{i-1}; Y_i) + n\epsilon_n \\ &\stackrel{(b)}{\leq} \sum_{i=1}^n \mathbb{I}(M, S^{i-1}; Y_i) + n\epsilon_n \\ &\leq \sum_{i=1}^n \mathbb{I}(M, S^{i-1}, Z^{i-1}; Y_i) + n\epsilon_n \\ &\stackrel{(c)}{\leq} \sum_{i=1}^n \mathbb{I}(X_i; Y_i) + n\epsilon_n \\ &= n \sum_{i=1}^n \frac{1}{n} \mathbb{I}(X_i; Y_i) + n\epsilon_n \\ &= n \sum_{i=1}^n \mathbb{P}(T=i) \mathbb{I}(X_i; Y_i | T=i) + n\epsilon_n \\ &= n \mathbb{I}(X_T; Y_T | T) + n\epsilon_n \\ &\leq n \mathbb{I}(X_T, T; Y_T) + n\epsilon_n \\ &\stackrel{(d)}{=} n \mathbb{I}(X; Y) + n\epsilon_n \\ &\stackrel{(e)}{\leq} n \mathbb{I}(X; Y) + n\epsilon, \end{aligned} \quad (246) \quad (247)$$

where

- (a) follows from Fano's inequality;
- (b) follows from the Markov chain $(M, Y^{i-1}) - (M, S^{i-1}) - Y_i$;

(c) follows since S_i is independent of $(M, S^{i-1}, Z^{i-1}, X_i(M, S^{i-1}))$ and therefore

$$\mathbb{I}(M, S^{i-1}, Z^{i-1}; Y_i | X_i) \leq \mathbb{I}(M, S^{i-1}, Z^{i-1}; Y_i | X_i, S_i) = 0, \quad (248)$$

that is $(M, S^{i-1}, Z^{i-1}) - X_i - Y_i$ forms a Markov chain, which implies $V_i - X_i - Y_i$, where $V_i \triangleq (M, Z^{i-1})$, forms a Markov chain;

(d) follows by defining $X = (X_T, T)$ and $Y = Y_T$.

(e) follows by defining $\epsilon \triangleq \max\{\epsilon_n, \nu \geq \frac{\delta}{n}\}$.

Next, we lower bound nR as follows,

$$\begin{aligned} nR &\geq \mathbb{H}(M) \\ &\geq \mathbb{I}(M; Z^n) \\ &= \sum_{i=1}^n \mathbb{I}(M; Z_i | Z^{i-1}) \\ &\stackrel{(a)}{\geq} \sum_{i=1}^n \mathbb{I}(M, Z^{i-1}; Z_i) - \delta \\ &\stackrel{(b)}{=} \sum_{i=1}^n [\mathbb{I}(V_i; Z_i)] - \delta \\ &= n\mathbb{I}(V_T; Z_T | T) - \delta \\ &\stackrel{(c)}{\geq} n\mathbb{I}(V_T, T; Z_T) - 2\delta \\ &\stackrel{(d)}{=} n\mathbb{I}(V; Z) - 2\delta \end{aligned} \quad (249)$$

where

(a) follows from Lemma 3;

(b) follows by defining $V_i \triangleq (M, Z^{i-1})$;

(c) follows from Lemma 3;

(d) follows by defining $V = (V_T, T)$ and $Z = Z_T$.

For any $\nu > 0$, choosing n large enough ensures that

$$\begin{aligned} R &\geq \mathbb{I}(V; Z) - 2\nu, \\ &\geq \mathbb{I}(V; Z) - 2\epsilon, \end{aligned} \quad (250)$$

where the last inequality follows from definition $\epsilon \triangleq \max\{\epsilon_n, \nu\}$. To show that $\mathbb{D}(P_Z || Q_0) \leq \epsilon$, note that for n large enough

$$\mathbb{D}(P_Z || Q_0) = \mathbb{D}(P_{Z_T} || Q_0) = \mathbb{D}\left(\frac{1}{n} \sum_{i=1}^n P_{Z_i} \middle| \middle| Q_0\right) \leq \frac{1}{n} \sum_{i=1}^n \mathbb{D}(P_{Z_i} || Q_0) \leq \frac{1}{n} \mathbb{D}(P_{Z^n} || Q_0^{\otimes n}) \leq \frac{\delta}{n} \leq \nu \leq \epsilon. \quad (251)$$

Combining (247) and (250), and (251) shows that $\forall \epsilon_n, \nu > 0$, $R \leq \max\{x : x \in \mathcal{S}_\epsilon\}$. Therefore,

$$R \leq \max \left\{ x : x \in \bigcap_{\epsilon > 0} \mathcal{S}_\epsilon \right\}. \quad (252)$$

1) *Continuity at Zero:* One can prove the continuity at zero of \mathcal{S}_ϵ by substituting $\min\{\mathbb{I}(U; Y) - \mathbb{I}(U; S), \mathbb{I}(U, V; Y) - \mathbb{I}(U; S|V)\}$ with $\mathbb{I}(X; Y)$ and $\mathbb{I}(V; Z) - \mathbb{I}(V; S)$ with $\mathbb{I}(V; Z)$ in Appendix I and following the exact same arguments.

REFERENCES

- [1] A. B. Bash, D. Goeckel, and D. Towsley, "Limits of reliable communication with low probability of detection on AWGN channels," *IEEE J. Sel. Areas Commun.*, vol. 31, no. 9, pp. 1921–1930, Sep. 2013.
- [2] P. H. Che, M. Bakshi, and S. Jaggi, "Reliable deniable communication: Hiding messages in noise," in *Proc. IEEE Int. Symp. on Info. Theory (ISIT)*, Istanbul, Turkey, Jul. 2013, pp. 2945–2949.
- [3] L. Wang, G. W. Wornell, and L. Zheng, "Fundamental limits of communication with low probability of detection," *IEEE Trans. Inf. Theory*, vol. 62, no. 6, pp. 3493–3503, Jun. 2016.
- [4] M. R. Bloch, "Covert communication over noisy channels: A resolvability perspective," *IEEE Trans. Inf. Theory*, vol. 62, no. 5, pp. 2334–2354, May 2016.
- [5] M. Tahmasbi and M. R. Bloch, "First- and second-order asymptotics in covert communication," *IEEE Trans. Inf. Theory*, vol. 65, no. 4, pp. 2190–2212, Apr. 2019.
- [6] S.-H. Lee, L. Wang, A. Khisti, and G. W. Wornell, "Covert communication with channel-state information at the transmitter," *IEEE Trans. Inf. Forensics Security*, vol. 13, no. 9, pp. 2310–2319, Sep. 2018.
- [7] S. Salehkalaibar, M. H. Yassaee, and V. Y. F. Tan, "Covert communication over a compound channel," available at <https://arxiv.org/abs/1906.06675>, Jun. 2019.
- [8] P.-H. Lin, C. R. Janda, and E. A. Jorswieck, "Stealthy secret key generation," in *Proc. IEEE Global Conf. on Signal and Info. Processing (GlobalSIP)*, Montreal, QC, Canada, Mar. 2017, pp. 492–496.
- [9] P.-H. Lin, C. R. Janda, E. A. Jorswieck, and R. F. Schaefer, "Stealthy keyless secret key generation from degraded sources," in *51st Asilomar Conference on Signals, Systems, and Computers*, Pacific Grove, CA, USA, Apr. 2018, pp. 14–18.
- [10] M. Tahmasbi and M. R. Bloch, "Covert secret key generation," in *Proc. IEEE Conf. on Commun. and Network Security (CNS)*, Las Vegas, NV, USA, Dec. 2017, pp. 540–544.
- [11] —, "Framework for covert and secret key expansion over classical-quantum channels," *Phys. Rev. A*, vol. 99, p. 052329, May 2019.
- [12] Y. Chen and A. J. Han Vinck, "Wiretap channel with side information," *IEEE Trans. Inf. Theory*, vol. 54, no. 1, pp. 395–402, Jan. 2008.
- [13] A. Khisti, S. N. Diggavi, and G. W. Wornell, "Secret key agreement using asymmetry in channel state knowledge," in *Proc. IEEE Int. Symp. on Info. Theory (ISIT)*, Seoul, South Korea, Jul. 2009, pp. 2286–2290.
- [14] Y.-K. Chia and A. El Gamal, "Wiretap channel with causal state information," *IEEE Trans. Inf. Theory*, vol. 58, no. 5, pp. 2838–2849, May 2012.
- [15] H. Fujita, "On the secrecy capacity of wiretap channels with side information at the transmitter," *IEEE Trans. Inf. Forensics Security*, vol. 11, no. 11, pp. 2441–2452, Nov. 2016.
- [16] A. Sonee and G. A. Hodtani, "Wiretap channel with strictly causal side information at encoder," in *Proc. Iran Workshop on Commun. and Info. Theory (IWCIT)*, Tehran, Iran, May 2014, pp. 1–6.
- [17] T. S. Han and M. Sasaki, "Wiretap channels with causal state information: Strong secrecy," *IEEE Trans. Inf. Theory*, vol. 65, no. 10, pp. 6750–6765, Oct. 2019.
- [18] Z. Goldfeld, P. Cuff, and H. H. Permuter, "Wiretap channels with causal state information: Strong secrecy," *IEEE Trans. Inf. Theory*, vol. 66, no. 3, pp. 1497–1519, Mar. 2020.
- [19] H. ZivariFard, M. R. Bloch, and A. Nosratinia, "Keyless covert communication in the presence of non-causal channel state information," in *Proc. IEEE Info. Theory Workshop (ITW)*, Visby, Sweden, Aug. 2019, pp. 1–5.
- [20] —, "Keyless covert communication in the presence of channel state information," in *IEEE Int. Symp. on Info. Theory (ISIT)*, Los Angeles, CA, USA, Jun. 2020, pp. 834–839.
- [21] —, "Keyless covert communication via channel state information," available at <https://arxiv.org/abs/2003.03308>, Mar. 2020.
- [22] E. L. Lehmann and J. P. Romano, *Testing Statistical Hypotheses*. New York, NY, USA: Springer-Verlag, 2005.
- [23] I. Sason and S. Verdú, " f -divergence inequalities," *IEEE Trans. Inf. Theory*, vol. 62, no. 11, pp. 5973–6006, Nov. 2016.
- [24] S. I. Gel'fand and M. S. Pinsker, "Coding for channel with random parameters," *Problem Control Inf. Theory*, vol. 9, no. 1, pp. 19–31, Jan. 1980.
- [25] A. D. Wyner and J. Ziv, "The rate-distortion function for source coding with side information at the decoder," *IEEE Trans. Inf. Theory*, vol. 22, no. 1, pp. 1–10, Jan. 1976.
- [26] P. Cuff, "Distributed channel synthesis," *IEEE Trans. Inf. Theory*, vol. 59, no. 11, pp. 7071–7096, Nov. 2013.
- [27] M. H. Yassaee, M. R. Aref, and A. A. Gohari, "A technique for deriving one-shot achievability results in network information theory," in *Proc. IEEE Int. Symp. on Info. Theory (ISIT)*, Istanbul, Turkey, Jul. 2013, pp. 1287–1291.

- [28] S. Watanabe, S. Kuzuoka, and V. Y. F. Tan, “Nonasymptotic and second-order achievability bounds for coding with side-information,” *IEEE Trans. Inf. Theory*, vol. 61, no. 4, pp. 1574–1605, Apr. 2015.
- [29] A. Lapidath and Y. Steinberg, “The multiple access channel with causal and strictly causal side information at the encoders,” in *Int. Zurich Semin. Commun.*, Zurich, Switzerland, Mar. 2010, pp. 13–16.
- [30] H. G. Eggleston, *Convexity*, 6th ed. Cambridge, U.K: Cambridge University Press, 1958.
- [31] A. El Gamal and Y.-H. Kim, *Network Information Theory*, 1st ed. Cambridge, U.K: Cambridge University Press, 2012.
- [32] C. E. Shannon, “Channels with side information at the transmitter,” *IBM J. Res. Develop.*, vol. 2, no. 4, pp. 289–293, Oct. 1958.
- [33] M. H. Yassaee and M. R. Aref, “Multiple access wiretap channels with strong secrecy,” in *Proc. IEEE Info. Theory Workshop (ITW)*, Dublin, Ireland, Sep. 2010, pp. 1–5.
- [34] E. C. Song, P. Cuff, and H. V. Poor, “A rate-distortion based secrecy system with side information at the decoders,” in *Proc. 52th Annual Allerton Conference on Communication, Control, and Computing*, Monticello, IL, Sep. 2014, pp. 755–762.
- [35] I. Csiszár and J. Körner, “Broadcast channels with confidential messages,” *IEEE Trans. Inf. Theory*, vol. 24, no. 3, pp. 339–348, May 1978.
- [36] J. Hou and G. Kramer, “Informational divergence approximations to product distributions,” in *Proc. 13th Can. Workshop Inf. Theory (CWIT)*, Toronto, ON, Canada, Jun. 2013, pp. 76–81.
- [37] Z. Goldfeld, G. Kramer, H. H. Permuter, and P. Cuff, “Strong secrecy for cooperative broadcast channels,” *IEEE Trans. Inf. Theory*, vol. 63, no. 19, pp. 469–495, Jan. 2017.