

NFV Platform Design: A Survey

Tianzhu Zhang

Email: tianzhu.zhang1989@gmail.com

Laboratory of Information, Networking and Communication Sciences (LINCS)

Abstract

Due to the intrinsically inefficient service provisioning in traditional networks, Network Function Virtualization (NFV) keeps gaining attention from both industry and academia. By replacing the purpose-built, expensive, proprietary network equipment with software network functions consolidated on commodity hardware, NFV envisions a shift towards a more agile and open service provisioning paradigm with much lower capital expenditure (CapEx) and operational expenditure (OpEx). Nonetheless, just like any complex system, NFV platforms commonly consist of abounding software and hardware components and usually incorporate disparate design choices based on distinct motivations or use cases. This broad collection of convoluted alternatives makes it extremely arduous for network operators to make proper choices. Although numerous efforts have been devoted to investigating different aspects of NFV, none of them specifically focused on NFV platforms or attempted to explore the design space. In this paper, we present a comprehensive survey on NFV platform design. Our study solely targets existing NFV platform implementations. We begin with an architectural view of the standard reference NFV platform and present our taxonomy of existing NFV platforms based on the principal purpose of design. Then we thoroughly explore the design space and elaborate on the implementation choices each platform opts for. We believe that our study gives a detailed guideline for network operators or service providers to choose or implement the most appropriate NFV platforms based on their respective requirements. Note that this report serves as a complementary document for a published IEEE TNSM paper [1]. We will periodically update this document to include the newly proposed NFV platforms and design choices.

1 Introduction

Traditionally, network services are provisioned using purpose-built, proprietary hardware appliances (or middleboxes). Middleboxes embody a large variety of specialized functions to forward, classify, or transform traffic based on packet content. Examples of middleboxes include but are not limited to L2 Switching, Routing, Network Address Translation (NAT), Firewall (FW), Deep Packet Inspection (DPI), Intrusion Detection System (IDS), Load Balancer (LB), WAN optimizer, and stateful proxy. Nowadays, middleboxes are ubiquitous in enterprise networks [2]. However, with the increasingly diversified user requirements as well as the rapid growth of Internet traffic, in terms of both volume and heterogeneity [3], hardware middleboxes begin to exhibit several fundamental disadvantages. First off, middleboxes are generally expensive to acquire and usually require domain-specific knowledge to manage them, resulting in large capital expenditure (CapEx) and operational expenditure (OpEx). Also, adding customized functionalities is extremely time-consuming if not impossible, and it sometimes takes an entire purchase cycle (e.g, four years) to bring in equipment with new features [4]. Such tight coupling with the hardware production cycle considerably hampers network innovation and prolongs time-to-market. Deploying new network services (NSs) is also a tedious process, as technicians are required to visit specific sites and place the middleboxes in a pre-defined order to form the correct service function chains (SFCs). Service instantiation might even take days. Worse still, service maintenance usually involves constant repetition of the same process. Furthermore, because of the inherent inflexibility, it is not trivial for hardware middleboxes to elastically scale in and out based on the shifting demand or other system dynamics. Consequently, network operators usually resort to peak-load provisioning, which in turn leads to ineffective resource utilization and extravagant energy consumption.

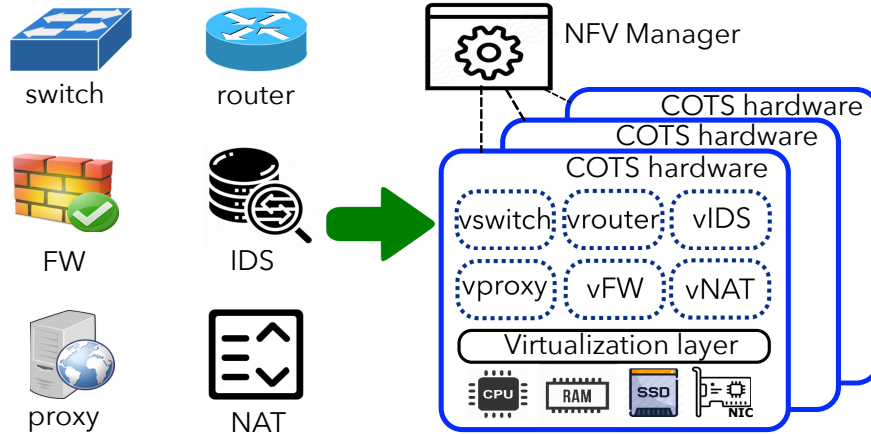

Figure 1: Traditional vs. NFV paradigm

To improve service provisioning and get rid of network ossification, telecommunication operators began to pursue new solutions that can guarantee both cost-effectiveness and flexibility. The advent of Software Defined Networking (SDN) [5] and Network Function Virtualization (NFV) [6] provides alternative approaches for network management and service provisioning. SDN decouples the control plane from the data plane and leverages a logically centralized controller to configure the programmable switches based on a global view, while NFV replaces specialized middleboxes with software Virtual Network Functions (VNFs) consolidated on Commodity Off-The-Shelf (COTS) hardware. The key to their success lies in separating the evolution timeline of software network functions and specialized hardware, completely unleashing the potential of the former. An illustrative example contrasting the NFV paradigm with the traditional network is shown in Fig. 1. Compared to the traditional service provisioning paradigm based on hardware middleboxes, NFV manages to achieve cost-effectiveness by consolidating multiple instances of VNFs on high-volume yet inexpensive servers, routers, or storage. Service provisioning in NFV is also highly simplified as the previously troublesome tasks, such as middlebox deployment, monitoring, migration, and scaling can be optimally automated through software control mechanisms. It is thus convenient for NFV solutions to exploit available resources and management tools of the cloud infrastructure or network edge. Also, NFV remarkably promotes network innovation and accelerates the time-to-market process as network function development is cut down to writing software programs using standard application programming interfaces (APIs).

Thanks to these indispensable merits, NFV keeps gaining momentum from both industry and academia. The first concerted effort towards NFV standardization began in 2012, with the appointment of the European Telecommunications Standards Institute (ETSI) [7] as Industry Specification Group. Currently, ETSI consists of more than 500 members across the world, including major telecommunication operators, service providers, manufacturers, as well as universities. In the meanwhile, the continuous advancement of COTS hardware capabilities and the emergence of high-speed packet processing techniques adequately close the previously huge performance gap between software network functions and specialized middleboxes. Resources of other hardware components, such as Graphics Processing Unit (GPU), smartNICs, and in-path programmable network devices, can also be exploited to share the workload and alleviate the burden of CPU. These technical impetuses immeasurably stimulate the growth of NFV.

During the last six years, a large assemblage of NFV platforms has been implemented to spur the innovation and evolution of NFV. However, just like any complex system, NFV platforms usually encompass profuse software and hardware components and embrace divergent design choices driven by their respective motivations or use cases. The design space of these platforms can be very expansive, with design choices ranging from high-level VNF development, such as VNF execution models, state management schemes, or genres of APIs, to low-level infrastructure details, like packet I/O frameworks, VNF interconnection methods, or virtualization techniques. They also opt for various acceleration techniques including compute batching, zero-copy packet transfer, parallelization, data prefetching, and computation offloading. Such a broad range of platform implementations coupled with even more extensive design space makes it extremely difficult (if not impossible) for network operators to choose the most suitable solutions. The tradeoffs and caveats

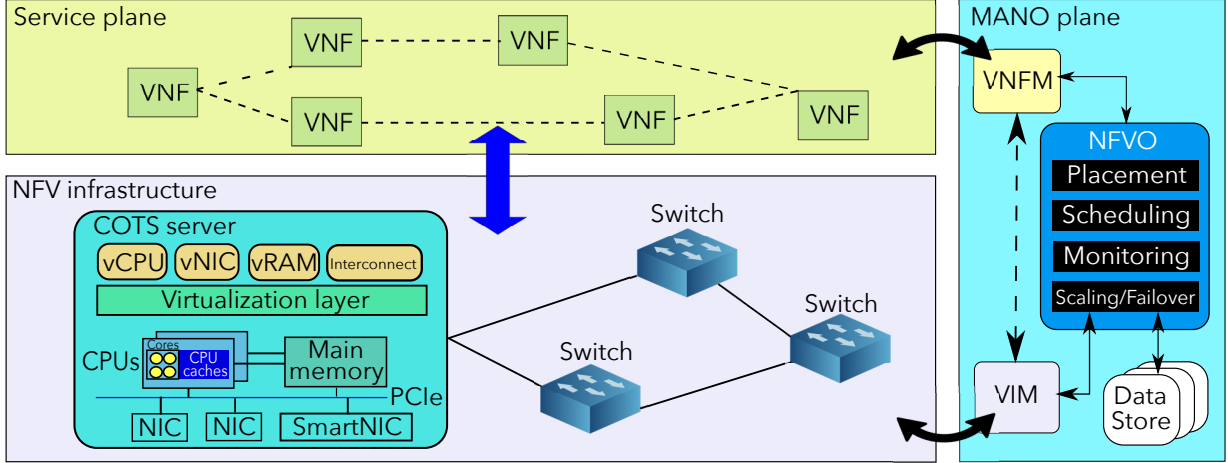

Figure 2: The architecture of a general NFV platform

between different design choices are also unclear.

Several existing works have investigated some aspects of NFV, including VNF placement [8], resource allocation [9], service function chaining [10], and security [11], but none of them specifically focused on the design of NFV platforms, nor did they attempt to explore the design space or review different implementation choices. In [12–14], the authors investigated a subset of industrial NFV projects, which are complementary to our work.

In this paper, we focus on existing NFV platforms and present a comprehensive survey on their design. The contribution of this paper can be summarized as follows:

- we classify existing NFV platforms based on main purposes and review their internals.
- we explore the NFV design space and discuss the various design choices adopted by existing platforms.

This paper is organized as follows: in Sec. 2, we give an architectural overview of the components of NFV platforms. Then we present our taxonomy on existing platforms in Sec. 3. In Sec. 4, we propose a collection of critical design choices and survey the solutions adopted by different platforms. We draw conclusion in Sec. 5.

2 NFV platform: an architectural overview

We devote this section to presenting a general architectural overview of a typical NFV platform and reviewing the key components in depth. Although a reference architecture has been defined by the ETSI specification [15], most of the existing NFV platforms did not strictly follow it. As a result, we seek to combine the ETSI reference architecture with those of the existing platforms and present a generic view, as illustrated in Fig. 2. An NFV platform generally consists of three primary components, namely the NFV Management and Orchestration (MANO) plane, the service plane, and the NFV Infrastructure (NFVI). The MANO plane provides centralized control over service provisioning and management. The NFVI contains a collection of computation, storage, and network resources that are distributed across different infrastructural nodes. MANO plane components systematically monitor and schedule the resources to build a virtualized environment and accommodate different network services. The service plane contains a diversified collection of VNFs that are ordered in the form of service chains to fulfill the promised network services. These service chains are also carefully monitored and adjusted by the MANO plane components to efficiently multiplex the NFVI resources. In general, the service plane is enabled through concerted operations from both the MANO plane and NFVI.

2.1 MANO plane

NFV Management and Orchestration (MANO) is the central point for service provisioning in NFV. A MANO system typically consists of three sub-systems: NFV Orchestrator (NFVO), Virtual Infrastructure Manager (VIM), and VNF Manager (VNFM). As shown in Fig. 2, NFVO is responsible for the instantiation, management, and termination of network services. At present, an NFVO commonly encompasses different modules to apply different MANO operations. On the right part of Fig 2, we illustrate four example modules. The placement module is in charge of rendering the best deployment, possibly in an incremental fashion. When new services need to be deployed, the placement module analyzes the service descriptions or requirements specified by network operators, constructs an aggregated service representation (e.g. service processing graph), performs necessary optimizations (e.g. function merging, redundant elimination), and calculates the best possible placement strategy by determining the PoPs to deploy the related VNFs and their chaining order. The monitoring module is responsible for collecting statistics and events from both the service plane and the infrastructure and provides runtime feedback to other NFVO modules. Based on the traffic condition collected on-the-fly, the placement module can recalculate a new placement to achieve better performance. The scheduling module can dynamically make fine-grained scheduling decisions to attain resource efficiency. The scaling/failover module can also collaborate with the placement module to scale in/out particular VNFs or service chains to cater to traffic fluctuation or instantiate new VNF replicas upon failure. Based on the decisions made by the aforementioned modules, the NFVO closely interacts with the other two MANO plane components to realize the intended service configurations and resource allocations.

VIM is designed to configure infrastructure components to accommodate the heterogeneous VNFs or service chains instantiated in the service plane. In specific, it directs the provision/release/upgrade of NFVI resources and manages the mapping between virtual and physical resources. It also manages the data path for network services by creating/deleting/updating virtual interfaces and logical links and collects the NFVI software and hardware status on behalf of the NFVO monitoring module. Note that an instance of VIM might control all the resources of the whole NFVI or that of multiple NFVI-PoPs. In some cases, a VIM might also just control a specific type of resource.

On the other hand, VNFM interacts with the service plane and takes care of the instantiation, scaling, upgrade, and termination of individual VNFs and service chains. It also needs to synchronize with VIM to allocate or release the related infrastructural resources. According to ETSI specification, the MANO system might also maintain several data stores to hold configuration information such as network service descriptions, VNF templates, NFVI resources, etc.

2.2 NFV Infrastructure

NFV Infrastructure (NFVI) contains all the essential hardware and software components to compose virtual network services. The infrastructure might belong to Internet service providers, cloud/edge operators, or simply infrastructure providers. It usually embodies a large variety of computing nodes and network equipment. Each computing node or network equipment is commonly referred to as NFVI-PoP. Network equipment in NFVI can be traditional purpose-built switches/routers or the emerging programmable switches that can be remotely orchestrated with SDN or P4 [16] semantics. The most typical form of computing node in NFVI is the COTS servers. These servers normally contain several critical hardware components, including the physical Network Interface Controllers (NICs), multicore CPUs, and main memory, and they are interconnected through PCI buses. The physical NICs are capable of operating at the Gigabyte level with multiple queues promoting parallelization. High-speed packet I/O techniques are also integrated by the NICs to transport packets to the service plane. Inside the server, multicore CPUs are distributed across non-uniform memory access (NUMA) nodes to speed up traffic processing. Aside from CPU, other computing units such as smartNIC and GPU are also widely utilized by existing NFV platforms to further boost performance. The virtualization layer in the COTS server provides the environment to accommodate network functions. The virtualization can be at the hardware level relying on bare-metal hypervisors or at the OS level using container engines. Some platforms even execute network functions as ordinary processes, which is addressed as Physical Network Functions (PNFs) in some works. In this paper, we universally refer to them as VNFs for the sake of simplicity. To ensure efficient communication between the VNFs and the external network, virtual interconnects need to be precisely established. This is typically accomplished using state-of-the-art

software virtual switches or customized forwarding tables. Note that we consider physical links between COTS servers and network equipment as part of NFVI as well.

2.3 Service plane

The service plane is populated with a variety of Virtual Network Functions (VNFs) implementing different processing to constitute various network services. The distribution of VNFs inside virtual environments is quite flexible. For instance, a VNF or a whole service chain can be mapped to a single VM for execution, a VNF can also be split into finer-grained processing elements and deployed across multiple NFV PoPs. Also, VNFs are usually constructed using different programming abstractions and operate in different runtime execution models.

3 Taxonomy of NFV platforms

We devote this section to reviewing existing NFV platforms and classifying them according to their primary design purpose. Based on our literature review and the reference architecture, we classify existing NFV platforms based on three general design purposes, namely integrated NFV platform, MANO system, and NFVI optimization. An integrated NFV platform contains both MANO plane and NFVI to support either end-to-end service provisioning or VNF development. A MANO system deals with all or a subset of the management issues such as instantiation/termination, placement, dynamic scaling, monitoring, and resilience of network services. An NFVI optimization platform strives for guaranteeing an efficient infrastructural packet data path by optimizing the related procedures and eliminating redundant processing.

3.1 Integrated NFV platform

Integrated NFV platforms can be further classified into two categories. The first category is for network operators or service providers to efficiently provision end-to-end services for their clients or subscribers. The second category is for network developers to make VNF implementation less time-consuming and error-prone.

End-to-end service provisioning

Several platforms were proposed for functionality implementation. **UNIFY** [17] and **Cloud4NFV** [18] are two earliest projects for integrated NFV platforms. UNIFY introduces a general framework to automate service provisioning. It employs a layered graph abstraction to automatically map user-specified services into actual SFCs deployed to the underlying NFVI PoPs. Cloud4NFV provides an SFC model to allow for fine-grained traffic classification and steering and relies on cloud management tools to perform NFV MANO operations. **CloudBand** [19] is an integrated NFV platform composed of Cloudband node and a management system. The CloudBand node supplies resources to accommodate network services. The management system performs MANO operations across different service domains. **GNF** [20] brings NFV to the network edge. It exposes a graphical user interface to specify service intent and display system events and uses a manager to perform MANO operations. An agent is embedded into each edge device to manage the containerized VNFs. Considering the resource constraint of edge devices, it runs VNFs in lightweight Linux containers instead of VMs. **DeepNFV** [21] is built on top of GNF. It incorporates deep learning techniques inside VNFs to learn and discover hidden data patterns and provide enhanced services such as traffic classification, QoS optimization, link status analysis, and so on. **NetFATE** [22] employs a similar architecture and deploys VNFs on both data center servers and edge devices, with considerations of runtime traffic load and Quality-of-Experience (QoE). **SONATA** [23] brings DevOps concept into NFV by providing a service development toolchain integrated with a service platform and orchestration system. The toolchain comprises a service programming abstract with support tools to allow developers to implement, monitor, and optimize VNFs or SFCs. The service platform encompasses a customizable MANO framework to deploy and manage network services. It also supports platform recursion and network slicing. **Eden** [24] is another platform purposed for provisioning network functions at end-hosts in a single administrative domain. It is composed of a controller, stages, and enclaves at the end-hosts. The controller provides centralized VNF coordination based on its global network view. Stages reside in the end-host stack to associate application

semantics to particular traffic classes. The per-host Eden enclave maintains a set of Match/Action tables to decide the destination VNF for each packet based on its traffic class. VNFs in Eden are written in F# language and are compiled into executable byte-code, which is subsequently interpreted inside the enclaves.

Other integrated NFV platforms concentrate on performance with high traffic load (e.g. 40/100 Gbps). **OpenBox** [25] allows developers to implement VNF logic through the northbound API of the OpenBox controller, which in turn deploys the logic to the data plane and realizes the intended processing sequence through the OpenBox protocol. The OpenBox controller additionally merges the core control logic of multiple VNFs to avoid duplicated processing and spare NFVI-PoP resources for other tasks. The OpenBox data plane is extensible with specialized hardware or pure software. By default, OpenBox contains over 40 processing blocks that can be chained to realize various VNFs, and it can further seamlessly integrate custom blocks at runtime. **Slick** [26] allows developers to write network functions in high-level programming language and specify intended network service for different traffic flows or classes. The Slick controller performs the placement and traffic steering using several heuristic algorithms. In particular, the Slick runtime parses the specified policy and decides the optimal servers to place the elements, and installs forwarding routes to the in-path switches to realize the intended processing sequence. A shim is configured on each server to provide up-to-date system status for Slick runtime to make incremental optimizations. **Elastic Edge (E2)** [27] is meant for a general NFV platform that frees developers from common deployment and management issues, which are instead delegated to the E2 manager. E2 allows network operators to express network policies in terms of individual pipelets, each of which consists of a subset of input traffic (or traffic class) and a processing graph. Similar to OpenBox, the E2 manager merges the pipelets into a single graph and instructs local agents to place the corresponding network functions across the server cluster and interconnect them through the high-speed E2 data plane. E2 also provides hooks for the VNFs and the data plane to detect system overload, and dynamically scales NF instances with flow affinity guaranteed. **SDNFV** [28] combines SDN and NFV to realize a flexible, hierarchical control framework over VNFs. It comprises three hierarchies: SDNFV application, SDN controller, NFV orchestrator, and NF manager. SDNFV application utilizes a graph abstraction to represent the intended network services for different traffic flows. Then it proposes a heuristic algorithm to jointly deploy the VNFs to COTS servers and configure traffic routes across them, through the SDN controller and NFV orchestrator. An instance of NF manager is installed on each COTS server to manage the local VNFs and traffic routing. Each manager maintains an extended OpenFlow (OF) table based on host-level status. This table can also be configured by the remote SDN controller (for default routing) and the local VNFs (based on their internal states), realizing a more flexible control paradigm beyond SDN. **MicroNF** [29] deals with the consolidation, placement, scaling, and scheduling for modularized SFCs altogether. It consists of a centralized controller and a high-speed infrastructure. The MicroNF controller exploits a graph constructor to analyze inter-element dependency and reconstruct the service graph to reuse the redundant elements. Then it uses a placer to optimally place and consolidate modularized VNFs to reduce inter-VM data transfer. At runtime, it dynamically collects element statistics and applies two resource scaling algorithms for SFC scaling with minimal inter-element latency. Also, the MicroNF infrastructure ensures high-speed, consistent packet forwarding, and fair VNF scheduling. μ **NF** [30] advocates designing network functions as Microservices since the self-contained, loosely-coupled design supports fine-grained resource allocation and VNF scaling. μ NF is designed for building VNFs and SFCs using disaggregated, reusable network processing components. It consists of a centralized orchestrator and a cluster of per-server agents. Similar to other integrated NFV platforms, it allows network operators to specify service requests as directed graphs, which are converted to equivalent forwarding graphs by the orchestrator. Then agents on the related COTS servers are instructed to deploy and interconnect the corresponding VNFs according to the graph specifications. **Metron** [31] utilizes the available resources of both underlying hardware and programmable network to accomplish high-speed processing. The Metron controller parses the traffic classes associated with a service chain and generates a synthesized processing graph. Then it decomposes the graph into a bunch of stateless operations offloaded to the in-path programmable network equipment while mapping the remaining stateful operations to COTS servers. To reduce the overhead of software-based traffic dispatching, Metron leverages the in-path programmable switches to tag packets, which are matched by the COTS NIC to dispatch packets to the correct cores for “run-to-completion” processing. For management, Metron additionally deploys an agent on each server to monitor the runtime statistics and scale overloaded VNF instances accordingly. **OPNFV** [32] is a joint open-source project to promote NFV deployment and innovation. It involves a large compilation of tasks including continuous integration of components from

upstream projects, function verification, performance benchmarking, and service automation. As an integrated platform, it provides full-fledged features including VNF management, dynamic service provisioning, prompt fault detection and recovery, and vendor-/operator-agnostic deployment. **NNF** [33] explores capabilities of resource-constrained devices to deploy VNFs. The authors post some preliminary results to prove the feasibility of implementing NNF over a variety of servers with heterogeneous hardware specifications and accelerators. **CoNFV** [34] combines cloud and end-hosts to reduce service deployment cost and processing latency. An abstraction is proposed to divide SFC processing logics between cloud infrastructure and end-hosts. An intuitive API is also designed for developers to port existing VNFs into CoNFV.

VNF development

There is a collection of works dedicated to facilitating the development of VNFs. They aim at supplying high-level APIs to facilitate the VNF development process. Most of them are equipped with runtimes to guarantee efficient VNF execution. The spirit of these works is to free developers from reinventing the wheels for common management tasks and let them focus on VNF control logic implementation. **xOMB** [35] is the earliest endeavor for building scalable, programmable, and performant middleboxes on COTS servers. It arranges a set of programmable modules into a general pipeline to implement the expected network function. The xOMB control plane monitors the execution pipeline to make timely adjustments upon instance failure. **CoMb** [36] advocates the consolidation of network functions at both execution and management level. The centralized CoMb controller takes as input the service policies and infrastructure specifications and solves an optimization model to decide the optimal deployment strategy, which is mapped to the distributed CoMb middleboxes by allocating the required resources. **FlowOS** [37] is a kernel-based programmable platform purposed for middlebox development. It implements an API to facilitate flow processing VNF and conceal low-level complexities such as Inter-process communication, low-level packet delivery, and synchronization. **NetBricks** [38] facilitates the VNF development process by implementing a small set of core processing elements that are highly optimized and customizable through user-defined functions. Instead of relying on VMs or containers, NetBricks employs safe language, an efficient runtime library, and unique types to ensure a similar level of VNF isolation with much lower overhead. **Scylla** [39] is a declarative language for flow-level VNF development. It provides several high-level abstractions to allow developers to express their intents such as SFCs, VNF monitoring, and state management. The Scylla runtime is in charge of fulfilling these intents to the infrastructure. **libVNF** [40] implements a generic library to assist the development of VNFs ranging from L2/L3 middleboxes to transport-/application-layer endpoints, with the support of seamless integration of the kernel and third-party network stacks. A request object abstraction is proposed to maintain application states across multiple non-blocking, event-driven callbacks. The libVNF API is also capable of interacting with multi-level data stores for state management across threads of a single VNF or multiple VNF replicas. **Flick** [41] brings application-specific semantics into VNF development on multi-core COTS servers. The authors implement a domain-specific language named *flick* that offers high-level abstractions and common primitives to assist VNF development. The compiler automatically translates the flick programs into parallel task graphs with bounded runtime resource usage. Multiple graphs can execute simultaneously without interference through cooperative scheduling. **NFMorph** [42] proposes to decouple network function logic from packet processing optimization. VNF programs are expressed in a domain-specific language with primitives that are coherent with packet processing pipelines. NFMorph runtime constructs the near-optimal processing pipeline incrementally from a preliminary pipeline based on code profiling, traffic sampling, and system constraints. **Polycube** [43] is purposed to build VNFs that can be dynamically adjusted at runtime. Its kernel fast path leverages extended Berkeley Packet Filter (eBPF) [44] to sustain high-speed packet processing. It also exposes a set of abstractions to ease SFC development. The following platforms adopt different means to avoid the complexities introduced by the callback-based asynchronous programming model. **NetStar** [45] implements a flow-based asynchronous interface combined with the future/promise C++ library for VNF development. Instead of spreading control logic across multiple callback functions, NetStar mimics sequential execution by chaining multiple future objects and continuation functions over a single function call. **ClickNF** [46] augments the Click modular router [47] with a modular, configurable, and extensible TCP stack to build L2-L7 network functions. It further incorporates DPDK for kernel-bypassing packet I/O. A blocking I/O primitive is also proposed to alleviate development difficulty imposed by the traditional asynchronous non-blocking I/O paradigm. **S6** [48] extends distributed state

object (DSO) with a programming model to build elastically scalable VNFs. The S6 runtime manages the shared VNF states distributed in the DSO space. To meet performance requirements, S6 employs a set of optimizations including micro-threaded scheduling, DSO space reorganization. **StatelessNF** [49] embraces the separation of concerns design by decoupling the VNF states from processing so that developers only need to concentrate on VNF-specific logic, while StatelessNF arranges for state replication and management tasks. The VNF states are maintained in a distributed key-value data store that guarantees low-latency access and data resilience. The orchestration plane dynamically monitors VNF/infrastructure status and makes adjustments. **NFVector** [50] tackles efficient flow migration and failure recovery. It employs a distributed actor model for low processing abstraction and provides APIs to build VNFs with resilience guarantees. The per-flow actors can perform flow migration and replication in parallel while NFVector runtime timely schedules each actor and guarantees high-performance execution.

3.2 Management and orchestration

A lot of platforms are purposed to provide NFV MANO solutions. Some of them strive for full-fledged, holistic MANO systems, while others tackle only a facet of the MANO issues, such as the scheduling, monitoring, scaling, load-balancing, failover, and management of VNFs and SFCs. In this section, we discuss these two categories of solutions respectively.

Holistic MANO system

ETSO [51] is an ETSI-compliant NFV MANO platform for end-to-end SFC provisioning over heterogeneous cloud environments. It addresses key NFV orchestration challenges with a shared service abstraction, optimal VNF/SFC placement algorithms over heterogeneous technologies related to NFV, SDN, and cloud computing. **OpenMANO** [52] aims at implementing the ETSI NFV MANO framework with guaranteed levels of performance and portability. It consists of a MANO system (openmano), a virtual infrastructure manager (openvim), and a graphical user interface (GUI). The openvim directly manages with the NFVI resources. It also interacts with an SDN controller to create the intended traffic data path and relies on a REST northbound API to communicate with the openmano, where concerned MANO tasks are conducted. **Open Baton** [53] is another ETSI MANO-compliant platform with the major objective of developing an extensible and customizable framework for service orchestration across heterogeneous NFV Infrastructures. It manages a diverse set of VNFs running on a multi-site NFVI with heterogeneous virtualization technologies. It also features network slicing using SDN technologies to multiplex the infrastructural resources across multiple VNF instances or network services. **vConductor** [54] supports completely automated virtual network deployment by simplifying the provisioning procedure. It also adopts a multi-objective resource scheduling algorithm to meet individual business requirements and uses enhanced inventory management for fault isolation. It further employs a plug-in architecture with modular design to enhance the interoperability with various NFV management entities. **T-NOVA** [55] leverages SDN controllers and cloud management tools to design and implement a software NFV MANO stack to automate the deployment and management of Network Functions-as-a-Service (NFaaS) over virtualized network infrastructures. In [56], an open-source toolkit is implemented and evaluated using T-NOVA for end-to-end service provisioning in Datacenter-based NFVI. **TeNOR** [57] is an NFV orchestrator based on microservice architecture. It proposes two approaches to address resource and service mapping. **5TONIC** [58] is an open-source NFV MANO platform supporting secure cross-site message exchanges for control plane and data plane. It can provide experimental environments to multiple authorized parties with pre-defined security policies.

Scaling and failover

One attractive aspect of NFV is the flexibility to cope with traffic and system dynamics. When input traffic swells, the MANO plane can dynamically launch new instances to rebalance the workload. When a VNF instance crashes, new replicas can also be promptly initiated to avoid service disruption. Correspondingly several platforms endeavor to guarantee efficient scaling and failover, especially for stateful VNFs. **Split/Merge** [59] exposes a programming abstraction that promises transparent, load-balanced VNF scaling with guaranteed per-flow state consistency. In its prototype system, a centralized orchestrator along with an SDN controller is employed to direct VNF scaling and flow migration. A VMM agent is deployed on

each server to create or remove VNFs on demand. By integrating the Split/Merge API, per-flow VNF states are Split or Merged across multiple replicas. The system then migrates the relevant states and configures the network to direct flows to the correct replicas. **TFM** [60] also aims at achieving safe, transparent, and efficient flow migration. Similar to Split/Merge, it instructs the migration process through a centralized controller. The controller decouples flow and state migration processes with three modules: a state manager, a flow manager, and a forwarding manager. The state manager conducts state migration through southbound APIs. The forwarding manager interacts with the SDN controller to traffic steering rules. The flow manager manages the TFM boxes, which perform packet classification and buffering during flow migration. **OpenNF** [61] is a non-intrusive control framework with guaranteed SLAs, correct packet processing, and efficient resource usage. It implements a controller that consists of an event-driven model to capture relevant packets, a southbound API to request the import/export of VNF states at different granularities (i.e. single/multiple/all flows), and a northbound API for control applications to instruct state migration or synchronization. In particular, state migration is carefully crafted to avoid packet losses or out-of-order processing, while state synchronization can be performed with either strong or eventual consistency. **DiST** [62] and **U-HAUL** [63] follow similar procedures for state and flow migration, but does not require the involvement of the centralized controller. For instance, U-HAUL aims at implementing an efficient state migration framework. Based on the observation that mice flows are usually short-lived and their state/flow migrations incur huge overhead, it thus only identifies and migrates the execution states for elephant flows while keeps states of mice flow in the original VNF instance until expiration. By reducing the number of migrated flow states, the migration process becomes more efficient. **LEGO** [64] is designed to scale VNFs empowered by Artificial Neural Network (ANN). It proposes a traffic splitting scheme to split incoming packets with an ideal granularity. It also partitions ANN-based VNFs into smaller blocks to smooth the VNF scaling process. The centralized LEGO controller keeps monitoring the resource utilization for the blocks to achieve resource efficiency by dynamically replicating or merging them. **Lange et al.** [65] proposes a machine learning approach to adapt the number of VNF replicas based on recent monitoring data. The authors also propose a workflow to generate labeled training data that can reflect the real-world network dynamics. **StateAlyzr** [66] is a non-intrusive framework that automatically handles state clone and migration based on program analysis. It employs program analysis techniques and three algorithms to automatically identify all relevant VNF states that need to be redistributed, reducing target codebase and porting effort. In specific, StateAlyzr undertakes a three-stage procedure: it begins by identifying per-/cross-flow state, based on which it filters the updatable ones and identifies the relevant header fields. **CHC** [67] adopts a set of state management and optimization techniques to ensure service correctness without degrading performance. In particular, it offloads VNF states to the distributed data store and employs state caching and update algorithms to ensure high performance. It additionally leverages metadata to guarantee them a set of correctness properties during traffic redistribution and instance/component failures. **SFC-Checker** [68] is a diagnosis framework to verify the correctness of SFC forwarding behaviors. It extends OpenFlow to represent each VNF with a Match/Action table and a state machine and builds a stateful forwarding graph to capture both forwarding behaviors and state transitions so that SFC forwarding behaviors can be verified under different traffic conditions. **FTMB** [69] adopts log and rollback recovery scheme to conduct VNF failover using log replay. It incorporates two approaches, ordered logging and parallel release, to retain correctness and high-performance rollback.

Scheduling

Some NFV platforms are specialized for VNF scheduling to achieve performance isolation or resource efficiency. **NFVnice** [70] is an NFV framework providing fair scheduling and efficient chaining. In particular, It adopts rate-cost proportional fairness by adjusting the CPU weight of each VNF based on its estimated traffic arriving rate and service time. The scheduling is performed by tuning the OS scheduler via Linux cgroups. In addition, it actively monitors VNF backlogs and employs a back-pressure mechanism to early-drop packets for each congested service chain to spare resources. It also composes an asynchronous scheme to multiplex I/O with processing. **EdgeMiner** [71] seeks to reuse the spared CPU resources of VNFs to execute data processing applications in the network edge. EdgeMiner chooses interrupt-based I/O for VNFs, instead of polling, to save CPU resources under the low workload. It also employs a back-pressure scheme to dynamically detect service chain overloads and puts upstream VNFs into sleep to harvest the otherwise

wasted CPU cycles. **UNiS** [72] is a scheduling system tailored for poll-mode DPDK-based VNFs. For each worker core, it subsequently retrieves statistics from the inter-VNF buffer of the assigned SFCs and makes scheduling decisions based on buffer occupancy. The scheduling is non-intrusive as UNiS just tunes parameters of the Linux Realtime Scheduling without rewriting the VNFs. **SNF**¹ [74] leverages serverless computing for stateful VNFs. It dynamically traces the workload demands for each VNF and allocates compute resources at a fine granularity. A peer-to-peer in-memory store is deployed to proactively replicate the states and reduce packet processing latency. **ResQ** [75] is a cluster-based resource management framework with guaranteed service layer objectives. It consists of a performance profiler and a scheduler. The profiler performs a set of experiments on the target VNFs to construct profiles. Based on the profiling results, the ResQ scheduler computes a resource-efficient allocation using a greedy approach. ResQ also periodically solves a Mix Integer Linear Programming (MILP) formulation to obtain the optimal allocation, which can be applied to substitute the current allocation if a pre-defined threshold is exceeded. **NetContainer** [76] aims at exploiting cache locality to achieve maximum throughput and low latency for containerized VNFs. The authors first identify the random page allocation policy as the root cause of cache pollution. Then they build an estimation model based on the footprint theory to infer the cache access overhead and model the cache mapping problem as a Minimum Cost/Maximum Flow (MCMF) problem to decide the optimal memory buffer mappings. **NFV-throttle** [77] controls VNF overload by spreading software modules in NFV infrastructure. These modules dynamically monitor system conditions and selectively drop excessive packets to prevent VNFs from being overwhelmed. To ensure strict processing isolation for co-located containerized VNFs, **Iron** [78] introduces an enforcement mechanism to account for the time each VNF spent in kernel stack. Then it throttles or even drops the packets for the aggressive VNFs through a Linux scheduler or a hardware-based approach.

Profiling

Several platforms are dedicated to performance characterization. **NFV-vital** [79] is among the earliest efforts towards VNF performance characterization. It implements four components that can be seamlessly integrated into an ETSI-compatible NFV platform. With NFV-vital, users can specify their deployment and workload configurations, which are interpreted by the NFV-vital orchestrator to setup VNF and generate the workload accordingly. NFV-vital orchestrator receives statistics at runtime and performs posttest analysis. A similar design pattern is also adopted by several other platforms. **Gym** [80] is designed for automatic VNF performance benchmarking. It embraces a modular architecture with an extensible set of benchmarking tools and a simple messaging subsystem for remote procedure calls. It further provides a means for data post-processing and result visualization. **Du et al.** [81] builds a benchmarking framework on OPNFV clearwater platform. They leverage the Microservice architecture to integrate existing open-source tools to realize comprehensive tests under varied traffic loads and fault conditions. **ConMon** [82] is a distributed framework to monitor the performance of containerized VNFs. It dynamically discovers and monitors the communication between containers, and executes network monitoring functions inside a standby container interconnected through a virtual switch. **Symperf** [83] predicts VNF runtime performance and functional behaviors under various traffic dynamics through code analysis. **KOMon** [84] is a kernel-based online monitoring tool to measure packet processing times imposed by the target VNF. Instead of merely focusing on individual VNFs, several platforms capable of characterizing performance for SFCs. For example, **SFCPerf** [85] is purposed for automated SFC performance evaluation. Similar to NFV-vital, it has a control module that receives a user-specified configuration file and deploys the corresponding service chain in the target infrastructure. The control module subsequently collects concerning statistics to perform data analysis and visualization. **NFVPerf** [86] is able to detect performance bottlenecks on a service chain by monitoring inter-component communication. **Perfsight** [87] also aggregates execution information from various components along the data path to diagnose performance issues. **VBaaS** [88] profiles SFC performance for distributed NFVI. certification of VNFs and NFVI PoPs as performance profiles; fine-tuning choices of VBaaS results with tailor-made PoPs. VBaaS processes can be defined as simple tasks in common workflows of collection, synchronization, integration, and export for benchmark analysis. Places, where these tasks can take place, would be defined according to VBaaS profiles, orchestrator policies, and infrastructure capabilities

However, none of the aforementioned work is suitable to measure the performance of high-speed VNFs

¹The SNF here is not the same as the other SNF [73]

running at a multi-gigabyte rate. **OPNFV Barometer** [89] is designed to monitor the performance of DPDK-accelerated VNFs. It can be attached to the target VNF as a secondary process to gather shared processing information. **NFV-VIPP** [90] can be integrated into the DPDK-accelerated data plane to collect execution metrics and demonstrate the internals of an NFVI node. **BOLT** [91] defines the concept of the performance contract, which expresses the expected VNF or SFC performance as a function of critical parameters (e.g. execution instructions, CPU cycles, memory accesses). **DeepDiag** [92] monitors the runtime queuing statistics for each VNF and constructs an online impact graph to diagnose the cause of performance degradation. **CASTAN** [93] can parse VNF code and automatically generate the worst-case workloads that lead to degraded performance. It adopts symbolic execution to identify the worst code path and a CPU cache model to determine the specific memory access pattern that causes L3 cache invalidation. In its current form, CASTAN has successfully analyzed a dozen of DPDK-based network functions.

Secure execution

There is another group of platforms specifically devoted to developing secure VNFs for execution in untrusted environments. **vEPC-sec** [94] incorporates a variety of traffic encryption, validation, and monitoring schemes to safeguard cloud-based LTE VNFs. **SplitBox** [95] distributes VNF functionalities to multiple cloud VMs to obscure its internals from public cloud. **Embark** [96] allows VNFs to operate on encrypted data leveraging a special HTTPS encryption scheme. **BSec-NFVO** [97] introduces a blockchain-based architecture to protect NFV orchestration by auditing all the operations over the SFCs. Other platforms exploit Intel[®] Software Guard Extensions (SGX) [98] instruction codes to secure VNFs from memory reading attacks. In specific, **S-NFV** [99] concentrates on the protection of VNF states by stashing them into the shielded SGX memory region (*enclave*) to prevent unauthorized access or snooping. **TrustedClick** [100] and **ShieldBox** [101] extend the Click modular router to secure packet processing within SGX enclave, and rely on SGX remote attestation to verify code correctness. ShieldBox additionally integrates DPDK for high-speed packet processing and ring buffers to support SFC deployment. However, neither of them protects VNF states. Based on these previous endeavors, **SafeLib** [102] plans for a generic platform that can offer comprehensive VNF protection, including user traffic, VNF code, policy, and execution states. The authors propose to integrate DPDK and libVNF to support TCP functionalities without compromising performance. Its implementation is currently underway. **Safebricks** [103] and **LightBox** [104] also strive for comprehensive protection while sustaining reasonable performance. LightBox implements a virtual interface to ensure secure packet VNF I/O in SGX enclaves and adopts mOS stack to support stateful VNFs. It also implements a flow state management scheme by caching the states for active flows inside enclaves while encrypting and storing states of other flows in the untrusted host. A space-efficient hash algorithm is also incorporated for efficient flow classification. SafeBricks relies on the NetBricks platform for packet processing and VNF code protection. It partitions VNF code to minimize the trusted computing base in enclaves and performs packet exchanges across the trust boundary through a shared memory mechanism. It also supports deploying an entire SFC inside an enclave and leverages Rust primitives to isolate the VNFs. Note that it is unclear if SafeBricks supports TCP functionalities.

3.3 NFVI acceleration

With the rapid growth of traffic volume, NFV platforms are expected to deliver service without compromising performance, even under immense data rates. As the data plane, NFVI is inarguably the principle point of optimization. Many endeavors are concentrating on NFVI acceleration.

Single NFVI-PoP optimization

NetVM [105] aims at achieving high performance, flexible deployment, easy management, and guaranteed security altogether. It achieves line-rate processing through a zero-copy packet delivery mechanism based on shared memory and relies on a hypervisor-based switch to flexibly steer traffic between VNFs and the network. To ensure security, NetVM defines multi-level trust domains to limit the memory access of untrusted VNFs. A control plane is also implemented to facilitate system management by making decisions either locally or remotely. **OpenNetVM** [106] is based on NetVM architecture, but it adopts lightweight Docker containers to wrap VNFs. It also achieves more flexible traffic steering as both the VNFs and management entities can

make routing decisions. **NetML** [107] is built based on OpenNetVM and runs machine learning applications as VNFs. To unburden CPU and accelerate traffic processing, NetML further extends the CUDA library to exploit GPU for computation offloading. **ClickOS** [4] targets a high-performance, flexible, and scalable NFV platform with guaranteed resource/performance isolation and multi-tenancy. It utilizes the Click Modular Router [47] to build a wide range of VNFs in Xen-based uni-kernel VMs. A set of optimizations is performed on the hypervisor data path to boost the performance. The ClickOS VMs are instantiated from small images and take milliseconds to boot. Similarly, **HyperNF** [108] aims at achieving high performance and resource utilization. It advocates the consolidation of VNFs to share CPU cores and uses hypervisor-based virtual I/O to reduce synchronization overhead. Another platform akin to such design architecture is **ClimBOS** [109], which is based on Xen and ClickNF [46]. It is devised to help developers construct lightweight, isolated, and modular IoT backends. **MVMP** [110] is also based on DPDK and containers. It uses a virtual device abstraction layer for VNFs to multiplex the physical NICs and steer traffic. **NFF-Go** [111] is designed to build and deploy network functions in the cloud. It leverages DPDK to accelerate packet I/O and uses the Go language to facilitate development. The Go language is also expected to improve concurrency and guarantee safety. Moreover, it contains a scheduler to dynamically scale packet processing based on the current workload.

Some platforms mainly focus on SFC deployment and optimization. In **Flurries** [112], the authors introduce the concept of per-flow service provisioning, and implement a container-based NFV platform named Flurries that provides flexible service function chaining. In Flurries, each flow can be allocated to a corresponding SFC to allow for flow-level service customization and isolation. A combination of polling (for NICs) and interrupt (for VNFs) I/O scheme is also implemented to consolidate a large number of per-flow service chains on the server. **Microboxes** [113] concentrates on transport- and application-layer protocol consolidation for SFCs. It implements a modular, asynchronous TCP stack that can be customized on a per-flow basis to avoid redundant protocol processing on a service chain. It also provides a publish/subscribe-based communication mechanism to chain network functions and realize complex network services. **SNF** [73] is also implemented to eliminate redundant processing for SFC. It uses graph composition and set theory to decide the traffic classes for incoming packets before synthesizing per-class, functionally-equivalent, and optimized network functions. Likewise, **NFCcompass** [114] also strives for shortening the service chain by synthesizing VNFs and exploring parallelized execution. It additionally implements a graph-based model to minimize data transfer and balance traffic load. **SpeedyBox** [115] utilizes a table-based Match/Action technique to consolidate VNF actions at runtime and eliminate redundant processing along a service chain. **ParaBox** [116] explores to shorten SFCs by exploring parallelized VNF execution. It consists of a dependency analysis module to determine if some VNFs that can run in parallel, mirror/merge functions to distribute and aggregate packet copies across the parallelized VNFs. Similarly, **NFP** [117] also aims at exploring VNF parallelism for SFCs. It allows network operators to express SFC intent as policies and implements an orchestrator to analyze VNF dependencies and compile the policies into optimized network service graphs. The NFP infrastructure sequentially takes care of the execution of the service graphs and deals with low-level details such as traffic steering, load balancing, as well as the parallelized VNF execution. **Dysco** [118] explores session protocol mechanism for runtime reconfiguration of TCP service function chains with no packet loss and minimal service interruption. **MiddleClick** [119] aims at building high-speed, parallelized service chains. It allows network operators to define SFC intents which are synthesized into a flow table and managed by the framework. A session abstraction is also implemented to facilitate per-flow inspection. **ESFC** [120] is designed for flexible SFC resource management. It implements a controller to monitor the VNF status and enforce resource allocation policies using an asynchronous notification mechanism. A hash algorithm is devised to balance packets across VNF replicas while ensuring flow-level affinity. **SCC** [121] collects system statistics such as hardware/software performance counters, to identify the root causes of excessive SFC delays. Based on the profiling results, the SCC runtime addresses the performance bottlenecks accordingly by performing a set of optimizations including tuning the I/O batch size, adjusting scheduling policies, priorities, or time slices of the SFCs. **PA-Flow** [122] undertakes a packet aggregation approach to reduce traffic load for each VNF on an SFC. It embeds a module on each NFVI-PoP to perform transparent, network-aware, hop-by-hop packet aggregation/disaggregation to realize high-speed SFCs. Note that PA-Flow is designed to be compatible with state-of-the-art virtualization techniques and packet I/O frameworks. **Zorello et al.** [123] develop an in-path prediction engine to save energy for cloud-based NFVI. The proposed method employs a pre-trained machine learning model with the Dynamic Voltage-Frequency Scaling (DVFS) technology to

predict and specify the most suitable runtime CPU frequency. **HALO** [124] is designed to perform near-cache flow classification in software virtual switches with minimal impact on collocated VNFs. It explores last-level cache parallelization through the Non-Uniform Cache Access (NUCA) and Caching/Home Agent (CHA) on Intel multicore CPUs. The authors also extend the OS instruction with three table lookups to utilize the proposed HALO accelerators associated with each CHA.

Hardware-assist design

P4SC [125] and **P4NFV** [126] explore P4 language to accelerate SFC processing. P4SC leverages the P4 to construct and consolidate SFCs. It parses the SFC policies specified by network operators and converts them into a P4 program, which is subsequently deployed onto the P4-compatible hardware. P4NFV is designed for both hardware and software targets and supports runtime reconfiguration without violating state consistency. Albeit augmented with various software acceleration techniques, CPU cores might still fall short of performance. As a result, several platforms explore other hardware components for processing acceleration. **OpenANFV** [127] features automated provisioning and elastic management of network services. To overcome the performance issue incurred by computation-intensive VNFs, it delegates a subset of functionalities to programmable hardware. **UNO** [128] targets the SmartNICs (i.e. ASIC, FPGA, System on Chip) for computation offloading without violating the interoperability with the existing orchestration plane. While still relying on a centralized orchestrator to make global decisions, UNO selectively places new VNFs on the underlying SmartNICs to minimize host CPU usage, based on a placement algorithm considering local system status. It also actively reruns the algorithm and adjusts VNF placement between host and SmartNICs. To hide the complexity of SmartNICs from the remote orchestrator, UNO exposes a single-switch abstraction that correctly maps traffic steering rules to the host or SmartNIC switches. **NICA** [129] is a hardware-software co-designed platform for inline data path acceleration on SmartNICs with integrated FPGAs (F-NICs). The platform exposes a programming abstraction to give applications direct control over F-NIC accelerators and an I/O path virtualization to let multiple VMs share the F-NIC with guaranteed security and fairness. **FlowShader** [130], **GPUNFV** [131], **Gen** [132], **Grus** [133], and **G-NET** [134] seek to construct a concerted CPU-GPU pipeline to expedite SFC processing. FlowShader explores GPU and CPU for parallel processing. It leverages the standard Linux TCP/IP stack to classify incoming traffic, and specialized data structures to buffer messages and maintain per-flow information. After a batch completes, it invokes a flow scheduling algorithm to balance the buffered data to GPU or CPU for processing. Notably, each GPU thread executes the entire processing logic of a VNF (or SFC) to ensure flow-level parallelism. FlowShader further provides a general API to develop compatible VNFs between CPU and GPU domains. GPUNFV also employs flow-level parallelism and wraps a whole SFC inside a single GPU thread. Compared with FlowShader, it only exploits GPU for processing, yet devotes CPU for kernel-bypassing packet I/O and flow classification based on the 5-tuple. Gen features the dynamic scheduling of GPU threads to elastically scale VNF instances. It also supports runtime SFC modification by exploring features of the CUDA library. Also, it maintains a connection with a remote controller to orchestrate SFC execution. Grus reduces the processing latency through a set of data path optimizations, including coordinated access of the PCI-E bus between CPU and GPU, fine-grained scheduling of consolidated VNFs, and dynamic batching. G-NET deploys network functions in VMs and offloads VNF processing to GPU. It manipulates the GPU context to allow for spatial GPU sharing across manifold VNF kernels and leverages safe pointers to guarantee GPU memory isolation. A scheduling algorithm is designed to calculate the per-SFC cost and optimize the GPU resource sharing.

4 Design Space

In this section, we explore the design space, identify the critical design issues, and summarize different choices adopted by existing NFV platforms. Specific design choices of each platform have been illustrated in Table 1. Note that in general there is no superior choice over the others, and it is only a matter of use cases and application context.

Platform	MANO plane					Service layer					NFV infrastructure											
	High-level API		PE	State redistribution		Execution model		TCP	VNF I/O		Packet I/O	VNF connect		Virtualization technique			Other optimizations					
	GPL	DSL		SM	MA	RTC	PL		Poll	ITR		VS	CI	VM	CT	PR	BA	ZC	PE	CO	HO	
OpenBox	✓		✓		✓	✓					Kernel			✓								✓
E2		✓	✓		✓	✓		✓			DPDK	✓										✓
SDNFV			✓			✓				✓	DPDK		✓	✓			✓	✓	✓			✓
Slick	✓		✓			✓					Kernel					✓						✓
Eden		✓	✓			✓					Kernel		✓			✓						✓
MicroNF			✓								DPDK	✓		✓	✓							✓
μNF		✓			✓					✓	DPDK		✓		✓	✓	✓	✓				✓
Metron	✓		✓	✓		✓					DPDK	✓			✓	✓	✓	✓				✓
Flurries	✓									✓	DPDK				✓	✓	✓	✓				✓
MicroBoxes	✓										DPDK				✓	✓	✓	✓				✓
OpenNF				✓							Kernel				✓	✓	✓	✓				✓
NFVactor	✓			✓		✓				✓	DPDK	✓			✓		✓	✓	✓			✓
ClickNF	✓					✓					DPDK				✓	✓	✓	✓				✓
Flick		✓				✓					DPDK				✓	✓	✓	✓				✓
NetStar	✓				✓	✓					DPDK		✓		✓	✓	✓	✓				✓
S6	✓				✓	✓					DPDK	✓			✓	✓	✓	✓				✓
StatelessNF	✓				✓	✓					DPDK				✓	✓	✓	✓				✓
libVNF	✓				✓						netmap	✓		✓		✓	✓	✓				✓
NFMorph											kernel					✓	✓	✓				✓
NetVM		✓									DPDK		✓		✓	✓	✓	✓				✓
OpenNetVM	✓					✓					DPDK	✓		✓		✓	✓	✓				✓
NetML	✓					✓					DPDK	✓			✓	✓	✓	✓				✓
NetBricks	✓					✓					DPDK	✓			✓	✓	✓	✓				✓
ClickOS	✓					✓					DPDK	✓			✓	✓	✓	✓				✓
HyperNF											netmap	✓		✓		✓	✓	✓				✓
IOVTee											netmap			✓		✓	✓	✓				✓
CHC											DPDK		✓	✓	✓	✓	✓	✓				✓
NICA	✓				✓					✓	VMA		✓	✓	✓	✓	✓	✓				✓
Polycube	✓										VMA			✓	✓	✓	✓	✓				✓
NFP											eBPF			✓		✓	✓	✓				✓
ParaBox							✓				DPDK		✓		✓	✓	✓	✓				✓
NFVNice	✓										DPDK	✓			✓	✓	✓	✓				✓
PA-Flow											DPDK	✓		✓	✓	✓	✓	✓				✓

Table 1: Design choices for most of the existing NFV platforms.

4.1 MANO plane

High-level API

Most of the existing NFV frameworks provide high-level APIs to specify service policies or smooth the process of VNF development. These APIs can generally come as either **Domain-Specific Language (DSL)** or **General-Purpose Language (GPL)**. GPLs such as C, C++, Java, and Python are mature programming languages capable of solving problems in multiple domains. They are shipped with multitudinous control primitives, miscellaneous data structures, and flexible operating patterns. Most of the existing NFV platforms adopt GPL. For example, OpenNF relies on a collection of northbound C++ functions to develop control applications. NFVNice exposes a C library named “libnf” to perform I/O operations asynchronously and to monitor the workload (e.g. arrival rate, processing time) for each VNF. OpenBox exposes its northbound Java API for network operators to specify processing logic and subscribe to particular events. Slick provides a programming abstraction that allows developers to write custom VNFs and specify traffic steering policy in Python. ClickNF provides a standard socket API and a zero-copy interface as C++ functions to interact with its transport layer. S6 exposes a programming API to manipulate states across the shared object space. NICA introduces the “ikernel” programming abstraction over TCP/UDP sockets to facilitate user-space VNF development. GPUNFV exposes CUDA-based API to assist per-flow state abstraction and construct GPU kernel code. FlowShader and G-NET provide a CUDA-based API to develop VNFs compatible with both GPU and CPU semantics. Compared to GPLs, DSLs provide higher-level optimized abstractions for specific problems, and they usually operate in an environment with limited operation patterns and restricted resource usage. Several platforms incorporate DSL for network service development. For example, authors of [41] propose flick language that supports parallel execution and safe resource sharing. In addition to basic primitives such as event handling and common data types, flick can deserialize input packets into application-specific data types and vice versa, bringing application semantics into VNF development. E2 allows network operators to specify SFCs using a policy language, SONATA’s development toolchain allows developers to specify network services using DSL. On the Eden platform, network operators specify service policies in the F# language, as it makes the VNF safety checking process straightforward.

Placement

During the VNF placement phase, existing NFV platforms usually resort to a Placement Engine (PE) that conducts a set of **pre-processing** operations to merge and shorten SFCs before actually **placing** them to the anticipated NFVI PoPs with specific objectives. For instance, based on the specified network service description and infrastructural specification, CoMb seeks to consolidate each SFCs on a single NFVI-PoP by solving an optimization model. OpenBox relies on a graph merging algorithm to optimally deploy the VNFs to the user-specified NFVI-PoPs. Through the OpenBox northbound interface, a developer can specify her VNF in the form of a processing graph along with the intended deployment domain or NFVI-PoP. The OpenBox controller parses the graphs intended for the same location and merges them into a single graph without violating their processing logic. Slick provides a holistic solution for VNF placement and traffic steering. The Slick controller employs an inflation heuristic to consolidate VNFs with minimum cost and uses a placement algorithm to deploy the consolidated VNFs. Traffic steering rules are also configured on each switch to realize the intended routes and processing sequence for each flow. E2 employs similar approaches to merge and synthesize multiple service graphs to reduce processing redundancy. Then it models VNF instance placement as a graph partition problem over the COTS servers and employs a modified Kernighan-Lin algorithm to minimize the inter-server traffic. SDNFV formulates the service placement problem as a mixed-integer linear program (MILP) to maximize resource utilization. Then the authors develop a heuristic algorithm to solve the placement of VNFs while configuring the related traffic routes based on the service graph specified by the network operator. Metron uses SNF to optimize its input processing graph and construct a synthesized graph, which is subsequently split into a stateful subgraph and a stateless subgraph. The stateful graph is deployed on COTS servers selected by Metron’s server selection scheme. The stateless graph is then offloaded to network elements based on the deployment locations of the stateful graph. MicroNF performs dependency analysis for the elements instead of VNFs, and reconstruct the service graph to reduce redundant processing and improve resource efficiency. It subsequently places the modularized SFCs to the COTS servers by resolving a 0-1 Integer Programming to minimize the inter-VM overhead. The μ NF orchestrator also constructs an optimal forwarding graph by consolidating the same types of VNFs, but the objectives based on which the VNFs are placed across COTS servers are not indicated by the authors.

State redistribution

With the proliferation of stateful VNFs, it is hence critical to keep the processing states consistently upon instance scaling. However, it is extremely challenging to simultaneously satisfy all the state management requirements, e.g. flow affinity preservation, timely state synchronization, correct processing, minimal service interruption, etc, especially upon VNF scaling or instance failover. Strategies adopted by existing NFV platforms can be generally classified to **State Migration** (SM) and **Migration Avoidance** (MA). Among the platforms adopting state migration, OpenNF provides the most robust scheme by allowing control applications to move, copy, and share states with different granularities between two VNF replicas. In specific, it implements state moving and copying operations to facilitate state migration. The move operation applies cautious coordination between source/destination instances and the last shared on-path OpenFlow switch to achieve lossless, order-preserving state migration. The copy operation allows for state clones in an eventually consistent manner, while the share operation guarantees strong consistency by instructing the controller to capture all events from the last shared switch, sending them to the corresponding VNF instances for processing, and applying state update sequentially in the global scope. MicroNF, UNO, and OpenBox also advocate this solution for state coordination. Split/Merge also relies on the SDN mechanism to migrate partitioned states and flows across multiple VNF replicas. Upon a scaling decision, it firstly instructs SDN to suspend traffic flow for all replicas, then transfers relevant states across the replicas and configures routes for the affected flows, and finally resumes the traffic flow. This approach preserves flow affinity, but the in-transit packets for the affected flow are lost. Metron migrates states by traffic classes. When an SFC is overloaded, Metron splits its traffic classes into two groups, and simply duplicates only states of the migrated group to the new SFC instance. Compared to OpenNF, this scheme might result in runtime inconsistency and waste of memory. TFM migrates states between two VNFs by instantiating a TFM box at each of them. Then TFM controller transmits flow states to the destination VNF and updates routing tables of the in-path switches to redirect incoming packets of the migrating flows to the destination VNF. The TFM boxes at both VNFs buffer all the in-transit packets, which are fed to the destination VNF according to

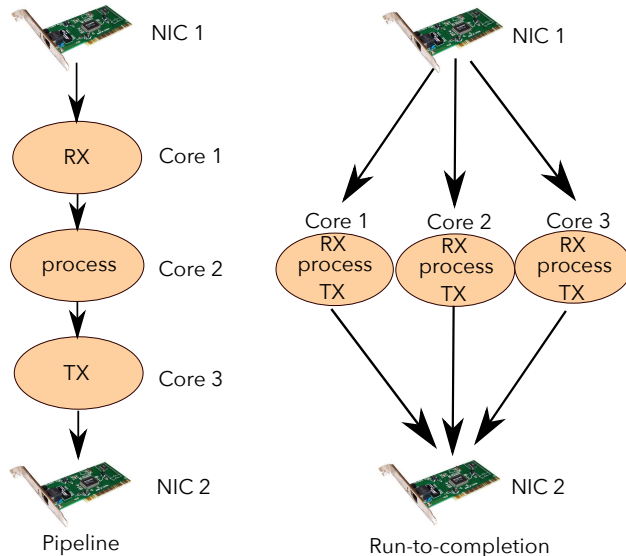

Figure 3: Execution models of a simple VNF instance sitting between two physical NIC. It consists a sequence of three elements, namely RX, processing, and TX.

the receiving order after state migration. In contrast, some other platforms adopt the migration avoidance strategy to avoid state migration overhead. For instance, upon scaling out, E2 splits incoming traffic based on their flow identifiers (e.g. 5-tuple) on the original VNF and identifies new flows that need to be directed to the newly instantiated VNFs. Then the E2 manager configures routing tables of the in-path software and hardware switches to steer new flows from the original VNF to new instances. Existing flows will keep being served by the original VNF until termination. Although the traffic direction phase might incur extra delay, the authors believe that this overhead is merely transient and this approach outperforms state migration approaches. MicroNF employs a "Push-Aside" scaling strategy in which the overloaded element kicks its upstream/downstream element to the neighboring VMs to spare resources. Therefore, instead of migrating states, MicroNF opts for moving VNFs' elements, avoiding state migration. But it is unclear whether the element migration phase can cause any data loss or inconsistency. The most common migration avoidance strategy is externalizing the processing state. StatelessNF, CHC, and libVNF keep VNF processing states in high-speed external data stores to avoid the migration cost. In particular, libVNF maintains key-value data stores at multiple levels: a local data store shared by all threads of a single VNF, a global store shared across multiple VNF replicas and a local cache for recently accessed data from the global store.

4.2 VNF plane

To implement efficient VNFs, NFV platforms are required to consider the following design choices:

Execution model

In NFV domain, the VNF (or SFC) execution model can be classified into **Run-To-Completion (RTC)** and **Pipeline (PL)**. In the RTC model, all the VNFs of a given SFC run on a single thread, whereas in the pipeline model, each VNF instance is pinned to a separate thread, as illustrated in Fig. 3. The performance of either model is highly dependent on processing complexity and input workload, which lead to a different level of cache and memory access patterns. In general, the RTC model demonstrates better throughput and latency when executing simple VNFs and/or short SFCs, since it obviates the inter-core transfer overhead [31]. It may also require fewer worker cores than the pipeline model. However, the edge of RTC fades with complex VNFs and/or lengthy SFCs, in which cases a large amount of data/instructions and context switches might precipitate persistent L1/L2 cache misses. VNFs running in the RTC model are also more difficult to be individually scaled based on input load. As a result, there is no superior solution

and distinctive NFV platforms usually make choices based on their specific architectures. In [135], the authors advocate a hybrid of execution model to take advantage of these two models while avoiding their shortcomings. Some platforms adopt the RTC model mainly because they only execute lightweight VNFs or trimmed SFCs in software. For instance, NetBricks, ClickNF, ClickOS, NetStar, NFVector, and SafeBricks execute VNFs as processes in the RTC model to avoid inter-core transfer overhead. Metron offloads part of its SFCs to the in-path hardware equipment, executing the trimmed SFC tasks in the RTC model on COTS servers. CoMb executes an entire VNF or SFC in a single core to avoid inter-core synchronization overhead. GPU-based solutions also adopt the RTC model due to the intrinsic inefficiency of the pipeline model on GPU architecture [132]. Consequently, FlowShader, GPUNFV, and Gen embed one integral SFC in a single GPU thread. Other platforms employ the pipeline model. For example, μ NF and MicroNF decompose VNFs or SFCs into modular, fine-grained, loosely-coupled packet processing tasks (or elements) so that resources can be precisely allocated to scale individual elements. Flick allows for pipelined execution of individual tasks of its VNFs. PA-Flow is designed for SFCs that are distributed across NFVI-PoPs and run in pipeline mode. The poll-mode VNFs scheduled by UNiS also run in pipelines constructed with DPDK ring buffer. ShieldBox also adopts DPDK ring buffers to VNFs across multiple SGX enclaves. StatelessNF executes VNFs in pipelines. Each pipeline consists of a polling thread, a lockless queue, and a processing thread.

TCP functionality

As stateful VNFs have become an important building block in the NFV ecosystem, it is worth pointing out existing platforms that implement or integrate TCP/IP stack to support stateful VNFs at layer 4 or beyond. ClickNF is equipped with a full-fledge modular TCP stack to facilitate the end-host application development. Microboxes comes with a modular, customizable TCP stack that can be shared among a group of VNFs to eliminate redundant processing. NICA even implements a simplified TCP stack in SmartNICs to enrich its in-path processing features. xOMB stack also implements simple functions such as TCP connection termination. Instead of developing TCP functionalities from scratch, some platforms choose to directly incorporate third-party solutions. For example, Flick integrates the high-speed kernel-bypassing mTCP stack [136] to realize transport layer VNFs, NetStar directly employs a third-party user-space TCP stack with future/promise abstraction. libVNF is designed to be generic by integrating both the standard networking stack and mTCP. Besides, all the NFV platforms using the kernel TCP/IP stack are granted TCP functionalities by default. In particular, Polycube directly cooperates with the kernel TCP/IP stack to build complex SFCs.

VNF I/O

Just like the execution model, there are also two alternative means for VNFs to perform packet I/O, namely **Polling** and **Interrupt (ITR)**. VNFs running in polling mode keep querying the NICs or upstream VNFs for data, which normally renders better performance at the cost of wasted CPU cycles and increased energy consumption. Interrupt-based I/O usually does not entail wasted resources but suffers from performance losses due to interrupt propagation delay and cache line warm-up. In existing NFV platforms, UNO, CHC, NFVector, and StatelessNF execute VNFs in poll-mode to enhance performance. UNiS is tailored to schedule poll-mode VNFs by manipulating the Linux real-time scheduler. Flick, ClickNF, NFVNice, xOMB, and libVNF execute VNFs in interrupt mode.

Secure execution

At present, it is increasingly common for VNFs to be delegated for execution in untrusted environments such as public or third-party clouds. Consequently, both traffic data and VNF information are exposed to different cyber attacks. Existing NFV platforms generally secure the execution of VNFs with either **Encryption approach** or **Shield Execution**. Platforms adopting an encryption approach usually leverage various cryptographic schemes to allow VNFs to operate directly on encrypted network traffic. On the other hand, platforms adopting shield execution commonly run VNFs in private memory regions called enclaves. Contents inside an enclave are strictly protected and cannot be accessed by any external process. Compared to shield execution, encryption approaches generally incur higher overhead, imposed by the complex cryptographic computation, and support a limited set of functionalities. The only advantage is that they are not reliant on trusted hardware such as Intel SGX.

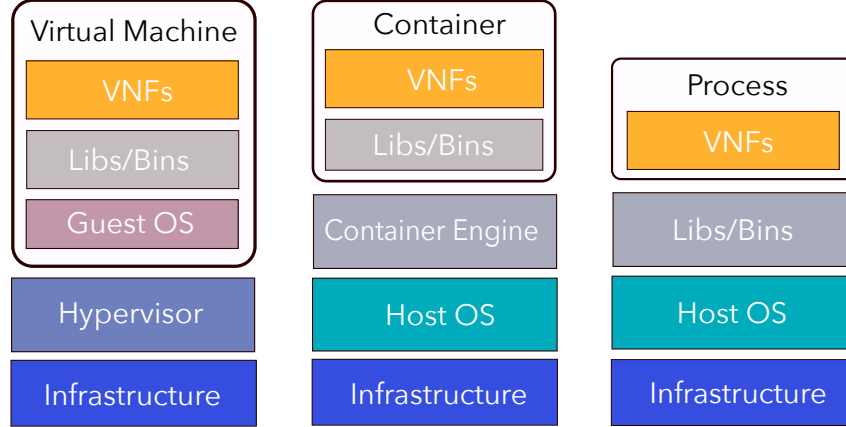

Figure 4: State-of-the-art virtualization techniques

4.3 NFVI

Virtualization technique

As the central point of any NFV platform, existing implementations typically deploy network functions inside **Virtual Machines (VMs)**, **Containers (CT)**, or simply as bare-metal **Processes (PR)**. As illustrated in Fig. 4, they realize virtualization at different layers in the commodity hardware infrastructure, and therefore present different degrees of isolation and resource requirements. VM is a hardware-level virtualization technique that relies on the Virtual Machine Monitor (VMM) or hypervisor, a firmware that offers a virtual platform to accommodate a variety of guest operating systems, on which different applications or VNFs execute². Hypervisors also supervise and coordinate the VM instances for efficient hardware resource sharing across them. As the most traditional approach for virtualization, VM-based NFV platforms are commonplace. For example, NetVM, NICA, and SDNFV exploit KVM-based VMs, Split/Merge, HyperNF, and FlowOS build VNFs inside Xen-based VMs. However, traditional VMs commonly incur heavy resource demands, huge memory footprints, and high migration costs. To cope with these issues, ClickOS and CLIMBOS adopt unikernel VMs, which are essentially minimalistic VMs that are small, agile, and fast-to-boot. The advent of containerization techniques, such as LXC and Docker, bestow another option. Compared to VM, the container is an OS-level virtualization technique with a much smaller memory footprint and shorter instantiation time, much higher deployment density (up to thousands per server), and lower redistribution cost. Nonetheless, containers are not completely insulated from the host OS, they thus cannot grant the same level of isolation and security as VMs. In terms of performance, both of them can sustain line rate processing leveraging particular I/O paths and networking techniques [137]. At present, many existing NFV platforms opt for containerized VNFs. For instance, OpenNetVM, Flurries, MicroBoxes, NFVNice, MVMP, NFP, ParaBox, MVMP, statelessNF, NFVactor, and GNFC execute their VNFs inside Docker containers. CHC and Iron run VNFs in LXC containers. Aside from VMs and containers, a set of NFV platforms deploy VNFs as processes or threads to trade isolation for performance. These platforms usually assume trusted VNFs and infrastructure. For example, NetBricks, ClickNF, libVNF, and SafeLib execute VNFs as processes. OPNFV barometer is designed to profile the performance of the VNFs running as DPDK processes. SplitBox executes VNFs as processes inside FastClick. GPUNFV, Gen, FlowShader, Grus, and G-NET execute VNFs or SFCs as GPU threads. Notably, some platforms opt for multiple choices or introduce hybrid solutions. For example, NFV-VIPP and PF-Flow can be integrated into any DPDK-accelerated VNFs running inside VMs, containers, or as bare-metal processes. VNFs in OpenNetVM and μ NF can be deployed either as processes or inside containers. MicroNF even runs containers inside VMs probably to improve security.

²Note that there is another kind of hypervisor that operates at OS-level (namely hosted hypervisor), we exclude from our discussion as they are rarely used by existing NFV platforms.

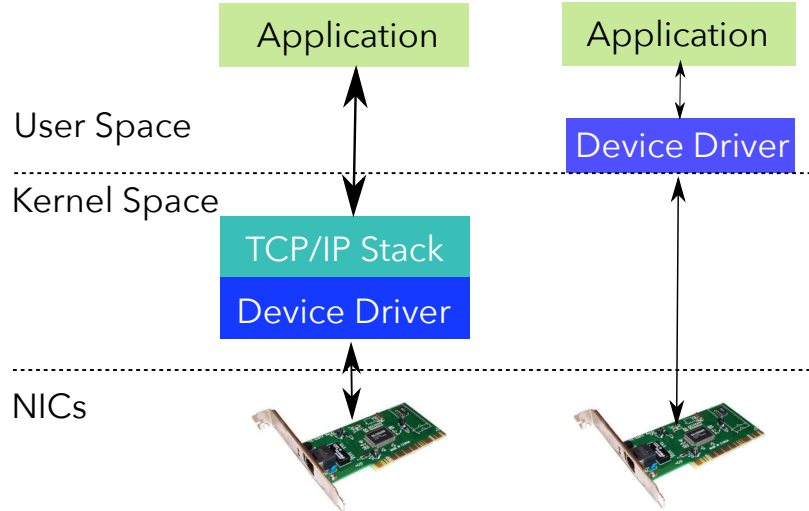

Figure 5: Packet I/O: Kernel-based vs. Kernel-bypassing

VNF interconnects

NFV platforms achieve cost-efficiency by consolidating multiple instances of VNFs inside individual COTS servers. These VNFs are then purposely concatenated to form specific SFCs. Existing NFV platforms interconnect local VNFs using either state-of-the-art **Virtual Switches (VS)** or employ **Custom Implementations (CI)**. Software virtual switches are widely used as NFV data plane for efficient traffic steering. For instance, E2, ParaBox, and NFVactor reuse BESS [138] as data plane to interconnect VNFs or runtimes, while ClickOS and HyperNF extend VALE switch [139]. CoMb customizes the Click Modular Router [47] to classify and forward packets between VNFs of the same service chain. Metron, MiddleClick, SCC, and SplitBox leverage FastClick [140] to ferry packets between VNFs and the network. Split/Merge, TFM, and MicroNF employ Open vSwitch (OVS) [141] for VM-networking, while UNO and PA-Flow employ OVS-DPDK [142]. Note that UNO steers packets at both the COTS server and SmartNIC. More details about the performance of the aforementioned software switches can be found in [137]. Rather than adopting third-party solutions, G-NET uses a bespoke software switch to route packets between VNFs and physical NICs.

Packet I/O frameworks

Packet I/O frameworks can be classified into **Kernel-based** and **Kernel-bypassing** approaches, as illustrated in Fig. 5. Traditionally, network applications rely on the general-purpose OS kernel stack for packet I/O. For instance, Eden, FlowOS, and NetContainer employ kernel-based I/O to seamlessly utilize the rich features of the kernel stack. However, the OS kernel imposes non-negligible overhead on the packet data path, making software applications fail to sustain high-speed processing [140]. To overcome this bottleneck, kernel-bypassing frameworks such as DPDK [143] and netmap [144] are proposed. They commonly embody data path optimization routines such as zero-copy delivery to avoid staging packets in kernel space, preallocated packet buffers to eschew runtime memory allocation, and batch processing to amortize the overhead of accessing hardware. netmap is compatible with the standard kernel stack as it still incorporates system calls for data validation and interrupt-based packet reception. DPDK employs complete kernel bypassing and dispatches poll-mode drivers to enhance performance. DPDK further exposes a rich collection of APIs and primitives to simplify application development. As shown in Tab. 1, most of the existing NFV platforms adopting DPDK for packet I/O from physical NICs. For example, Flick, ClickNF, NetStar, NetVM, OpenNetVM, CoNFV, OPNFV barometer, NFV-VIPP, SafeLib, SplitBox, UNO, GPUNFV, Gen, Grus, G-NET all leverages DPDK for packet I/O. netmap is used by ClickOS and HyperNF. NICA and CHC rely on Mellanox Message Accelerator (VMA) [145], another kernel-bypass packet I/O framework with standard

POSIX socket APIs and user-space networking library. Note that even if the traditional kernel-based approach fails to render comparable performance as kernel-bypassing stacks, it can still be useful when the VNFs are not I/O intensive or the cost to set up a kernel-bypassing stack becomes too high. Furthermore, a kernel-based high-speed packet I/O framework named eBPF is adopted by the Polycube platform for packet I/O to achieve multi-gigabyte processing. libVNF is a general platform that employs kernel, DPDK, and netmap altogether so that users can make choices according to their respective needs.

4.4 Other design choices

As discussed in our previous work [146], there is a large assortment of acceleration techniques for high-speed packet processing. In this part, we pick the most commonly utilized techniques and enumerate their adoption by existing NFV platforms. The optimizations we consider including zero-copy, batching, memory pre-allocation, instruction/data prefetching, parallel execution, CPU cache optimization, and computation offloading. Although these optimizations are commonly applied by the preceding packet I/O techniques, we discuss their applications in other parts of the NFV architecture.

Zero Copy (ZC)

In the high-speed packet processing domain, runtime memory copy is an expensive operation that usually leads to unbearable overhead. For the sake of performance, many existing NFV platforms deliver packets across VNFs or memory boundaries in a zero-copy manner, by copying only their associated packet descriptors. For example, μ NF implements a zero-copy port abstraction that only exchanges packet addresses instead of copying full packets between VNFs. The TCP stack of ClickNF exposes zero-copy interfaces to interact with user-space VNF. NetVM and OpenNetVM implement a zero-copy packet mechanism through shared memory. NICA leverages ring buffers for zero-copy message exchange between the F-NIC units and the user-space VNFs. GPUNFV and NetML achieve zero-copy packet delivery across CPU and GPU boundary through CUDA's page-lock memory. G-NET's switch also employs a zero-copy design.

Batching (BA)

In high-speed packet processing frameworks, I/O batching is widely used to amortize the overhead of accessing the physical NIC over multiple packets. This technique is also employed by some NFV platforms to enhance performance. For example, NFNice and EdgeMiner batch the I/O interrupts to amortize VNF wakeup overhead. SCC handles the system calls of VNF I/O in dynamic batches to reduce the overhead of context switches. The VNFs on the μ NF platform perform packet I/O in batches through the intermediate ring buffers. The TCP stack of ClickNF exchanges packets with the user-space VNFs in batches. StatelessNF aggregates multiple read/write requests to the data store into a single request to amortize the overhead of remote procedure call (RPC). SafeBricks implements an in-enclave module for batched packet I/O from/to the host. LightBox adopts packet batching to amortize the system call overhead. GPUNFV, Grus, FlowShader, G-NET, and Gen deliver packets between CPU and GPU in dynamic batches.

Pre-allocation

As memory allocation at runtime remains an expensive operation. In addition to the pre-allocated packet buffers and descriptors by some packet I/O techniques, existing NFV platforms usually pre-allocate a particular memory region to stage and reuse other relevant packet processing data structures. For example, libVNF pre-allocates memory pools for its per-core, persistent request objects, and lock-free packet buffers. Flick pre-allocates its task graphs and queues. S6 pre-allocates a pool of the cooperative, user-space, per-flow micro-threads to avoid the dynamic thread creation/deletion overhead. ShieldBox pre-allocates packet descriptor memory. LightBox pre-allocates state management data structures.

Parallel Execution (PE)

To take advantage of the multicore CPUs, many platforms explore possibilities for parallelization. μ NF performs a dependency analysis on its forwarding graphs to identify parallelize VNFs. Consecutive VNFs

are deemed parallelizable if they perform read-only operations or update disjoint packet regions. Then these VNFs are assigned independent CPU cores to process packets. A reference counter is attached as meta-data to avoid out-of-order operations from downstream VNFs. Likewise, SDNFV allows multiple VNFs to access a packet in parallel using a reference counter embedded in the packet descriptor. Eden exposes a concurrency model that creates consistent state copies for multiple VNFs to execute in parallel in the Eden enclave. CoMb allocates each SFC an independent shim layer to allow for parallel execution of multiple SFCs. Flick instantiates a new task graph for each new connection and schedules the tasks of these graphs onto multiple worker cores in parallel. ClickNF utilizes the Receive-Side Scaling (RSS) of physical NICs to distribute incoming packets to multiple cores with flow-level affinity guaranteed. NetStar builds VNFs with a share-nothing thread model and distributes incoming packets to different threads for paralleled multicore processing. libVNF is built with multicore scalability of VNF and uses per-core data structures to avoid inter-core communication which can hamper the multicore scalability of a VNF.

Cache Optimization (CO)

Modern CPUs are equipped with hierarchical caches between their cores and the main memory. Cache misses result in extra access to other cache levels or the main memory, which significantly slows down the processing speed. Many existing NFV platforms are aware of this issue and explore opportunities for cache optimization. NetContainer aims at exploiting cache locality at inter-flow and intra-flow levels for NFV workload and leverages page coloring technique to aggregate buffer pages to separate cache regions to avoid cache contention. ResQ exploits Intel Cache Allocation Technology with corresponding buffer sizing to eliminate last level cache invalidation while ensuring performance isolation. LightBox adapts cache line protection techniques to reduce cache miss rate. μ NF performs cache-line pre-fetching in batches to increase the cache hit rate. Some platforms also make their critical internal data structures cache-optimized. For example, the request objects of libVNF are cache-optimized, all the per-core data structures of ClickNF are cache-aligned.

Hardware Offloading (HO)

Hardware computation offloading is widely adopted by existing NFV platforms to alleviate the pressure of COTS servers. Potential resources to offload computing tasks including GPU, smartNICs, in-path programmable network equipment, or other specialized accelerators. E2 manager maintains a connection with OpenFlow switch and cognitively offloads simple VNF to unburden the servers. Likewise, Metron offloads stateless operations to the in-path programmable NICs and switches. OpenBox and Eden also support hardware implementation of their forwarding plane to accelerate processing. OpenNetVM and OpenANFV incorporate programmable NICs or FPGAs for computation offloading. ClickNF explores common NIC features to perform TCP/IP checksum offloading, TCP segmentation offloading (TSO), and large receive offloading (LRO). GPUNFV, Gen, FlowShader, Grus, NetML, and G-NET all achieve performance boost by completely or partially offloading their computation tasks to GPU. SmartNICs are commonly equipped with programmable, multi-core processors and an integrated operating system, make them ideal to execute computation tasks. UNO and NFMorph explore smartNICs to offload VNFs, forwarding rules, flow tables, and crypto/compression operations. NICA leverages the inline processing of FPGA on smartNICs to accelerate data plane processing. The “ikernel” programming abstraction of NICA grants user-space VNFs direct control over the computations in SmartNICs. CHC allows VNFs to offload operations to the external state store to speed up shared state updates. Another flavor of hardware computation offloading comes with reusing a computation result. For instance, OpenNetVM and NFMorph reuse the Receive-Side Scaling (RSS) hash value computed by the NIC for traffic classification at a later stage, SDNFV caches flow table lookup results in packet descriptors to be reused by the VNFs.

5 Conclusion

As an emerging paradigm to shift network management and service provisioning, NFV is expected to revolutionize the next-generation telecommunication networks. To accelerate the innovation and commercial adoption of NFV, a large spectrum of platforms have been implemented in the last six years. While sharing

the ultimate objective of promoting NFV, they usually tackle divergent problems in the NFV eco-system and embrace disparate design choices to achieve different performance metrics or service layer agreements, and little work has been devoted to interpreting this huge collection of platform implementations. In this paper, we present a comprehensive survey of existing NFV platforms. After giving a brief review of the typical NFV architecture, we present our taxonomy on existing NFV platforms based on their design purposes. Then we explore the design space and investigate the various choices individual NFV platforms opt for to tackle different implementation challenges. We believe this work is comprehensive enough to provide a first-hand guideline for network operators, service providers, and developers to choose the most suitable NFV platforms or reinvent the wheel based on their specific requirements.

Acknowledgments

This work has been carried out at LINCS (<http://www.lincs.fr>). We would like to thank Dr. Priyanka Naik for her valuable feedback.

References

- [1] T. Zhang, H. Qiu, L. Linguaglossa, W. Cerroni, and P. Giaccone, “NFV platforms: Taxonomy, design choices and future challenges,” *IEEE Transactions on Network and Service Management*, 2020.
- [2] J. Sherry, S. Hasan, C. Scott, A. Krishnamurthy, S. Ratnasamy, and V. Sekar, “Making middleboxes someone else’s problem: network processing as a cloud service,” *ACM SIGCOMM CCR*, 2012.
- [3] V. Cisco, “Cisco visual networking index: Forecast and trends, 2017–2022,” *White Paper*, 2018.
- [4] J. Martins, M. Ahmed, C. Raiciu, V. Olteanu, M. Honda, R. Bifulco, and F. Huici, “Clickos and the art of network function virtualization,” in *USENIX NSDI*, 2014.
- [5] N. McKeown, T. Anderson, H. Balakrishnan, G. Parulkar, L. Peterson, J. Rexford, S. Shenker, and J. Turner, “Openflow: enabling innovation in campus networks,” *ACM SIGCOMM CCR*, 2008.
- [6] R. Mijumbi, J. Serrat, J.-L. Gorricho, N. Bouten, F. De Turck, and R. Boutaba, “Network function virtualization: State-of-the-art and research challenges,” *IEEE Communications Surveys & Tutorials*, 2015.
- [7] “ETSI - Welcome to the World of Standards!” <https://www.etsi.org/>, 2019.
- [8] X. Li and C. Qian, “A survey of network function placement,” in *IEEE CCNC*, 2016.
- [9] J. G. Herrera and J. F. Botero, “Resource allocation in nfv: A comprehensive survey,” *IEEE TNSM*, 2016.
- [10] D. Bhamare, R. Jain, M. Samaka, and A. Erbad, “A survey on service function chaining,” *Elsevier JNCA*, 2016.
- [11] W. Yang and C. Fung, “A survey on security in network functions virtualization,” in *IEEE NetSoft*, 2016.
- [12] N. F. S. de Sousa, D. A. L. Perez, R. V. Rosa, M. A. Santos, and C. E. Rothenberg, “Network service orchestration: A survey,” *Computer Communications*, 2019.
- [13] R. Mijumbi, J. Serrat, J.-L. Gorricho, S. Latré, M. Charalambides, and D. Lopez, “Management and orchestration challenges in network functions virtualization,” *IEEE Communications Magazine*, 2016.
- [14] B. Yi, X. Wang, K. Li, M. Huang *et al.*, “A comprehensive survey of network function virtualization,” *Computer Networks*, 2018.
- [15] G. ETSI, “Network Functions Virtualisation (NFV): Architectural framework,” *ETSI Gs NFV*, 2013.

- [16] P. Bosshart, D. Daly, G. Gibb, M. Izzard, N. McKeown, J. Rexford, C. Schlesinger, D. Talayco, A. Vahdat, G. Varghese *et al.*, “P4: Programming protocol-independent packet processors,” *ACM SIGCOMM CCR*, 2014.
- [17] A. Császár, W. John, M. Kind, C. Meirosu, G. Pongrácz, D. Staessens, A. Takács, and F.-J. Westphal, “Unifying cloud and carrier network: Eu fp7 project unify,” in *IEEE/ACM UCC*, 2013.
- [18] J. Soares, C. Gonçalves, B. Parreira, P. Tavares, J. Carapinha, J. P. Barraca, R. L. Aguiar, and S. Sargento, “Toward a telco cloud environment for service functions,” *IEEE Communications Magazine*, 2015.
- [19] “CloudBand: Adopt lean operations and increase business agility,” <https://www.nokia.com/networks/solutions/cloudband/>, 2019.
- [20] R. Cziva and D. P. Pezaros, “Container network functions: bringing NFV to the network edge,” *IEEE Communications Magazine*, 2017.
- [21] L. Li, K. Ota, and M. Dong, “DeepNFV: A lightweight framework for intelligent edge network functions virtualization,” *IEEE Network*, 2018.
- [22] A. Lombardo, A. Manzalini, G. Schembra, G. Faraci, C. Rametta, and V. Riccobene, “An open framework to enable netfate (network functions at the edge),” in *IEEE NetSoft*, 2015.
- [23] S. Dräxler, H. Karl, M. Peuster, H. R. Kouchaksaraei, M. Bredel, J. Lessmann, T. Soenen, W. Tavernier, S. Mendel-Brin, and G. Xilouris, “Sonata: Service programming and orchestration for virtualized software networks,” in *IEEE ICC Workshops*, 2017.
- [24] H. Ballani, P. Costa, C. Gkantsidis, M. P. Grosvenor, T. Karagiannis, L. Koromilas, and G. O’Shea, “Enabling end-host network functions,” in *ACM SIGCOMM CCR*, 2015.
- [25] A. Bremler-Barr, Y. Harchol, and D. Hay, “OpenBox: a software-defined framework for developing, deploying, and managing network functions,” in *ACM SIGCOMM*, 2016.
- [26] B. Anwer, T. Benson, N. Feamster, and D. Levin, “Programming slick network functions,” in *ACM SOSR ’15*, 2015.
- [27] S. Palkar, C. Lan, S. Han, K. Jang, A. Panda, S. Ratnasamy, L. Rizzo, and S. Shenker, “E2: a framework for nfv applications,” in *ACM SOSP ’15*, 2015.
- [28] W. Zhang, G. Liu, A. Mohammadkhan, J. Hwang, K. Ramakrishnan, and T. Wood, “SDNFV: Flexible and dynamic software defined control of an application-and flow-aware data plane,” in *ACM Middleware Industry ’16*, 2016.
- [29] Z. Meng, J. Bi, H. Wang, C. Sun, and H. Hu, “Micronf: An efficient framework for enabling modularized service chains in nfv,” *IEEE JSAC*, 2019.
- [30] S. R. Chowdhury, Anthony, H. Bian, T. Bai, and R. Boutaba, “ μ NF: A disaggregated packet processing architecture,” in *IEEE NetSoft*, 2019.
- [31] G. P. Katsikas, T. Barbette, D. Kostic, R. Steinert, and G. Q. Maguire Jr, “Metron: NFV Service Chains at the True Speed of the Underlying Hardware,” in *USENIX NSDI*, 2018.
- [32] C. Price, S. Rivera *et al.*, “Opnfv: An open platform to accelerate nfv,” *White Paper. A Linux Foundation Collaborative Project*, 2012.
- [33] R. Bonafiglia, S. Miano, S. Nuccio, F. Risso, and A. Sapio, “Enabling nfv services on resource-constrained cpes,” in *IEEE Cloudnet*, 2016.
- [34] Z. Xu, Y. Cui, and Y. Jiang, “Confv: An endhost-cloud collaborated network function virtualization framework,” in *IEEE IMCEC*, 2018.

- [35] J. W. Anderson, R. Braud, R. Kapoor, G. Porter, and A. Vahdat, “xomb: extensible open middleboxes with commodity servers,” in *ACM/IEEE ANCS*, 2012.
- [36] V. Sekar, N. Egi, S. Ratnasamy, M. K. Reiter, and G. Shi, “Design and implementation of a consolidated middlebox architecture,” in *USENIX NSDI*, 2012.
- [37] M. Bezahaf, A. Alim, and L. Mathy, “Flowos: A flow-based platform for middleboxes,” in *ACM HotMiddlebox '13*, 2013.
- [38] A. Panda, S. Han, K. Jang, M. Walls, S. Ratnasamy, and S. Shenker, “NetBricks: Taking the V out of NFV,” in *USENIX OSDI*, 2016.
- [39] R. Riggio, I. G. B. Yahia, S. Latré, and T. Rasheed, “Scylla: A language for virtual network functions orchestration in enterprise wlangs,” in *IEEE/IFIP NOMS*, 2016.
- [40] P. Naik, A. Kanase, T. Patel, and M. Vutukuru, “libvnf: Building virtual network functions made easy,” in *ACM SOCC*, 2018.
- [41] A. Alim, R. G. Clegg, L. Mai, L. Rupperecht, E. Seckler, P. Costa, P. Pietzuch, A. L. Wolf, N. Sultana, J. Crowcroft *et al.*, “{FLICK}: Developing and running application-specific network services,” in *USENIX ATC*, 2016.
- [42] O. Alipourfard and M. Yu, “Decoupling Algorithms and Optimizations in Network Functions,” in *ACM HotNets*, 2018.
- [43] S. Miano, M. Bertrone, F. Risso, M. V. Bernal, Y. Lu, J. Pi, and A. Shaikh, “A Service-Agnostic Software Framework for Fast and Efficient In-Kernel Network Services,” in *ACM/IEEE ANCS*, 2019.
- [44] “eBPF - extended Berkeley Packet Filter,” <https://prototype-kernel.readthedocs.io/en/latest/bpf/>, 2020.
- [45] J. Duan, X. Yi, J. Wang, C. Wu, and F. Le, “Netstar: A future/promise framework for asynchronous network functions,” *IEEE JSAC*, 2019.
- [46] M. Gallo and R. Laufer, “ClickNF: a modular stack for custom network functions,” in *USENIX ATC 18*, 2018.
- [47] E. Kohler, R. Morris, B. Chen, J. Jannotti, and M. F. Kaashoek, “The click modular router,” *ACM TOCS*, 2000.
- [48] S. Woo, J. Sherry, S. Han, S. Moon, S. Ratnasamy, and S. Shenker, “Elastic scaling of stateful network functions,” in *USENIX NSDI*, 2018.
- [49] M. Kablan, A. Alsudais, E. Keller, and F. Le, “Stateless network functions: Breaking the tight coupling of state and processing,” in *USENIX NSDI*, 2017.
- [50] J. Duan, X. Yi, S. Zhao, C. Wu, H. Cui, and F. Le, “Nfvactor: A resilient nfv system using the distributed actor model,” *IEEE JSAC*, 2019.
- [51] M. Mechtri, C. Ghribi, O. Soualah, and D. Zeglache, “Nfv orchestration framework addressing sfc challenges,” *IEEE Communications Magazine*, 2017.
- [52] D. Lopez, “Openmano: The dataplane ready open source nfv mano stack,” in *IETF Meeting Proceedings, Dallas, Texas, USA*, 2015.
- [53] “OPEN BATON: An extensible and customizable NFV MANO-compliant framework,” <https://openbaton.github.io/>, 2019.
- [54] W. Shen, M. Yoshida, K. Minato, and W. Imajuku, “vConductor: An enabler for achieving virtual network integration as a service,” *IEEE Communications Magazine*, 2015.

- [55] G. Xilouris, M.-A. Kourtis, M. J. McGrath, V. Riccobene, G. Petralia, E. Markakis, E. Palis, A. Georgios, G. Gardikis, J. F. Riera *et al.*, “T-nova: Network functions as-a-service over virtualised infrastructures,” in *IEEE NFV-SDN*, 2015.
- [56] I. Trajkovska, M.-A. Kourtis, C. Sakkas, D. Baudinot, J. Silva, P. Harsh, G. Xylouris, T. M. Bohnert, and H. Koumaras, “Sdn-based service function chaining mechanism and service prototype implementation in nfv scenario,” *Computer Standards & Interfaces*, vol. 54, pp. 247–265, 2017.
- [57] J. F. Riera, J. Batallé, J. Bonnet, M. Días, M. McGrath, G. Petralia, F. Liberati, A. Giuseppi, A. Pietrabissa, A. Ceselli *et al.*, “Tenor: Steps towards an orchestration platform for multi-pop nfv deployment,” in *IEEE NetSoft*, 2016.
- [58] B. Nogales, I. Vidal, D. R. Lopez, J. Rodriguez, J. Garcia-Reinoso, and A. Azcorra, “Design and deployment of an open management and orchestration platform for multi-site nfv experimentation,” *IEEE Communications Magazine*, vol. 57, no. 1, pp. 20–27, 2019.
- [59] S. Rajagopalan, D. Williams, H. Jamjoom, and A. Warfield, “Split/merge: System support for elastic execution in virtual middleboxes,” in *USENIX NSDI*, 2013.
- [60] Y. Wang, G. Xie, Z. Li, P. He, and K. Salamatian, “Transparent flow migration for nfv,” in *IEEE ICNP*, 2016.
- [61] A. Gember-Jacobson, R. Viswanathan, C. Prakash, R. Grandl, J. Khalid, S. Das, and A. Akella, “OpenNF: Enabling innovation in network function control,” in *ACM SIGCOMM CCR*, 2014.
- [62] B. Kothandaraman, M. Du, and P. Sköldström, “Centrally controlled distributed vnf state management,” in *ACM HotMiddlebox ’15*, 2015.
- [63] L. Liu, H. Xu, Z. Niu, P. Wang, and D. Han, “U-haul: Efficient state migration in nfv,” in *ACM APSys*, 2016.
- [64] M. Zhang, J. Bai, G. Li, Z. Meng, H. Li, H. Hu, and M. Xu, “When NFV Meets ANN: Rethinking Elastic Scaling for ANN-based NFs,” in *IEEE ICNP*, 2019.
- [65] S. Lange, H.-G. Kim, S.-Y. Jeong, H. Choi, J.-H. Yoo, and J. W.-K. Hong, “Machine learning-based prediction of vnf deployment decisions in dynamic networks,” in *IEEE APNOMS*, 2019.
- [66] J. Khalid, A. Gember-Jacobson, R. Michael, A. Abhashkumar, and A. Akella, “Paving the Way for NFV: Simplifying Middlebox Modifications Using StateAlyzr,” in *USENIX NSDI*, 2016.
- [67] J. Khalid and A. Akella, “Correctness and performance for stateful chained network functions.” in *USENIX NSDI*, 2019.
- [68] B. Tschaen, Y. Zhang, T. Benson, S. Banerjee, J. Lee, and J.-M. Kang, “Sfc-checker: Checking the correct forwarding behavior of service function chaining,” in *IEEE NFV-SDN*, 2016.
- [69] J. Sherry, P. X. Gao, S. Basu, A. Panda, A. Krishnamurthy, C. Maciocco, M. Manesh, J. Martins, S. Ratnasamy, L. Rizzo *et al.*, “Rollback-recovery for middleboxes,” in *ACM SIGCOMM CCR*, 2015.
- [70] S. G. Kulkarni, W. Zhang, J. Hwang, S. Rajagopalan, K. Ramakrishnan, T. Wood, M. Arumathurai, and X. Fu, “NFVNice: Dynamic backpressure and scheduling for nfv service chains,” in *ACM SIGCOMM ’17*, 2017.
- [71] L. Zhang, C. Li, P. Wang, Y. Liu, Y. Hu, Q. Chen, and M. Guo, “Characterizing and orchestrating nfv-ready servers for efficient edge data processing,” in *ACM IWQoS ’19*, 2019.
- [72] S. R. Chowdhury, T. Bai, R. Boutaba, J. François *et al.*, “UNiS: A user-space non-intrusive workflow-aware virtual network function scheduler,” in *IEEE CNSM*, 2018.
- [73] G. P. Katsikas, M. Enguehard, M. Kuźniar, G. Q. Maguire Jr, and D. Kostić, “SNF: synthesizing high performance NFV service chains,” *PeerJ Computer Science*, 2016.

- [74] A. Singhvi, J. Khalid, A. Akella, and S. Banerjee, “Snf: Serverless network functions,” *arXiv preprint arXiv:1910.07700*, 2019.
- [75] A. Tootoonchian, A. Panda, C. Lan, M. Walls, K. Argyraki, S. Ratnasamy, and S. Shenker, “Resq: Enabling slos in network function virtualization,” in *USENIX NSDI*, 2018.
- [76] Y. Hu, M. Song, and T. Li, “Towards full containerization in containerized network function virtualization,” *ACM SIGOPS Operating Systems Review*, 2017.
- [77] D. Cotroneo, R. Natella, and S. Rosiello, “Nfv-throttle: An overload control framework for network function virtualization,” *IEEE TNSM*, 2017.
- [78] J. Khalid, E. Rozner, W. Felter, C. Xu, K. Rajamani, A. Ferreira, and A. Akella, “Iron: Isolating Network-based CPU in Container Environments,” in *USENIX NSDI*, 2018.
- [79] L. Cao, P. Sharma, S. Fahmy, and V. Saxena, “Nfv-vital: A framework for characterizing the performance of virtual network functions,” in *IEEE NFV-SDN*, 2015.
- [80] R. V. Rosa, C. Bertoldo, and C. E. Rothenberg, “Take your vnf to the gym: A testing framework for automated nfv performance benchmarking,” *IEEE Communications Magazine*, 2017.
- [81] Q. Du, Z. Ni, R. Zhu, M. Xu, K. Guo, W. You, R. Huang, K. Yin, and Q. Zheng, “A service-based testing framework for nfv platform performance evaluation,” in *IEEE ICRMS*, 2018.
- [82] F. Moradi, C. Flinta, A. Johnsson, and C. Meirosu, “Conmon: An automated container based network performance monitoring system,” in *IFIP/IEEE IM*, 2017.
- [83] F. Rath, J. Krude, J. R uth, D. Schemmel, O. Hohlfeld, J.  . Bitsch, and K. Wehrle, “Symperf: Predicting network function performance,” in *ACM SIGCOMM Posters and Demos*, 2017.
- [84] S. Geissler, S. Lange, F. Wamser, T. Zimmer, and T. Ho feld, “KOMon - Kernel-based Online Monitoring of VNF Packet Processing Times,” in *IEEE NetSys*, 2019.
- [85] I. J. Sanz, D. M. F. Mattos, and O. C. M. B. Duarte, “Sfcp perf: An automatic performance evaluation framework for service function chaining,” in *IEEE/IFIP NOMS*, 2018.
- [86] P. Naik, D. K. Shaw, and M. Vutukuru, “Nfvperf: Online performance monitoring and bottleneck detection for nfv,” in *IEEE NFV-SDN*, 2016.
- [87] W. Wu, K. He, and A. Akella, “Perfsight: Performance diagnosis for software dataplanes,” in *ACM IMC*, 2015.
- [88] R. V. Rosa, C. E. Rothenberg, and R. Szabo, “Vbaas: Vnf benchmark-as-a-service,” in *IEEE EWSDN ’15*, 2015.
- [89] “Barometer Home, OPNFV wiki,” <https://wiki.opnfv.org/display/fastpath/Barometer+Home>.
- [90] M. Dodare, Y. Taguchi, R. Kawashima, H. Nakayama, T. Hayashi, and H. Matsuo, “NFV-VIPP: Catching Internal Figures of Packet Processing for Accelerating Development and Operations of NFV-nodes,” in *IFIP CNSM*, 2019.
- [91] R. Iyer, L. Pedrosa, A. Zaostrovnykh, S. Pirelli, K. Argyraki, and G. Candea, “Performance contracts for software network functions,” in *USENIX NSDI*, 2019.
- [92] J. Gong, Y. Li, B. Anwer, A. Shaikh, and M. Yu, “Deepdiag: Detailed nfv performance diagnosis,” in *ACM SIGCOMM 2019 Conference Posters and Demos*, 2019.
- [93] L. Pedrosa, R. Iyer, A. Zaostrovnykh, J. Fietz, and K. Argyraki, “Automated synthesis of adversarial workloads for network functions,” in *ACM SIGCOMM ’18*, 2018.
- [94] M. T. Raza, S. Lu, and M. Gerla, “vepc-sec: Securing lte network functions virtualization on public cloud,” *IEEE Transactions on Information Forensics and Security*, 2019.

- [95] H. J. Asghar, L. Melis, C. Soldani, E. De Cristofaro, M. A. Kaafar, and L. Mathy, "Splitbox: Toward efficient private network function virtualization," in *ACM HotMiddlebox '16*, 2016.
- [96] C. Lan, J. Sherry, R. A. Popa, S. Ratnasamy, and Z. Liu, "Embark: Securely outsourcing middleboxes to the cloud," in *USENIX NSDI*, 2016.
- [97] G. A. F. Rebello, I. D. Alvarenga, I. J. Sanz, and O. C. M. Duarte, "Bsec-nfvo: A blockchain-based security for network function virtualization orchestration," in *IEEE ICC*, 2019.
- [98] F. McKeen, I. Alexandrovich, A. Berenzon, C. V. Rozas, H. Shafi, V. Shanbhogue, and U. R. Savaonkar, "Innovative instructions and software model for isolated execution." *Hasp@ isca*, 2013.
- [99] M.-W. Shih, M. Kumar, T. Kim, and A. Gavrilovska, "S-nfv: Securing nfv states by using sgx," in *ACM SDN-NFV Security '16*, 2016.
- [100] M. Coughlin, E. Keller, and E. Wustrow, "Trusted click: overcoming security issues of NFV in the cloud," in *ACM SDN-NFV Sec'17*, 2017.
- [101] B. Trach, A. Krohmer, F. Gregor, S. Arnautov, P. Bhatotia, and C. Fetzer, "ShieldBox: Secure middleboxes using shielded execution," in *ACM SOSR*, 2018.
- [102] E. Marku, G. Biczók, and C. Boyd, "Towards protected vnfs for multi-operator service delivery," in *IEEE NetSoft*, 2019.
- [103] R. Poddar, C. Lan, R. A. Popa, and S. Ratnasamy, "Safebricks: Shielding network functions in the cloud," in *USENIX NSDI*, 2018.
- [104] H. Duan, C. Wang, X. Yuan, Y. Zhou, Q. Wang, and K. Ren, "Lightbox: Full-stack protected stateful middlebox at lightning speed," in *ACM SIGSAC CCS*, 2019.
- [105] J. Hwang, K. K. Ramakrishnan, and T. Wood, "Netvm: High performance and flexible networking using virtualization on commodity platforms," *IEEE TNSM*, 2015.
- [106] W. Zhang, G. Liu, W. Zhang, N. Shah, P. Lopreiato, G. Todeschi, K. Ramakrishnan, and T. Wood, "Opennetvm: A platform for high performance network service chains," in *ACM HotMiddlebox'16*, 2016.
- [107] A. Dhakal and K. Ramakrishnan, "NetML: An NFV Platform with Efficient Support for Machine Learning Applications," in *IEEE NetSoft*, 2019.
- [108] K. Yasukata, F. Huici, V. Maffione, G. Lettieri, and M. Honda, "HyperNF: Building a high performance, high utilization and fair NFV platform," in *ACM SOCC*, 2017.
- [109] M. Gallo, S. Ghamri-Doudane, and F. Pianese, "Climbos: A modular nfv cloud backend for the internet of things," in *IFIP NTMS*, 2018.
- [110] C. Zheng, Q. Lu, J. Li, Q. Liu, and B. Fang, "A flexible and efficient container-based nfv platform for middlebox networking," in *ACM SAC*, 2018.
- [111] "NFF-Go -Network Function Framework for GO (former YANFF)," <https://github.com/intel-go/nff-go>, 2019.
- [112] W. Zhang, J. Hwang, S. Rajagopalan, K. Ramakrishnan, and T. Wood, "Flurries: Countless fine-grained nfs for flexible per-flow customization," in *ACM CoNEXT*, 2016.
- [113] G. Liu, Y. Ren, M. Yurchenko, K. Ramakrishnan, and T. Wood, "Microboxes: high performance nfv with customizable, asynchronous tcp stacks and dynamic subscriptions," in *ACM SIGCOMM '18*, 2018.
- [114] Y. Hu and T. Li, "Enabling efficient network service function chain deployment on heterogeneous server platform," in *IEEE HPCA*, 2018.

- [115] Y. Jiang, Y. Cui, W. Wu, Z. Xu, J. Gu, K. Ramakrishnan, Y. He, and X. Qian, “Speedybox: Low-latency nfv service chains with cross-nf runtime consolidation,” in *IEEE ICDCS*, 2019.
- [116] Y. Zhang, B. Anwer, V. Gopalakrishnan, B. Han, J. Reich, A. Shaikh, and Z.-L. Zhang, “Parabox: Exploiting parallelism for virtual network functions in service chaining,” in *ACM SOSR*, 2017.
- [117] C. Sun, J. Bi, Z. Zheng, H. Yu, and H. Hu, “NFP: Enabling network function parallelism in NFV,” in *ACM SIGCOMM ’17*, 2017.
- [118] P. Zave, R. A. Ferreira, X. K. Zou, M. Morimoto, and J. Rexford, “Dynamic service chaining with dysco,” in *ACM SIGCOMM*, 2017.
- [119] T. Barbette, C. Soldani, R. Gaillard, and L. Mathy, “Building a chain of high-speed vnfs in no time,” in *IEEE HPSR*, 2018.
- [120] Z. Shen and Y. Zhang, “An NFV Framework for Supporting Elastic Scaling of Service Function Chain,” in *IEEE ICC*, 2018.
- [121] G. P. Katsikas, G. Q. Maguire Jr, and D. Kostić, “Profiling and accelerating commodity nfv service chains with scc,” *Journal of Systems and Software*, 2017.
- [122] Y. Taguchi, R. Kawashima, H. Nakayama, T. Hayashi, and H. Matsuo, “Fast datapath processing based on hop-by-hop packet aggregation for service function chaining,” *IEICE TRANSACTIONS on Information and Systems*, vol. 102, no. 11, pp. 2184–2194, 2019.
- [123] L. M. M. Zorello, M. G. T. Vieira, R. A. G. Tejos, M. A. T. Rojas, C. Meirosu, and T. C. M. de Brito Carvalho, “Improving energy efficiency in nfv clouds with machine learning,” in *2018 IEEE 11th International Conference on Cloud Computing (CLOUD)*. IEEE, 2018, pp. 710–717.
- [124] Y. Yuan, Y. Wang, R. Wang, and J. Huang, “Halo: accelerating flow classification for scalable packet processing in nfv,” in *Proceedings of the 46th International Symposium on Computer Architecture*, 2019, pp. 601–614.
- [125] X. Chen, D. Zhang, X. Wang, K. Zhu, and H. Zhou, “P4SC: Towards High-Performance Service Function Chain Implementation on the P4-Capable Device,” in *IFIP/IEEE IM*, 2019.
- [126] M. He, A. Basta, A. Blenk, N. Deric, and W. Kellerer, “P4nfv: An nfv architecture with flexible data plane reconfiguration,” in *IEEE CNSM*, 2018.
- [127] X. Ge, Y. Liu, D. H. Du, L. Zhang, H. Guan, J. Chen, Y. Zhao, and X. Hu, “Openanfv: Accelerating network function virtualization with a consolidated framework in openstack,” in *ACM SIGCOMM CCR*, 2014.
- [128] Y. Le, H. Chang, S. Mukherjee, L. Wang, A. Akella, M. M. Swift, and T. Lakshman, “Uno: unifying host and smart nic offload for flexible packet processing,” in *ACM SoCC ’17*, 2017.
- [129] H. Eran, L. Zeno, M. Tork, G. Malka, and M. Silberstein, “NICA: An Infrastructure for Inline Acceleration of Network Applications,” in *USENIX ATC*, 2019.
- [130] X. Yi, J. Wang, J. Duan, W. Bai, C. Wu, Y. Xiong, and D. Han, “Flowshader: a generalized framework for gpu-accelerated vnf flow processing,” in *IEEE ICNP*, 2019.
- [131] X. Yi, J. Duan, and C. Wu, “Gpunfv: a gpu-accelerated nfv system,” in *ACM APNet’17*, 2017.
- [132] Z. Zheng, J. Bi, C. Sun, H. Yu, H. Hu, Z. Meng, S. Wang, K. Gao, and J. Wu, “Gen: A gpu-accelerated elastic framework for nfv,” in *ACM APNet ’18*, 2018.
- [133] Z. Zheng, J. Bi, H. Wang, C. Sun, H. Yu, H. Hu, K. Gao, and J. Wu, “Grus: Enabling latency slos for gpu-accelerated nfv systems,” in *IEEE ICNP*, 2018.

- [134] K. Zhang, B. He, J. Hu, Z. Wang, B. Hua, J. Meng, and L. Yang, “G-NET: Effective GPU Sharing in NFV Systems,” in *USENIX NSDI*, 2018.
- [135] P. Zheng, A. Narayanan, and Z.-L. Zhang, “A closer look at nvf execution models,” in *Proceedings of the 3rd Asia-Pacific Workshop on Networking 2019*, 2019, pp. 85–91.
- [136] E. Jeong, S. Wood, M. Jamshed, H. Jeong, S. Ihm, D. Han, and K. Park, “mTCP: a Highly Scalable User-level TCP Stack for Multicore Systems,” in *USENIX NSDI*, 2014.
- [137] T. Zhang, L. Linguaglossa, M. Gallo, P. Giaccone, L. Iannone, and J. Roberts, “Comparing the performance of state-of-the-art software switches for nvf,” in *ACM CoNEXT*, 2019.
- [138] S. Han, K. Jang, A. Panda, S. Palkar, D. Han, and S. Ratnasamy, “Softnic: A software nic to augment hardware,” *Tech. Rep. UCB/EECS-2015-155*, 2015.
- [139] L. Rizzo and G. Lettieri, “Vale, a switched ethernet for virtual machines,” in *ACM CoNEXT*, 2012.
- [140] T. Barbette, C. Soldani, and L. Mathy, “Fast userspace packet processing,” in *ACM/IEEE ANCS*, 2015.
- [141] B. Pfaff, J. Pettit, T. Koponen, E. Jackson, A. Zhou, J. Rajahalme, J. Gross, A. Wang, J. Stringer, P. Shelar *et al.*, “The design and implementation of open vswitch,” in *USENIX NSDI*, 2015.
- [142] “Open vSwitch with DPDK,” <http://docs.openvswitch.org/en/latest/intro/install/dpdk/>, 2020.
- [143] “Data Plane Development Kit,” <https://www.dpdk.org/>, 2020.
- [144] L. Rizzo, “Netmap: a novel framework for fast packet i/o,” in *USENIX Security 12*, 2012.
- [145] “Linux user space library for network socket acceleration based on RDMA compatible network adapters,” <https://github.com/Mellanox/libvma>, 2019.
- [146] L. Linguaglossa, S. Lange, S. Pontarelli, G. Rétvári, D. Rossi, T. Zinner, R. Bifulco, M. Jarschel, and G. Bianchi, “Survey of performance acceleration techniques for network function virtualization,” *Proceedings of the IEEE*, 2019.