

DFSSD: Deep Faults and Shallow State Duality, A Provably Strong Obfuscation Solution for Circuits with Restricted Access to Scan Chain

Shervin Roshanisefat*, Hadi Mardani Kamali*, Kimia Zamiri Azar*, Sai Manoj Pudukotai Dinakarrao*,
Naghmeh Karimi[†], Houman Homayoun[†], Avesta Sasan*

*Department of ECE, George Mason University, e-mail: {sroshani, hmdardani, kzamiria, spudukot, asasan}@gmu.edu

[†]Department of CSEE, University of Maryland, Baltimore County, e-mail: nkarimi@umbc.edu

[†]Department of ECE, University of California, Davis, e-mail: hhomayoun@ucdavis.edu

Abstract—In this paper, we introduce DFSSD, a novel logic locking solution for sequential and FSM circuits with a restricted (locked) access to the scan chain. DFSSD combines two techniques for obfuscation: (1) **Deep Faults**, and (2) **Shallow State Duality**. Both techniques are specifically designed to resist against sequential SAT attacks based on bounded model checking. The shallow state duality prevents a sequential SAT attack from taking a shortcut for early termination without running an exhaustive unbounded model checker to assess if the attack could be terminated. The deep fault, on the other hand, provides a designer with a technique for building deep, yet key recoverable faults that could not be discovered by sequential SAT (and bounded model checker based) attacks in a reasonable time.

I. INTRODUCTION

To reduce the cost of semiconductor fabrication and shorten the time to market of integrated circuits (IC), most of the fabrication processes are pushed offshore [1]. This globalization of supply chain has tremendously raised security concerns such as the possibility of third-party intellectual property (3PIP) theft, IC overproduction, Trojan insertion, and adversarial reverse engineering. To overcome such threats, various active and passive *design-for-trust* mechanisms have been proposed in the literature, among which logic locking, *a.k.a.* hardware obfuscation, has been manifested as proactive protection against all these threats [2, 3]. The validity and strength of the state-of-the-art logic locking solutions to protect IPs/ICs against adversaries in the manufacturing supply chain was seriously challenged in recent years after the introduction of the Boolean satisfiability attack (SAT Attack) [4–6]. After introduction of the SAT attacks, researchers investigated a body of locking solutions with the objective of resisting the SAT attack [7–12]. However, further research revealed that increasing resistance against SAT attack makes such solutions vulnerable against alternative (and even simpler) attack solutions such as Signal Probability Skew (SPS) and structural analysis-based attacks [13–15].

The original SAT attack was only applicable to combinational circuits. However, the existence of the scan chain, allows an adversary to treat the FSM and sequential circuits as a combinational circuit; using the scan chain, the attacker to load desired input into scan registers, carry the attack for one cycle, and readout the output through the scan chain [4]. Hence, to prevent the SAT attack on obfuscated sequential and FSM solutions, various means for restricting access to the scan chain [16, 17] was investigated. In this approach, which is illustrated in Fig. 1, an obfuscation solution is constructed using two key values: (1) a key for obfuscating the functional logic, and (2) a key for obfuscating the scan chain.

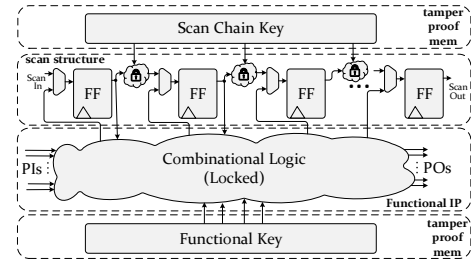

Fig. 1. An obfuscated IC with restricted access to scan chain.

Restricting access to (or locking of) the scan chain, however, did not stop the researchers from developing variants of SAT attack solution capable of attacking an obfuscated circuit. Lack of access to the scan chain was addressed in [18] by changing the attack model to find a sequence of inputs (rather than a single input) resulting in incorrect output. This attack, so-called unrolling-based SAT (UB-SAT) attack, expands the given FSM in time to be able to find a sequence of distinguishing inputs.

To defend against UB-SAT and model checker based attacks in design with restricted access to the scan chain, in this paper, we introduce a new obfuscation solution denoted as Deep Faults and Shallow State Duality (DFSSD). The DFSSD obfuscation scheme exploits the weaknesses of the existing attacks in obfuscating FSM and sequential circuits and prevents these attacks from satisfying their early exit conditions, forcing them to become unbounded. To build the DFSSD solution, we propose a combination of two concepts: (1) encrypting **Deep Faults (DF)**, the discovery of which requires specific traversal patterns with a large enough depth that cannot be reached by bounded model checkers or unrolling based SAT attacks. (2) encoding **Shallow State Duality (SSD)**, in which by implementing key-controlled duplicate states, the early termination conditions of the UB-SAT are violated.

II. PRELIMINARY BACKGROUND

As described earlier, limiting access to the scan chain removes the ability of the attacker to deploy a pure SAT attack on the combinational logic between internal scan registers, and has to revert to the weaker variant of SAT attacks such as UB-SAT (working with only primary input and primary output). Following is a short background on Scan chain obfuscation and proposed attack solutions for de-obfuscating such solutions needed for understanding the DFSSD.

Securing Scan Chain Structure: Several methods have been recently proposed in the literature to obfuscate the scan chains [19, 20]. To secure the test and debug operations,

Algorithm 1 Sequential Attack on Obfuscated Circuits

```
1:  $b = \text{initial\_boundary}$ ,  $\text{Terminated} = \text{False}$ ;  
2:  $\text{Model} = C(X, K_1, Y_1) \wedge C(X, K_2, Y_2) \wedge (Y_1 \neq Y_2)$ ;  
3: while not  $\text{Terminated}$  do  
4:   while  $(X_{DIS}, K_1, K_2) \leftarrow \text{BMC}(\text{Model}, b) = T$  do  
5:      $Y_f \leftarrow C_{\text{BlackBox}}(X_{DI})$ ;  
6:      $\text{Model} = \wedge C(X_{DIS}, K_1, Y_f) \wedge C(X_{DIS}, K_2, Y_f)$ ;  
7:   if  $\text{UC}(\text{Model}, b) \vee \text{CE}(\text{Model}, b) \vee \text{UMC}(\text{Model})$  then  
8:      $\text{Terminated}$ ;  
9:    $b = b + \text{boundary\_step}$ ;
```

[16] proposed a design-for-security (DFS) flow that deploys a structure, denoted as *Secure Cell* (SC). However, SC was compromised via the *shift-and-leak* attack [17]. Another early attempt in this domain was the *Encrypt Flip-Flop* (EFF) [19] scheme. In EFF the output of each scan flop is obfuscated based on a key value such that either the Q or Q_{bar} output is propagated in the scan chain, and accordingly, the *scan-in* sequence is also modified. The EFF was also tackled by the *ScanSAT* attack [21]. The *Dynamically Obfuscated Scan* (DOS) [20] scheme obfuscates the scan chain while periodically changing the obfuscation key during the test process. Assuming a hard to break scan chain obfuscation, the pure SAT attack could be no longer applied. Hence, an attacker should resort to SAT attack variants designed for attacking scan-access restricted obfuscation solutions by only relying on controllability (observability) of primary inputs (outputs).

Deobfuscation Methods Without Scan Chain Access: El Massad et al. [18] extended the SAT attack to circuits with no scan chain access, proposing an attack that only required access to the primary input/outputs of an activated chip. The attack procedure is shown in Algorithm 1. Similar to the SAT attack, it has an iterative process for pruning the search space. However, due to the restricted access to the internal registers, rather than finding a Discriminating Input (in each iteration), it finds a sequence of inputs X denoted as *Discriminating Input Sequence* (X_{DIS}) that can generate two different outputs for the same input sequence for two different keys. In this algorithm, $C(X, K, Y)$ refers to the obfuscated circuit producing output sequence Y using input sequence X and key vector K , and $C_{\text{BlackBox}}(X)$ refers to the output sequence of the activated circuit for the same input sequence. After transforming the obfuscated circuit to a circuit SAT (Model) problem, the attack instantiates a Bounded Model Checker (BMC) to find the X_{DIS} . After the discovery of each X_{DIS} , the Model is updated with a new condition to make sure that the next onset of keys, that will be discovered in the subsequent attack iterations, produce the same output for previously discovered X_{DIS} . This process continues until no further X_{DIS} is found within the boundary of b .

After reaching the boundary, the algorithm checks three criteria to determine if the attack can be terminated: (1) **Unique Completion (UC):** This criterion checks for the uniqueness of the key. If there is only a single key that satisfying all previous DIS es, the attack is terminated. (2) **Combinational Equivalence (CE):** If there is more than one key that agrees with all previously found X_{DIS} , the attack checks the combinational equivalency of the remaining keys. In this step, the input/output of FFs are considered as pseudo primary outputs/inputs allowing the attacker to treat the circuit as combinational. The resulting circuit is subjected to a SAT attack, and if the SAT solver fails to

find a different output or next state for two different keys, it concludes that all remaining keys are correct and the attack terminates. (3) **Unbounded Model Check (UMC):** If UC and CE fail, the attack checks the existence of a DIS for the remaining keys using an unbounded model checker. This is an exhaustive search with no limitation on bound (or the number of unrolls). If no DIS is discovered, the existing set of DIS is a complete set, and the attack terminates. Otherwise, the bound is increased and previous steps are repeated. The original implementation of this attack [18] uses NuSMV as the model checker and is not scalable for larger circuits. Shamsi et al. improved this attack via implementing several tweaks in the attack procedure [22].

III. PROPOSED METHODS

The practicality of UB-SAT attack (proposed in [18]) is grounded on the use of a fast bounded model checker (BMC) [23] and the implementation of early termination strategies to avoid the exhaustive search. This allows the attacker to avoid using time-consuming and exhaustive unbounded model checking runs for the discovery of DISes and to find the obfuscation key in a reasonable time. In this section, we describe an obfuscation solution that 1) prevent the UC and CE early termination, and 2) pushes the required bound for a BMC solver to an unreasonably large bound (which is defined at design time), resulting in unreasonable attack time against the proposed obfuscation solution.

A. Shallow State Duality

The first termination criterion (UC) relies on the uniqueness of the key and it fails if there is more than one valid key for the obfuscated circuit. In the sequential attack proposed in [18], UC was the main termination criterion for most of the benchmarks. For the second termination criteria (CE), successful termination relies on the equality of all next state and output values for remaining candidate keys for all input and state combinations.

Our proposed solution for breaking both UC and CE termination checks is simply adding duplicate key controlled, yet valid states such that more than one valid key exists. We refer to this scheme as Shallow State Duality (SSD). This concept is illustrated in Fig. 2. In this example, the original FSM has five Reachable States (RS) and three Un-Reachable States (URS). In the modified FSM, the unreachable states are used to replicate three of the existing states such that the transition to the original or replicated state is controlled by a key. In this example, all the replicated states produce the same outputs as the original state and key bits are correct for both values of 0 and 1, although, it might not be the case in a different implementation. Therefore, the UC check fails as more than one correct key exists. In addition, in the CE check, the input to the registers is considered as a primary output. Hence, for duplicated states, two different key values do not generate the same output as they do not reach the same state. Note that the SSD is not a form of obfuscation as multiple keys are correct keys and it should be combined with our obfuscation solution which is described next. However, it is an effective and low-overhead technique to prevent early termination of the UB-SAT attack and its variants.

The duplicate states can be added during the state encoding (design time) or after logic synthesis (physical design time).

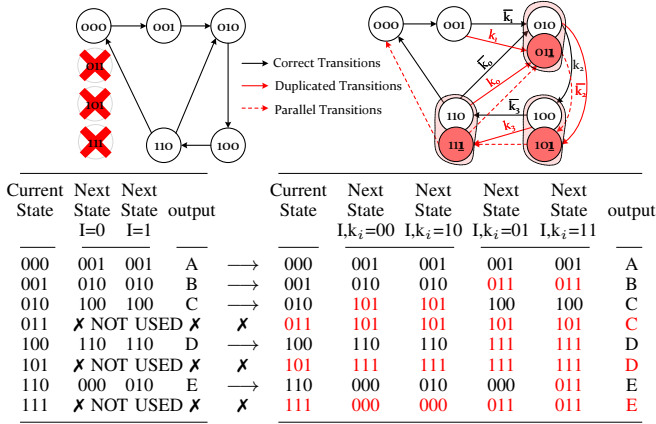

Fig. 2. (a) Original state transition graph, (b) Modified state transition graph with duplicate states (shallow state duality).

Algorithm 2 Extracting an unreachable state with minimum hamming distance from a reachable state

```

1: boundary = limit, i = 1, hd = 1
2: Model = Ccomb(X, S, O, Snext) ∧ Ccomb(X1, Sinit, O1, S1)
3: while true do
4:   A = (∀(S, X), ∃Surs, Snext ≠ Surs) ∧ (HD(Surs, Si) == hd)
5:   if (Si-1, Si, Surs) ← QBF(Model ∧ A) = T then
6:     return Si-1, Si, Surs
7:   else if i < boundary then
8:     i = i + 1
9:     Model = ∧ Ccomb(Xi, Si-1, Oi, Si)
10:  else if i == boundary and hd < output_width then
11:    i = 1, hd = hd + 1

```

Fig. 2 shows an example of a state transition graph encoded with duplicated states at design time. The circuit functionality remains unchanged while the circuit has $2^4 = 16$ correct keys.

For adding duplicate states to a synthesizer netlist, we first need to find a few unreachable states (S_{urs}). The Algorithm 2 describes our approach for finding such states using a quantified Boolean formula (QBF) solver. To minimize the logic (overhead) needed for encoding the duplicate states, we search for S_{urs} with minimum hamming distance (HD) from one of reachable (existing) states. In this Algorithm, inputs, states, outputs, and next states are defined as X , S , O , and S_{next} , respectively, and C_{comb} refers to the combinational representation of the original circuit in which the input/output of FFs are considered as pseudo primary outputs/inputs (similar to CE check in UB-SAT attack).

After initializing the boundary limit and defining the desired hamming distance (e.g. $hd=1$), a model consisting of two C_{comb} instances is created. To find a S_{urs} , one instance of C_{comb} is used as $C_{comb}(X, S, O, S_{next})$ with *for-all* condition on its primary inputs (X) and current states (S) to generate all the outputs (O) and next states (S_{next}) that could be produced by the C_{comb} . By assuming $S_{next} \neq S_{urs}$, the QBF solver will attempt to find a set of values for S_{urs} that is not a part of the generated S_{next} . Then, to select a URS from the set of S_{urs} that has a hamming distance of hd from a RS, another instance of C_{comb} as $C_{comb}(X_1, S_{init}, O_1, S_1)$ is used. In the QBF solver, this instance produces RSEs (S_1) that are reachable from the initial state (S_{init}). Any URS in S_{urs} with HD of one from the S_1 could be considered as the answer. If such a URS was not found, a new copy of C_{comb} as $C_{comb}(X_2, S_1, O_2, S_2)$ is added to the model to produce RSEs that are reachable from the initial state in two cycles. If necessary, this unrolling continues until the boundary limit to

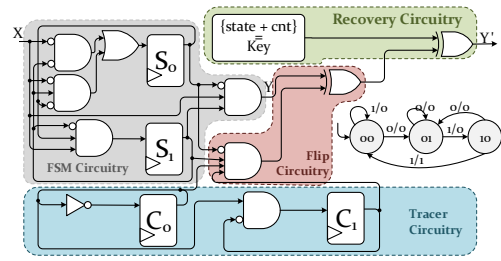

Fig. 3. Implementation of Deep Fault (DF) obfuscation for a 011 detector. The protected pattern include the counter (C_1C_0) FFs, and the (S_1S_0) state FFs. The state transition graph of the circuit is shown in the middle right.

check S_{urs} with all RSEs reachable in i cycles. When a URS is found, it is added to the netlist by adding the logic to make the transition between the URS and the original states based on the key value. The URS will produce the same output as the original RS it was duplicated from and will transition to the same next state(s) (or the duplicate of the next states).

B. Deep Faults

The sequential attack [18] relies on a bounded search space for finding a discriminating input sequence X_{DIS} , and it keeps increasing the boundary if the termination checks fail. The X_{DIS} is a sequence of inputs, each forces a transition to a new state until a discriminating state is reached, where a discriminating state refers to a state whose output is different for the same input with two different keys (a DIP condition). This state traversal (based on X_{DIS}) will not include any other discriminating state transition or repeated state. Such a discriminating state could only be found if the shortest state traversal path from the initial state to that state is shallower than the boundary condition (the number of transitions) specified when invoking the BMC solver.

The traversal depth of a sequential/FSM circuit is defined as the maximum number of state traversals (starting from initial state) where no state is visited twice. However, the sequential/FSM circuits may have a limited traversal depth [24]. This makes a BMC a plausible attack for finding all possible DIS in such circuits, as all states can be visited within a reasonably small bound. Our solution to protect against BMC formulated attack (e.g., [18]) is to increase the traversal depth of the FSM/sequential circuits and push the impact of wrong keys into deep states beyond reach of the BMC (with reasonable bound). This makes the discovery of such DIS unreasonably time consuming. We refer to such faults as deep faults.

Our obfuscation methodology for creating Deep Faults (DF) is described via the example shown in Fig. 3. The circuit targeted for obfuscation is a simple '0-1-1' input sequence detector. As illustrated, the DF is implemented by adding 1) a tracer circuit, 2) a flip circuit, and 3) a recovery circuit to the original circuit. The tracer, as described earlier, is a function-modified counter or a LSFR that changes its state each time a triggering event is observed. The triggering events can be selected state transitions, state visits, or simply the rising edge of the clock. For simplicity, in Fig. 4, the triggering event is the clock and the tracer is a 2-bit counter. The flip circuit toggles the value of a single primary output of the original circuit when a protected pattern is observed. The protected pattern is a predefined pattern generated by combining selected state registers (from the original design)

TABLE I

TRUTH TABLE FOR THE 011 DETECTOR OBFUSCATED USING A TWO-BIT COUNTER. S_1S_2 AND C_1C_2 DENOTE THE STATE AND COUNTER FFs RESPECTIVELY. Y IS THE ORIGINAL CIRCUIT OUTPUT AND K_n IS THE OUTPUT FOR EACH FOUR-BIT KEY. THE PROTECTED PATTERN AND KEY ARE 1011. STATE VALUES OF 11XX ARE UNREACHABLE.

$S_1S_2C_1C_2 Y K_0$	K_1	K_2	K_3	K_4	K_5	K_6	K_7	K_8	K_9	K_{10}	K_{11}	K_{12}	K_{13}	K_{14}	K_{15}
0000	✓	✓	✓	✓	✓	✓	✓	✓	✓	✓	✓	✓	✓	✓	✓
0001	✓	✓	✓	✓	✓	✓	✓	✓	✓	✓	✓	✓	✓	✓	✓
0010	✓	✓	✓	✓	✓	✓	✓	✓	✓	✓	✓	✓	✓	✓	✓
0011	✓	✓	✓	✓	✓	✓	✓	✓	✓	✓	✓	✓	✓	✓	✓
0100	✓	✓	✓	✓	✓	✓	✓	✓	✓	✓	✓	✓	✓	✓	✓
0101	✓	✓	✓	✓	✓	✓	✓	✓	✓	✓	✓	✓	✓	✓	✓
0110	✓	✓	✓	✓	✓	✓	✓	✓	✓	✓	✓	✓	✓	✓	✓
0111	✓	✓	✓	✓	✓	✓	✓	✓	✓	✓	✓	✓	✓	✓	✓
1000	✓	✓	✓	✓	✓	✓	✓	✓	✓	✓	✓	✓	✓	✓	✓
1001	✓	✓	✓	✓	✓	✓	✓	✓	✓	✓	✓	✓	✓	✓	✓
1010	✓	✓	✓	✓	✓	✓	✓	✓	✓	✓	✓	✓	✓	✓	✓
1011	✓	✓	✓	✓	✓	✓	✓	✓	✓	✓	✓	✓	✓	✓	✓
11xx	✗	✗	✗	✗	✗	✗	✗	✗	✗	✗	✗	✗	✗	✗	✗

S=11 is unreachable

and tracer's state register. In Fig. 3, the flip circuit is shown as a four-input AND gate that fires when the protected '10,11' pattern for ' S_1S_0, C_1C_0 ' is observed. The last component of the Deep Fault obfuscation is the recovery circuit that toggles the output signal when the inserted obfuscation key agrees with the protected pattern. Hence, when the correct key is applied (1011 in this case), the previously flipped output related to the protected pattern will flip back (recovered) by the recovery circuit, however, insertion of a wrong key will result in flipping a correct output.

Table I shows the truth table of the circuit in Fig. 3 for all key-combinations. In this circuit, when the DF is subjected to UB-SAT attack, each input can only rule out a single wrong key. Thereby, the pruning power of each discovered DIS is very limited, and the correct key is found only when the protected input is tested. This concept is similar to obfuscation solutions using point functions (e.g. SARLock [25] and Anti-SAT [26]). However, there is a fundamental difference. In point functions, the adversary uses a random input, and although the average case or worse case attack time is an exponential function of the key size, the attacker can potentially discover the correct key with a single lucky attempt. However, in deep faults, the discovery of DISes is conditioned on the tracer state, which cannot be directly controlled by input. Hence, it can guarantee a minimum bound on the number of required DISes before the discovery of the fault, which is at least equal to the number of cycles needed for the tracer to reach the fault generation state. This is a necessary condition for the generation of the fault, but it is not enough. For the fault to occur, the selection of state registers of the circuit that are included as a part of a protected pattern should also reach the fault generating pattern. Hence, the number of required DISes, which is equal to the number of cycles to reach the protected pattern, can be far larger.

The lower bound for finding the protected pattern could be defined based on the tracer event counting mechanism. For simplicity, let's assume a counter is used as the tracer circuit.

Lemma 1. *The bound requirement for a BMC solver to find the protected pattern of a deep fault which is implemented using a simple clocked counter is $C = 2^w$ where w is width of the counter.*

Proof. The protected pattern consists of two parts: 1) w bits of tracer (counter) register bits, and s bits of state registers. As illustrated in Fig. 4, the portion of protected pattern implemented by counter is reached every $C = 2^w$ cycles. However, the state transition does not have a predefined

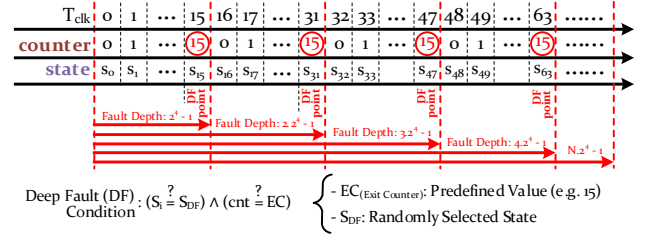

Fig. 4. Deep faults mechanism for an always-on counter.

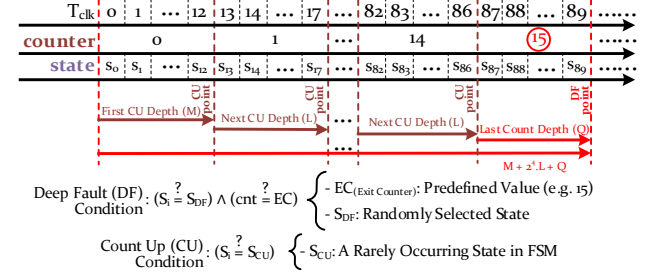

Fig. 5. Deep faults mechanism for transition-triggered counter.

traversal order, and the fault is only generated when the protected pattern (state-tracer) is observed. If the s bits of state registers, that are selected for inclusion in the protected pattern, do not take the needed value to build the protected pattern at cycle C , the fault is not generated. The next viable cycle for reaching the protected pattern will be at $2 \times C$ or in general at $N \times C$. Hence, the minimum bound requirement for a BMC attack to discover the fault is $C = 2^w$. ■

Lemma 2. *The bound requirement for a BMC solver to find the protected pattern for a deep fault which is implemented using a tracer that counts a selected state transition is $M + C \times L + Q$, where M is the shortest path to reach the selected state transition from the initial state, $C = 2^w$, w is width of the counter, L is the shortest sequence of state transitions to visit the selected triggering transition twice (shortest cycle including the triggering transition), and Q is the number of state transitions to reach a state whose encoding completes the protected pattern signature.*

Proof. As shown in Fig. 5, the tracer only counts up if a specified state transition occurs. It takes at least M cycles for the first triggering event to occur. After this transition, the shortest sequence of transition that could result in a count-up is L , where the state transition is repeated. The number of times the triggering state transition should be visited is $C = 2^w$ times. After $M + (C \times L)$ cycles, the tracer portion of the protected pattern is ready for fault generation. However, we still need another Q cycles to reach a state whose encoding completes the protected pattern. If the target state could not be met in $M + (C \times L) + Q$ cycles, it might need to repeat $(C * L)$ for N times to be able to reach the target state. So the number needed cycles for generating the deep fault is $M + N(C \times L) + Q$. The lower bound of required cycles (equal to the number of DIS) occurs at $N = 1$, thus the minimum required BMC bound for the discovery of fault is $M + (C \times L) + Q$. ■

Fig. 6 shows the result of the UB-SAT attack on the 011 detector of Fig. 3. With a 2-bit counter, according to Lemma 1, the BMC min-bound of discovering faults is $2^2 = 4$. As

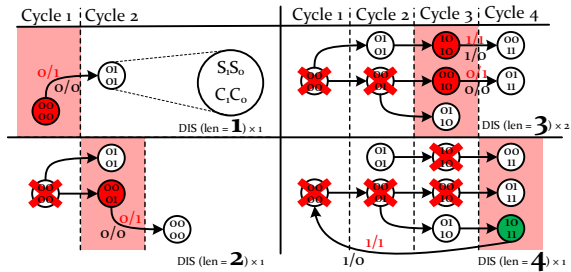

Fig. 6. Cycle by cycle DIS discovery for the 011 detector of Fig. 3, which is obfuscated using DF with a 2-bit counter. The deep fault is discovered when the deep state representing the protected state (shown in green) is reached.

expected, in each cycle at least one fault is discovered, while the deep fault is discovered at the expected boundary of 4.

C. Preventing the Removal of the Tracer

A simple mechanism to implement the DF-tracer is using a counter. However, counters can be easily identified by structural analysis [27] as they have well-defined structure and are loosely connected to the rest of the circuit. Note that, for implementing the DF, the exact counter behavior is not needed; We only need a tracer circuit for tracking cycles or events. Hence, we can use an event tracking LFSR (i.e. where LFSR state is updated based on a state transition) or a function-modified (with different encoding) counter to implement the tracer. The repetition period of LFSR (number of non-repeated LFSR state values) would serve as the depth that the fault could be delayed. In addition, to prevent the attacker from structural analysis using asynchronous signals, the enable/rest signal of the tracer circuit should not be separated from the rest of the circuit. Furthermore, the tracer could be designed to exhibit a pseudo-counter behaviour such that the update of the tracer's different register state values relies on both the existing tracer register values and other registers selected from the sequential circuit or FSM.

With the changes discussed earlier, the inserted tracer (modified-counter or LFSR) can not be functionally identified. However, it is still prone to detection by structural analysis of the data flow graph. As Fig. 7.(a) shows, the tracer is still loosely connected to the rest of circuit. To resolve this issue, the data flow graph of the obfuscated circuit should be modified such that tracer circuit can not be easily isolated. In other words, the tracer's registers' values should be also in the input logic cone of the other FFs. However, this should not affect the functionality of the tracer. One solution for modifying the data flow graph, as illustrated in Fig. 7.(b) is through the usage of Covert Gates [28]. These gates have dummy inputs, connected to always on or always off transistors, that don't affect the gates' function. In practice, the gates in the logic cone of the state registers can be replaced by Covert gates, and the tracer registers' output can be connected to the dummy inputs of the covert gates. With this change, without modifying the circuit functionality, the tracer circuit will be strongly connected to the rest of the circuit when the data flow graph is extracted. The covert gates can be also used to bring additional dummy inputs from the state machine or sequential circuit to tracer without affecting its functionality. The problem with this method is that it can only protect the design against adversaries attempting to fully reverse engineer an existing ASIC, and it does not protect the IP against an untrusted manufacturing facility. In fact, the

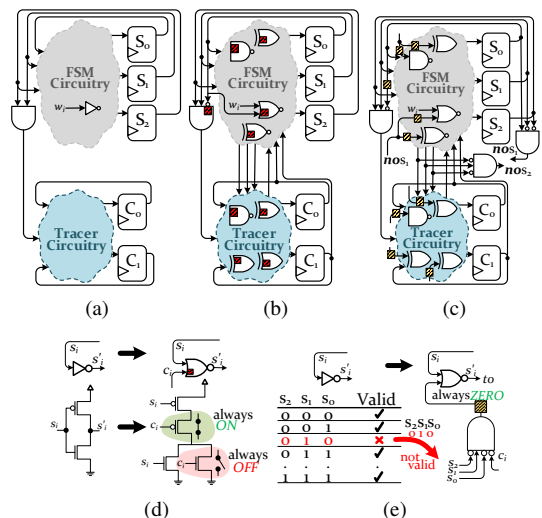

Fig. 7. Camouflaged (Covert) gates and non-occurring states could be used for merging the two strongly-connected graphs of state and counter FFs. a) DF circuit, b) DF circuit hidden by covert gates, c) DF circuit hidden by building dummy logic from non-occurring signal combinations, d) a covert gate implementation with dummy input, e) non-occurring signal used for implementing dummy logic.

manufacturing facility has access to the layout represented via the GDSII file. Hence, the Covert gates are not hidden from the foundry.

To protect against adversarial reverse engineering at untrusted foundries, one can also utilize non-occurring signal combinations in the netlist for building dummy connections to/from the tracer circuit. As Fig. 7 shows, the non-occurring signal combinations can be found using a QBF solver [9] and utilized to design an always-zero (or one) signal combined from counter FFs and signals in input cone of other state FFs.

IV. EXPERIMENTAL RESULTS

We have implemented the UB-SAT attack using Yices SMT solver by creating the combinational equivalent circuit and unrolling it for finding DISes and checking UC and CE terminations. For UMC termination, we have used SuperProve from Berkeley ABC package [30]. The experiments were performed on an Intel Core i5 with 64GB RAM.

Table II captures the results of attacking the ISCAS'89 benchmarks when encoded using duplicated states (SSD), obfuscated using deep faults (DF), protected using a combination of both techniques (DFSSD). The first few columns of the table describe the characteristics of these benchmarks in terms of number of flip-flops (FF), number of primary I/O (PI and PO), and number of unreachable states (URS) according to [29]. In this table DF w represent a DF obfuscation, constructed using a counter of width w . For each obfuscated circuit, number of discovered DISes, and the number of inputs in the last DIS (its length) is reported as D/S. The maximum attack time is set to eight hours. Attacks that take longer are reported as TO .

The SSD column of Table II captures the result of UB-SAT attack against circuits protected only by Shallow State Duality. As expected, when UB-SAT is deployed against a SSD encoded circuit, the UC And CE termination strategies become useless. As reported, for all SSD-encoded benchmarks, either the attack is terminated by UMC or prematurely terminated for lack of memory resources.

TABLE II

EXPERIMENTAL RESULTS FOR SHALLOW STATE DUALITY (SSD) AND DEEP FAULTS (DF) METHODS. ITERATION OF LAST DIS (D) AND ITS LENGTH (S) IS REPORTED IN D/S COLUMNS. TIME IS IN SECONDS. SUCCESSFUL TERMINATION CONDITION IS REPORTED IN *Term* COLUMN.

Circuit	Circuit Info				Shallow State Duality									Deep Faults												DFSSD					
	URS count from [29]				SSD			DF3			DF4			DF5			DF7			SSD + DF5			SSD + DF7								
	FF	PI	PO	URS	D/S	Time	Term	D/S	Time	Term	D/S	Time	Term	D/S	Time	Term	D/S	Time	Term	D/S	Time	Term	D/S	Time	Term						
s344	15	9	11	9,536	0	9	UMC	29/8	39	UC	56/16	139	UC	119/32	2849	UC	-	TO	-	115/32	5231	UMC	-	TO	-						
s382	21	3	6	2,073,412	0	5	UMC	17/48	9393	UMC	-	TO	-	-	TO	-	-	TO	-	-	TO	-	-	TO	-						
s386	6	7	7	51	0	6	UMC	8/8	9	UC	29/16	45	UC	70/32	482	UC	-	TO	-	65/32	1232	UMC	-	TO	-						
s526	21	3	6	1,695,692	0	5	UMC	27/16	463	UMC	49/32	1580	UMC	92/64	4684	UMC	-	TO	-	90/64	4676	UMC	-	TO	-						
s713	19	35	23	517,625	0	223	UMC	15/8	28	UC	53/16	317	UC	-	TO	-	-	TO	-	-	TO	-	-	TO	-						
s832	5	18	19	7	0	12	UMC	32/16	86	UC	44/16	148	UC	99/32	2549	UC	-	TO	-	-	TO	-	-	TO	-						
s838	32	34	1	$> 2^{30}$	-	TO	-	20/72	1096	UC	43/80	2194	UC	-	TO	-	-	TO	-	-	TO	-	-	TO	-						
s1196	18	14	14	259,492	0	12	UMC	27/8	77	UC	64/16	377	UC	135/32	3146	UC	-	TO	-	-	TO	-	-	TO	-						
s1423	74	17	5	$> 2^{72}$	-	TO	-	8/8	26	UC	49/16	2924	UC	-	TO	-	-	TO	-	-	TO	-	-	TO	-						
s1494	6	8	19	16	0	15	UMC	21/8	46	UC	78/16	369	UC	187/32	4333	UC	-	TO	-	-	TO	-	-	TO	-						
s5378	179	35	49	$> 2^{176}$	0	65	UMC	42/8	1653	UC	-	TO	-	-	TO	-	-	TO	-	-	TO	-	-	TO	-						
s9234	211	36	39	$> 2^{227}$	0	3065	UMC	-	TO	-	-	TO	-	-	TO	-	-	TO	-	-	TO	-	-	TO	-						
s38584	1426	38	304	$> 2^{1449}$	-	TO	-	8/8	1293	UC	-	TO	-	-	TO	-	-	TO	-	-	TO	-	-	TO	-						

Table II also captures the results of attacking circuits, which are obfuscated using deep faults with varying counter widths (3, 4, 5, and 7 bits). From this table, following observations are made: 1) the number of discovered DISes grow exponentially with respect to the size of the counter. This is consistent with the Lemma 1: at each cycle we can produce at least 1 DIS until the protected pattern (which in this case is encoded using the highest value of the counter) is reached. Hence, we should at least have 2^w DISes. 2) The size of the largest input sequence (S) in which the deep fault is discovered is $N \times 2^w$ (N being an integer). This is consistent with Lemma 1, where the protected pattern could be potentially (but not necessarily) observed at every $N \times 2^w$ cycles; 3) the runtime of the attack increases exponentially as the depth of DF tracer circuit (counter) increases; and 4) when the circuit is solely protected by DF, the UC termination is the most reoccurring termination strategy.

The last two columns of Table II, capture the impact of combining the DF and SSD (DFSSD) which is the main solution proposed in this paper. The DFSSD combines the best feature of the two solutions. The SSD prevents early UC and CE termination, while the DF pushes the faults down into deep states, resulting in an exponential increase in the number of required DISes and the attack time with respect to the counter size. Note that by preventing the UC and CE terminations, and by forcing the attack to UMC termination check in every iteration, the SSD+DF5 has considerably larger runtime compared to DF5.

V. CONCLUSION

In this paper, we proposed DFSSD, an obfuscation solution for FSM and sequential circuits with restricted (locked) access to the scan chain. The DFSSD deployed two mechanisms, specifically designed to resist against BMC-based attacks such as UB-SAT: 1) it uses shallow state duality to prevent early termination of such attacks by invalidating the unique completion and combinational equivalence checks, forcing the attack to rely on exhaustive and time-consuming UMC for assessing the attack's termination condition; 2) it injects fault into deep and hard to reach (by a BMC) states. The DFSSD allows the designer to precisely control the depth of the fault at design time using a low overhead circuit solution and make the attack time unreasonably long.

VI. ACKNOWLEDGEMENT

This research is funded by the Defense Advanced Research Projects Agency (DARPA #FA8650-18-1-7819) of the USA, and partly by Silicon Research Co. (SRC TaskID 2772.001) and National Science Foundation (NSF Award# 1718434).

REFERENCES

- A. Yeh, "Trends in the Global IC Design Service Market," *DIGITIMES research*, 2012.
- K. Zamiri Azar et al., "Threats on Logic Locking: A Decade Later," in *Proceedings of the 2019 on Great Lakes Symposium on VLSI (GLSVLSI)*. ACM, 2019, p. 471476.
- K. Zamiri Azar et al., "COMA: Communication and Obfuscation Management Architecture," in *22nd International Symposium on Research in Attacks, Intrusions and Defenses (RAID)*. USENIX Association, Sep. 2019, pp. 181–195.
- P. Subramanyan et al., "Evaluating the Security of Logic Encryption Algorithms," in *IEEE Int'l Symp. on Hardware Oriented Security and Trust (HOST)*, 2015, pp. 137–143.
- M. El Massad et al., "Integrated Circuit (IC) Decamouflaging: Reverse Engineering Camouflaged ICs within Minutes," in *Proc. of NDSS*, 2015, pp. 1–14.
- S. Roshanisefat et al., "Benchmarking the Capabilities and Limitations of SAT Solvers in Defeating Obfuscation Schemes," in *2018 IEEE 24th International Symposium on On-Line Testing and Robust System Design (IOLTS)*, July 2018, pp. 275–280.
- M. Yasin et al., "Provably-secure logic locking: From theory to practice," in *ACM SIGSAC Conf. on Computer and Communications Security (CCS)*, 2017, pp. 1601–1618.
- Y. Xie et al., "Delay Locking: Security Enhancement of Logic Locking against IC Counterfeiting and Overproduction," in *Design Automation Conf. (DAC)*, 2017, pp. 1–9.
- S. Roshanisefat et al., "SAT-hard Cyclic Logic Obfuscation for Protecting the IP in the Manufacturing Supply Chain," in *IEEE Tran. on Very Large Scale Integration Systems (TVLSI)*, 2020.
- H. Mardani Kamali et al., "LUT-Lock: A Novel LUT-Based Logic Obfuscation for FPGA-Bitstream and ASIC-Hardware Protection," in *2018 IEEE Computer Society Annual Symposium on VLSI (ISVLSI)*, July 2018, pp. 405–410.
- H. Mardani Kamali et al., "Full-Lock: Hard Distributions of SAT Instances for Obfuscating Circuits Using Fully Configurable Logic and Routing Blocks," in *Design Automation Conf. (DAC)*, 2019.
- G. Kolhe et al., "On Custom LUT-Based Obfuscation," in *Proceedings of the 2019 on Great Lakes Symposium on VLSI, ser. GLSVLSI 19*. New York, NY, USA: Association for Computing Machinery, 2019, p. 477482.
- M. Yasin et al., "Security Analysis of Anti-SAT," in *2017 22nd Asia and South Pacific Design Automation Conference (ASP-DAC)*, Jan 2017, pp. 342–347.
- D. Sironi et al., "Functional Analysis Attacks on Logic Locking," in *2019 Design, Automation Test in Europe Conference Exhibition (DATE)*, March 2019, pp. 936–939.
- K. Zamiri Azar et al., "SMT Attack: Next Generation Attack on Obfuscated Circuits with Capabilities and Performance Beyond the SAT Attacks," *Tran. on Cryptographic Hardware and Embedded Systems (TCHES)*, pp. 97–122, 2019.
- U. Guin et al., "Robust Design-for-Security Architecture for Enabling Trust in IC Manufacturing and Test," *IEEE Tran. on Very Large Scale Integration (VLSI) Systems*, vol. 26, no. 5, 2018.
- N. Limaye et al., "Is Robust Design-for-Security Robust Enough? Attack on Locked Circuits with Restricted Scan Chain Access," *CoRR*, vol. abs/1906.07806, 2019.
- M. El Massad et al., "Reverse Engineering Camouflaged Sequential Circuits without Scan Access," in *IEEE/ACM Int. Conf. on Computer-Aided Design (ICCAD)*, 2017, pp. 33–40.
- R. Karmakar et al., "Encrypt Flip-Flop: A Novel Logic Encryption Technique For Sequential Circuits," 2018.
- X. Wang et al., "Secure Scan and Test Using Obfuscation Throughout Supply Chain," *IEEE Tran. on Computer-Aided Design of Integrated Circuits and Systems*, vol. 37, no. 9, Sep. 2018.
- L. Alrahis et al., "ScanSAT: Unlocking Obfuscated Scan Chains," in *Proc of the Asia and South Pacific Design Automation Conf.*, 2019, pp. 352–357.
- K. Shami et al., "KC2: Key-Condition Crunching for Fast Sequential Circuit Deobfuscation," in *2019 Design, Automation Test in Europe Conference Exhibition (DATE)*, March 2019.
- E. M. Clarke et al., *Model Checking and the State Explosion Problem*. Springer, 2012, pp. 1–30.
- M. Mneimneh et al., "SAT-based Sequential Depth Computation," in *Proceedings of the 2003 Asia and South Pacific Design Automation Conference*. ACM, 2003, pp. 87–92.
- M. Yasin et al., "SARLock: SAT Attack Resistant Logic Locking," in *IEEE Int'l Symp. on Hardware Oriented Security and Trust (HOST)*, 2016, pp. 236–241.
- Y. Xie et al., "Mitigating SAT Attack on Logic Locking," in *Cryptographic Hardware and Embedded Systems – CHES 2016*. Springer, 2016, pp. 127–146.
- P. Subramanyan et al., "Reverse engineering digital circuits using functional analysis," in *2013 Design, Automation Test in Europe Conference Exhibition (DATE)*, March 2013, pp. 1277–1280.
- B. Shakya et al., "Covert Gates: Protecting Integrated Circuits with Undetectable Camouflaging," *IACR Tran. on Cryptographic Hardware and Embedded Systems*, vol. 2019, no. 3, May 2019.
- H. Yotsuyanagi et al., "Undetectable fault removal of sequential circuits based on unreachable states," in *Proceedings. 16th IEEE VLSI Test Symposium*, April 1998, pp. 176–181.
- B. Sterin et al., "The benefit of concurrency in model checking," in *Proceedings of the International Workshop on Logic Synthesis, IWLS*, 2011, pp. 176–182.