

Rich-Item Recommendations for Rich-Users via GCNN: Exploiting Dynamic and Static Side Information

Amar Budhiraja*
Microsoft Research
amar.budhiraja@microsoft.com

Gaurush Hiranandani*
UIUC
gaurush2@illinois.edu

Navya Yarrabelly
Microsoft Research
navya.yarrabelly@gmail.com

Ayush Choure
Microsoft Research
aychoure@microsoft.com

Oluwasanmi Koyejo
UIUC
sanmi@illinois.edu

Prateek Jain
Microsoft Research
prajain@microsoft.com

January 29, 2020

Abstract

We study the standard problem of recommending relevant *items* to *users*; a *user* is someone who seeks recommendation, and an *item* is something which should be recommended. In today’s modern world, both *users* and *items* are ‘rich’ multi-faceted entities but existing literature, for ease of modeling, views these facets in silos. In this paper, we provide a general formulation of the recommendation problem that captures the complexities of modern systems and encompasses most of the existing recommendation system formulations. In our formulation, each *user* and *item* is modeled via a set of static entities and a dynamic component. The relationships between entities are captured by multiple weighted bipartite graphs. To effectively exploit these complex interactions for recommendations, we propose MEDRES— a multiple graph-CNN based novel deep-learning architecture. In addition, we propose a new metric, $pAp@k$, that is critical for a variety of classification+ranking scenarios. We also provide an optimization algorithm that directly optimizes the proposed metric and trains MEDRES in an end-to-end framework. We demonstrate the effectiveness of our method on two benchmarks as well as on a message recommendation system deployed in Microsoft Teams where it improves upon the existing production-grade model by 3%.

*Equal Contribution.

1 Introduction

Recommendation systems are now a mainstay of most online systems and has been modeled using various approaches [10, 4, 20]. However, typical formulations simplify the entire system significantly, e.g., modeling users and items as a single static entity (collaborative filtering) or manually design representations with possible side-information in the form of a graph over users/items (content filtering). While such simple abstractions provide tractable formulations that can be addressed using rigorous algorithms, they ignore key subtleties of the product environment. In a product system, information is available in multiple and varied forms, all of which may be important for the recommendation module to perform to its full potential. To capture all the information in the system and yet avoid the need for changing the model formulation with the addition of a new form of information, several practical recommender systems adhere to the *content filtering* based approaches. In these approaches, all the joint features for (user, item) tuples, which are extracted from the product, are fed into a classifier [12]. However, designing features for these approaches is difficult especially for real-world systems with several sources of information. Consequently, such methods suffer from several issues such as poor accuracy and difficult maintenance cycle.

In this paper, we propose a general formulation for the recommendation problem to address the above-mentioned issues. In particular, we model the real-world scenarios by considering two types of entities: (a) *static* and (b) *dynamic*. In a given time window, static entities are (mostly) fixed while dynamic entities are generated and modified at a high rate. For example, consider the citation prediction problem [22] where the goal is to predict the set of papers that should be cited by a given paper. Here, the authors and the conferences represent the static entities because these are fixed in a considerably large time window; whereas, the content of the paper (e.g. title/abstract) represent the dynamic entities, as they are generated at a considerably high frequency.

Given this notion of static and dynamic entities, we formalize a *user* – an entity which seeks out the recommendation – as a collection of static entities as well as a dynamic component. For example, consider an author who is seeking citation recommendations for her paper in preparation, which she plans to submit to a particular conference venue. Here, the user (i.e. the paper) is composed of static entities such as author and conference venue while it’s dynamic component is the paper title or abstract. Similarly, we formulate an item – an entity to be recommended – also as a collection of static entities and a dynamic component. For example, the research papers to be recommended are again composed of their authors (static), conference venues (static) where they were published and their title or abstract (dynamic). We call this representation a ‘rich’ representation of users and items. Notice that many items or users may have the same static entities but a different dynamic component.

In general, there is a multitude of behavioral information from the past regarding interaction between the static entities. These interactions can be represented using graphs since graphs are natural data structures to represent various relationships/engagements between different entities. One example is the author-conference graph, where an edge denotes the number of papers an author has published in a particular conference. Typical systems would have multiple such graphs among the entities. Finally, we assume a labeled training dataset where for a given (user, item) pair, we have the ground-truth about how relevant the item is for the user.

In summary, we formulate the problem as finding relevance of an item for a user, where the user and the item are represented by multiple static entities and individual dynamic components. The training data consists of labeled (user, item) tuples and multiple bi-partite graphs between

static entities. For this formulation, we propose a novel architecture, Multiple Entity based Deep REcommendation System (MEDRES), that exploits recent advances in graph convolutional neural networks (GCNN). In particular, we use graph convolutions to embed each entity in a vector space via combining information from multiple graphs for that entity. We then concatenate the entity embeddings with the dynamic component to obtain richer representations of users and items. These representations are then fed to a multi-layer perceptron (MLP) to infer how relevant an item is for a user. MEDRES is end-to-end architecture that can be trained for the required metric.

For several problem domains that we consider such as enterprise message recommendation in Microsoft Teams (MSTeams), where users have heterogeneous engagement profiles, standard metrics such as AUC, partial-AUC, and Precision@k [2, 15, 11] quite often fail to capture the key nuances and can portray an algorithm incorrectly. For example, AUC is in general larger for problems with very few relevant items in the dataset. Similarly, when the number of relevant items are much bigger than k , then partial-AUC may be high even when irrelevant items occur in top- k . On the other hand, Precision@k is same for the two rankings containing same number of relevant and irrelevant items in top- k without considering the ordering among the top- k .

To this end, we design a new classification+ranking metric: partial-AUC + precision@k (pAp@k). Our metric can be seen as a combination of both partial-AUC and precision@k. It rewards presence of every relevant item over irrelevant items in top- k scored elements (ranking aspect) and penalizes presence of irrelevant items in top- k over relevant items outside top- k (classification aspect). We formalize the metric and provide an optimization algorithm for the same. The metric is used in a production system deployed by MSTeams.

Finally, we study the wide-applicability of our formulation and effectiveness of our algorithm via two publicly available datasets: a) citation dataset, b) Flickr dataset. For both these datasets, we show how challenging recommendation problems can easily be instantiated in our framework, and can provide more accurate recommendations than standard baselines. We also show similarly impressive gains over a production-grade model for a message recommendation system deployed in MSTeams. In summary, our contributions are as follows:

- We propose a new formulation for the recommendation problem in large systems which effectively captures dynamically generated content, static entities, and multiple relationships among the static entities (Section 2).
- We propose MEDRES, a multiple Graph-CNN based architecture to exploit the above formulation (Section 3).
- We propose a new metric pAp@k, that captures subtleties in several real-world recommendation systems and provide an algorithm to optimize the proposed metric (Section 3).
- We demonstrate efficacy of the proposed solutions through three disparate applications including a detailed case study of the message recommendation system problem used in MSTeams, an enterprise product with millions of active users. We compare our method against a production-grade model developed over 1-2 years and show that our method is able to significantly outperform it after a few hours' worth of training (Section 4).

2 Problem Formulation

Given a user/document \mathcal{U} and an item \mathcal{I} , the goal is to find relevance score of \mathcal{I} for \mathcal{U} . Both \mathcal{U} and \mathcal{I} are complex entities with several static sub-entities, and a dynamic component. Let $\mathcal{E}^{(1)}, \dots, \mathcal{E}^{(E)}$

be given *entity types* for some $E \in \mathbb{Z}_+$. An entity type can be a set of authors, groups, venues etc. $\mathcal{E}_U^{(i)}$ denotes the i -th entity type for user. For example, if $\mathcal{E}^{(1)}$ denotes the set of groups, then $\mathcal{E}_U^{(1)}$ denotes the group of \mathcal{U} . With these notations in place, \mathcal{U} is now defined as:

$$\mathcal{U} = (\mathcal{E}_U^{(a_1)}, \dots, \mathcal{E}_U^{(a_{k_1})}, \zeta(\mathcal{U})), \quad (1)$$

where each \mathcal{U} is associated with k_1 entity types: $\mathcal{E}^{(a_i)}$, $i \in [k_1]$, and $[k] = \{1, \dots, k\}$ denotes the index set for $k \in \mathbb{Z}_+$. $\zeta(\mathcal{U})$ is the *dynamic* part of \mathcal{U} . For example, for a research paper \mathcal{U} being written for conference C by author A , the entities are conference $\mathcal{E}_U^{conf.} = C$ and author $\mathcal{E}_U^{auth.} = A$. The *dynamic* part is the text of the paper, i.e., $\zeta(\mathcal{U}) \in \mathbb{R}^{D_U}$ can be say D_U -dimensional word2vec embedding [13] of the paper’s abstract and title. Similarly, an item \mathcal{I} is defined as:

$$\mathcal{I} = (\mathcal{E}_{\mathcal{I}}^{(b_1)}, \dots, \mathcal{E}_{\mathcal{I}}^{(b_{k_2})}, \nu(\mathcal{I})), \quad (2)$$

where $\nu(\mathcal{I}) \in \mathbb{R}^{D_I}$ denotes the *dynamic* part of the item with D_I being the dimension of the dynamic component. For instance, a citation item has two static entities (authors and conference venue) and it’s dynamic part is the word-embedding of paper title. Now, the goal would be to recommend citations i.e. a set of items for a new research paper \mathcal{U} .

Additionally, a multitude of behavioral information about static entities can be collected using their past interactions. These interactions are expressed via (multiple) bipartite graphs. For example, we may have an author-conference graph where an edge represents the number of times an author has published at a conference.

We denote these bipartite graphs between entities $\mathcal{E}^{(a)}$, $\mathcal{E}^{(b)}$ as: $G^{a,b} = (V^{a,b}, A^{a,b})$, where $V^{a,b}$ is the set of nodes and $A^{a,b} \in \mathbb{R}^{|\mathcal{E}^{(a)}| \times |\mathcal{E}^{(b)}|}$ is the adjacency matrix of the graph. The rows and columns in $A^{a,b}$ are associated with entity instances of type $\mathcal{E}^{(a)}$ and $\mathcal{E}^{(b)}$, respectively. For any two entity types $\mathcal{E}^{(a)}$ and $\mathcal{E}^{(b)}$, we may have multiple bipartite graphs denoting different interactions. Thus, let $\mathcal{G}^{a,b} = \{G^{a,b,1}, \dots, G^{a,b,|\mathcal{G}^{a,b}|}\}$ be the set of graphs between entities $\mathcal{E}^{(a)}$ and $\mathcal{E}^{(b)}$. Furthermore, let the set of all graphs be represented by $\mathcal{G} = \{G^1, \dots, G^{|\mathcal{G}|}\}$. In addition to such graphs, we are provided the following dataset for training:

$$\mathcal{D} = \{(\mathcal{U}_1, \mathcal{I}_1, y_1), \dots, (\mathcal{U}_n, \mathcal{I}_n, y_n)\}, \quad (3)$$

where $y_i \in \{0, 1\}$ is the label of the i -th (user, item) pair and denotes the relevance of item \mathcal{I}_i for user \mathcal{U}_i . Given all this information, the goal is to find a scoring function that computes relevance of \mathcal{I} for \mathcal{U} . That is, given \mathcal{D} , entities $\mathcal{E}^{(1)}, \dots, \mathcal{E}^{(E)}$, graphs \mathcal{G} , the goal is to find a scoring function $s(\mathcal{U}, \mathcal{I})$ that works best for a certain metric $\mathcal{M}(\mathcal{D})$. For example, for binary labels y_i ’s, the goal would be to find a score s s.t. $s(\mathcal{U}_i, \mathcal{I}_i) > s(\mathcal{U}_j, \mathcal{I}_j)$ if $y_i > y_j$.

Note that most of the existing recommender system formulations can be expressed as a special case of this general formulation. For example, typical collaborative filtering [10] is defined by $\mathcal{U} = (\mathcal{E}^{user})$, $\mathcal{I} = (\mathcal{E}^{item})$. That is, there are only two entity types: the set of users and set of items. Furthermore, users/items do not have any dynamic content. Berg et al. [20] extended this model by considering the ratings graph $G^{\mathcal{U}, \mathcal{I}}$ between users and items. That is, edge $(\mathcal{U}, \mathcal{I})$ exists in graph if \mathcal{U} has given \mathcal{I} a fixed rating. This model is also a special case of our formulation where we have only two types of entities \mathcal{U}, \mathcal{I} , and the only graphs are the ratings graphs.

Similarly, inductive matrix factorization [4] models the problem as: $\mathcal{U} = (\zeta(\mathcal{U}))$, $\mathcal{I} = (\mathcal{E}^{item})$, where the set of entities contains only the item entity itself. $\zeta(\mathcal{U})$ is the dynamic user/document

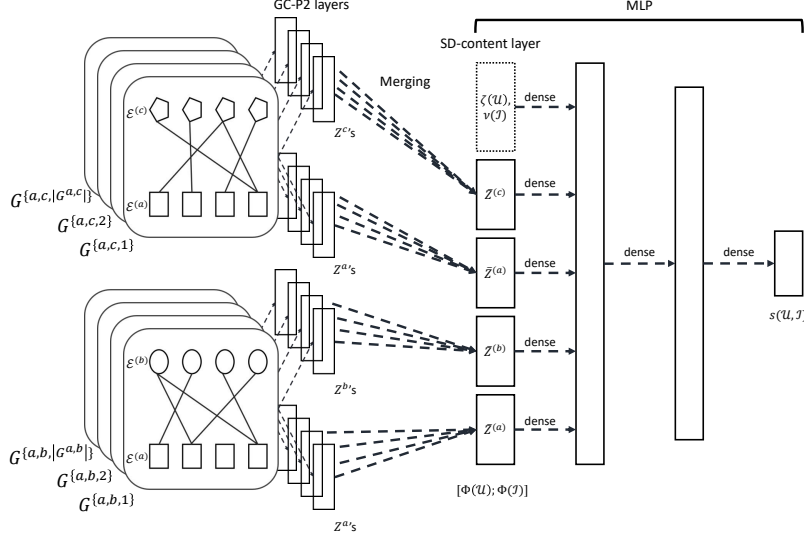

Figure 1: MEDRES: Polynomial-2 Graph-Convolutions provides multiple $GC-P2$ embeddings of entities corresponding to multiple graphs. These embeddings are merged together to obtain multiple $Emb-merge$ embeddings. Dynamic content is augmented with all the $Emb-merge$ embeddings in the $S-D$ Content layer, which is then passed to an MLP for binary classification.

feature of \mathcal{U} . Recently, several papers [17, 14] have studied the matrix completion problem with graph based side-information. Typically, these works model the users/items as: $\mathcal{U} = (\mathcal{E}^{user})$, $\mathcal{I} = (\mathcal{E}^{item})$ with graphs among users as well as items $\mathcal{G} = \{G^{user}, G^{item}\}$. Finally, the standard content filtering approaches [1, 7, 12] do not exploit graph structure and directly models the $(\mathcal{U}, \mathcal{I})$ pair as: $\phi(\mathcal{U}, \mathcal{I})$, i.e., via hand-coded features for \mathcal{U}, \mathcal{I} pair. This shows that most of the existing recommendation problems are a special case of our general framework. Moreover, unlike standard formulations, our general framework leads to a real-world recommendation system that captures much more complex entities and stitches together various sources of information.

3 Method

We first discuss our architecture MEDRES that stitches several types of interactions amongst multiple entities to recommend \mathcal{I} 's for \mathcal{U} 's. Then, we discuss the new metric, $pAp@k$, which appropriately measures the effectiveness of a recommendation system in a classification+ranking scenario such as ours. Lastly, we discuss training and inference of MEDRES.

3.1 MEDRES Architecture

Broadly, MEDRES extends ideas from recently proposed graph-CNN techniques [3, 9], which enables it to learn multiple embeddings for all entity instances of every entity type. We then concatenate all these embeddings along with dynamic content to obtain a rich $[\mathcal{U}, \mathcal{I}]$ representations and feed them into an multi-layer perceptron (MLP) network to obtain the final relevance score.

Unlike existing methods [12], which use feature extraction from graphs and a separate classification model, we learn all the parameters simultaneously for training our end-to-end architecture while optimizing the proposed metric $pAp@k$. Please see Figure 1 for visual intuition of the framework.

Let us suppose that we are given a bipartite graph $G^{a,b}$ between two entities $\mathcal{E}^{(a)}$ and $\mathcal{E}^{(b)}$. For simplicity of exposition, let us represent the graph as $G = \{V^{(a)} \cup V^{(b)}, A\}$, where $V^{(a)}$ and $V^{(b)}$ correspond to entity instances of entity types $\mathcal{E}^{(a)}$ and $\mathcal{E}^{(b)}$, respectively, and A is the adjacency between the nodes defined as:

$$A = \begin{pmatrix} 0 & A^{a,b} \\ (A^{a,b})^T & 0 \end{pmatrix}.$$

Let $L = I - D^{-1/2}AD^{-1/2}$ be the normalized graph Laplacian of G , where D is the degree diagonal matrix, and let $\tilde{L} := \frac{2}{\|L\|_2}L - I_{|V|}$. Using Kipf and Welling’s [2016] approximation to convolution operations on graphs, we compute GCN embedding of second order by applying $D_{\text{CN}} \in \mathbb{Z}_+$ convolutional filters to the graph. That is, let $F^{(a)} \in \mathbb{R}^{|V^{(a)}| \times p}$ and $F^{(b)} \in \mathbb{R}^{|V^{(b)}| \times q}$ be the feature matrices of entity instances associated with $\mathcal{E}^{(a)}$ and $\mathcal{E}^{(b)}$, respectively¹. Then, using formulation in [9], we have:

$$\begin{bmatrix} Z^{(a)} \\ Z^{(b)} \end{bmatrix} = \text{Relu} \left((\tilde{L} + I)FW_0 + (2\tilde{L}^2 + \tilde{L} - I)FW_1 \right), \quad (4)$$

where the feature matrix F is given by:

$$F = \begin{bmatrix} F^{(a)} & 0 \\ 0 & F^{(b)} \end{bmatrix}, \quad (5)$$

$Z^{(a)} \in \mathbb{R}^{|V^{(a)}| \times D_{\text{CN}}}$ and $Z^{(b)} \in \mathbb{R}^{|V^{(b)}| \times D_{\text{CN}}}$ are the feature matrices obtained after applying convolutional filters parameterized by matrices W_0 and W_1 , both of which are $(|V^{(a)}| + |V^{(b)}|) \times D_{\text{CN}}$ -dimensional. Here, $\text{Relu}(a) := \max(0, a)$. In the architecture, we call this layer as *GC-P2* layer and the corresponding embeddings such as $Z^{(a)}$ as *GC-P2* embeddings (see Figure 1).

Now, as we discussed in Section 2, there can be multiple graphs between entity types $\mathcal{E}^{(a)}$ and $\mathcal{E}^{(b)}$. For example, interactions such as ‘number of papers published’ and ‘number of papers cited’ in a conference by an author may be represented by two different graphs. We merge all the *GC-P2* embeddings of an entity type emerging from all the interactions with another entity using a fully connected layer. We refer this layer as the *Emb-merge layer*. Formally, let $\mathcal{G}^{a,b}$ be the set of graphs between entities $\mathcal{E}^{(a)}$ and $\mathcal{E}^{(b)}$. Then, we first concatenate all *GC-P2* embeddings i.e. $Z^{(a)}$ ’s (4) of entity instances in $\mathcal{E}^{(a)}$ emerging from the graphs in $\mathcal{G}^{a,b}$ and merge them using a fully connected layer. The same is done for entity instances in $\mathcal{E}^{(b)}$ as described in the following formulation:

$$\bar{Z}^{a,b} = \begin{bmatrix} \bar{Z}^{(a)} \\ \bar{Z}^{(b)} \end{bmatrix} = \text{RELU} \left(\begin{bmatrix} Z_1^{(a)} \dots Z_{|\mathcal{G}^{a,b}|}^{(a)} \\ Z_1^{(b)} \dots Z_{|\mathcal{G}^{a,b}|}^{(b)} \end{bmatrix} \begin{bmatrix} W^{(a)} \\ W^{(b)} \end{bmatrix} + \begin{bmatrix} c^{(a)} \\ c^{(b)} \end{bmatrix} \right) \quad (6)$$

where $\bar{Z}^{a,b} \in \mathbb{R}^{(|V^a|+|V^b|) \times D_{\text{MN}}}$ with D_{MN} being *Emb-merge* layer’s embedding dimensions, $W^{(a)}, W^{(b)} \in \mathbb{R}^{(|\mathcal{G}^{a,b}| * D_{\text{CN}}) \times D_{\text{MN}}}$ and $c^{(a)}, c^{(b)} \in \mathbb{R}^{D_{\text{MN}}}$ are the weights and biases of the *Emb-merge* layer, respectively. Notice that we always have the flexibility to choose different D_{MN} for different entity types. $\bar{Z}^{(a)}$ represents an embedding of entity instances in $\mathcal{E}^{(a)}$ with regards to $\mathcal{E}^{(b)}$. For example, at this stage we have embedding of authors due to all the interactions with conferences.

After utilising all the static information (graphs) to get entity embeddings, now we augment the dynamic content as features. That is, we represent every user/document \mathcal{U} as:

$$\Phi(\mathcal{U}) = [\bar{Z}_{\mathcal{U}}^{1,2}, \bar{Z}_{\mathcal{U}}^{1,3}, \dots, \bar{Z}_{\mathcal{U}}^{E,E}, \zeta(\mathcal{U})], \quad (7)$$

¹In absence of feature vector we can select the one-hot encoding of nodes for $\mathcal{E}^{(a)}$.

where $Z_{\mathcal{U}}^{i,j}$ is the *Emb-merge* embedding of \mathcal{U} from all the graphs between entities $\mathcal{E}^{(i)}$ and $\mathcal{E}^{(j)}$. If \mathcal{U} is not of type $\mathcal{E}^{(i)}$ and $\mathcal{E}^{(j)}$, then $Z_{\mathcal{U}}^{i,j} = 0$. We represent each item \mathcal{I} similarly.

We call the concatenation of user-item representations $[\Phi(\mathcal{U}); \Phi(\mathcal{I})]$ as the *S-D-content* embedding, where S-D stands for ‘static’-‘dynamic’. We then apply MLP layer on the final *S-D-content* as follows:

$$s(\mathcal{U}, \mathcal{I}) = \sigma(\text{RELU}(\text{RELU}([\Phi(\mathcal{U}); \Phi(\mathcal{I})]M_1)M_2)M_3), \quad (8)$$

where M_i ’s are the weight matrices and σ is the sigmoid function (for binary classification problem).

In the experiments (Section 4), we consider two versions of MEDRES. One with polynomial-2 approximation for obtaining the *GC-P2* embeddings. We call it MEDRES-P2. Another version, referred as MEDRES-P1, uses polynomial-1 approximation (i.e. considering only the first term in the *r.h.s* of (4)) to obtain *GC-P1* embeddings. We empirically observe that MEDRES-P2 captures better ‘collaborative filtering’ aspect than MEDRES-P1 in two out of three datasets.

3.2 The Performance Metric – pAp@k

In this section, we discuss a novel metric where the goal is to provide better metric value to scoring functions that generally ranks positives above negatives, especially in top- k items that we recommend. Typical recommendation systems can allow k to be at most a constant. Furthermore, they suffer from heterogeneous engagement problem, i.e., for certain users (or datasets) the number of positives can be very different than other users. So, not only we want good ranking in the top- k recommended items, but also we want to avoid any irrelevant item in those recommendations across varied engagement levels. Unfortunately, most existing metrics like AUC, partial-AUC, NDCG@k, prec@k, etc. do not address the above mentioned problems, hence we introduce our new metric pAp@k which stands for ‘Partial AUC + precision@k’ as it combines key properties of both partial-AUC [15] and precision@k [5].

Suppose we are given a set of labeled points $(x_i, y_i), \dots, (x_n, y_n)$, where $x_i \in \mathcal{X}$ and $y_i \in \{0, 1\}$ and a scoring function $s : \mathcal{X} \rightarrow \mathbf{R}$. Let n_+ be the number of positives (i.e. $y_i = 1$) in the training data and n_- be the set of negatives ($y_i = 0$). Let S^+ be the set of top- β positives ordered by scoring function s where $\beta = \min(n_+, k)$ where k is the number of items to be recommended. Similarly, let S^- be the set of top- k negatives ordered by s . Then,

$$\text{pAp}@k(s) = \frac{1}{\beta k} \sum_{x_i \in S^+} \sum_{x_j \in S^-} \mathbb{1}[s(x_i) \geq s(x_j)], \quad (9)$$

where $\mathbb{1}$ is the indicator function. Note that the metric considers pairwise comparisons between top negative items and top positives items and computes how many times a relevant item has secured higher score than an irrelevant item. Thus, pAp@k rewards presence of every relevant item in top- k scored elements and penalizes high scores of negative items. Also, note that the metric essentially behaves like partial-AUC for $n_+ \ll k$ and like precision@k for $n_+ \gg k$. Since, n_+ can be significantly different for various users (and datasets), our metric provides a more nuanced and comparative evaluation, due to which it is used as the key-performance-indicator by MSTeams’ *production system*.

Algorithm 1 Training MEDRES to optimize pAp@k

Input: TrainingData, Iterations**Output:** MEDRES model

```
1: procedure ITERATIVE TRAINING
2:   SelectedPoints  $\leftarrow$  TrainingData
3:   model  $\leftarrow$  Model_Init()
4:   i  $\leftarrow$  0
5:   while i  $\leq$  Iterations do
6:     model.train(SelectedPoints)
7:     scores  $\leftarrow$  model.score(TrainingData)
8:     SelectedPoints  $\leftarrow$  Select-top(scores, k, ‘-’)  $\cup$ 
       Select-top(scores,  $\beta$ , ‘+’)
9:     i  $\leftarrow$  i+1
10:  end while
11: end procedure
```

We now define the micro and macro versions of pAp@k:

$$\begin{aligned} \text{Micro-pAp@k}(s) &= \frac{1}{P} \sum_p \text{pAp@k}_p(s), \\ \text{Macro-pAp@k}(s) &= \frac{\sum_p \sum_{x_i \in S_p^+} \sum_{x_j \in S_p^-} \mathbf{1}[s(x_i) \geq s(x_j)]}{P \cdot k \cdot \sum_p \beta_p}, \end{aligned} \quad (10)$$

where $\{\mathcal{U}_p\}_{p=1}^P$ are the set of users. We define S_p^+ , S_p^- , β_p for each user p as mentioned above. Finally, pAp@k_p is pAp@k computed for user \mathcal{U}_p . In this paper, we focus on the micro-pAp@k since it is more accommodative of varied engagement level across users and indicative of average of performance per user.

3.3 Training and Inference Pipeline

MEDRES is trained to approximately optimize regularized pAp@k i.e. we hope to find a score function s that minimizes:

$$\mathcal{L} = \ell(\text{pAp@k}(s)) + \tau \sum_j \|W_j\|_2, \quad (11)$$

where the first term is differentiable loss proxy for the metric pAp@k, and τ is the regularizer. To optimize the above function, we need to construct an appropriate (loss) proxy for pAp@k. This is achieved by a novel iterative procedure where in each iteration we store the set of top- β positives and top- k negatives according to the current scoring function. We then optimize the standard cross-entropy based loss on the selected points. To this end, we use Adam [8] optimizer in TensorFlow with mini-batches for learning the weights and subsequent embeddings from multiple bipartite graphs. We then update the score function, and again compute the set of top positives and negatives, and iterate till convergence. See Algorithm 1 for a pseudo-code of the method. Note that $\text{Select-top}(s, k, \text{label})$ function selects top k points of given label when sorted by the score s . Also, the subroutine in line 6 in Algorithm 1 is very fast since it runs on a few selected points.

Table 1: Teams Message Recommendation Dataset Statistics

Statistic	Training Data	Val Data	Test Data
Number of points	3416632	379626	1499083
% of positives	4.40	4.87	4.80
Users	901	898	898
Authors	677	509	593
Channels	476	367	391

We observe that such a procedure optimizes the metric $pAp@k$, and leave further theoretical investigation into convergence and consistency for future work. Note that the graph embeddings are learned only using the training data but are used for inference along with the unseen dynamic content.

4 Experiments

We now demonstrate the wide-applicability and effectiveness of our method on three problems from disparate domains. These are: (a) message recommendation system for Microsoft Teams (aka message-reco), (b) citation recommendation for research papers (aka citation-reco), and (c) group recommendation for photos (aka group-reco).

4.1 Datasets

Message-Reco: The task is to predict the relevance of a given message for a given user. This problem commonly arise in notification or activity feed systems such as in MSTeams. Each message is associated with three static and one dynamic entity. Static entities are: (a) user consuming the message, (b) author of the message, and (c) channel where the message is posted. Dynamic entity is the content of the message. We consider six months of interaction data to construct graphs between static entities. This gives us 23 directed graphs between users and authors, e.g. messages sent from user to author, numbers of actions such as likes by a user on an author’s messages, etc. Similarly, we have 12 directed graphs between users and channels, e.g. how many times a user posted on a channel, how many times a user liked a message posted on a channel, etc. We then collect data from the next 4 weeks of logs from MSTeams and label a (user, message)-tuple to be positive if a user engages with the message in some manner and mark it to be negative otherwise. We divide our collected data, i.e., labeled user-message tuples into train, validation, and test datasets where two weeks of data is used for training, onw week for validation, and one week’s data for test. Further statistics about the dataset are mentioned in Table 1.

Citation-Reco: For the citation-reco. problem, we extract data from the Citation-network V1 – a publicly available dataset [19]. The goal of the problem is to recommend relevant citations for a paper being written. The static entities in this problem are - users who are writing a new paper, authors of the already published papers, and conferences where the candidate recommendations have been published; the title and abstract of the paper being written and the one that is being considered for recommendation are dynamic entities. For creating entity graphs and training data, we use citation data from 1998-2002. The validation and test datasets are created using citation data from 2003 and 2004-2005, respectively. We consider 3 graphs between users and authors for

Table 2: Citation Recommendation Dataset Statistics

Statistic	Train Data	Val Data	Test Data
Number of points	238740	84302	85670
% of positives	9.99	9.40	9.48
Users	1602	962	1003
Authors	1147	949	1019
Conferences	951	881	913

Table 3: Flickr Recommendation Dataset Statistics

Statistic	Training Data	Val Data	Test Data
Number of points	261115	20139	59763
% of positives	12.87	12.24	12.72
Users	839	205	439
Groups	464	422	453
Photos	3837	289	864
Entities	311	284	304
Categories	1471	1294	1413

co-authorship, author-cited-user and user-cited-author. For user and conferences, we consider 2 graphs - user-published-in-conference and user-cited-conference. For each paper, we embed the paper titles using 50-dimensional GloVe [16] embedding vectors. For a given paper, every author and the cited paper pairs make our positive data points. If a user has cited any paper of an author in the given time window but has not cited her some other papers, then the later papers are considered as negative data points. We further sample this data such that a user and each author should have at least 20 data points in the training set. Table 2 provides key statistics of the training and the test dataset.

Group-Reco: For the group-reco. problem, we consider the openly available Flickr dataset [21]. The goal of the problem is to recommend groups to a user who plans to post new photos. Each group is defined by a set of ‘tags’ and ‘categories’, which in layman terms are topics of the groups. For this problem, we consider 4 static entities - users, tags, categories, and groups and 3 graphs between these entities i.e. users-posted-with-tags, users-posted-in-categories, and users-posted-in-groups. We vectorize each image (dynamic component) using VGG19 [18] to 4096 dimensional vectors and further apply PCA to reduce the image feature dimensions to 100. Each time a user posts in a group is considered as a positive datapoint. Negatives are generated by random sampling. Further details about the Flickr dataset are given in Table 3.

4.2 Setup

We compare our proposed MEDRES approach with two standard content-filtering baselines - LightGBM [6] and Multilayer Neural Networks (NN); later in Section 4.5 we will compare MEDRES with a strong collaborative-filtering baseline. For both the baselines, we create features by using the value of 1-hop edges from the graphs along with the features of the dynamic entities. The LightGBM baseline is similar to the production model. For LightGBM, we sweep on the following hyper-parameters: learning rate $\{10^{-3}, 10^{-2}\}$, number of trees $\{50, \dots, 300\}$, and number of

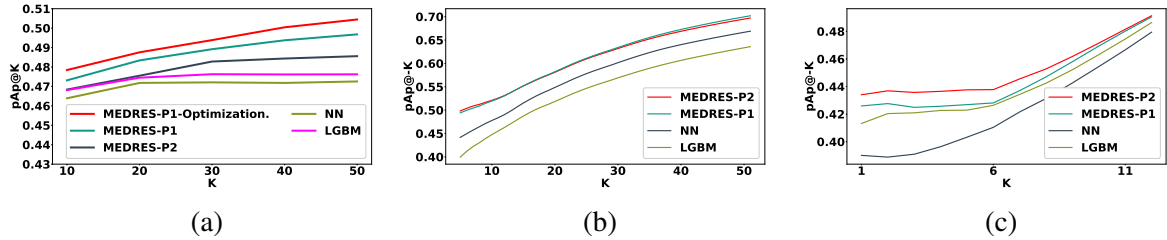

Figure 2: (a) Message-reco: MEDRES-P1 is 2% more accurate than baseline; optimization algorithm (Algorithm 1) further boosts the accuracy by $\sim 1\%$. (b) citation-reco: MEDRES-P1 and MEDRES-P2 are both 4 – 5% more accurate than baselines. (c) group-reco: for $k \leq 6$, MEDRES-P2 is about 3.5% more accurate than baselines.

leaves $\{10, 15, \dots, 30\}$. For the NN baseline, we sweep on the following hyper-parameters: weight regularization $\{10^{-5}, 10^{-6}, 10^{-7}\}$, nodes in each layer $\{2^7, \dots, 2^{10}\}$, batch size $\{3, 5, 10\} \times 10^3$, and learning rate $\{10^{-3}, 10^{-4}\}$. For MEDRES, the cross-validation is done on embedding size $\{2^5, 2^6, 2^7\}$, regularization parameter $\{10^{-4}, 10^{-5}\}$, nodes in fully connected layers $\{2^7, \dots, 2^{10}\}$, batch size $\{1, 3, 5\} \times 10^3$, and learning rate $\{10^{-3}, 10^{-4}\}$. We report only Micro-pAp@k (10) in the experiments as stated earlier in the paper, and refer it as pAp@k throughout this section.

4.3 Results

Figure 2(a) reports pAp@k (10) for various methods for message-reco problem. Recall that Light-GBM model and NN model use a standard content-filtering approach where joint features for (user, message) pair are computed by concatenating standard one-hop edges from the graphs mentioned above. In fact, Light-GBM is very close to the deployed production model. It can be seen that our algorithms perform significantly better than the baseline methods. For example, our method is $\approx 2.1\%$ better than the baselines in terms of pAp@k with $k = 30$. Relatively, we observe an increase of 4.41% in pAp@k. Note that MEDRES also uses MLP as the final classifier, so significant gains over baseline NN (i.e. MLP) models can be directly attributed to MEDRES exploiting the graph based side-information carefully. Figure 2(b) shows pAp@k obtained by various methods with varying k for the citation-reco problem. For recommending $k = 10$ articles, MEDRES-P2 is (\geq)4.37% more accurate than both the baselines and similar trend holds for varying values of k . We observe a similar trend for the group-reco problem (see Figure 2(c)) where MEDRES-P2 is significantly more accurate than the baseline methods. For example, for $k = 5$, MEDRES-P2 is 3.90% more accurate than LGBM.

4.4 Comparison with lesser number of graphs

Next, we study the performance of various methods when provided with different amount of graph signals. That is, we compare the results of the LGBM (a method similar to the production model) and the MEDRES method with varying number of graphs for the message-reco dataset. Table 4 shows a comparison when we use 2 graphs (1 for user-author interaction and 1 for user-channel interaction) and when we use 10 graphs (5 for user-author interactions and 5 for user-channel interactions). As we can see, MEDRES performs better by at least 2.5% points when there are only 2 graphs. LGBM baseline is more severely impacted when the number of graphs are reduced

Table 4: Message-reco: MEDRES is able to achieve similar accuracy as the *production model* with a small number of graph signals.

k	#Graphs = 2 (1 each)		#Graphs = 10 (5 each)	
	LGBM	MEDRES	LGBM	MEDRES
10	0.44710	0.4680	0.4621	0.4635
20	0.4484	0.4745	0.4674	0.4749
30	0.4517	0.4776	0.4706	0.4821
40	0.4511	0.4780	0.4710	0.4847
50	0.4524	0.4786	0.4726	0.4857

Table 5: pAp@30 for Direct Embeddings and MEDRES with different subsamples of training dataset for the message reco. dataset.

	50% Data	70% Data	100% Data
Direct Emb.	0.3361	0.3808	0.3966
MEDRES	0.4729	0.4813	0.4892

to 1 each for lower k values. At $k = 10$, LGBM drops from 0.468 (all 35 graphs) to 0.4471 which is approx. a 2% points dip; whereas, MEDRES is more stable with a drop from 0.4731 to 0.4680 i.e. 0.5% points. Thus, relatively LGBM baseline drop four times more severely than MEDRES. Moreover, the difference in LGBM baseline at $k = 50$ for 10 graphs and all 35 graphs is less than 0.5% points; whereas for MEDRES is more than 1% points. This indicates that the production model is getting saturated earlier, but MEDRES is still able to learn more signal when more graphs are available.

4.5 Direct Embedding vs MEDRES

Finally, we study the importance of the graph side-information in our architecture. As the entities are static, we can learn the embeddings $\phi(\mathcal{U})$ from scratch rather than learning it from the graph. That is, similar to collaborative filtering (CF), $\phi(\mathcal{U})$ can be set to be an arbitrary vector that needs to be learned by minimizing training loss instead of constraining the vector to be generated by GCN, i.e., the system ignores the graph information completely. We refer to this method as direct embedding or non-linear CF. Intuitively, if the amount of training data is large than direct embedding should be able to learn $\phi(\mathcal{U})$ accurately. However, for low-training data regime, graph information would be critical to generalize to users/items with a small amount of training data. Our experiments indeed confirm this intuition. In Table 5, we report the accuracy of both the direct embedding method as well as MEDRES on message-reco problem when trained with a varying fraction of data. Note that even when trained with all the data, Direct Embedding is $\approx 9\%$ less accurate than MEDRES. However, the gap increases to 14% when both the methods are trained with 50% of the available data. This indicates that the graph information for various entities are acting as regularization and MEDRES generalizes significantly better than the collaborative filtering architectures.

References

- [1] Hyung Jun Ahn. A new similarity measure for collaborative filtering to alleviate the new user cold-starting problem. *Information Sciences*, 178(1):37–51, 2008.
- [2] Corinna Cortes and Mehryar Mohri. Auc optimization vs. error rate minimization. In *Advances in Neural Information Processing Systems*, pages 313–320, 2004.
- [3] Michaël Defferrard, Xavier Bresson, and Pierre Vandergheynst. Convolutional neural networks on graphs with fast localized spectral filtering. In *Advances in Neural Information Processing Systems*, pages 3844–3852, 2016.
- [4] Prateek Jain and Inderjit S Dhillon. Provable inductive matrix completion. *arXiv preprint arXiv:1306.0626*, 2013.
- [5] Purushottam Kar, Harikrishna Narasimhan, and Prateek Jain. Surrogate functions for maximizing precision at the top. In *International Conference on Machine Learning*, pages 189–198, 2015.
- [6] Guolin Ke, Qi Meng, Thomas Finley, Taifeng Wang, Wei Chen, Weidong Ma, Qiwei Ye, and Tie-Yan Liu. Lightgbm: A highly efficient gradient boosting decision tree. In *Advances in neural information processing systems*, pages 3146–3154, 2017.
- [7] Heung-Nam Kim, Inay Ha, Kee-Sung Lee, Geun-Sik Jo, and Abdulmotaleb El-Saddik. Collaborative user modeling for enhanced content filtering in recommender systems. *Decision Support Systems*, 51(4):772–781, 2011.
- [8] Diederik P Kingma and Jimmy Ba. Adam: A method for stochastic optimization. *arXiv preprint arXiv:1412.6980*, 2014.
- [9] Thomas N Kipf and Max Welling. Semi-supervised classification with graph convolutional networks. *arXiv preprint arXiv:1609.02907*, 2016.
- [10] Yehuda Koren, Robert Bell, and Chris Volinsky. Matrix factorization techniques for recommender systems. *Computer*, (8):30–37, 2009.
- [11] Quoc Le and Alexander Smola. Direct optimization of ranking measures. *arXiv preprint arXiv:0704.3359*, 2007.
- [12] Xin Li and Hsinchun Chen. Recommendation as link prediction in bipartite graphs: A graph kernel-based machine learning approach. *Decision Support Systems*, 54(2):880–890, 2013.
- [13] Tomas Mikolov, Ilya Sutskever, Kai Chen, Greg S Corrado, and Jeff Dean. Distributed representations of words and phrases and their compositionality. In *Advances in Neural Information Processing Systems*, pages 3111–3119, 2013.
- [14] Federico Monti, Davide Boscaini, Jonathan Masci, Emanuele Rodola, Jan Svoboda, and Michael M Bronstein. Geometric deep learning on graphs and manifolds using mixture model cnns. In *Computer Vision and Pattern Recognition*, volume 1, page 3, 2017.

- [15] Harikrishna Narasimhan and Shivani Agarwal. Support vector algorithms for optimizing the partial area under the roc curve. *Neural computation*, 29(7):1919–1963, 2017.
- [16] Jeffrey Pennington, Richard Socher, and Christopher D Manning. Glove: Global vectors for word representation. In *Proceedings of the 2014 conference on empirical methods in natural language processing (EMNLP)*, pages 1532–1543, 2014.
- [17] Nikhil Rao, Hsiang-Fu Yu, Pradeep K Ravikumar, and Inderjit S Dhillon. Collaborative filtering with graph information: Consistency and scalable methods. In *Advances in Neural Information Processing Systems*, pages 2107–2115, 2015.
- [18] Karen Simonyan and Andrew Zisserman. Very deep convolutional networks for large-scale image recognition. *arXiv preprint arXiv:1409.1556*, 2014.
- [19] Jie Tang, Jing Zhang, Limin Yao, Juanzi Li, Li Zhang, and Zhong Su. Arnetminer: Extraction and mining of academic social networks. In *KDD'08*, pages 990–998, 2008.
- [20] Rianne van den Berg, Thomas N Kipf, and Max Welling. Graph convolutional matrix completion. *stat*, 1050:7, 2017.
- [21] Yueyang Wang, Yuanfang Xia, Siliang Tang, Fei Wu, and Yueting Zhuang. Flickr group recommendation with auxiliary information in heterogeneous information networks. *Multimedia Systems*, 23(6):703–712, 2017.
- [22] Xiao Yu, Quanquan Gu, Mianwei Zhou, and Jiawei Han. Citation prediction in heterogeneous bibliographic networks. In *SIAM International Conference on Data Mining*, pages 1119–1130. SIAM, 2012.