

Classifying Pattern and Feature Properties to Get a $\Theta(n)$ Checker and Reformulation for Sliding Time-Series Constraints

N. Beldiceanu¹, M. Carlsson², C.-G. Quimper³ and M. I. Restrepo¹

¹TASC (LS2N-CNRS), IMT Atlantique, FR – 44307 Nantes, France

²RISE SICS, Sweden

³Laval University, Québec, Canada

Abstract. Given, a sequence \mathcal{X} of n variables, a time-series constraint CTR using the **Sum** aggregator, and a sliding time-series constraint enforcing the constraint CTR on each sliding window of \mathcal{X} of m consecutive variables, we describe a $\Theta(n)$ time complexity checker, as well as a $\Theta(n)$ space complexity reformulation for such sliding constraint.

1 Introduction

While sequence constraints on sliding windows were introduced a long time ago for counting and for sum constraints, e.g. see `AMONG_SEQ` in [4,16,8] and `SLIDING_SUM` in [5,13], no sliding automaton constraint was yet introduced, even if automaton constraints were known since 2004 [7,14]. More recently in the context of planning problems, constraints on streams were introduced in [11,12] for comparing pointwise two stream variables or for stating constraints adapted from Linear Temporal Logic. However, in the context of a long sequence or of a data stream [1], imposing a constraint on a full sequence does not make much sense, as we rather want to focus on sliding windows. Compositional time-series constraints combining a regular expression σ , a feature f , and an aggregator g were introduced in [6,2]. We first provide an example of sliding time series constraint.

Example 1. Given a sequence $\mathcal{X} = 3133211222443122$, we want to compute the sum of subsequences of \mathcal{X} corresponding to increasing sequences, i.e. to maximal occurrences of the pattern ' $< (< | =)^* < < <$ ', in every window of size 10 of \mathcal{X} . Such windows are shown in the figure on the right by a dotted line, where each solid line-segment indicates an increasing sequence. The number to the left of each window is the sum of the elements of the window belonging to an increasing sequence located inside the window. Beyond this example we want a generic approach to deal with a variety of patterns and features.

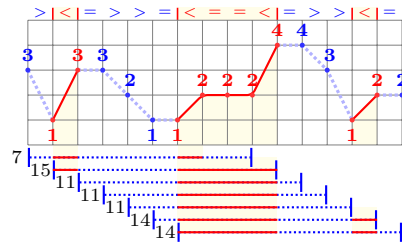

Contributions and methodology Our contributions are threefold.

- By pursuing the compositional style for defining time-series constraints [6], we introduce sliding time-series constraints, assuming g is the `Sum` aggregator. This allows one to define a fair variety of sliding constraints in a generic way, in fact 99 constraints in the time-series catalogue [2].
- It provides a $\Theta(n)$ linear time complexity checker for such constraints, which is crucial when extracting patterns from long sequences in the context of model acquisition [15,18].
- It describes a $\Theta(n)$ linear space complexity reformulation, which allows a memory efficient reformulation.

To obtain our contributions we use the following methodology.

- We come up with three simple equations allowing one to compute the contribution of a window $[i, j]$ (with $i \leq j$) wrt the results (a) on the full sequence $\mathcal{X} = x_1x_2 \dots x_n$, (b) on the prefix $x_1x_2 \dots x_j$ which ends at position j , and (c) on the suffix $x_ix_{i+1} \dots x_n$ which starts at position i .
- We study both the properties of regular expressions and features:
 - We systematically categorise regular expressions by partitioning their words into a restricted set of classes, so that each regular expression can be compactly represented by a finite set of classes.
 - We identify key pattern and feature properties.For each pair of word classes and feature properties, we prove that a given equation holds or provide some counterexample.
- Finally, we show how equations can be directly turned into checkers and reformulations.

The categorisation of a regular expression and the identification of the properties of a pattern are done mechanically by checking that some derived regular languages are empty or not.

Section 2 provides the necessary background on words and time-series constraints. Section 3 introduces a small number of pattern properties, while Section 4 (i) defines the sliding time-series constraints we consider, (ii) classifies regular expressions in relation to sliding windows, (iii) shows how to compute the contribution of a sliding window based on pattern and feature properties, and finally (iv) presents a $\Theta(n)$ time complexity checker and a $\Theta(n)$ space complexity reformulation for such sliding time-series constraints.

2 Background

Word Consider a finite alphabet Σ . A *word* w over Σ is a sequence of letters $w_1w_2 \dots w_\ell$ of the alphabet Σ , and its *length* ℓ is denoted by $|w|$. The *empty word* is denoted by ϵ . The *reverse* of w is the word $w_\ell w_{\ell-1} \dots w_1$ denoted w^r . The concatenation of two words is denoted by putting them side by side. A word v is a *factor* of a word x if there exists two words u and w such that $x = uvw$; when $u = \epsilon$, v is a *prefix* of x , when $w = \epsilon$, v is a *suffix* of x . If v is not empty and different from x , then v is a *proper factor* of x .

Time-series constraints We assume the reader is familiar with regular expressions and automata [10]. A time-series constraint $g_f_σ(r, \mathcal{X})$ is a constraint which restricts an integer result variable r to be the result of some computations over a sequence of integer variables \mathcal{X} . The components of a time-series constraint we reuse from [6] are a *pattern* $σ$, a *feature* f , and an *aggregator* g . A pattern $σ$ is described by a *regular expression* over the alphabet $\Sigma = \{ '<', '=', '>' \}$ whose language $\mathcal{L}_σ$ does not contain the empty word, and by two non-negative integers $b_σ$ and $a_σ$, where $b_σ + a_σ$ is smaller than or equal to the length of the smallest word of $\mathcal{L}_σ$. A feature and an aggregator are functions over integer sequences as illustrated in Table 1. Note that all functions f and g introduced in Table 1 are commutative. Let $\mathcal{S} = s_1 s_2 \dots s_{n-1}$ be the *signature* of a time series \mathcal{X} , which is defined by constraints: $(x_i < x_{i+1} \Leftrightarrow s_i = '<')$ \wedge $(x_i = x_{i+1} \Leftrightarrow s_i = '=')$ \wedge $(x_i > x_{i+1} \Leftrightarrow s_i = '>')$ for all $i \in [1, n-1]$. If a sub-signature $s_i s_{i+1} \dots s_{j-1}$ is a maximal word matching $σ$ in the signature of \mathcal{X} , then the subsequence $x_{i+b_σ} x_{i+b_σ+1} \dots x_{j-a_σ}$ is called a $σ$ -*pattern* wrt \mathcal{X} , and the subsequence $x_i x_{i+1} \dots x_j$ is called an *extended $σ$ -pattern* wrt \mathcal{X} . The non-negative integers $b_σ$ and $a_σ$ trim the left and right borders of an extended $σ$ -pattern to obtain a $σ$ -pattern from which a feature value is computed.

f	value	$σ$	$\mathcal{L}_σ$	$b_σ$	$a_σ$	R	N	O	E	S
one	1	Inflexion	< (< =)* > > (> =)* <	1	1	n	n	y	n	n
width	$j - i - b_σ - a_σ + 1$	BumpOnDecSeq	>><<>>	2	1	n	n	n	n	n
surf	$\sum_{k=i+b_σ}^{j-a_σ} x_k$	DipOnIncSeq	<<>><<	2	1	n	n	n	n	n
		Dec	>	0	0	y	y	n	y	y
max	$\max_{k \in [i+b_σ, j-a_σ]} x_k$	Inc	<	0	0	y	y	n	y	y
min	$\min_{k \in [i+b_σ, j-a_σ]} x_k$	Steady	=	0	0	y	y	n	y	y
		DecTerrace	>=+>	1	1	y	n	n	n	n
		IncTerrace	<=+<	1	1	y	n	n	n	n
		Plain	>=* <	1	1	y	n	y	n	n
		Plateau	<=* >	1	1	y	n	y	n	n
		ProperPlain	>=+ <	1	1	y	n	y	n	n
		ProperPlateau	<=+ >	1	1	y	n	y	n	n
		Gorge	(> (> =)*)* >> (< (< =)*)* <*	1	1	y	n	y	n	n
		Summit	(< (< =)*)* << (> (> =)*)* >*	1	1	y	n	y	n	n
		Peak	< (< =)* (> =)* >	1	1	y	n	y	n	n
		Valley	> (> =)* (< =)* <	1	1	y	n	y	n	n
		DecSeq	> (> =)* > >	0	0	y	y	n	y	n
		IncSeq	< (< =)* < <	0	0	y	y	n	y	n
		SteadySeq	=+	0	0	y	y	n	y	n
		StrictlyDecSeq	>+	0	0	y	y	n	y	n
		StrictlyIncSeq	<+	0	0	y	y	n	y	n
Sum	$\sum_{k=1}^c f_k$	Zigzag	(<>)+ < (> ε) (><)+ > (< ε)	1	1	y	n	n	n	n

Table 1: Consider a sequence $x_1 x_2 \dots x_n$. (Top left) features f with their values computed from an extended $σ$ -pattern $x_i x_{i+1} \dots x_j$; (Bottom left) aggregator $g = \text{Sum}$, its value computed from a sequence of feature values f_1, f_2, \dots, f_c ; (Right) patterns $σ = \langle \mathcal{L}_σ, b_σ, a_σ \rangle$ grouped by the properties they share, where columns R, N, O, E, S respectively indicate whether a pattern has a reverse in the catalogue [3], the NO-INFLEXION, the ONE-INFLEXION, the EXCLUDE-OUT-IN, or the SINGLE LETTER properties.

In the following $x_{i,j}$ denotes the integer subsequence $x_i x_{i+1} \dots x_j$ when $i \leq j$ and $x_i x_{i-1} \dots x_j$ otherwise. The term $f_\sigma(x_{i,j})$ denotes the sum of the values of the feature f from every extended σ -pattern in subsequence $x_{i,j}$, i.e. the contribution of the sliding window $[i, j]$.

3 Pattern Properties

We introduce a limited number of pattern properties¹ that will be used to parameterise our proofs: we will assume that some of these properties hold to prove that a given equation is valid for calculating the contribution of a sliding window.

Definition 1. *The mirror of a regular language \mathcal{L} over $\Sigma = \{ '<', '=', '>' \}$, denoted by \mathcal{L}^{mir} , consists of the mirrors of all the words in \mathcal{L} , where the mirror of a word w , denoted by w^{mir} , has the reverse order of its letters and has all occurrences of the letter '<' flipped into '>' and vice versa.*

Definition 2. *Two patterns $\sigma = \langle \mathcal{L}_\sigma, b_\sigma, a_\sigma \rangle$ and $\sigma^r = \langle \mathcal{L}_{\sigma^r}, b_{\sigma^r}, a_{\sigma^r} \rangle$ are the reverse of each other iff $w \in \mathcal{L}_\sigma \Leftrightarrow w^{\text{mir}} \in \mathcal{L}_{\sigma^r}$, $a_\sigma = b_{\sigma^r}$ and $b_\sigma = a_{\sigma^r}$.*

As shown by column R of the pattern part of Table 1, 19 out of the 22 patterns of the time-series catalogue [3] have a reverse pattern defined inside [3].

Example 2 (reverse). On the one hand, the **Plateau** = $\langle '<=*>', 1, 1 \rangle$ pattern is the reverse of itself since, (1) all letters except the first and last letters of a plateau correspond to the letter '=', (2) the first letter '<' is the mirror of the last letter '>', and (3) $a_{\text{Plateau}} = b_{\text{Plateau}} = 1$. On the other hand, the **Inflexion** = $\langle '< (< | =)* > | > (> | =)* <', 1, 1 \rangle$ pattern is not the reverse of itself: the mirror of the word '<<>>' $\in \mathcal{L}_{\text{Inflexion}}$, i.e. the word '<>>>', is not an inflexion since it ends with two occurrences of '>' rather than one.

Definition 3. *A pattern σ has the CONVEXITY property if for any word $w = s_1 s_2 \dots s_{n-1}$ in \mathcal{L}_σ and for any pair of factors $u = s_c s_{c+1} \dots s_d$ and $v = s_e s_{e+1} \dots s_f$ of w (with $c, d, e, f \in [1, n-1]$) such that, both u and v are words in \mathcal{L}_σ , the word $s_{\min(c,e)} s_{\min(c,e)+1} \dots s_{\max(d,f)}$ is also in \mathcal{L}_σ .*

Example 3 (CONVEXITY property). All patterns of the time series catalogue [3] have the CONVEXITY property, but the pattern whose language is denoted by $\mathcal{L}_{<=>=|<=>}$ has not, since the word '<=>=' in $\mathcal{L}_{<=>=|<=>}$ contains a factor '<=>=' that is not in $\mathcal{L}_{<=>=|<=>}$, for which both the prefix '<=' and the suffix '=>' belong to $\mathcal{L}_{<=>=|<=>}$.

Definition 4. *A pattern σ has the NO-INFLEXION property if any word in its language \mathcal{L}_σ does not simultaneously contain the letters '<' and '>'.*

¹ Through an abuse of language and for reasons of brevity we say "pattern property of σ " rather than "property of the language \mathcal{L}_σ of the pattern σ ".

Definition 5. A pattern σ has the ONE-INFLEXION property if any word in its language \mathcal{L}_σ contains either one, but not both occurrences of ‘<=*>’ and ‘>=*<’.

Definition 6. A pattern σ has the SINGLE LETTER property if all words of \mathcal{L}_σ have a length of one.

Definition 7. A pattern σ has the EXCLUDE-OUT-IN property if for any word $s_1s_2 \dots s_{n-1}$ in \mathcal{L}_σ and for any window $[i, j]$ (with $1 \leq i \leq j \leq n$ and $i > 1 \vee j < n$) that does not contain any word in \mathcal{L}_σ , there is no $s_c s_{c+1} \dots s_d$ in \mathcal{L}_σ with $c < i \leq d < j \vee i \leq c < j < d$.

Example 4 (pattern properties). A ‘yes’ in column N, O, E or S of the pattern part of Table 1 respectively indicates the NO-INFLEXION, the ONE-INFLEXION, the EXCLUDE-OUT-IN, or the SINGLE LETTER property.

- Ten out of the 19 reversible patterns of [3] have the NO-INFLEXION property. For instance, the pattern **DecTerrace** has the NO-INFLEXION property because it does not simultaneously contain the letters ‘<’ and ‘>’.
- Nine out of the 19 reversible patterns of [3] have the ONE-INFLEXION property. The pattern **Plain** has the ONE-INFLEXION property because it contains an occurrence of ‘<=*>’, but not an occurrence of ‘>=*<’.
- Eight out of the 19 reversible patterns of [3] have the EXCLUDE-OUT-IN property. For instance, the pattern **IncSeq** has the EXCLUDE-OUT-IN property because any subword w of an increasing sequence such that $w \notin \mathcal{L}_{\text{IncSeq}}$ cannot be the start or the end of an increasing sequence, since w is of the form ‘==*’, i.e. does not start or end with a ‘<’.
- **Dec**, **Inc** and **Steady** have the SINGLE LETTER property.

4 Sliding Time-Series Constraints

We introduce the sliding time-series constraint we consider.

Definition 8. Given a feature f , a regular expression σ , an integer $m > 1$, two variables low and up , and a sequence of variables $\mathcal{X} = x_1x_2 \dots x_n$ with $n \geq m$, the $\text{SLIDE_SUM_f_}\sigma(m, low, up, \mathcal{X})$ constraint holds iff

$$low = \min_{i \in [1, n-m+1]} r_i, \quad (1) \quad up = \max_{i \in [1, n-m+1]} r_i, \quad (2)$$

with $\text{SUM_f_}\sigma(r_i, x_{i,i+m-1})$, where r_i is called the contribution of the time-series constraint $\text{SUM_f_}\sigma$ in the window $[i, i+m-1]$.

Cond. (1), (resp. (2)), of Def. 8 enforces low (resp. up) to be the minimum (resp. maximum) of the sum of the feature values of feature f wrt all maximal occurrences of σ in each subsequence of m consecutive variables of sequence \mathcal{X} .

Example 5 (Continuation of Example (1)). Given the pattern **IncSeq** and the feature **surf**, $\text{SLIDE_SUM_SURF_INCSEQ}(10, 7, 15, 3133211222443122)$ is satisfied because the sum of the surfaces of the increasing sequences in the different sliding windows of size 10 is between 7 and 15 as shown in Example 1.

4.1 Computing the Contribution in a Window

In this section, we consider the patterns σ and σ^r which are the reverse of each other, a feature f , an integer sequence $x_1x_2\dots x_n$, and all windows $x_ix_{i+1}\dots x_{i+m-1}$ of size m (with $i \in [1, n - m + 1]$). We investigate how to evaluate directly from an equation the sum of the feature values of feature f of all pattern occurrences located in a window $[i, j = i + m - 1]$, assuming all the elements of the right-hand side of an equation have been previously calculated in time proportional to n . As we have several features and several patterns, we use three equations all derived from the same simple idea, for which we first present the intuition. Then we define sufficient properties of features and patterns that ensure the validity of each of the three equations (4), (5) and (6). At the end of this section, Table 4 provides an overview of the validity of each of the three equations according to properties of the patterns and features.

Intuition Assume we want to deal with the following simplified problem: given an integer sequence $x_1x_2\dots x_n$, compute for all subsequences of m consecutive positions the sum $t_{i,j} = \sum_{k \in [i,j]} x_k$ (with $j = i + m - 1$) of the corresponding elements in time $O(n)$. This can be done by first computing the partial sums $\sum_{c \in [1,k]} x_c$ (with $k \in [1, n]$), and $\sum_{c \in [k,n]} x_c$ (with $k \in [1, n]$) and by using the identity

$$t_{i,j} = \sum_{k \in [1,j]} x_k + \sum_{k \in [i,n]} x_k - \sum_{k \in [1,n]} x_k . \quad (3)$$

Equations (4), (5) and (6) present three alternative ways to compute $f_\sigma(x_{i,j})$ inspired by Equation (3).

$$f_\sigma(x_{i,j}) = f_\sigma(x_{1,j}) + f_{\sigma^r}(x_{n,i}) - f_\sigma(x_{1,n}) \quad (4)$$

$$f_\sigma(x_{i,j}) = \max(0, f_\sigma(x_{1,j}) + f_{\sigma^r}(x_{n,i}) - f_\sigma(x_{1,n})) \quad (5)$$

$$\begin{aligned} \text{if no } \sigma\text{-pattern in } x_{i,j} \text{ then } f_\sigma(x_{i,j}) &= 0 \\ \text{else } f_\sigma(x_{i,j}) &= f_\sigma(x_{1,j}) + f_{\sigma^r}(x_{n,i}) - f_\sigma(x_{1,n}) \end{aligned} \quad (6)$$

Depending on the properties of the pattern σ and of the feature f , we investigate the cases when Equations (4), (5) and (6) are valid.

Example 6. Consider the DecSeq pattern of Table 1, the sequence $w = 21110$, the window size $m = 2$, i.e. the four sliding windows 21, 11, 11 and 10.

- Equation (4) provides the incorrect **surf** feature value for two of the four sliding windows, namely values 3, -1 , -1 and 1 rather than the expected values 3, 0, 0 and 1. For the second window, shown in grey on the figure on the right, this is because there is a non-empty gap (shown in red) between the leftmost and rightmost decreasing sequences in w . Equation (5) $\frac{-5}{21110}$ gives the correct value since it cancels out the contribution of the gap. $\frac{-5}{+3+1}$
- While Equations (4) and (5) give the incorrect **min** feature value for two of the four sliding windows, namely values 1, 1, 1 and 0 rather than values 1, 0, 0 and 0, Equation (6) provides the correct values.

case	condition	illustration
(1)	$u < i$	
(2)	$\ell > j$	
(3)	$i \leq \ell \leq u \leq j$	
(4)	$\ell < i \leq u \leq j \wedge p(s_{i,u-1}) \in \mathcal{L}_\sigma$	
(5)	$\ell < i \leq u < j \wedge p(s_{i,u-1}) \notin \mathcal{L}_\sigma$	
(6)	$i \leq \ell \leq j < u \wedge s(s_{\ell,j-1}) \in \mathcal{L}_\sigma$	
(7)	$i < \ell \leq j < u \wedge s(s_{\ell,j-1}) \notin \mathcal{L}_\sigma$	
(8)	$(\ell \leq i \leq j \leq u) \wedge (\ell \neq i \vee j \neq u)$	

Table 2: Positioning an occurrence of a pattern wrt a window; within cases (4) and (6) the non-empty words $p(s_{i,u-1})$ and $s(s_{\ell,j-1})$ are shown in light grey.

Case Analysis Consider a sequence $x_1x_2 \dots x_n$, a window $[i, j]$, and a maximal occurrence of pattern o whose signature is $s_\ell s_{\ell+1} \dots s_{u-1}$ (with $1 \leq \ell \leq u \leq n$). Table 2 provides eight cases summarising all the possible positioning of $x_{\ell,u}$ wrt $[i, j]$, where $p(s_{i,u-1})$ (resp. $s(s_{\ell,j-1})$) denotes the longest prefix $s_i s_{i+1} \dots s_{\alpha-1}$ of $s_i s_{i+1} \dots s_{u-1}$ (resp. the longest suffix $s_\beta s_{\beta+1} \dots s_{j-1}$ of $s_\ell s_{\ell+1} \dots s_{j-1}$) in \mathcal{L}_σ if such word exists, the empty word otherwise. For cases (1–7) of Table 2, columns $f_\sigma(x_{1,j})$ (resp. $f_{\sigma^r}(x_{n,i})$) and $f_\sigma(x_{1,n})$ of Table 3 provide the feature value of the σ -pattern occurrence o (resp. σ^r -pattern occurrence o^r) wrt $x_1x_2 \dots x_j$ (resp. $x_nx_{n-1} \dots x_i$) and $x_1x_2 \dots x_n$; the last three columns give the contribution of o in the right-hand side of Equations (4), (5), (6). These contributions agree with the positioning of $x_{\ell,u}$ wrt $[i, j]$, except for the three grey cells, which only work for non-negative feature values. Case (8) of Table 2 corresponds to a maximal occurrence of pattern o whose signature starts before i and ends after j . To study Case (8), the next section classifies a pattern wrt a window.

case	$f_\sigma(x_{1,j})$	$f_{\sigma^r}(x_{n,i})$	$f_\sigma(x_{1,n})$	Eq. (4)	Eq. (5)	Eq. (6)
(1)	$f_\sigma(x_{\ell,u})$	0	$f_\sigma(x_{\ell,u})$	0	0	0
(2)	0	$f_{\sigma^r}(x_{u,\ell})$	$f_\sigma(x_{\ell,u})$	0	0	0
(3)	$f_\sigma(x_{\ell,u})$	$f_{\sigma^r}(x_{u,\ell})$	$f_\sigma(x_{\ell,u})$	$f_{\sigma^r}(x_{u,\ell})$	$\max(0, f_{\sigma^r}(x_{u,\ell}))$	$f_{\sigma^r}(x_{u,\ell})$
(4)	$f_\sigma(x_{\ell,u})$	$f_{\sigma^r}(x_{\alpha,i})$	$f_\sigma(x_{\ell,u})$	$f_{\sigma^r}(x_{\alpha,i})$	$\max(0, f_{\sigma^r}(x_{\alpha,i}))$	$f_{\sigma^r}(x_{\alpha,i})$
(5)	$f_\sigma(x_{\ell,u})$	0	$f_\sigma(x_{\ell,u})$	0	0	0
(6)	$f_\sigma(x_{\beta,j})$	$f_{\sigma^r}(x_{u,\ell})$	$f_\sigma(x_{\ell,u})$	$f_\sigma(x_{\beta,j})$	$\max(0, f_\sigma(x_{\beta,j}))$	$f_\sigma(x_{\beta,j})$
(7)	0	$f_{\sigma^r}(x_{u,\ell})$	$f_\sigma(x_{\ell,u})$	0	0	0

Table 3: [COLUMNS 2 TO 4] values of $f_\sigma(x_{1,j})$, $f_{\sigma^r}(x_{n,i})$ and $f_\sigma(x_{1,n})$ wrt cases (1–7) of Table 2; [COLUMNS 5 TO 7] contribution of an occurrence of σ in a window wrt the right-hand side of Equations (4), (5) and (6).

A Systematic Classification of Patterns wrt Windows

Definition 9. [type of a word wrt a pattern] *Given a pattern σ , the type of a proper factor $w = w_1w_2\dots w_k$ of a word in \mathcal{L}_σ wrt σ is defined by five mutually incompatible conditions:*

- out if $\nexists c, d : 1 \leq c \leq d \leq k \wedge w_cw_{c+1}\dots w_d \in \mathcal{L}_\sigma$
- fac if $\begin{cases} \exists c, d : 1 \leq c \leq d \leq k \wedge w_cw_{c+1}\dots w_d \in \mathcal{L}_\sigma \\ \nexists d : 1 \leq d \leq k \wedge w_1w_2\dots w_d \in \mathcal{L}_\sigma \\ \nexists c : 1 \leq c \leq k \wedge w_cw_{c+1}\dots w_k \in \mathcal{L}_\sigma \end{cases}$
- pre if $\begin{cases} \exists d : 1 \leq d \leq k \wedge w_1w_2\dots w_d \in \mathcal{L}_\sigma \\ \nexists c : 1 \leq c \leq k \wedge w_cw_{c+1}\dots w_k \in \mathcal{L}_\sigma \end{cases}$
- suf if $\begin{cases} \exists c : 1 \leq c \leq k \wedge w_cw_{c+1}\dots w_k \in \mathcal{L}_\sigma \\ \nexists d : 1 \leq d \leq k \wedge w_1w_2\dots w_d \in \mathcal{L}_\sigma \end{cases}$
- in if $\begin{cases} \exists d : 1 \leq d \leq k \wedge w_1w_2\dots w_d \in \mathcal{L}_\sigma \\ \exists c : 1 \leq c \leq k \wedge w_cw_{c+1}\dots w_k \in \mathcal{L}_\sigma \end{cases}$

In Definition 9, “fac”, “pre” and “suf” convey the idea of “factor”, “prefix” and “suffix”. Note that a word with the “in” type wrt a convex pattern σ is in \mathcal{L}_σ . The languages associated with the five mutually incompatible conditions of Definition 9 are defined as $\mathcal{L}_{\text{out}} = \Sigma^+ \setminus (\Sigma^* \mathcal{L}_\sigma \Sigma^*)$, $\mathcal{L}_{\text{fac}} = \Sigma^+ \mathcal{L}_\sigma \Sigma^+ \cap \Sigma^* \setminus (\mathcal{L}_\sigma \Sigma^+) \cap \Sigma^* \setminus (\Sigma^+ \mathcal{L}_\sigma) \cap \Sigma^* \setminus \mathcal{L}_\sigma$, $\mathcal{L}_{\text{pre}} = \mathcal{L}_\sigma \Sigma^+ \cap \Sigma^* \setminus (\Sigma^+ \mathcal{L}_\sigma) \cap \Sigma^* \setminus \mathcal{L}_\sigma$, $\mathcal{L}_{\text{suf}} = \Sigma^+ \mathcal{L}_\sigma \cap \Sigma^* \setminus (\mathcal{L}_\sigma \Sigma^+) \cap \Sigma^* \setminus \mathcal{L}_\sigma$, and $\mathcal{L}_{\text{in}} = \mathcal{L}_\sigma \Sigma^* \cap \Sigma^* \mathcal{L}_\sigma$. Note that because of our hypothesis that \mathcal{L}_σ does not contain the empty word, the languages \mathcal{L}_{out} , \mathcal{L}_{fac} , \mathcal{L}_{pre} , \mathcal{L}_{suf} and \mathcal{L}_{in} do not contain the empty word.

Definition 10. [type and signature of a word wrt one of its proper factors and wrt a pattern] *Given a pattern σ , consider a word $w = w_1w_2\dots w_k$ of \mathcal{L}_σ , and one of its proper factors $v = w_iw_{i+1}\dots w_j$. The type of w wrt v and σ is defined by $\langle t_1, t_2, t_3 \rangle$ where t_1 , t_2 and t_3 are respectively the type of words $w_1w_2\dots w_j$, $w_iw_{i+1}\dots w_j$ and $w_iw_{i+1}\dots w_k$ wrt pattern σ as defined by Definition 9. The signature of w wrt v and σ is defined by $\langle \text{sig}_1, \text{sig}_2, \text{sig}_3 \rangle$, where $\text{sig}_c = 1$ if $t_c = \text{out}$ then 1 else 0 (with $c \in [1, 3]$).*

Theorem 1. [map of feasible types wrt any pattern] *Of the 125 possible types of Definition 10, only 61 triples shown in Figure 1 are feasible.*

Proof. For each triple of Figure 1, Appendix A provides a witness pattern which generates such triple. We now prove that the missing triples cannot be obtained from any pattern.

- ① $\langle \text{out}, \neq \text{out}, - \rangle$ (resp. $\langle -, \neq \text{out}, \text{out} \rangle$) is not feasible since an “out” in $v = w_1w_2\dots w_j$ (resp. $w_iw_{i+1}\dots w_k$) would imply an “out” in any subsequence of v , namely in $w_iw_{i+1}\dots w_j$, a contradiction.
- ② $\langle \text{fac}, \text{suf}, - \rangle$ (resp. $\langle -, \text{pre}, \text{fac} \rangle$) is not feasible since a “suf” (resp. “pre”) in $w_iw_{i+1}\dots w_j$ would imply a “suf” (resp. “pre”) or an “in” in $w_1w_2\dots w_j$ (resp. $w_iw_{i+1}\dots w_k$), a contradiction.

- ③ $\langle \text{fac}, \text{in}, - \rangle$ (resp. $\langle -, \text{in}, \text{fac} \rangle$) is not feasible since a “in” in $w_i w_{i+1} \dots w_j$ would imply a “suf” (resp. “pre”) or an “in” in $w_1 w_2 \dots w_j$ (resp. $w_i w_{i+1} \dots w_k$), a contradiction.
- ④ $\langle \text{pre}, \text{suf}, - \rangle$ (resp. $\langle -, \text{pre}, \text{suf} \rangle$) is not feasible since a “suf” (resp. “pre”) in $w_i w_{i+1} \dots w_j$ and a “pre” (resp. “suf”) in $v = w_1 w_2 \dots w_j$ (resp. $v = w_i w_{i+1} \dots w_k$) would imply an “in” in v , a contradiction.
- ⑤ $\langle \text{pre}, \text{in}, - \rangle$ (resp. $\langle -, \text{in}, \text{suf} \rangle$) is not feasible since an “in” in $w_i w_{i+1} \dots w_j$ and a “pre” (resp. “suf”) in $v = w_1 w_2 \dots w_j$ (resp. $v = w_i w_{i+1} \dots w_k$) would imply an “in” in v , a contradiction. \square

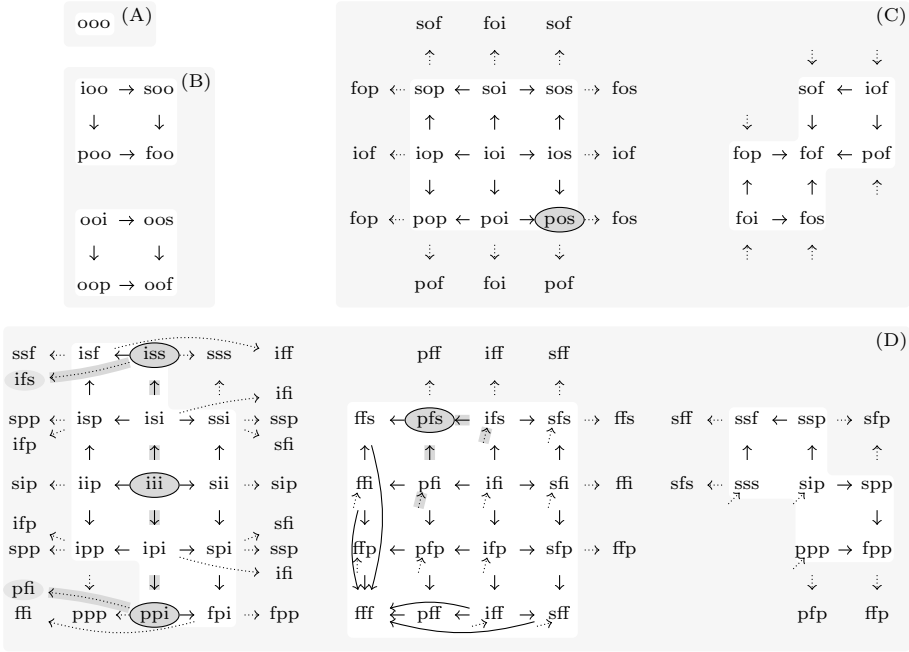

Fig. 1: Map of the 61 feasible types where Parts (A), (B), (C) and (D) resp. correspond to triples with three “out”, two “out”, one “out” and no “out”, where o, i, p, s, f resp. are abbreviations for “out”, “in”, “pre”, “suf”, “fac”; there is an arc from a triple t_1 to a triple t_2 iff (1) t_1 and t_2 have the same signature, (2) t_1 and t_2 differ exactly from one position, (3) t_1 is lexicographically less than t_2 assuming $i \prec p$, $i \prec s$, $p \prec f$ and $s \prec f$; ellipses denote the types of the DecSeq pattern as described in Example 7.

Notation In the context of Definition 10, when $w_1 w_2 \dots w_j$ is of type pre or in, i.e. it contains a maximal occurrence of a word x in \mathcal{L}_σ starting at index 1, ψ denotes the index of the last letter of x . Similarly, when $w_i w_{i+1} \dots w_k$ is of type suf or in, i.e. it contains a maximal occurrence of a word y in \mathcal{L}_σ ending

at index k , λ denotes the index of the first letter of y .

The number of triples being important, 61 in our case, we reduce the number of cases to be considered in our proofs, by introducing Definition 11 which groups a certain number of triples in the same class representing the weakest hypothesis associated with the different triples in this class. Consider the (finite) set \mathcal{S} of triples associated with the words of \mathcal{L}_σ wrt their proper factors. We partition the set \mathcal{S} into subsets where all triples of the same subset have the same signature. Then, we generalise all the triples that belong to the same subset to a unique representative using the following definition.

Definition 11. [generalising a set of triples] *Given a pattern σ , consider the set of triples \mathcal{S} consisting of all types of the words of \mathcal{L}_σ wrt their proper factors and wrt σ that have the same signature. Let \mathcal{S}_c (with $c \in [1, 3]$) denote the set of all the c^{th} components of the triples of \mathcal{S} . The set \mathcal{S} is represented by a single representative triple $\mathcal{R}_\mathcal{S} = \langle r_1, r_2, r_3 \rangle$ where r_c , with $c \in [1, 3]$, is defined by*

- $\mathcal{S}_c = \{\text{out}\}$ $\Rightarrow r_c = \text{OUT}$
- $\text{fac} \in \mathcal{S}_c$ $\Rightarrow r_c = \text{FAC}$
- $\text{pre} \in \mathcal{S}_c \wedge \text{suf} \notin \mathcal{S}_c \wedge \text{fac} \notin \mathcal{S}_c$ $\Rightarrow r_c = \text{PRE}$
- $\text{suf} \in \mathcal{S}_c \wedge \text{pre} \notin \mathcal{S}_c \wedge \text{fac} \notin \mathcal{S}_c$ $\Rightarrow r_c = \text{SUF}$
- $\text{pre} \in \mathcal{S}_c \wedge \text{suf} \in \mathcal{S}_c \wedge \text{fac} \notin \mathcal{S}_c$ $\Rightarrow r_c = \text{PS}$
- $\text{in} \in \mathcal{S}_c \wedge \text{pre} \notin \mathcal{S}_c \wedge \text{suf} \notin \mathcal{S}_c \wedge \text{fac} \notin \mathcal{S}_c$ $\Rightarrow r_c = \text{IN}$

Definition 12. [pattern class] *Given a pattern σ , the set of representative triples of σ is called the class of σ .*

Example 7. The set \mathcal{S} of possible types associated with the `DecSeq` pattern $\langle \langle \rangle \langle \rangle \langle \rangle \langle \rangle \rangle^* \langle \rangle \langle \rangle \langle \rangle \langle \rangle \langle \rangle$ is equal to the union of two subsets $\mathcal{S}_1 = \{\langle \text{pre}, \text{fac}, \text{suf} \rangle, \langle \text{pre}, \text{pre}, \text{in} \rangle, \langle \text{in}, \text{suf}, \text{suf} \rangle, \langle \text{in}, \text{in}, \text{in} \rangle\}$ and $\mathcal{S}_2 = \{\langle \text{pre}, \text{out}, \text{suf} \rangle\}$, where each subset corresponds to triples for which all ‘‘out’’ are located in the same positions, see the five ellipses in Parts (D) and (C) of Figure 1. Part (A) of Figure 2 gives for each element of \mathcal{S}_1 and \mathcal{S}_2 a corresponding example of a word and a proper factor. The sets \mathcal{S}_1 and \mathcal{S}_2 are respectively represented by the triples $\langle \text{PRE}, \text{FAC}, \text{SUF} \rangle$ and $\langle \text{PRE}, \text{OUT}, \text{SUF} \rangle$ as shown in Part (B) of Figure 2. Finally, Figure 3 provides the representative triples for all reversible and convex patterns of Table 1, which do not have the single letter property.

Finding all the representatives of a pattern To generate all the representatives of a pattern σ , (i) we first generate all potential word types wrt σ , and (ii) we then use Definition 11. For each of the 61 potential word type $\langle t_1, t_2, t_3 \rangle$ with $t_i \in \{\text{out}, \text{fac}, \text{pre}, \text{suf}, \text{in}\}$ depicted in Figure 1, we describe a systematic method to check whether there exists or not a word $w = w_1 w_2 \dots w_k$ of \mathcal{L}_σ whose type is $\langle t_1, t_2, t_3 \rangle$. For this purpose we define the language of $\langle t_1, t_2, t_3 \rangle$ wrt to σ and check whether it is empty or not. Since we need the prefix of w associated with t_1 to overlap the suffix of w associated with t_3 , we first introduce the notion of *shuffle language*.

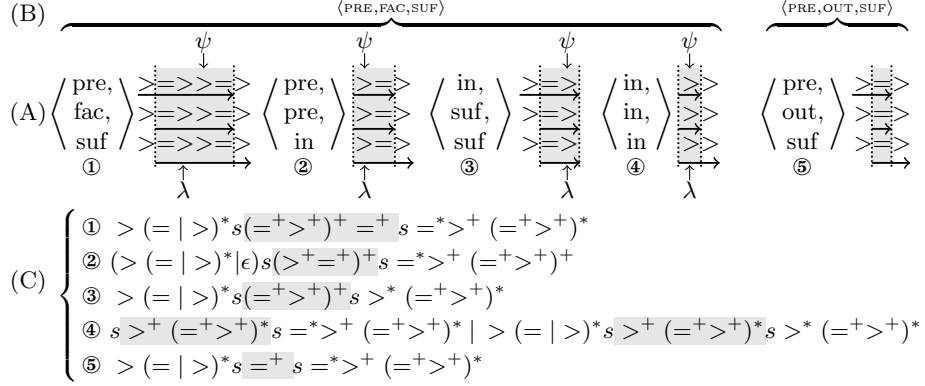

Fig. 2: (A) Set of possible types of words wrt their proper factors of the DecSeq pattern with the corresponding examples of word w and proper factor (in grey) where ψ (resp. λ) denotes the end (resp. start) of a maximal word in $\mathcal{L}_{\text{DecSeq}}$ starting at the first position (resp. ending at the last position) of w , (B) corresponding set of representative triples, and (C) languages of the types of words $\textcircled{1}$, $\textcircled{2}$, $\textcircled{3}$, $\textcircled{4}$, $\textcircled{5}$ as computed from Equation (7) of Theorem 2.

Definition 13. [shuffle language] *Given a regular language \mathcal{L} over an input alphabet Σ , and a possibly new input letter s , i.e. a letter that does not necessarily belong to Σ , the shuffle language of \mathcal{L} wrt s , denoted $\text{shuffle}(\mathcal{L}, s)$, is defined by all words w over the alphabet $\Sigma \cup \{s\}$ such that*

- i) w contains at least one occurrence of the letter s ,
- ii) if we remove one single occurrence of the letter s from w then the resulting word belongs to \mathcal{L} .

Theorem 2. [language of a word type] *Given a pattern σ and one of its potential word types $\langle t_1, t_2, t_3 \rangle$, the language associated with $\langle t_1, t_2, t_3 \rangle$ is defined by*

$$\bigcap \left(\begin{array}{l} \text{shuffle}(\text{shuffle}(\mathcal{L}_\sigma, s), s) \\ \text{shuffle}(\mathcal{L}_{t_1}, s) s \Sigma^* \\ \Sigma^* s \mathcal{L}_{t_2} s \Sigma^+ | \Sigma^+ s \mathcal{L}_{t_2} s \Sigma^* \\ \Sigma^* s \text{shuffle}(\mathcal{L}_{t_3}, s) \end{array} \right) \quad (7)$$

Proof. The four sub-expressions on the right-hand side of (7) respectively correspond to a word of \mathcal{L}_σ to which two occurrences of s are inserted, and in three ways of decomposing it wrt its prefix, to its window, and to its suffix. The letter s is used to “synchronise” these decompositions, i.e. to enforce a non-empty intersection between the prefix and the suffix. Since \mathcal{L}_{t_2} does not contain the empty word, the two occurrences of s delimit a non-empty window. \square

Example 8 (Continuation of Example (7)). Part (C) of Figure 2 gives the languages of the types of words $\langle \text{pre, fac, suf} \rangle$, $\langle \text{pre, pre, in} \rangle$, $\langle \text{in, suf, suf} \rangle$, $\langle \text{in, in, in} \rangle$,

and $\langle \text{pre}, \text{out}, \text{suf} \rangle$ for the **DecSeq** pattern, as defined by Theorem 2. Note that all other triples lead to the empty language.

Evaluating whether the language associated with a regular expression is empty or not (e.g. Expression (7)) is done by (i) converting all its operator instances (e.g. union, intersection, concatenation, Kleene star, shuffle, ...) to deterministic finite automata, by (ii) evaluating the corresponding sequence of operations on finite automata, and by (iii) checking whether the resulting minimised automaton has at least one accepting state or not. Following this methodology, Appendix C gives the corresponding programs which compute the representatives and the properties of a pattern. We now show how to generate a finite automaton for the shuffle operator that we previously introduce.

- [shuffle] From the deterministic and minimised automaton $A_{\mathcal{L}}$ associated with \mathcal{L} , one can build the automaton $A_{\text{shuffle}(\mathcal{L}, s)}$ associated with the language $\text{shuffle}(\mathcal{L}, s)$ by (i) duplicating all states of $A_{\mathcal{L}}$ and make them non-initial, (ii) make all states of $A_{\mathcal{L}}$ non-accepting, (iii) add a transition labelled by s from each state to its duplicated state.

Establishing the properties of a pattern We now describe how to systematically find the properties of a pattern σ . We use $\mathcal{L}_{\sigma}^{ss}$ (resp. $\mathcal{L}_{\sigma}^{sss}$) as a shortcut for $\text{shuffle}(\text{shuffle}(\text{shuffle}(\text{shuffle}(\mathcal{L}_{\sigma}, s), s), s), s)$ (resp. $\text{shuffle}(\text{shuffle}(\mathcal{L}_{\sigma}, s), s)$).

- A pattern σ has the CONVEXITY property iff

$$\cap \left(\begin{array}{c} \mathcal{L}_{\sigma}^{ss} \\ \Sigma^* s \mathcal{L}_{\sigma} \Sigma^* \mathcal{L}_{\sigma} s \Sigma^* \\ \Sigma^* s (\Sigma^+ \setminus \mathcal{L}_{\sigma}) s \Sigma^* \end{array} \right) \cup \cap \left(\begin{array}{c} \mathcal{L}_{\sigma}^{ssss} \\ \Sigma^* s \text{shuffle}(\mathcal{L}_{\sigma}, s) s \Sigma^+ s \Sigma^* \\ \Sigma^* s \Sigma^+ s \text{shuffle}(\mathcal{L}_{\sigma}, s) s \Sigma^* \\ \Sigma^* s \text{shuffle}(\text{shuffle}(\Sigma^+ \setminus \mathcal{L}_{\sigma}, s), s) s \Sigma^* \end{array} \right) = \emptyset \quad (8)$$

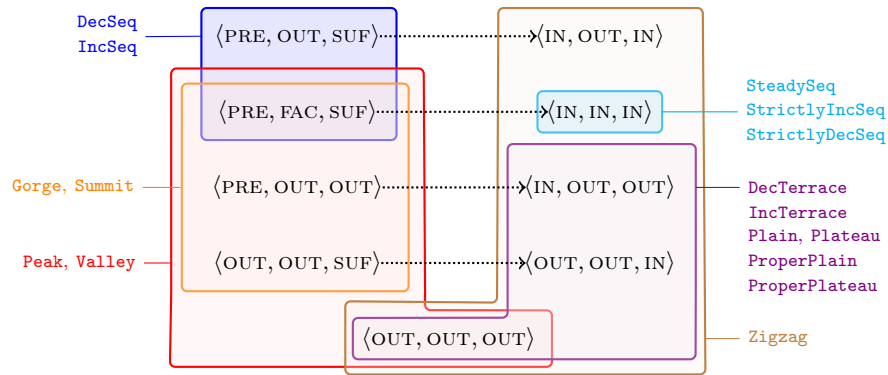

Fig. 3: Pattern classes, where each class corresponds to a set of representative triples (an arrow from a triple ① to a triple ② means that ① generalises ②)

- A pattern σ has the NO-INFLEXION property iff

$$(\mathcal{L}_\sigma \cap \Sigma^* < \Sigma^* > \Sigma^*) \cup (\mathcal{L}_\sigma \cap \Sigma^* > \Sigma^* < \Sigma^*) = \emptyset \quad (9)$$

- A pattern σ has the ONE-INFLEXION property iff

$$\mathcal{L}_\sigma \setminus \mathcal{L}_{(<|=)* <=* > (>|=)* |(>|=)* >=* <(<|=)*} = \emptyset \quad (10)$$

- A pattern σ has the EXCLUDE-OUT-IN property iff

$$\cap \left(\begin{array}{c} \mathcal{L}_\sigma^{ssss} \\ \Sigma^* s \Sigma^+ s \text{shuffle}(\Sigma^+ \setminus (\Sigma^* \mathcal{L}_\sigma \Sigma^*), s) s \Sigma^* \\ \Sigma^* s \text{shuffle}(\mathcal{L}_\sigma, s) s \Sigma^* s \Sigma^* \\ \Sigma^* s \Sigma^+ s \Sigma^+ s \Sigma^* s \Sigma^* \end{array} \right) \cup \cap \left(\begin{array}{c} \mathcal{L}_\sigma^{ssss} \\ \Sigma^* s \text{shuffle}(\Sigma^+ \setminus (\Sigma^* \mathcal{L}_\sigma \Sigma^*), s) s \Sigma^+ s \Sigma^* \\ \Sigma^* s \Sigma^* s \text{shuffle}(\mathcal{L}_\sigma, s) s \Sigma^* \\ \Sigma^* s \Sigma^* s \Sigma^+ s \Sigma^+ s \Sigma^* \end{array} \right) = \emptyset \quad (11)$$

- A pattern σ has the SINGLE LETTER property iff

$$\mathcal{L}_\sigma \setminus \mathcal{L}_{<|=|>} = \emptyset \quad (12)$$

As the constructions used in (8), (9), (10), (11) and (12) are similar to the one used in Theorem 2, they are not detailed.

Proof of Equations Based on Pattern and Feature Properties. In this section we study the properties of patterns and features that ensure the validity of Equations (4), (5) and (6). While pattern properties were already introduced in Sections 3 and 4.1, we first present some feature properties. Second, we focus on the validity domain of Equation (4), and finally, based on these results, we derive the properties of the patterns and features for Equations (5) and (6). From now on we focus on commutative features, as well as reversible and convex patterns, which do not have the SINGLE LETTER property.

Feature Properties All definitions of this section, i.e. Definitions 14 to 19, as well as all theorems of this section, i.e. Theorems 3 to 9, consider (i) a reversible and convex pattern $\sigma = \langle \mathcal{L}_\sigma, b_\sigma, a_\sigma \rangle$, (ii) a sequence of variables $\mathcal{X} = x_1 x_2 \dots x_n$, (iii) an extended σ -pattern occurrence in $[1, n]$ given by $o = \langle x_\ell x_{\ell+1} \dots x_u \rangle$ with $1 \leq \ell \leq u \leq n$, and (iv) a commutative feature f applied to o .

We first present four feature properties that only depend on the feature f . We then introduce two additional feature properties that depend on both the feature f and the pattern σ . Finally, Part (A) of Figure 4 summarises the feature properties of each of the features defined in the time-series catalogue [3].

Definition 14. A feature f has the SUM DECOMPOSITION property if $f_\sigma(x_{\ell,u})$

can be expressed as $\sum_{t=\ell+b_\sigma}^{u-a_\sigma} h(x_t)$, where $h(x_t)$ is a function.

E.g., when $f = \text{width}$, $h(x_t) = 1$ and the value returned by the application of f to the extended σ -pattern occurrence o is $u - \ell - b_\sigma - a_\sigma + 1$.

Definition 15. A feature f has the **SAME VALUE** property if $f_\sigma(x_{\ell,u}) = f_\sigma(x_{i,j})$ for all i, j ($\ell \leq i \leq j \leq u$) such that the sequence $x_{i,j}$ alone is an extended σ -pattern occurrence.

E.g., when $f = \text{one}$ and $x_{i,j}$ is an extended σ -pattern, $f_\sigma(x_{\ell,u}) = f_\sigma(x_{i,j}) = 1$.

Definition 16. A feature f has the **SINGLE POSITION** property if $f_\sigma(x_{\ell,u})$ can be expressed as $h(x_t)$ with $x_t \in \{x_{\ell+b_\sigma}, x_{\ell+b_\sigma+1}, \dots, x_{u-a_\sigma}\}$.

E.g., when $f = \text{max}$, $h(x_t) = x_t$ and $f_\sigma(x_{\ell,u})$ is the maximum of the variables in $x_{\ell+b_\sigma, u-a_\sigma}$.

Definition 17. A feature f has the **POSITIVE** property if $f_\sigma(x_{i,j}) \geq 0 \forall i, j$, such that $1 \leq i \leq j \leq n$.

Definition 18. A feature f and a pattern σ have the **SINGLE POSITION NO-INFLEXION** property if (i) f has the **SINGLE POSITION** property, (ii) σ has the **NO-INFLEXION** property and either (iii.a) for all extended σ -pattern occurrences $x_{p,q}$ wrt $x_{p,q}$ (with $\ell \leq p \leq q \leq u$) $f_\sigma(x_{p,q}) = h(x_{p+b_\sigma})$, or (iii.b) for all extended σ -pattern occurrences $x_{p,q}$ wrt $x_{p,q}$ (with $\ell \leq p \leq q \leq u$) $f_\sigma(x_{p,q}) = h(x_{q-a_\sigma})$.

E.g., the pair $\sigma = \text{DecSeq}$, $f = \text{min}$, has the **SINGLE POSITION NO-INFLEXION** property since $f_\sigma(x_{\ell,u}) = x_{q-a_\sigma}$, where q is the end of the extended σ -pattern occurrence in $x_{\ell,u}$.

Definition 19. A feature f and a pattern σ have the **SINGLE POSITION INFLEXION** property if (i) f has the **SINGLE POSITION** property, (ii) σ has the **ONE-INFLEXION** property and (iii) $f_\sigma(x_{\ell,u})$ is computed from the position of the only inflexion of σ .

E.g., the pair $\sigma = \text{Gorge}$, $f = \text{min}$ has the **SINGLE POSITION INFLEXION** property since the value of $f_\sigma(x_{\ell,u})$ corresponds to the only inflexion of the extended σ -pattern occurrence. But the pair $\sigma = \text{Gorge}$, $f = \text{max}$, does not have the **SINGLE POSITION INFLEXION** property since $f_\sigma(x_{\ell,u})$ corresponds to one of the two extremities of the gorge.

The next two sections define sufficient conditions where (i) Equation (4) and (ii) Equations (5) and (6) can be used to compute the value of $f_\sigma(x_{i,j})$ wrt a pattern σ , depending on the representatives of a pattern. Part (B) of Figure 4 summarises all the theorems introduced in these two sections wrt the representatives of Figure 3.

Remark 1. Wlog, while doing the proof of such conditions we proceed as follows:

- When the representatives $\langle \text{PRE}, \text{FAC}, \text{SUF} \rangle$ and $\langle \text{IN}, \text{IN}, \text{IN} \rangle$ are both present, only $\langle \text{PRE}, \text{FAC}, \text{SUF} \rangle$ is considered, since for $\langle \text{IN}, \text{IN}, \text{IN} \rangle$ $\lambda = i$ and $\psi = j$ is a special case of $\langle \text{PRE}, \text{FAC}, \text{SUF} \rangle$.
- Similarly, when the representatives $\langle \text{PRE}, \text{OUT}, \text{OUT} \rangle$ and $\langle \text{IN}, \text{OUT}, \text{OUT} \rangle$ (resp. $\langle \text{OUT}, \text{OUT}, \text{SUF} \rangle$ and $\langle \text{OUT}, \text{OUT}, \text{IN} \rangle$) both intervene in a proof, only $\langle \text{PRE}, \text{OUT}, \text{OUT} \rangle$ (resp. $\langle \text{OUT}, \text{OUT}, \text{SUF} \rangle$) is considered, as $\psi = j$ (resp. $\lambda = i$).

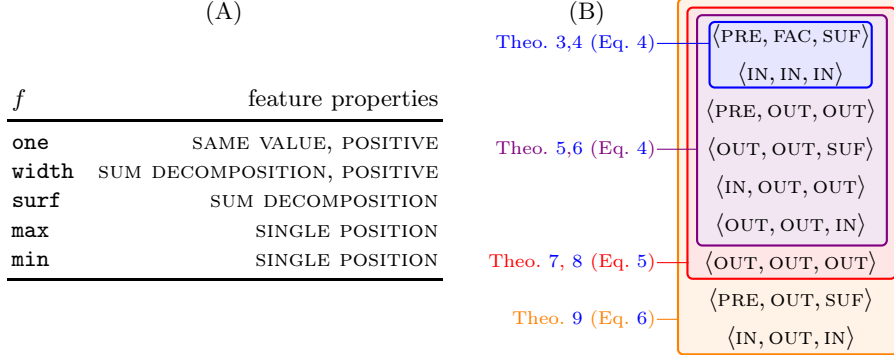

Fig. 4: (A) Properties of the features defined in Table 1 and used in [3], (B) theorems coverage for the different representatives of Figure 3.

- When $\langle \text{IN}, \text{OUT}, \text{OUT} \rangle$ and $\langle \text{OUT}, \text{OUT}, \text{IN} \rangle$ (resp. $\langle \text{PRE}, \text{OUT}, \text{OUT} \rangle$ and $\langle \text{OUT}, \text{OUT}, \text{SUF} \rangle$) both intervene in a proof, only $\langle \text{IN}, \text{OUT}, \text{OUT} \rangle$ (resp. $\langle \text{PRE}, \text{OUT}, \text{OUT} \rangle$) is considered, as the representative $\langle \text{OUT}, \text{OUT}, \text{IN} \rangle$ (resp. $\langle \text{OUT}, \text{OUT}, \text{SUF} \rangle$) is symmetric.

Sufficient Conditions for the Validity of Equation (4)

Theorem 3. Consider a pattern σ whose class has a non-empty intersection with the set of representatives $\mathcal{S} = \{\langle \text{PRE}, \text{FAC}, \text{SUF} \rangle, \langle \text{IN}, \text{IN}, \text{IN} \rangle\}$. Equation (4) can be used to obtain $f_\sigma(x_{i,j})$ for a sequence $x_{1,n}$ wrt a window $[i, j]$ whose type is in \mathcal{S} , assuming that feature f has the SUM DECOMPOSITION property.

Proof. From Remark 1, we just consider $\langle \text{PRE}, \text{FAC}, \text{SUF} \rangle$. We first establish properties between the maximum words associated with PRE, FAC and SUF.

- From the CONVEXITY property, the signature of the words $x_{\ell,j}$, $x_{i,j}$ and $x_{i,u}$ respectively contain at most one maximum word in \mathcal{L}_σ . Because of PRE, FAC and SUF, the signature of the words $x_{\ell,j}$, $x_{i,j}$ and $x_{i,u}$ respectively contain at least one word in \mathcal{L}_σ . Consequently, the signatures of the words $x_{\ell,j}$, $x_{i,j}$ and $x_{i,u}$ contain one single maximum word in \mathcal{L}_σ , respectively denoted by w_{PRE} , w_{FAC} and w_{SUF} .
- Because the words w_{PRE} and w_{FAC} must not end after position j , and from the CONVEXITY property, w_{PRE} and w_{FAC} end in the same position ψ .
- Because the words w_{SUF} and w_{FAC} must not start before position i , and from the CONVEXITY property, w_{SUF} and w_{FAC} start at the same position λ .
- Because the word w_{FAC} starts at position λ and ends at position ψ we have that $\lambda \leq \psi$.

Since f has the SUM DECOMPOSITION property, by using the function h of Definition 14, Equation (4) can be rewritten as:

$$\begin{array}{c}
\overbrace{1 \ \ell \ i \ \lambda \ \psi \ j \ u \ n}^{f_{\sigma^r}(x_{n,i})=f_{\sigma^r}(x_{u,i})} \\
\underbrace{1 \ \ell \ i \ \lambda \ \psi \ j \ u \ n}_{f_{\sigma}(x_{1,j})=f_{\sigma}(x_{\ell,j})}
\end{array}
f_{\sigma}(x_{i,j}) = \underbrace{\sum_{t=\ell+b_{\sigma}}^{\psi-a_{\sigma}} h(x_t)}_{f_{\sigma}(x_{1,j})} + \underbrace{\sum_{t=\lambda+a_{\sigma^r}}^{u-b_{\sigma^r}} h(x_t)}_{f_{\sigma^r}(x_{n,i})} - \underbrace{\sum_{t=\ell+b_{\sigma}}^{u-a_{\sigma}} h(x_t)}_{f_{\sigma}(x_{1,n})} \quad (13)$$

By using the fact that the pattern σ is reversible (i.e. $a_{\sigma^r} = b_{\sigma}$ and $b_{\sigma^r} = a_{\sigma}$) in the second term of Equation (13), by expanding the terms $f_{\sigma^r}(x_{n,i})$ and $f_{\sigma}(x_{1,n})$ we obtain:

$$\begin{array}{c}
\sum_{t=\ell+b_{\sigma}}^{\psi-a_{\sigma}} h(x_t) + \sum_{t=\lambda+b_{\sigma}}^{\psi-a_{\sigma}} h(x_t) + \sum_{t=\psi-a_{\sigma}+1}^{u-a_{\sigma}} h(x_t) - \sum_{t=\ell+b_{\sigma}}^{\psi-a_{\sigma}} h(x_t) - \sum_{t=\psi-a_{\sigma}+1}^{u-a_{\sigma}} h(x_t) = \\
\underbrace{\sum_{t=\ell+b_{\sigma}}^{\psi-a_{\sigma}} h(x_t)}_{f_{\sigma}(x_{1,j})} + \underbrace{\sum_{t=\lambda+b_{\sigma}}^{\psi-a_{\sigma}} h(x_t) + \sum_{t=\psi-a_{\sigma}+1}^{u-a_{\sigma}} h(x_t)}_{f_{\sigma^r}(x_{n,i})} - \underbrace{\sum_{t=\ell+b_{\sigma}}^{\psi-a_{\sigma}} h(x_t) + \sum_{t=\psi-a_{\sigma}+1}^{u-a_{\sigma}} h(x_t)}_{f_{\sigma}(x_{1,n})} = \\
\sum_{t=\lambda+b_{\sigma}}^{\psi-a_{\sigma}} h(x_t) = f_{\sigma}(x_{i,j}).
\end{array}$$

Hence, Equation (4) holds. \square

Theorem 4. Consider a pattern σ whose class has a non-empty intersection with the set of representatives $\mathcal{S} = \{\langle \text{PRE}, \text{FAC}, \text{SUF} \rangle, \langle \text{IN}, \text{IN}, \text{IN} \rangle\}$. Equation (4) can be used to obtain $f_{\sigma}(x_{i,j})$ for a sequence $x_{1,n}$ wrt window $[i, j]$ whose type is in \mathcal{S} , assuming that f, σ has the SINGLE POSITION NO-INFLEXION property.

Proof. Because of Remark 1 we only consider the representative $\langle \text{PRE}, \text{FAC}, \text{SUF} \rangle$. In this context, for the reason quoted in the first part of the proof of Theorem 3, the signature of $x_{\ell,j}$ contains a maximum word in \mathcal{L}_{σ} ending at position ψ , the signature of $x_{i,j}$ contains a maximum word in \mathcal{L}_{σ} starting at λ and ending at ψ , the signature of $x_{i,u}$ contains a maximum word in \mathcal{L}_{σ} starting at λ .

- ① When Condition (iii.a) of Definition 18 holds, by using the function h of Definition 18, Equation (4) can be rewritten as:

$$\begin{array}{c}
\overbrace{1 \ \ell \ i \ \lambda \ \psi \ j \ u \ n}^{f_{\sigma^r}(x_{n,i})=f_{\sigma^r}(x_{u,i})} \\
\underbrace{1 \ \ell \ i \ \lambda \ \psi \ j \ u \ n}_{f_{\sigma}(x_{1,j})=f_{\sigma}(x_{\ell,j})}
\end{array}
f_{\sigma}(x_{i,j}) = \underbrace{h(x_{\ell+b_{\sigma}})}_{f_{\sigma}(x_{1,j})} + \underbrace{h(x_{\lambda+a_{\sigma^r}})}_{f_{\sigma^r}(x_{n,i})} - \underbrace{h(x_{\ell+b_{\sigma}})}_{f_{\sigma}(x_{1,n})} \quad (14)$$

From (14), and by using the fact that $a_{\sigma^r} = b_{\sigma}$, we obtain $f_{\sigma}(x_{i,j}) = h(x_{\lambda+b_{\sigma}})$, which is true by Condition (iii.a) of Definition 18.

- ② When Condition (iii.b) of Definition 18 holds, Equation (4) can be proven in a similar way as in case ①.

Hence, Equation (4) holds. \square

Theorem 5. Consider a pattern σ whose class has a non-empty intersection with the set of representatives $\mathcal{S} = \{\langle \text{PRE}, \text{FAC}, \text{SUF} \rangle, \langle \text{IN}, \text{IN}, \text{IN} \rangle, \langle \text{PRE}, \text{OUT}, \text{OUT} \rangle, \langle \text{OUT}, \text{OUT}, \text{SUF} \rangle, \langle \text{IN}, \text{OUT}, \text{OUT} \rangle, \langle \text{OUT}, \text{OUT}, \text{IN} \rangle\}$. Equation (4) can be used to obtain $f_{\sigma}(x_{i,j})$ for a sequence $x_{1,n}$ wrt a window $[i, j]$ whose type is in \mathcal{S} , assuming that feature f has the SAME VALUE property.

Proof. Because of Remark 1, we only consider the representatives $\langle \text{PRE, FAC, SUF} \rangle$ and $\langle \text{PRE, OUT, OUT} \rangle$.

- [$\langle \text{PRE, FAC, SUF} \rangle$] Since f has the SAME VALUE property, Equation (4) can be rewritten as:

$$f_\sigma(x_{i,j}) = \underbrace{f_\sigma(x_{1,n})}_{f_\sigma(x_{1,j})} + \underbrace{f_\sigma(x_{1,n})}_{f_{\sigma^r}(x_{n,i})} - \underbrace{f_\sigma(x_{1,n})}_{f_\sigma(x_{1,n})} \quad (15)$$

From (15) we obtain $f_\sigma(x_{i,j}) = f_\sigma(x_{1,n})$, which is true by definition of the SAME VALUE property. Hence, Equation (4) holds.

- [$\langle \text{PRE, OUT, OUT} \rangle$] Since f has the SAME VALUE property, Equation (4) can be rewritten as:

$$f_\sigma(x_{i,j}) = \underbrace{f_\sigma(x_{1,n})}_{f_\sigma(x_{1,j})} + \underbrace{0}_{f_{\sigma^r}(x_{n,i})} - \underbrace{f_\sigma(x_{1,n})}_{f_\sigma(x_{1,n})} \quad (16)$$

From (16) we obtain $f_\sigma(x_{i,j}) = 0$, which is true by definition of the representative $\langle \text{PRE, OUT, OUT} \rangle$. Hence, Equation (4) holds. \square

Theorem 6. Consider a pattern σ whose class has a non-empty intersection with the set of representatives $\mathcal{S} = \{\langle \text{PRE, FAC, SUF} \rangle, \langle \text{IN, IN, IN} \rangle, \langle \text{PRE, OUT, OUT} \rangle, \langle \text{OUT, OUT, SUF} \rangle, \langle \text{IN, OUT, OUT} \rangle, \langle \text{OUT, OUT, IN} \rangle\}$. Equation (4) can be used to obtain $f_\sigma(x_{i,j})$ for a sequence $x_{1,n}$ wrt window $[i, j]$ whose type is in \mathcal{S} , assuming that the pair f, σ has the SINGLE POSITION INFLEXION property.

Proof. When the pair f, σ has the SINGLE POSITION INFLEXION property the following identity holds:

$$f_\sigma(x_{k,k'}) = f_\sigma(x_{1,n}), \forall k, k' \mid 1 \leq k \leq k' \leq n, \text{ and} \\ \exists \text{ an extended } \sigma\text{-pattern occurrence in } [k, k'] \text{ wrt } x_{k,k'} \quad (17)$$

Because of Remark 1 we only consider the representatives $\langle \text{PRE, FAC, SUF} \rangle$ and $\langle \text{PRE, OUT, OUT} \rangle$.

- [$\langle \text{PRE, FAC, SUF} \rangle$] By Identity (17) and because all three intervals $[1, j]$, $[i, j]$ and $[i, n]$ contain an extended σ -pattern occurrence, $f_\sigma(x_{1,j}) = f_{\sigma^r}(x_{n,i}) = f_\sigma(x_{i,j}) = f_\sigma(x_{1,n})$; thus Equation (4) can be rewritten as:

$$f_\sigma(x_{i,j}) = \underbrace{f_\sigma(x_{1,n})}_{f_\sigma(x_{1,j})} + \underbrace{f_\sigma(x_{1,n})}_{f_{\sigma^r}(x_{n,i})} - \underbrace{f_\sigma(x_{1,n})}_{f_\sigma(x_{1,n})} \quad (18)$$

From (18) we obtain $f_\sigma(x_{i,j}) = f_\sigma(x_{1,n})$, which is true by definition of the SINGLE POSITION INFLEXION property. Hence, Equation (4) holds.

- [$\langle \text{PRE}, \text{OUT}, \text{OUT} \rangle$] By Identity (17) $f_\sigma(x_{1,j}) = f_\sigma(x_{1,n})$; since there is no extended σ -pattern occurrence neither in $[i, j]$ nor in $[i, n]$, $f_{\sigma^r}(x_{n,i}) = f_\sigma(x_{i,j}) = 0$, and Equation (4) can be rewritten as:

$$f_\sigma(x_{i,j}) = \underbrace{f_\sigma(x_{1,n})}_{f_\sigma(x_{1,j})} + \underbrace{0}_{f_{\sigma^r}(x_{n,i})} - \underbrace{f_\sigma(x_{1,n})}_{f_\sigma(x_{1,n})} \quad (19)$$

From (19) we obtain $f_\sigma(x_{i,j}) = 0$, which is true by definition of the second component of the $\langle \text{PRE}, \text{OUT}, \text{OUT} \rangle$ representative. Hence, Equation (4) holds. \square

Sufficient Conditions for the Validity of Equations (5) and (6)

Theorem 7. *Consider a pattern σ whose class has a non-empty intersection with the set of representatives $\mathcal{S} = \{ \langle \text{PRE}, \text{FAC}, \text{SUF} \rangle, \langle \text{IN}, \text{IN}, \text{IN} \rangle, \langle \text{PRE}, \text{OUT}, \text{OUT} \rangle, \langle \text{OUT}, \text{OUT}, \text{SUF} \rangle, \langle \text{IN}, \text{OUT}, \text{OUT} \rangle, \langle \text{OUT}, \text{OUT}, \text{IN} \rangle, \langle \text{OUT}, \text{OUT}, \text{OUT} \rangle \}$. Equation (5) can be used to obtain $f_\sigma(x_{i,j})$ for a sequence $x_{1,n}$ wrt window $[i, j]$ whose type is in \mathcal{S} , assuming that feature f has the SUM DECOMPOSITION and the POSITIVE properties. If, in addition to the set \mathcal{S} , we also have the representative $\langle \text{PRE}, \text{OUT}, \text{SUF} \rangle$ then Equation (5) can still be used, provided that pattern σ has the EXCLUDE-OUT-IN property.*

Proof. Because of Remark 1 we only consider the representatives $\langle \text{PRE}, \text{FAC}, \text{SUF} \rangle$, $\langle \text{PRE}, \text{OUT}, \text{OUT} \rangle$ and $\langle \text{OUT}, \text{OUT}, \text{OUT} \rangle$.

- [$\langle \text{PRE}, \text{FAC}, \text{SUF} \rangle$] Since, from Theorem 3, Equation (4) is valid for this representative when f has the SUM DECOMPOSITION property, and since f has the POSITIVE property, the right-hand side of Equation (5) is the maximum between zero and a positive value; therefore Equation (5) is also valid for $\langle \text{PRE}, \text{FAC}, \text{SUF} \rangle$.
- [$\langle \text{PRE}, \text{OUT}, \text{OUT} \rangle$] Since f has the POSITIVE and SUM DECOMPOSITION properties, $f_\sigma(x_{1,n}) \geq 0$ and $f_\sigma(x_{1,j}) \leq f_\sigma(x_{1,n})$. Due to the third component “OUT” of the representative $f_{\sigma^r}(x_{n,i}) = 0$. When Equation (4) is used, we obtain $f_\sigma(x_{i,j}) \leq 0$; but with Equation (5) we get $f_\sigma(x_{i,j}) = 0$, which is true due to the second component “OUT” of the representative. Hence (5) is valid.
- [$\langle \text{OUT}, \text{OUT}, \text{OUT} \rangle$] Since f has the POSITIVE property, $f_\sigma(x_{1,n}) \geq 0$. Due to the first and third “OUT” components of the representative, $f_\sigma(x_{1,j}) = f_{\sigma^r}(x_{n,i}) = 0$. When Equation (4) is used, we obtain $f_\sigma(x_{i,j}) \leq 0$; but with Equation (5) we get $f_\sigma(x_{i,j}) = 0$, which is true due to the second component “OUT” of the representative. Hence, Equation (5) is valid.
- [$\langle \text{PRE}, \text{OUT}, \text{SUF} \rangle$]
 - From the CONVEXITY property, the signature of the words $x_{\ell,j}$ and $x_{i,u}$ respectively contain at most one maximum word in \mathcal{L}_σ . Because of PRE and SUF, the signature of the words $x_{\ell,j}$ and $x_{i,u}$ respectively contain at least one word in \mathcal{L}_σ . Consequently, the signature of the words $x_{\ell,j}$ and $x_{i,u}$ contain one single maximum word in \mathcal{L}_σ , respectively denoted by w_{PRE} and w_{SUF} .

- Because of the OUT of $\langle \text{PRE}, \text{OUT}, \text{SUF} \rangle$, the signature of the word $x_{i,j}$ does not contain any subword that belongs to \mathcal{L}_σ . In addition, since the pattern σ has the EXCLUDE-OUT-IN property we have that w_{PRE} ends before position i , and w_{SUF} starts after position j , i.e. w_{PRE} and w_{SUF} do not overlap. Consequently, since in addition f has the POSITIVE and the SUM DECOMPOSITION properties, $f_\sigma(x_{1,n}) \geq 0$ and $f_\sigma(x_{1,j}) + f_{\sigma^r}(x_{n,i}) \leq f_\sigma(x_{1,n})$. When Equation (4) is used, we obtain $f_\sigma(x_{i,j}) \leq 0$; but with Equation (5) we get $f_\sigma(x_{i,j}) = 0$, which is true due to the second component “OUT” of the representative. Hence, Equation (5) is valid. \square

Theorem 8. Consider a pattern σ whose class has a non-empty intersection with the set of representatives $\mathcal{S} = \{\langle \text{PRE}, \text{FAC}, \text{SUF} \rangle, \langle \text{IN}, \text{IN}, \text{IN} \rangle, \langle \text{PRE}, \text{OUT}, \text{OUT} \rangle, \langle \text{OUT}, \text{OUT}, \text{SUF} \rangle, \langle \text{IN}, \text{OUT}, \text{OUT} \rangle, \langle \text{OUT}, \text{OUT}, \text{IN} \rangle, \langle \text{OUT}, \text{OUT}, \text{OUT} \rangle\}$. Equation (5) can be used to obtain $f_\sigma(x_{i,j})$ for a sequence $x_{1,n}$ wrt window $[i, j]$ whose type is in \mathcal{S} , assuming that feature f has the SAME VALUE and the POSITIVE properties.

Proof. Because of Remark 1 we only consider the representatives $\langle \text{PRE}, \text{FAC}, \text{SUF} \rangle$, $\langle \text{PRE}, \text{OUT}, \text{OUT} \rangle$ and $\langle \text{OUT}, \text{OUT}, \text{OUT} \rangle$.

- [$\langle \text{PRE}, \text{FAC}, \text{SUF} \rangle$] Since, from Theorem 5, Equation (4) is valid for this representative when f has the SAME VALUE property, and since f has the POSITIVE property, Equation (5) is the maximum between zero and a positive value; therefore Equation (5) is also valid for $\langle \text{PRE}, \text{FAC}, \text{SUF} \rangle$.
- [$\langle \text{PRE}, \text{OUT}, \text{OUT} \rangle$] Since f has the SAME VALUE property, $f_\sigma(x_{1,j}) = f_\sigma(x_{1,n})$. Due to the third component “OUT” of the $\langle \text{PRE}, \text{OUT}, \text{OUT} \rangle$ representative $f_{\sigma^r}(x_{n,i}) = 0$. Consequently, by Equation (5), we have $f_\sigma(x_{i,j}) = \max(0, f_\sigma(x_{1,j}) + f_{\sigma^r}(x_{n,i}) - f_\sigma(x_{1,n})) = 0$, which is true due to the second component “OUT” of the $\langle \text{PRE}, \text{OUT}, \text{OUT} \rangle$ representative. Hence, Equation (5) is valid.
- [$\langle \text{OUT}, \text{OUT}, \text{OUT} \rangle$] Since f has the POSITIVE property, $f_\sigma(x_{1,n}) \geq 0$. Due to the first and third “OUT” components of the $\langle \text{OUT}, \text{OUT}, \text{OUT} \rangle$ representative, $f_\sigma(x_{1,j}) = f_{\sigma^r}(x_{n,i}) = 0$. When Equation (4) is used, we obtain $f_\sigma(x_{i,j}) \leq 0$; but with Equation (5) we get $f_\sigma(x_{i,j}) = 0$, which is true due to the second component “OUT” of the $\langle \text{OUT}, \text{OUT}, \text{OUT} \rangle$ representative. Hence, Equation (5) is valid. \square

Theorem 9. Consider a pattern σ whose class has a non-empty intersection with the set of representatives $\mathcal{S} = \{\langle \text{PRE}, \text{FAC}, \text{SUF} \rangle, \langle \text{IN}, \text{IN}, \text{IN} \rangle, \langle \text{PRE}, \text{OUT}, \text{SUF} \rangle, \langle \text{IN}, \text{OUT}, \text{IN} \rangle, \langle \text{PRE}, \text{OUT}, \text{OUT} \rangle, \langle \text{IN}, \text{OUT}, \text{OUT} \rangle, \langle \text{OUT}, \text{OUT}, \text{SUF} \rangle, \langle \text{OUT}, \text{OUT}, \text{IN} \rangle, \langle \text{OUT}, \text{OUT}, \text{OUT} \rangle\}$. Equation (6) can be used to obtain $f_\sigma(x_{i,j})$ for a sequence $x_{1,n}$ wrt a window $[i, j]$ whose type is in \mathcal{S} if (a) either both $\langle \text{PRE}, \text{FAC}, \text{SUF} \rangle$ and $\langle \text{IN}, \text{IN}, \text{IN} \rangle$ are not representatives of the pattern σ , (b) or if one of the following conditions holds:

- i) f has the SUM DECOMPOSITION property.
- ii) f has the SAME VALUE property.
- iii) the pair f, σ has the SINGLE POSITION NO-INFLEXION or the SINGLE POSITION INFLEXION properties.

Proof. [CASE 1] Consider the representatives that have an extended σ -pattern occurrence in $[i, j]$. In this case the only two representatives are $\langle \text{PRE, FAC, SUP} \rangle$ and $\langle \text{IN, IN, IN} \rangle$. Since Equation (4) is valid for these representatives when:

- i)* f has the SUM DECOMPOSITION property (see Theorem 3),
 - ii)* f has the SAME VALUE property (see Theorem 5),
 - iii)* the pair f, σ has the SINGLE POSITION NO-INFLEXION property (see Theorem 4) or the SINGLE POSITION INFLEXION property (see Theorem 6),
- Equation (6) is also valid.

[CASE 2] Consider the representatives that do not have an extended σ -pattern occurrence in $[i, j]$. When using Equation (6), because of the check “if no σ -pattern in $x_{i,j}$ ” in Equation (6), the value of $f_\sigma(x_{i,j})$ is zero. Hence, Equation (6) is valid. \square

Synthesis The classification induced by theorems 3 to 9 is presented in Table 4: for each pattern class corresponding to the same set of representative triples (see Figure 3) we select one pattern (see the columns of Table 4, e.g. Plain) and provide for each feature property (see the rows of Table 4, e.g. SV) and for each feature/pattern property (see the cells of Table 4, e.g. SPN) the theorem proving that an Equation is valid under such properties. Note that any missing Equation is due to a counterexample given in Appendix B, and not to the fact that we are missing a theorem. Coloured grey cells indicate a non-existing time-series constraint in the time-series catalogue [3].

Equation (6) can be used to compute the value of $f_\sigma(x_{i,j})$, for all reversible and convex patterns without the SINGLE LETTER property from [3], except for Zigzag with the max and min features (see the cells marked with “none” in Table 4), as Zigzag uses the representative triple $\langle \text{IN, IN, IN} \rangle$ without having the SINGLE POSITION INFLEXION or the SINGLE POSITION NO-INFLEXION properties.

4.2 Optimal Time Complexity Checkers

Since checking each window of m consecutive positions of a sequence of size n independently gives a time complexity of $O(m \cdot n)$, we now introduce a theorem leading to an optimal time complexity.

Theorem 10. *The time complexity of evaluating Equations (4) and (5) on a sequence $\mathcal{X} = x_1x_2 \dots x_n$ for all sliding windows of size m is $\Theta(n)$. Moreover, assuming one can check in constant time whether a sliding window of the sequence \mathcal{X} contains or not a σ -pattern, the time complexity of evaluating Equation (6) for all sliding windows of size m of sequence \mathcal{X} is also $\Theta(n)$.*

Proof. Evaluating (4), (5) and (6) for all sliding windows $[i, j]$ (with $i \in [1, n - m + 1]$ and $j = i + m - 1$) requires evaluating $f_\sigma(x_{1,i+m-1})$, $f_\sigma(x_{i,n})$ and $f_\sigma(x_{1,n})$.

- First, note that within Equation (6) all the tests “if no σ -pattern in $x_{i,j}$ ” on the different sliding windows (with $i \in [1, n - m + 1]$ and $j = i + m - 1$) can be done in $O(n)$ because of our assumption.

		REPRESENTATIVE TRIPLES						
		(P, O, S)	(P, F, S)	(O, O, O)	(I, O, O)	(O, O, I)	(I, O, I)	(I, I, I)
		(P, F, S)	(P, O, O)	(O, O, S)	(O, O, O)	(I, I, I)		
		(P, F, S)	(P, O, O)	(O, O, S)	(O, O, O)	(I, O, O)	(O, O, I)	
		N,E	O	O	O			N,E
		$f \setminus \sigma$	DecSeq	Gorge	Valley	Plain	Zigzag	SteadySeq
FEATURE PROPERTIES	P	one	9(6)	5(4),8(5),9(6)	8(5),9(6)	8(5),9(6)	9(6)	5(4),8(5),9(6)
	SV	width	7(5),9(6)	7(5),9(6)	7(5),9(6)	7(5),9(6)	9(6)	3(4),7(5),9(6)
	SD	surf	9(6)	9(6)	9(6)	9(6)	9(6)	3(4),9(6)
	SP	max	SPN 9(6)				none	
		min	SPN 9(6)	SPO 6(4),9(6)	SPO 9(6)	SPO 9(6)	none	SPN 4(4),9(6)

Table 4: Indicates, for existing combinations of feature f and pattern σ from the time-series catalogue, which of the Equations (4), (5) and (6) are valid, as well as the corresponding justifying theorem, where: (i) within a representative triple we use as a shortcut the first letter of each component; (ii) P, SP, SD and SV resp. indicate whether the feature f has the POSITIVE, the SINGLE POSITION, the SUM DECOMPOSITION or the SAME VALUE property; (iii) N, E, and O resp. indicate whether the pattern σ has the NO-INFLEXION, the EXCLUDE-OUT-IN or the ONE-INFLEXION property; (iv) SPN, SPO resp. indicate whether the pair f, σ has the SINGLE POSITION NO-INFLEXION property or the SINGLE POSITION INFLEXION property.

- Second, evaluating $f_\sigma(x_{1,i+m-1})$ for all $i \in [1, n - m + 1]$ as well as $f_\sigma(x_{1,n})$ can be done in $O(n)$ by using a register automaton [6] for $\text{SUM}_f_\sigma(r, x_1x_2 \dots x_n)$, which exposes all its intermediate register values [9].
- Third, since the pattern σ is reversible and since the feature f is commutative, $f_\sigma(x_{i,n}) = f_{\sigma^r}(x_{n,i})$. Evaluating $f_{\sigma^r}(x_{n,i})$ for all $i \in [1, n - m + 1]$ can also be done in $O(n)$ by using a register automaton for $\text{SUM}_f_\sigma(r, x_nx_{n-1} \dots x_1)$, which exposes all its intermediate register values.

Therefore, the time complexity of evaluating Equations (4), (5) and (6) is $O(n)$. Since each variable of $x_{1,n}$ needs to be scanned at least once to identify pattern occurrences, this time complexity is optimum. \square

Pattern Properties for Checking in Linear Time the Occurrence of Pattern in Sliding Windows We now introduce some additional pattern properties to check in time $O(n)$ whether or not the different sliding windows of size m of a sequence $\mathcal{X} = x_1x_2 \dots x_n$ contain a pattern occurrence. As these properties cover all reversible patterns of the time-series catalogue, one can also use Equation (6) for such patterns for the entries of Table 4 mentioning (6).

Definition 20. A pattern σ has the **LETTER** property wrt a letter e if e is a word in \mathcal{L}_σ , and if any word of \mathcal{L}_σ contains at least one occurrence of e , i.e. if $\mathcal{L}_\sigma \cap \{e\} \neq \emptyset$ and if $\mathcal{L}_\sigma \cap (\Sigma \setminus e)^* = \emptyset$.

Definition 21. A pattern σ has the **SUFFIX-UNAVOIDABLE** property wrt a letter $e \in \{ '<', '=', '>' \}$ if all words in \mathcal{L}_σ contain at least one occurrence of e , and if each suffix starting with the letter e of any word of \mathcal{L}_σ belongs also to \mathcal{L}_σ , i.e. if $\mathcal{L}_\sigma \cap (\Sigma \setminus e)^* = \emptyset$ and if $\text{shuffle}(\mathcal{L}_\sigma, s) \wedge \Sigma^* s e \Sigma^* \wedge \Sigma^* s (\Sigma^* \setminus \mathcal{L}_\sigma) = \emptyset$.

Definition 22. A pattern σ has the **INCOMPRESSIBLE** property if all proper factors of any word in \mathcal{L}_σ do not belong to \mathcal{L}_σ , i.e. if $\Sigma^+ \mathcal{L}_\sigma \Sigma^* \cap \mathcal{L}_\sigma = \emptyset$ and if $\Sigma^* \mathcal{L}_\sigma \Sigma^+ \cap \mathcal{L}_\sigma = \emptyset$.

Definition 23. A pattern σ has the **FACTOR** property if for any word w in \mathcal{L}_σ all factors of w , whose length is greater than or equal to the smallest length ω_σ of a word in \mathcal{L}_σ , belong also to \mathcal{L}_σ , i.e. if $\text{shuffle}(\text{shuffle}(\mathcal{L}_\sigma, s), s) \wedge \Sigma^* s \Sigma^* \Sigma^{\omega_\sigma} \Sigma^* s \Sigma^* \wedge \Sigma^* s (\Sigma^* \setminus \mathcal{L}_\sigma) s \Sigma^* = \emptyset$.

Example 9 (pattern properties, continuation of Example 4).

- Eight out of the 19 reversible patterns of [3] have the **LETTER** property. For instance, the patterns **Dec**, **DecSeq** and **StrictlyDecSeq** all have the **LETTER** property wrt $\{ '>' \}$ since (i) the word $'>'$ is in \mathcal{L}_{Dec} , in $\mathcal{L}_{\text{DecSeq}}$ and in $\mathcal{L}_{\text{StrictlyDecSeq}}$, and (ii) any word in \mathcal{L}_{Dec} , in $\mathcal{L}_{\text{DecSeq}}$ or in $\mathcal{L}_{\text{StrictlyDecSeq}}$ contains at least one occurrence of $'>'$.
- 16 out of the 19 reversible patterns of [3] have the **SUFFIX-UNAVOIDABLE** property. For instance, the pattern **Peak** has the **SUFFIX-UNAVOIDABLE** property wrt the letter $'<'$, since (i) any occurrence of peak contains at least one occurrence of $'<'$, and since (ii) any suffix, starting with a $'<'$, of a word of $\mathcal{L}_{\text{Peak}}$ is also a peak.
- Six out of the 19 reversible patterns of [3] have the **INCOMPRESSIBLE** property. The pattern **DecTerrace** has the **INCOMPRESSIBLE** property because, if an occurrence of the letter $'>'$ is removed from any word in $\mathcal{L}_{\text{DecTerrace}}$, the corresponding proper factor is not in $\mathcal{L}_{\text{DecTerrace}}$.
- Seven out of the 19 reversible patterns of [3] have the **FACTOR** property. For instance, the pattern **Zigzag** has the **FACTOR** property because any factor of length greater than or equal to $\omega_{\text{zigzag}} = 3$ of a zigzag is also a zigzag.

For each pattern property described in Definitions 20 to 23 we now show how to check in $O(n)$ which sliding windows are empty or not.

- Consider a pattern σ that has the **LETTER** property wrt a letter e . First compute in one scan the number of occurrences $\text{nocc}[k]$ of e in $x_{1,k}$ for all $k \in [1, n]$; second, for each sliding window $[i, j]$, check in constant time that $\text{nocc}[i] = \text{nocc}[j]$.
- Consider a pattern σ that has the **SUFFIX-UNAVOIDABLE** property wrt a letter e . First compute in one scan the number of occurrences $\text{nocc1}[k]$ of e in

$x_{1,k}$ for all $k \in [1, n]$; second compute in one scan the number of maximal occurrences $noc2[k]$ of pattern σ in $x_{1,k}$ for all $k \in [1, n]$; third, for each sliding window $[i, j]$, check in constant time that $noc1[i] = noc1[j] \vee noc2[i] = noc2[j]$.

- Consider a pattern σ that has the INCOMPRESSIBLE or the FACTOR property. First compute for each $k = 1, 2, \dots, n$ the end $end[k]$ of the next pattern occurrence (which will be set to $n + 1$ if no pattern occurrence ends after k , e.g. $end[n] = n + 1$). Second compute for each $k = n, n - 1, \dots, 1$ the start $start[k]$ of the previous pattern occurrence (which will be set to 0 if no pattern occurrence starts before k , e.g. $start[1] = 0$). Third, depending on whether the pattern has the INCOMPRESSIBLE or the FACTOR property, do the following check in constant time for each sliding window $[i, j]$:

- [INCOMPRESSIBLE] **return** $end[i] > j \vee start[j] < i$
- [FACTOR] $endi = end[i], startj = start[j]$
if $endi > n \vee startj < 1$ **then return true**
if $endi - i \geq \omega_\sigma$ **then** $i' = i$ **else** $i' = endi$
if $j - startj \geq \omega_\sigma$ **then** $j' = j$ **else** $j' = startj$
 $endi' = end[i'], startj' = start[j']$
if $endi' > n \vee startj' < 1$ **then return true**
return $\min(j', endi') - \max(i', start[\min(j', endi')]) < \omega_\sigma$

Computing the end (resp. start) of the next (resp. previous) pattern occurrence is done by using a register automaton derived from the transducer [6] which recognises pattern occurrences.² Figure 5 give the register automaton associated with the Plain and the Zigzag patterns. In (A), the dotted transition marks the end of a plain. In (B), the dashed (resp. dotted) transitions indicate that we are inside a zigzag (resp. that a zigzag is ending). Depending whether we were in a zigzag or not we set $end[n - 1]$ to n or to $n + 1$.

Example 10 (Running automata that compute the end of the next pattern occurrence). Table 5 (resp. Table 6) shows an example of execution of the register automaton given in Part (A) (resp. (B)) of Figure 5.

4.3 Optimal Space Complexity Reformulation

Rather than stating a time-series constraint on each window of size m , which would result in an $O(m \cdot n)$ space complexity, we now show how to reformulate the $SLIDE_SUM_f_ \sigma(m, low, up, x_1 x_2 \dots x_n)$ constraint as a conjunction of constraints with a space complexity of $\Theta(n)$. This reformulation was extended to the patterns of Table 1 for Equation (6) to reformulate condition “if no σ -pattern in $x_{i,j}$ ”, but is not described here for space reasons.

Theorem 11. *For those time-series constraints for which Equations (4) or (5) holds, the constraint $SLIDE_SUM_f_ \sigma(m, low, up, x_1 x_2 \dots x_n)$ can be reformulated with a space complexity of $\Theta(n)$.*

² How to generate a transducer that recognises all maximal pattern occurrences was described in [17].

Proof. For Equation (4), it can be reformulated as the conjunction

$$\begin{cases} \text{SUM_f_}\sigma(r, x_1x_2\dots x_n, \vec{r}_1\vec{r}_2\dots\vec{r}_n) \wedge \\ \text{SUM_f_}\sigma(r, x_nx_{n-1}\dots x_1, \overleftarrow{r}_1\overleftarrow{r}_2\dots\overleftarrow{r}_n) \wedge \\ \forall i \in [1, n-m+1] : r_{i,j} = \vec{r}_j + \overleftarrow{r}_i - r \text{ (with } j = i+m-1) \wedge \\ \text{low} = \min(r_{1,m}r_{2,m+1}\dots r_{n-m+1,n}) \wedge \\ \text{up} = \max(r_{1,m}r_{2,m+1}\dots r_{n-m+1,n}) \end{cases} \quad (20)$$

where \overleftarrow{r}_i (resp. \vec{r}_j) is the exposed register value corresponding to the first argument of $\text{SUM_f_}\sigma(\vec{r}_j, x_1x_2\dots x_j)$, (resp. $\text{SUM_f_}\sigma^r(\overleftarrow{r}_i, x_nx_{n-1}\dots x_i)$). For Equation (5), we replace in (20) the term $r_{i,j} = \vec{r}_j + \overleftarrow{r}_i - r$ by the term $r_{i,j} = \max(0, \vec{r}_j + \overleftarrow{r}_i - r)$. \square

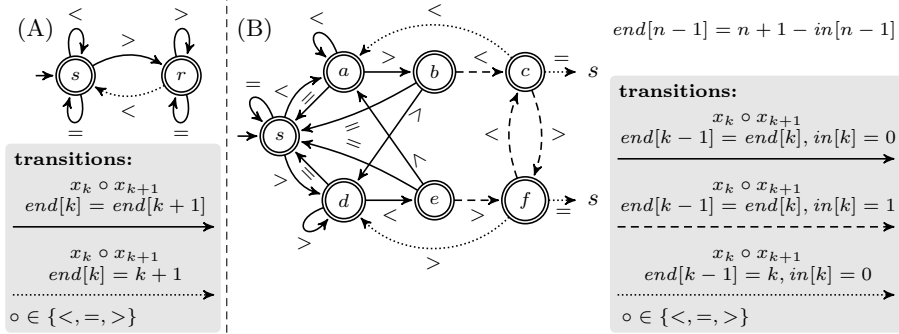

Fig. 5: Register automata computing the end of the next pattern maximal occurrence for (A) the Plain and (B) the Zigzag patterns

x_k	0 1 0 1 0 0 1 0 1 2 0	x_k	1 0 2 1 0 1 0 0 1 0 1
s_k	< > < > = < > < < > <	s_k	> < > > < > = < > < >
x_{k+1}	1 0 1 0 0 1 0 1 2 0 1	x_{k+1}	0 2 1 0 1 0 0 1 0 1 0
$k+1$	2 3 4 5 6 7 8 9 10 11 12	$k+1$	11 10 9 8 7 6 5 4 3 2 1
$\text{end}[k]$	4 4 4 7 7 7 9 9 12 12 12	$\text{end}[k]$	10 10 7 7 7 4 4 4 2 2 0
$\text{end}[k+1]$	4 4 7 7 7 9 9 12 12 12 13	$\text{end}[k+1]$	10 7 7 7 4 4 4 2 2 0 0

(A1) (A2)

Table 5: Running the register automaton of Figure 5 that computes the end of the next plain on (A1) the sequence $x = 010100101201$ and (A2) on its reverse

x_k	0 1 0 1 0 0 1 0 1 2 0	x_k	1 0 2 1 0 1 0 0 1 0 1
s_k	< > < > = < > < < > <	s_k	> < > > < > = < > < >
x_{k+1}	1 0 1 0 0 1 0 1 2 0 1	x_{k+1}	0 2 1 0 1 0 0 1 0 1 0
k	1 2 3 4 5 6 7 8 9 10 11	k	12 11 10 9 8 7 6 5 4 3 2
$end[k-1]$	5 5 5 5 5 9 9 9 9 12 12	$end[k-1]$	9 9 9 9 6 6 6 1 1 1 1
$end[k]$	5 5 5 5 9 9 9 9 12 12 12	$end[k]$	9 9 9 6 6 6 1 1 1 1 1
$in[k]$	0 0 1 1 0 0 0 1 0 0 1	$in[k]$	0 0 1 0 0 1 0 0 0 1 1

(B1) (B2)

Table 6: Running the register automaton of Figure 5 that computes the end of the next zigzag on (B1) the sequence $x = 010100101201$ and (B2) on its reverse

5 Conclusion

Based on a detailed analysis of feature and pattern properties of time-series constraints of the time-series catalogue that use the Sum aggregator, we came up with a $\Theta(n)$ time complexity checker, and a $\Theta(n)$ space complexity reformulation for such constraints. It is an open question how to generalise our results to other aggregators such as min or max. Unlike the sum aggregator, the equality $g(a, x) = b$ where a, b are fixed integers and x is a variable does not uniquely determine x when $g \in \{\min, \max\}$.

Acknowledgment We thank Pierre Flener for some feedback on an early version of this paper, and Colin de la Higuera for discussions on regular expressions, on the properties of their languages and on operators such as shuffle.

References

1. Alur, R., Fisman, D., Raghothaman, M.: Regular programming for quantitative properties of data streams. In: Thiemann, P. (ed.) Programming Languages and Systems - 25th European Symposium on Programming, ESOP 2016, Held as Part of the European Joint Conferences on Theory and Practice of Software, ETAPS 2016, Eindhoven, The Netherlands, April 2-8, 2016, Proceedings. Lecture Notes in Computer Science, vol. 9632, pp. 15–40. Springer (2016)
2. Arafailova, E., Beldiceanu, N., Douence, R., Carlsson, M., Flener, P., Rodríguez, M.A.F., Pearson, J., Simonis, H.: Global constraint catalog, volume ii, time-series constraints. CoRR abs/1609.08925 (2016), <http://arxiv.org/abs/1609.08925>
3. Arafailova, E., Beldiceanu, N., Douence, R., Carlsson, M., Flener, P., Rodríguez, M.A.F., Pearson, J., Simonis, H.: Global constraint catalog, volume II, time-series constraints. arXiv preprint arXiv:1609.08925 (2016)
4. Beldiceanu, N., Contejean, E.: Introducing Global Constraints in CHIP. Mathl. Comput. Modelling 20(12), 97–123 (1994)
5. Beldiceanu, N., Carlsson, M.: Revisiting the cardinality operator and introducing the cardinality-path constraint family. In: Codognet, P. (ed.) ICLP 2001. LNCS, vol. 2237, pp. 59–73. Springer (2001)

6. Beldiceanu, N., Carlsson, M., Douence, R., Simonis, H.: Using finite transducers for describing and synthesising structural time-series constraints. *Constraints* 21(1), 22–40 (January 2016), journal fast track of CP 2015: summary on p. 723 of LNCS 9255, Springer, 2015
7. Beldiceanu, N., Carlsson, M., Petit, T.: Deriving filtering algorithms from constraint checkers. In: Wallace, M. (ed.) CP 2004. LNCS, vol. 3258, pp. 107–122. Springer (2004)
8. Bessière, C., Hebrard, E., Hnich, B., Kiziltan, Z., Walsh, T.: SLIDE: A useful special case of the CARDPATH constraint. In: Ghallab, M., et al. (eds.) ECAI 2008. pp. 475–479. IOS Press (2008)
9. Carlsson, M., al.: SICStus Prolog User’s Manual. RISE SICS AB, 4.5.1 edn. (April 2019)
10. Hopcroft, J.E., Motwani, R., Ullman, J.D.: *Introduction to Automata Theory, Languages, and Computation*. Addison-Wesley, 3rd edn. (2007)
11. Lallouet, A., Law, Y.C., Lee, J.H., Siu, C.F.K.: Constraint programming on infinite data streams. In: Walsh, T. (ed.) IJCAI 2011, Proceedings of the 22nd International Joint Conference on Artificial Intelligence, Barcelona, Catalonia, Spain, July 16–22, 2011. pp. 597–604. IJCAI/AAAI (2011)
12. Lee, J.C.H., Lee, J.H.M., Zhong, A.Z.: Augmenting stream constraint programming with eventuality conditions. In: Hooker, J.N. (ed.) *Principles and Practice of Constraint Programming - 24th International Conference, CP 2018, Lille, France, August 27–31, 2018, Proceedings*. Lecture Notes in Computer Science, vol. 11008, pp. 242–258. Springer (2018)
13. Maher, M.J., Narodytska, N., Quimper, C.G., Walsh, T.: Flow-Based Propagators for the *sequence* and Related Global Constraints. In: Stuckey, P.J. (ed.) *Principles and Practice of Constraint Programming (CP’2008)*. LNCS, vol. 5202, pp. 159–174. Springer-Verlag (2008)
14. Pesant, G.: A regular language membership constraint for finite sequences of variables. In: Wallace, M. (ed.) CP 2004. LNCS, vol. 3258, pp. 482–495. Springer (2004)
15. Picard-Cantin, É., Bouchard, M., Quimper, C., Sweeney, J.: Learning Parameters for the Sequence Constraint from Solutions. In: Rueher, M. (ed.) *Principles and Practice of Constraint Programming (CP’2016)*. LNCS, vol. 9892, pp. 405–420. Springer-Verlag (2016)
16. Régin, J.C., Puget, J.F.: A Filtering Algorithm for Global Sequencing Constraints. In: Smolka, G. (ed.) *Principles and Practice of Constraint Programming (CP’97)*. LNCS, vol. 1330, pp. 32–46. Springer-Verlag (1997)
17. Rodríguez, M.A.F., Flener, P., Pearson, J.: Automatic generation of descriptions of time-series constraints. In: 29th IEEE International Conference on Tools with Artificial Intelligence, ICTAI 2017, Boston, MA, USA, November 6–8, 2017. pp. 102–109. IEEE Computer Society (2017)
18. Vaandrager, F.: Model learning. *Communications of the ACM* 60(2), 86–95 (February 2017)

A List of Feasible Types with Corresponding Witnesses

Table 7 provides for each of the 61 feasible type $\langle t_1, t_2, t_3 \rangle$ that occurs in the map shown by Figure 1, a regular expression for which the language defined by Theorem 2 is not empty. For instance, the type $\langle \text{suf}, \text{fac}, \text{pre} \rangle$ can be obtained

from the following regular expression ' $\langle \lll = \lll \langle \lll = \langle \lll = \langle \lll = \rangle \rangle \rangle \rangle$ ' as illustrated by the figure below.

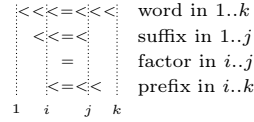

Triple	Witness	Triple	Witness
$\langle \text{fac}, \text{fac}, \text{fac} \rangle$	$\lll = \lll \mid =$	$\langle \text{out}, \text{out}, \text{pre} \rangle$	$\lll = \langle \mid < =$
$\langle \text{fac}, \text{fac}, \text{in} \rangle$	$\lll = \lll \mid =$	$\langle \text{out}, \text{out}, \text{suf} \rangle$	$\lll = \mid =$
$\langle \text{fac}, \text{fac}, \text{pre} \rangle$	$\lll = \lll \langle \mid < = \lll \mid = \lll \mid =$	$\langle \text{pre}, \text{fac}, \text{fac} \rangle$	$\lll = \lll = \mid <$
$\langle \text{fac}, \text{fac}, \text{suf} \rangle$	$\lll = \lll = \mid =$	$\langle \text{pre}, \text{fac}, \text{in} \rangle$	$\lll = \lll = \langle \mid = \lll = \langle \mid <$
$\langle \text{fac}, \text{out}, \text{fac} \rangle$	$\lll = \lll = \langle \mid =$	$\langle \text{pre}, \text{fac}, \text{pre} \rangle$	$\lll = \lll = \lll \langle \mid < = \lll \langle \mid < = \mid =$
$\langle \text{fac}, \text{out}, \text{in} \rangle$	$\lll = \lll = \langle \mid < =$	$\langle \text{pre}, \text{fac}, \text{suf} \rangle$	$\lll = \lll = \langle \mid <$
$\langle \text{fac}, \text{out}, \text{out} \rangle$	$\lll = \lll \mid =$	$\langle \text{pre}, \text{out}, \text{fac} \rangle$	$\lll = \lll = \langle \mid <$
$\langle \text{fac}, \text{out}, \text{pre} \rangle$	$\lll = \lll \langle \rangle \mid < \langle \mid =$	$\langle \text{pre}, \text{out}, \text{in} \rangle$	$\lll = \lll = \langle \mid < =$
$\langle \text{fac}, \text{out}, \text{suf} \rangle$	$\lll = \lll = \mid =$	$\langle \text{pre}, \text{out}, \text{out} \rangle$	$\lll = \lll = \mid <$
$\langle \text{fac}, \text{pre}, \text{in} \rangle$	$\lll = \lll = \mid =$	$\langle \text{pre}, \text{out}, \text{pre} \rangle$	$\lll = \lll = \langle \mid < =$
$\langle \text{fac}, \text{pre}, \text{pre} \rangle$	$\lll = \lll \langle \mid =$	$\langle \text{pre}, \text{out}, \text{suf} \rangle$	$\lll = \lll \langle \mid <$
$\langle \text{in}, \text{fac}, \text{fac} \rangle$	$\lll = \lll = \langle \mid =$	$\langle \text{pre}, \text{pre}, \text{in} \rangle$	$\lll = \lll \langle \mid <$
$\langle \text{in}, \text{fac}, \text{in} \rangle$	$\lll = \lll = \lll \langle \mid < = \lll = \langle \mid < = \lll \mid =$	$\langle \text{pre}, \text{pre}, \text{pre} \rangle$	$\lll = \lll = \mid <$
$\langle \text{in}, \text{fac}, \text{pre} \rangle$	$\lll = \lll = \lll \langle \mid < = \lll = \langle \mid < = \lll \mid =$	$\langle \text{suf}, \text{fac}, \text{fac} \rangle$	$\lll = \lll = \lll \langle \mid < = \lll = \langle \mid < = \mid =$
$\langle \text{in}, \text{fac}, \text{suf} \rangle$	$\lll = \lll = \langle \mid < = \lll = \langle \mid =$	$\langle \text{suf}, \text{fac}, \text{in} \rangle$	$\lll = \lll = \lll \langle \mid < = \lll = \langle \mid < = \lll \mid =$
$\langle \text{in}, \text{in}, \text{in} \rangle$	$\lll = \lll \mid <$	$\langle \text{suf}, \text{fac}, \text{pre} \rangle$	$\lll = \lll = \lll \langle \mid < = \lll = \langle \mid < = \lll \mid =$
$\langle \text{in}, \text{in}, \text{pre} \rangle$	$\lll = \lll = \langle \mid <$	$\langle \text{suf}, \text{fac}, \text{suf} \rangle$	$\lll = \lll = \lll \langle \mid < = \lll = \langle \mid < = \lll \mid =$
$\langle \text{in}, \text{out}, \text{fac} \rangle$	$\lll = \lll = \langle \mid < =$	$\langle \text{suf}, \text{in}, \text{in} \rangle$	$\lll = \lll = \mid =$
$\langle \text{in}, \text{out}, \text{in} \rangle$	$\lll = \lll \langle \mid < \langle$	$\langle \text{suf}, \text{in}, \text{pre} \rangle$	$\lll = \lll \langle \mid =$
$\langle \text{in}, \text{out}, \text{out} \rangle$	$\lll = \lll \langle \mid <$	$\langle \text{suf}, \text{out}, \text{fac} \rangle$	$\lll = \lll = \langle \mid < = \mid >$
$\langle \text{in}, \text{out}, \text{pre} \rangle$	$\lll = \lll = \langle \mid < \langle$	$\langle \text{suf}, \text{out}, \text{in} \rangle$	$\lll = \lll = \mid = =$
$\langle \text{in}, \text{out}, \text{suf} \rangle$	$\lll = \lll = \langle \mid < =$	$\langle \text{suf}, \text{out}, \text{out} \rangle$	$\lll = \lll = \langle \mid < =$
$\langle \text{in}, \text{pre}, \text{in} \rangle$	$\lll = \lll = \langle \mid < = \langle \mid <$	$\langle \text{suf}, \text{out}, \text{pre} \rangle$	$\lll = \lll = \langle \mid = =$
$\langle \text{in}, \text{pre}, \text{pre} \rangle$	$\lll = \lll = \langle \mid <$	$\langle \text{suf}, \text{out}, \text{suf} \rangle$	$\lll = \lll = \langle \mid < =$
$\langle \text{in}, \text{suf}, \text{fac} \rangle$	$\lll = \lll = \langle \mid <$	$\langle \text{suf}, \text{pre}, \text{in} \rangle$	$\lll = \lll = \langle \mid < = \langle \mid =$
$\langle \text{in}, \text{suf}, \text{in} \rangle$	$\lll = \lll = \langle \mid = \lll = \langle \mid <$	$\langle \text{suf}, \text{pre}, \text{pre} \rangle$	$\lll = \lll = \lll \langle \mid < = \lll = \langle \mid <$
$\langle \text{in}, \text{suf}, \text{pre} \rangle$	$\lll = \lll = \langle \mid = \lll = \langle \mid <$	$\langle \text{suf}, \text{suf}, \text{fac} \rangle$	$\lll = \lll = \langle \mid =$
$\langle \text{in}, \text{suf}, \text{suf} \rangle$	$\lll = \lll = \mid =$	$\langle \text{suf}, \text{suf}, \text{in} \rangle$	$\lll = \lll = \langle \mid =$
$\langle \text{out}, \text{out}, \text{fac} \rangle$	$\lll = \lll = \langle \mid =$	$\langle \text{suf}, \text{suf}, \text{pre} \rangle$	$\lll = \lll = \lll \langle \mid < = \lll = \langle \mid =$
$\langle \text{out}, \text{out}, \text{in} \rangle$	$\lll = \lll = \mid =$	$\langle \text{suf}, \text{suf}, \text{suf} \rangle$	$\lll = \lll = \mid =$
$\langle \text{out}, \text{out}, \text{out} \rangle$	$\lll = \lll = \langle \mid < \langle \langle$		

Table 7: List of feasible types and associated regular expressions witnesses

B Counterexamples for Equations (4), (5) and (6)

For each time-series constraint of the time-series constraint catalogue this appendix provides small time series corresponding to counterexamples of the validity of Equations (4), (5) and (6) for all equations missing in Table 4. For instance, for NB_DECREASING_SEQUENCE and Equation (4), we get the following counterexample: consider the three windows of size 2 wrt the sequence $\langle 1, 0, 0, -1 \rangle$; using Equation (4) returns $\langle 1, 1, 1 \rangle$ rather than the expected values $\langle 1, 0, 1 \rangle$, i.e. on the second subsequence “0,0”, (4) returns $1 + 1 - 1 = 1$ rather than the expected value 0; Value 0 reflects the fact that subsequence “0,0” does not contain any decreasing sequence.

constraint	(4)	(5)	(6)
NB_DECREASING_SEQUENCE	2, $\langle 1, 0, 0, -1 \rangle$, $\langle 1, 0, 1 \rangle$, $\langle 1, 1, 1 \rangle$	2, $\langle 1, 0, 0, -1 \rangle$, $\langle 1, 0, 1 \rangle$, $\langle 1, 1, 1 \rangle$	-
SUM_WIDTH_DECREASING_SEQUENCE	2, $\langle 1, 0, 0, -1 \rangle$, $\langle 2, 0, 0, 2 \rangle$, $\langle 2, -1, -1, 2 \rangle$	-	-
SUM_SURF_DECREASING_SEQUENCE	2, $\langle -1, -2, -2, -2, -3, 2 \rangle$, $\langle -3, 0, 0, -5, 0 \rangle$, $\langle -3, 2, 2, -5, 0 \rangle$	2, $\langle -1, 0, -1 \rangle$, $\langle 0, -1 \rangle$, $\langle 0, 0 \rangle$	-
SUM_MAX_DECREASING_SEQUENCE	2, $\langle 1, -1, -1, -2 \rangle$, $\langle 1, 0, -1 \rangle$, $\langle 1, -1, -1 \rangle$	2, $\langle -2, -3, 2 \rangle$, $\langle -2, 0 \rangle$, $\langle 0, 0 \rangle$	-
SUM_MIN_DECREASING_SEQUENCE	2, $\langle 1, -1, -1, -2 \rangle$, $\langle -1, 0, -2 \rangle$, $\langle -1, -1, -2 \rangle$	2, $\langle -1, 0, -1 \rangle$, $\langle 0, -1 \rangle$, $\langle 0, 0 \rangle$	-
NB_DECREASING_TERRACE	2, $\langle 1, 0, 0, -1 \rangle$, $\langle 0, 0, 0 \rangle$, $\langle 0, -1, 0 \rangle$	-	-
SUM_WIDTH_DECREASING_TERRACE	2, $\langle 1, 0, 0, -1 \rangle$, $\langle 0, 0, 0 \rangle$, $\langle 0, -2, 0 \rangle$	-	-
SUM_SURF_DECREASING_TERRACE	2, $\langle 1, -1, -1, -2 \rangle$, $\langle 0, 0, 0 \rangle$, $\langle 0, 2, 0 \rangle$	2, $\langle 1, -1, -1, -2 \rangle$, $\langle 0, 0, 0 \rangle$, $\langle 0, 2, 0 \rangle$	-
SUM_HEIGHT_DECREASING_TERRACE	2, $\langle 1, -1, -1, -2 \rangle$, $\langle 0, 0, 0 \rangle$, $\langle 0, 1, 0 \rangle$	2, $\langle 1, -1, -1, -2 \rangle$, $\langle 0, 0, 0 \rangle$, $\langle 0, 1, 0 \rangle$	-
NB_CORCE	-	-	-
SUM_WIDTH_CORCE	2, $\langle 0, -1, 0, 1 \rangle$, $\langle 0, 0, 0 \rangle$, $\langle 0, -1, 0 \rangle$	-	-
SUM_SURF_CORCE	2, $\langle -3, -4, 2, 3 \rangle$, $\langle 0, 0, 0 \rangle$, $\langle 0, -2, 0 \rangle$	3, $\langle 0, -1, 0 \rangle$, $\langle -1 \rangle$, $\langle 0 \rangle$	-
SUM_MIN_CORCE	-	3, $\langle 0, -1, 0 \rangle$, $\langle -1 \rangle$, $\langle 0 \rangle$	-
NB_INCREASING_SEQUENCE	2, $\langle -1, 0, 0, 1 \rangle$, $\langle 1, 0, 1 \rangle$, $\langle 1, 1, 1 \rangle$	2, $\langle -1, 0, 0, 1 \rangle$, $\langle 1, 0, 1 \rangle$, $\langle 1, 1, 1 \rangle$	-
SUM_WIDTH_INCREASING_SEQUENCE	2, $\langle -3, 0, 0, 0, 3 \rangle$, $\langle 2, 0, 0, 2 \rangle$, $\langle 2, -1, -1, 2 \rangle$	-	-
SUM_SURF_INCREASING_SEQUENCE	2, $\langle -2, -1, -1, -1, 1 \rangle$, $\langle -3, 0, 0, 0 \rangle$, $\langle -3, 1, 1, 0 \rangle$	2, $\langle -2, -2, 1 \rangle$, $\langle 0, -1 \rangle$, $\langle 0, 0 \rangle$	-
SUM_MAX_INCREASING_SEQUENCE	2, $\langle -2, -1, -1, 2 \rangle$, $\langle -1, 0, 2 \rangle$, $\langle -1, -1, 2 \rangle$	2, $\langle -2, -1, 1 \rangle$, $\langle -1, 1 \rangle$, $\langle 0, 1 \rangle$	-
SUM_MIN_INCREASING_SEQUENCE	2, $\langle -2, -1, -1, 2 \rangle$, $\langle -2, 0, -1 \rangle$, $\langle -2, -1, -1 \rangle$	2, $\langle -1, -1, 1 \rangle$, $\langle 0, -1 \rangle$, $\langle 0, 0 \rangle$	-
NB_INCREASING_TERRACE	2, $\langle -1, 0, 0, 1 \rangle$, $\langle 0, 0, 0 \rangle$, $\langle 0, -1, 0 \rangle$	-	-
SUM_WIDTH_INCREASING_TERRACE	2, $\langle -1, 0, 0, 1 \rangle$, $\langle 0, 0, 0 \rangle$, $\langle 0, -2, 0 \rangle$	-	-
SUM_SURF_INCREASING_TERRACE	2, $\langle -2, -1, -1, 2 \rangle$, $\langle 0, 0, 0 \rangle$, $\langle 0, 2, 0 \rangle$	2, $\langle -2, -1, -1, 2 \rangle$, $\langle 0, 0, 0 \rangle$, $\langle 0, 2, 0 \rangle$	-
SUM_HEIGHT_INCREASING_TERRACE	2, $\langle -2, -1, -1, 2 \rangle$, $\langle 0, 0, 0 \rangle$, $\langle 0, 1, 0 \rangle$	2, $\langle -2, -1, -1, 2 \rangle$, $\langle 0, 0, 0 \rangle$, $\langle 0, 1, 0 \rangle$	-
NB_PEAK	2, $\langle -1, 1, 1, 0 \rangle$, $\langle 0, 0, 0 \rangle$, $\langle 0, -1, 0 \rangle$	-	-
SUM_WIDTH_PEAK	2, $\langle -1, 0, 1, 0 \rangle$, $\langle 0, 0, 0 \rangle$, $\langle 0, -1, 0 \rangle$	-	-
SUM_SURF_PEAK	2, $\langle -2, -1, 1, -2 \rangle$, $\langle 0, 0, 0 \rangle$, $\langle 0, 1, 0 \rangle$	3, $\langle -5, -4, -5, 4 \rangle$, $\langle -4, 0 \rangle$, $\langle 0, 0 \rangle$	-
SUM_MAX_PEAK	2, $\langle -1, 1, 1, 0 \rangle$, $\langle 0, 0, 0 \rangle$, $\langle 0, -1, 0 \rangle$	3, $\langle -5, -4, -5, 4 \rangle$, $\langle -4, 0 \rangle$, $\langle 0, 0 \rangle$	-

constraint	(4)	(5)	(6)
NB_PLAIN	2, (0, -2, -2, 1), (0, 0, 0), (0, -1, 0)	-	-
SUM_WIDTH_PLAIN	2, (0, -2, -2, 1), (0, 0, 0), (0, -2, 0)	-	-
SUM_SURF_PLAIN	2, (0, -2, -2, 1), (0, 0, 0), (0, 4, 0)	3, (0, -1, 0), (-1), (0)	-
SUM_HEICHT_PLAIN	2, (0, -2, -2, 1), (0, 0, 0), (0, 2, 0)	3, (0, -1, 0), (-1), (0)	-
NB_PLATEAU	2, (-1, 1, 1, 0), (0, 0, 0), (0, -1, 0)	-	-
SUM_WIDTH_PLATEAU	2, (-1, 1, 1, 0), (0, 0, 0), (0, -2, 0)	-	-
SUM_SURF_PLATEAU	2, (-1, 1, 1, 0), (0, 0, 0), (0, -2, 0)	3, (-5, -4, -5, 4), (-4, 0), (0, 0)	-
SUM_HEICHT_PLATEAU	2, (-1, 1, 1, 0), (0, 0, 0), (0, -1, 0)	3, (-5, -4, -5, 4), (-4, 0), (0, 0)	-
NB_PROPER_PLAIN	2, (0, -2, -2, 1), (0, 0, 0), (0, -1, 0)	-	-
SUM_WIDTH_PROPER_PLAIN	2, (0, -2, -2, 1), (0, 0, 0), (0, -2, 0)	-	-
SUM_SURF_PROPER_PLAIN	2, (0, -2, -2, 1), (0, 0, 0), (0, 4, 0)	2, (0, -2, -2, 1), (0, 0, 0), (0, 4, 0)	-
SUM_HEICHT_PROPER_PLAIN	2, (0, -2, -2, 1), (0, 0, 0), (0, 2, 0)	2, (0, -2, -2, 1), (0, 0, 0), (0, 2, 0)	-
NB_PROPER_PLATEAU	2, (-1, 1, 1, 0), (0, 0, 0), (0, -1, 0)	-	-
SUM_WIDTH_PROPER_PLATEAU	2, (-1, 1, 1, 0), (0, 0, 0), (0, -2, 0)	-	-
SUM_SURF_PROPER_PLATEAU	2, (-1, 1, 1, 0), (0, 0, 0), (0, -2, 0)	2, (-2, -1, -1, -3, 3), (0, 0, 0, 0), (0, 2, 0, 0)	-
SUM_HEICHT_PROPER_PLATEAU	2, (-1, 1, 1, 0), (0, 0, 0), (0, -1, 0)	2, (-2, -1, -1, -3, 3), (0, 0, 0, 0), (0, 1, 0, 0)	-
NB_STEADY_SEQUENCE	-	-	-
SUM_WIDTH_STEADY_SEQUENCE	-	-	-
SUM_SURF_STEADY_SEQUENCE	-	2, (-1, -1, 1), (-2, 0), (0, 0)	-
SUM_HEICHT_STEADY_SEQUENCE	-	2, (-1, -1, 1), (-1, 0), (0, 0)	-
NB_STRICTLY DECREASING_SEQUENCE	-	-	-
SUM_WIDTH_STRICTLY DECREASING_SEQUENCE	-	-	-
SUM_SURF_STRICTLY DECREASING_SEQUENCE	-	2, (-1, 0, -1), (0, -1), (0, 0)	-
SUM_MAX_STRICTLY DECREASING_SEQUENCE	-	2, (-2, -3, 2), (-2, 0), (0, 0)	-
SUM_MIN_STRICTLY DECREASING_SEQUENCE	-	2, (-1, 0, -1), (0, -1), (0, 0)	-
NB_STRICTLY INCREASING_SEQUENCE	-	-	-
SUM_WIDTH_STRICTLY INCREASING_SEQUENCE	-	-	-
SUM_SURF_STRICTLY INCREASING_SEQUENCE	-	2, (-2, -2, 1), (0, -1), (0, 0)	-
SUM_MAX_STRICTLY INCREASING_SEQUENCE	-	2, (-2, -1, 1), (-1, 1), (0, 1)	-
SUM_MIN_STRICTLY INCREASING_SEQUENCE	-	2, (-1, -1, 1), (0, -1), (0, 0)	-
NB_SUMMIT	-	-	-
SUM_WIDTH_SUMMIT	2, (-1, 0, 1, 0), (0, 0, 0), (0, -1, 0)	-	-
SUM_SURF_SUMMIT	2, (-2, -1, 1, -2), (0, 0, 0), (0, 1, 0)	3, (-5, -4, -5, 4), (-4, 0), (0, 0)	-
SUM_MAX_SUMMIT	-	3, (-5, -4, -5, 4), (-4, 0), (0, 0)	-
NB_VALLEY	2, (0, -2, -2, 1), (0, 0, 0), (0, -1, 0)	-	-
SUM_WIDTH_VALLEY	2, (0, -1, 0, 1), (0, 0, 0), (0, -1, 0)	-	-
SUM_SURF_VALLEY	2, (-3, -4, 2, 3), (0, 0, 0), (0, -2, 0)	3, (0, -1, 0), (-1), (0)	-
SUM_MIN_VALLEY	2, (0, -2, -2, 1), (0, 0, 0), (0, 2, 0)	3, (0, -1, 0), (-1), (0)	-
NB_ZICZAC	2, (-1, 0, -1, 0), (0, 0, 0), (0, -1, 0)	3, (-1, 0, -1, 0, -1), (0, 0, 0), (0, 1, 0)	-
SUM_WIDTH_ZICZAC	2, (-1, 0, -1, 0), (0, 0, 0), (0, -2, 0)	3, (-1, 0, -1, 0, -1), (0, 0, 0), (0, 1, 0)	-
SUM_SURF_ZICZAC	2, (-1, 0, -1, 0), (0, 0, 0), (0, 1, 0)	2, (-1, 0, -1, 0), (0, 0, 0), (0, 1, 0)	-
SUM_MAX_ZICZAC	2, (-5, -4, -5, 4), (0, 0, 0), (0, 4, 0)	2, (-5, -4, -5, 4), (0, 0, 0), (0, 4, 0)	4, (-1, 1, -1, 0, -1, 1, -1), (1, 0, 0, 1), (1, 1, 1, 1)
SUM_MIN_ZICZAC	2, (-1, 0, -1, 0), (0, 0, 0), (0, 1, 0)	2, (-1, 0, -1, 0), (0, 0, 0), (0, 1, 0)	4, (1, -3, 2, -1, 0, -2, 1), (-3, -1, -1, -2), (-3, -2, -2, -2)

C Evaluating Pattern Properties

This appendix provides the program that computes all the representatives of a pattern and the program that evaluates the properties of a pattern. Both programs (i) convert regular expression formulas of this paper in a sequence of operations on finite automata, and (ii) check that the final automaton contains or not an accepting state.

```
% Purpose: Compute the set of representative triple of a pattern and the properties of a pattern
% Author: Nicolas Beldiceanu, IMT Atlantique
:- use_module(dfa_aux_appendixC).

% generate all types used to generate the representative triples (see Figure 3) of the reversible
% patterns of Table 1 who have the single letter property
% | ? top.
% decreasing_terrace-[out,out,out],[out,out,in],[in,out,out]
% increasing_terrace-[out,out,out],[out,out,in],[in,out,out]
% plain-[out,out,out],[out,out,in],[in,out,out]
% plateau-[out,out,out],[out,out,in],[in,out,out]
% proper_plain-[out,out,out],[out,out,in],[in,out,out]
% proper_plateau-[out,out,out],[out,out,in],[in,out,out]
% gorge-[out,out,suf],[out,out,in],[pre,out,out],[pre,fac,suf],
% [pre,pre,in],[in,out,out],[in,suf,suf],[in,in,in]
% summit-[out,out,suf],[out,out,in],[pre,out,out],[pre,fac,suf],
% [pre,pre,in],[in,out,out],[in,suf,suf],[in,in,in]
% peak-[out,out,out],[out,out,suf],[out,out,in],[pre,out,out],
% [pre,fac,suf],[pre,pre,in],[in,out,out],[in,suf,suf],[in,in,in]
% valley-[out,out,out],[out,out,suf],[out,out,in],[pre,out,out],
% [pre,fac,suf],[pre,pre,in],[in,out,out],[in,suf,suf],[in,in,in]
% decreasing_sequence-[pre,out,suf],[pre,fac,suf],[pre,pre,in],[in,suf,suf],[in,in,in]
% increasing_sequence-[pre,out,suf],[pre,fac,suf],[pre,pre,in],[in,suf,suf],[in,in,in]
% steady_sequence-[in,in,in]
% strictly_decreasing_sequence-[in,in,in]
% strictly_increasing_sequence-[in,in,in]
% zigzag-[out,out,out],[out,out,in],[in,out,out],[in,out,in],[in,in,in]
top :-
    member(Pattern, [decreasing_terrace,
                    increasing_terrace,
                    plain,
                    plateau,
                    proper_plain,
                    proper_plateau,
                    gorge,
                    summit,
                    peak,
                    valley,
                    decreasing_sequence,
                    increasing_sequence,
                    steady_sequence,
                    strictly_decreasing_sequence,
                    strictly_increasing_sequence,
                    zigzag]),
    reg_exp(Pattern, LPattern),
    findall(Triple, gen_potential_word_types(LPattern, Triple), Triples),
    write(Pattern-Triples), nl, fail.

gen_potential_word_types(LPattern, Triple) :- % DEFINITION 9
    Triple = [T1, T2, T3],
    PotentialLanguages = [out, fac, pre, suf, in],
    member(T1, PotentialLanguages),
    member(T2, PotentialLanguages),
    member(T3, PotentialLanguages),
    word_language(T1, LPattern, L1),
    word_language(T2, LPattern, L2),
    word_language(T3, LPattern, L3),
```

```

word_type_language(L1, L2, L3, LPattern, LResult),
regex_kernel(LResult, Automaton),
(Automaton = kernel([],[]) -> fail ; true).

% language of a word
word_language(out, LPattern, Out) :- % DEFINITION 9
    LEG = {[l],[e],[g]},
    SigmaStar = *(LEG),
    SigmaPlus = (LEG + SigmaStar),
    Out = (SigmaPlus \ (SigmaStar + LPattern + SigmaStar)).
word_language(fac, LPattern, Fac) :- % DEFINITION 9
    LEG = {[l],[e],[g]},
    SigmaStar = *(LEG),
    SigmaPlus = (LEG + SigmaStar),
    Fac = (SigmaPlus + LPattern + SigmaPlus) /\
           (SigmaStar\LPattern + SigmaPlus) /\
           (SigmaStar\LPattern + SigmaPlus) /\
           (SigmaStar\LPattern).
word_language(pre, LPattern, Pre) :- % DEFINITION 9
    LEG = {[l],[e],[g]},
    SigmaStar = *(LEG),
    SigmaPlus = (LEG + SigmaStar),
    Pre = (LPattern + SigmaPlus) /\
           (SigmaStar\SigmaPlus + LPattern) /\
           (SigmaStar\LPattern).
word_language(suf, LPattern, Suf) :- % DEFINITION 9
    LEG = {[l],[e],[g]},
    SigmaStar = *(LEG),
    SigmaPlus = (LEG + SigmaStar),
    Suf = (SigmaPlus + LPattern) /\
           (SigmaStar\LPattern + SigmaPlus) /\
           (SigmaStar\LPattern).
word_language(in, LPattern, In) :- % DEFINITION 9
    LEG = {[l],[e],[g]},
    SigmaStar = *(LEG),
    In = (LPattern + SigmaStar) /\
         (SigmaStar + LPattern).

word_type_language(L1, L2, L3, LPattern, LResult) :- % DEFINITION 10 and THEOREM 2
    LEG = {[l],[e],[g]},
    SigmaStar = *(LEG),
    SigmaPlus = (LEG + SigmaStar),
    Tempo1 = shuffle(shuffle(LPattern,s),s),
    Tempo2 = (shuffle(L1,s) + [s] + SigmaStar),
    Tempo3 = ((SigmaStar + [s] + L2 + [s] + SigmaPlus) \\/ (SigmaPlus + [s] + L2 + [s] + SigmaStar)),
    Tempo4 = (SigmaStar + [s] + shuffle(L3,s)),
    LResult = (Tempo1 /\ Tempo2 /\ Tempo3 /\ Tempo4).

% check pattern properties shown in Table 1 and in Examples 4 and 9
% | ?- try(convex).
% convex(bump_on_decreasing_sequence)
% convex(decreasing)
% convex(decreasing_sequence)
% convex(decreasing_terrace)
% convex(dip_on_increasing_sequence)
% convex(gorge)
% convex(increasing)
% convex(increasing_sequence)
% convex(increasing_terrace)
% convex(inflexion)
% convex(peak)
% convex(plain)
% convex(plateau)
% convex(proper_plain)
% convex(proper_plateau)
% convex(steady)
% convex(steady_sequence)
% convex(strictly_decreasing_sequence)

```

```

% convex(strictly_increasing_sequence)
% convex(summit)
% convex(valley)
% convex(zigzag)
try(convex) :-
    reg_exp(Pattern, LPattern),
    (convex(LPattern) -> write(convex(Pattern)), nl ; true),
    fail.
% | ?- try(no_inflexion).
% no_inflexion(decreasing)
% no_inflexion(decreasing_sequence)
% no_inflexion(decreasing_terrace)
% no_inflexion(increasing)
% no_inflexion(increasing_sequence)
% no_inflexion(increasing_terrace)
% no_inflexion(steady)
% no_inflexion(steady_sequence)
% no_inflexion(strictly_decreasing_sequence)
% no_inflexion(strictly_increasing_sequence)
try(no_inflexion) :-
    reg_exp(Pattern, LPattern),
    (no_inflexion(LPattern) -> write(no_inflexion(Pattern)), nl ; true),
    fail.
% | ?- try(one_inflexion).
% one_inflexion(gorge)
% one_inflexion(inflexion)
% one_inflexion(peak)
% one_inflexion(plain)
% one_inflexion(plateau)
% one_inflexion(proper_plain)
% one_inflexion(proper_plateau)
% one_inflexion(summit)
% one_inflexion(valley)
try(one_inflexion) :-
    reg_exp(Pattern, LPattern),
    (one_inflexion(LPattern) -> write(one_inflexion(Pattern)), nl ; true),
    fail.
% | ?- try(single_letter).
% single_letter(decreasing)
% single_letter(increasing)
% single_letter(steady)
try(single_letter) :-
    reg_exp(Pattern, LPattern),
    (single_letter(LPattern) -> write(single_letter(Pattern)), nl ; true),
    fail.
% | ?- try(exclude_out_in).
% exclude_out_in(decreasing)
% exclude_out_in(decreasing_sequence)
% exclude_out_in(increasing)
% exclude_out_in(increasing_sequence)
% exclude_out_in(steady)
% exclude_out_in(steady_sequence)
% exclude_out_in(strictly_decreasing_sequence)
% exclude_out_in(strictly_increasing_sequence)
try(exclude_out_in) :-
    reg_exp(Pattern, LPattern),
    (exclude_out_in(LPattern) -> write(exclude_out_in(Pattern)), nl ; true),
    fail.
% | ?- try(letter).
% letter(decreasing,g)
% letter(decreasing_sequence,g)
% letter(increasing,l)
% letter(increasing_sequence,l)
% letter(steady,e)
% letter(steady_sequence,e)
% letter(strictly_decreasing_sequence,g)
% letter(strictly_increasing_sequence,l)
try(letter) :-

```



```

        reg_exp(Pattern, LPattern),
        member(Letter, [l,e,g]),
        (letter(LPattern, Letter) -> write(letter(Pattern,Letter)), nl ; true),
        fail.
% | ?- try(suffix_unavoidable).
% suffix_unavoidable(decreasing,g)
% suffix_unavoidable(decreasing_sequence,g)
% suffix_unavoidable(gorge,g)
% suffix_unavoidable(increasing,l)
% suffix_unavoidable(increasing_sequence,l)
% suffix_unavoidable(peak,l)
% suffix_unavoidable(plain,g)
% suffix_unavoidable(plateau,l)
% suffix_unavoidable(proper_plain,g)
% suffix_unavoidable(proper_plateau,l)
% suffix_unavoidable(steady,e)
% suffix_unavoidable(steady_sequence,e)
% suffix_unavoidable(strictly_decreasing_sequence,g)
% suffix_unavoidable(strictly_increasing_sequence,l)
% suffix_unavoidable(summit,l)
% suffix_unavoidable(valley,g)
try(suffix_unavoidable) :-                                % DEFINITION 21
    reg_exp(Pattern, LPattern),
    member(Letter, [l,e,g]),
    (suffix_unavoidable(LPattern, Letter) -> write(suffix_unavoidable(Pattern,Letter)), nl ; true),
    fail.
% | ?- try(incompressible).
% incompressible(bump_on_decreasing_sequence)
% incompressible(decreasing)
% incompressible(decreasing_terrace)
% incompressible(dip_on_increasing_sequence)
% incompressible(increasing)
% incompressible(increasing_terrace)
% incompressible(plain)
% incompressible(plateau)
% incompressible(proper_plain)
% incompressible(proper_plateau)
% incompressible(steady)
try(incompressible) :-                                    % DEFINITION 22
    reg_exp(Pattern, LPattern),
    (incompressible(LPattern) -> write(incompressible(Pattern)), nl ; true),
    fail.
% | ?- try(factor).
% factor(bump_on_decreasing_sequence,5)
% factor(decreasing,1)
% factor(dip_on_increasing_sequence,5)
% factor(increasing,1)
% factor(steady,1)
% factor(steady_sequence,1)
% factor(strictly_decreasing_sequence,1)
% factor(strictly_increasing_sequence,1)
% factor(zigzag,3)
try(factor) :-                                          % DEFINITION 23
    reg_exp(Pattern, LPattern),
    pattern_smallest_size(Pattern, Minl),
    (factor(LPattern, Minl) -> write(factor(Pattern,Minl)), nl ; true),
    fail.
convex(LPattern) :-                                     % DEFINITION 3
    LEG      = {[l],[e],[g]},
    SigmaStar = *(LEG),
    SigmaPlus = (LEG + SigmaStar),
    L1       = (shuffle(shuffle(LPattern,s),s),s) /\
                (SigmaStar + [s] + LPattern + SigmaStar + LPattern + [s] + SigmaStar) /\
                (SigmaStar + [s] + (SigmaPlus*LPattern) + [s] + SigmaStar)),
    L2       = (shuffle(shuffle(shuffle(shuffle(LPattern,s),s),s),s),s) /\
                (SigmaStar + [s] + shuffle(LPattern,s) + [s] + SigmaPlus + [s] + SigmaStar) /\
                (SigmaStar + [s] + SigmaPlus + [s] + shuffle(LPattern,s) + [s] + SigmaStar) /\

```

```

        (SigmaStar + [s] + shuffle(shuffle(SigmaPlus\LPattern,s),s) + [s] + SigmaStar)),
    regex_kernel(L1, Automaton1),
    regex_kernel(L2, Automaton2),
    Automaton1 = kernel([], []),
    Automaton2 = kernel([], []).

no_inflexion(LPATTERN) :-                                     % DEFINITION 4
    LEG = {[l],[e],[g]},
    SigmaStar = *(LEG),
    L = (LPATTERN /\ (SigmaStar + [l] + SigmaStar + [g] + SigmaStar)) \/
        (LPATTERN /\ (SigmaStar + [g] + SigmaStar + [l] + SigmaStar)),
    regex_kernel(L, Automaton),
    Automaton = kernel([], []).

one_inflexion(LPATTERN) :-                                   % DEFINITION 5
    Inf1 = (*( [l] \/ [e] ) + [l] + *( [e] ) + [g] + *( [g] \/ [e] )),
    Inf2 = (*( [g] \/ [e] ) + [g] + *( [e] ) + [l] + *( [l] \/ [e] )),
    L = (LPATTERN \ (Inf1 \/ Inf2)),
    regex_kernel(L, Automaton),
    Automaton = kernel([], []).

single_letter(LPATTERN) :-                                  % DEFINITION 6
    LEG = {[l],[e],[g]},
    L = LPATTERN \ LEG,
    regex_kernel(L, Automaton),
    Automaton = kernel([], []).

exclude_out_in(LPATTERN) :-                                 % DEFINITION 7
    LEG = {[l],[e],[g]},
    SigmaStar = *(LEG),
    SigmaPlus = (LEG + SigmaStar),
    L1 = (shuffle(shuffle(shuffle(shuffle(LPATTERN,s),s),s),s) /\
        (SigmaStar + [s] + SigmaPlus + [s] + shuffle(SigmaPlus\
        (SigmaStar+LPATTERN+SigmaStar),s) + [s] + SigmaStar) /\
        (SigmaStar + [s] + shuffle(LPATTERN,s) + [s] + SigmaStar + [s] + SigmaStar) /\
        (SigmaStar + [s] + SigmaPlus + [s] + SigmaPlus + [s] + SigmaStar + [s] + SigmaStar))),
    L2 = (shuffle(shuffle(shuffle(shuffle(LPATTERN,s),s),s),s) /\
        (SigmaStar + [s] + shuffle(SigmaPlus\
        (SigmaStar+LPATTERN+SigmaStar),s) + [s] + SigmaPlus + [s] + SigmaStar) /\
        (SigmaStar + [s] + SigmaStar + [s] + shuffle(LPATTERN,s) + [s] + SigmaStar) /\
        (SigmaStar + [s] + SigmaStar + [s] + SigmaPlus + [s] + SigmaPlus + [s] + SigmaStar))),
    regex_kernel(L1, Automaton1),
    regex_kernel(L2, Automaton2),
    Automaton1 = kernel([], []),
    Automaton2 = kernel([], []).

letter(LPATTERN, Letter) :-                                 % DEFINITION 20
    LEG = {[l],[e],[g]},
    L1 = (*(LEG\[Letter])) /\ LPATTERN,
    L2 = [Letter] /\ LPATTERN,
    regex_kernel(L1, Automaton1),
    regex_kernel(L2, Automaton2),
    Automaton1 = kernel([], []),
    (Automaton2 = kernel([], []) -> fail ; true).

suffix_unavoidable(LPATTERN, Letter) :-                    % DEFINITION 21
    LEG = {[l],[e],[g]},
    SigmaStar = *(LEG),
    L1 = (*(LEG\[Letter])) /\ LPATTERN,
    L2 = (shuffle(LPATTERN,s) /\
        (SigmaStar + [s] + [Letter] + SigmaStar) /\
        (SigmaStar + [s] + (SigmaStar\LPATTERN))),
    regex_kernel(L1, Automaton1),
    regex_kernel(L2, Automaton2),
    Automaton1 = kernel([], []),
    Automaton2 = kernel([], []).

incompressible(LPATTERN) :-                                 % DEFINITION 22
    LEG = {[l],[e],[g]},
    SigmaStar = *(LEG),

```

```

SigmaPlus = (LEG + SigmaStar),
L          = ((SigmaPlus + LPattern + SigmaStar) /\ LPattern) \/
             ((SigmaStar + LPattern + SigmaPlus) /\ LPattern),
regex_kernel(L, Automaton),
Automaton = kernel([],[]).

factor(LPattern, Minl) :-                                     % DEFINITION 23
LEG        = {[l],[e],[g]},
SigmaStar  = *(LEG),
(Minl = 1 -> SigmaMinl = LEG                                ;
 Minl = 2 -> SigmaMinl = LEG+LEG                            ;
 Minl = 3 -> SigmaMinl = LEG+LEG+LEG                        ;
 Minl = 4 -> SigmaMinl = LEG+LEG+LEG+LEG                    ;
 Minl = 5 -> SigmaMinl = LEG+LEG+LEG+LEG+LEG                ;
 write(minl_no_implemented(Minl)), nl, false),
L = (shuffle(shuffle(LPattern,s),s)                         /\
     (SigmaStar + [s] + SigmaStar + SigmaMinl + SigmaStar + [s] + SigmaStar) /\
     (SigmaStar + [s] + (SigmaStar\LPattern) + [s] + SigmaStar)),
regex_kernel(L, Automaton),
Automaton = kernel([],[]).

% reg_exp(pattern, reg_exp): l for <, e for =, g for >
reg_exp(bump_on_decreasing_sequence, [l,l,g,l,l]).          % <<><<
reg_exp(decreasing, [g]).                                    % >
reg_exp(decreasing_sequence, (([g] + *([g] \/ [e]) + [g]) \/ [g])). % > (>|=)* > | >
reg_exp(decreasing_terrace, ([g] + [e] + *([e]) + [g])). % > += >
reg_exp(dip_on_increasing_sequence, [g,g,l,g,g]).          % >><>>
reg_exp(gorge, (([g]\([g]+ *([e]\[g])+[g]))+([l]\([l]+ *([e]\[l])+[l])))). % (>|(>|=)* >)|(<|=)*(<|<))
reg_exp(increasing, [l]).                                    % <
reg_exp(increasing_sequence, (([l] + *([l] \/ [e]) + [l]) \/ [l])). % < (<|=)* < | <
reg_exp(increasing_terrace, ([l] + [e] + *([e]) + [l])). % < += <
reg_exp(inflexion, (([l] + *([l]\[e])+[g])\([g]+ *([g]\[e])+[l])))). % < (<|=)* > | > (>|=)* <
reg_exp(peak, ([l] + *([e] \/ [l]) + *([g] \/ [e]) + [g])). % < (<|=)* (>|=)* >
reg_exp(plain, ([g] + *([e]) + [l])).                       % > =* <
reg_exp(plateau, ([l] + *([e]) + [g])).                    % < =* >
reg_exp(proper_plain, ([g] + [e] + *([e]) + [l])).        % > += <
reg_exp(proper_plateau, ([l] + [e] + *([e]) + [g])).      % < += >
reg_exp(steady, [e]).                                       % =
reg_exp(steady_sequence, ([e] + *([e]))).                 % +=
reg_exp(strictly_decreasing_sequence, ([g] + *([g]))).    % >+
reg_exp(strictly_increasing_sequence, ([l] + *([l]))).    % <+
reg_exp(summit, (([l]\([l]+ *([e]\[l])+[l]))+([g]\([g]+ *([e]\[g])+[g])))). % (<|(<|=)*(<|<))(>|(>|=)*>))
reg_exp(valley, ([g] + *([e] \/ [g]) + *([l] \/ [e]) + [l])). % > (= | >)* (< | =)* <
reg_exp(zigzag, ((*([l,g])+([l,g])+([l]\[l,g])))\(*([g,l])+([g,l])+([g]\[g,l])))). % (<>+ (<|<)| (>|>+ (>|><))

pattern_smallest_size(bump_on_decreasing_sequence, 5) :- !.
pattern_smallest_size(decreasing, 1) :- !.
pattern_smallest_size(decreasing_sequence, 1) :- !.
pattern_smallest_size(decreasing_terrace, 3) :- !.
pattern_smallest_size(dip_on_increasing_sequence, 5) :- !.
pattern_smallest_size(gorge, 2) :- !.
pattern_smallest_size(increasing, 1) :- !.
pattern_smallest_size(increasing_sequence, 1) :- !.
pattern_smallest_size(increasing_terrace, 3) :- !.
pattern_smallest_size(inflexion, 2) :- !.
pattern_smallest_size(peak, 2) :- !.
pattern_smallest_size(plain, 2) :- !.
pattern_smallest_size(plateau, 2) :- !.
pattern_smallest_size(proper_plain, 3) :- !.
pattern_smallest_size(proper_plateau, 3) :- !.
pattern_smallest_size(steady, 1) :- !.
pattern_smallest_size(steady_sequence, 1) :- !.
pattern_smallest_size(strictly_decreasing_sequence, 1) :- !.
pattern_smallest_size(strictly_increasing_sequence, 1) :- !.
pattern_smallest_size(summit, 2) :- !.
pattern_smallest_size(valley, 2) :- !.
pattern_smallest_size(zigzag, 3) :- !.
pattern_smallest_size(P, _) :- write(not_implemented(P)), nl, false.

```

```

% Purpose: Some operations on plain DFA i.e. no registers, no guards
% Author: Mats Carlsson, RISE

:- module(dfa_aux_appendixC, [
    regex_kernel/2,
    kernel_closure/2,
    kernel_intersection/3,
    kernel_union/3,
    kernel_difference/3,
    kernel_concatenation/3,
    kernel_shuffle/3,
    kernel_normalize/2,
    kernel_string/2,
    kernel_print_dot/1
]).

:- use_module(library(lists)).
:- use_module(library(ordsets)).
:- use_module(library(avl)).
:- use_module(library(ugraphs)).

/****
EXPORTED PREDICATES:

%% Kernel ::=      kernel(SourcesSinks,Arcs)

%% where Alphabet should be a plain Prolog list

%% Regex ::=      [w,o,r,d] // plain Prolog list of atomic symbols
%%                | {Regex,Regex,...} // union over set of regex
%%                | *(Regex) // Kleene star
%%                | (Regex /\ Regex) // intersection
%%                | (Regex \/ Regex) // union
%%                | (Regex \ Regex) // difference
%%                | (Regex + Regex) // concatenation
%%                | shuffle(Regex,S) // L(Regex) with the symbol S inserted once, somewhere
%%                | truncate(Regex,1) // the set of strings of L(Regex) truncated to length at most one
%%                | tail(Regex,1) // the set of strings of L(Regex) truncated to tails of length at most one
%%                | prefix(Regex) // the set of prefixes of L(Regex)
%%                | suffix(Regex) // the set of suffixes of L(Regex)

%. regex_kernel(+Rregex, -Kernel)
%%
%% Computes the normalized kernel that recognizes Rregex.

%. kernel_closure(+Kernel, -Closure)
%%
%% Computes the Kleene closure of a kernel.

%. kernel_intersection(+Kernel1, +Kernel2, -Intersection)
%%
%% Computes the intersection of two kernels.

%. kernel_union(+Kernel1, +Kernel2, -Union)
%%
%% Computes the union of two kernels.

%. kernel_difference(+Kernel1, +Kernel2, -Difference)
%%
%% Computes the difference of two kernels.

%. kernel_concatenation(+Kernel1, +Kernel2, -Concatenation)
%%
%% Computes the concatenation of two kernels.

%. kernel_shuffle(+Kernel, +Symbol, -Insertion)
%%

```

```

%% Computes the kernel corresponding to shuffle(...,Symbol)

%. kernel_truncate(+Kernel, +N, -Truncation)
%%
%% Computes the kernel corresponding to truncate(...,N)

%. kernel_tail(+Kernel, +N, -Tail)
%%
%% Computes the kernel corresponding to tail(...,N)

%. kernel_prefix(+Kernel, -Prefix)
%%
%% Computes the kernel corresponding to prefix(...)

%. kernel_suffix(+Kernel, -Suffix)
%%
%% Computes the kernel corresponding to suffix(...)

%. kernel_normalize(+Kernel1, -Kernel2)
%%
%% Makes a kernel determinate if need be, and minimize it.

%. kernel_print_dot(+Kernel)
%%
%% Prints a kernel as a digraph in the dot language.

%. kernel_string(+Kernel, -String)
%%
%% Generate a string that the kernel recognizes. Enumerate all strings on backtracking.
%% N.B. Kernel must be normalized.
***/

regex_kernel(Regexp, Kernel) :-
    empty_avl(AVL),
    regex_kernel(Regexp, Kernel, AVL, _).
regex_kernel(Regexp, Kernel, AVLO, AVL) :-
    avl_fetch(Regexp, AVLO, Kernel), !,
    AVL = AVLO.
regex_kernel(Regexp, Kernel, AVLO, AVL) :-
    regex_kernel_rec(Regexp, Kernel0, AVLO, AVL1),
    kernel_normalize(Kernel0, Kernel),
    avl_store(Regexp, AVL1, Kernel, AVL).

regex_kernel_rec((R1\|R2), Kernel) --> !,
    regex_kernel(R1, K1),
    regex_kernel(R2, K2),
    {kernel_union(K1, K2, Kernel)}.
regex_kernel_rec((R1/R2), Kernel) --> !,
    regex_kernel(R1, K1),
    regex_kernel(R2, K2),
    {kernel_intersection(K1, K2, Kernel)}.
regex_kernel_rec((R1\R2), Kernel) --> !,
    regex_kernel(R1, K1),
    regex_kernel(R2, K2),
    {kernel_difference(K1, K2, Kernel)}.
regex_kernel_rec(*(R1), Kernel) --> !,
    regex_kernel(R1, K1),
    {kernel_closure(K1, Kernel)}.
regex_kernel_rec((R1+R2), Kernel) --> !,
    regex_kernel(R1, K1),
    regex_kernel(R2, K2),
    {kernel_concatenation(K1, K2, Kernel)}.
regex_kernel_rec(shuffle(R1,S), Kernel) --> !,
    regex_kernel(R1, K1),
    {kernel_shuffle(K1, S, Kernel)}.
regex_kernel_rec(truncate(R1,1), Kernel) --> !,
    regex_kernel(R1, K1),
    {kernel_truncate(K1, 1, Kernel)}.

```

```

regex_kernel_rec(tail(R1,1), Kernel) --> !,
    regex_kernel(R1, K1),
    {kernel_tail(K1, 1, Kernel)}.
regex_kernel_rec(prefix(R1), Kernel) --> !,
    regex_kernel(R1, K1),
    {kernel_prefix(K1, Kernel)}.
regex_kernel_rec(suffix(R1), Kernel) --> !,
    regex_kernel(R1, K1),
    {kernel_suffix(K1, Kernel)}.
regex_kernel_rec({}, Kernel) --> !,
    regex_kernel([], Kernel).
regex_kernel_rec({Tree}, Kernel) --> !,
    {orify(Tree, Regexp)},
    regex_kernel(Regexp, Kernel).
regex_kernel_rec(String, Kernel) -->
    {length(String, _)}, !,
    {Kernel = kernel([source(S1),sink(S4)], Arcs)},
    (
        foreach(A,String),
        foreach(arc(S2,A,S3),Arcs),
        fromto(S1,S2,S3,S4)
    do []
    ).

orify(X,Y), (R\S) :- !,
    orify(X, R),
    orify(Y, S).
orify(X, X).

kernel_closure(Kernel1, Closure) :-
    kernel_parts(Kernel1, Sources, Sinks, _, Arcs, _),
    tag_sources_sinks(Sources, Sources, Sinks1, Sources1),
    tag_sources_sinks([], Sinks, [], Sinks2),
    ord_union([Sinks1, Sinks2, Sources1], SS3),
    (
        foreach(arc(Q3,A,Q4),Arcs),
        fromto(Arcs1,Arcs2,Arcs6,[]),
        param(Sinks,Sources)
    do (
        ord_member(Q4, Sinks)
        -> Arcs5 = [arc(Q3,A,Q4)|Arcs6],
            (
                foreach(Q5,Sources),
                fromto(Arcs2,Arcs3,Arcs4,Arcs5),
                param(Q3,A)
            do Arcs3 = [arc(Q3,A,Q5)|Arcs4]
            )
        ; Arcs2 = [arc(Q3,A,Q4)|Arcs6]
    )
    ),
    Closure = kernel(SS3,Arcs1).

kernel_complement(Kernel1, Complement) :-
    kernel_parts(Kernel1, Sources, Sinks, States, Arcs, _),
    Complement = kernel(SourcesSinks2,Arcs),
    ord_subtract(States, Sinks, NotSinks),
    tag_sources_sinks(Sources, NotSinks, Sources2, Sinks2),
    append(Sources2, Sinks2, SourcesSinks2).

kernel_intersection(Kernel1, Kernel2, Intersection) :-
    Intersection = kernel(SourcesSinks3,Arcs3),
    kernel_parts(Kernel1, Sources1, Sinks1, _, Arcs1, _),
    kernel_parts(Kernel2, Sources2, Sinks2, _, Arcs2, _),
    pairs(Sources1, Sources2, Sources3, []),
    closure(Sources3, Sources3, Closure, Arcs1, Arcs2, Arcs3, []),
    pairs(Sinks1, Sinks2, Sinks3, []),
    ord_intersection(Sinks3, Closure, Sinks3c),
    tag_sources_sinks(Sources3, Sinks3c, SS1, SS2),
    append(SS1, SS2, SourcesSinks3).

kernel_union(Kernel1, Kernel2, Union) :-
    kernel_parts(Kernel1, Sources1, Sinks1, _, Arcs1, _),

```

```

kernel_parts(Kernel2, Sources2, Sinks2, _, Arcs2, _),
append(Sources1, Sources2, Sources12),
append(Sinks1, Sinks2, Sinks12),
append(Arcs1, Arcs2, Arcs12),
tag_sources_sinks(Sources12, Sinks12, TSo12, TSi12),
append(TSo12, TSi12, SS12),
Union = kernel(SS12, Arcs12).

kernel_difference(Kernel1, Kernel2, Difference) :-
kernel_parts(Kernel1, _, _, _, Alpha1),
kernel_parts(Kernel2, Sources2, Sinks2, _, Arcs2, Alpha2),
tag_sources_sinks(Sources2, Sinks2, TSo2, TSi2),
append(TSo2, TSi2, SS2),
ord_union(Alpha1, Alpha2, Alpha3),
ord_subtract(Alpha3, Alpha2, ToAdd2),
( foreach(A2, ToAdd2),
  foreach(arc(_, A2, _), New2)
do true
),
append(Arcs2, New2, Arcs22),
kernel_complement(kernel(SS2, Arcs22), K2C),
kernel_intersection(Kernel1, K2C, Difference).

kernel_concatenation(Kernel1, Kernel2, Concat) :-
kernel_parts(Kernel1, Sources1, Sinks1, _, Arcs1, _),
kernel_parts(Kernel2, Sources2, Sinks2, _, Arcs2, _),
Concat = kernel(SS3, Arcs3),
tag_sources_sinks(Sources1, Sinks2, Sources3, Sinks3),
( foreach(arc(Q5, A5, R5), Arcs1),
  fromto(New3, New4, New7, []),
  param(Sinks1, Sources2)
do ( ord_nonmember(R5, Sinks1) -> New4 = New7
; ( foreach(So5, Sources2),
  fromto(New4, New5, New6, New7),
  param(Q5, A5)
do New5 = [arc(Q5, A5, So5) | New6]
)
),
( ord_disjoint(Sources1, Sinks1) -> Sources4 = []
; tag_sources_sinks(Sources2, [], Sources4, [])
),
append([Sources3, Sources4, Sinks3], SS3),
ord_union([Arcs1, Arcs2, New3], Arcs3).

kernel_shuffle(Kernel1, Symbol, Insertion) :-
kernel_parts(Kernel1, Sources1, _, States1, Arcs1, _),
kernel_parts(Kernel1, _, Sinks2, States2, Arcs2, _),
Insertion = kernel(SS3, Arcs3),
tag_sources_sinks(Sources1, Sinks2, Sources3, Sinks3),
( foreach(Q1, States1),
  foreach(Q2, States2),
  foreach(arc(Q1, Symbol, Q2), New3),
  param(Symbol)
do true
),
append(Sources3, Sinks3, SS3),
ord_union([Arcs1, Arcs2, New3], Arcs3).

kernel_truncate(Kernel1, 1, Truncation) :-
kernel_normalize(Kernel1, Kernel2), % precondition!
Kernel2 = kernel(SS2, Arcs2),
( Arcs2 = [] -> Truncation = Kernel2
; memberchk(source(Src), SS2),
( foreach(Arc, Arcs2),
  fromto(Arcs3, Arcs4, Arcs5, []),
  param(Src, Q3)
do Arc = arc(Q1, A, _),

```

```

        ( Q1==Src -> Arcs4 = [arc(Src,A,Q3)|Arcs5]
          ; Arcs4 = Arcs5
        )
    ),
    (memberchk(sink(Src), SS2) -> Sinks3 = [Src,Q3] ; Sinks3 = [Q3]),
    tag_sources_sinks([Src], Sinks3, TSS1, TSS2),
    append(TSS1, TSS2, TSS12),
    Truncation = kernel(TSS12,Arcs3)
).

kernel_tail(Kernel1, 1, Tail) :-
    kernel_normalize(Kernel1, Kernel2), % precondition!
    Kernel2 = kernel(SS2,Arcs2),
    ( Arcs2 = [] -> Tail = Kernel2
      ; memberchk(source(Src), SS2),
        ( foreach(Arc,Arcs2),
          fromto(Arcs3,Arcs4,Arcs5,[]),
          param(SS2,Src,Sink)
          do Arc = arc(_,A,Q),
            ( memberchk(sink(Q), SS2) -> Arcs4 = [arc(Src,A,Sink)|Arcs5]
              ; Arcs4 = Arcs5
            )
          ),
        (memberchk(sink(Src), SS2) -> Sources3 = [Src,Sink] ; Sources3 = [Src]),
        tag_sources_sinks(Sources3, [Sink], TSS1, TSS2),
        append(TSS1, TSS2, TSS12),
        Tail = kernel(TSS12,Arcs3)
    ).

%% make all states sinks, keeping sources
kernel_prefix(Kernel1, Prefix) :-
    Kernel1 = kernel(SS1,Arcs),
    ( foreach(SS,SS1),
      fromto(SS2,SS3,SS4,SS5)
    do (SS = source(_) -> SS3 = [SS|SS4] ; SS3 = SS4)
    ),
    ( foreach(arc(Q1,_,Q2),Arcs),
      fromto(SS5,SS6,SS7,[])
    do SS6 = [sink(Q1),sink(Q2)|SS7]
    ),
    sort(SS2, SS8),
    Prefix = kernel(SS8,Arcs).

%% make all states sources, keeping sinks
kernel_suffix(Kernel1, Suffix) :-
    Kernel1 = kernel(SS1,Arcs),
    ( foreach(SS,SS1),
      fromto(SS2,SS3,SS4,SS5)
    do (SS = sink(_) -> SS3 = [SS|SS4] ; SS3 = SS4)
    ),
    ( foreach(arc(Q1,_,Q2),Arcs),
      fromto(SS5,SS6,SS7,[])
    do SS6 = [source(Q1),source(Q2)|SS7]
    ),
    sort(SS2, SS8),
    Suffix = kernel(SS8,Arcs).

%% rename states to brand new variables
%% if need be, add extra "black hole" state
%% ensure that every combo <state,letter> has at least one transition
%% output Sources, Sinks, States, Arcs, Alphabet as ordered sets
kernel_parts(Kernel1, Sources, Sinks, States, Arcs, Alphabet) :-
    rename_states(Kernel1, Kernel2),
    Kernel2 = kernel(SourcesSinks,Arcs1),
    ( foreach(Item,SourcesSinks),
      fromto(Sources1,So1,So2,[]),
      fromto(Sinks1,Si1,Si2,[]),
      foreach(Y,Qs4)

```



```

do ( Item = source(Y) -> So1 = [Y|So2], Si1 = Si2
; Item = sink(Y) -> So1 = So2, Si1 = [Y|Si2]
)
),
sort(Sources1, Sources),
sort(Sinks1, Sinks),
sort(Arcs1, Arcs2),
( foreach(arc(Q1,A1,Q2),Arcs2),
  foreach(Q1*A1,Out1),
  foreach(A1,As),
  fromto(Qs1,Qs2,Qs3,Qs4)
do Qs2 = [Q1,Q2|Qs3]
),
sort(As, Alphabet),
sort(Qs1, States1),
sort(Out1, Out2),
pairs(States1, Alphabet, Out3, []),
ord_subtract(Out3, Out2, Out4),
( Out4 = [] -> Arcs = Arcs2, States = States1
; ( foreach(Q3*A3,Out4),
  foreach(arc(Q3,A3,Aux),Arcs3),
  param(Aux)
do true
),
( foreach(A4,Alphabet),
  foreach(arc(Aux,A4,Aux),Arcs4),
  param(Aux)
do true
),
ord_union([Arcs2,Arcs3,Arcs4], Arcs),
ord_add_element(States1, Aux, States)
).

rename_states(kernel(SourcesSinks1,Arcs1), kernel(SourcesSinks2,Arcs2)) :-
  rename_states(SourcesSinks1, SourcesSinks2, KL1, KL2),
  rename_states(Arcs1, Arcs2, KL2, []),
  keysort(KL1, KL3),
  keyclumped(KL3, KL4),
  ( foreach(_-Clump,KL4)
do ( foreach(X,Clump),
  param(X)
do true
)
).

rename_states(L1, L2) -->
( foreach(X,L1),
  foreach(Y,L2)
do ( {X = source(Q1)}
-> {Y = source(Q2)}, [Q1-Q2]
; {X = sink(Q1)}
-> {Y = sink(Q2)}, [Q1-Q2]
; {X = arc(Q1,A,Q3)}
-> {Y = arc(Q2,A,Q4)}, [Q1-Q2,Q3-Q4]
)
).

tag_sources_sinks(Sources, Sinks, SS1, SS2) :-
( foreach(Q1,Sources),
  foreach(source(Q1),SS1)
do true
),
( foreach(Q2,Sinks),
  foreach(sink(Q2),SS2)
do true
).

pairs(Xs, Ys) -->

```

```

    ( foreach(X,Xs),
      param(Ys)
    do ( foreach(Y,Ys),
        param(X)
        do [X*Y]
        )
      ).

closure([], Closure, Closure, _, _) --> [].
closure([P1*P2|L1], Sofar1, Closure, Arcs1, Arcs2) -->
  {filter_arcs(Arcs1, P1, Arcs3)},
  {filter_arcs(Arcs2, P2, Arcs4)},
  {keyclumped(Arcs3, KL1)},
  {keyclumped(Arcs4, KL2)},
  ( foreach(A-Clump1,KL1),
    fromto(Incr,S0,S6,[]),
    param(KL2,P1,P2)
  do ( foreach(B-Clump2,KL2),
      fromto(S0,S1,S5,S6),
      param(A,Clump1,P1,P2)
    do ( {A==B} ->
        ( foreach(X,Clump1),
          fromto(S1,S2,S4,S5),
          param(A,Clump2,P1,P2)
        do ( foreach(Y,Clump2),
            fromto(S2,[X*Y|S3],S3,S4),
            param(A,P1,P2,X)
            do [arc(P1*P2,A,X*Y)]
          )
        )
        ; {S1 = S5}
      )
    )
  ),
  {sort(Incr, Incr1)},
  {ord_union(Sofar1, Incr1, Sofar2, L2)},
  {append(L1, L2, L3)},
  closure(L3, Sofar2, Closure, Arcs1, Arcs2).

filter_arcs([], _, []).
filter_arcs([arc(P,A,Q)|Arcs], P1, KL) :-
  compare(K, P, P1),
  filter_arcs(K, A, Q, Arcs, P1, KL).

filter_arcs(<, _, _, Arcs, P1, KL) :-
  filter_arcs(Arcs, P1, KL).
filter_arcs(=, A, Q, Arcs, P1, [A-Q|KL]) :-
  filter_arcs(Arcs, P1, KL).
filter_arcs(>, _, _, _, _, []).

%% first, transform to DFA if need be
%% then, minimize
kernel_normalize(Kernel1, Kernel3) :-
  ensure_dfa(Kernel1, Kernel2),
  Kernel2 = kernel(SourcesSinks1,Arcs1),
  Kernel3 = kernel(SourcesSinks3,Arcs3),
  make_penta(SourcesSinks1, Arcs1, Penta1),
  remove_unreachable(Penta1, Penta2),
  Penta2 = penta(States2,_,_,Sinks2),
  ord_subtract(States2, Sinks2, NonSinks2),
  ( Sinks2\=[], NonSinks2\=[] -> Partition0 = [NonSinks2,Sinks2]
  ; true -> Partition0 = [States2]
  ),
  refine_partition(Partition0, Partition, Penta2),
  collapse(Penta2, Partition, Penta3),
  Penta3 = penta(States3,ArcsF3,Sources3,Sinks3),
  avl_to_list(ArcsF3, ArcsL3),
  ( foreach((P-A)-Q,ArcsL3),

```

```

        foreach(arc(P,A,Q),Arcs3)
    do true
    ),
    tag_sources_sinks(Sources3, Sinks3, SS1, SS2),
    append(SS1, SS2, SourcesSinks3),
    numbervars(Kernel3, 0, _).

make_penta(SourcesSinks, Arcs, penta(States,Alfa0,ArcsF,Sources,Sinks)) :-
    (
        foreach(Item,SourcesSinks),
        fromto(Sources0,So1,So2,[]),
        fromto(Sinks0,Si1,Si2,[])
    do (
        Item = source(Y) -> So1 = [Y|So2], Si1 = Si2
        ; Item = sink(Y) -> So1 = So2, Si1 = [Y|Si2]
        )
    ),
    (
        foreach(arc(P,A,Q),Arcs),
        foreach(A,Alfa0),
        foreach((P-A)-Q,ArcsFL),
        fromto(States0,[P,Q|S],S,[])
    do true
    ),
    sort(ArcsFL, ArcsFOL),
    ord_list_to_avl(ArcsFOL, ArcsF),
    sort(States0, States1),
    sort(Alfa0, Alfa0),
    sort(Sources0, Sources),
    sort(Sinks0, Sinks),
    ord_union([States1,Sources,Sinks], States).

remove_unreachable(Penta1, Penta2) :-
    Penta1 = penta(_, Alfa,ArcsF1,Sources1,Sinks1),
    Penta2 = penta(States2,Alfa,ArcsF2,Sources2,Sinks2),
    avl_to_list(ArcsF1,ArcsFL),
    (
        foreach((P-)-Q,ArcsFL),
        fromto(EdgesF1,[P-Q|EdgesF2],EdgesF2,AuxF),
        fromto(EdgesB1,[Q-P|EdgesB2],EdgesB2,AuxB)
    do true
    ),
    (
        foreach(So,Sources1),
        fromto(AuxF,[(*)-So|AuxF1],AuxF1,[])
    do true
    ),
    (
        foreach(Si,Sinks1),
        fromto(AuxB,[(*)-Si|AuxB1],AuxB1,[])
    do true
    ),
    vertices_edges_to_ugraph([*], EdgesF1, GF),
    vertices_edges_to_ugraph([*], EdgesB1, GB),
    reachable(*, GF, ReachF),
    reachable(*, GB, ReachB),
    ord_intersection(ReachF, ReachB, ReachFB),
    ord_del_element(ReachFB, *, States2),
    ord_intersection(Sources1, States2, Sources2),
    ord_intersection(Sinks1, States2, Sinks2),
    (
        foreach((P1-A1)-Q1,ArcsFL),
        fromto(ArcsFL2,ArcsFL3,ArcsFL4,[]),
        param(States2)
    do (
        ord_member(P1,States2),
        ord_member(Q1,States2) ->
        ArcsFL3 = [(P1-A1)-Q1|ArcsFL4]
        ; ArcsFL3 = ArcsFL4
        )
    ),
    ord_list_to_avl(ArcsFL2, ArcsF2).

refine_partition(Part0, Part, Penta) :-
    (
        fromto(1,_,D,0),
        fromto(Part0,Part1,Part2,Part),

```

```

        param(Penta)
    do refine_partition1(Part1, Part2, Penta),
        length(Part1, N1),
        length(Part2, N2),
        D is N1-N2
    ).

refine_partition1(Part1, Part2, Penta) :-
    Penta = penta(_,Alfa,ArcsF,_,_),
    ( foreach(Part,Part1),
      count(I,1,_)
    fromto(AL,AL1,AL3,[])
    do ( foreach(S,Part),
        fromto(AL1,[S-I|AL2],AL2,AL3),
        param(I)
        do true
        )
    ),
    sort(AL, AOL),
    ord_list_to_avl(AOL, Map),
    ( foreach(Q-J,AL),
      foreach((J-SignSet)-Q,KL1),
      param(Alfa,Map,ArcsF)
    do ( foreach(A,Alfa),
        fromto(Sign,Sign1,Sign2,[]),
        param(Q,Map,ArcsF)
        do ( avl_fetch(Q-A, ArcsF, R) ->
            avl_fetch(R, Map, R1),
            Sign1 = [s(A,R1)|Sign2]
            ; Sign1 = Sign2
            )
        ),
        sort(Sign, SignSet)
    ),
    keysort(KL1, KL2),
    keyclumped(KL2, KL3),
    ( foreach(_-Clump,KL3),
      foreach(Clump,Part2)
    do true
    ).

collapse(Penta1, Partition, Penta2) :-
    Penta1 = penta(States1,Alfa,Arcs1,Sources1,Sinks1),
    Penta2 = penta(States2,Alfa,Arcs2,Sources2,Sinks2),
    ( foreach(Part,Partition),
      fromto(AL,AL1,AL3,[])
    do ( foreach(S0,Part),
        fromto(AL1,[S0-SI|AL2],AL2,AL3),
        param(SI)
        do true
        )
    ),
    sort(AL, AOL),
    list_to_avl(AOL, Map),
    ( foreach(Q1,States1),
      foreach(R1,States1b),
      param(Map)
    do avl_fetch(Q1, Map, R1)
    ),
    avl_to_list(Arcs1, Arcs1L),
    ( foreach((P-A)-Q,Arcs1L),
      foreach((R-A)-S,Arcs2L),
      param(Map)
    do avl_fetch(P, Map, R),
      avl_fetch(Q, Map, S)
    ),
    sort(Arcs2L, Arcs20L),
    ord_list_to_avl(Arcs20L, Arcs2),

```

```

(  foreach(Q2,Sources1),
  foreach(R2,Sources1b),
  param(Map)
do  avl_fetch(Q2, Map, R2)
),
(  foreach(Q3,Sinks1),
  foreach(R3,Sinks1b),
  param(Map)
do  avl_fetch(Q3, Map, R3)
),
sort(States1b, States2),
sort(Sources1b, Sources2),
sort(Sinks1b, Sinks2).

/* NFA to DFA: standard powerset construction algorithm. */

ensure_dfa(Kernel1, Kernel2) :-
  kernel_parts(Kernel1, Sources, Sinks, _, Arcs, Alphabet),
  (  foreach(arc(Q1,A,Q2),Arcs),
    foreach(Q1*A - Q2,KL1)
  do  true
  ),
  keyclumped(KL1, KL2),
  (  Sources = [_,_|_] -> true
  ;  member(_[_,_|_], KL2) -> true
  ), !,
  ord_list_to_avl(KL2, Trans),
  det_closure([Sources], Alphabet, Trans, [Sources], DStates, [], DArcs),
  DSources = [Sources],
  det_select(DStates, Sinks, DSinks),
  tag_sources_sinks(DSources, DSinks, ESources, ESinks),
  append(ESources, ESinks, ESS),
  Kernel2 = kernel(ESS,DArcs).
ensure_dfa(Kernel, Kernel).

det_closure([], _, _, States, States, Arcs, Arcs).
det_closure([R1|Queue], Alphabet, Trans, States0, States, Arcs0, Arcs) :-
  det_arcs(R1, Alphabet, Trans, Arcs2),
  sort(Arcs2, Arcs3),
  (  foreach(arc(_,_),R2),Arcs3),
  foreach(R2,R2s)
do  true
),
sort(R2s, R3s),
ord_subtract(R3s, States0, New),
ord_union(R3s, States0, States1),
ord_union(Arcs0, Arcs3, Arcs1),
append(Queue, New, Queue1),
det_closure(Queue1, Alphabet, Trans, States1, States, Arcs1, Arcs).

det_arcs(R1, Alphabet, Trans, Arcs) :-
  (  foreach(A,Alphabet),
    foreach(Arc,Arcs),
    param(R1,Trans)
  do  (  foreach(Q1,R1),
        fromto(Qs1,Qs2,Qs3,[]),
        param(A,Trans)
      do  avl_fetch(Q1*A, Trans, Q1As),
          append(Q1As, Qs3, Qs2)
      ),
      sort(Qs1, Qs4),
      Arc = arc(R1,A,Qs4)
  ).

det_select(All, Key, Selected) :-
  (  foreach(X,All),
    fromto(Selected,Sel1,Sel2,[]),
    param(Key)

```

```

do ( ord_disjoint(X, Key) -> Sel1 = Sel2
; Sel1 = [X|Sel2]
)
).

kernel_string(Kernel, String) :-
Kernel = kernel(SourcesSinks,Arcs),
( foreach(Item,SourcesSinks),
fromto(Init1,Init2,Init3,Init4),
fromto(Sinks1,Si1,Si2,[])
do ( Item = source(Y) -> Init2 = [Y-[]|Init3], Si1 = Si2
; Item = sink(Y) -> Init2 = Init3, Si1 = [Y|Si2]
)
),
sort(Sinks1, Sinks),
( foreach(arc(Q2,A,Q3),Arcs),
foreach(Q2-(A-Q3),KL1)
do true
),
),
keysort(KL1, KL2),
keyclumped(KL2, KL3),
ord_list_to_avl(KL3, Map),
kernel_string(Init1, Init4, Sinks, Map, String).

kernel_string(Head, Tail1, Sinks, Map, String) :-
Head\==Tail1,
Head = [State-Stack|Head1],
( ord_member(State, Sinks),
reverse(Stack, String)
; avl_fetch(State, Map, Clump)
-> ( foreach(A-Q,Clump),
fromto(Tail1,Tail2,Tail3,Tail4),
param(Stack)
do Tail2 = [Q-[A|Stack]|Tail3]
),
kernel_string(Head1, Tail4, Sinks, Map, String)
; kernel_string(Head1, Tail1, Sinks, Map, String)
).

kernel_print_dot(kernel(SourcesSinks,Arcs)) :-
write('digraph automaton {\n'),
write(' size="8.5,11";\n'),
write(' fontsize="24";\n'),
write(' rankdir=LR;\n'),
write(' edge [labelfontsize="10";\n'),
write(' node [shape=circle];\n'),
write(' source [shape=none, label=""]; \n'),
write(' comment [shape=box, label="'];\n'),
write('];\n'),
( foreach(SS,SourcesSinks)
do ( SS = source(X)
-> format(' source -> ~w;\n', [X])
; SS = sink(X)
-> format(' ~w [shape=doublecircle];\n', [X])
)
),
( foreach(Arc,Arcs),
foreach(arc3(A,C)-B,KL1)
do Arc = arc(A,B,C)
),
),
keysort(KL1, KL2),
keyclumped(KL2, KL3),
( foreach(arc3(V,W)-Lets,KL3)
do label_dot(Lets, Ldot),
format(' ~w -> ~w [taillabel="~w";\n', [V,W,Ldot])
),
),
write('}\n\n').

```

```

label_dot(Lets, Dot3) :-
    ( foreach(L,Lets),
      fromto(' ',Dot1,Dot2,Dot3)
    do name(L, Lcodes),
      atom_codes(A, Lcodes),
      atom_concat(Dot1, A, Dot2)
    ).

end_of_file.

%%% Some examples:

| ?- regex_kernel([w,o,r,d], K).
K = kernel([source(A),sink(B)], [arc(C,d,B),arc(D,o,E),arc(E,r,C),arc(A,w,D)]) ?

| ?- regex_kernel({}, K).
K = kernel([source(A),sink(A)], []) ?

| ?- regex_kernel([a],[b,c], K).
K = kernel([source(A),sink(B)], [arc(A,a,B),arc(A,b,C),arc(C,c,B)]) ?

| ?- regex_kernel(*([a,b]), K).
K = kernel([source(A),sink(A)], [arc(B,b,A),arc(A,a,B)]) ?

| ?- regex_kernel([a],[b]+[a],[b]), K).
K = kernel([source(A),sink(B)], [arc(A,a,C),arc(A,b,C),arc(C,a,B),arc(C,b,B)]) ?

| ?- regex_kernel([a],[b]+[a],[b])/[a,b], K).
K = kernel([source(A),sink(B)], [arc(A,a,C),arc(C,b,B)]) ?

| ?- regex_kernel([a],[b]+[a],[b])\[a,b], K).
K = kernel([source(A),sink(B)], [arc(A,a,C),arc(A,b,D),arc(C,a,B),arc(D,a,B),arc(D,b,B)]) ?

| ?- regex_kernel(*([a] + [b] + *([a])), K).
K = kernel([source(A),sink(B)], [arc(A,a,A),arc(A,b,B),arc(B,a,B)]) ?

| ?- regex_kernel(shuffle([a,b],s), K).
K = kernel([source(A),sink(B)], [arc(C,a,D),arc(A,a,E),arc(A,s,C),arc(E,b,F),arc(E,s,D),arc(D,b,B),arc(F,s,B)]) ?

| ?- regex_kernel(shuffle([a,b],s), K), kernel_string(K,S).
K = kernel([source(A),sink(B)], [arc(C,a,D),arc(A,a,E),arc(A,s,C),arc(E,b,F),arc(E,s,D),arc(D,b,B),arc(F,s,B)]),
S = [a,b,s] ? ;
K = kernel([source(A),sink(B)], [arc(C,a,D),arc(A,a,E),arc(A,s,C),arc(E,b,F),arc(E,s,D),arc(D,b,B),arc(F,s,B)]),
S = [a,s,b] ? ;
K = kernel([source(A),sink(B)], [arc(C,a,D),arc(A,a,E),arc(A,s,C),arc(E,b,F),arc(E,s,D),arc(D,b,B),arc(F,s,B)]),
S = [s,a,b] ? ;
no

| ?- regex_kernel(prefix([w,o,r,d]), K), findall(S, kernel_string(K,S), Prefixes).
K = kernel([source(A),sink(B),sink(C),sink(D),sink(E),sink(A)], [arc(C,d,B),arc(D,o,E),arc(E,r,C),arc(A,w,D)]),
Prefixes = [ [], [w], [w,o], [w,o,r], [w,o,r,d] ] ?

| ?- regex_kernel(suffix([w,o,r,d]), K), findall(S, kernel_string(K,S), Suffixes).
K = kernel([source(A),sink(B),sink(A)], [arc(C,d,B),arc(D,o,E),arc(E,r,C),arc(A,d,B),arc(A,o,E),arc(A,r,C),arc(A,w,D)]),
Suffixes = [ [], [d], [r,d], [o,r,d], [w,o,r,d] ] ?

```