

Identification Algorithm to Determine the Trajectory of Robots with Singularities

Hossein Sharifi, William C. Black

Abstract—Singularity in robot controls is an important problem. By identifying an appropriate trajectory for the robots, the singular situations can be avoided. In this paper an identification algorithm is proposed to control the robot such that it can change its direction to avoid the singularity situation. Based on the singular value decomposition, the proposed algorithm is developed for the non-redundant, single-rank robots. The proposed method is employed on a robot with six degrees of freedom, in order to identify its feasible trajectory.

Keywords: Singularity; Trajectory identification; Robot control; Identification algorithm; Singular value decomposition.

I. INTRODUCTION

Singularity occurrence in robot manipulators is considered as one of the challenging issues. In a singular situation, a robot may lose one or more degrees of freedom; meaning that the states in some directions will be zero [1-6]. The singularity may cause infinity speed in some joint. The directions which are affected by the singularity are known as the singular directions. In terms of a singularity in a joint, order reduction will happen in the Jacobian matrix. This order reduction will cause the matrix to be irreversible. Therefore, the control of the robot with irreversible Jacobian matrix will be extremely problematic [7-19].

Several researchers have investigated the robot singularity in different ways. In [7], the robot joint velocities in singular situation have been surveyed; however, the authors only considered the perpendicular directions when a singularity happens, to determine the feasible paths. In another study [8], the authors have studied several control algorithms to control the robot's singularity; the methods are based on the inverse kinematic approach. One of the most important problems in robot singularity is that, the robot tends to move toward the singular direction once a singularity happens. To solve this issue, in this paper, we will analyze the robot trajectory in singular situation, and we will determine a feasible trajectory to avoid singularity through a proposed identification algorithm. In the proposed approach, through the identification algorithm, we will identify the possible paths once the singularity happens. Then, the robot will be directed to the trajectories that help it to avoid the singularity. The developed algorithm in this paper is based on the singular value decomposition method. The feasible paths in this method are the ones that result in finite outputs for the finite inputs (guarantees stability). Authors in [9] have proposed a similar approach based on strong equivalency for an electric network. They have identified the system through their proposed identification algorithm, such that they can guarantee avoiding singularity in the system.

In the rest of the paper, you will read section II which

explains the mathematical formulation of the singular model, and the singular velocity model for the robot. Section III contains the identification of feasible paths in singularity. The proposed method is implemented on a robot with six degrees of freedom in section IV. Eventually, section V is the conclusion section.

II. MATHEMATICAL MODEL DEFINITION

As stated in the previous section, singularity results in irreversible Jacobian matrix, due to the matrix order reduction. The relationship between the velocity of joints and velocity of the end-points is represented as Eq. 1 [10-17]. In the following equation, J is the Jacobian matrix, \dot{q} represents the velocity of joints, and \dot{X} denotes the velocity of the end-points, n represents the number of joints, and m is the number of degrees of freedom.

$$\dot{X} = J \times \dot{q} \quad (1)$$

Based on the singular value decomposition method, the Jacobian matrix can be decomposed into the multiply of three matrices as Eq. 2. Moreover, the $V = [v_1, v_2, \dots, v_n]$ matrix is a perpendicular matrix which is the multiply of matrices J and J^T . We want to mention that, the parameters can be tuned through the adaptive or fuzzy algorithms as in [15] and [17].

$$J = U \times \Sigma V^T \quad (2)$$

Furthermore, U contains the eigen vectors of $J \times J^T$. Matrix Σ can be defined also as Eq. 3.

$$\Sigma = \begin{bmatrix} \hat{\Sigma}_{[r \times r]} & 0_{[r \times (n-r)]} \\ 0_{[(m-r) \times r]} & 0_{[(m-r) \times (n-r)]} \end{bmatrix} \quad (3)$$

In above equation, r denotes the rank of the Jacobian matrix, and the 0s are the zero matrices with the associated dimensions. The diagonal elements of $\hat{\Sigma}$ are calculated from the squared root values of the eigen values of matrix $J \times J^T$ as Eq. 4.

$$\sigma_1 \geq \sigma_2 \geq \dots \geq \sigma_m \quad (4)$$

From the eigen value decomposition method, inverse of the Jacobian matrix is calculated in Eq. 5.

$$J^* = V \times \sum^* \times U^T, \quad (5)$$

$$\sum^* = \begin{bmatrix} \hat{\Sigma}^* & 0_{[r \times (n-r)]} \\ 0_{[(n-r) \times r]} & 0_{[(n-r) \times (m-r)]} \end{bmatrix}$$

The $\hat{\Sigma}^*$ matrix is calculated from Eq. 6.

$$\sum^* = \text{diag}\left(\frac{1}{\sigma_1}, \frac{1}{\sigma_2}, \dots, \frac{1}{\sigma_r}\right) \quad (6)$$

In a singularity case, $\sigma_1, \sigma_2, \dots, \sigma_m = 0$. Therefore, the last columns of U matrix (from u_{r+1} to u_m) are zero. The singular direction here is determined based on the direction of u_m . Thus, we have the following equation.

$$\dot{d} = u_m^T \times \dot{X} \quad (7)$$

In the above equation, \dot{Y} denotes the $m-1$ non-singular vectors, and \dot{d} is the velocity vector in a singular direction. Thus, Eq. 1 can be rephrased as Eq. 8.

$$\begin{aligned} \dot{Y} &= K \times \dot{q} \\ \dot{d} &= L \times \dot{q} \end{aligned} \quad (8)$$

In the above equation, K and L are the sub-matrices of $U^T \times J$. In a singular situation, \dot{d} is zero, and L is also zero. We should mention that the velocity matrix \dot{q} is non-zero.

III. IDENTIFICATION OF FEASIBLE PATHS

By derivation of Eq. 8, and knowing that $L = 0$, $\dot{d} = 0$, the singular acceleration is represented as:

$$\ddot{d} = \frac{dL}{dt} \dot{q} = (\dot{q}^T \times \theta \times L^T) \times \dot{q} \quad (9)$$

$$\theta = \begin{bmatrix} \frac{dl_1}{dq_1} & \frac{dl_2}{dq_1} & \dots & \frac{dl_n}{dq_1} \\ \frac{dl_1}{dq_2} & \frac{dl_2}{dq_2} & \dots & \frac{dl_n}{dq_2} \\ \dots & \dots & \dots & \dots \\ \frac{dl_1}{dq_n} & \frac{dl_2}{dq_n} & \dots & \frac{dl_n}{dq_n} \end{bmatrix} \quad (10)$$

According to \dot{Y} matrix in Eq. 8, the K matrix is a full-rank matrix, with $\text{rank} = m-1$. It can be defined as Eq. 25. K_p in this equation is a reversible square matrix, with $m-1$ number of rows and columns, and K_s is a matrix with dimension $(m-1) \times [(n-m+1)]$.

$$K = [K_p, K_s] \quad (11)$$

The \dot{q} matrix also can be decomposed into \dot{q}_p and \dot{q}_s with $(m-1)$, and $(n-m+1)$ dimensions respectively. Therefore,

we can rewrite Eq. 8 as Eq. 12.

$$\dot{Y} = K_p \times \dot{q}_p + K_s \times \dot{q}_s \quad (12)$$

Also, from the previous equations, we have $\dot{q} = M \times \dot{Y} + N \times \dot{q}_s$. Eventually, the equation for the acceleration in the singular direction is attained as Eq. 13. Matrices A , B , and C are defined as Eq. 14.

$$\ddot{d} = \dot{q}_s^T \times A \times \dot{q}_s + B \times \dot{q}_s + C \quad (13)$$

$$\begin{aligned} A &= N \times \theta \times L \times N \\ B &= \dot{Y} \times M^T (\theta \times L^T + \theta \times L) \times N \\ C &= \dot{Y}^T \times M^T \times \theta \times L \times M \times \dot{Y} \end{aligned} \quad (14)$$

Having the above equations, we can analyze the singular situations with non-zero acceleration. here, we are analyzing the singularity in robots. Since the number of degrees of freedom in robots is equal to the number of end-points, the \dot{q}_s vector will be an scalar, and Eq. 15 is attained.

$$\ddot{d} = A \times \dot{q}_s^2 + B \times \dot{q}_s + C \quad (15)$$

In this paper, we assume that robot is in the beginning of its path and the singularity occurs. Therefore, $\dot{Y}(0) = 0$. Based on Eq. 14, matrices B and C will be zero too. Therefore, we will have the Equation below. If A in Eq. 16 is non-zero, the acceleration sign will be the same as A matrix sign. This means that the end-point will be the same sign as A . If A matrix is positive, the end-point will be in the same direction of the singularity, and if it is negative, it will be in the adverse singularity direction. Therefore, we will pick the paths in which the acceleration sign in a singular situation is equal to matrix A sign. If A is zero, Eq. 16 will be as $\ddot{d} = 0$, which means that the robot can not move with any acceleration value in the singular situation. As you could see, based on the matrix A values, we can analyze the possible paths once a singularity happens.

$$\ddot{d} = A \times \dot{q}_s^2 \quad (16)$$

IV. PROPOSED PATH IDENTIFICATION STRATEGY ON A ROBOT WITH SIX DEGREES OF FREEDOM

In this section, our proposed path identification strategy is applied to a robot with six degrees of freedom. The robot is presented in Fig. 1, which has one vertical degree, and five circular degrees of freedom. The robot parameters are shown in Table I.

The Jacobian matrix for this robot will be as follows.

TABLE I: Robot parameters

Joint	α_i	a_i	d_i	θ_i
First joint	0	a_1	d_1	0
Second joint	0	a_2	0	θ_2
Third joint	90	0	0	θ_3
Fourth joint	-90	0	d_4	θ_4
Fifth joint	90	0	0	θ_5
Sixth joint	0	0	0	θ_6

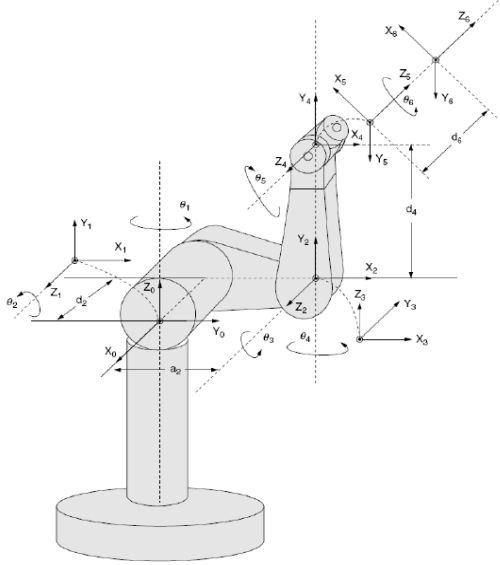

Fig. 1: Robot picture with six degrees of freedom

$$J = \begin{bmatrix} J_{11} & J_{12} \\ J_{21} & J_{22} \end{bmatrix} \quad (17)$$

$$J_{11} = \begin{bmatrix} 0 & d_4 + a_2 \times S_3 & d_4 \\ 1 & 0 & 0 \\ 0 & -a_2 \times C_3 & 0 \end{bmatrix} \quad (18)$$

$$J_{12} = \begin{bmatrix} 0 & 0 & 0 \\ 0 & 0 & 0 \\ 0 & 0 & 0 \end{bmatrix} \quad (19)$$

$$J_{21} = \begin{bmatrix} 0 & 0 & 0 \\ 0 & 1 & 1 \\ 0 & 0 & 0 \end{bmatrix} \quad (20)$$

$$J_{22} = \begin{bmatrix} 0 & -S_4 & C_4 \times S_5 \\ 0 & C_4 & S_4 \times S_5 \\ 1 & 0 & C_5 \end{bmatrix} \quad (21)$$

Since, matrix J_{12} is a zero matrix, the first three degrees of freedom are independent of the next two other degrees of freedom, and the solutions are independent of each other. The first three degrees of freedom eigen values would be as Eq. 22.

$$\begin{aligned} \sigma_1 &= 0.5 \times (a_2^2 + 2d_4^2 + 2a_2d_4S_3) + (a_2^2 + 2d_4^2 + 2a_2d_4S_3)^2 \\ &\quad - 4(a_2d_4C_3)^2 \\ \sigma_2 &= 1 \end{aligned} \quad (22)$$

The singular values of the σ_1 and σ_2 are always positive and non-zero, therefore, the singular situation for the first three degrees of freedom happens only when σ_3 is zero; $\sigma_3 = k\pi + \frac{\pi}{2}$. The Jacobian matrix J_{11} in a singular situation will be as the following equation. The ε value is 1 if k is even, and -1, if k is odd value.

$$J_{11} = \begin{bmatrix} 0 & d_4 + a_4 \times \varepsilon & d_4 \\ 1 & 0 & 0 \\ 0 & 0 & 0 \end{bmatrix} \quad (23)$$

The multiplication of θ with L matrix would be as Eq. 24.

$$\theta \times L = \begin{bmatrix} 0 & 0 & 0 \\ 0 & 0 & a_2 \times S_3 \\ 0 & 0 & 0 \end{bmatrix} \quad (24)$$

And, the K matrix would be as Eq. 25, and \dot{Y} is as 26.

$$K = \begin{bmatrix} 0 & d_4 + a_2 \times \varepsilon & d_4 \\ 1 & 0 & 0 \end{bmatrix} \quad (25)$$

$$\dot{Y} = \begin{bmatrix} 0 & d_4 \\ 1 & 0 \end{bmatrix} \times \begin{bmatrix} \dot{q}_1 \\ \dot{q}_3 \end{bmatrix} + \begin{bmatrix} d_4 + a_2 \times \varepsilon \\ 0 \end{bmatrix} \quad (26)$$

And, K_p and K_s matrices would be as follows:

$$K_p = \begin{bmatrix} 0 & d_4 \\ 1 & 0 \end{bmatrix} \quad (27)$$

$$K_s = \begin{bmatrix} d_4 + a_2 \times \varepsilon \\ 0 \end{bmatrix} \quad (28)$$

Thus, the matrices A , B , and C will be as follows:

$$\begin{aligned} A &= (a_2 \times \varepsilon)^2 \times \left(-\frac{d_4 + a_2 \times \varepsilon}{a_2 \times d_4 \times \varepsilon} \right) \\ B &= C = 0 \end{aligned} \quad (29)$$

Considering that A is always non-zero, and the acceleration in a singular direction follows the sign of A matrix, the possible paths are the ones that the acceleration sign is the same as h parameter sign in Eq. 30.

$$h = -\frac{d_4 + a_2 \varepsilon}{a_2 d_4 \varepsilon} \quad (30)$$

We conclude that if the h sign is positive, the robot can avoid singularity in the direction of the singular eigen vector. If h is negative, the robot will escape the singularity in the direction of the singular eigen vector. The mentioned directions are considered as the limits for the robot.

Also, from Eq. 29, if parameters d_4 and a_2 are equal and ϵ is equal to -1, the A matrix is zero. In this situation, there is no feasible path for the robot to avoid singularity. The same calculations are applied to the other/rest of degrees of freedom.

V. CONCLUSION

In this paper, feasible paths are detected to help the robot avoid singularities. The limit of this identification procedure are analyzed, and the proposed strategy is employed on a robot with six degrees of freedom. In this study, we assumed that the singularity happens when the robot is in the beginning of its path. The identification algorithm developed is based on the singular value decomposition method. The proposed strategy was very efficient and helpful in guiding the robot to avoid the singularity situation.

REFERENCES

- [1] Khalil, W., and Dombre, E. Modeling, Identification & Control of Robots. London ; Sterling, VA: Kogan Page Science, 2004. Kogan Page Science Paper Edition.
- [2] Cheah, Chien Chern., and Li, Xiang. Author. Task-Space Sensory Feedback Control of Robot Manipulators. 1st Ed. 2015.. ed. 2015. Intelligent Systems, Control and Automation: Science and Engineering.
- [3] Lenarcic, J., and Khatib, Oussama, Editor. Advances in Robot Kinematics. 2014.
- [4] Shi, Yan, Hong Xin Yue, Yi Lu, and Lian He Guo. "Singularity Analysis of a Plane-Symmetry 3-RPS Parallel Robot Based on Translational/Rotational Jacobian Matrices." Applied Mechanics and Materials 121-126 (2011): 1590-594.
- [5] Gogu, Grigore. Structural Synthesis of Parallel Robots. Dordrecht ; [London]: Springer, 2008. Solid Mechanics and Its Applications; v. 149, 159, 173, 183.
- [6] Ghosh, B. K., Xi, Ning, and Tarn, Tzyh-Jong. Control in Robotics and Automation Sensor-based Integration. San Diego: Academic, 1999. Academic Press Ser. in Engineering.
- [7] Nakamura, Yoshihiko, and Hideo Hanafusa. "Inverse kinematic solutions with singularity robustness for robot manipulator control." Journal of dynamic systems, measurement, and control 108, no. 3 (1986): 163-171.
- [8] Karger, A. "Classification of serial robot-manipulators with nonremovable singularities." Journal of Mechanical Design 118, no. 2 (1996): 202-208.
- [9] Eini R., and Ranjbar Noei A. 2013. Identification of Singular Systems under Strong Equivalency. International Journal of Control Science and Engineering, 3(3): 73-80. DOI: 10.5923/j.control.20130303.01.
- [10] Hossein Sharifi, "Singular Identification of a Constrained Rigid Robot", International Research Journal of Engineering and Technology (IRJET), Vol. 5, Issue 08, pp. 941-946, 2018.
- [11] Heng, Li Jun, and Abesh Rahman. "Designing a robust controller for a missile autopilot based on Loop shaping approach." arXiv preprint arXiv:1905.00958 (2019).
- [12] Patel, Dev, Li Jun Heng, Abesh Rahman, and Deepika Bharti Singh. "Servo Actuating System Control Using Optimal Fuzzy Approach Based on Particle Swarm Optimization." arXiv preprint arXiv:1809.04125 (2018).
- [13] Ghosh, B. K., Xi, Ning, and Tarn, Tzyh-Jong. Control in Robotics and Automation Sensor-based Integration. San Diego: Academic, 1999. Academic Press Ser. in Engineering.
- [14] Thomas, F., and Perez Gracia, Alba, Editor. Computational Kinematics : Proceedings of the 6th International Workshop on Computational Kinematics (CK2013). 2014. Mechanisms and Machine Science ; 15.
- [15] Eini R., and Abdelwahed S. 2018. Indirect Adaptive fuzzy Controller Design for a Rotational Inverted Pendulum, 2018 Annual American Control Conference (ACC), Milwaukee, WI, USA, pp. 1677-1682. doi: 10.23919/ACC.2018.8431796
- [16] Barbara T. Hyman, Zahra Alisha, Scott Gordon, Secure Controls for Smart Cities; Applications in Intelligent Transportation Systems and Smart Buildings, International Journal of Science and Engineering Applications, Vol. 8, Issue 06, pp. 167-171, 2019.
- [17] Eini R. 2014. Flexible Beam Robust H-infinity Loop Shaping Controller Design Using Particle Swarm Optimization. Journal of Advances in Computer Research, 5(3), Quarterly pISSN: 2345-606x eISSN: 2345-6078.
- [18] Merlet, J.-P. Parallel Robots. Dordrecht ; Boston, Mass.: Kluwer Academic, 2000. Print. Solid Mechanics and Its Applications; v. 74.
- [19] Lenarcic, Jadran., and Husty, Manfred. Editor. Latest Advances in Robot Kinematics. 1st Ed. 2012.. ed. 2012.