

Simultaneous Progressing Switching Protocols for Timing Predictable Real-Time Network-on-Chips

Niklas Ueter¹, Georg von der Brüggen¹, Jian-Jia Chen¹, Tulika Mitra², and Vanchinathan Venkataramani²

¹TU Dortmund University, Germany

²National University of Singapore, Singapore

Abstract—Many-core systems require inter-core communication, and network-on-chips (NoCs) have been demonstrated to provide good scalability. However, not only the distributed structure but also the link switching on the NoCs have imposed a great challenge in the design and analysis for real-time systems. With scalability and flexibility in mind, the existing link switching protocols usually consider each single link to be scheduled independently, e.g., the worm-hole switching protocol. The flexibility of such link-based arbitrations allows each packet to be distributed over multiple routers but also increases the number of possible link states (the number of flits in a buffer) that have to be considered in the worst-case timing analysis.

For achieving timing predictability, we propose less flexible switching protocols, called *Simultaneous Progressing Switching Protocols* (SP²), in which the links used by a flow either all simultaneously transmit one flit (if it exists) of this flow or none of them transmits any flit of this flow. Such an *all-or-nothing* property of the SP² relates the scheduling behavior on the network to the uniprocessor self-suspension scheduling problem. We provide rigorous proofs which confirm the equivalence of these two problems. Moreover, our approaches are not limited to any specific underlying routing protocols, which are usually constructed for deadlock avoidance instead of timing predictability. We demonstrate the analytical dominance of the fixed-priority SP² over some of the existing sufficient schedulability analysis for fixed-priority wormhole switched network-on-chips.

Keywords: Network-on-Chip, Real-Time Scheduling, Simultaneous Progressing Switching Protocols

I. INTRODUCTION

Power dissipation has constrained the performance scaling of single-core systems in the past decade. Instead of increasing the operational frequency of a processor, the chip manufacturers have shifted their design focus towards chips with multiple or many cores that operate at lower voltages and frequencies than their single-core counterparts. In a multi- or many-core system, communication and synchronization of the applications executed on different cores have to be designed efficiently from both hardware and software perspectives.

The communication fabric of a multi- or many-core platform must scale with the number of cores. Otherwise, the computation capacity of the cores may be wasted if they are waiting for the communication, synchronization, or memory access. One possible approach to achieve good scalability of the communication is the Network-on-Chip (NoC) architecture, in which a switched network with routers is used to provide the interconnection of the physical cores on a chip. The NoC architecture allows parallel inter-core communication with moderate hardware costs. NoCs are the prevalent choice of

interconnection due to their overall good performance and scalability potential as reported by Kavaldjiev et. al [22].

The efficiency of a NoC highly depends on many design factors, including topology, routing protocols, flow control, switching arbitration protocols, etc. The currently available multi-core platforms based on NoCs have employed different topologies, e.g., a ring in the *Intel Xeon Phi 3120A*, a 2-D torus in *MPPA Manycores* by Kalray, and a 2-D mesh in *Tilera TILE-Gx8036*. Moreover, many different communication protocols and communication topologies have been proposed and evaluated in the literature. Specifically, *flit-based* network-on-chips (NoCs) have been proposed with the goal to decrease production cost and increase energy efficiency due to less complex routers and decreased buffer sizes as compared to other approaches.

Real-Time system design is concerned with the construction of systems that can be formally verified to satisfy timeliness constraints. Such real-time constraints are prevalent in, e.g., timing-sensitive applications in embedded mobile platforms, automotive, and aerospace applications. To construct a hard real-time system on a NoC, each hard real-time message (defined as an instance of a sporadic/periodic flow) in the NoC has to be successfully transmitted from its source to its destination before its deadline.

The approaches for real-time systems on a NoC apply two general strategies. One is to utilize time-division-multiplexing (TDM) to ensure that the timing constraints are satisfied by constructing the transmission schedule statically with a repetitive table, e.g., in [11], [12], [18], [28], [31], [36], [37], [39]. Another is to apply a priority-based dynamic scheduling strategy in the routers (and switches) to arbitrate the flits in the network, e.g., in [13], [15], [16], [19], [20], [23], [27], [29], [38], [42], [43]. The difficulty of the TDM strategy is to construct the TDM schedule and the global clock synchronization, whilst the difficulty of the priority-based scheduling strategy is to validate the schedulability, i.e., whether all messages can meet their deadlines in the worst case.

Specifically, for dynamic scheduling strategies, the wormhole-switched fixed-priority NoC with preemptive virtual channels has recently been studied in a series of papers. The first attempts to tackle the schedulability analysis were in 1994 in [29] and 1997 in [13]. Both of them were found to be flawed in 1998 by Kim et al. [23], whose analysis was later found to be erroneous in 2005 by Lu et al. [27]. The series of erroneous analyses continued in [13], [23], [27],

[29] until a seemingly correct result by Shi and Burns [38] published in 2008. Eight years later, Xiong et al. [42] pointed out the analytical flaw in [38] and disproved the safe bounds in [19], [20]. The erroneous patch in [42] was later fixed by the authors in their journal revision in [43] in 2017. In the mean time, Indrusiak et al. [15], [16] presented new analyses but admitted to not be able to provide a formal proof of correctness. They supported their analyses by evaluating concrete cases, i.e., whether there was any observed case which was claimed to meet the deadlines but in fact missed the deadlines. However, such case studies cannot validate the correctness of their analyses, as also stated by Indrusiak et al. [15], [16]. Specifically, among the 10 results [13], [15], [19], [20], [23], [27], [29], [38], [42], [43] published up to 2017, Table VII in [15] shows that eight of them were already disproved by counter examples, and two of them are *probably* safe as no counter examples have been given. Niković et al. [30] published the most recent result for the worst-case response timing analysis.

The fact that almost all proposed analyses for the problem discussed in the previous paragraph have been found flawed suggests that the scheduling algorithm and architecture can be potentially too complex to be correctly analyzed. These approaches have adopted the well-known worst-case response time analysis for uniprocessor sporadic real-time tasks under fixed-priority uniprocessor scheduling developed in [17], [25], but they have never shown the connection between worm-hole switching and uniprocessor scheduling.

Another research line to analyze the worst-case response time of wormhole-switched fixed-priority NoC with preemptive virtual channels is to apply Network Calculus and Compositional Performance Analysis (CPA), or their extensions, to analyze the transmission on the links in a compositional manner, e.g., [1], [3], [5], [32], [33], [40]. The worst-case response time of a flow is the sum of the worst-case response times on individual links, which can be pessimistic. One exception is the analysis from Giroudot and Mifdaoui [9], which applies the Pay Multiplexing Only Once principle by Schmitt et al. [35].

Contributions: In this paper, we revisit the fundamental algorithmic problem of flit-based NoC arbitration protocols with respect to real-time constraints by hinting to the fundamental algorithmic complexity. In addition, we identify the analytic pessimism of wormhole-switched fixed-priority arbitration protocols due to the large degree of uncertainty in system behaviour and thus hard to verify timeliness properties.

This paper intends to answer a few unsolved fundamental questions for real-time networking switching in a NoC and has the following contributions:

- *What is the fundamental difficulty of worst-case timing analysis when flit-based transmissions are handled by switch-based (link-based) scheduling?* We will show that the difficulty is mainly due to the explosion of the possible *progression states* of a message in the transmission path. The existing analyses did not intend to prove the coverage of all possible progression states. Moreover, we

will also argue why priority-based scheduling without controlling the number of possible progression states is therefore difficult to be analyzed and optimized.

- *Is there any equivalence between existing uniprocessor scheduling and NoC switching?* Yes, but, to the best of our knowledge, such a protocol has never been designed. For achieving timing predictability, we propose less flexible switching protocols, called *Simultaneous Progressing Switching Protocols* (SP²), in which the links used by a message *either* all simultaneously transmit one flit of this message *or* none of them transmits any flit of this message. Such an *all-or-nothing* property of the SP² relates the scheduling behavior on the network to the uniprocessor self-suspension scheduling problem. We provide rigorous proofs which confirm the equivalence of these two problems.
- We demonstrate the analytical dominance of the (work-conserving) fixed-priority version of our approach over the existing sufficient schedulability analyses for fixed-priority wormhole switched NoCs in [16], [43]. Moreover, our approaches are not limited to any specific underlying routing protocols, which are usually constructed for deadlock avoidance instead of timing predictability.

II. SYSTEM MODEL AND PROBLEM DEFINITION

Network-on-Chips (NoCs) are characterized by the topology, routing protocol, arbitration, buffering, flow control mechanism, and switching protocol.¹ In this paper, we define a NoC as a collection of cores \mathbf{A} , routers \mathbf{V} , and links $\mathbf{\Lambda}$. Each router is connected to at least one other router by two physically separate links, i.e., up-link and down-link. Figure 1 illustrates a meshed network with 9 cores, $\mathbf{A} = \{A_i \mid i = 1, 2, \dots, 9\}$, 9 routers $\mathbf{V} = \{V_i \mid i = 1, 2, \dots, 9\}$, and 24 links in $\mathbf{\Lambda}$ between V_i and V_j for some i and j and 18 links between A_i and V_i for $i = 1, 2, \dots, 9$. We assume that all the cores, routers, and links are homogeneous. Therefore, the transmission rate and processing capability are identical.

A. Switching Mechanisms

With respect to switching, three different switching protocols have been established, namely, circuit switching, store-and-forward switching, and wormhole switching.

1) *Circuit Switching:* A packet (transmission unit) is forwarded by the routers through dedicated routes that are reserved/allocated until the transmission is finished. Therefore, each transmission can only be preempted during the establishing of a route. An advantage of this approach is that no buffers are required and subsequent arbitrary deadlock-free routing, which allows for optimized and adaptive routing schemes. However, the overhead to establish the routes may render this approach infeasible when small packets are injected frequently.

¹Our notation of *flows* is equivalent to *tasks* and our notation of *messages* is equivalent to *jobs* in the classical notation of real-time systems community.

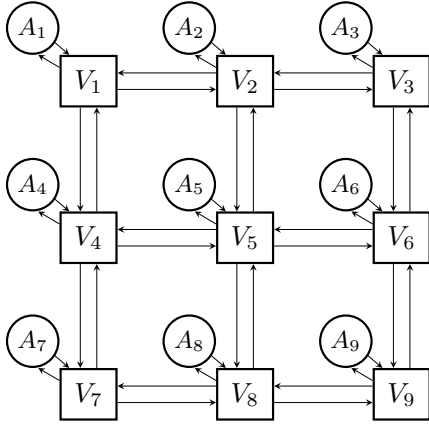

Fig. 1: Exemplary 3x3 mesh NoC. Each application is connected to a source-router where it injects messages.

2) *Store-And-Forward Switching*: Routers can only forward a packet once it is completely received and stored, which implies that the routers must provide sufficient buffer capacity to store a complete packet. Fortunately, the arbitration protocol is suitable for real-time analysis, since a packet may compete for at most one link at each point in time.

3) *Wormhole-Switching*: Each packet is divided into smaller transmission units, called flits, always including a designated header and a designated tail flit which are used for control and routing. That is, each payload flit follows the output port of the header flit. In fixed-priority wormhole-switched NoCs, each router contains virtual channels, i.e., separated buffers that contain flits of a single packet. Once the tail flit is transmitted and removed from the buffer, the virtual channel can be used for flits of another packet. Furthermore, the highest-priority flit is scheduled to transmit over the link at each router. In this approach, complete packets do not have to be buffered and which allows smaller buffers in the hardware design. On the downside, each packet may be distributed over multiple routers and subsequently compete for multiple links at the same time which makes the timing analysis complex. Additionally, the limited number of virtual channels and full buffers on the receiving router add additional interference which complicate the analysis.

B. Messages and Periodic/Sporadic Flows

A periodic (sporadic) flow f_i generates an infinite sequences of flow instances, called messages, and has the following parameters:

- T_i is the minimum inter-arrival time or period of the flow f_i , i.e., for a periodic flow one message is released exactly every T_i time units and for a sporadic flow two subsequent messages are separated by at least T_i .
- Λ_i is the static routing path of the flow f_i , i.e., $\lambda_{i1}, \lambda_{i2}, \dots, \lambda_{i\eta_i}$ is the sequence of the η_i links that a message of f_i has to be transmitted on. We assume that

a physical link cannot be used more than once in the static routing path Λ_i for any i .

- C_i is the worst-case number of flits of a message of f_i .
- D_i is the relative deadline of the flow f_i . That is, when a message is injected at time t , its absolute deadline is $t + D_i$. Our protocols are not restricted to any specific relation of the minimum inter-arrival time and the relative deadline D_i . However, our timing analysis will focus on the constrained-deadline cases, where $D_i \leq T_i \forall i$.

C. Problem Definition

The *scheduler design* problem studied in this paper is defined as follows: *We are given a NoC, defined as a collection of cores \mathbf{A} , routers \mathbf{V} , and links Λ . For a given set \mathbf{F} of sporadic or periodic flows on the NoC, the objective is to design a switching mechanism (scheduling algorithm) that can ensure that all messages (instances of the flows) can meet their deadline.*

The *schedulability test* problem studied in this paper is defined as follows: *We are given a NoC, defined as a collection of cores \mathbf{A} , routers \mathbf{V} , and links Λ . For a given set \mathbf{F} of sporadic or periodic flows on the NoC and a switching mechanism, the objective is to validate whether the messages (instances of the flows) can meet their deadlines.*

We assume that the cores and routers are synchronized perfectly with respect to time. That is, there is no clock drift in the NoC. Otherwise, the clock drift must be considered carefully. One solution is to introduce additional delays and interferences to pessimistically bound the impact due to clock drifts. Moreover, we assume *discrete time*, i.e., the NoC operates in the granularity of a fixed time unit and the finest granularity is the flit.

III. EXISTING ANALYTICAL APPROACHES FOR WORM-HOLE SWITCHING

In this section, we will first summarize the existing analytical approaches for the worm-hole switching mechanism in Section III-A. Then, we will explain the mismatch of the existing analyses and the underlying uniprocessor scheduling in Section III-B.

A. Summary of Existing Analyses

A first analytical approach to determine the worst-case response time of sporadic traffic flows in wormhole-switched fixed-priority network-on-chips was given by Mutka [29] and Hary and Ozguner [13]. Both of them are based on the schedulability analysis for uniprocessor sporadic real-time tasks under fixed-priority scheduling developed in [17], [25]. To analyze the worst-case response time of the flow f_i , they considered the complete path Λ_i as a single shared resource, i.e., a uniprocessor. This shared resource may not always be available for f_i , and they modeled the unavailability by *only* considering the higher-priority flows that use any link in Λ_i , called *direct interference*. They concluded that the problem is equivalent to the fixed-priority uniprocessor scheduling, which was disproved by Kim et al. [23], who showed that the flow

f_i can suffer from the interference due to flow f_j even if Λ_i and Λ_j have no intersection, called *indirect interference*. By extending the notion of interference sets developed by Kim et al. [23], Lu et al. [27] proposed to discriminate between flows that could not interfere with each other to reduce the pessimism of the analysis.

However, both of the approaches in [23], [27] assume that the synchronous release of the first messages of the sporadic real-time flows is the worst-case, i.e., similar to the critical instant theorem in classical uniprocessor fixed-priority scheduling proposed by Liu and Layland [26]. This statement was later disproved in 2008 by Shi and Burns [38], where jitter terms were added to model the asynchronous release of the first messages of the sporadic real-time flows. Based on the results of this work, Kashif and Patel proposed a link-based analysis called stage-level analysis [19], [20] to achieve a tighter analysis. Both analyses were proved to be unsafe by Xiong et al. [42] using simulations. It was discovered that a flit of a higher-priority flow may induce interference more than once, i.e., on multiple routers, thus rendering the conjectures made by Shi and Burns [38] and Kashif and Patel [19], [20] false. This behavior is referred to as multi-point progressive blocking by Indrusiak et al. [16]. The state of the art with respect to fixed-priority wormhole-switched networks-on-chips with infinite buffers is represented by [15], [43]. Unfortunately, the infinite buffer assumption is infeasible in real systems, thus back-pressure effects that occur due to limited buffer sizes in the routers have to be considered. In the work of Indrusiak et al. [16], the authors incorporate buffer sizes into the worst-case response time analysis. Unfortunately, the authors admit to not be able to provide a formal proof of correctness of their models and analyses, thus further counterexamples may be found. The fact that almost all proposed analyses have been found to be flawed, suggests that the scheduling algorithm and architecture are too complex to be reasonably analyzed. Further evidence for this claim is that in the analyses provided by Indrusiak et al. [16], increased buffer sizes lead to increased worst-case response times. Nikol'ic et al. [30] presented an improved analysis over the results in [16], [43].

Motivated by this, we revisit the fundamental algorithmic problem of packet-based network-on-chip scheduling and identify the analytic pessimism incurred by the complexity of link-based arbitration as harmful to routing and to verification. All the above results in [13], [15], [16], [19], [20], [23], [27], [29], [30], [38], [42], [43] made an assumption that the schedulability analysis is somehow related to a corresponding uniprocessor fixed-priority scheduling problem. However, this has never been formally proved. We will explain the mismatch by using the progression model in Section III-B.

B. Progression Model

In this subsection, we detail why the link-based arbitration problem does not match the uniprocessor scheduling model and illustrate the subsequent problems in response-time analyses using uniprocessor scheduling theory. To explain the mismatch, we will focus on the possible buffer states of one

instance (i.e., message) of a flow f_i under analysis. Let \vec{B}_i denote the state vector of the number of flits that are buffered in the cores and routers involved in the path Λ_i . Suppose that there are η_i links involved in Λ_i . Note that the first element in \vec{B}_i denotes the number of flits of the whole message of f_i in the source core to be sent and the last element in \vec{B}_i denotes the number of flits that have been received at the destination core.

Recall our assumption in Section II-C that the NoC is assumed to be fully synchronized in time. Therefore, in each time unit, a buffered flit can be forwarded to the next node (a core or a router). Since the NoC works in discrete time, we can observe the changing of the vector \vec{B}_i over time when considering only the time units at which the message is sent.

When a flit is sent in a time unit at the j -th link in Λ_i , then the buffer of the j -th node is reduced by 1 and the buffer of the $j+1$ -th node in Λ_i is increased by 1. For notational brevity, let \vec{y}_j be a vector of $\eta_i + 1$ elements in which all the elements are 0 except the j -th element that is -1 and the $j+1$ -th element that is 1. For example, $\vec{y}_1 + \vec{y}_2$ implies that the first and the second links send one flit forward in this time unit. Moreover, $\vec{y}_1 + \vec{y}_3$ implies that the first and the third links send one flit forward in this time unit.

Definition 1 (Progression). *Consider a buffer state \vec{B}_i at time t , in which all elements in \vec{B}_i are non-negative integers. Suppose element z_j is either 0 or 1 for $j = 1, 2, \dots, \eta_i$ and at least one of them is 1. Specifically, when z_j is 1, the j -th link sends one flit forward.*

Let \vec{Y} be $\sum_{j=1}^{\eta_i} z_j \vec{y}_j$. For a buffer state \vec{B}_i , z_j for $j = 1, 2, \dots, \eta_j$, and a vector \vec{Y} defined above, the change of the buffer state is valid if

- all elements in $\vec{B}_i + \vec{Y}$ are non-negative integers, and
- the j -th element in \vec{B}_i is $\geq z_{j+1}$ for $j = 1, 2, \dots, \eta_i - 1$.

*If the change of the buffer state is valid, we say that the flow makes a **progression** in this time unit, i.e., one clock cycle. \square*

In a time unit, a link may or may not be utilized to send one flit of f_i in the switching mechanism. Therefore, there are 2^{η_i} combinations of the vectors of \vec{y}_j s. Note that progressions do not have to take place in two consecutive time units. If the message is not sent in the next time unit at all, there is no progression of the message. As an illustrative example, consider $C_i = 10$ and that the message is sent from core A_1 via R_1 and R_2 to core A_2 in the NoC illustrated in Figure 1. If one flit is sent in a time unit, we get $\vec{B}_i = (C_i - 1, 1, 0, 0)$. Now, there are three possibilities for the next time unit when the NoC transmits a flit or multiple flits of the message:

- $\vec{B}_i = (C_i - 1, 0, 1, 0)$: That is, A_1 does not send any flit but R_1 sends a flit to R_2 . The progression is due to $\vec{Y} = (0, -1, 1, 0)$.
- $\vec{B}_i = (C_i - 2, 2, 0, 0)$: That is, A_1 sends one flit to R_1 but R_1 does not send a flit to R_2 , i.e., $\vec{Y} = (-1, 1, 0, 0)$.
- $\vec{B}_i = (C_i - 2, 1, 1, 0)$: That is, A_1 sends one flit to R_1 and R_1 sends a flit to R_2 , which means that the progression is due to $\vec{Y} = (-1, 1, 0, 0) + (0, -1, 1, 0) = (-1, 0, 1, 0)$.

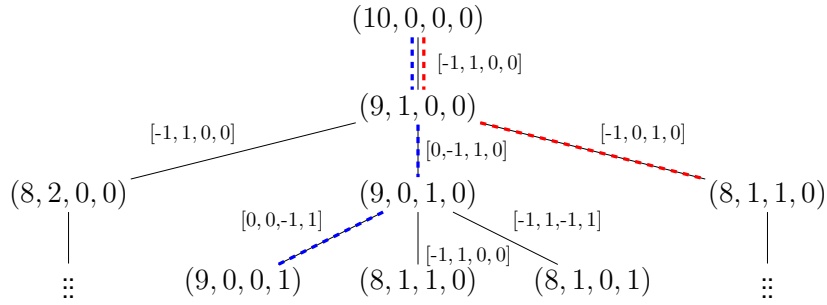

Fig. 2: Progressions of a message which involves 2 cores and 2 routers, i.e., 3 links, when $C_i = 10$. The numbers associated to an edge indicate the change of the buffers in the vector \vec{B}_i . The red dashed path illustrates the beginning of a *fastest* progression and the blue dashed path illustrates the beginning of a *slowest* progression.

The first three levels of the tree illustrated in Figure 2 provides the above example. In each of the above state, the next progression has to be considered. Due to space limitation, we only further illustrate the progressions that are possible when \vec{B}_i is $(9, 0, 1, 0)$.

Definition 2 (A Series of Progressions). *A series of progressions is a sequence of progressions defined in Definition 1, one after another, starting from $\vec{B}_i = (C_i, 0, 0, \dots, 0)$ to $\vec{B}_i = (0, 0, \dots, C_i)$.* \square

A safe analysis of the worst-case response time or the schedulability for sending the message should consider all possible series of progressions of f_i starting from $\vec{B}_i = (C_i, 0, 0, \dots, 0)$ to $\vec{B}_i = (0, 0, \dots, C_i)$. If we only account for the number of time units when the message of f_i is transmitted, it is not difficult to see that the *slowest* one only sends one flit forward per progression, in which the switching mechanism results in $C_i \times \eta_i$ iterations of progressions. Moreover, the *fastest* one sends one flit (if available) forward for all cores and routers involved in the path λ_i per progression, in which the switching mechanism results in $C_i + \eta_i - 1$ iterations of progressions.

All the results in [13], [15], [16], [19], [20], [23], [27], [29], [30], [38], [42], [43] made an assumption that the corresponding uniprocessor scheduling problem can use $C_i + \eta_i - 1$ as the worst-case execution time of the corresponding sporadic task to represent the flow f_i . This assumption implicitly implies that the flow f_i takes the fastest series of progressions explained above. Such uniprocessor analyses are only valid when the other iterations of progressions are accounted correctly. However, the fastest series of progressions for f_i is not always possible in the worst case. To ensure the correctness of the analysis, some additional time units should be included. Many patches have been provided to account for such additional time units after the series of flaws found in [13], [19], [20], [23], [27], [29], [38], [42].

Informally speaking, the researchers in [13], [15], [16], [19], [20], [23], [27], [29], [30], [38], [42], [43] have tried to construct their analyses by linking the problem to a corresponding uniprocessor scheduling problem. Most of them were later found flawed, e.g., [13], [19], [20], [23], [27],

[29], [38], [42], or without a formal proof, e.g., [15], [16], [30].² However, none of them has seriously considered all the possible progressions for transmitting f_i . Whether the worst-case response time analysis for preemptive worm-hole switching is equivalent to any specific form of uniprocessor scheduling problem remains as an open question.

We strongly believe that the worst-case response time analysis or the schedulability analysis for wormhole-switched fixed-priority network-on-chip is highly complex, as the *timing behavior is not uniprocessor equivalent*, as reported in the literature. In a uniprocessor system, if a job is executed for δ time units, the execution time of the job is reduced by δ time units. However, sending δ flits can have different series of progressions in the NoC.

If we would like to consider the complete path Λ_i as a single shared resource, like in [13], [15], [16], [19], [20], [23], [27], [29], [30], [38], [42], [43], and analyze the worst-case behavior by utilizing the corresponding instance of the uniprocessor scheduling problem, the mapping from the series of the progressions to the uniprocessor problem must be *formally proved*.

Please note that we do not claim that such a mapping is impossible. We only stated the mismatch. Such mappings are potentially very difficult to achieve precisely due to the large search space. However, safe approximations and upper bounds are also missing in the literature. In both cases, a correct proof should explain how to safely account for the number of iterations in the progressions of the flows and map them to the corresponding execution time in the constructed instance of the uniprocessor scheduling problem.

IV. SIMULTANEOUS PROGRESSING SWITCHING PROTOCOLS

To the best of our knowledge, there is no formal proof to demonstrate the connection between the progressions of the messages on a NoC and the corresponding instance of the uniprocessor scheduling problem. We note that the analytical

²The proofs in [30] did not consider the equivalence of the worst-case response time analysis adopted in uniprocessor systems and the analysis of a NoC. Instead, they emphasized the quantification of different types of interferences. However, in many places in the proofs, e.g., the building blocks from Lemmas 3, 4, and 6 in [30], the derivation is based on examples.

difficulty is potentially due to the flexibility introduced in the switching mechanism. In the position papers by Wilhelm et al. [41] and Axer et. al [2], the authors state that system properties that are subject to predictability constraints should already be considered and guaranteed from the design. Since the worm-hole switching protocol was not designed with predictability constraints in mind, designing new protocols that can be safely analyzed without losing too much flexibility or efficiency can be an alternative.

Instead of proving the complex scenarios in the standard worm-hole switching, we propose another protocol which has only *one series of progressions*. This less flexible switching protocols, called *Simultaneous Progressing Switching Protocols* (SP²), achieves timing predictability by enforcing that a flow f_i is eligible to transmit on its route **if and only if** it can be allocated for all links in Λ_i in-parallel. In other words, the links used by a flow f_i *either* all simultaneously transmit one flit of this flow (if it exists) *or* none of them transmits any flit of this flow. As a result, for a progression of f_i in a time unit, some links in Λ_i may be reserved even though there is no flit to be transmitted over this link in this time unit, a behaviour similar to *processor spinning*.

In order to formally define the schedules and analyze the schedulability, we use the following definition.

Definition 3 (Schedules). *A schedule $S_{\lambda_j}(t)$ is a function that maps time t in the time-domain to the flow that is scheduled on the link λ_j at that time. Further, $S_{\lambda_j}(t) = \infty$ if λ_j is idle at time t .* □

We use the Iverson bracket to indicate whether a flow f_i is scheduled on a link λ_j at time t .³ For convenience, we use $S_{\Lambda_j}(t)$ to indicate the ordered set of schedules $\{S_{\lambda_k}(t) \mid \lambda_k \in \Lambda_j\}$. Moreover, we abbreviate our notation to a single value, i.e., $S_{\Lambda_j}(t) = i$ to denote that all links in Λ_j schedule flow f_i at time t .

Definition 4. *A schedule S implements the SP² if for all $t \geq 0$, for each static routing path Λ_i of every flow f_i , the following implication holds:*

$$(S_{\lambda_k}(t) = i \text{ for some } \lambda_k \in \Lambda_i) \implies S_{\Lambda_j}(t) = i$$

□

In general, the SP² can be implemented with different strategies. The focus of this paper is not the implementation or design of scheduling strategies to meet the schedule defined in Definition 4. In the upcoming two subsections, we discuss two potential scheduling strategies that can be used to derive such schedules.

A. Links to Gang Scheduling

To meet the deadline of a message of a flow f_i , that arrives at time t , the concept of the SP² requires to have $C_i + \eta_i - 1$ time units to use all the links in Λ_i simultaneously before $t +$

³ $[S_{\lambda_j}(t) = i]$ is 1 if f_i is scheduled on λ_j at time t and is 0 otherwise.

D_i . This is similar to the **rigid gang scheduling** problem [10], which can be defined as follows:

- We are given a set of periodic/sporadic tasks to be executed on the given machines.
- Each task has to simultaneously use a subset of the given machines as a **gang**. Whenever the task is executed, all of its required machines must be exclusively allocated to the task.

That is, we can consider that each of the links in Λ is a machine and each flow is a task. The links in Λ_i form a gang for flow f_i and the execution time is $C_i + \eta_i - 1$.

Finding the optimal schedule for the rigid gang scheduling problem has been shown NP-hard in the strong sense even when all the tasks have the same period and the same deadline [24]. Moreover, even special cases, like three machines [4] or unit execution time per task [14], are also NP-hard in the strong sense. The rigid gang scheduling problem for implicit-deadline periodic real-time task systems (i.e., $D_i = T_i$ for every task τ_i) has been recently studied by Goossens and Richard [10]. They presented two algorithms, one is based on linear programming and another is based on a heuristic algorithm. Moreover, Harde et al. [12] constructed static schedules by using a constrained-programming or an integer-linear-programming (ILP) approach for harmonic real-time task systems. Another version of gang scheduling is the so-called *global gang scheduling problem* [8], [21], [34], in which the set of machines used by a gang task is not fixed. A gang task requires a certain amount of machines, and these machines can be dynamically relocated at runtime. We note that the global gang scheduling problem is *unrelated* to the SP², since the links used by a flow has to be defined from the source node to the destination node.

B. Work-Conserving Priority-Based Schedules

Instead of optimizing the scheduling strategies in the routers in a NoC for the SP², we will focus on the work-conserving priority-based SP². Such strategies can be dynamic-priority algorithms (i.e., two messages of flow f_i may have different priorities) and fixed-priority scheduling algorithms (i.e., all messages of flow f_i have the same priority).

That is, each message has a priority. When two messages intend to use one link at the same time, the higher-priority message is scheduled and the lower-priority message is suspended. Whenever a message is suspended in one of its links, it is suspended in all of its links.

We will focus on fixed-priority scheduling in the remainder of this paper. We will focus on the theoretical benefit of the Simultaneous Progressing Switching Protocols in Section V.

V. SP² SCHEDULING ANALYSIS

For a scheduling protocol A , a real-time schedulability analysis of a flow set \mathbf{F} validates whether no flow in the flow set misses its deadline under any valid schedule generated by A . Such a validated flow set is hence called *feasibly schedulable* by A or *infeasible* otherwise. Furthermore, an analysis of a schedulability test for an algorithm A is called *sufficient*

if all flow sets that are deemed to be feasibly schedulable by this test are actually feasibly schedulable. Likewise the test is called *necessary*, if every flow set that is schedulable by algorithm A is verified to be feasibly schedulable by the corresponding schedulability test. Hence, a *necessary* and *sufficient* schedulability test is called *exact*. In the remainder of this paper, we will derive a sufficient schedulability test.

For each flow under analysis, we partition all other flows into a direct contention domain and an indirect contention domain. We define a (direct) contention domain of two flows by identifying the set of higher-priority flows that share at least one link and thus potentially directly interfere with each other. Then, we consider the (indirect) contention domain of the flow under analysis, i.e., flows that do not directly share a link with this flow under analysis but interfere with flows in the (direct) contention domain. In the remainder of this paper, we implicitly assume that the flow set is indexed such that a flow f_i has higher priority than a flow f_j if $i < j$.

In this section, we explain how the schedulability analysis for preemptive fixed-priority Simultaneous Progressing Switching Protocols can be related to the work-conserving fixed-priority preemptive uniprocessor self-suspension scheduling problem. In real-time scheduling theory, self-suspension denotes the property of an executable entity to be exempted from the scheduling decisions for a specified amount of time, i.e., *self-suspension* time. In our analysis, we use self-suspension to model a flow f_j that is eligible to be scheduled using any work-conserving algorithm at a given time t due to being the highest-priority flow and being active (released and not yet finished), but is not transmitted due to indirect contention. We prove that this (indirect) contention can be related to self-suspension behaviour in uniprocessor real-time scheduling theory and thus show the applicability of existing self-suspension aware schedulability analyses. We formally define and prove the self-suspension equivalent property of fixed-priority scheduling using the SP².

We only briefly introduce the uniprocessor self-suspension problem and refer the reader to the existing literature [6], [7] for further information. In short, self-suspension refers to the exemption of a ready schedulable entity from the scheduling decision for a certain amount of time. This exemption behavior is modeled as dynamic self-suspension and multi-segment self-suspension in the literature. In the former, the suspension pattern can be arbitrary and is only parametrically upper bounded by the total self-suspension time. This flexibility comes at the cost of more pessimism in the timing analyses. In the latter model, an upper bound of the duration and the number of a task's suspension intervals is known and can thus be used in the timing analyses. In this paper, we consider the dynamic self-suspension model and the corresponding timing analyses.

Example 1 (Self-Suspension Behaviour). In Figure 3, three priority ordered flows f_1, f_2, f_3 that transmit 20, 19, and 29 flits respectively through the subset of routers V_1, V_2, V_3 , and V_6 as illustrated Figure. 1. Flow f_1 has the highest priority

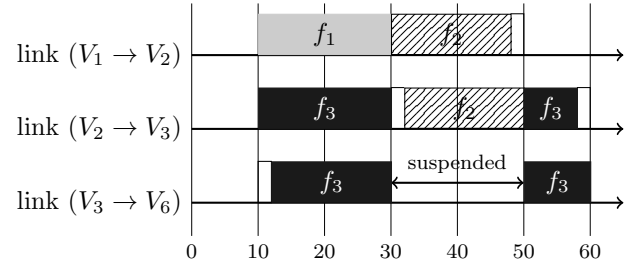

Fig. 3: An exemplary self-suspension instance for three flows using the SP² and fixed-priority scheduling. The empty rectangles are the time allocated for f_2 and f_3 but not used for transmission since there is no available flit yet.

and f_3 has the lowest priority. Flow f_1 transmits from V_1 to the router V_2 , flow f_2 transmits from router V_1 through V_2 to V_3 . Moreover, flow f_3 transmits from V_2 through the router V_3 to V_6 . In this example, all flows are released synchronously and are scheduled according to Simultaneous Progressing Switching Protocols using fixed-priority scheduling. Note that an actual transmission of a flit is denoted by a darkened box whereas the unfilled areas indicate the flows that are granted that link. On the link from V_1 to V_2 , flow f_1 precedes flow f_2 due to its higher priority. Since f_3 does not share any link with f_1 , flow f_3 can transmit on its links. After the finishing of f_1 , flow f_2 attempts to transmit on its links and preempts flow f_3 on the link from V_2 to V_3 . Due to the SP², f_3 is not eligible to transmit on the link from V_3 to V_6 despite being the highest-priority flow on that link. Since the preemption by f_2 is transparent on that link, this behaviour is similar to the self-suspension property of real-time tasks. \square

To formalize the direct contention domain of a flow f_i under analysis, we denote the set of higher-priority flows of f_i that share at least one link as $share_i = \{f_j \in \mathbf{F} \mid j < i, \Lambda_j \cap \Lambda_i \neq \emptyset\}$. Under the fixed-priority SP², each flow has a priority, assumed to be unique here. In our analysis in this section, we assume work-conserving fixed-priority arbitration:

- a flow transmits further if none of its link is used by any higher-priority flow, and
- a flow does not transmit further if one of its link is allocated by another higher-priority flow.

Note that we analyze the schedulability of each flow individually under the assumption that the schedulability of all higher-priority flows has already been validated. In order to formally quantify the times t such that a flow f_j is eligible to transmit on all links in Λ_i in-parallel using Simultaneous Progressing Switching Protocols but is not transmitting, i.e., self-suspension behaviour, we give the following definition.

Definition 5. A flow f_j is said to be Λ_i -self-suspended at a time t , if the following conditions are satisfied:

Prop. 1: f_j is active, i.e., released and not yet finished at time t

Prop. 2: f_j is the highest-priority flow on all the links in Λ_i , i.e., $\min\{S_{\Lambda_i}(t)\} > j$

Prop. 3: $\Lambda_i \supsetneq \Lambda_j$ and $\Lambda_i \cap \Lambda_j \neq \emptyset$, i.e., Λ_j is a true non-empty subset of Λ_i

Prop. 4: for all $\lambda_k \in \Lambda_i$ $S_{\lambda_k}(t) \neq j$ at time t , i.e., f_j is not scheduled on all the links \square

Note that we require $\Lambda_i \neq \Lambda_i$, since the self-suspension like behaviour can only occur due to contention that is transparent to the flow under analysis. In the following theorem, we formally bound the set of flows that exhibit self-suspension behaviour in order to safely account for the additional interference.

Lemma 1. *Let a flow f_j satisfy the properties $f_j \in \text{share}_i$ and for all $f_n \in \text{share}_j : \Lambda_i \cap \Lambda_n \neq \emptyset$ then it follows that $f_n \in \text{share}_i$.*

Proof. This simply comes from the definitions. By the first property, it follows that $j > i$ and $\Lambda_j \cap \Lambda_i \neq \emptyset$. The second property implies that $\forall f_n, n > j$ such that $\Lambda_n \cap \Lambda_j \neq \emptyset$, the condition $\Lambda_i \cap \Lambda_n \neq \emptyset$ holds, which implies that $f_n \in \text{share}_i$. \square

Theorem 1. *In a schedule that is generated by any fixed-priority algorithm using Simultaneous Progressing Switching Protocols, the set of flows that are Λ_i -self-suspending is not larger than*

$$\text{SS}(\Lambda_i) = \{f_\ell \in \text{share}_i \mid \exists f_n \in \text{share}_\ell : \Lambda_n \cap \Lambda_i = \emptyset\}.$$

Proof. We prove this theorem by contrapositive, i.e., we show if $f_j \notin \{f_\ell \in \text{share}_i \mid \exists f_n \in \text{share}_\ell : \Lambda_n \cap \Lambda_i = \emptyset\}$ then f_j is not Λ_i -self-suspending. Therefore, we must analyze the following two cases:

- 1) $f_j \notin \text{share}_i$,
- 2) $f_j \in \text{share}_i$ and $\forall f_n \in \text{share}_j : \Lambda_i \cap \Lambda_n \neq \emptyset$.

In the first case, let $f_j \notin \text{share}_i$ and thus by definition $\Lambda_j \cap \Lambda_i = \emptyset$. Therefore, f_j is not Λ_i -self-suspending at any time t by definition.

In the second case, assume the existence of a time instant t^* such that f_j is Λ_i -self-suspended at time t^* and satisfies the properties stated in the second case. Then, f_i is active at time t^* and for all $\lambda_k \in \Lambda_i$ either $S_{\lambda_k}(t^*) = 0$ or $S_{\lambda_k}(t^*) > j$. Further, by the properties stated for the second case and the results from Lemma. 1, we know that flow $f_n \in \text{share}_i$. This is a contradiction, because no flow f_n could have been active at time t^* since otherwise the schedule would have been $S_{\lambda_k}(t^*) = n$ for all $\lambda_k \in \Lambda_i$ and $n < j$. \square

For further analysis, it is required to bound the maximal amount of time a flow f_j may be Λ_i -self-suspending.

Theorem 2. *Let each higher-priority flow f_j of the flow under analysis f_i be feasibly schedulable using Simultaneous Progressing Switching Protocols. Then, the cumulative amount of time that f_j is Λ_i -self-suspending is at most $R_j - C_j$, where R_j denotes the worst-case response-time of flow f_j .*

Proof. We consider the following two cases:

- 1) Flow f_j is not Λ_i -self-suspending and thus the self-trivially upper bounded by $R_j - C_j$.
- 2) There exists at least one point in time $t \geq 0$ such that f_j is Λ_i -self-suspending.

Let $S_j = \{t \in [t_j, t_j + R_j) \mid f_j \text{ is } \Lambda_i\text{-self-suspending}\}$ where t_j denotes the release of a packet of f_j . By Definition. 5, we know that f_j satisfies Prop. 1 - Prop. 4 at time t for all $t \in S_j$. Furthermore, since $\Lambda_i \cap \Lambda_j \neq \emptyset$ (Prop. 3) and by the *all-or-nothing* property of Simultaneous Progressing Switching Protocols, it must be that $[S_{\Lambda_j}(t) = j] = 0$.

Since by assumption, the schedulability of each higher-priority flow has already been validated, f_j is feasibly schedulable, i.e., $\int_{t_j}^{t_j + R_j} 1 - [S_{\Lambda_j}(\tau) = j] d\tau = R_j - C_j$. Due to the SP² property, we know that all t that satisfy $(1 - [(S_{\Lambda_i}(t) = j)]) = 1$ also satisfy $(1 - [(S_{\Lambda_j}(t) = j)]) = 1$. In conclusion, we have that $\int_{t \in S_j} 1 - [(S_{\Lambda_i}(\tau) = j)] d\tau \leq \int_{t \in S_j} 1 - [S_{\Lambda_j}(\tau) = j] d\tau \leq R_j - C_j$ which concludes the proof. \square

Corollary 1. *A sporadic constrained-deadline flow set \mathbf{F} is fixed-priority schedulable using Simultaneous Progressing Switching Protocols, if for each flow f_i the transformed higher-priority flow set:*

$$f'_j = \begin{cases} (C_j, T_j, D_j, S_j) & f_j \in \text{SS}(\Lambda_i) \\ (C_j, T_j, D_j) & \text{otherwise,} \end{cases} \quad (1)$$

is schedulable, where $S_j = R_j - C_j$.

The worst-case response time and schedulability of each flow f_k has to be verified under the assumption that the higher-priority flows f_1, f_2, \dots, f_{k-1} are already verified to be schedulable. Based on Corollary 1, any schedulability test that verifies the schedulability of sporadic constrained-deadline self-suspending task sets on uniprocessor systems with preemptive fixed-priority scheduling can be used, e.g., the state-of-the-art tests by Chen et al. [6].

VI. ANALYTICAL ADVANTAGES OF SP²

In this section we shortly compare our fixed-priority SP² and schedulability analysis with some of the state-of-the-art fixed-priority schedulability analyses for wormhole-switching NoC with virtual channels proposed by Xiong et al. [43] and Indrusiak et al. [16]. Unfortunately, we have to admit to not be able to comprehend the analyses presented by Nikolíc et al. [30] and are thus incapable to compare with their methods analytically. We note that we do not intend to directly compare the state-of-the-art analyses due the different protocols and models but to only exemplify the analytical gains and benefits of the SP² compared to one-hop scheduling protocols.

Let share_k be the set of higher-priority flows whose routing path intersects with the routing path of f_k . Let share_k^1 be $f_j \in \{\text{share}_k \setminus \{f_\ell \in \text{share}_k \mid \text{share}_\ell \setminus \text{share}_k = \emptyset\}\}$. This notation follows [30]. In the plaintext, share_k^1 consists of the flows in share_k by excluding those flows f_ℓ in which higher-priority flows that intersect with f_ℓ , i.e., share_ℓ are also in share_k . This means that if f_ℓ is in share_k^1 , then f_ℓ is in share_k and there exists one flow f_n that is not in share_k but

in $share_\ell$. Therefore, this notation is exactly $\mathbf{SS}(\Lambda_k)$ defined in Theorem 1, i.e.,

$$\mathbf{SS}(\Lambda_k) = share_k^1$$

According to Eq. (4) and Eq. (5) in [30], the analyses of the worst-case response time for *preemptive worm-hole switching* from [16], [43] can be computed by solving the minimum value $t > 0$ of the following function:⁴

$$t = C_k + \sum_{f_j \in share_k} \left\lceil \frac{t + J_{j \rightarrow i}^I}{T_j} \right\rceil \cdot (C_j + B_{j \rightarrow i}) \quad (2)$$

where $B_{j \rightarrow i} \geq 0$ is the interference due to buffering, i.e., backpressure, and

$$J_{j \rightarrow i}^I = \begin{cases} R_j - C_j & \text{if } f_j \in share_k^1, \\ 0 & \text{otherwise.} \end{cases} \quad (3)$$

Now, we consider the following response time analysis from Chen et al. in [6]:⁵

$$t = C_k + S_k + \sum_{i=1}^{k-1} \left\lceil \frac{t + Q_i^{\vec{x}} + (1 - x_i)(R_i - C_i)}{T_i} \right\rceil C_i \quad (4)$$

where $Q_i^{\vec{x}} = \sum_{j=i}^{k-1} (S_j \times x_j)$ and for a certain binary assignment of $x_i \in \{0, 1\}$ for $i = 1, 2, \dots, k-1$.

According to Corollary 1 and $\mathbf{SS}(\Lambda_k) = share_k^1$, we have $S_j = R_j - C_j$ if $f_j \in share_k^1$ and $S_j = 0$ if $f_j \notin share_k^1$. Moreover, since f_k is not in $\mathbf{SS}(\Lambda_k)$, we have $S_k = 0$. If f_j is in $share_k^1$, we set x_j to 0; otherwise, we set x_j to 1. In such a setting of \vec{x} , the value $Q_i^{\vec{x}}$ in Eq. (4) is always 0. Together with $S_k = 0$ by definition and the definition in Eq. (3), the analysis in Eq. (4) becomes:

$$\begin{aligned} t &= C_k + \sum_{f_j \in \mathbf{SS}(\Lambda_k)} \left\lceil \frac{t + R_j - C_j}{T_j} \right\rceil C_j + \sum_{f_j \in share_k \setminus \mathbf{SS}(\Lambda_k)} \left\lceil \frac{t}{T_j} \right\rceil C_j \\ &= C_k + \sum_{f_j \in share_k^1} \left\lceil \frac{t + R_j - C_j}{T_j} \right\rceil C_j + \sum_{f_j \in share_k \setminus share_k^1} \left\lceil \frac{t}{T_j} \right\rceil C_j \\ &= C_k + \sum_{f_j \in share_k} \left\lceil \frac{t + J_{j \rightarrow i}^I}{T_j} \right\rceil C_j \\ &\leq C_k + \sum_{f_j \in share_k} \left\lceil \frac{t + J_{j \rightarrow i}^I}{T_j} \right\rceil (C_j + B_{j \rightarrow i}) = \text{RHS of Eq.(2)} \end{aligned}$$

Therefore, the worst-case response time analysis from [16], [43] is dominated by our analysis from Corollary 1 by applying suspension-aware response time analysis from Chen et al. [6].

VII. IMPLEMENTATION CONSIDERATIONS

The architectural implementation of the priority-based Simultaneous Progressing Switching Protocols (SP²) providing the *all-or-nothing* property requires to rethink previous router

⁴The term J_j^R in Eq. (4) in [30] is removed here since we consider sporadic flows without release jitter.

⁵For notational consistency with [6], we here use the notation from [6] for self-suspending task systems and assume that there are $k-1$ higher-priority flows in $share_k$.

designs. In the state-of-the-art wormhole switching protocols, the decision at each router is local, i.e., each router simply chooses the highest-priority flow on any outgoing link. In contrast, the *all-or-nothing* property requires global decision making.

The SP² is a general concept, and there could be different possible realizations. One possibility is to use centralized arbitration which decides and dispatches the priority information to the routers. However, this may incur high hardware cost. Possible implementations are subject of future research efforts and beyond the conceptual scope of this paper.

VIII. CONCLUSION

In this paper, we discuss the fundamental difficulty of worst-case timing analysis of flit-based pipelined transmissions over multiple links in-parallel in network-on-chips. The space of possible *progression states* that need to be covered by an analysis hints to the mismatch with uniprocessor scheduling theory and their assumptions, thus making analyses complex and prone to being optimistic. To that end, we propose *Simultaneous Progressing Switching Protocols* (SP²), in which the links used by a message *either* all simultaneously transmit one flit of this message *or* none of them transmits any flit of this message. For this family of protocols, we formally prove the matching with uniprocessor scheduling assumptions and theory. Furthermore, we show the relation between the uniprocessor self-suspension scheduling problem and the SP² scheduling and provide formal proofs to confirm this relation. In addition, we provide a sufficient schedulability analysis for fixed-priority SP² scheduling.

We note that the existing link-based switching and the proposed SP² are in fact two extreme scenarios with respect to the series of progressions. The SP² approach always results in the fastest series of progressions in any case by sacrificing the possibility to send part of the messages even when only one link is blocked by another higher-priority message/flow. The link-based switching mechanism (worm-hole protocol) allows the flexibility to send only one flit of a flow forward at a time unit in the NoC, but it has to potentially consider the slowest series of progressions of the flow in the worst case. It may be possible to design timing predictable systems with good average-case performance by pruning unnecessary progressions that have to be considered in the protocol. However, this alternative was not considered in this paper.

We strongly believe that a timing-predictable switching protocol in NoCs should be carefully designed so that NoC-based many-core systems can yield predictable performance. This paper provides protocols that can be implemented with different strategies. We believe that our proposals can be a first step towards predictable switching protocols of NoCs. In our future work, we will explore possible design options and their tradeoffs in the schedulability analyses and design complexity/cost.

REFERENCES

- [1] L. Abdallah, M. Jan, J. Ermont, and C. Fraboul. Wormhole networks properties and their use for optimizing worst case delay analysis of many-cores. In *Proc. of the 10th IEEE International Symposium on Industrial Embedded Systems (SIES 2015)*, pages 1–10, June 2015.
- [2] P. Axer, R. Ernst, H. Falk, A. Girault, D. Grund, N. Guan, B. Jonsson, P. Marwedel, J. Reineke, C. Rochage, M. Sebastian, R. V. Hanxleden, R. Wilhelm, and W. Yi. Building timing predictable embedded systems. *ACM Trans. Embed. Comput. Syst.*, 13(4):82:1–82:37, Mar. 2014.
- [3] H. Ayed, J. Ermont, J.-I. Scharbag, and C. Fraboul. Towards a unified approach for worst-case analysis of tilera-like and kalray-like noc architectures. In *World Conf. on Factory Communication Systems (WFCS), WiP Session*, Aveiro, Portugal, May 2016. IEEE.
- [4] J. Błażewicz, P. Dell’Olmo, M. Drozdowski, and M. Speranza. Corrigendum to: Scheduling multiprocessor tasks on three dedicated processors. *Inf. Process. Lett.*, 49(5):269–270, 1994.
- [5] M. Boyer, B. Dupont de Dinechin, A. Graillat, and L. Havet. Computing routes and delay bounds for the network-on-chip of the kalray mppa2 processor. In *Proc. of the 9th European Congress on Embedded Real Time Software and Systems (ERTS² 2018)*, 2018.
- [6] J.-J. Chen, G. Nelissen, and W.-H. Huang. A unifying response time analysis framework for dynamic self-suspending tasks. In *Euromicro Conference on Real-Time Systems (ECRTS)*, pages 61–71, 2016.
- [7] J.-J. Chen, G. Nelissen, W.-H. Huang, M. Yang, B. Brandenburg, K. Bletsas, C. Liu, P. Richard, F. Ridouard, N. Audsley, R. Rajkumar, D. de Niz, and G. von der Brüggén. Many suspensions, many problems: a review of self-suspending tasks in real-time systems. *Real-Time Systems*, Sep 2018.
- [8] Z. Dong and C. Liu. Analysis techniques for supporting hard real-time sporadic gang task systems. In *IEEE Real-Time Systems Symposium, RTSS*, pages 128–138, 2017.
- [9] F. Giroudot and A. Mifdaoui. Buffer-aware worst-case timing analysis of wormhole nocs using network calculus. In *Real-Time and Embedded Technology and Applications Symposium, (RTAS)*, pages 37–48, 2018.
- [10] J. Goossens and P. Richard. Optimal scheduling of periodic gang tasks. *LITES*, 3(1):04:1–04:18, 2016.
- [11] K. Goossens, J. Dielissen, and A. Radulescu. Aethereal network on chip: concepts, architectures, and implementations. *IEEE Design Test of Computers*, 22(5):414–421, Sep. 2005.
- [12] T. Harde, M. Freier, G. von der Brüggén, and J.-J. Chen. Configurations and optimizations of TDMA schedules for periodic packet communication on networks on chip. In *International Conference on Real-Time Networks and Systems, RTNS*, pages 202–212, 2018.
- [13] S. L. Hary and F. Ozgüner. Feasibility test for real-time communication using wormhole routing. *IEE Proceedings - Computers and Digital Techniques*, 144(5):273–278, 1997.
- [14] J. Hoogeveen, S. van de Velde, and B. Veltman. Complexity of scheduling multiprocessor tasks with prespecified processor allocations. *Discrete Appl. Math.*, 55(3):259–272, 1994.
- [15] L. S. Indrusiak, A. Burns, and B. Nikolic. Analysis of buffering effects on hard real-time priority-preemptive wormhole networks. *CoRR*, abs/1606.02942, 2016.
- [16] L. S. Indrusiak, A. Burns, and B. Nikolic. Buffer-aware bounds to multi-point progressive blocking in priority-preemptive nocs. In *Design, Automation & Test in Europe Conference & Exhibition, DATE*, pages 219–224, 2018.
- [17] M. Joseph and P. Pandya. Finding Response Times in a Real-Time System. *The Computer Journal*, 29(5):390–395, May 1986.
- [18] E. Kasapaki, M. Schoeberl, R. B. Sorensen, C. T. Muller, K. Goossens, and J. Sparsø. Argo: A real-time network-on-chip architecture with an efficient GALS implementation. *IEEE Trans. VLSI Syst.*, 24(2):479–492, 2016.
- [19] H. Kashif, S. Gholamian, and H. Patel. Sla: A stage-level latency analysis for real-time communication in a pipelined resource model. *IEEE Transactions on Computers*, PP, April 2014.
- [20] H. Kashif and H. Patel. Buffer space allocation for real-time priority-aware networks. In *2016 IEEE Real-Time and Embedded Technology and Applications Symposium (RTAS)*, pages 1–12, April 2016.
- [21] S. Kato and Y. Ishikawa. Gang EDF scheduling of parallel task systems. In *IEEE Real-Time Systems Symposium, RTSS*, pages 459–468, 2009.
- [22] N. Kavaldjiev and G. Smit. A survey of efficient on-chip communications for soc. In *4th PROGRESS Symposium on Embedded Systems*, pages 129–140. STW Technology Foundation, 10 2003. Imported from DIES.
- [23] B. Kim, J. Kim, S. Hong, and S. Lee. A real-time communication method for wormhole switching networks. In *International Conference on Parallel Processing*, pages 527–534, 1998.
- [24] M. Kubale. The complexity of scheduling independent two-processor tasks on dedicated processors. *Inf. Process. Lett.*, 24(3):141–147, 1987.
- [25] J. P. Lehoczky, L. Sha, and Y. Ding. The rate monotonic scheduling algorithm: Exact characterization and average case behavior. In *IEEE Real-Time Systems Symposium’89*, pages 166–171, 1989.
- [26] C.-L. Liu and J. W. Layland. Scheduling algorithms for multiprogramming in a hard-real-time environment. *Journal of the ACM*, 20(1):46–61, 1973.
- [27] Z. Lu, A. Jantsch, and I. Sander. Feasibility analysis of messages for on-chip networks using wormhole routing. In *Asia and South Pacific Design Automation Conference (ASP-DAC)*, volume 2, pages 960–964, 2005.
- [28] M. Millberg, E. Nilsson, R. Thid, and A. Jantsch. Guaranteed bandwidth using looped containers in temporally disjoint networks within the nostrum network on chip. In *Design, Automation and Test in Europe Conference (DATE)*, pages 890–895, 2004.
- [29] M. W. Mutka. Using rate monotonic scheduling technology for real-time communications in a wormhole network. In *Second Workshop on Parallel and Distributed Real-Time Systems*, pages 194–199, 1994.
- [30] B. Nikolić, S. Tobuschat, L. S. Indrusiak, R. Ernst, and A. Burns. Real-time analysis of priority-preemptive nocs with arbitrary buffer sizes and router delays. *Real-Time Systems*, 55(1):63–105, Jan 2019.
- [31] C. Paukovits and H. Kopetz. Concepts of switching in the time-triggered network-on-chip. *2008 14th IEEE International Conference on Embedded and Real-Time Computing Systems and Applications*, pages 120–129, 2008.
- [32] Y. Qian, Z. Lu, and W. Dou. Analysis of worst-case delay bounds for best-effort communication in wormhole networks on chip. In *International Symposium on Networks-on-Chip*, pages 44–53, 2009.
- [33] E. A. Rambo and R. Ernst. Worst-case communication time analysis of networks-on-chip with shared virtual channels. In *Design, Automation & Test in Europe Conference, (DATE)*, pages 537–542, 2015.
- [34] P. Richard, J. Goossens, and S. Kato. Comments on “gang EDF schedulability analysis”. *CoRR*, <http://arxiv.org/abs/1705.05798>, 2017.
- [35] J. B. Schmitt, F. A. Zdarsky, and I. Martinovic. Improving performance bounds in feed-forward networks by paying multiplexing only once. In *14th GI/ITG Conference - Measurement, Modelling and Evaluation of Computer and Communication Systems*, pages 1–15, 2008.
- [36] M. Schoeberl. A time-triggered network-on-chip. In *FPL 2007, International Conference on Field Programmable Logic and Applications, Amsterdam, The Netherlands, 27-29 August 2007*, pages 377–382, 2007.
- [37] M. Schoeberl, S. Abbaspour, B. Akesson, N. C. Audsley, R. Capasso, J. Garside, K. Goossens, S. Hansen, R. Heckmann, S. Hepp, B. Huber, A. Jordan, E. Kasapaki, J. Knoop, Y. Li, D. Prokesch, W. Puffitsch, P. P. Puschner, A. Rocha, C. Silva, J. Sparsø, and A. Tocchi. T-CREST: time-predictable multi-core architecture for embedded systems. *Journal of Systems Architecture - Embedded Systems Design*, 61(9):449–471, 2015.
- [38] Z. Shi and A. Burns. Real-time communication analysis for on-chip networks with wormhole switching. In *Proceedings of the Second ACM/IEEE International Symposium on Networks-on-Chip (NOCS)*, pages 161–170, 2008.
- [39] R. Stefan, A. Molnos, A. Ambrose, and K. Goossens. A tdm noc supporting qos, multicast, and fast connection set-up. In *Proceedings of the Conference on Design, Automation and Test in Europe, DATE ’12*, pages 1283–1288, 2012.
- [40] S. Tobuschat and R. Ernst. Real-time communication analysis for networks-on-chip with backpressure. In *Design, Automation & Test in Europe Conference & Exhibition, (DATE)*, pages 590–595, 2017.
- [41] R. Wilhelm, D. Grund, J. Reineke, M. Schlickling, M. Pister, and C. Ferdinand. Memory hierarchies, pipelines, and buses for future architectures in time-critical embedded systems. *IEEE Trans. on CAD of Integrated Circuits and Systems*, 28(7):966–978, 2009.
- [42] Q. Xiong, Z. Lu, F. Wu, and C. Xie. Real-time analysis for wormhole noc: Revisited and revised. In *2016 International Great Lakes Symposium on VLSI (GLSVLSI)*, pages 75–80, May 2016.
- [43] Q. Xiong, F. Wu, Z. Lu, and C. Xie. Extending real-time analysis for wormhole nocs. *IEEE Transactions on Computers*, 66(9):1532–1546, Sept 2017.