

SAFE^d: Self-Attestation For Networks of Heterogeneous Embedded Devices

Alessandro Visintin
visintin@math.unipd.it
University of Padua
Italy

Mauro Conti
conti@math.unipd.it
University of Padua
Italy

Flavio Toffalini
flavio_toffalini@mymail.sutd.edu.sg
Singapore University of Technology and Design
Singapore

Jianying Zhou
jianying_zhou@sutd.edu.sg
Singapore University of Technology and Design
Singapore

ABSTRACT

The Internet of Things (IoT) is an emerging paradigm that allows to set large networks of small and independent devices. To ensure their integrity, practitioners employ so-called Remote Attestation (RA) schemes. Classic RA schemes require a central and powerful entity, called Verifier, that has mainly two duties: (i) it manages the entire process of attestation, and (ii) it contains all the proofs for validating the devices' integrity. However, having a central Verifier makes the network dependent upon an external entity and introduces a single point of failure for security.

In this work, we propose SAFE^d: the first RA schema that allows a pair of IoT devices to validate their integrity without relying on an external Verifier. Our approach overcomes previous limitations by spreading the proofs among multiple IoT devices and using novel cryptographic mechanisms to ensure secure communications. Moreover, the entire IoT network can collaboratively isolate tampered devices and recover missing proofs in case of anomalies.

We evaluate our schema through an implementation for Raspberry Pi platform and a network simulation. The results show that SAFE^d can detect infected devices and recover up to 99.9% of proofs in case of faults or attacks. Moreover, we managed to protect up to 10K devices with a logarithmic overhead on the network and on the devices' memory.

CCS CONCEPTS

• **Security and privacy** → **Security protocols**; *Trusted computing*.

KEYWORDS

security, distributed hash table, chord protocol, remote attestation

ACM Reference Format:

Alessandro Visintin, Flavio Toffalini, Mauro Conti, and Jianying Zhou. 2018. SAFE^d: Self-Attestation For Networks of Heterogeneous Embedded Devices. In *Woodstock '18: ACM Symposium on Neural Gaze Detection, June 03–05, 2018, Woodstock, NY*. ACM, New York, NY, USA, 12 pages. <https://doi.org/10.1145/1122445.1122456>

1 INTRODUCTION

Internet of Things (IoT) refers to a set of new technologies that allow building sophisticated applications by using groups of small and interconnected devices. IoT world revolves around three cardinal concepts: (i) a decentralized network which can be accessed remotely through the Internet, (ii) heterogeneous devices that collaborate autonomously, and (iii) interaction with the physical environment via sensors and actuators. This paradigm has several applications that range from industrial control systems [31] to small home-appliances [33].

To enhance the security guarantees of IoT networks, practitioners use Remote Attestation (RA) schemes that allow a trusted entity (*i.e.*, *Verifier*) to validate the hardware and software integrity (*i.e.*, verifies) of a remote one (*i.e.*, *Prover*) without the need of manual inspection. The *Verifier* sends a challenge to the *Prover* and receives a measurement of its status as a report (*e.g.*, an application fingerprint). The *Verifier* then compares the measurement with a database of *proofs* previously saved to check the correctness of the *Prover* status. This approach, often defined as *single-Verifier RA*, is well-established but assumes a *Verifier* with powerful capabilities and physically isolated from the network, thus protected against any threat (*e.g.*, a remote server in a controlled area). The *Prover*, instead, might be any device inside the network and can be tampered by a potential attacker. These assumptions, however, are incompatible in a scenario of independent IoT networks in which the devices cannot rely on an external *Verifier* for the attestation process. Moreover, an IoT network is usually composed by devices that are equipped with different hardware and run different applications. A naive solution for removing a central *Verifier* might be to keep a copy of all the *proofs* inside each device. However, this is not practical due to the resource constraints imposed by IoT devices themselves. Moreover, a dynamic network is composed by devices which continuously leave and enter the network itself, thus introducing additional *proofs*-management challenges.

Permission to make digital or hard copies of all or part of this work for personal or classroom use is granted without fee provided that copies are not made or distributed for profit or commercial advantage and that copies bear this notice and the full citation on the first page. Copyrights for components of this work owned by others than ACM must be honored. Abstracting with credit is permitted. To copy otherwise, or republish, to post on servers or to redistribute to lists, requires prior specific permission and/or a fee. Request permissions from [permissions@acm.org](https://permissions.acm.org).

Woodstock '18, June 03–05, 2018, Woodstock, NY

© 2018 Association for Computing Machinery.

ACM ISBN 978-1-4503-XXXX-X/18/06... \$15.00

<https://doi.org/10.1145/1122445.1122456>

First solutions for autonomous networks were recently proposed with [2, 19, 22]. However, we found some limitations in these works. In [2], the authors rely on heuristics and consider only homogeneous devices, while in [19, 22], they do not fully address scalability and still suffer from single point-of-failure issues. We provide more details in Section 2.

In this paper, we propose SAFE^d: the first concrete RA schema for autonomous networks of heterogeneous embedded devices. SAFE^d introduces a new approach that enables any IoT device in a network to validate the integrity of another random device without the need for a central *Verifier*. To achieve this goal, we design new solutions that fits the IoT realm. The main concept regards the decentralization of the *Verifier*'s duties by making all the network active during the attestation process. The distributed nature of our solution increases the effort required for an attack. To implement our strategy, we built SAFE^d upon a Distributed Hash Tables (DHT) [46] that allows us to manage data structures spread over several entities. For our proof-of-concept, we opted for Chord [36, 37, 45] as DHT implementation, however, SAFE^d is agnostic from the type of DHT protocol chosen. Chord protocol has not been thought to be resilient against compromised devices. Therefore, we developed new solutions to improve DHTs security guarantees and to overcome their limitations. First, we design a new key exchange protocol which is based on Diffie Hellman [35] and is integrated inside the Chord mechanisms. It allows to issue a secure communication between any pair of devices inside the network without having to store cryptographic keys or using additional exchanged messages. Second, we improve data resilience by using parallel DHT instances (called *overlays*) that replicate the *proofs* in different and random devices. This avoids an attacker to infer the *proofs* position inside the network. Our schema requires every device to be equipped with small trusted anchors [24], which contain and protect the algorithms required to SAFE^d.

We implemented SAFE^d in the open-source Raspberry Pi 3 platform. We chose this solution because its chip supports ARM TrustZone [43], which is a standard trusted anchor largely used in other works [15, 24, 25]. Moreover, we performed a large-scale experimentation by simulating networks of 10K virtual devices through Omnet++ [41]. To validate our approach, we conducted several attacks against both the platforms, encompassing software tampering, lost packets and corrupted devices. SAFE^d recovered up to 99.9% of lost *proofs* and showed a logarithmic communication overhead and memory footprint.

SAFE^d overcomes previous attestation solutions for network of IoT devices because its performances are not affected by the number of devices connected and it completely removes single point-of-failure by design. Furthermore, solid experimental results are proposed to support our claims. We believe that SAFE^d will help developing more resilient networks of IoT devices and secure DHTs.

To sum up, SAFE^d is a novel collaborative attestation for networks of heterogeneous IoT devices that introduces the following contributions:

- **No single point of failure:** the *proofs* are randomly spread inside the network, thus increasing the difficulty for an attacker to corrupt the attestation process.

- **Self-protection:** the network can identify and react against corrupted devices.
- **Resilient network:** SAFE^d can recover its *proofs* in case of lost data or attacks.
- **Scalability:** the protocol can manage a large number of devices with minimal footprint.

The open-source proof-of-concept implementation of SAFE^d for Raspberry Pi 3 will be available at the link ¹.

2 RELATED WORK

2.1 Remote Attestation for IoT Networks

The first attestation proposal for autonomous network was introduced by Abera et al. with DIAT [2]. In this work, the authors assume a network of homogeneous devices (e.g., a swarm of drones), which validate their own status without using a central *Verifier*. However, they mainly focus on runtime RA (i.e., they validate runtime device status) by using heuristics. In addition, they require a network of homogeneous devices. On the contrary, SAFE^d is based on analytical results and it can handle networks of heterogeneous devices in an autonomous fashion.

PASTA [22] is the first work that tries to spread the burden of verification across the entire network. In PASTA, the *Provers* periodically collaborate to generate the so-called *tokens*. Every *token* attests the integrity of all the nodes that participated in its generation and contains a timestamp to allow absence detection of a particular node. *Tokens* are validated using an aggregated signature built on a Schnorr-based multisignature scheme. However, we found some limitation to their approach since they require that each device maintains all the private keys of its neighbors, thus limiting the scalability. On the contrary, SAFE^d enables any pair of devices to issue a trusted channel without any pre-shared information.

Another line of research attempts to measure the integrity of the network through a single challenge/response interaction [6, 8, 13]. The common trait of these works is the logical organization of the devices using a spanning tree topology. An external *Verifier* initiates the attestation process and collects a cumulative response from the entire network. On the contrary, SAFE^d faces a different scenario and does not require a central *Verifier* to perform an attestation.

Other works investigate cumulative RA schemes to detect physical attacks [19–21, 44]. The intuition behind these solutions is that an adversary needs to remove a device from the network to perpetrate an attack, thus causing a temporary disconnection. In particular, Ibrahim et al. proposed US-AID [19] which combines continuous in-network attestation and Proofs-of-non-Absence to detect both software tampering and device disconnections. However, they require a reliable read-only clock (RROC) to achieve physical attacks detection. Yan et al. improved the work of Ibrahim by introducing EAPA [44], which performs RA physical attack resilient in a faster manner. SAFE^d, instead, can detect physical attacks directly using communication timeouts by design.

To sum up, SAFE^d overcomes previous related RA schemes for mainly three reasons: (i) we fully remove any central trusted authority in the network, (ii) we efficiently spread the proofs among

¹We are willing to share the source code with the community upon acceptance or to provide it to the reviewers upon request via conference chairs

the nodes, (iii) we do not rely on synchronized clocks for absence detection.

2.2 Distributed Hash Tables

In general, all DHTs have been designed to decentralize information (e.g., a file) and improve network performances and robustness. Furthermore, they are thought to be deployed in large networks, such as the Internet. However, these protocols do not consider security issues in their design. In the last years, researchers investigated security limitations of DHTs [17, 23, 32, 34]. These works aim at improving different aspects of DHT protocols, however, they differ from SAFE^d for different reasons:

- **Context:** they assume a large and dynamic network such as the Internet, while we focus on a more restricted physical area. Thus, we can rely on a better control over the devices that compose the network.
- **Attacker model:** they consider dishonest or churn nodes. On the contrary, SAFE^d assumes honest behavior guaranteed by trusted anchors.
- **Defense strategies:** they rely on statistical and cryptographic schema to improve trust in nodes [4]. However, their approaches simply increase the effort required to a potential attacker without resolving the problem by design.

We are the first to tackle DHT security issues in the context of attestation protocols, which is more concrete and practical *w.r.t.* previous works.

Another crucial aspect of DHTs regards the privacy of the data stored inside of it [29, 38]. SAFE^d enhances the privacy constraint and is usually physically protected from attacks (e.g., a remote server). Its duty is to verify the integrity of a *Prover* that may be corrupted (e.g., due to a malware). RA schemes require a *Verifier* to start the protocol by sending a challenge to the *Prover*, which measures some properties of its state (e.g., compute a hash of a piece of software) and returns a report. The *Verifier* is now able to validate the *Prover* status according to the returned report by comparing its value with a database of correct measurements (called *proofs*).

The classic approaches involve static measurements, such as software fingerprint or hardware integrity [16]. More recently, researchers proposed a dynamic type of RA defined dynamic [1, 2, 40], which tries to attest run-time properties such as execution-paths. SAFE^d focuses on static RA. However, we discuss possible dynamic RA integration strategies in Section 8.

3 BACKGROUND

3.1 Remote Attestation

Remote Attestation (RA) schemes refer to those protocols that allow verifying the integrity of a remote entity. Usually, they involve two distinct roles: *Verifier* and *Prover*. The *Verifier* is considered trusted and is usually physically protected from attacks (e.g., a remote server). Its duty is to verify the integrity of a *Prover* that may be corrupted (e.g., due to a malware). RA schemes require a *Verifier* to start the protocol by sending a challenge to the *Prover*, which measures some properties of its state (e.g., compute a hash of a piece of software) and returns a report. The *Verifier* is now able to validate the *Prover* status according to the returned report by comparing its value with a database of correct measurements (called *proofs*).

The classic approaches involve static measurements, such as software fingerprint or hardware integrity [16]. More recently, researchers proposed a dynamic type of RA defined dynamic [1, 2, 40], which tries to attest run-time properties such as execution-paths. SAFE^d focuses on static RA. However, we discuss possible dynamic RA integration strategies in Section 8.

3.2 Trusted Anchor

Modern RA schemes require devices to mount specialized hardware called trusted anchors. These technologies allow to define protected memory regions and build Trusted Execution Environments (TEE). A TEE provides useful functionalities like cryptographic algorithms and secure random number generators. In this work, we opted for ARM TrustZone [43] as trusted anchor due to its flexibility and its wide spread. A device equipped with TEE organizes its memory in two main zones: *untrusted* and *trusted*, respectively known in ARM TrustZone jargon as *normal world* and *secure world*. The *normal world*, as the name suggests, contains the general purpose software needed for running a classic operating system. The *secure world*, instead, contains the code strictly necessary for establishing a trusted execution inside the *normal world*, i.e., the *secure world* checks the execution of the *normal world*.

SAFE^d implementation is placed inside the *secure world* to protect its algorithms and critical variables (e.g., cryptographic keys). These technologies stand as the base of modern RA schema in IoT devices and classic IT infrastructure.

3.3 Chord

Chord [36, 37] is a lookup protocol to establish a DHT and is specifically designed for large peer-to-peer networks. This protocol allows to distribute hash tables (i.e., key/value pairs) over multiple devices. It uses consistent hashing for arranging the nodes in a circle and for distributing the keys among them. Each element (e.g., nodes and keys) is identified by an *m-bit* number computed by a hash function.

Every piece of data is saved inside the first node whose identifier is greater than or equal to its identifier. As a consequence of this setting, a device will store all the piece of data whose ID is between its ID and that of the preceding device. Each node is linked to its *predecessor* and *successor*, thus establishing a ring. To improve resilience, a device also maintains a list of immediate successors, called *successors list*.

Having the devices and data organized in a ring makes possible to implement a look up function as follows: (i) a device *A* sends a request with the data ID to its successor *B*, (ii) if *B* contains the data (i.e., $ID < B$), it is returned to *A*, otherwise it forwards the request to its successor. The step is repeated till finding the ID.

The complexity of this solution is linear with the number of nodes placed inside the ring. To improve the performances, Chord introduces a *finger table* that contains additional routing information. The *finger table* has *m* entries called *fingers*: the *i*-th finger is a reference to the 2^{i-1} position ahead the current node. As a result, the *finger table* allows an average searching complexity of $O(\log_2 N)$, making the look up operation scalable with respect to the number of nodes *N*.

Chord also provides procedures for adding new nodes to the ring and maintaining the order in case of failures. We referred to [45] for the implementation of a simpler yet correct version based on three distinct operations:

- **Join:** an outside node contacts a member of the ring (defined as the *entry*) to know which is its successor. It then contacts its successor to update the successor list.

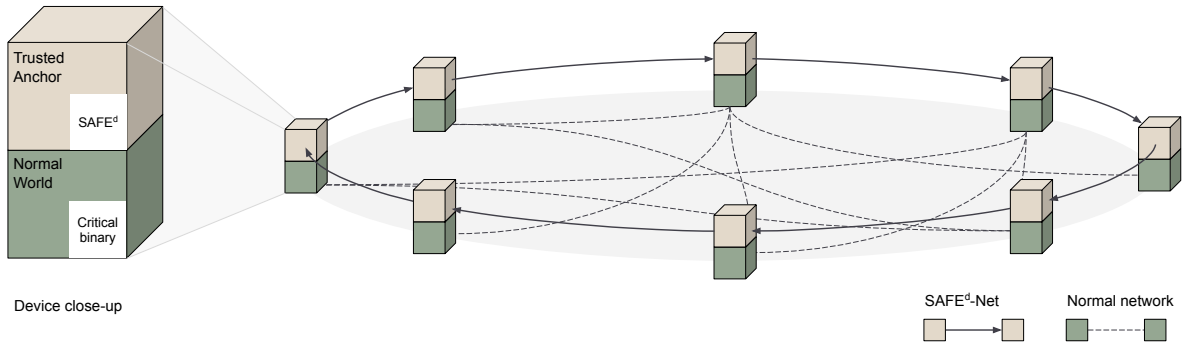

Figure 1: Network architecture (considering a single overlay).

- **Stabilize**: the node asks to its predecessor information about the predecessor. It adopts this predecessor as its new successor if it is actually closer than the current successor in the ring order. In both cases, the node sends a final notification to the successor. The successors list is updated with the information coming from the contacted nodes.
- **Rectify**: in case of a received notification, the node checks if its current predecessor is still alive and then adopts the notifying member as new predecessor if it is closer than the current predecessor or if it has no live predecessor.

A node executes the *join* procedure just when entering the network. *Stabilize* and *rectify* procedures are instead periodically triggered during the protocol routine.

SAFE^d builds on top of an enhanced version of Chord, in which a joining node can save its attestation data inside the network and the routine operations take care of re-distributing the information when new nodes join the ring. More importantly, SAFE^d introduces redundancy of data by running several Chord instances at the same time, thus dealing with the loss of information caused by failures or attacks.

4 ASSUMPTIONS AND THREAT MODEL

4.1 Device Architecture

The devices considered in SAFE^d are equipped with a trusted anchor (*i.e.*, ARM TrustZone), which is considered secure. The *secure world* is physically isolated from the rest of the system and its duties are twofold: (i) inspect and measure the device memory and (ii) communicate with the other trusted anchors in the network. The trusted anchor is used as a secure storage for all the variables needed by SAFE^d and it is protected from an attacker by design. The *normal world* runs different applications and can be compromised.

4.2 Network Context

In this work, we assume networks of fully interconnected devices that range from few elements to 10K devices. Our main use case is for industry, however, we can deploy SAFE^d to any type of autonomous system networks. SAFE^d can handle highly dynamic networks where nodes continuously enter and exit them. However, we allow only known devices to join the network. This is reasonable

since we consider geographically restricted networks (*e.g.*, factories or smart-homes).

4.3 Threat Model

SAFE^d faces attacks that target both the device and the network.

Device Attacks. The goal of the attacker is to load unauthorized binaries or inject malicious code inside the *normal world* by using different strategies, *e.g.*, exploiting security flaws. We consider the *secure world* isolated from the *normal* one and therefore out of the attacker range. We also consider compromised devices that hide their presence in the network and physical attacks.

Network Attacks. An attacker can manipulate network traffic by following classic Dolev-Yao model [14]. Thus she can eavesdrop, insert, modify, delete messages, perform a replay attack, or forge attestation messages.

In general, we do not consider denial-of-service (DoS), however, we evaluate the resilience of SAFE^d in case of unavailable devices. These assumptions are coherent with previous works [2, 6, 8, 13, 19, 22].

5 SAFE^d

SAFE^d is an extension of a DHT that includes new mechanisms for dealing with the adversary described in Section 4.3.

In our schema, the devices are logically organized into two parallel networks (Figure 1). The first one is the normal network (dashed line), used by ordinary applications to communicate with other devices. The second one is SAFE^d-net (solid-line arrows), built on top of the normal network and used by the trusted anchors to perform the schema routines.

SAFE^d-net is composed by a fixed number of *overlays* which is defined at network creation time. Each *overlay* is an independent Chord instance (Section 3.3) that contains all the devices as well as a copy for each *proof*. The purpose of the *overlays* is twofold: (i) the number of *overlays* identifies the redundancy (*i.e.*, X independent *proof* copies requires X *overlays*) and (ii) they help keeping the *proofs* distribution balanced.

The location of objects inside SAFE^d-net is managed through two types of ID:

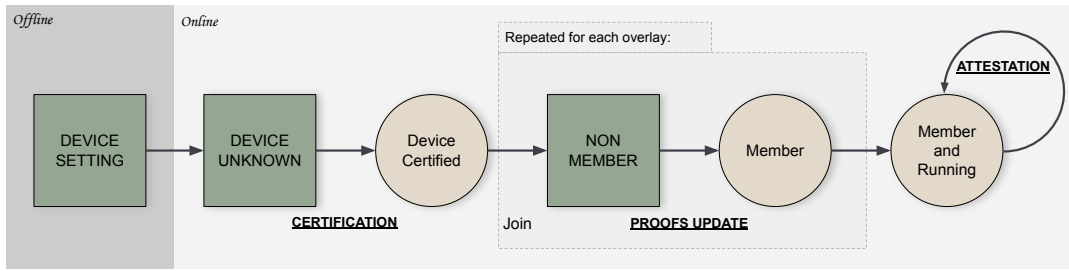

Figure 2: SAFE^d finite-state-machine. Addition of states and phases w.r.t. Chord are respectively shown with squares and bold underlined text.

- **Overlay ID (OID)**: identifies a device inside an *overlay*. Therefore, a device has a different OID for each *overlay*.
- **Unique ID (UID)**: identifies a *proof* of a device. It is the same for all the *overlays*.

Our design allows to randomly allocate the devices in each *overlay*, and therefore, an adversary cannot predict the *proofs* location.

We can explain the usage of these IDs by means of an example. Assume SAFE^d has two *overlays*. We assign three IDs to a device D , namely D_{OID_1} , D_{OID_2} , and D_{UID} . The first two (*i.e.*, D_{OID_1} and D_{OID_2}) identify the position of D inside the two *overlays* respectively. The last one (*i.e.*, D_{UID}) identifies the position of its *proof* in each *overlay*. The OIDs are computed online when the device enters the network. In Section 5.5, we describe the OID creation process that makes them random and applicable as public keys in a secure communication protocol. The UID, instead, is computed offline and is used as the key for retrieving the *proof* from the various *overlays* during an attestation process. We indicate UID and *proof* as a key/value pair (UID, *proof*). As a result, even if the UID is predictable, an external attacker cannot foresee which device contains the *proof* linked with it.

5.1 Protocol Overview

In SAFE^d, we strengthen the Chord protocol to achieve the following properties. First, we desire that only authorized devices join the network. Second, we need to spread multiple copies of the *proofs* among the *overlays*. The entire protocol is represented as a finite-state-machine in Figure 2, where the shapes (*i.e.*, circle and squares) represent a device status, while the arrows represent the transaction from a status to the next one. More precisely, the new status introduced by SAFE^d are depicted as squares, while the new phases are labeled with bold underlined text. In the following subsections, we describe the additions in detail:

- **Device-setting** defines the initial device configuration.
- **Device-unknown** and **Certification** allow only recognized devices to join the network (Section 5.2).
- **Non-member** and **Proofs update** are used to enhance availability of data in our dynamic context (Section 5.3).
- **Attestation** is used to monitor the integrity of other devices inside the network (Section 5.4).

As a whole, the protocol of SAFE^d is composed by two distinct phases: *Offline* and *Online*.

During the *Offline* phase, we boot the devices and set the following parameters inside the trusted anchor:

- The pair (UID, *proof*), which will be saved inside the network and later used for attestation/verification.
- A public/private key pair which are signed by a certification authority (CA).
- The CA certificate for the key pair.

During the *Online* phase, a device in *Device-unknown* status connects to the network and starts the procedure to access SAFE^d-*net*. We introduced this phase because Chord does not handle authentication by default. After the *Certification* is done, a device enters the *Device-certified* status and it can *join* each *overlay* asynchronously. A device that does not pass the *Certification* cannot physically communicate with other devices because it does not receive any OIDs from the entry point. The following procedure is repeated for every *overlay*. During the *join* phase, a device finds its successor around the ring by following standard Chord algorithms. It then sends its pair (UID, *proof*) to be stored. After this task is completed, the device assumes a *Non-member* status, which means that: (i) the device is aware of its position around the ring, (ii) it has inserted its own *proof* inside the *overlay* and (iii) it has not received yet the *proofs* it has to store. At this point, the device performs its first stabilize operation, making its successor aware of its presence inside the *overlay*. This triggers the *Proofs update*, which consists in the successor sending a copy of the *proofs* that should be stored inside the new device. A node maintains *Non-member* status until it is completely integrated inside the ring, *i.e.*, the preceding and following devices becomes aware of it. When this is the case, it has become officially part of the *overlay* and it can switch to the *Member* status. This allows the device to perform the *Rectify* operation as described in the original Chord protocol and permits to the successor to safely delete the *proofs* previously copied. It is fundamental to maintain different *Member* status for each *overlay* because the *Attestation* process involves all the *overlays*. Therefore, we require a device to become *Member* in all of them before being able to execute it, thus reaching *Member-and-Running* status.

5.2 Certification Phase

We desire that only authorized devices join SAFE^d-*net* network because this ensures an honest execution of the SAFE^d-*net* procedures (*i.e.*, due to trusted anchor isolation). More precisely, an entry point N can recognize the identity of a device U , which is in

Device-unknown status, by using a public key infrastructure (PKI), as described in Figure 3. All the devices are initialized during the *Offline phase* and receive a private key (e.g., N_{PRV}) and the corresponding certificate (e.g., N_{CERT}), signed by a certification authority (CA). The procedure uses a generic asymmetric encryption schema denoted as E .

The protocol starts with U that generates a nonce r and sends it along with its certificate (i.e., $U_{CERT}||r$) to N . After N correctly verifies the signature of U_{CERT} , it encrypts all of its OIDs and the nonce r (i.e., $[N_{OID}||r]$) by first using the public key of U (i.e., U_{PUB}) and then its private key (i.e., N_{PRV}). Finally, N sends them back to U along with its certificate (i.e., N_{CERT}). At this point, U performs the following operations: (i) verifies the certificate of N (i.e., N_{CERT}) using the CA public key, (ii) verifies the public key of N using the certificate and removes first encryption with it, (iii) extracts the OIDs of N (i.e., $[N_{OID}]$) and nonce (i.e., r') using its own private key, (iv) checks the nonce r and r' to avoid replay attacks, (v) generates its own OIDs (i.e., $[U_{OID}]$), and (vi) sets its status to *Device-certified*. The double encryption guarantees two properties: (i) the public key of U ensures that only U can decrypt the message and, (ii) the private key of N ensures that the message has been sent by N .

From this point ahead, U can communicate with the entry point by using the encryption schema described in Section 5.5. More precisely, U joins the *overlays* as described in Chord. A device that does not pass the *Certification* phase cannot receive the OIDs of the entry point and, therefore, cannot communicate with the other devices. To protect from the leakage of the private key during physical attacks, it is fundamental to implement a certificate revocation procedure. We discuss possible solutions in Section 8.

5.3 Multiple Device Entrance

SAFE^d maintains all the *proofs* available and consistent in all the *overlays* in case of groups of devices that attempt joining the network simultaneously. To achieve this, we introduce the *Non-member* status and the *Proof update* task.

Figure 4 shows the main four steps of *Proof update*, that begins when a new device C enters in an *overlay*. The rectangle before the node letter is a representation of the *proofs* stored inside of it. In step 1, we assume having two devices A and B correctly distributed around the *overlay* (i.e., $A_{OID} < B_{OID}$). In step 2, C

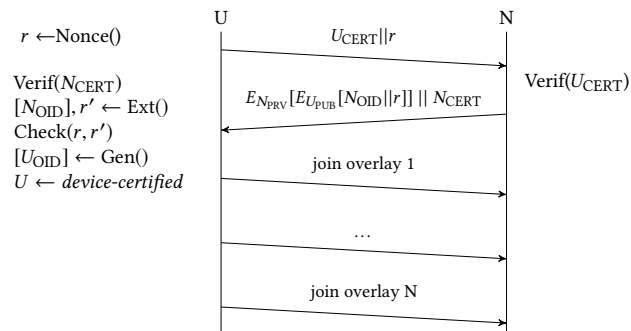

Figure 3: Certification phase between an unknown device U and the entry point N .

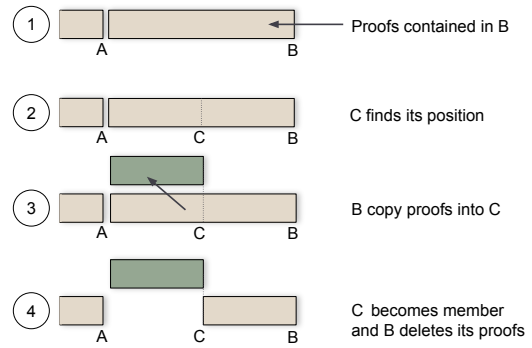

Figure 4: Main steps of a new device that enters the *overlay*. The device remains *Non-member* until its neighbours in the *overlay* become aware of it, i.e., it becomes *Member* of the *overlay*.

has just *joined* and it has found its position between A and B (i.e., $A_{OID} < C_{OID} < B_{OID}$). In this step, C is in *Non-member* status and it can only perform *stabilize*. This allows us to handle the entrance of multiple devices simultaneously and will be described later. In step 3, B copies into C the relative *proofs* while keeping a temporary copy in B itself. Keeping a copy of the *proofs* into B enables the other devices to find the C *proofs* even though C has not entered the ring yet. In step 4, A performs *rectify* and inserts C as its successor. C is formally part of the *overlay* and consequently can shift to *Member* status, while B can delete its leftover *proofs*. After step 4, C starts performing *rectify*. When C becomes *Member* in all the *overlays*, it reaches *Member-and-running* status and starts performing/receiving attestations.

This approach allows us to handle group of devices that enter simultaneously. For instance, a new device D may attempt entering while C is still a *Non-member*. Here, we distinguish two cases: (i) D is located between A and C (i.e., $A_{OID} < D_{OID} < C_{OID}$) and sets C as successor; (ii) D is located between C and B (i.e., $C_{OID} < D_{OID} < B_{OID}$) and sets B as successor. In both cases, D is kept as *Non-member* until its successor becomes *Member* as well. The difference is just in the order in which the devices become *Member*. In case (i), D receives *Member* status from C , therefore, the entrance order is C , then D . In case (ii), D receives *Member* status from B , while C changes its successor to D after doing a *stabilize* to B . Generally, *Member* status is assigned only by other *Member* (or *Member-and-running*) devices, which are considered stable. We keep *rectify* disabled while a device is *Non-member* to avoid the formation of *chains* of devices that would cause some of them to have outdated list of *proofs*.

5.4 Attestation Protocol

SAFE^d attestation process is an extension of classic RA (Section 3.1). The main differences are essentially two: (i) all the devices can assume the role of either *Prover* or *Verifier*, and (ii) the *proofs* are spread among all devices. The entire attestation process is implemented in a dedicated phase, which is executed whenever a device

inside the network needs to verify the integrity of another device before starting a communication.

The attestation is composed by the following steps:

- **Verifier initialization:** when the attestation is triggered, the device enters in *Verifier* mode.
- **Attestation request:** the *Verifier* challenges the *Prover*.
- **Retrieve report:** the *Prover* measures itself and returns a report defined as (UID, HASH) to the *Verifier*. The UID is used to retrieve the *proofs* from the *overlays*, while the HASH is the current self-measure of the *Prover*, which can be corrupted.
- **Retrieve proofs:** the *Verifier* queries all the *overlays* to retrieve the *proofs* using the received UID. The *proofs* will be used to check the report validity.
- **Voting:** we use a First Past The Post (FTPT) voting schema [3] to decide the healthy status of the *Prover*. In case of compromised status, the *Verifier* reacts in a proper way (see Attack Reaction below).
- **Recovery:** in case of missing *proofs*, the *Verifier* uses the retrieved data to recover the information where it has been lost. In case no *overlay* returned the *proof*, the *Verifier* launches a warning of possible infection for that particular device. Finally, the device exits from the *Verifier* mode.

Voting. FTPT is a plurality voting system that elects the most voted choice as the winner. During the voting phase, the *Verifier* considers the *proofs* collected from the various *overlays* as a preference vote, *i.e.*, which state each overlay thinks is the correct one. At first, the *Verifier* evaluates all the missing *proofs* as blank votes and it does not consider them in the counting. Then, the *Verifier* chooses the correct *proof* by picking the one that was returned the highest number of times. The elected *proof* is then used to verify the *report* sent by the *Prover*. The devices whose vote disagreed with the elected *proof* are considered infected as well.

Despite its simplicity, FTPT shows in our case resilience against manipulation. An attacker cannot foresee the location of the *proofs* in the network. As a result, the voting is robust till at least 50% devices are healthy. Due to the design of SAFE^d, we can easily implement new type of voting schema [28].

Attack Reaction. The actual attack reaction strategy strictly depends by the network pursue. In our prototype, we isolate the corrupted devices. In other scenarios, for instance, we can implement an hard-reset of the device. This can be useful for malware such as Mirai [7]. It is also possible to save the attestation results in the *overlays* for future manual inspections.

5.5 Secure Device Communication

SAFE^d allows two devices to issue a secure communication channel by introducing a novel protocol that allows to share a symmetric key K with zero-message exchanged. Our approach overcomes the scalability limitations of previous ones [19, 22] that either requires a device to store every key needed for the communication or to execute a key exchange protocol to establish a secure channel. The protocol is based on Diffie Hellman [35] and exploits Chord properties. The main idea is that each OID represents the public key of a device that joined an *overlay*. In Section 5.2, we discuss our mechanism to allow only authorized devices to enter the network.

In our protocol, we assume that all the devices share two secure prime number g and N . During the join phase, a device randomly computes an OID as follows:

$$X = \text{rand}() \pmod{N},$$

$$\text{OID} = (g^X) \pmod{N}.$$

At first, a device randomly computes a number X (modulo N), which is kept secret within the trusted anchor. Then, it generates the OID by computing the exponentiation of X over g (modulo N). These two operations are repeated for each *overlay*. For the sake of simplicity, we continue the description considering a single *overlay*, however, it is possible to easily extend the approach to any number of *overlays*. We indicate the pair X , OID for a device D as follows:

$$(D_X, D_{\text{OID}}).$$

Two devices, namely A and B , that know the respective OIDs can compute a shared symmetric key K_{AB} as follows:

$$K_{AB} = (A_{\text{OID}})^{B_X} = (g^{A_X})^{B_X}$$

$$K_{AB} = (g^{B_X})^{A_X} = (B_{\text{OID}})^{A_X} \pmod{N}.$$

The key K_{AB} can now be used in a symmetric encryption schema E .

The design of Chord assures that each device knows the OIDs of its successors (*e.g.*, finger list and successor list). Therefore, if B is a device following A , B cannot compute K_{AB} because it does not have knowledge of A_{OID} . To overcome this problem, we need to send A_{OID} to B avoiding unauthorized entities to read the OID. We achieve this by encrypting A_{OID} such that only authorized devices can read it. The whole message structure is shown in the following:

$$E_{B_{\text{OID}}}[S_{\text{OID}}||A_{\text{OID}}] || E_{K_{AB}}[M] || O,$$

which comprises three parts:

- $E_{B_{\text{OID}}}[S_{\text{OID}}||A_{\text{OID}}]$ is the header and is encrypted by using a symmetric encryption schema E and B_{OID} as a key². This allows only the devices that are already participating the *overlay* (*i.e.*, B) to read the content. The header contains two OIDs, called *source* and *sender*. The first identifies the device which originally sent the message (*i.e.*, S_{OID}), while the second identifies the device which is currently forwarding the message to B (*i.e.*, A_{OID}). Keeping the *source* OID permits a fast reply; this will be described later through an example.
- $E_{K_{AB}}[M]$ is the message body. It contains the message M to deliver and is encrypted with the symmetric schema E and K_{AB} as a key.
- O indicates the *overlay* to which the message is meant to and is sent as plain text.

This structure enables B to decrypt an incoming message as follow:

- reads O and identify from which *overlay* is coming.
- uses its corresponding OID (*i.e.*, B_{OID}) to decrypt the header and to retrieve the sender OID (*e.g.*, A_{OID}).
- computes K_{AB} and decrypts M .

²Since the key space of E is generally smaller than the size of B_{OID} , we use a hash function H to adjust the size, *i.e.*, $E_{H(B_{\text{OID}})}[.]$

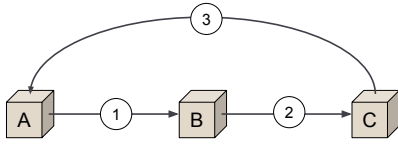

Figure 5: SAFE^d point-to-point communication protocol.

A packet structured in such way has three interesting properties: (i) besides the overlay O , no information is shipped as a plain text, thus only devices inside SAFE^d -net (also called *Member*) can read the headers (see Section 5.2); (ii) only the intended recipient can successfully decrypt the message, thus any attempt to manipulate or reroute the message will generate an error; (iii) a symmetric schema is less expensive than an asymmetric one, thus more suitable for low-power devices.

Figure 5 shows a complete example of two devices that communicate. In this case, a device A wants to send a message M to device C , but C is not directly reachable by A . Therefore, A must pass through the ring. At the beginning, A only knows the OID of B , because it is its successor. Therefore, A asks B to deliver M to C by creating packet (1) as follows:

$$E_{B_{\text{OID}}}[A_{\text{OID}}||A_{\text{OID}}] || E_{K_{AB}}[M] || O.$$

In this packet, *source* and *sender* OID coincide with A_{OID} . B decrypts the header with its OID, calculates K_{AB} using the *sender* OID and obtains the message M . Since B knows C , B relays the message crafted as follows:

$$E_{C_{\text{OID}}}[A_{\text{OID}}||B_{\text{OID}}] || E_{K_{BC}}[M] || O.$$

C follows similar steps to retrieve message M and serves the request. At this point, C replies to A by using the *source* OID (i.e., A_{OID}) and crafting message (3) as follows:

$$E_{A_{\text{OID}}}[A_{\text{OID}}||C_{\text{OID}}] || E_{K_{CA}}[M] || O.$$

Finally, A receives the response from C .

This approach brings three advantages: (i) we avoid spoofing attacks because the sender is automatically verified (unless the attacker steals its secret X), (ii) we can build a symmetric key without using extra messages, and (iii) a compromised device cannot choose its OIDs arbitrarily unless it resolves the discrete logarithm problem. We also mitigate reply attacks by using nonces [47].

6 IMPLEMENTATION

Figure 6 shows the architecture adopted for the platform Raspberry Pi 3. We developed our prototype on top of OP-TEE [26]³ and wrote it using C language. Since we designed SAFE^d to exploit ARM TrustZone features (Section 3.2), we split SAFE^d into two components: *untrusted* and *trusted application*. The *untrusted application* interacts with the peripherals, while the *trusted application* contains SAFE^d code and the private information. The network communication is implemented through a TCP client and server

³We used the commit f5172a4aa993f644d0edb3a64a49938fd2e6f906 and 28eea17f4dba5bbf7848926eb031ba660e8856f0 of the official repository for the OP-TEE OS and client respectively.

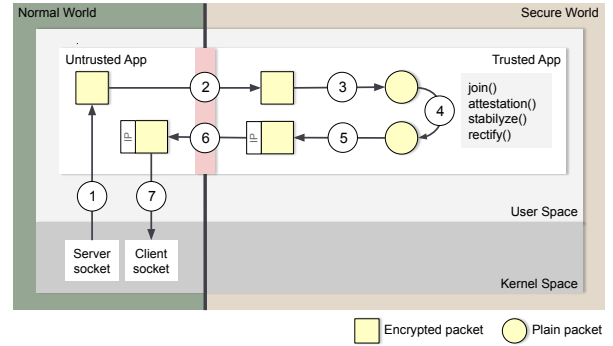

Figure 6: Execution pipeline.

socket in the *normal world*⁴. SAFE^d workflow is composed by a number of independent steps, which are depicted in Figure 6. In the beginning, SAFE^d waits for an incoming packet from the server socket (step 1). Once a packet arrives, it is sent into the *trusted application* (step 2). At this point, the packet is decrypted (step 3) and processed (step 4). After the response is created, it is encrypted (step 5) and written into the *untrusted application* along with the destination IP (step 6), which must be in plain text for correct routing. Finally, the packet is shipped by the client socket (step 7). The packets are built in such a way that the *untrusted application* knows only the destination IP, while the content is always encrypted as described in Section 5.5.

An attacker that alters the plain-text IP would simply lead to a trashed or lost message because the only device capable of decrypting it is the intended recipient (see Section 5.5). Moreover, blocking the message would cause the original sender to raise a warning for a timeout in its communications, thus exposing the attack.

Our prototype requires around 46KLoC for the untrusted application and around 49KLoC for the trusted application. We used AES-CBC [39] for symmetric encryption with keys 32B long, while we used RSA [10] for the asymmetric keys in the *certification phase*, with 1218B for the private key and 294B for the public one.

Measurement Generation. In our proof-of-concept, SAFE^d protects the integrity of critical pieces of software inside the *normal world* by using a shared memory. However, it is possible to extend SAFE^d to measure other device properties, such as hardware configuration. The location to protect is identified at the boot phase. For the sake of simplicity, our proof-of-concept can monitor memory regions that reside in the same process of SAFE^d . It is still possible to extend SAFE^d to read arbitrary physical addresses and protect the integrity of different parts of the system [42].

Omnet++ simulation. We performed a large scale performance analysis using Omnet++ [27, 41] as support. We implemented our protocol at the application level and used time delays to simulate cryptographic operations and propagation time. Based on the

⁴We could have implemented a socket in the secure world as well, however, not all trusted anchor platforms support this feature so we opted for a more flexible solution.

Raspberry Pi’s measurements, we set a delay of 10 ms for the decryption/encryption of the messages. Moreover, we set the communication rate at 250 Kbps based on the defined data-rate of ZigBee, a widely used communication protocol for networks of IoT devices.

7 EVALUATION

In this section, we evaluate different metrics of SAFE^d by using two network settings:

- **Raspberry Pi:** we mounted a small network of Raspberry Pi 3 composed by 4 devices. This setting was used to test the efficacy of SAFE^d on real devices and to collect realistic parameters for the simulation.
- **Omnet++:** we used Omnet++ to simulate a network of IoT devices that contained up to 10K entities and with different number of overlays (from 1 to 3). We used this setting to evaluate the performances of SAFE^d in the presence of thousands of devices and with a different number of *overlays*.

7.1 Network Analysis

We measure the size of the message used by SAFE^d, the elaboration time, and the time elapsed to perform a complete attestation.

Messages Size. SAFE^d requires two types of message:

- **Certification messages:** they are used only during the certification phase (Section 5.2) and require $256 \times o$ bytes, where o is the number of *overlays* (e.g., 1KB for 4 *overlays*). These messages are more expensive in terms of size but they are only used in the initial part.
- **Routine messages:** the other messages exchanged in our prototype have a fixed size of 384 bytes plus $68 \times s$ bytes, where s is the successor list size (e.g., 520B with 2 successors). They compose the vast majority of the network communication. Furthermore, s is a fixed parameter of the network, thus the message size remains constant throughout the execution.

Message Time Elapsed. We measure the time required to process a single message in a Raspberry Pi. We did not consider the *Certification* messages phase because they are used only during the initial part of the protocol. As a result, any message required on average 9.1ms (with a standard deviation of 6.3) to be processed without using cryptography, while around the double, 18ms (with a standard deviation of 9.2), using the cryptography described in Section 5.5. As already observed in [19, 22], cryptography is the predominant part during the protocol execution.

Attestation Performances. Figure 7a shows the average time elapsed to perform a complete attestation (y-axis) over the number of devices present inside the network (x-axis). A complete attestation involves sending the challenge, collecting the report and querying all the *overlays* to retrieve the *proofs*. The graph shows a logarithmic growth with the number of devices, while the number of *overlay* does not affect the overall performances because the packets are processed by each device independently. Considering 10K devices and 3 *overlays*, an entire attestation process requires around one second to be completed.

7.2 Memory Footprint

Each device uses 64, 1218, 294 and 256 bytes respectively for the UID, the private RSA key, the public RSA key and the certificate. For each *overlay*, it uses 32 bytes for the secret, 68 bytes for its own OID and its predecessor OID, 68 bytes for each entry in the successor list, 68 bytes for the entries in the finger list and 128 bytes for each element inside the proof storage. The overall memory usage M , expressed in bytes, can be computed as follows:

$$M = 1832 + [168 + 68 \times s + 68 \times f + 128 \times p] \times o,$$

where s is the size of the successor list, f is the size of the finger table, p is the number of *proofs* and o the number of *overlays*. Variables s and o are parameters that remain constant during the protocol execution. In the following paragraphs, we show that the finger list size f has an upper bound of $\log(n)$, with n the total number of devices inside the network, while the number of *proofs* p is small *w.r.t.* the network size.

Finger Table Size. Figure 7b shows the maximum number of entries in a finger table (y-axis) against the number of device in the network (x-axis). The graph shows a logarithmic growth with the number of devices and a linear pattern with the number of *overlays*. This is due to the design of the finger table and of SAFE^d. This table, in fact, is used by Chord to optimize packets routing (see Section 3.3) and contains at most a logarithmic number of entries with respect to the network size. Moreover, each node maintains a separate table for every *overlay*. The overall memory cost is then logarithmic in the number of devices and linear in the number of *overlays*.

Proofs Distribution. Figure 7d shows an empirical analysis of the *proofs* distribution in a simulated network with 10K devices and using different *overlays* (from 1 to 3). On average, each device should contain a number of *proofs* equal to the number of *overlays*. However, since the distribution is random, some device may contain more *proofs* than others. The number of *overlays* helps improve the *proofs* distribution. In fact, with 3 *overlays* the curve tends to be smoother. In the worst scenario, we measured only less than 5 devices that contained 25 *proofs* in a network with 10K elements and 3 *overlays*. In case of 3 *overlays*, a network contains 30K *proofs*, 3 for each device. Our approach allows to build a collaborative attestation by solely requiring a device to contain 25 *proofs* at most, which makes SAFE^d scalable.

To sum up, the number of *proofs* p that a device stores is bounded and can be forced to reach the ideal value (i.e., 1 *proofs* for each *overlay*). Considering the overall memory consumption, SAFE^d is a clear improvement with respect to previous works that are either an order of magnitude more expensive [22] or have a quadratic dependence on unpredictable parameters [19].

7.3 Resilience

The purpose of this experiment is to measure the ability of SAFE^d to recover missing *proofs* in case of attacks or faults. In this scenario, we modeled a powerful attacker that randomly destroys all the *proofs* of a device. In a real case, this simulates an adversary that physically destroys a device, interrupts the *normal world* scheduling, or simply a fault in the network. This attack is tuned by a drop rate

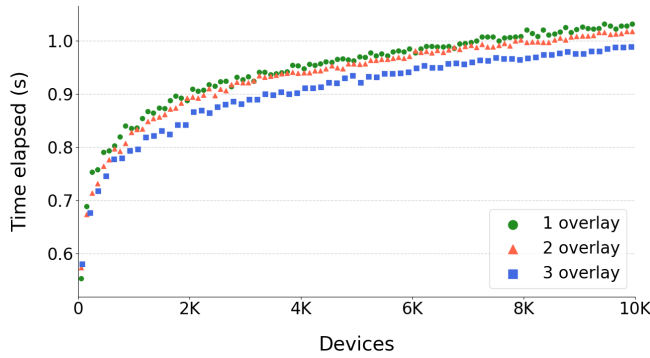

(a) Time elapsed for performing a complete attestation.

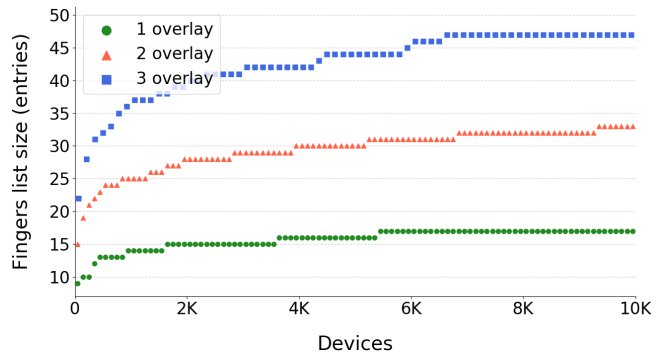

(b) Maximum finger table size, considering all the overlays.

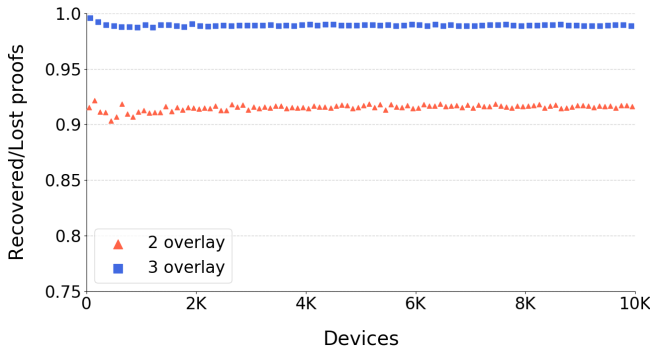

(c) Resilience to lost proofs, measured as the recovered proofs over the lost ones with a drop-rate of 20%.

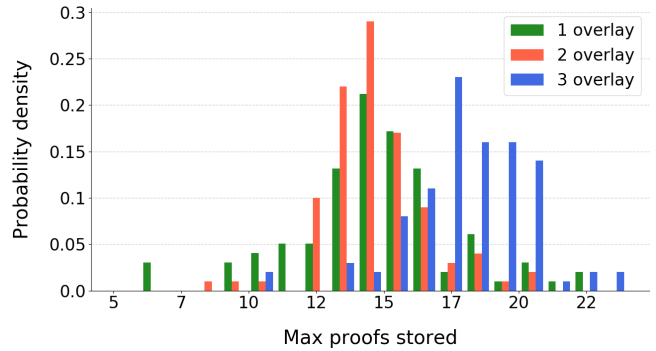

(d) Probability density of the maximum number of proofs stored by a single device in a network of 10K devices.

Figure 7: Network overhead, finger table size, resilience measurements and maximum *proofs* overhead of SAFE^d prototype.

which indicates the number of devices that drops all their *proofs* on every simulation cycle. We experimented a drop rate of 20% with a simulation cycle of 10 seconds, which means that on average 20% of the entire network erased all of its proofs every 10 seconds. We tested a different number of *overlays* to observe the different responses. Figure 7c shows the results of our experiments in a simulated network that contains up to 10K devices and different number of *overlay* (from 1 to 3). The y-axis shows the *resilience index*, which is the ratio between the number of *proofs* correctly recovered and the number of lost *proofs*. The x-axis, instead, shows the number of devices in the network. According to the attestation algorithm (Section 5.4), in case of lost *proofs*, the *Verifier* attempts to recover the missing information from the other *overlays*. Therefore, the *resilience index* tends to 1 if all the *proofs* were correctly recovered, otherwise it goes to 0. The plot shows that with the increases of the *overlays*, the *resilience index* tends to reach 1 even in the presence of an high drop rate. More precisely, we manage to recover 99.9% of the *proofs* with 3 *overlays*. This experiment shows that the *overlays* can be effectively used to recover the network in the presence of attacks.

7.4 Security Consideration

We describe how SAFE^d reacts against different attacker scenarios.

Tampered Devices. An attacker may infect a device and take control of it. Since we use a trusted anchor, we consider the *secure world* as protected, while the *normal world* can be under attacker control. Therefore, SAFE^d protocol is protected by design. Moreover, all the packets that transit through the *normal world* are encrypted, thus outside the attacker range. However, an attacker may avoid invoking trusted anchor code compromising *normal world* scheduler. In this case, if the *trusted world* is not triggered, the Chord protocol cannot work properly, and the neighbour devices can realize the attack.

To test SAFE^d effectiveness, we verified that the other devices are able to spot the modified code inside the *normal world*.

Attacks against the Network. All the messages exchanged among trusted anchors are encrypted (Section 5.5) and only devices that joined the network can communicate among each other (Section 5.2). Man-in-the-middle [9] attacks are mitigated by design: (i) the body is protected by the symmetric key K_{AB} , (ii) the header can be manipulated only by the trusted anchors of authorized devices. We also include *nonces* to avoid replay attacks. This enhances

robustness even in case of corrupted devices as long as their trusted anchor remains intact.

Physical attacks. According to DARPA attacker model [20], a device which receives a physical attack is temporarily removed from the network. Previous authors [20–22] proposed to use a heartbeat to keep the devices synchronized. In this way, a device that goes temporarily off-line cannot get aligned with the heartbeat, and therefore, enables the detection of the attack. However, establishing a heartbeat protocol implies the presence of loosely synchronized and secure clocks in every device. SAFE^d overcomes this requirement by using the communication timeouts and *nonces* to detect network disconnections. During the protocol execution, each device periodically contacts its successor to assess its status. In case a timeout occurs, the device uses the successor list to contact the closest node following the old one. The contacted device will further check if its predecessor left the network, and if so, it will acquire the message sender as new predecessor, while launching an alert for a possible physical attack. The double check adds robustness against simple network malfunctions. To enhance the protection against physical attacks, we further propose a certificate revocation strategy that will be discussed in Section 8.

Denial-of-Service. We do not protect against denial-of-service in case of a network entirely compromised (e.g., all the messages are dropped). However, we can partially recover information loss by combining multiple *overlays* and our attestation protocol (Section 7.3).

8 DISCUSSION

Certificate Revocation. SAFE^d security properties can be further improved by adopting an efficient certificate revocation mechanism. This feature can be useful in at least three scenarios: (i) if the CA private key gets compromised (e.g., leaked), (ii) if a software is updated and (iii) if a device is corrupted. The design of a scalable and efficient certificate revocation procedure was already addressed by [18, 30] that proposed solutions based on Bloom filters [11]. Furthermore, [5] proposed a way to make a Bloom filter scalable, i.e., to make its capacity adaptable at runtime so that it can be increased without stopping the general execution. It is possible to implement in SAFE^d a certificate revocation protocol that is scalable and distributed based on the previous citations.

Run-time Attacks. An attacker could alter the application behavior without modifying the binary by using run-time attacks [12]. A way to cope with those threats is using run-time remote attestation [1, 40] that can verify run-time properties, e.g., the current execution path. Usually, these solutions require several *proofs* to be stored. We can use the DHTs in SAFE^d to spread the *proof* load among devices. We leave this as a future work.

Run-time Software Upgrade. In specific cases (e.g., industrial IoT), we need to upgrade devices software without interrupting the network. In SAFE^d, we do not deal with this case, but it is possible to mitigate this issue by using two main approaches: (i) we could introduce new upgraded devices in the network and remove the old ones until all the network is upgraded, (ii) we integrate specific upgrade protocols in SAFE^d that load new software and

substitute the *proofs* in the DHTs. Regardless the strategy adopted, the software upgrade strategy should be integrated with a strong certificate revocation mechanisms to avoid an attacker to re-upload old and vulnerable software.

9 CONCLUSION

In this work, we proposed SAFE^d, the first concrete self-attestation schema for networks of heterogeneous embedded devices. SAFE^d maintains multiple copies of the *proofs* among the devices, which are equipped with small trusted anchors. We also designed and developed new techniques that enhance classic DHT protocols against powerful adversaries, which are typical of remote attestation scenarios.

SAFE^d allows performing remote attestations without the need of an external *Verifier*, and consequently removing a single point of failure. SAFE^d coordinates multiple devices to self-protect the network and also to self-recover missing or corrupted *proofs* in presence of attackers and faults.

We implemented a prototype of SAFE^d in the open-source platform Raspberry Pi 3, this allows us to show the technical challenges faced for the implementation of SAFE^d in the ARM TrustZone architecture. Moreover, we stressed SAFE^d performances by simulating a network of 10K devices. As a result, we showed that SAFE^d requires a logarithmic amount of memory and a logarithmic time to perform a complete attestation. Moreover, SAFE^d can recover up to 99.9% of *proofs* in case of attack or faults by using only three *overlays*.

REFERENCES

- [1] T. Abera, N. Asokan, L. Davi, J.-E. Ekberg, T. Nyman, A. Paverd, A.-R. Sadeghi, and G. Tsudik, "C-flat: Control-flow attestation for embedded systems software," in *Proceedings of the 2016 ACM SIGSAC Conference on Computer and Communications Security*, ser. CCS '16. New York, NY, USA: ACM, 2016, pp. 743–754. [Online]. Available: <http://doi.acm.org/10.1145/2976749.2978358>
- [2] T. Abera, R. Bahmani, F. Brasser, A. Ibrahim, A. Sadeghi, and M. Schunter, "Diat: Data integrity attestation for resilient collaboration of autonomous systems," in *26th Annual Network & Distributed System Security Symposium (NDSS)*. The Internet Society, January 2019. [Online]. Available: <http://tubiblio.ulb.tu-darmstadt.de/110632/>
- [3] G. Adams and W. Keech, "First past the post, in politics," in *International Encyclopedia of the Social and Behavioral Sciences*, N. J. Smelser and P. B. Baltes, Eds. Oxford: Pergamon, 2001, pp. 5686 – 5688. [Online]. Available: <http://www.sciencedirect.com/science/article/pii/B0080430767011402>
- [4] D. Ahmat, M. Choroma, and T. F. Bissyandé, "Multipath key exchange scheme based on the diffie-hellman protocol and the shamir threshold," *IJ Network Security*, vol. 21, no. 3, pp. 418–427, 2019. [Online]. Available: <http://ijns.jalaxy.com.tw/contents/ijns-v21-n3/ijns-2019-v21-n3-p418-427.pdf>
- [5] P. S. Almeida, C. Baquero, N. Preguiça, and D. Hutchison, "Scalable bloom filters," *Information Processing Letters*, vol. 101, no. 6, pp. 255 – 261, 2007. [Online]. Available: <http://www.sciencedirect.com/science/article/pii/S0020019006003127>
- [6] M. Ambrosin, M. Conti, A. Ibrahim, G. Neven, A.-R. Sadeghi, and M. Schunter, "Sana: Secure and scalable aggregate network attestation," in *Proceedings of the 2016 ACM SIGSAC Conference on Computer and Communications Security*, ser. CCS '16. New York, NY, USA: ACM, 2016, pp. 731–742. [Online]. Available: <http://doi.acm.org/10.1145/2976749.2978335>
- [7] M. Antonakakis, T. April, M. Bailey, M. Bernhard, E. Bursztein, J. Cochran, Z. Durumeric, J. A. Halderman, L. Invernizzi, M. Kallitsis, D. Kumar, C. Lever, Z. Ma, J. Mason, D. Menscher, C. Seaman, N. Sullivan, K. Thomas, and Y. Zhou, "Understanding the mirai botnet," in *Proceedings of the 26th USENIX Conference on Security Symposium*, ser. SEC'17. Berkeley, CA, USA: USENIX Association, 2017, pp. 1093–1110. [Online]. Available: <http://dl.acm.org/citation.cfm?id=3241189.3241275>
- [8] N. Asokan, F. Brasser, A. Ibrahim, A.-R. Sadeghi, M. Schunter, G. Tsudik, and C. Wachsmann, "Seda: Scalable embedded device attestation," in *Proceedings of the 22nd ACM SIGSAC Conference on Computer and Communications Security*,

- ser. CCS '15. New York, NY, USA: ACM, 2015, pp. 964–975. [Online]. Available: <http://doi.acm.org/10.1145/2810103.2813670>
- [9] N. Asokan, V. Niemi, and K. Nyberg, "Man-in-the-middle in tunnelled authentication protocols," in *Proceedings of the 11th International Conference on Security Protocols*. Berlin, Heidelberg: Springer-Verlag, 2005, pp. 28–41. [Online]. Available: http://dx.doi.org/10.1007/11542322_6
 - [10] P. Barrett, "Implementing the rivest shamir and adleman public key encryption algorithm on a standard digital signal processor," in *Proceedings on Advances in cryptography—CRYPTO '86*. London, UK: Springer-Verlag, 1987, pp. 311–323. [Online]. Available: <http://dl.acm.org/citation.cfm?id=36664.36688>
 - [11] A. Broder and M. Mitzenmacher, "Network applications of bloom filters: A survey," *Internet Mathematics*, vol. 1, no. 4, pp. 485–509, 2004. [Online]. Available: <https://doi.org/10.1080/15427951.2004.10129096>
 - [12] N. Carlini and D. Wagner, "ROP is still dangerous: Breaking modern defenses," in *23rd USENIX Security Symposium (USENIX Security 14)*. San Diego, CA: USENIX Association, Aug. 2014, pp. 385–399. [Online]. Available: <https://www.usenix.org/conference/usenixsecurity14/technical-sessions/presentation/carlini>
 - [13] X. Carpent, K. ElDefrawy, N. Rattanavipanon, and G. Tsudik, "Lightweight swarm attestation: A tale of two lisa-s," in *Proceedings of the 2017 ACM on Asia Conference on Computer and Communications Security*, ser. ASIA CCS '17. New York, NY, USA: ACM, 2017, pp. 86–100. [Online]. Available: <http://doi.acm.org/10.1145/3052973.3053010>
 - [14] D. Dolev and A. C. Yao, "On the security of public key protocols," in *Proceedings of the 22nd Annual Symposium on Foundations of Computer Science*, ser. SFCS '81. Washington, DC, USA: IEEE Computer Society, 1981, pp. 350–357. [Online]. Available: <https://doi.org/10.1109/SFCS.1981.32>
 - [15] K. ElDefrawy, N. Rattanavipanon, and G. Tsudik, "Hydra: Hybrid design for remote attestation (using a formally verified microkernel)," in *Proceedings of the 10th ACM Conference on Security and Privacy in Wireless and Mobile Networks*, ser. WiSec '17. New York, NY, USA: ACM, 2017, pp. 99–110. [Online]. Available: <http://doi.acm.org/10.1145/3098243.3098261>
 - [16] K. ElDefrawy and G. Tsudik, "Advancing remote attestation via computer-aided formal verification of designs and synthesis of executables: Opinion," in *Proceedings of the 12th Conference on Security and Privacy in Wireless and Mobile Networks*, ser. WiSec '19. New York, NY, USA: ACM, 2019, pp. 45–48. [Online]. Available: <http://doi.acm.org/10.1145/3317549.3323403>
 - [17] T. Fujii, Y. Ren, Y. Hori, and K. Sakurai, "Security analysis for p2p routing protocols," in *2009 International Conference on Availability, Reliability and Security*. IEEE, March 2009, pp. 899–904. [Online]. Available: <https://ieeexplore.ieee.org/document/5066584>
 - [18] J. J. Haas, Y.-C. Hu, and K. P. Laberteaux, "Efficient certificate revocation list organization and distribution," *IEEE J.Sel. A. Commun.*, vol. 29, no. 3, pp. 595–604, Mar. 2011. [Online]. Available: <https://doi.org/10.1109/JSAC.2011.110309>
 - [19] A. Ibrahim, A.-R. Sadeghi, and G. Tsudik, "Us-aid: Unattended scalable attestation of iot devices," in *37th IEEE International Symposium on Reliable Distributed Systems*, July 2018. [Online]. Available: <https://ieeexplore.ieee.org/document/8613950>
 - [20] A. Ibrahim, A.-R. Sadeghi, G. Tsudik, and S. Zeitouni, "Darpa: Device attestation resilient to physical attacks," in *Proceedings of the 9th ACM Conference on Security & Privacy in Wireless and Mobile Networks*, ser. WiSec '16. New York, NY, USA: ACM, 2016, pp. 171–182. [Online]. Available: <http://doi.acm.org/10.1145/2939918.2939938>
 - [21] F. Kohnhäuser, N. Büscher, S. Gabmeyer, and S. Katzenbeisser, "Scapi: A scalable attestation protocol to detect software and physical attacks," in *Proceedings of the 10th ACM Conference on Security and Privacy in Wireless and Mobile Networks*, ser. WiSec '17. New York, NY, USA: ACM, 2017, pp. 75–86. [Online]. Available: <http://doi.acm.org/10.1145/3098243.3098255>
 - [22] F. Kohnhäuser, N. Büscher, and S. Katzenbeisser, "A practical attestation protocol for autonomous embedded systems," in *4th IEEE European Symposium on Security and Privacy (EuroS&P'19)*, June 2019. [Online]. Available: <http://tubiblio.ulb.tu-darmstadt.de/114633/>
 - [23] G. Kunzmann and A. Binzenhofer, "Autonomically improving the security and robustness of structured p2p overlays," in *2006 International Conference on Systems and Networks Communications (ICSNC'06)*. IEEE, 2006, pp. 18–18. [Online]. Available: <https://ieeexplore.ieee.org/document/4041533>
 - [24] M. Kylänpää and A. Rantala, "Remote attestation for embedded systems," in *Security of Industrial Control Systems and Cyber Physical Systems*, A. Bécue, N. Cuppens-Boulahia, F. Cuppens, S. Katsikas, and C. Lambrinouidakis, Eds. Cham: Springer International Publishing, 2016, pp. 79–92.
 - [25] W. Li, H. Li, H. Chen, and Y. Xia, "Adattester: Secure online mobile advertisement attestation using trustzone," in *Proceedings of the 13th Annual International Conference on Mobile Systems, Applications, and Services*, ser. MobiSys '15. New York, NY, USA: ACM, 2015, pp. 75–88. [Online]. Available: <http://doi.acm.org/10.1145/2742647.2742676>
 - [26] Linaro. (2015) Op-tee. Last access June 2019. [Online]. Available: https://github.com/OP-TEE/optee_jos
 - [27] O. Ltd. Omnet++ discrete event simulator. Last access November 2019. [Online]. Available: <https://omnetpp.org>
 - [28] M. F. Madsen, M. Gaub, M. E. Kirkbro, and S. Debois, "Transforming byzantine faults using a trusted execution environment," in *2019 15th European Dependable Computing Conference (EDCC)*, Sep. 2019, pp. 63–70.
 - [29] C. W. O'donnell and V. Vaikuntanathan, "Information leak in the chord lookup protocol," in *Proceedings. Fourth International Conference on Peer-to-Peer Computing, 2004. Proceedings*. IEEE, 2004, pp. 28–35. [Online]. Available: <https://ieeexplore.ieee.org/document/1334928>
 - [30] G. Rigazzi, A. Tassi, R. J. Piechocki, T. Tryfonas, and A. Nix, "Optimized certificate revocation list distribution for secure v2x communications," in *2017 IEEE 86th Vehicular Technology Conference (VTC-Fall)*, Sep. 2017, pp. 1–7.
 - [31] A.-R. Sadeghi, C. Wachsmann, and M. Waidner, "Security and privacy challenges in industrial internet of things," in *2015 52nd ACM/EDAC/IEEE Design Automation Conference (DAC)*. IEEE, June 2015, pp. 1–6. [Online]. Available: <https://ieeexplore.ieee.org/document/7167238>
 - [32] E. Sit and R. Morris, "Security considerations for peer-to-peer distributed hash tables," in *Revised Papers from the First International Workshop on Peer-to-Peer Systems*, ser. IPTPS '01. London, UK, UK: Springer-Verlag, 2002, pp. 261–269. [Online]. Available: <http://dl.acm.org/citation.cfm?id=646334.687810>
 - [33] M. Soliman, T. Abiodun, T. Hamouda, J. Zhou, and C.-H. Lung, "Smart home: Integrating internet of things with web services and cloud computing," in *2013 IEEE 5th international conference on cloud computing technology and science*, vol. 2. IEEE, 2013, pp. 317–320. [Online]. Available: <https://ieeexplore.ieee.org/document/6735443>
 - [34] M. Srivatsa and L. Liu, "Vulnerabilities and security threats in structured overlay networks: A quantitative analysis," in *Proceedings of the 20th Annual Computer Security Applications Conference*, ser. ACSAC '04. Washington, DC, USA: IEEE Computer Society, 2004, pp. 252–261. [Online]. Available: <http://dx.doi.org/10.1109/CSAC.2004.50>
 - [35] M. Steiner, G. Tsudik, and M. Waidner, "Diffie-hellman key distribution extended to group communication," in *Proceedings of the 3rd ACM Conference on Computer and Communications Security*, ser. CCS '96. New York, NY, USA: ACM, 1996, pp. 31–37. [Online]. Available: <http://doi.acm.org/10.1145/238168.238182>
 - [36] I. Stoica, R. Morris, D. Karger, M. F. Kaashoek, and H. Balakrishnan, "Chord: A scalable peer-to-peer lookup service for internet applications," *SIGCOMM Comput. Commun. Rev.*, vol. 31, no. 4, pp. 149–160, Aug. 2001. [Online]. Available: <http://doi.acm.org/10.1145/964723.383071>
 - [37] I. Stoica, R. Morris, D. Liben-Nowell, D. R. Karger, M. F. Kaashoek, F. Dabek, and H. Balakrishnan, "Chord: A scalable peer-to-peer lookup protocol for internet applications," *IEEE/ACM Trans. Netw.*, vol. 11, no. 1, pp. 17–32, Feb. 2003. [Online]. Available: <http://dx.doi.org/10.1109/TNET.2002.808407>
 - [38] M. Suvanto, "Privacy in peer-to-peer networks," *Helsinki University of Technology T-11051 Seminar on Networking*, January 2005.
 - [39] J. Thakur and N. Kumar, "Des, aes and blowfish: Symmetric key cryptography algorithms simulation based performance analysis," *International journal of emerging technology and advanced engineering*, vol. 1, no. 2, pp. 6–12, 2011. [Online]. Available: <http://citeseerx.ist.psu.edu/viewdoc/summary?doi=10.1.1.366.831>
 - [40] F. Toffalini, E. Losiouk, A. Biondo, J. Zhou, and M. Conti, "Scarr: Scalable runtime remote attestation for complex systems," in *22nd International Symposium on Research in Attacks, Intrusions and Defenses (RAID 2019)*. Chaoyang District, Beijing: USENIX Association, Sep. 2019, pp. 121–134. [Online]. Available: <https://www.usenix.org/conference/raid2019/presentation/toffalini>
 - [41] A. Varga, "Omnet++," in *Modeling and tools for network simulation*. Springer, 2010, pp. 35–59.
 - [42] J. Williams, "Inspecting data from the safety of your trusted execution environment," *BlackHat USA*, 2015. [Online]. Available: <https://www.blackhat.com/docs/ldn-15/materials/london-15-Williams-Inspecting-Data-From-The-Safety-Of-Your-Trusted-Execution-Environment-wp.pdf>
 - [43] J. Winter, "Trusted computing building blocks for embedded linux-based arm trustzone platforms," in *Proceedings of the 3rd ACM Workshop on Scalable Trusted Computing*, ser. STC '08. New York, NY, USA: ACM, 2008, pp. 21–30. [Online]. Available: <http://doi.acm.org/10.1145/1456455.1456460>
 - [44] W. Yan, A. Fu, Y. Mu, X. Zhe, S. Yu, and B. Kuang, "Eapa: Efficient attestation resilient to physical attacks for iot devices," in *Proceedings of the 2Nd International ACM Workshop on Security and Privacy for the Internet-of-Things*, ser. IoT S&P'19. New York, NY, USA: ACM, 2019, pp. 2–7. [Online]. Available: <http://doi.acm.org/10.1145/3338507.3358614>
 - [45] P. Zave, "How to make chord correct (using a stable base)," *CoRR*, vol. abs/1502.06461, 2015. [Online]. Available: <http://arxiv.org/abs/1502.06461>
 - [46] H. Zhang, Y. Wen, H. Xie, and N. Yu, *Distributed hash table: Theory, platforms and applications*. Springer, 2013.
 - [47] J. Zhen and S. Srinivas, "Preventing replay attacks for secure routing in ad hoc networks," in *International Conference on Ad-Hoc Networks and Wireless*. Springer, 2003, pp. 140–150.