

# Recurrent Graph Syntax Encoder for Neural Machine Translation

Liang Ding    Dacheng Tao

UBTECH Sydney AI Centre, SCS, FEIT, University of Sydney

ldin3097@uni.sydney.edu.au, dacheng.tao@sydney.edu.au

## Abstract

Syntax-incorporated machine translation models have been proven successful in improving the model’s reasoning and meaning preservation ability. In this paper, we propose a simple yet effective graph-structured encoder, the Recurrent Graph Syntax Encoder, dubbed **RGSE**, which enhances the ability to capture useful syntactic information. The RGSE is done over a standard encoder (recurrent or self-attention encoder), regarding recurrent network units as graph nodes and injects syntactic dependencies as edges, such that RGSE models syntactic dependencies and sequential information (*i.e.*, word order) simultaneously. Our approach achieves considerable improvements over several syntax-aware NMT models in English⇒German and English⇒Czech translation tasks. And RGSE-equipped big model obtains competitive result compared with the state-of-the-art model in WMT14 En-De task. Extensive analysis further verifies that RGSE could benefit long sentence modeling, and produces better translations.

## 1 Introduction

Neural machine translation (NMT), proposed as a novel end-to-end paradigm (Kalchbrenner and Blunsom, 2013; Sutskever et al., 2014; Bahdanau et al., 2015; Gehring et al., 2017; Wu et al., 2016; Vaswani et al., 2017), has obtained competitive performance compared to statistical machine translation (SMT). Although the attentional encoder-decoder model can recognize most of the structure information, there is still a certain degree of syntactic information missing, potentially resulting in syntactic errors (Shi et al., 2016; Linzen et al., 2016; Raganato and Tiedemann, 2018). Researches on leveraging explicit linguistic information have been proven helpful in obtaining better sentence modeling results (Kuncoro et al., 2018;

Strubell et al., 2018). We therefore argue that explicit syntactic information (here we mainly focusing on utilizing syntactic dependencies) could enhance the translation quality of recent state-of-the-art NMT models.

Existing works incorporating explicit syntactic information in NMT models has been an active topic (Stahlberg et al., 2016; Aharoni and Goldberg, 2017; Li et al., 2017; Bastings et al., 2017; Chen et al., 2017; Wu et al., 2017, 2018; Zhang et al., 2019). However, they are mostly sophisticated in designing and have not proven their effectiveness in the latest structure(*i.e.*, Transformer). Recent studies have shown that graph neural networks (GNN) (Scarselli et al., 2009) and its variants (*e.g.*, graph convolutional network(GCN) (Kipf and Welling, 2016), graph recurrent network(GRN) (Zhang et al., 2018)) have benefited natural language representation (Battaglia et al., 2016; Hamilton et al., 2017; Marcheggiani and Titov, 2017; Marcheggiani et al., 2018; Beck et al., 2018; Song et al., 2018a,b, 2019) with high interpretability for non-Euclidean data structures. Despite these apparent successes, it still suffers from a major weakness: their graph layer assumes that nodes are distributed independently without explicit word order (*i.e.*, nodes within a graph layer essentially acting as non-recursive quasi-RNNCell in formula), overlooking internal sequential knowledge.

To overcome above issues, we presents a novel Recurrent Graph Syntax Encoder (RGSE), casting nodes in graph layer as RNNCells, which has the central approach of capturing syntactic dependencies and word order information simultaneously. Specifically, RGSE first receives each word’s representation of the original encoder and then makes each RNN node in RGSE layer obtain its dependency nodes (*i.e.*, words dependencies from the original encoder) and the previously hidden state

in the RGSE layer. RGSE could not only flexibly deployed over original encoder of recurrent NMT but also can be utilized on Transformer. Furthermore, RGSE could enhance the inductive learning ability for models since more syntax connections are provided to guide source-side meaning preservation and target-side word prediction. Our main contributions are summarized as follows:

- We propose a simple yet effective representation method, RGSE for NMT, which is done over a standard encoder (recurrent or transformer) and could inform the NMT model with comprehensive syntactic dependencies. The edge-wise integration, on the other hand, enables attentional decoder to pick essential source words for prediction.
- We develop a novel Transformer architecture that alternates the self-attention component with RGSE in the lower layers. The alternation allows the encoder capture more prior knowledge (*i.e.*, syntactic dependency information), improving the representation and induction ability for Transformer. The gated residual connection, on the other hand, yields fast convergence speed.
- Experiments on English-German (standard WMT14 and WMT16 News Commentary V11) and English-Czech (WMT16 News Commentary V11) translation tasks show consistent improvements over several strong syntax aware baselines, validating the effectiveness and universality of RGSE.

We conduct extensive experiments with different setups to find the optimal setting: having RGSE in one direction and in both directions; integrating incoming edges with different functions; and including dependencies from past (previous) or future (following) words. For the Transformer-based NMT (Vaswani et al., 2017), empirical experiments on validation set showed that replacing the self-attention component in the lower layers with RGSE performed better, probably because Transformer tend to capture some complex and long dependencies at higher layers but showing relatively poor dependencies modeling ability in lower layers (Raganato and Tiedemann, 2018). In doing so, our bidirectional edge-wise RGSE-equipped NMT models could achieve further improvements over several strong syntax-aware NMT models.

## 2 Background

Our model is based on the sequence-to-sequence framework (Sutskever et al., 2014; Bahdanau et al., 2015; Luong et al., 2016; Vaswani et al., 2017). In NMT, we normally employ an encoder with the assumption that it can adequately represent the source sentence. Then, the decoder can autoregressively predict each target word. This section will briefly review the “*neural encoder*” and “*graph syntax encoder*” respectively.

### 2.1 Neural Encoder

The NMT encoder intends to summarize the source semantics and dependencies such that the decoder could generate them with target words. We will describe two kinds of popular encoders (*i.e.*, *RNN encoder* (Kalchbrenner and Blunsom, 2013; Sutskever et al., 2014; Bahdanau et al., 2015; Wu et al., 2016) and *Self-Attentional Transformer encoder* (Vaswani et al., 2017)) in succession.

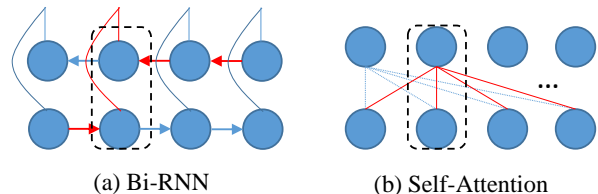

Figure 1: Simplified illustration of BiRNN (a) and Self-Attention encoder (b), the black dotted rectangle represents the node of current step, and the red line denotes the hidden state that can be perceived at that moment.

#### 2.1.1 RNN encoder

As is shown in Fig. 1, given an RNN encoder, we can bidirectionally model a sentence as follows:

$$\begin{aligned} \vec{h}_t &= \overrightarrow{RNN}(E_{src}x_t, \vec{h}_{t-1}), \\ \overleftarrow{h}_t &= \overleftarrow{RNN}(E_{src}x_t, \overleftarrow{h}_{t+1}) \end{aligned}$$

where  $x_t \in \{0, 1\}^{|V_{src}|}$  is the one-hot vector and  $E_{src}x_t \in \mathbb{R}^{|d_{emb}|}$  indicates the embedding of the  $t_{th}$  source word. Then, the above two vectors will be concatenated as  $\tilde{h}_t = [\vec{h}_t; \overleftarrow{h}_t]$  to represent the contextual information.

#### 2.1.2 Self-Attentional Transformer encoder

On the other hand, self-attention in Transformer (Vaswani et al., 2017) allows the encoder to model sentence representation parallelly. Each sub-layer consists of two main components: self-attention layer and feed-forward network. the self-

attention layer receives a list of vectors as inputs (See Fig. 1). For any sequence with length  $L$  containing  $m$  steps, the  $t_{th}$  word in the  $i_{th}$  layer can be denoted as:

$$z_t^{(i)} = \begin{cases} \sum_{m=1}^L \text{softmax}(\frac{\langle q_t, k_m \rangle}{\sqrt{d}}) v_t & i \geq 1 \\ \sqrt{d} \times E_{src} x_t + PE_t & i = 0 \end{cases}$$

where  $q_t$ ,  $k_m$  and  $v_t$  are equal to  $\theta_q h_t^{(i-1)}$ ,  $\theta_k h_m^{(i-1)}$ , and  $\theta_v h_t^{(i-1)}$ ; specifically, they refer to the query, key, and value in the  $i - 1$  layer and  $\theta$  stands for trainable weight matrix. The similarity between *query* and *key* can be evaluated by dot-product attention.  $PE$  is the fixed position embedding and its dimension  $d$  is consistent with the word embedding, defined as:

$$PE_{t,j} = \sin(t/10000^{2j/d}) \\ PE_{t,2j+1} = \cos(t/10000^{2j/d})$$

## 2.2 Graph Syntax Encoder

In NLP tasks, besides consecutive word order information, non-local neighbor relations (*e.g.*, dependency relations) are also crucial. To inform the model with non-local information, the graph structure networks are employed (Marcheggiani and Titov, 2017; Bastings et al., 2017; Song et al., 2018a; Beck et al., 2018; Song et al., 2019).

The syntax GCN layer is adopted to connect words with semantic dependencies over the original encoder (Bastings et al., 2017). Formally, the hidden state of node  $\nu$  with neighbor dependency nodes collection  $\mu \in N(\nu)$  can be described as:

$$h_\nu = \rho \left( \sum_{\mu} W_{dir(\mu,\nu)} h(\mu) + b_{lab(\mu,\nu)} \right)$$

where *dir* and *lab* refer to directionality and labels,  $\rho$  is the non-linear activation function, and trainable parameters were defined as  $W$  and  $b$ .

To capture non-local dependencies while propagating information in the recurrent network, we can sum the incoming and outgoing edges as input. For example, Song et al. (2018a, 2019) denotes the inputs for the input gate and output gates as  $x_\nu^i = \sum_{\mu \in N_{in}(\nu)} x_\mu$ ,  $x_\nu^o = \sum_{\mu \in N_{out}(\nu)} x_\mu$  in the transitioning process of the graph-state LSTM with a similar operation for hidden states  $h_\nu^i$  and  $h_\nu^o$ , where incoming and outgoing neighbors of  $\nu$  are denoted by  $N_{in}(\nu)$  and  $N_{out}(\nu)$ .

Similarly, Beck et al. (2018) applied gated GNN layer that directly received word and positional embeddings to represent dependency information.

With these effective graph structure strategies, the encoder can incorporate explicit non-local dependency information. However, their graph layers are essentially different with ours, assuming that nodes in each graph layer are orthogonal (*i.e.*, there is no sequential information propagation between nodes). Our RGSE could model both word order information and syntactic dependencies.

## 3 Recurrent Graph Syntax Encoder

Here, we present RGSE and explain how it is assembled in Recurrent NMT and Transformer.

### 3.1 RGSE for Recurrent NMT

As mentioned above, we choose RNN as the activation cell (more specifically GRU, as we follows the Recurrent NMT model settings of Bahdanau et al. (2015)), which means RGSE layer not only conveys non-local dependencies but also records the consecutiveness. Meanwhile, inspired by Wu et al. (2017, 2018) where they bidirectionally model the in-order sequence of the dependency tree, we believe that bidirectional propagation will enhance its representation ability.

For any input graph  $G = \langle V, E \rangle$ , we define vectors  $\tilde{h}$ ,  $\vec{s}$  and  $\overleftarrow{s}$  for each word  $\nu \in V$ , where  $\tilde{h}$  is from the previous encoder, bidirectional  $s$  represent forward and backward states in RGSE layer, and  $|V|$  is the length of the source sentence. For any pair of dependent words  $w_i \mapsto w_j$  in a sentence, nodes  $\vec{s}_j, \overleftarrow{s}_j$  will be activated; concurrently, two edges  $\xi_{(\tilde{h}_i, \vec{s}_j)}$  and  $\xi_{(\tilde{h}_i, \overleftarrow{s}_j)}$  will be generated. All incoming edges  $\xi \in E_{in}(s_j)$  for node  $s_j$  are integrated through three types of functions:

$$\phi(s_j) = \begin{cases} \sum_{E_{in}(s_j)} h_{\xi_{(\tilde{h}_i, s_j)}} & \text{sum} \\ \sum_{E_{in}(s_j)} 1/|N_{in}(s_j)| \cdot h_{\xi_{(\tilde{h}_i, s_j)}} & \text{average} \\ \sum_{E_{in}(s_j)} W_{h_{\xi_{(\tilde{h}_i, s_j)}}} \cdot h_{\xi_{(\tilde{h}_i, s_j)}} & \text{gated} \end{cases}$$

where hidden vector  $h$  is the value of  $\tilde{h}_i$  and  $W$  is trainable gating parameter. Then, the propaga-

tion processes in bidirectional RGSE are:

$$\begin{aligned}
\vec{z}_t &= \sigma(\vec{W}_z \vec{s}_{t-1} + \vec{U}_z \phi(\nu_t) + \vec{b}_z), \\
\leftarrow{z}_t &= \sigma(\leftarrow{W}_z \leftarrow{s}_{t+1} + \leftarrow{U}_z \phi(\nu_t) + \leftarrow{b}_z), \\
\vec{r}_t &= \sigma(\vec{W}_r \vec{s}_{t-1} + \vec{U}_r \phi(\nu_t) + \vec{b}_r), \\
\leftarrow{r}_t &= \sigma(\leftarrow{W}_r \leftarrow{s}_{t+1} + \leftarrow{U}_r \phi(\nu_t) + \leftarrow{b}_r), \\
\vec{s}'_t &= \tanh(\vec{W}_h \phi(\nu_t) + \vec{U}_h(\vec{r}_t \vec{s}_{t-1})), \\
\leftarrow{s}'_t &= \tanh(\leftarrow{W}_h \phi(\nu_t) + \leftarrow{U}_h(\leftarrow{r}_t \leftarrow{s}_{t+1})), \\
\vec{s}_t &= \vec{z}_t \cdot \vec{s}_{t-1} + (1 - \vec{z}_t) \cdot \vec{s}'_t, \\
\leftarrow{s}_t &= \leftarrow{z}_t \cdot \leftarrow{s}_{t+1} + (1 - \leftarrow{z}_t) \cdot \leftarrow{s}'_t, \\
\eta_t &= \tau(\vec{s}_t, \leftarrow{s}_t, \tilde{h}_t)
\end{aligned}$$

where  $\vec{s}_t$  and  $\leftarrow{s}_t$  are the outputs of forward and backward RGSE,  $\eta_t$  is the final state of encoder at time  $t$ , and  $\tau$  refers to the residual concatenation. Here we employ normal residual connection  $\tau_n(\cdot)$  (He et al., 2016):

$$\tau_n(\vec{s}, \leftarrow{s}, \tilde{h}) = \text{concat}(\vec{s} + \tilde{h}, \leftarrow{s} + \tilde{h})$$

and another alternative gated residual connection:

$$\begin{aligned}
\tau_g(\vec{s}, \leftarrow{s}, \tilde{h}) &= \text{concat}(\lambda_1 \vec{s} + (1 - \lambda_1) \tilde{h}, \\
&\quad \lambda_2 \leftarrow{s} + (1 - \lambda_2) \tilde{h})
\end{aligned}$$

where  $\lambda$  can be calculated as:

$$\lambda = \sigma(\omega \cdot s + \psi \cdot h)$$

$\omega$  and  $\psi$  are gating parameters. To further distinguish which directional RGSE layer is better and whether using past information or future information alone could enhance RGSE performance, we design the following four RGSE models: (In the following models, we give an example sentence “*monkey likes eating bananas*”, in which there exists three pairs of dependencies: “*monkey*  $\mapsto$  *like*, *eating*  $\mapsto$  *like*, and *bananas*  $\mapsto$  *eating*”)

**(i) Forward RGSE:** Fig. 2 illustrates the uni-layer forward-RGSE model (forward-RGSE, within the dashed rectangle). The original encoder reads embedded word vectors before connecting with the RGSE layer. As mentioned above, the integration function  $\phi(\cdot)$  was employed for each node to properly capture the incoming edges, where green edges represent past information and red edges show future information. For example, node  $\vec{s}_2$  in Fig. 2 receives both RGSE hidden state  $\vec{s}_1$  and dependency information, which includes current word “*like*” from the original encoder, past information “*monkey*”, and future information “*eating*”. After original encoding and

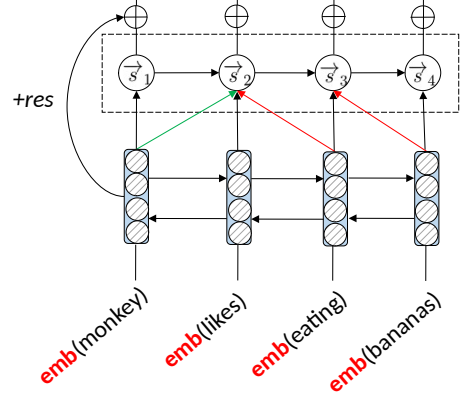

Figure 2: Uni-layer RGSE upon RNMT encoder.

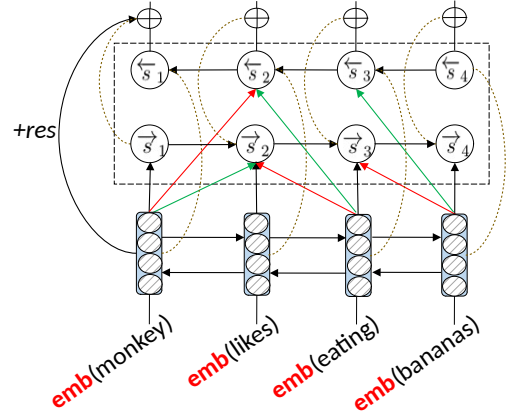

Figure 3: Bidirectional RGSE upon RNMT encoder.

RGSE modeling, uppermost layer  $\tau(\cdot)$  will combine them position-wisely.

**(ii) Bidirectional Total RGSE:** In order to make full use of the property of recurrent network, we intuitively add a reverse RGSE layer. Fig. 3 shows the bidirectional RGSE (called bi-total-RGSE). Both forward and backward RGSE layers read the hidden state and dependencies from the original encoder.

**(iii) Bidirectional Past RGSE:** Bidirectional past RGSE (bi-past-RGSE), unlike bi-total-RGSE, only gathers past edges (marked as green arrows). For example, although the backward node  $\leftarrow{s}_2$  has dependent relationships with “*monkey*” and “*eating*”,  $\leftarrow{s}_2$  only reads dependent edge  $\xi_{(h_3, \leftarrow{s}_2)}$  because, in reverse order, “*eating*” is the past information of “*like*”.

**(iv) Bidirectional Future RGSE:** Contrary to bi-past-RGSE, bi-future-RGSE reads future dependencies (marked as red arrows) only.



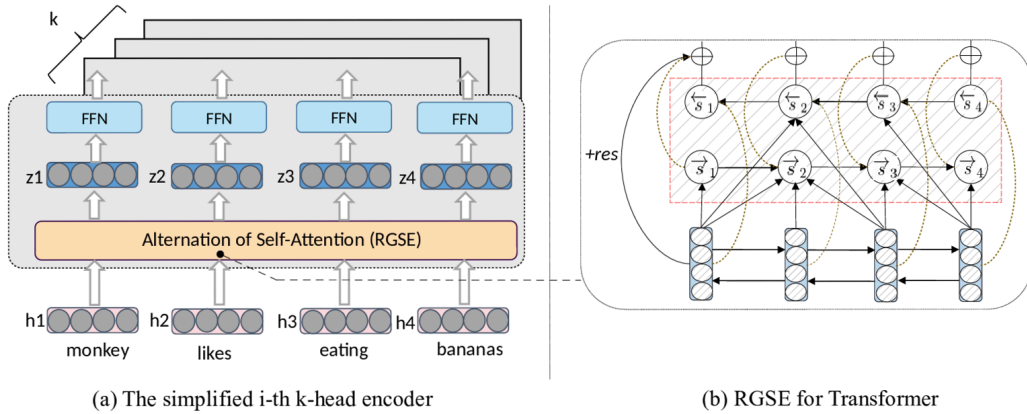

Figure 4: Illustration of RGSE-based Transformer encoder. (a) is the simplified  $i_{th}$  encoder layer of the Transformer, which receives the hidden state of each word from previous layer. FFN refers to the feed forward networks and  $k$  is multi-head number. (b) shows how the bi-total-RGSE upon bi-GRU layer replace the self-attention.

### 3.2 RGSE for Transformer

Although Transformer has achieved the state-of-the-art performance, it possesses the innate disadvantage on sequential modeling. Taking sentence “*I bought a new **book** with a new friend*” for instance, during modeling word “**book**” with positional embedding removed self-attention, it will pay same attention on two “**new**” while the true case is it only needs to pay attention to the first “**new**”. To improve this issue, Shaw et al. (2018) proposed relative position for Transformer and Yang et al. (2018) introduced Gaussian bias into encoder layers as prior constraint.

It is linguistic intuition that the syntax information could enhance the representation ability. Domhan (2018) reported that replacing the self-attention layer with RNN in the encoder could deliver comparable results to the vanilla Transformer. We assume that adding bi-total-RGSE to the bi-GRU-replaced Transformer (see Fig. 4) could be helpful. In addition, we also investigated which level of layers benefit most from RGSE in experiments.

## 4 Experiments

The aims of experiments are (1) finding the optimal structure of RGSE on validation data set (2) proving the superiority of RGSE over existing tree&graph-structure syntax-aware models (3) assessing the effectiveness of RGSE-based Transformer compared with several SOTA models.

### 4.1 Setup

To compare with the results reported by previous works (Bastings et al., 2017; Beck et al., 2018)

under the recurrent NMT scenario, we conduct experiments on News Commentary V11 corpora from WMT16<sup>1</sup>, comprising approximate 226K En-De and 118K En-Cs sentence pairs respectively, where the data and settings are consistent with them. We employ SyntaxNet<sup>2</sup> to tokenize and parse English side data while German and Czech corpora are segmented by byte-pair encodings (BPE) (Sennrich et al., 2016), where we use 8K BPE merges to avoid OOV problem. Further preprocessing details follow Bastings et al. (2017). As comparison, we reimplemented SE-NMT (Wu et al., 2017, 2018) where they employed MLP function to concatenate four hidden states (forward/reverse in-order traversal, pre-order traversal and post-order traversal from syntax dependency tree) and trained Tree2Seq (Chen et al., 2017) model with their released code<sup>3</sup>. We also conduct Transformer-based experiments on NC-v11 dataset as reference.

To assess the effectiveness of RGSE on advanced Transformer-based model (Vaswani et al., 2017) and fairly compare with other state-of-the-art models (Shaw et al., 2018; Yang et al., 2018), we implement RGSE equipped Transformer on top of an open-source toolkit OpenNMT<sup>4</sup> (Klein et al., 2017). We followed Vaswani et al. (2017) to set the configurations and report results on

<sup>1</sup><http://www.statmt.org/wmt16/translation-task.html>

<sup>2</sup><https://github.com/tensorflow/models/tree/master/research/syntaxnet>

<sup>3</sup><https://github.com/howardchenhd/Syntax-awared-NMT>

<sup>4</sup><https://github.com/OpenNMT/OpenNMT-py>

standard WMT14 English $\Rightarrow$ German task<sup>5</sup>, which consists of 4.5M sentences pairs. Here we processed the BPE with 32K merge operations for both language pairs<sup>6</sup>. For fair comparison, here we also implement the key idea of Bastings et al. (2017) into Transformer framework in two ways: one is similar to our approach, replacing self-attention with “BiRNN+GCN”, another is simply adding GCN upon self-attention layer (followed the same edge dropout rate 0.2) before feed-forward-network processing. All models were trained on 6 NVIDIA V100 GPUs, where the batch size is 4096 tokens. Note thea the 4-gram NIST BLEU score (Papineni et al., 2002) is applied as the evaluation metric for all models.

## 4.2 Ablation Study

To achieve the aim (1), we first evaluated the effects of internal functions on RGSE, then assessed which level of layers is most beneficial to be applied RGSE on Transformer. The results are reported on validation set and trained with News Commentary V11 English $\Rightarrow$ German corpora.

**Effects of internal functions.** Which integration function  $\phi(\cdot)$  is more helpful? What kind of residual connection method  $\tau(\cdot)$  helps to improve translation? Fig. 5 illustrates the performance of different integration functions on the NC-v11 En-De validation set. Comparisons show that the combination of the edge-wise integration function and gated residual connection most benefits our task. Therefore, the following experiments will use the edge-wise integration function and gated residual connection as the default configuration.

**Effects of different level of layers.** Anastasopoulos and Chiang (2018) stated that high-level layers exploit more structure information and more long-distance dependencies than lower layers. We thus design ablation study to investigate if it is necessary to deploy RGSE on every layer. As is shown in Tab. 1, modeling the first three layers with RGSE in Transformer can achieve the best performance. This result is consistent with Yang et al. (2018)’s findings, validating our assumption.

## 4.3 Main Results

To achieve aim (2), we first report and analyze the BLEU scores on NC-v11 En-De and En-Cs test

<sup>5</sup><https://nlp.stanford.edu/projects/nmt>

<sup>6</sup>The label will remain on each substring if a word is split by BPE.



Figure 5: Validation BLEU of different settings for En-De NC-v11, where the baselines are Recurrent and Transformer NMT. Beyond baselines, other RGSE systems mean bi-total-RGSE structure. *sum*, *ave.*, and *gated* refer to three types of integration function  $\phi(\cdot)$ , symbols  $+N$  and  $+G$  signify normal residual connection  $\tau_n(\cdot)$  and gated residual connection  $\tau_g(\cdot)$ , respectively. Note that RGSE component applied to every layer for Transformer-based model in ablation study.

#	Layers	Speed	Val.	$\Delta$
1	[1-6]	1.52	19.80	-
2	[1-1]	1.41	19.89	+0.09
3	[1-2]	1.43	19.94	+0.14
4	[1-3]	1.43	<b>20.01</b>	<b>+0.21</b>
5	[1-4]	1.46	19.89	+0.19
6	[4-6]	1.42	19.91	+0.11

Table 1: Different settings that employed RGSE on different layer combinations in Transformer. “speed” denotes training speed measured in steps per second.

sets. Then we would compare with several SOTA systems on standard WMT14 En-De dataset to accomplish aim (3).

Tab.2 proves the effectiveness of RGSE model on NC-v11 dataset and its superiority over existing works (both tree-based and graph-based syntax-aware models). Unsurprisingly, SMT performs the worst. The tree-based models (*i.e.*, Tree2Seq(Chen et al., 2017), SE-NMT(Wu et al., 2018)) and graph-based models (*i.e.*, BiRNN+GCN(Bastings et al., 2017), Gated-GNN(Beck et al., 2018)) easily outperform the SMT and BiRNN as expected. In this work, for proving that the performance gains are not due to increased number of parameters, we employ Bi-RNN with 2 layers encoder as baseline system as its parameter scale is larger than ours, and besides this, other settings all employed 1 layer BiRNN encoder. Results of several

	System	En-De		En-Cs	
		BLEU	#para.	BLEU	#para.
<i>existing works</i>	PB-SMT (Beck et al., 2018)	12.8	n/a	8.6	n/a
	Bi-RNN (Bastings et al., 2017)	14.9	n/a	8.9	n/a
	Bi-RNN + GCN (Bastings et al., 2017)	16.1	n/a	9.6	n/a
	Tree2Seq (Chen et al., 2017)	15.9	40.8M	9.4	38.1M
	SE-NMT (Wu et al., 2018)	16.4	42.5M	9.7	39.1M
	Gated-GNN2S (Beck et al., 2018)	16.7	41.2M	9.8	38.8M
<i>this work</i>	Bi-RNN (2 layers encoder)	15.5	62.3M	9.3	58.2M
	Bi-RNN + forward RGSE	16.0	41.4M	9.7	39.2M
	Bi-RNN + bi past RGSE	16.5 <sup>↑</sup>	45.6M	10.1 <sup>↑</sup>	42.1M
	Bi-RNN + bi future RGSE	16.8 <sup>↑</sup>	45.4M	10.3 <sup>↑</sup>	42.5M
	Bi-RNN + bi total RGSE	17.7 <sup>↑</sup>	52.2M	11.1 <sup>↑</sup>	49.8M
	Transformer-base	18.9	80.7M	11.6	76.0M
	+bi total RGSE	19.8 <sup>↑</sup>	83.2M	12.4 <sup>↑</sup>	78.4M

Table 2: Experiments on NC-v11 dataset. “<sup>↑</sup> / <sup>↑↑</sup>”: significantly outperform their counterpart ( $p < 0.05/0.01$ ).

GRSE models confirm that forward-RGSE, bi-past-RGSE, bi-future-RGSE and bi-total-RGSE are progressively improve translation. Most notably, it outperforms the strong baseline by +2.2 and + 1.8 points on En-De and En-Cs tasks respectively and bi-total-RGSE significantly exceeds existing syntax-aware models. To verify universality of RGSE, we also conduct experiments on Transformer and compare with RGSE-equipped Transformer. Experiments show adding RGSE could make the Transformer obtain +0.9 BLEU on En-De and +0.8 BLEU on En-Cs.

In addition, we also conducted experiments on WMT14 En-De dataset to assess our model performance compared with several state-of-the-art systems. Tab. 3 presents recent popular models (Wu et al., 2016; Gehring et al., 2017; Vaswani et al., 2017; Shaw et al., 2018; Yang et al., 2018; Ahmed et al., 2018; Wu et al., 2019). For fairly comparing with existing syntax incorporating method (Bastings et al., 2017), we reproduce BiRNN Transformer, BiRNN+GCN Transformer in lower layers ([1–3]). Notably, RGSE-based Transformer-big model surpasses several existing powerful models, and even achieves the competitive result compared to the most advanced DYNAMCONV model (Wu et al., 2019).

#### 4.4 Analysis

We further analyze two questions in this section: (1) which type of dependency information is more important? past or future? and (2) can RGSE improve the translation quality of long sentences?

System	BLEU	#para.
GNMT(Wu et al., 2016)	26.30	n/a
ConvS2S(Gehring et al., 2017)	26.36	n/a
Transformer-base	27.64	88.0M
+Rel_Pos(Shaw et al., 2018)	27.94	88.1M
+Localness(Yang et al., 2018)	28.11	88.8M
Weighted(Ahmed et al., 2018)	28.40	n/a
Transformer-big	28.58	264.1M
+Localness(Yang et al., 2018)	28.89	267.4M
Weighted(Ahmed et al., 2018)	28.90	n/a
LightConv(Wu et al., 2019)	28.90	n/a
DynamConv(Wu et al., 2019)	29.70	n/a
<i>this work (below)</i>		
Transformer-base	27.65	90.2M
+ GCN	27.87	90.4M
+ BiRNN+GCN	27.92	91.2M
+ RGSE (ours)	28.62 <sup>↑</sup>	91.76M
Transformer-big	28.60	272.1M
+ RGSE(ours)	29.47 <sup>↑</sup>	278.3M

Table 3: Comparing with several SOTA models on WMT14 En-De test sets. “<sup>↑</sup> / <sup>↑↑</sup>”: significantly outperform their counterpart ( $p < 0.05/0.01$ ).

##### 4.4.1 Past vs. Future

Interesting results in Tab.2 show that future information is somewhat more instructive compared to past information. We assume the reason is that for Subject-Verb-Object languages (*e.g.*, English) future dependencies make the encoder preserve more meaningful presentations, the decoder hence can have more far-sighted predictions.

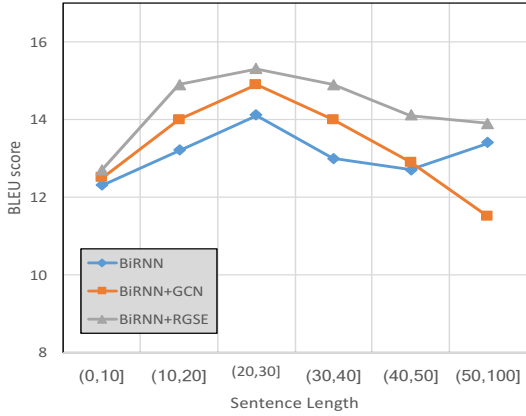

Figure 6: BLEU scores of the generated translations on NC-v11 En-De test set.

#### 4.4.2 Long Sentence Translation

Following Bahdanau et al. (2015), we divide test sentences w.r.t their lengths. Fig. 6 indicates that RGSE-based system outperforms others when tackling long sentences, verifying our assumption that the graph nodes with recurrent dependencies can better represent long distance information.

The reason why they perform poorly when the length exceeds 50 is that the length limitation of the training corpus is 50, making it hard for the model to cope with long sentences.

## 5 Related Work

The RGSE is inspired by two research themes:

**Incorporating linguistic features :** Several approaches have incorporated linguistic features into NMT models since Tai et al. (2015) demonstrated that incorporating structured semantic information could enhance the representations. Sennrich and Haddow (2016) fed the encoder cell combined embeddings of linguistic features including lemmas, subword tags, etc. Eriguchi et al. (2016) employed the tree-based encoder to model syntactic structure. Li et al. (2017) showed that stitching the word and linearization of parse tree is a effective method to incorporate syntax. Zaremoondi and Haffari (2018); Ma et al. (2018) utilized a forest-to-sequence model, which encoded a collection of packed parse trees to compensate for the parser errors, which was superior to the tree-based model. But their works does not utilize graph network to model structured data. Jointly learning of both semantic information and attentional translation is another prevalent approach that appropriately introduces linguistic knowledge. To the best

of our knowledge, Luong et al. (2016) first proposed adding source syntax into NMT with a sharing encoder. Niehues and Cho (2017) trained the machine translation system with POS and named-entities(NE) tasks at the same time, gaining considerable improvements in multiple tasks. Zhang et al. (2019) concatenated the original NMT word representation and the syntax-aware word representation derived from the well-trained dependency parser. However, they considered more implicit information, overlooking the importance of explicit prior knowledge, and have not proven their effectiveness in the Transformer.

**NMT with graph representation :** This paper mainly extends the idea of (Bastings et al., 2017), which regarded encoded vectors of each word as graph nodes and took them with syntactic dependencies as GCN inputs. Following this, Marcheggiani et al. (2018) obtained better performance by using syntactic and semantic (semantic-role structures) GCNs together, and Beck et al. (2018) improved the representing ability of the encoder through gated GNN with AMR information included. Although they realized that explicit linguistic information could enhance the natural language modeling, their graph node essentially act as a non-recursive quasi-RNNCell in formula, overlooking the internal sequential information between nodes.

In this study, we introduce more flexible strategies for both Recurrent NMT and Transformer, yielding better results than above independent-node graph modelings.

## 6 Conclusions and Future Work

We present a simple yet effective approach, Recurrent Graph Syntax Encoder (RGSE), to inform NMT models with explicit syntactic dependency information. The proposed RGSE is a migratable component on the encoder side which regards RNNCells as graph nodes and injects syntactic dependencies as edges, thereby capturing syntactic information and word order information simultaneously. Our experiments on En-De and En-Cs tasks show that RGSE consistently enhances recurrent NMT (Bahdanau et al., 2015) and Transformer (Vaswani et al., 2017), achieving the competitive results on par with the SOTA model.

In future work, it will be interesting to apply RGSE to other natural language generation tasks, such as text summarization and conversation.



## References

- Roei Aharoni and Yoav Goldberg. 2017. Towards string-to-tree neural machine translation. In *Proceedings of the 55th Annual Meeting of the Association for Computational Linguistics (Volume 2: Short Papers)*, pages 132–140, Vancouver, Canada. Association for Computational Linguistics.
- Karim Ahmed, Nitish Shirish Keskar, and Richard Socher. 2018. Weighted transformer network for machine translation.
- Antonios Anastasopoulos and David Chiang. 2018. Tied multitask learning for neural speech translation. In *Proceedings of the 2018 Conference of the North American Chapter of the Association for Computational Linguistics: Human Language Technologies, Volume 1 (Long Papers)*, pages 82–91.
- Dzmitry Bahdanau, KyungHyun Cho, and Yoshua Bengio. 2015. Neural machine translation by jointly learning to align and translate. In *Proceedings of ICLR 2015*.
- Joost Bastings, Ivan Titov, Wilker Aziz, Diego Marcheggiani, and Khalil Simaan. 2017. Graph convolutional encoders for syntax-aware neural machine translation. In *Proceedings of EMNLP 2017*.
- Peter Battaglia, Razvan Pascanu, Matthew Lai, Danilo Jimenez Rezende, et al. 2016. Interaction networks for learning about objects, relations and physics. In *Proceedings of NIPS 2016*, pages 4502–4510.
- Daniel Beck, Gholamreza Haffari, and Trevor Cohn. 2018. Graph-to-sequence learning using gated graph neural networks. In *Proceedings of ACL 2018*.
- Huadong Chen, Shujian Huang, David Chiang, and Jiajun Chen. 2017. Improved neural machine translation with a syntax-aware encoder and decoder. In *Proceedings of ACL 2017*, pages 1936–1945.
- Tobias Domhan. 2018. How much attention do you need? a granular analysis of neural machine translation architectures. In *Proceedings of ACL 2018*.
- Akiko Eriguchi, Kazuma Hashimoto, and Yoshimasa Tsuruoka. 2016. Tree-to-sequence attentional neural machine translation. In *Proceedings of ACL 2016*, pages 823–833.
- Jonas Gehring, Michael Auli, David Grangier, Denis Yarats, and Yann N Dauphin. 2017. Convolutional sequence to sequence learning. In *Proceedings of ICML 2017*.
- William L. Hamilton, Rex Ying, and Jure Leskovec. 2017. Inductive representation learning on large graphs. In *Proceedings of NIPS 2017*.
- Kaiming He, Xiangyu Zhang, Shaoqing Ren, and Jian Sun. 2016. Deep residual learning for image recognition. In *Proceedings of CVPR 2016*, pages 770–778.
- Nal Kalchbrenner and Phil Blunsom. 2013. Recurrent continuous translation models. In *Proceedings of EMNLP 2013*, pages 1700–1709.
- Thomas N Kipf and Max Welling. 2016. Semi-supervised classification with graph convolutional networks. *arXiv preprint arXiv:1609.02907*.
- Guillaume Klein, Yoon Kim, Yuntian Deng, Jean Senellart, and Alexander M. Rush. 2017. OpenNMT: Open-source toolkit for neural machine translation. In *Proc. ACL*.
- Adhiguna Kuncoro, Chris Dyer, John Hale, Dani Yogatama, Stephen Clark, and Phil Blunsom. 2018. Lstms can learn syntax-sensitive dependencies well, but modeling structure makes them better. In *Proceedings of the 56th Annual Meeting of the Association for Computational Linguistics (Volume 1: Long Papers)*, pages 1426–1436.
- Junhui Li, Deyi Xiong, Zhaopeng Tu, Muhua Zhu, Min Zhang, and Guodong Zhou. 2017. Modeling source syntax for neural machine translation. In *Proceedings of ACL 2017*, pages 688–697.
- Tal Linzen, Emmanuel Dupoux, and Yoav Goldberg. 2016. Assessing the ability of lstms to learn syntax-sensitive dependencies. *Transactions of the Association for Computational Linguistics*, 4:521–535.
- Minh-Thang Luong, Quoc V. Le, Ilya Sutskever, Oriol Vinyals, and Lukasz Kaiser. 2016. Multi-task sequence to sequence learning. In *Proceedings of ICLR 2016*.
- Chunpeng Ma, Akihiro Tamura, Masao Utiyama, Tiejun Zhao, and Eiichiro Sumita. 2018. Forest-based neural machine translation. In *Proceedings of ACL 2018*.
- Diego Marcheggiani, Joost Bastings, and Ivan Titov. 2018. Exploiting semantics in neural machine translation with graph convolutional networks. In *Proceedings of NAACL 2018*.
- Diego Marcheggiani and Ivan Titov. 2017. Encoding sentences with graph convolutional networks for semantic role labeling. In *Proceedings of EMNLP 2017*, pages 1506–1515.
- Jan Niehues and Eunah Cho. 2017. Exploiting linguistic resources for neural machine translation using multi-task learning. In *Proceedings of the WMT 2017*.
- Kishore Papineni, Salim Roukos, Todd Ward, and Wei-Jing Zhu. 2002. Bleu: A method for automatic evaluation of machine translation. In *Proceedings of ACL 2002*, pages 311–318.
- Alessandro Raganato and Jörg Tiedemann. 2018. An analysis of encoder representations in transformer-based machine translation. In *Proceedings of the 2018 EMNLP Workshop BlackboxNLP: Analyzing and Interpreting Neural Networks for NLP*, pages 287–297.

- Franco Scarselli, Marco Gori, Ah Chung Tsoi, Markus Hagenbuchner, and Gabriele Monfardini. 2009. The graph neural network model. *IEEE Transactions on Neural Networks*, 20(1):61–80.
- Rico Sennrich and Barry Haddow. 2016. Linguistic input features improve neural machine translation. In *Proceedings of the WMT 2016*, pages 83–91.
- Rico Sennrich, Barry Haddow, and Alexandra Birch. 2016. Neural machine translation of rare words with subword units. In *Proceedings of the 54th Annual Meeting of the Association for Computational Linguistics (Volume 1: Long Papers)*, volume 1, pages 1715–1725.
- Peter Shaw, Jakob Uszkoreit, and Ashish Vaswani. 2018. Self-attention with relative position representations. In *Proceedings of the 2018 Conference of the North American Chapter of the Association for Computational Linguistics: Human Language Technologies, Volume 2 (Short Papers)*, pages 464–468.
- Xing Shi, Inkit Padhi, and Kevin Knight. 2016. Does string-based neural mt learn source syntax? In *Proceedings of the 2016 Conference on Empirical Methods in Natural Language Processing*, pages 1526–1534.
- Lin Feng Song, Daniel Gildea, Yue Zhang, Zhiguo Wang, and Jinsong Su. 2019. Semantic neural machine translation using amr. *arXiv preprint arXiv:1902.07282*.
- Lin Feng Song, Yue Zhang, Zhiguo Wang, and Daniel Gildea. 2018a. A graph-to-sequence model for amr-to-text generation. In *Proceedings of ACL 2018*.
- Lin Feng Song, Yue Zhang, Zhiguo Wang, and Daniel Gildea. 2018b. N-ary relation extraction using graph state lstm. In *Proceedings of EMNLP 2018*.
- Felix Stahlberg, Eva Hasler, Aurelien Waite, and Bill Byrne. 2016. Syntactically guided neural machine translation. In *Proceedings of the 54th Annual Meeting of the Association for Computational Linguistics (Volume 2: Short Papers)*, pages 299–305, Berlin, Germany. Association for Computational Linguistics.
- Emma Strubell, Patrick Verga, Daniel Andor, David Weiss, and Andrew McCallum. 2018. Linguistically-informed self-attention for semantic role labeling. *arXiv preprint arXiv:1804.08199*.
- Ilya Sutskever, Oriol Vinyals, and Quoc V Le. 2014. Sequence to sequence learning with neural networks. In *Proceedings of NIPS 2014*, pages 3104–3112.
- Kai Sheng Tai, Richard Socher, and Christopher D. Manning. 2015. Improved semantic representations from tree-structured long short-term memory networks. In *Proceedings of ACL 2015*.
- Ashish Vaswani, Noam Shazeer, Niki Parmar, Jakob Uszkoreit, Llion Jones, Aidan N Gomez, Lukasz Kaiser, and Illia Polosukhin. 2017. Attention is all you need. In *Proceedings of NIPS 2017*.
- Felix Wu, Angela Fan, Alexei Baevski, Yann N Dauphin, and Michael Auli. 2019. Pay less attention with lightweight and dynamic convolutions. *arXiv preprint arXiv:1901.10430*.
- Shuangzhi Wu, Dongdong Zhang, Zhirui Zhang, Nan Yang, Mu Li, and Ming Zhou. 2018. Dependency-to-dependency neural machine translation. *IEEE/ACM Trans. Audio, Speech and Lang. Proc.*, 26(11):2132–2141.
- Shuangzhi Wu, Ming Zhou, and Dongdong Zhang. 2017. Improved neural machine translation with source syntax. In *IJCAI*, pages 4179–4185.
- Yonghui Wu, Mike Schuster, Zhifeng Chen, Quoc V. Le, Mohammad Norouzi, Wolfgang Macherey, Maxim Krikun, Yuan Cao, Qin Gao, Klaus Macherey, Jeff Klingner, Apurva Shah, Melvin Johnson, et al. 2016. Google’s neural machine translation system: Bridging the gap between human and machine translation. In *Proceedings of NIPS 2016*.
- Baosong Yang, Zhaopeng Tu, Derek F Wong, Fandong Meng, Lidia S Chao, and Tong Zhang. 2018. Modeling localness for self-attention networks. In *Proceedings of the 2018 Conference on Empirical Methods in Natural Language Processing*, pages 4449–4458.
- Poorya Zaremoondi and Gholamreza Haffari. 2018. Incorporating syntactic uncertainty in neural machine translation with a forest-to-sequence model. In *Proceedings of COLING 2018*, pages 1421–1429.
- Meishan Zhang, Zhenghua Li, Guohong Fu, and Min Zhang. 2019. Syntax-enhanced neural machine translation with syntax-aware word representations. *arXiv preprint arXiv:1905.02878*.
- Yue Zhang, Qi Liu, and Lin Feng Song. 2018. Sentence-state lstm for text representation. In *Proceedings of the 56th Annual Meeting of the Association for Computational Linguistics (Volume 1: Long Papers)*, pages 317–327.