

INVARIANTS OF 4-MANIFOLDS FROM KHOVANOV–ROZANSKY LINK HOMOLOGY

SCOTT MORRISON, KEVIN WALKER, AND PAUL WEDRICH

ABSTRACT. We use Khovanov–Rozansky \mathfrak{gl}_N link homology to define invariants of oriented smooth 4-manifolds, as skein modules constructed from certain 4-categories with well-behaved duals.

The technical heart of this construction is a proof of the sweep-around property, which makes these link homologies well defined in the 3-sphere.

CONTENTS

1. Introduction	1
2. Technology	5
3. The sweep-around move	8
4. Khovanov–Rozansky homology in S^3	14
5. A TQFT in dimensions $4 + \epsilon$	19
6. A pivotal braided monoidal 2-category	26
References	31

1. INTRODUCTION

Following the seminal articles of Jones, Witten, and Atiyah [Jon85, Wit89, Ati88], Crane and Frenkel outlined their vision for an algebraic construction of invariants of smooth 4-dimensional manifolds [CF94, Cra95], inspired by the initial signs of categorification they saw in Lusztig’s theory of canonical bases [Lus93]. A major milestone towards this goal was Khovanov’s celebrated categorification of the Jones polynomial [Kho00]—now known as *Khovanov homology*—which has since been rediscovered or reconstructed in many parts of mathematics and theoretical physics, see e.g. Stroppel [Str05, Str09], Gukov–Schwarz–Vafa [GSV05], Seidel–Smith [SS06] and Abouzaid–Smith [AS19], Cautis–Kamnitzer [CK08a, CK08b], and Witten [Wit12]. Rasmussen’s construction of his slice genus bound [Ras10] demonstrates that Khovanov homology is sensitive to 4-dimensional smooth structure and shares similarities with invariants defined using gauge theory—two impressions that have since been supported by subsequent work, such as the unknot detection theorem of Kronheimer–Mrowka [KM11].

The purpose of this article is to construct a family of bigraded abelian groups $\mathcal{S}_0^N(W; L)$, depending on an oriented smooth 4-manifold W and a framed oriented link L in its boundary, from on the Khovanov–Rozansky \mathfrak{gl}_N link homology theories [KR08] (which specialize to Khovanov homology at $N = 2$). Our construction has three steps. First we establish the functoriality of Khovanov–Rozansky link homology theories under link cobordisms in $S^3 \times [0, 1]$. In the second step we use these functorial invariants to construct certain 4-categories, which are the algebraic objects that encode the invariant $\mathcal{S}_0^N(B^4; L)$ for the 4-ball along with the operations induced by gluing 4-balls. In the third step, we integrate his local data over an oriented smooth 4-manifold using standard colimit/skein techniques to produce the invariant $\mathcal{S}_0^N(W; L)$, which should be thought of as the Hilbert space of an associated $4+\epsilon$ -dimensional TQFT.

As the notation suggests, there are also bigraded abelian groups $\mathcal{S}_i^N(W; L)$ for $i > 0$, defined using the *blob homology* construction of Morrison–Walker [MW12], which we will not pursue in this paper. Another idea left for future work concerns a lift to a fully homotopy-coherent theory valued in chain complexes rather than abelian groups, which we will comment on below.

The conceptual innovation here is the identification of a property that ensures that a 4-category has sufficiently well-behaved duality, allowing us to integrate it over an oriented smooth 4-manifold. This property, which we call the *sweep-around property*, is relevant in each of the two axiomatizations of 4-categories with duals we describe below.

Our computational advance is an explicit verification of this property for the 4-categories built from Khovanov–Rozansky link homology, specifically that link cobordisms represented by movies of the form

$$(1.1) \quad \boxed{\begin{array}{|c|c|c|c|c|c|c|} \hline \text{[Diagram 1]} & \text{[Diagram 2]} & \text{[Diagram 3]} & \text{[Diagram 4]} & \text{[Diagram 5]} & \text{[Diagram 6]} & \text{[Diagram 7]} \\ \hline \end{array}}$$

induce identity maps on the level of link homology. For a link homology theory, this property is equivalent to functoriality under link cobordisms in $S^3 \times [0, 1]$, which has important consequences beyond the scope of this paper, such as the injectivity of maps induced by ribbon concordances, see Kang [Kan19].

Link homology in the 3-sphere. In the following we give an outline of the construction. We start with the Khovanov–Rozansky link homologies, which are categorifications of the \mathfrak{gl}_N quantum link invariants of Reshetikhin–Turaev [RT90]. These link homologies take the shape of functors

$$\left\{ \begin{array}{l} \text{framed oriented link embeddings in } \mathbb{R}^3 \\ \text{oriented link cobordisms in } \mathbb{R}^3 \times [0, 1] \text{ up to isotopy rel } \partial \end{array} \right\} \xrightarrow{\text{KhR}_N} \left\{ \begin{array}{l} \text{bigraded abelian groups} \\ \text{homogeneous homomorphisms} \end{array} \right\}$$

which were constructed by Ehrig–Tubbenhauer–Wedrich in [ETW18] following earlier work on functoriality by Bar-Natan [BN05], Clark–Morrison–Walker [CMW09], and Blanchet [Bla10], and using technology developed by Robert–Wagner [RW20] and Rose–Wedrich [RW16] following Mackaay–Stošić–Vaz [MSV09], Lauda–Queffelec–Rose [LQR15], and Queffelec–Rose [QR16].

It is worth emphasizing that the functors KhR_N considered here are defined combinatorially and normalized to be sensitive to framing changes, in contrast to earlier incarnations of Khovanov–Rozansky homology. In the following, all links are oriented and framed and all link cobordisms are oriented.

The first step in our construction is to show that Khovanov–Rozansky homologies make sense as *functorial invariants of links in S^3* , rather than just in \mathbb{R}^3 . From the point of view of link embeddings and link cobordisms, there is not much difference between these two cases. A generic link embedding will miss the point ∞ if we consider $\mathbb{R}^3 = S^3 \setminus \{\infty\}$ and a generic link cobordism embedded in $S^3 \times [0, 1]$ will miss $\{\infty\} \times [0, 1]$. However, the analogous statement is no longer true for isotopies of link cobordisms. While link embeddings and their cobordisms can be represented by link diagrams in \mathbb{R}^2 and movies between them, there are additional isotopies of link cobordisms in $S^3 \times [0, 1]$, that do not exist in $\mathbb{R}^3 \times [0, 1]$. In addition to the standard Carter–Rieger–Saito movie moves [CS93, CRS97], a link homology theory that is functorial in S^3 additionally has to satisfy the so-called *sweep-around move* (1.1), which encodes a small isotopy of a sheet of link cobordism through $\infty \times [0, 1]$. The central technical result that we prove in §3 is the following.

Theorem 1.1. *The Khovanov–Rozansky link homologies satisfy the sweep-around move, i.e. they associate identity maps to link cobordisms represented by movies of the form (1.1).*

This move is significantly more complex than any of the Carter–Saito movie moves because it lacks any locality after the projection to \mathbb{R}^2 , and thus has to be checked for any tangle T with two endpoints. We do this in §3 and thereby also demonstrate how computable cobordism maps in Khovanov–Rozansky homology have become.

4-categories. The main tool in constructing the 4-manifold invariants \mathcal{S}_0^N is a family of 4-categories with sufficiently well-behaved duals. This is in analogy with the case of quantum invariants of 3-manifolds, which—in one way or another—all depend on a suitable 3-category, such as the ribbon category $\text{Rep}(U_q(\mathfrak{gl}_N))$ of finite-dimensional representations of quantum \mathfrak{gl}_N .

In fact, the 4-categories we construct should be thought of as *categorified representation categories*¹ of quantum \mathfrak{gl}_N . They are defined to have unique 0- and 1-morphisms and

- 2-morphisms are indexed by finite sets of points in a disk,
- 3-morphisms are indexed by tangles in a ball,
- 4-morphisms between two tangles T_1 and T_2 are elements of the Khovanov–Rozansky homology $\text{KhR}_N(T_1 \sqcup \overline{T_2})$ of the link obtained by reflecting T_2 and gluing it with T_1 along their corresponding endpoints.

The various ways of composing k -morphisms are purely geometric for $k \leq 3$ and use certain cobordism maps between Khovanov–Rozansky homologies to define composition of 4-morphisms. We give two constructions of such 4-categories, following the axioms of a disklike 4-category in §5 and of a braided monoidal 2-category in §6.

We invite the reader to use Khovanov–Rozansky link homology to build interesting examples of 4-categories following different axiomatizations, and to explore the appropriate incarnations of the sweep-around property in these settings.

The skein invariant. The construction of the 4-manifold invariant \mathcal{S}_0^N is most straightforward when using the setting of a disklike 4-category or the related notion of a *lasagna algebra*, a 4-dimensional analog of a planar algebra which we introduce in §5. Indeed, the bigraded abelian group $\mathcal{S}_0^N(W; L)$ is constructed as a skein module (inspired by the 3-dimensional analogs of Conway, Przytycki [Prz91] and Turaev [Tur91]) spanned by certain decorated surfaces in W bounding L , which we call *lasagna fillings*, modulo skein relations imposed by the operad structure of the lasagna algebra.

More generally, there are bigraded abelian groups $\mathcal{S}_i^N(W; L)$ for $i \geq 1$ that arise as homology groups of the blob complex defined in [MW12] and can be thought of as higher derived analogs of $\mathcal{S}_0^N(W; L)$. In fact, the construction of the blob complex was motivated by the idea of using the $\mathcal{S}_i^N(W; L)$ as tools for computing $\mathcal{S}_0^N(W; L)$. We can think of $\mathcal{S}_i^N(W; L)$ as analogous to the i -th Hochschild homology HH_i , where the input algebra of the Hochschild construction has been replaced by the 4-category derived from KhR_N and the implicit circle in the Hochschild construction has been replaced by the 4-manifold W . In particular, when W is the standard 4-ball, so L is a link in the 3-sphere, then $\mathcal{S}_0^N(B^4; L)$ is isomorphic to the usual Khovanov–Rozansky homology of L , and for $i > 0$ the abelian groups are zero.

The Khovanov–Rozansky 4-categories can be fed into the general machinery of [Wal, MW12] to produce fully extended $4+\epsilon$ -dimensional TQFTs. One consequence of this is that the invariants \mathcal{S}_*^N satisfy a gluing formula [MW12, Theorem 7.2.1] expressed in terms of a tensor product over a category associated to the gluing locus. In particular, we expect that $\mathcal{S}_*^N(B^3 \times S^1; \{2n \text{ points}\} \times S^1)$ is related to the Hochschild homology of the \mathfrak{gl}_N analog of Khovanov’s arc algebra. For applications of the latter to link homology see Rozansky [Roz10] and Willis [Wil21] ($N = 2$) and Gorsky–Hogancamp–Wedrich [GHW21] ($N = \infty$).

¹These are related, but not identical, to categories of higher representations of *categorified* quantum \mathfrak{gl}_N .

We would like to emphasize that \mathcal{S}_*^N should be thought of as a categorified analog of the $3+\epsilon$ -dimensional skein module TQFTs, see Walker [Wal], or the 3-dimensional layers of Crane–Yetter–Kauffman TQFTs [CKY97] at generic q , but not the 2+1-dimensional Witten–Reshetikhin–Turaev TQFTs [Wit89, RT91].

Precise relationships along these lines and calculations based on the gluing formula appear in later papers [MN20, MWW2, HRW3].

Homotopy coherence. Current constructions of Khovanov–Rozansky link homologies proceed via a functorial invariant of tangles and tangle cobordisms up to isotopy, taking values in the bounded homotopy category of an additive category; see §2. Our proof of Theorem 1.1 is stronger than necessary in the sense that it shows that a certain equivalent reformulation of the sweep-around move holds on the chain level (i.e. not just up to homotopy) provided the tangle T is presented as a partial braid closure.

It is an open question whether the Khovanov–Rozansky homologies are truncations of homotopy-coherent versions with values in chain complexes over the same additive category. If this is indeed the case, then it is plausible that our method of proof would be suitable for an analog of Theorem 1.1 in this setting. Given a fully homotopy-coherent invariant of links in S^3 , we could construct a disklike 4-category enriched in chain complexes (rather than abelian groups), and then use a homotopy colimit construction to extend this invariant to 4-manifolds [MW12, §7]. The result would be a well-defined-up-to-coherent-homotopy chain complex assigned to a 4-manifold W and a boundary condition L . At the end of this process we could take homology of this chain complex to produce an abelian group. The invariants $\mathcal{S}_*^N(W; L)$ can be thought of as an approximation to the latter, given by taking homology (too) early in the construction. One would then expect the two theories to be related by a spectral sequence.

Genus bounds. The results here hold for the ordinary Khovanov–Rozansky \mathfrak{gl}_N link homologies as well as for their $\mathrm{GL}(N)$ -equivariant and deformed versions [Lee05, Kho06, BNM06, Wu12, ETW18]. In the case of links in $S^3 = \partial B^4$, the passage from the ordinary to deformed settings gives rise to spectral sequences that were studied in [Gor04, Ras15, Wu09, RW16]. Lobb and Wu [Lob09, Wu09], following pioneering work of Rasmussen [Ras10], showed that the associated filtrations for the generically deformed knot homologies in $S^3 = \partial B^4$ contain lower bounds on the slice genus, i.e. the minimal genus of smooth surfaces in B^4 bounding the knot. Using such invariants, Freedman–Gompf–Morrison–Walker have outlined a strategy for testing counterexamples to the smooth 4-dimensional Poincaré conjecture [FGMW10]. One motivation for studying 4-manifold invariants from Khovanov–Rozansky homologies is that analogous spectral sequences might give rise to lower bounds on the genera of smooth surfaces in 4-manifolds W^4 bounding knots in $M^3 = \partial W^4$.

Relations to other work. There have been several proposed approaches to constructing homology theories for links in 3-manifolds, or 4-manifold invariants, which either intended to categorify \mathfrak{sl}_2 or \mathfrak{gl}_N quantum invariants or to directly generalize Khovanov–Rozansky homology. These include

- (1) categorifying Witten–Reshetikhin–Turaev invariants at roots of unity, see e.g. Khovanov [Kho16], Qi [Qi14], Elias–Qi [EQ16] and Qi–Sussan [QS17],
- (2) using 2-representations of categorified quantum groups in the sense of Rouquier [Rou08] and Khovanov–Lauda [KL10] to construct a 4-category that can be integrated over 4-manifolds, see e.g. Webster [Web17] for categorified tensor products,
- (3) categorifying skein algebras and 3-manifold skein modules, see Asaeda–Przytycki–Sikora [APS04] Thurston [Thu14] and Queffelec–Wedrich [QW18a, QW21], starting from the thickened annulus, see Grigsby–Licata–Wehrli [GLW18], Beliakova–Putyra–Wehrli [BPW19] and Queffelec–Rose [QR18], or connect sums of $S^1 \times S^2$, see Rozansky [Roz10] and Willis [Wil21].

- (4) giving a mathematically rigorous construction of the BPS spectra (“relative Gromov–Witten invariants”) proposed by Gukov–Putrov–Vafa [GPV17] and Gukov–Pei–Putrov–Vafa [GPPV20] based on Gukov–Schwarz–Vafa [GSV05], see e.g. Gukov–Manolescu [GM21] and Ekholm–Shende [ES19],
- (5) extending Witten’s gauge-theoretic interpretation of Khovanov homology [Wit12] from \mathbb{R}^3 to other 3-manifolds, see also Taubes [Tau13, Tau18].

Comparing these approaches with the invariants defined here may be an interesting topic for further research. We expect a close relationship with approach (2) already at the level of 4-categories, and with approach (3) since it uses the same underlying combinatorics. The latter is especially appealing since (3) is, on the one hand, computationally well-developed for thickened surfaces, but, on the other hand, poses many open questions about the categorification of skein algebras and related quantum cluster algebras, onto which our invariants might shed new light.

While this article was under review, Manolescu–Neithalath [MN20] have shown that the values of \mathcal{S}_0^N on 2-handlebodies can be computed from the Khovanov–Rozansky homology of cables of attaching links. The procedure takes the form of evaluating the Khovanov–Rozansky homology of the attaching link colored by a *categorical Kirby color*, a structure developed in the prototypical case $N = 2$ by Hogancamp–Rose–Wedrich in [HRW3]. More generally, the values of \mathcal{S}_0^N can be computed for general 4-manifolds from a handle decomposition, see Manolescu–Walker–Wedrich [MWW2].

Acknowledgements. The authors would like to thank Ian Agol, Chris Douglas, Mike Freedman, Marco Mackaay, Anton Mellit, Stephen Morgan, and Hoel Queffelec for helpful conversations. Scott Morrison was partially supported by Australian Research Council grants ‘Low dimensional categories’ DP160103479 and ‘Quantum symmetries’ FT170100019. Paul Wedrich was supported by Australian Research Council grants ‘Braid groups and higher representation theory’ DP140103821 and ‘Low dimensional categories’ DP160103479.

2. TECHNOLOGY

The purpose of this section is to survey the technology used in functorial Khovanov–Rozansky link homologies and to set up notation.

2.1. Webs. The category $\text{Rep}(U_q(\mathfrak{gl}_N))$ of finite-dimensional $U_q(\mathfrak{gl}_N)$ -modules is a ribbon category and thus provides Reshetikhin–Turaev invariants of framed oriented tangles with components labeled by objects of $\text{Rep}(U_q(\mathfrak{gl}_N))$. A framed oriented link L labeled by the $U_q(\mathfrak{gl}_N)$ -module $V = \mathbb{C}^N(q)$ yields an endomorphism of $\mathbb{C}(q)$, the tensor unit in $\text{Rep}(U_q(\mathfrak{gl}_N))$, which is just multiplication by the \mathfrak{gl}_N link polynomial of L .

While we will focus on invariants of links labeled by V , it is convenient to also consider the fundamental modules $\wedge^k(V)$ and their duals. Together, these generate the full monoidal subcategory $\text{Fund}(U_q(\mathfrak{gl}_N))$, which admits a graphical presentation and which recovers $\text{Rep}(U_q(\mathfrak{gl}_N))$ upon idempotent completion.

The $\mathbb{C}(q)$ -linear pivotal category \mathbf{Web}_N has objects given by finite sets of points in an interval $[0, 1]$, each labeled by an element of $\{n, n^* \mid n \in \mathbb{Z}_{>0}\}$. The morphisms are $\mathbb{C}(q)$ -linear combinations of webs: oriented trivalent graphs, properly embedded in $[0, 1]^2$, with edges labeled by a non-negative integer flow, considered up to isotopy relative to the boundary and certain local relations, including those shown in (2.1). The source and target of a web are determined by its intersections with $[0, 1] \times \{0\}$ and $[0, 1] \times \{1\}$, with downward oriented boundary points of label n being recorded as n^* . Composition is given by the bilinear extension of stacking webs and the tensor product is given on objects by concatenating labeled intervals and on morphisms by the bilinear extension of placing webs side by side.

The morphisms in \mathbf{Web}_N are generated under composition, tensor product, and duality by identity morphisms and trivalent *merge* and *split* vertices:

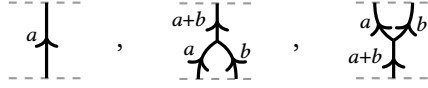

The merge and split vertices encode the natural $U_q(\mathfrak{gl}_N)$ -intertwiners

$$\wedge^a(V) \otimes \wedge^b(V) \rightarrow \wedge^{a+b}(V) \quad \text{and} \quad \wedge^{a+b}(V) \rightarrow \wedge^a(V) \otimes \wedge^b(V),$$

respectively. The local relations in \mathbf{Web}_N include

$$(2.1) \quad \begin{array}{c} \text{merge} \\ \text{split} \end{array} = \begin{bmatrix} a \\ b \end{bmatrix} \begin{array}{c} \text{split} \\ \text{merge} \end{array}, \quad \begin{array}{c} \text{merge} \\ \text{split} \end{array} = \begin{bmatrix} N-a \\ b \end{bmatrix} \begin{array}{c} \text{split} \\ \text{merge} \end{array}, \quad \begin{array}{c} \text{merge} \\ \text{split} \end{array} = \begin{array}{c} \text{merge} \\ \text{split} \end{array}, \quad \begin{array}{c} \text{merge} \\ \text{split} \end{array} = \sum_t \begin{bmatrix} k-l+r-s \\ t \end{bmatrix} \begin{array}{c} \text{merge} \\ \text{split} \end{array}$$

together with the reflections of these relations in a vertical line. Edges labeled zero are to be erased and edges labeled by negative integers or integers greater than N force the morphism to be the zero morphism. The local relations ensure that $\mathbf{Web}_N \cong \text{Fund}(U_q(\mathfrak{gl}_N))$ as $\mathbb{C}(q)$ -linear pivotal categories, see [CKM14, QS19, TVW17]. In the following, we also consider an integral version of \mathbf{Web}_N , which is defined over $\mathbb{Z}[q^{\pm 1}]$ and also satisfies the relations (2.1).

2.2. Foams. Foams provide a framework for a combinatorial description of Khovanov–Rozansky link homologies, in a similar way as webs are useful for the type A Reshetikhin–Turaev invariants. We will use \mathfrak{gl}_N -foams constructed via the combinatorial evaluation formula for closed foams due to Robert–Wagner [RW20]. More precisely, we will organize these \mathfrak{gl}_N -foams into a monoidal bicategory \mathbf{Foam}_N which categorifies the integral form of \mathbf{Web}_N .

The graded, additive monoidal bicategory \mathbf{Foam}_N has objects given by finite sets of points in $[0, 1]$, each labeled by an element of $\{n, n^* | n \in \mathbb{Z}_{>0}\}$. The 1-morphisms are (formal direct sums of formal grading shifts of) webs, properly embedded in $[0, 1]^2$ and connecting boundary points of appropriate labels. Note that webs are not considered up to any relations in \mathbf{Foam}_N . The 2-morphisms are (matrices of degree zero) \mathbb{Z} -linear combinations of \mathfrak{gl}_N -foams in $[0, 1]^3$, considered up to isotopy relative to the boundary and certain local relations, as defined in [ETW18, Section 2]. The three compositions are given by (the bilinear extension of) stacking these topological objects along the three interval directions.

Foams are the natural notion of cobordisms between webs and the relations between 2-morphisms in \mathbf{Foam}_N are chosen so that the defining *web equalities* in \mathbf{Web}_N can be lifted to explicit *web isomorphisms* in \mathbf{Foam}_N . We refer to [ETW18] for a rigorous definition of \mathfrak{gl}_N -foams, as well as a complete description of the relations between them, and a survey of various flavors of \mathbf{Foam}_N . Here we only comment on aspects relevant to the rest of this paper.

Foams are represented by 2-dimensional cell complexes, such that every point has a neighborhood either modelled on \mathbb{R}^2 , three half-planes meeting in a line, or the cone on the 1-skeleton of a tetrahedron. Such cone points are called *singular vertices* of the foam. The points on the line in the second case form a *seam* of the foam, and the connected components of the set of manifold points are called the *facets* of the foam. An example of a foam with six singular vertices is shown in Figure 1. The facets are oriented and labeled by positive integers. If three facets meet along a seam, then two of their labels, say a and b , sum to the third, $a + b$. The orientation of the seam agrees with the orientation induced by the a and b facets, and disagrees with the $a + b$ facet.

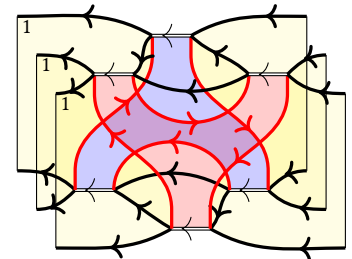

FIGURE 1.

together with an ordering of the finitely many crossings in the diagram. The morphisms are oriented link cobordisms in $\mathbb{R}^3 \times [0, 1]$ up to isotopy rel boundary, together with formal crossing reordering isomorphisms.

In one direction, by forgetting the condition on the projection and ignoring the crossing order, this category is equivalent to the usual category of all embedded, framed oriented links and link cobordisms. In the other direction, the category $\mathbb{R}^3\mathbf{Link}^\circ$ is equivalent to the category whose objects are link diagrams and whose morphisms are sequences of Reidemeister moves, Morse moves, planar isotopies, and formal reorderings, considered up to Carter–Rieger–Saito movie moves [CS93, CRS97].

We will now describe the construction of a functor $\llbracket - \rrbracket : \mathbb{R}^3\mathbf{Link}^\circ \rightarrow \mathbf{K}^b(\mathbf{Foam}_N)$, with target given by the bounded homotopy category of \mathbf{Foam}_N . In particular, the functor sends link diagrams to certain bounded chain complexes of webs and foams. On single, 1-labeled crossings, it is defined as:

$$(2.3) \quad \left[\begin{array}{c} \nearrow \\ \searrow \end{array} \right] = q \begin{array}{c} \nearrow \\ \searrow \end{array} \rightarrow \underbrace{\uparrow \uparrow}, \quad \left[\begin{array}{c} \searrow \\ \nearrow \end{array} \right] = \underbrace{\uparrow \uparrow} \rightarrow q^{-1} \begin{array}{c} \searrow \\ \nearrow \end{array}$$

The underlined term is placed in homological degree zero. We call the non-identity webs that appear here *thick edges*. The differentials in both complexes are given by the combinatorially simplest foam between the two shown webs. We call them *unzip* and *zip foams* respectively. The reader be warned that the assignments in (2.3) differ from the conventions in [KR08, Fig. 46] by a q -grading shift of magnitude $(N - 1)w$, where w denotes the writhe of the diagram; the latter further differ from the conventions in [ETW18, Equation (3.2)] by mirroring.

A link diagram with several crossings (in a specified order) is sent to the chain complex constructed from the formal tensor product of the crossing complexes (2.3) (in that order) by gluing its resolutions into the link diagram in place of the original crossings.

The chain complexes associated to link diagrams which differ only by Reidemeister moves are homotopy equivalent, see Sections 3.3–3.5. Similarly, one can define chain maps for Morse moves. However, a highly non-trivial fact is that there exists a coherent choice for such chain maps.

Theorem 2.4 ([ETW18]). *The construction $\llbracket - \rrbracket : \mathbb{R}^3\mathbf{Link}^\circ \rightarrow \mathbf{K}^b(\mathbf{Foam}_N)$ is functorial.*

In fact, Theorem 2.4 holds in much greater generality, including colored links and the equivariant framework mentioned in Remark 2.2. More importantly for us, the theorem holds locally, i.e. for tangle diagrams and tangle cobordisms.

Definition 2.5. The Khovanov–Rozansky \mathfrak{gl}_N link homology $\mathbf{KhR}_N : \mathbb{R}^3\mathbf{Link}^\circ \rightarrow \mathbf{gr}^{\mathbb{Z} \times \mathbb{Z}} \mathbf{AbGrp}$, with target given by the category of $\mathbb{Z} \times \mathbb{Z}$ -graded abelian groups and homogeneous homomorphisms, is defined as the composition of $\llbracket - \rrbracket$, the representable functor $\bigoplus_{k \in \mathbb{Z}} \mathbf{Foam}_N(q^{-k}\emptyset, -)$, and taking homology. It is functorial by Theorem 2.4.

3. THE SWEEP-AROUND MOVE

The purpose of this section is to prove Theorem 1.1.

3.1. Reduction to almost braid closures. Given a braid word β for a braid $[\beta] \in \mathbf{Br}_{n+1}$, we can get a 1-1-tangle diagram by taking the braid closure of the n rightmost strands. We say that such 1-1-tangle diagrams are in *almost braid closure form*. From a 1-1-tangle diagram T , one can obtain link diagrams L and L' by taking either the left- or right-handed closure of the single open strand. These diagrams are illustrated at the top left and top right of (3.1) respectively.

We note the following straightforward extension of the Alexander theorem.

Lemma 3.1. *Every 1-1-tangle can be isotoped into almost braid closure form.*

Proposition 3.2. *If the sweep-around map is homotopic to the identity for 1-1-tangles in almost braid closure form, then the same is true for all 1-1-tangle diagrams.*

Proof. Consider an isotopy that brings the tangle diagram T into almost braid closure form T' and denote its image under the Khovanov invariant as ϕ . Furthermore, let the maps associated to the sweep-around for T and T' be denoted by sw_T and $\text{sw}_{T'}$, respectively. Now, note that $\text{sw}_T \simeq \phi^{-1} \circ \text{sw}_{T'} \circ \phi$ because the underlying link cobordisms are isotopic in $\mathbb{R}^3 \times [0, 1]$. By assumption $\text{sw}_{T'} \simeq \text{id}_{T'}$ and thus also $\text{sw}_T \simeq \text{id}_T$. \square

3.2. The game plan. Fix an almost closure T of a braid word β for $[\beta] \in \text{Br}_{n+1}$. We call the right-hand closure L and the left-hand closure L' . We consider the following movies of intermediate diagrams and their associated chain maps between Khovanov–Rozansky complexes.

(3.1)

In the first row, the \pm signs indicate the two versions of this movie, in which the horizontal strand passes in front of (+) or behind (−) T . We denote the composition along the top by sw_+ and the composition along the bottom by sw_- . In either case we first see a Reidemeister I move (denoted by $R1_{\pm}$), then a composite of Reidemeister II moves (denoted by $R2_{\pm}$), a number of Reidemeister III moves (each denoted by $R3_{\pm}$), a composite of inverse Reidemeister II moves ($R2_{\pm}^{-1}$), and finally an inverse Reidemeister I move ($R1_{\pm}^{-1}$). Our goal is to show that, after making careful use of the freedom, described later, to choose up-to-homotopy representatives of the chain maps for Reidemeister III moves, we have the following:

Theorem 3.3. *For every almost braid closure diagram T , the front sweep sw_+ and the back sweep sw_- chain maps constructed above are identical (not just merely homotopic).*

Together with Proposition 3.2, this will imply Theorem 1.1.

Corollary 3.4. *For every almost braid closure diagram T , we have $\text{sw}_T = \mathbf{1}_T$.*

Proof. We have $\text{sw}_T = (\text{sw}_-)^{-1} \circ \text{sw}_+ = (\text{sw}_-)^{-1} \circ \text{sw}_- = \mathbf{1}_T$. \square

The proof of Theorem 3.3 will occupy the rest of this section.

We distinguish two types of crossings in the intermediate diagrams L_{\pm}^i . The crossings of the moving, horizontal, strand with everything else will be called *external*. The remaining crossings were already present in T and will be called *internal*.

Definition 3.5. The homological grading on $[[L_{\pm}^i]]$ splits into the sum of the *internal* and *external homological gradings*, contributed by resolutions of internal and external crossings respectively. The internal and external homological degrees of a web W appearing in $[[L_{\pm}^i]]$ will be denoted by $\text{gr}_{\text{int}}(W)$ and $\text{gr}_{\text{ext}}(W)$ respectively.

The braid word β determines an ordering of the crossings in T , L , and L' , namely *from top to bottom*. This ordering also induces an ordering of the internal crossings in all other diagrams in (3.1). The diagrams L_{\pm}^0 and L_{\pm}^x have one additional external crossing. The diagrams L_{\pm}^i for $1 \leq i \leq x-1$ all have $2n+1$ external crossings, which are ordered from right to left. We will classify webs W in each of these complexes according to the resolutions that appear at the crossings. For the following, let M denote the number of crossings in T , L , and L' .

Definition 3.6. The *type* of a web W in any of the complexes in (3.1) is the element $\tau(W) \in \{p, t\}^M$ that records in the j -th coordinate whether the j -th internal crossing in the respective link diagram is resolved in a parallel way (p), or using the thick edge (t).

The *offset* of a web W in any of the complexes $\llbracket L_{\pm}^i \rrbracket$ is the element $o(W) \in \{p, t\}$ that records the resolution of the leftmost external crossing.

The *state* of a web W in any of the complexes $\llbracket L_{\pm}^i \rrbracket$ for $1 \leq i \leq x-1$ is the element $s(W) \in \{p, t\}^{2n}$, which records the resolutions of the $2n$ rightmost external crossings (that is, all except the leftmost external crossing). Such a web W is said to be *palindromic* if $s(W)$ is a palindrome.

Remark. The webs W in the complexes $\llbracket L \rrbracket$ and $\llbracket L' \rrbracket$ are indexed by their types $\tau(W)$. The webs W in $\llbracket L_{\pm}^0 \rrbracket$, and $\llbracket L_{\pm}^x \rrbracket$ are indexed by the pairs $(\tau(W), o(W))$. The webs W in the complexes $\llbracket L_{\pm}^i \rrbracket$ for $1 \leq i \leq x-1$ are indexed by the triples $(\tau(W), o(W), s(W))$.

Definition 3.7. If $i \in \{0, 1, \dots, x\}$, $\epsilon \in \{+, -\}$, $s \in \{p, t\}^{2n}$, $o \in \{p, t\}$ and $\tau \in \{p, t\}^M$, we will use $W_{\epsilon}^i(\tau, o, s)$ or $W_{\epsilon}^i(\tau, o)$ to denote the web in $\llbracket L_{\epsilon}^i \rrbracket$ with indexing data (τ, o, s) or (τ, o) , as appropriate. Analogously, we write $W(\tau)$ and $W'(\tau)$ for τ -indexed webs in $\llbracket L \rrbracket$ and $\llbracket L' \rrbracket$ respectively. If the indexing data is fixed, we will sometimes omit it from the notation (e.g. $W_{\pm}^i = W_{\pm}^i(\tau, o, s)$ and $W = W(\tau)$) and say that the webs W_{+}^i and W_{-}^i *correspond* to each other.

If f is a chain map and V and W are webs in the source and target complexes, then we write $f(V, W)$ for the component of f from V to W .

Remark. Suppose $s \in \{p, t\}^{2n}$, $o \in \{p, t\}$ and $\tau \in \{p, t\}^M$. For $1 \leq i \leq x-1$ we have $W_{+}^i(\tau, o, s) = W_{-}^i(\tau, o, s)$ as webs, and for $i \in \{0, x\}$ we have $W_{+}^i(\tau, o) = W_{-}^i(\tau, o)$ as webs. Moreover, $\text{gr}_{\text{ext}}(W_{+}^i(\tau, p, s)) = -\text{gr}_{\text{ext}}(W_{-}^i(\tau, p, s))$.

3.3. Reidemeister I moves. The Reidemeister I chain maps are the following.

$$\begin{array}{cccc}
\begin{array}{c} \llbracket \uparrow \downarrow \rrbracket \\ R1_{+} \updownarrow \\ \llbracket \uparrow \uparrow \rrbracket \end{array} & \begin{array}{c} \curvearrowright \rightarrow \curvearrowleft \\ \text{cup} \updownarrow \text{dcap} \end{array} & \begin{array}{c} \llbracket \uparrow \downarrow \rrbracket \\ R1_{-} \updownarrow \text{dcup} \updownarrow \text{cap} \\ \llbracket \uparrow \uparrow \rrbracket \end{array} & \begin{array}{c} \llbracket \uparrow \downarrow \rrbracket \\ R1_{+}^{-1} \updownarrow \text{dcap} \updownarrow \text{cup} \\ \llbracket \uparrow \uparrow \rrbracket \end{array} & \begin{array}{c} \llbracket \uparrow \downarrow \rrbracket \\ R1_{-}^{-1} \updownarrow \text{cap} \updownarrow \text{dcup} \\ \llbracket \uparrow \uparrow \rrbracket \end{array} \\
\begin{array}{c} \uparrow \\ \uparrow \end{array} & \begin{array}{c} \uparrow \\ \uparrow \end{array} & \begin{array}{c} \uparrow \\ \uparrow \end{array} & \begin{array}{c} \uparrow \\ \uparrow \end{array} & \begin{array}{c} \uparrow \\ \uparrow \end{array}
\end{array}$$

Here cap and cup simply denote the cap and cup foams, while dcap and dcup denote decorated cap and cup foams. The decoration is by the polynomial $\sum_{a+b=N-1} X^a Y^b$ where X denotes the dot on the strand and Y the dot on the circle; see (2.2). We have only assigned notation $R1_{\pm}$ and $R1_{\pm}^{-1}$ to those Reidemeister I chain maps that are relevant for the sweep-around move.

Lemma 3.8. *The Reidemeister I chain maps $R1_{\pm}: \llbracket L \rrbracket \rightarrow \llbracket L_{\pm}^0 \rrbracket$ and $R1_{\pm}^{-1}: \llbracket L_{\pm}^x \rrbracket \rightarrow \llbracket L' \rrbracket$ preserve the internal and external homological degrees individually. Moreover, their only non-zero components are in external homological grading zero.*

Proof. This is immediate from the explicit description of these chain maps. \square

Lemma 3.9. *In external homological grading zero, we have $R1_- = p \circ R1_+$ and $R1_+^{-1} = R1_-^{-1} \circ p'$ where p and p' are chain maps of decorated identity foams such that*

$$R2_-^{-1} \circ R3_- \circ \dots \circ R3_- \circ R2_- \circ p = p' \circ R2_-^{-1} \circ R3_- \circ \dots \circ R3_- \circ R2_-$$

Proof. The chain maps p and p' each consist of identity foams decorated by the polynomial $\sum_{a+b=N-1} X^a Y^b$. In p , the dots X and Y are placed next to the Reidemeister I crossing, as shown in the first picture on the right. These dots are spatially separated from the region in which the $R2$ and $R3$ moves are taking place, so we can slide them spatially lower in the diagram, and timewise past all the $R2$ and $R3$ moves. At that point, shown in the second diagram on the right, the dots are in exactly the positions to give p' . \square

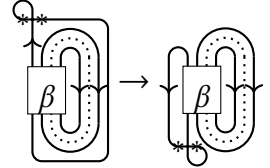

3.4. Reidemeister II moves. We will use Elias–Khovanov’s Soergel calculus [EK10a] to describe the chain maps associated to Reidemeister II and III moves. The Soergel calculus of type A_{n-1} is a graphical incarnation of the 2-category of Soergel bimodules, which categorifies the Hecke algebra for S_n . For any $N \geq 2$, it admits a 2-functor to the monoidal subcategory of \mathbf{Foam}_N of webs and foams with $2n$ boundary components with suitable orientations, see e.g. [MV10]. Instead of describing these 2-functors formally, we will just use the Soergel calculus as *shorthand* notation for foams using the following dictionary:

- In the A_1 calculus, we have only a blue object, which we will interpret as the two strand web

$$\color{blue}{|} \mapsto \color{blue}{\begin{array}{c} \diagup \\ \diagdown \end{array}}$$

- In the A_2 calculus, we have red and blue objects, interpreted as three strand webs

$$\color{blue}{|} \mapsto \color{blue}{\begin{array}{c} \uparrow \\ \diagdown \\ \diagup \end{array}}, \quad \color{red}{|} \mapsto \color{red}{\begin{array}{c} \diagup \\ \diagdown \\ \uparrow \end{array}}$$

- Start dots $\color{blue}{\downarrow}$ and end dots $\color{blue}{\uparrow}$ (in any color) correspond to zip and unzip foams.
- The trivalent vertices $\color{blue}{\begin{array}{c} \diagup \\ \diagdown \\ \color{blue}{\uparrow} \end{array}}$ and $\color{blue}{\begin{array}{c} \color{blue}{\downarrow} \\ \diagup \\ \diagdown \end{array}}$ correspond to digon creation and annihilation foams respectively. We also use cups $\color{blue}{\cup} := \color{blue}{\begin{array}{c} \diagup \\ \diagdown \\ \color{blue}{\downarrow} \end{array}}$ and caps $\color{blue}{\cap} := \color{blue}{\begin{array}{c} \color{blue}{\uparrow} \\ \diagup \\ \diagdown \end{array}}$.
- The 6-valent vertex $\color{red}{\times}$ corresponds to the foam shown in Figure 1.

The Reidemeister II chain maps are the following.

$$(3.2) \quad \begin{array}{c} \color{blue}{\begin{array}{c} \diagup \\ \diagdown \end{array}} \\ \color{blue}{\updownarrow} \\ \color{blue}{\begin{array}{c} \uparrow \\ \uparrow \\ \uparrow \end{array}} \end{array} \quad \begin{array}{c} \color{blue}{\downarrow} \color{blue}{\uparrow} \\ \color{blue}{\diagdown} \color{blue}{\diagup} \\ \color{blue}{\downarrow} \color{blue}{\uparrow} \\ \color{blue}{\downarrow} \color{blue}{\uparrow} \\ \color{blue}{\downarrow} \color{blue}{\uparrow} \end{array} \quad \begin{array}{c} \color{blue}{\downarrow} \color{blue}{\uparrow} \\ \color{blue}{\downarrow} \color{blue}{\uparrow} \\ \color{blue}{\downarrow} \color{blue}{\uparrow} \\ \color{blue}{\downarrow} \color{blue}{\uparrow} \\ \color{blue}{\downarrow} \color{blue}{\uparrow} \end{array} \quad \begin{array}{c} \color{blue}{\begin{array}{c} \diagup \\ \diagdown \end{array}} \\ \color{blue}{\updownarrow} \\ \color{blue}{\begin{array}{c} \uparrow \\ \uparrow \\ \uparrow \end{array}} \end{array} \quad \begin{array}{c} \color{blue}{\downarrow} \color{blue}{\uparrow} \\ \color{blue}{\diagdown} \color{blue}{\diagup} \\ \color{blue}{\downarrow} \color{blue}{\uparrow} \\ \color{blue}{\downarrow} \color{blue}{\uparrow} \\ \color{blue}{\downarrow} \color{blue}{\uparrow} \end{array} \quad \begin{array}{c} \color{blue}{\downarrow} \color{blue}{\uparrow} \\ \color{blue}{\downarrow} \color{blue}{\uparrow} \\ \color{blue}{\downarrow} \color{blue}{\uparrow} \\ \color{blue}{\downarrow} \color{blue}{\uparrow} \\ \color{blue}{\downarrow} \color{blue}{\uparrow} \end{array}$$

In both cases we have chosen to order the crossings from the top to the bottom. Now we can record two observations concerning the composite (inverse) Reidemeister II chain maps $R2_{\pm}$ and $R2_{\pm}^{-1}$.

Lemma 3.10. *The chain maps $R2_{\pm}: \llbracket L_{\pm}^0 \rrbracket \rightarrow \llbracket L_{\pm}^1 \rrbracket$ and $R2_{\pm}^{-1}: \llbracket L_{\pm}^{x-1} \rrbracket \rightarrow \llbracket L_{\pm}^x \rrbracket$ preserve the internal and external homological gradings individually and their only non-zero components involve palindromic resolutions.*

Lemma 3.11. Let $W_{\pm}^0 = W_{\pm}^0(\tau, o)$ and $W_{\pm}^x = W_{\pm}^x(\tau, o)$ be pairs of corresponding webs in $\llbracket L_{\pm}^0 \rrbracket$ and $\llbracket L_{\pm}^x \rrbracket$ respectively. Further, let $s \in \{p, t\}^{2n}$ be a palindrome in which t appears $2k$ times, and consider $W_{\pm}^1 = W_{\pm}^1(\tau, o, s)$ and $W_{\pm}^{x-1} = W_{\pm}^{x-1}(\tau, o, s)$ in $\llbracket L_{\pm}^1 \rrbracket$ and $\llbracket L_{\pm}^{x-1} \rrbracket$ respectively. Then

$$R2_{-}(W_{-}^0, W_{-}^1) = (-1)^k R2_{+}(W_{+}^0, W_{+}^1)$$

$$R2_{+}^{-1}(W_{+}^{x-1}, W_{+}^x) = (-1)^k R2_{-}^{-1}(W_{-}^{x-1}, W_{-}^x).$$

Proof. In a single Reidemeister II move, the identity resolution is always sent to the identity resolution via the identity. The maps involving the resolution with two thick edges are negatives of each other, when comparing the two types of Reidemeister II moves with fixed order of crossings as in (3.2). \square

3.5. Reidemeister III moves. In (3.1) we encounter four types of Reidemeister III moves. Namely, the *moving strand* can pass in front of or behind a positive or a negative crossing. In the following we show the front and back versions alongside each other. In every case, the moving strand is the one connecting the bottom left and top right boundary points.

In each variant of Reidemeister III, we order the crossings in each tangle from top to bottom. The parts of the complexes with internal homological degree zero—where the internal crossing is resolved in the parallel fashion—are highlighted in blue. The parts with internal homological degree ± 1 are highlighted in yellow.

There is a 2-dimensional space of chain maps between the two sides of each Reidemeister III move [EK10b]. There is a 1-dimensional affine subspace of these chain maps which, given the previous choices for Reidemeister I and II maps, provides a functorial link invariant, by Theorem 2.4. (Note that their proof does not rely on any particular choice of chain maps from this subspace; any will do!) This subspace is characterised by the condition that the component of the chain map between parallel resolutions is the identity (this condition corresponds to the appearance of a blue highlighted 1 in each chain map below). In the diagrams below, we parametrise this subspace by a variable y ; shortly we shall specialize to $y = 0$.

All choices of chain map in this affine subspace are homotopic, so for many purposes this structure can be ignored. For the present proof, however, it is quite important that we make the most convenient choice of up-to-homotopy representative.

When the moving strand passes a positive crossing we have:

(3.3)

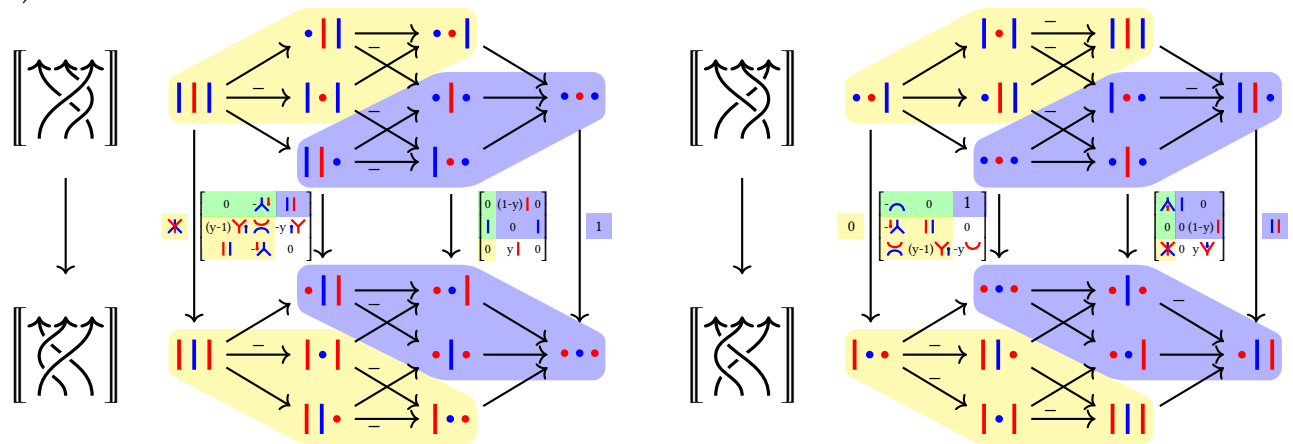

Next, we consider the two ways in which the moving strand may pass a negative crossing:

(3.4)

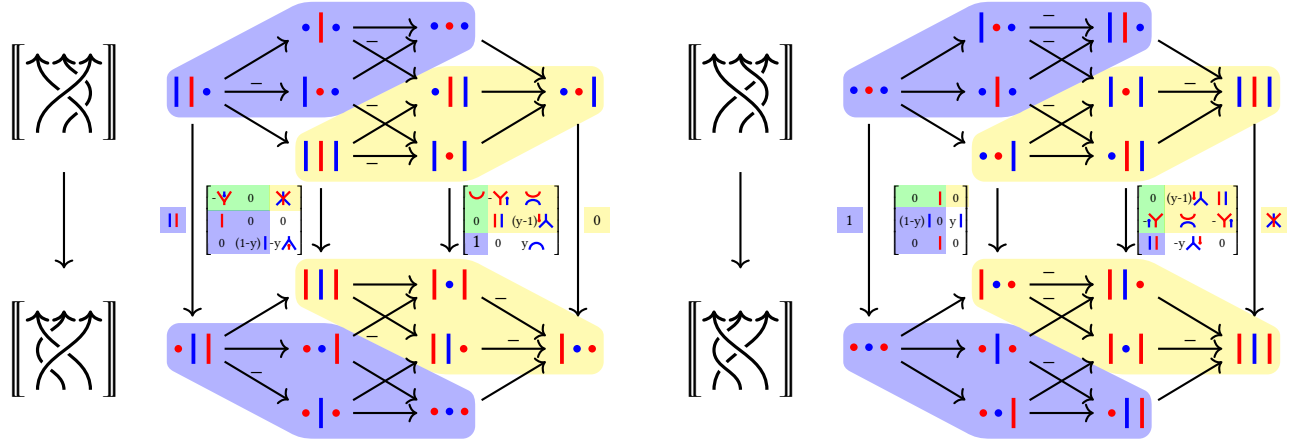

For the remainder of this paper we specialise to the choice $y = 0$. (Note in particular that the statements immediately below are not true for other choices!)

Lemma 3.12. *The chain maps $R3_{\pm}: \llbracket L_{\pm}^i \rrbracket \rightarrow \llbracket L_{\pm}^{i+1} \rrbracket$ in (3.1) do not decrease the external homological grading.*

Proof. Since chain maps are of homological degree zero, the statement is equivalent to saying that the Reidemeister III chain maps in (3.1) never *increase* the *internal* homological grading. This can be verified by inspecting (3.3) and (3.4). For the reader's convenience we have highlighted the components of negative internal homological degree in green. All other non-zero components are highlighted blue or yellow and have internal homological degree zero because they map between the yellow and blue layers of the relevant complexes. Thus we only need to worry about components of the chain map which are *not* highlighted in the diagrams above. With $y = 0$, these components all vanish. \square

In other words, the Reidemeister III maps are filtered with respect to the filtration determined by the internal homological degree, which we shall call the *internal filtration*.

Proposition 3.13. *The filtration-preserving components of the chain maps*

$$R3_+: \llbracket L_+^i \rrbracket \rightarrow \llbracket L_+^{i+1} \rrbracket \quad \text{and} \quad R3_-: \llbracket L_-^i \rrbracket \rightarrow \llbracket L_-^{i+1} \rrbracket$$

agree if $1 \leq i < x - 1$. More precisely, we have

$$R3_+(W_+, W_+^{i+1}) = R3_-(W_-, W_-^{i+1})$$

for pairs of corresponding webs W_{\pm}^i in $\llbracket L_{\pm}^i \rrbracket$ and W_{\pm}^{i+1} in $\llbracket L_{\pm}^{i+1} \rrbracket$ with $\text{gr}_{\text{ext}}(W_{\pm}^i) = \text{gr}_{\text{ext}}(W_{\pm}^{i+1})$.

Proof. By inspecting (3.3) and (3.4) — for each of the 1+9+9+1 components of the $R3_+$ chain map, check that the corresponding component of the $R3_-$ chain map is the same (recalling $y = 0$). \square

Corollary 3.14. *The filtration-preserving component of the chain maps*

$$R3_+ \circ \cdots \circ R3_+: \llbracket L_+^1 \rrbracket \rightarrow \llbracket L_+^{x-1} \rrbracket \quad \text{and} \quad R3_- \circ \cdots \circ R3_-: \llbracket L_-^1 \rrbracket \rightarrow \llbracket L_-^{x-1} \rrbracket$$

agree. More precisely, we have

$$R3_+(W_+, W_+^{x-1}) = R3_-(W_-, W_-^{x-1})$$

for pairs of corresponding webs W_{\pm}^1 in $\llbracket L_{\pm}^1 \rrbracket$ and W_{\pm}^{x-1} in $\llbracket L_{\pm}^{x-1} \rrbracket$ with $\text{gr}_{\text{ext}}(W_{\pm}^1) = \text{gr}_{\text{ext}}(W_{\pm}^{x-1})$.

Remark. The Reidemeister III chain maps shown in (3.3) and (3.4), their inverses, and four additional variations were studied by Elias–Krasner [EK10b]. Note, however, the following differences in conventions. Their positive crossings are our negative crossings and the crossings in their braids are ordered from bottom to top, while we order them from top to bottom. Finally, they read Soergel diagrams from left to right, while we read them from right to left.

3.6. Proof of the sweep-around property.

Proof of Theorem 3.3. We need to show that the two chain maps sw_+ and sw_- from (3.1) are equal. For this, let W and W' be webs in $\llbracket L \rrbracket$ and $\llbracket L' \rrbracket$ respectively. We shall compare the components of sw_+ and sw_- between W and W' .

By Proposition 3.13, the $R3_{\pm}$ maps do not decrease the external homological degree, but by Lemmas 3.8 and 3.10, the $R1_{\pm}^{\pm 1}$ and $R2_{\pm}^{\pm 1}$ maps preserve the external homological degree. Since $\text{gr}_{\text{ext}}(W) = \text{gr}_{\text{ext}}(W') = 0$, the increasing components of $R3_{\pm}$ do not contribute to sw_+ or sw_- . Now suppose that W_{\pm}^1 are corresponding webs in $\llbracket L_{\pm}^1 \rrbracket$ and W_{\pm}^{x-1} are corresponding webs in $\llbracket L_{\pm}^{x-1} \rrbracket$ with $\text{gr}_{\text{ext}}(W_{\pm}^1) = \text{gr}_{\text{ext}}(W_{\pm}^{x-1}) = 0$. Then, by Corollary 3.14,

$$(R3_+ \circ \cdots \circ R3_+)(W_+^1, W_+^{x-1}) = (R3_- \circ \cdots \circ R3_-)(W_-^1, W_-^{x-1}).$$

Let us also record that if $R3_{\pm} \circ \cdots \circ R3_{\pm}$ has a non-zero component between two webs W^1 and W^{x-1} , then first n digits of $t(W^1)$ agree with the first n digits of $t(W^{x-1})$. (Recall that the first n digits describe the rightmost n crossings, which are spatially separated from the region in which Reidemeister III moves occur.)

Next we consider the pair of corresponding webs $W_{\pm}^0 = W_{\pm}^0(s(W), p)$ in $\llbracket L_{\pm}^0 \rrbracket$, which appear in the image of W under $R1_{\pm}$, and the pair of corresponding webs $W_{\pm}^x = W_{\pm}^x(s(W'), p)$ in $\llbracket L_{\pm}^x \rrbracket$, which have W' as image under $R1_{\pm}^{-1}$. The components of $R2_{\pm}^{-1} \circ R3_{\pm} \circ \cdots \circ R3_{\pm} \circ R2_{\pm}$ between these webs are sums over components through many possible intermediate webs W_{\pm}^1 and W_{\pm}^{x-1} . By the previous argument, the Reidemeister III portions of the $+-$ and the $--$ -version of the map agree. By Lemma 3.11, the Reidemeister II portions could at most cause a sign-discrepancy. However, since the first n digits of $t(W_{\pm}^1), t(W_{\pm}^2), \dots, t(W_{\pm}^{x-1})$ all agree, and since Reidemeister II chain maps are zero on non-palindromic webs by Lemma 3.10, there is no sign-discrepancy. Thus, we record:

$$(R2_+^{-1} \circ R3_+ \circ \cdots \circ R3_+ \circ R2_+)(W_+^0, W_+^x) = (R2_-^{-1} \circ R3_- \circ \cdots \circ R3_- \circ R2_-)(W_-^0, W_-^x)$$

Finally, we use Lemma 3.9 to compute:

$$\begin{aligned} \text{sw}_-(W, W') &= (R1_-^{-1} \circ R2_-^{-1} \circ R3_- \circ \cdots \circ R3_- \circ R2_- \circ R1_-)(W, W') \\ &= (R1_-^{-1} \circ R2_-^{-1} \circ R3_- \circ \cdots \circ R3_- \circ R2_- \circ p \circ R1_+)(W, W') \\ &= (R1_-^{-1} \circ p' \circ R2_-^{-1} \circ R3_- \circ \cdots \circ R3_- \circ R2_- \circ R1_+)(W, W') \\ &= (R1_+^{-1} \circ R2_-^{-1} \circ R3_- \circ \cdots \circ R3_- \circ R2_- \circ R1_+)(W, W') \\ &= (R1_+^{-1} \circ R2_+^{-1} \circ R3_+ \circ \cdots \circ R3_+ \circ R2_+ \circ R1_+)(W, W') \\ &= \text{sw}_+(W, W') \end{aligned} \quad \square$$

4. KHOVANOV–ROZANSKY HOMOLOGY IN S^3

From now on, we will only consider framed oriented links and framed oriented link cobordisms. Furthermore, all diffeomorphisms are oriented.

4.1. Link homology in abstract 3-balls. The purpose of this section is to define a functorial Khovanov–Rozansky link homology for links in abstract 3-manifolds (abstractly) diffeomorphic to \mathbb{R}^3 , which is functorial under link cobordisms in abstract 4-manifolds diffeomorphic to $\mathbb{R}^3 \times [0, 1]$. The framework set up in this section could have been developed immediately after the initial construction of functorial link invariants, but to our knowledge it has not been developed in the literature. We hope that the careful presentation of this improvement of the invariant will be a helpful warm-up for the following section, where we employ a very similar strategy to build invariants of links in abstract 3-spheres.

$$\left\{ \begin{array}{l} \text{link embeddings in oriented } B \cong \mathbb{R}^3 \\ \text{link cobordisms in } \text{or.}W \cong \mathbb{R}^3 \times [0, 1] \text{ up to isotopy rel } \partial \end{array} \right\} \xrightarrow{\text{KhR}_N} \left\{ \begin{array}{l} \text{bigraded abelian groups} \\ \text{homogeneous homomorphisms} \end{array} \right\}$$

We will call such an invariant a *link homology for links in 3-balls*.

Throughout this section, B will denote a *3-ball*: an oriented 3-manifold that is diffeomorphic to \mathbb{R}^3 via some (unspecified!) diffeomorphism. We say a link embedding L in \mathbb{R}^3 is *generic* if it is in generic position with respect to the projection along the z -axis to \mathbb{R}^2 and all crossings in the resulting link diagram have distinct y coordinates. In this case, we consider the crossings as ordered from smallest to largest y coordinate. We say a link embedding L in \mathbb{R}^3 is *blackboard-framed* if the framing is parallel to \mathbb{R}^2 .

Lemma 4.1. *Let $L \subset B$ be a link embedded in a 3-ball. Let ϕ_0 and ϕ_1 be two diffeomorphisms from B to \mathbb{R}^3 such that $\phi_0(L)$ and $\phi_1(L)$ are generic. Then we have the following:*

- (1) *There exists a continuous family of diffeomorphisms ϕ_t for $t \in [0, 1]$, such that $\phi_t(L)$ is generic for all but finitely many $t \in [0, 1]$, at which a Reidemeister move occurs or the crossing height order changes.*
- (2) *Given two such families $\phi_{t,0}$ and $\phi_{t,1}$, both interpolating between ϕ_0 and ϕ_1 , then there exists a continuous family $\phi_{t,s}$ of diffeomorphisms interpolating between the families $\phi_{t,0}$ and $\phi_{t,1}$, for which the parameter space $[0, 1] \times [0, 1]$ is stratified such that:*
 - $\phi_{t,s}(L)$ is generic for (t, s) in any codimension-0 stratum,
 - $\phi_{t,s}(L)$ undergoes a Reidemeister move or the crossing height order changes as (t, s) crosses through a codimension-1 stratum,
 - $\phi_{t,s}(L)$ has a movie move as monodromy if (t, s) loops around a codimension-2 stratum.

Proof. These facts follow from [CS93, CRS97]. □

Definition 4.2. Let B be an oriented 3-manifold diffeomorphic to \mathbb{R}^3 . We define

$$M(B) \stackrel{\text{def}}{=} \{\text{diffeomorphisms } \phi: B \rightarrow \mathbb{R}^3\}.$$

Given an embedded link $L \subset B$, we define the subspace

$$M(B, L) \stackrel{\text{def}}{=} \{\phi \in M(B) \mid \phi(L) \text{ is } z\text{-generic and blackboard-framed}\},$$

and consider the bundle $\pi: T(B, L) \rightarrow M(B, L)$ of bigraded abelian groups, whose fiber at the point ϕ is $\text{KhR}_N(\phi(L))$.

For a path ϕ_t in $M(B)$ between points $\phi_0, \phi_1 \in M(B, L) \subset M(B)$, we define the grading-preserving isomorphism

$$(\text{KhR}_N(\phi_t): T(B, L)_{\phi_0} \rightarrow T(B, L)_{\phi_1}) \stackrel{\text{def}}{=} (\text{KhR}_N(\phi_t(L)): \text{KhR}_N(\phi_0(L)) \rightarrow \text{KhR}_N(\phi_1(L))),$$

where the latter denotes the homomorphism associated to the trace of the link isotopy $\phi_t(L)$ in $\mathbb{R}^3 \times [0, 1]$. This is well-defined by Theorem 2.4, even though for some t the embeddings $\phi_t(L)$ can be highly non-generic with respect to projection in the z -coordinate. Also note that while Reidemeister I moves induce

q -grading shifts on the level of KhR_N , any isotopy of framed links features such moves in pairs, leading to a grading-preserving isomorphism.

Lemma 4.3. *The parallel transport isomorphisms $\text{KhR}_N(\phi_t)$ define a flat connection on $T(B, L)$.*

Proof. Lemma 4.1 (1) implies that we have such parallel transport maps $\text{KhR}_N(\phi_t)$ between the fibers over any pair of points ϕ_0 and ϕ_1 in the base. Note that $\pi_1(M(B), \phi_0) \cong \pi_1(SO(3)) \cong \mathbb{Z}/2\mathbb{Z}$ is generated by the class of the loop obtained from ϕ_0 by rotating through 360 degrees around the z -axis, to which KhR_N assigns the identity map, see also Section 6.4. Lemma 4.1 (2) and Theorem 2.4 thus imply that the parallel transport maps between the fibers do not depend on the choice of the path ϕ_t . \square

Definition 4.4. Let $L \subset B$ be a link embedded in a 3-ball. Then we define the Khovanov–Rozansky homology of L in B to be

$$\text{KhR}_N(B, L) \stackrel{\text{def}}{=} \Gamma_{\text{flat}}(T(B, L)),$$

the bigraded abelian group of flat sections of the bundle $T(B, L)$.

Note that every diffeomorphism $\phi: B \rightarrow \mathbb{R}^3$ such that $\phi(L)$ is generic and blackboard-framed induces a grading-preserving isomorphism $\text{KhR}_N(B, L) \rightarrow \text{KhR}_N(\phi(L))$ by evaluating sections at the point ϕ .

Remark. An alternative way to describe this definition is as follows. Consider the groupoid with set of objects given by $M(B, L)$ and with morphisms given by paths ϕ_t modulo isotopies $\phi_{t,s}$ as in Lemma 4.1. Then KhR_N restricts to a functor from this groupoid to bigraded abelian groups and $\text{KhR}_N(B, L)$ is defined as its (co)limit.

Definition 4.5. Consider a link cobordism $\Sigma \subset W$ in a 4-manifold W diffeomorphic to $\mathbb{R}^3 \times [0, 1]$. Let $\Sigma_{\text{in}} \subset W_{\text{in}}$ and $\Sigma_{\text{out}} \subset W_{\text{out}}$ denote the boundary links in the incoming and outgoing boundary 3-balls of W . Then we define

$$\text{KhR}_N(W, \Sigma): \text{KhR}_N(W_{\text{in}}, \Sigma_{\text{in}}) \rightarrow \text{KhR}_N(W_{\text{out}}, \Sigma_{\text{out}})$$

in two steps. First we pick a diffeomorphism $\phi: W \rightarrow \mathbb{R}^3 \times [0, 1]$, such that $\phi_{\text{out}} := \phi|_{W_{\text{out}}}: W_{\text{out}} \rightarrow \mathbb{R}^3$ and $\phi_{\text{in}} := \phi|_{W_{\text{in}}}: W_{\text{in}} \rightarrow \mathbb{R}^3$ are such that $\phi_{\text{in}}(\Sigma_{\text{in}})$ and $\phi_{\text{out}}(\Sigma_{\text{out}})$ are both generic and blackboard-framed. Then we declare $\text{KhR}_N(W, \Sigma)(\eta)$, for a flat section $\eta \in \text{KhR}_N(W_{\text{in}}, \Sigma_{\text{in}})$, to be the unique flat section of $\text{KhR}_N(W_{\text{out}}, \Sigma_{\text{out}})$ with value:

$$\text{KhR}_N(W, \Sigma)(\eta)(\phi_{\text{out}}) = \text{KhR}_N(\phi(\Sigma))(\eta(\phi_{\text{in}}))$$

Lemma 4.6. *$\text{KhR}_N(W, \Sigma)$ is independent of the choices of ϕ_{in} , ϕ_{out} and ϕ , and thus well-defined.*

Proof. We first show independence of ϕ , given a fixed choice of ϕ_{in} and ϕ_{out} . Suppose that $\phi': W \rightarrow \mathbb{R}^3 \times [0, 1]$ is another diffeomorphism restricting to ϕ_{in} and ϕ_{out} on W_{in} and W_{out} respectively.

Lemma 4.7, proved below, implies that the link cobordisms $\phi(\Sigma)$ and $\phi'(\Sigma)$ are isotopic rel boundary in $\mathbb{R}^3 \times [0, 1]$ and we have $\text{KhR}_N(\phi(\Sigma)) = \text{KhR}_N(\phi'(\Sigma))$ by Theorem 2.4.

Next we show independence of ϕ_{in} , given a fixed choice of ϕ_{out} . Let $\phi'_{\text{in}}: W_{\text{in}} \rightarrow \mathbb{R}^3$ be another diffeomorphism such that $\phi'_{\text{in}}(\Sigma_{\text{in}})$ is generic and blackboard-framed, and ϕ' another diffeomorphism $W \rightarrow \mathbb{R}^3 \times [0, 1]$ restricting to ϕ'_{in} on W_{in} but still to ϕ_{out} on W_{out} . Then, by Lemma 4.1 (1), we can find a family $\phi_{\text{in},t}$ connecting ϕ_{in} to ϕ'_{in} . By definition of parallel transport, we have:

$$\eta(\phi'_{\text{in}}) = \text{KhR}_N(\phi_{\text{in},t}(\Sigma_{\text{in}}))(\eta(\phi_{\text{in}}))$$

Now we obtain a new diffeomorphism $\phi' \circ \phi_{\text{in},t}: W \rightarrow \mathbb{R}^3 \times [0, 1]$ and by the previous independence result and Theorem 2.4, we have:

$$\text{KhR}_N(\phi'(\Sigma))(\eta(\phi'_{\text{in}})) = \text{KhR}_N(\phi'(\Sigma) \circ \phi_{\text{in},t}(\Sigma_{\text{in}}))(\eta(\phi_{\text{in}})) = \text{KhR}_N(\phi(\Sigma))(\eta(\phi_{\text{in}}))$$

Thus, the definition was independent of the choice of ϕ_{in} . An analogous argument also establishes independence of the choice of ϕ_{out} . \square

It remains to prove the lemma referenced above.

Lemma 4.7. *Let $\Sigma \subset \mathbb{R}^3 \times [0, 1]$ be a link cobordism and let $f : \mathbb{R}^3 \times [0, 1] \rightarrow \mathbb{R}^3 \times [0, 1]$ be a diffeomorphism which restricts to the identity in a neighborhood of the boundary $\mathbb{R}^3 \times \{0, 1\}$. Then Σ is isotopic rel boundary to $f(\Sigma)$.*

Proof. The proof would be easy if we knew that f were isotopic to the identity, but $\pi_0(\text{Diff}^+(\mathbb{R}^3 \times [0, 1], \mathbb{R}^3 \times \{0, 1\}))$ is unknown. We can, however, replace f with a diffeomorphism f' which is isotopic (rel boundary) to f , or replace f with a diffeomorphism f' which coincides with f in a neighborhood of Σ . In both cases, proving that $f'(\Sigma)$ is isotopic to Σ easily implies that $f(\Sigma)$ is isotopic to Σ .

Choose a point $p \in \mathbb{R}^3$ such that $p \times [0, 1]$ is disjoint from Σ . There is no obstruction to modifying (post-composing) f by an isotopy which takes $f(p \times [0, 1])$ to $p \times [0, 1]$, so we may assume that f restricts to the identity on $p \times [0, 1]$. (Note that this modification changes $f(\Sigma)$ as well as $f(p \times [0, 1])$, so there is no issue of the image of $p \times [0, 1]$ getting “caught” on the image of Σ .)

Next consider the tangent map of f along $p \times [0, 1]$. We would like to deform the tangent map to the identity, but there is an obstruction living in $\pi_1(SO(3)) \cong \mathbb{Z}/2$. We can modify (precompose) f in a neighborhood of $p \times [0, 1]$ (and away from Σ) so that this obstruction vanishes. (Specifically, let $f : [0, 1] \rightarrow [0, 1]$ be a smooth function such that $f(t) = 0$ for t near 0 and $f(t) = 1$ for t near 1. Let $\gamma : [0, 1] \rightarrow SO(3)$ be a representative of the nontrivial element of $\pi_1(SO(3))$, with $\gamma(0) = \gamma(1) = 1$. Let B^3 be the unit ball in \mathbb{R}^3 , and for $p \in B^3$, let $|p|$ denote the distance from p to the origin. Define a diffeomorphism of $[0, 1] \times B^3$ by

$$(s, p) \mapsto (s, \gamma(f(s \cdot (1 - |p|)))(p)).$$

This diffeomorphism is the identity near $[0, 1] \times \partial B^3$ and it effects a full twist on the tangent space along $[0, 1] \times \{0\}$.

Once the above obstruction vanishes we can isotope f to a map which is the identity on a neighborhood N of $p \times [0, 1] \cup \mathbb{R}^3 \times \{0, 1\}$.

Choose a family of diffeomorphisms $g_t : \mathbb{R}^3 \times [0, 1] \rightarrow \mathbb{R}^3 \times [0, 1]$, with $t \in [0, 1]$, such that g_0 is the identity, g_t restricted to $\mathbb{R}^3 \times \{0, 1\}$ is the identity for all t , and $g_1(\Sigma) \subset N$. The family of surfaces $f(g_t(\Sigma))$ provides an isotopy from $f(\Sigma) = f(g_0(\Sigma))$ to $f(g_1(\Sigma))$. But f is the identity on N and $g_1(\Sigma) \subset N$, so $f(g_1(\Sigma)) = g_1(\Sigma)$. The family of surfaces $g_t(\Sigma)$ provides an isotopy from $g_1(\Sigma)$ to $g_0(\Sigma) = \Sigma$. Composing these two isotopies provides the desired isotopy from $f(\Sigma)$ to Σ . \square

4.2. Link homology in abstract 3-spheres.

Definition 4.8. *A link homology for links in 3-spheres is a functor*

$$\left\{ \begin{array}{l} \text{link embeddings in oriented } S \cong S^3 \\ \text{link cobordisms in oriented } Y \cong S^3 \times [0, 1] \text{ up to isotopy rel } \partial \end{array} \right\} \rightarrow \left\{ \begin{array}{l} \text{bigraded abelian groups} \\ \text{homogeneous homomorphisms} \end{array} \right\}$$

Theorem 4.9. *KhR_N extends to a link homology theory for links in 3-spheres.*

The proof occupies the remainder of this subsection.

Remark. In the proof of Theorem 4.9, we will show that the sweep-around property from Theorem 1.1 is sufficient to extend a link homology for links in 3-balls to 3-spheres, without using any special properties of KhR_N.

Definition 4.10. Let S be an oriented 3-manifold diffeomorphic to S^3 . For any point $p \in S \setminus L$, we consider L as a link in the 3-ball $S \setminus \{p\}$ and denote by $\pi: T(S, L) \rightarrow S \setminus L$ the bundle of bigraded abelian groups, whose fiber at the point $p \in S \setminus L$ is $\text{KhR}_N(S \setminus \{p\}, L)$ as defined in Definition 4.4.

For any path p_t in $S \setminus L$, we have that $L \times [0, 1] \subset S \times [0, 1] \setminus \{(p_t, t)\}_{t \in [0, 1]} \cong \mathbb{R}^3 \times [0, 1]$. By the results of §4.1, this cobordism induces a parallel transport isomorphism

$$(\text{KhR}_N(p_t): T(S, L)_{p_0} \rightarrow T(S, L)_{p_1}) \stackrel{\text{def}}{=} \text{KhR}_N(S \times [0, 1] \setminus \{(p_t, t)\}_{t \in [0, 1]}, L \times [0, 1])$$

Lemma 4.11. *The parallel transport isomorphisms $\text{KhR}_N(p_t)$ define a flat connection on $T(S, L)$.*

Proof. We have to show that the parallel transport isomorphisms associated to closed loops p_t in $S \setminus L$ are identity maps. Suppose first that p_t is a contractible loop. Then the pair $(S \times [0, 1] \setminus \{(p_t, t)\}_{t \in [0, 1]}, L \times [0, 1])$ is diffeomorphic to a pair $(\mathbb{R}^3 \times [0, 1], \Sigma)$ where Σ is isotopic to an identity link cobordism, which implies that the parallel transport isomorphism $\text{KhR}_N(p_t)$ is the identity. This also implies that the parallel transport isomorphisms associated to isotopic paths between two points p_0 and p_1 in $S \setminus L$ are equal. Now suppose that the loop p_t is a small meridian around a component of L . Then the pair $(S \times [0, 1] \setminus \{(p_t, t)\}_{t \in [0, 1]}, L \times [0, 1])$ is diffeomorphic to a pair $(\mathbb{R}^3 \times [0, 1], \Sigma)$ where Σ is a sweep-around cobordism as in (1.1). By Theorem 1.1, it follows that the parallel transport isomorphism $\text{KhR}_N(p_t)$ is the identity. Since $\pi_1(S \setminus L)$ is generated by such small meridian loops, it follows that the parallel transport isomorphism for every loop p_t is the identity. \square

Definition 4.12. Let $L \subset S$ be a link embedded in a 3-sphere. Then we define the Khovanov–Rozansky homology of L in S to be

$$\text{KhR}_N(S, L) \stackrel{\text{def}}{=} \Gamma_{\text{flat}}(T(S, L)),$$

the bigraded abelian group of flat sections of the bundle $T(S, L)$.

Note that every point $p \in S \setminus L$ induces a grading-preserving isomorphism

$$\text{KhR}_N(S, L) \rightarrow \text{KhR}_N(S \setminus \{p\}, L)$$

of evaluating sections at the point p .

Definition 4.13. Consider a link cobordism $\Sigma \subset W$ in a 4-manifold W diffeomorphic to $S^3 \times [0, 1]$. Let $\Sigma_{\text{in}} \subset W_{\text{in}}$ and $\Sigma_{\text{out}} \subset W_{\text{out}}$ denote the boundary links in the incoming and outgoing boundary 3-spheres of W . Now we define

$$\text{KhR}_N(W, \Sigma): \text{KhR}_N(W_{\text{in}}, \Sigma_{\text{in}}) \rightarrow \text{KhR}_N(W_{\text{out}}, \Sigma_{\text{out}})$$

by first choosing a path $p_t \subset W \setminus \Sigma$ from $p_0 \in W_{\text{in}} \setminus \Sigma_{\text{in}}$ to $p_1 \in W_{\text{out}} \setminus \Sigma_{\text{out}}$. Then we have $W \setminus \{(p_t, t)\}_{t \in [0, 1]} \cong \mathbb{R}^3 \times [0, 1]$ and we declare $\text{KhR}_N(W, \Sigma)(\eta)$, for a flat section $\eta \in \text{KhR}_N(W_{\text{in}}, \Sigma_{\text{in}})$, to be the unique flat section of $\text{KhR}_N(W_{\text{out}}, \Sigma_{\text{out}})$ with value

$$\text{KhR}_N(W, \Sigma)(\eta)(p_{\text{out}}) = \text{KhR}_N(W \setminus \{(p_t, t)\}_{t \in [0, 1]}, \Sigma)(\eta(p_{\text{in}}))$$

Lemma 4.14. *$\text{KhR}_N(W, \Sigma)$ is independent of the choice of the path p_t .*

Proof. Let us first fix a choice of endpoints $p_0 \in W_{\text{in}} \setminus \Sigma_{\text{in}}$ and $p_1 \in W_{\text{out}} \setminus \Sigma_{\text{out}}$. Then any two choices of paths $p_t \in$ and p'_t from p_0 to p_1 can be related by isotopy in $W \setminus \Sigma$ or splicing in a little loop linking a component of Σ . As before, isotopic paths give rise to isotopic surfaces in $\mathbb{R}^3 \times [0, 1]$, which induce equal maps. Similarly, in the case of a linking loop, we can choose a standard local model and then notice that the sweep-around property from Theorem 1.1 implies that the two paths induce the same map. Finally, the independence from the choice of endpoints $p_0 \in W_{\text{in}} \setminus \Sigma_{\text{in}}$ and $p_1 \in W_{\text{out}} \setminus \Sigma_{\text{out}}$ follows as in the proof of Lemma 4.6. \square

This completes the proof of Theorem 4.9.

4.3. **Monoidality.** Links in 3-balls and their cobordisms form a symmetric monoidal category under boundary connect sum, which is respected by KhR_N as we will now see.

Proposition 4.15. *The Khovanov–Rozansky homologies KhR_N are lax symmetric monoidal functors.*

Proof. Let $L_1 \in B_1$ and $L_2 \in B_2$ and write L for the resulting split disjoint union in $B \stackrel{\text{def}}{=} B_1 \#_{\partial} B_2$. We can find a diffeomorphism $\phi: B \rightarrow \mathbb{R}^3$ such that not only is L generic and blackboard-framed, but also the z -projections of the L_1 and L_2 components of L are contained in disjoint disks in \mathbb{R}^2 . Then, monoidality on the chain level is manifest in the definition of KhR_N , and we get

$$\begin{aligned} \text{KhR}_N(B_1, L_1) \otimes \text{KhR}_N(B_2, L_2) &\cong \text{KhR}_N(\phi(L_1)) \otimes \text{KhR}_N(\phi(L_2)) \\ &\rightarrow \text{KhR}_N(\phi(L_1 \sqcup L_2)) \\ &\cong \text{KhR}_N(B_1 \#_{\partial} B_2, L_1 \sqcup L_2) \end{aligned}$$

where the map in the second line comes from the Künneth theorem (this is guaranteed to be an isomorphism when working with field coefficients). The compatibility on the level of morphisms is verified similarly. \square

Given a finite collection of links in 3-balls $L_i \subset B_i$, we can also define

$$\text{KhR}_N(\sqcup_i B_i, \sqcup_i L_i) \stackrel{\text{def}}{=} \bigotimes_i \text{KhR}_N(B_i, L_i).$$

Then the proof of the proposition implies that the boundary connect sum of 3-balls induces natural homomorphisms (and even isomorphisms when working with field coefficients)

$$\text{KhR}_N(\sqcup_i B_i, \sqcup_i L_i) \rightarrow \text{KhR}_N(\#_{\partial} B_i, \sqcup_i L_i).$$

Remark. This monoidality property can be interpreted as saying that KhR_N categorifies the \mathfrak{gl}_N skein algebra of \mathbb{R}^2 . For more on skein algebra categorification we refer to [QW21].

5. A TQFT IN DIMENSIONS $4 + \epsilon$

In this and the following section we construct three alternative 4-categorical structures from Khovanov–Rozansky homology. (The three alternatives are not essentially different; they ought to be different descriptions of the same thing.) These are:

- a “lasagna algebra”, which is a higher dimensional analog of a planar algebra, introduced here,
- a “disklike 4-category”, as defined in [MW12],
- a “braided monoidal 2-category”, in the sense of [BN96].

In fact, we use the construction of a lasagna algebra as a shortcut towards building a disklike 4-category. The construction of a braided monoidal 2-category is independent, and can be read separately. The advantage of the lasagna algebra and disklike 4-category approaches is that they immediately provide invariants of oriented smooth 4-manifolds, valued in bigraded abelian groups. We briefly describe these invariants but do not explore them further.

In §6, we recast Khovanov–Rozansky homology in the more traditional framework of a braided monoidal 2-category \mathbf{KhR}_N with duals. We conjecture that the sweep-around property implies that this braided monoidal 2-category is an $SO(4)$ fixed point in the sense of Lurie [Lur09], and consequently leads to invariants of oriented 4-manifolds using the framework of factorization homology (see also [BZBJ18, BJS21] for related constructions one dimension down). We do not pursue this, preferring the more direct approach to oriented 4-manifold invariants described in this section.

As before, links and link cobordisms are assumed to be oriented and framed, and all diffeomorphisms are oriented in this section.

5.1. **An algebra for the lasagna operad.** Throughout this section we assume familiarity with planar algebras [Jon99].

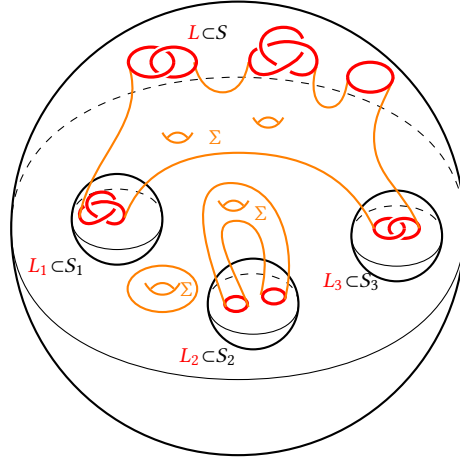

FIGURE 2. A lasagna diagram, projected into 3d

Definition 5.1. A lasagna algebra \mathcal{L} consists of

- for each link L in a 3-sphere S , a (bigraded) abelian group $\mathcal{L}(S, L)$, which depends functorially on the pair (S, L) ,
- for each lasagna diagram D , which, by definition, consists of a 4-ball B , with a finite collection of disjoint 4-balls B_i removed from the interior, with boundary components S (on the outside) and S_i (the boundaries of the removed interior balls B_i), and properly embedded framed oriented surface Σ in the complementary region, meeting the boundary spheres in links L and L_i (see Figure 2), a (homogeneous) homomorphism

$$\mathcal{L}(D) : \bigotimes_i \mathcal{L}(S_i, L_i) \rightarrow \mathcal{L}(S, L),$$

such that

- surfaces Σ and Σ' which are isotopic rel boundary induce identical homomorphisms,
- if $f : D \rightarrow D'$ is a diffeomorphism between lasagna diagrams, then the square

$$\begin{array}{ccc} \bigotimes_i \mathcal{L}(S_i, L_i) & \xrightarrow{\mathcal{L}(D)} & \mathcal{L}(S, L) \\ \downarrow \bigotimes_i \mathcal{L}(f|_{S_i}) & & \downarrow \mathcal{L}(f|_S) \\ \bigotimes_i \mathcal{L}(f(S_i), f(L_i)) & \xrightarrow{\mathcal{L}(D')} & \mathcal{L}(f(S), f(L)) \end{array}$$

commutes,

- a ‘radial’ surface $L \times [0, 1] \subset S \times [0, 1]$ induces the identity map $\mathcal{L}(S, L) \rightarrow \mathcal{L}(S, L)$ (or more precisely, mapping cylinders of diffeomorphisms induce the same map specified for that diffeomorphism by functoriality),

- gluing of a ‘smaller’ lasagna diagram into one of the removed balls of a ‘larger’ lasagna diagram (with compatible boundaries) to obtain a single lasagna diagram is compatible with the corresponding composition of homomorphisms.

We won’t actually spell this out in detail, but one can easily extract from this definition the notion of the lasagna operad (actually a coloured operad, with colours corresponding to links), and that a lasagna algebra is an algebra for that operad. One can of course consider lasagna algebras valued in symmetric monoidal categories other than (bigraded) abelian groups.

The ‘one input ball’ part of a lasagna algebra is essentially equivalent to a functorial invariant of links in 3-spheres: we have an abelian group for each such link, and homomorphisms for cobordisms between them, which compose appropriately. It is not immediately clear that any such functorial invariant extends to a full lasagna algebra, with well-defined operations for multiple input balls. The goal in this section is to show that this is the case for Khovanov–Rozansky homology. In fact, our argument shows that any functorial invariant of links and cobordisms in 3-spheres which satisfies the monoidality property and sweep-around move extends to a lasagna algebra.

Theorem 5.2. *Khovanov–Rozansky homology affords the structure of a lasagna algebra.*

Proof. For a lasagna diagram D (as in Figure 2) we define a homomorphism

$$\mathrm{KhR}_N(D) : \bigotimes_i \mathrm{KhR}_N(S_i, L_i) \rightarrow \mathrm{KhR}_N(S, L),$$

as follows. We first choose points $q_j \in S_j \setminus L_j$ and $q \in S \setminus L$ and then a properly embedded 1-complex $T \subset B$, disjoint from Σ , such that the underlying graph of T is a tree and the endpoints of the 1-complex are $\{q_j, q\}$. Choose a small closed tubular neighborhood N of T , also disjoint from Y . The complement of N in $B \setminus \sqcup B_i$ is diffeomorphic to $\mathbb{R}^3 \times [0, 1]$ with some embedded surface Σ' . We will view Σ' as a bordism between two links in two copies of \mathbb{R}^3 . One copy is identified with $S^q := S \setminus \{q\}$, which contains the link L . The other copy X is the remainder of the boundary, and can be expressed as the boundary connect sum of the 3-balls $S_i^{q_i} := S_i \setminus \{q_i\}$, connected along the tree T . The 3-ball X contains the split disjoint union of the links L_i . Khovanov–Rozansky homology for links in 3-balls gives us a map

$$\mathrm{KhR}_N(\Sigma') : \mathrm{KhR}_N(X, \sqcup_i L_i) \rightarrow \mathrm{KhR}_N(S^q, L)$$

which, together with the monoidality maps from §4.3, specifies a map

$$\mathrm{KhR}_N(D) : \bigotimes_i \mathrm{KhR}_N(S_i, L_i) \cong \bigotimes_i \mathrm{KhR}_N(S_i^{q_i}, L_i) \xrightarrow{T} \mathrm{KhR}_N(X, \sqcup_i L_i) \rightarrow \mathrm{KhR}_N(S^q, L) \cong \mathrm{KhR}_N(S, L).$$

Here the first and last maps are the ‘evaluation’ isomorphisms discussed below Definition 4.12, and we highlight that the monoidality map depends on the tree T .

We must check that the overall map above does not depend on the choices of q_i and T . This is straightforward, so we merely sketch the argument. Isotoping the points q_i does not change the map, by the same argument that showed that KhR_N is well-defined for links in 3-spheres; see §4.2. Isotoping T disjointly from Σ clearly does not affect the map. Changing the combinatorics of the underlying tree of T can be done in such a way that N varies continuously and remains far from Σ , and so does not affect the map. Isotoping T through Σ does not affect the map, thanks to the sweep-around property (see Theorem 1.1 above). Thus $\mathrm{KhR}_N(\Sigma)$ is well-defined.

Next we must show compatibility with the operad composition. For this we consider three lasagna diagrams:

- D_1 with output boundary (S_1, L_1, q_1) , with input boundaries $(S_i, L_i, q_i)_{i \in J}$, surface Σ_1 , and tree T_1 ,

- D_2 with output boundary (S_2, L_2, q_2) , with input boundaries (S_1, L_1, q_1) along with $(S_i, L_i, q_i)_{i \in K}$, surface Σ_2 , and tree T_2
- D , the result of gluing D_1 inside D_2 , with outer boundary (S_2, L_2, q_2) , input boundary $(S_i, L_i, q_i)_{i \in J \cup K}$, surface $\Sigma = \Sigma_1 \cup \Sigma_2$, and tree $T = T_1 \cup T_2$.

Compatibility with the operad composition now boils down to the claim:

$$\text{KhR}_N(D) = \text{KhR}_N(D_2) \circ (\text{KhR}_N(D_1) \otimes \mathbf{1})$$

as maps

$$\left(\bigotimes_{i \in J} \text{KhR}_N(S_i, L_i) \right) \otimes \left(\bigotimes_{i \in K} \text{KhR}_N(S_i, L_i) \right) \rightarrow \text{KhR}_N(S_2, L_2)$$

We compare these two homomorphisms on the level of 3-ball link homologies, that is, with respect to a fixed choice of basepoints q_i and q , and we suppress associators. On this level $\text{KhR}_N(D)$ is determined by the homomorphism

$$(5.1) \quad \left(\bigotimes_{i \in J} \text{KhR}_N(S_i^{q_i}, L_i) \right) \otimes \left(\bigotimes_{i \in K} \text{KhR}_N(S_i^{q_i}, L_i) \right) \xrightarrow{T} \text{KhR}_N(X, \sqcup_i L_i) \rightarrow \text{KhR}_N(S_2^q, L_2)$$

where X denotes the boundary connect sum of the 3-balls $S_i^{q_i}$ for $i \in J \cup K$ along the tree T , and the first map is provided by lax monoidality. On the other hand, the homomorphism $\text{KhR}_N(D_2) \circ (\text{KhR}_N(D_1) \otimes \mathbf{1})$ is determined by the composite

$$\begin{aligned} & \left(\bigotimes_{i \in J} \text{KhR}_N(S_i^{q_i}, L_i) \right) \otimes \left(\bigotimes_{i \in K} \text{KhR}_N(S_i^{q_i}, L_i) \right) \xrightarrow{T_1 \otimes \mathbf{1}} \text{KhR}_N(X_J, \sqcup_{i \in J} L_i) \otimes \left(\bigotimes_{i \in K} \text{KhR}_N(S_i^{q_i}, L_i) \right) \\ & \xrightarrow{\text{KhR}_N(\Sigma'_1) \otimes \mathbf{1}} \text{KhR}_N(S_1^{q_1}, L_1) \otimes \left(\bigotimes_{i \in K} \text{KhR}_N(S_i^{q_i}, L_i) \right) \\ & \xrightarrow{T_2} \text{KhR}_N(X_K, \sqcup_{i \in \{1\} \cup K} L_i) \\ & \xrightarrow{\text{KhR}_N(\Sigma'_2)} \text{KhR}_N(S_2^q, L_2). \end{aligned}$$

Here we write X_J for the boundary connect sum of the 3-balls $S_i^{q_i} := S_i \setminus \{q_i\}$ for $i \in J$ that is determined by T_1 , and X_K for the boundary connect sum of the $S_i^{q_i}$ for $i \in \{1\} \cup K$ along T_2 . After commuting the map induced by Σ'_1 past the second monoidality map, we arrive at

$$(5.2) \quad \left(\bigotimes_{i \in J} \text{KhR}_N(S_i^{q_i}, L_i) \right) \otimes \left(\bigotimes_{i \in K} \text{KhR}_N(S_i^{q_i}, L_i) \right) \xrightarrow{T} \text{KhR}_N(X, \sqcup_{i \in J \cup K} L_i) \xrightarrow{\text{KhR}_N(\Sigma'_2 \circ (\Sigma'_1 \cup \mathbf{1}))} \text{KhR}_N(S_2^q, L_2).$$

Since the link cobordism $\Sigma'_2 \circ (\Sigma'_1 \cup \mathbf{1})$ is isotopic to Σ , the functoriality of KhR_N implies that the maps in (5.1) and (5.2) are equal. This proves the claim. \square

5.2. Skein theory for lasagna algebras. In this section, we use the lasagna algebra described above to construct an invariant $S_0^N(W; L)$ of smooth oriented 4-manifolds W , possibly with a link L in the boundary, valued in bigraded abelian groups. It is akin to the skein modules of 3-manifolds, which can be defined from any ribbon category, except that everything happens one dimension higher. The relationship between this invariant and what we are eventually after is analogous to that between HH_0 and HH_* of an algebra.

Definition 5.3. Let W be a smooth oriented 4-manifold and $L \subset \partial W$ a link. A lasagna filling F of W with boundary L consists of the following data

- a finite collection of ‘small’ 4-balls B_i embedded in the interior of W ;
- a framed oriented surface Σ properly embedded in $X \setminus \sqcup_i B_i$, meeting ∂W in L and meeting each ∂B_i in a link L_i ; and
- for each i , a homogeneous label $v_i \in \text{KhR}_N(\partial B_i, L_i)$.

The bidegree of F is $\text{deg}(F) := \sum_i \text{deg}(v_i) + (0, (1 - N)\chi(\Sigma))$. We will also consider linear combinations of lasagna fillings and impose the relation that lasagna fillings are multilinear in the input labels v_i . Thus, lasagna fillings of W with boundary L form a bigraded abelian group.

For a 4-ball W with a link $L \in \partial W$, a lasagna filling F is equivalent to the data of a lasagna diagram D together with input labels $v_i \in \text{KhR}_N(S_i, L_i)$. In particular, we can compute the *evaluation* $\text{KhR}_N(F) = \text{KhR}_N(D)(v_i) \in \text{KhR}_N(\partial W, L)$.

Definition 5.4. Let W be a smooth oriented 4-manifold and $L \subset \partial W$ a link. Then we define the bigraded abelian group

$$\mathcal{S}_0^N(W; L) \stackrel{\text{def}}{=} \mathbb{Z}\{\text{lasagna fillings } F \text{ of } W \text{ with boundary } L\} / \sim$$

where \sim is the transitive and linear closure of the relation on lasagna fillings for which $F_1 \sim F_2$ if F_1 has an input ball B_1 with label v_1 , and F_2 can be obtained from F_1 by replacing B_1 with a third lasagna filling F_3 of a 4-ball such that $v_1 = \text{KhR}_N(F_3)$, followed by an isotopy rel boundary. This is illustrated in Figure 3.

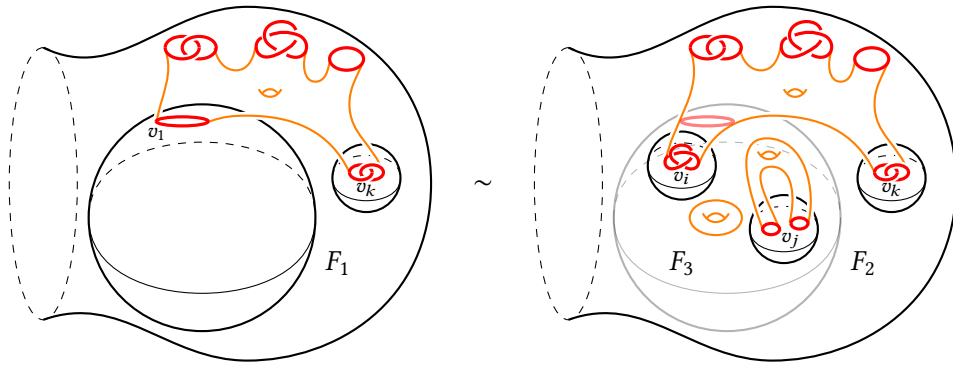

FIGURE 3.

The relation \sim is homogeneous and, thus, $\mathcal{S}_0^N(W; L)$ is a bigraded abelian group since the bidegree of a cobordism map $\text{KhR}_N(\Sigma)$ is $(0, (1 - N)\chi(\Sigma))$ and the Euler characteristic of surfaces is additive under gluing along links.

Remark 5.5. If L represents a non-zero class in $H_1(W)$, then we have $\mathcal{S}_0^N(W; L) = \emptyset$ since there are no compatible lasagna fillings. It would be interesting to relate \mathcal{S}_0^N to \mathfrak{gl}_N versions of the invariants of links in $S^2 \times S^1$ or $(S^2 \times S^1)^{\#g}$ constructed by Rozansky [Roz10] and Willis [Wil21] respectively, which are trivial for homologically non-zero links.

Example 5.6. If W is a standard 4-ball with $L \subset \partial W = S^3$, then the evaluation of lasagna fillings induces an isomorphism $\text{ev}: \mathcal{S}_0^N(W; L) \cong \text{KhR}_N(S^3, L)$. In other words, the above complicated quotient yields the usual $\text{KhR}_N(S^3, L)$ in this case.

Proof. It follows from Theorem 5.2 that equivalent lasagna fillings of W have equal evaluation. Thus, we get a well-defined homomorphism $\text{ev}: \mathcal{S}_0^N(W; L) \rightarrow \text{KhR}_N(S^3, L)$, which is surjective since any homogeneous $v \in \text{KhR}_N(S^3, L)$ appears as the image of a radial lasagna filling F_v . Similarly, if two lasagna fillings F_1 and F_2 have equal evaluation $v \in \text{KhR}_N(S^3, L)$, then we observe $F_1 \sim F_v \sim F_2$, and so ev is injective. \square

Having defined the skein module $\mathcal{S}_0^N(W; L)$, we now proceed to constructing a disklike 4-category. This will also lead to a more refined invariant, taking the form of a chain complex with 0-th homology $\mathcal{S}_0^N(W; L)$.

5.3. A disklike 4-category. We very briefly recall the key points of the definition of a disklike 4-category, from §6 of [MW12]. A disklike n -category \mathcal{C} consists of:

- for each $0 \leq k \leq n$, a functor

$$\mathcal{C}^k : \{k\text{-balls and diffeomorphisms}\} \rightarrow \text{Set}$$

(and we interpret $\mathcal{C}^k(X)$ as the set of k -morphisms with shape X),

- for each $k - 1$ -ball Y in the boundary of a k -ball X , a *restriction* map $\mathcal{C}^k(X) \rightarrow \mathcal{C}^{k-1}(Y)$ (to be more careful, these restriction maps only need to be defined on sufficiently large subsets of $\mathcal{C}^k(X)$, for example to allow for transversality issues),
- for each k -ball X presented as the gluing of two k -balls X_1 and X_2 along a common $k - 1$ -ball Y in their boundaries, a gluing map

$$\mathcal{C}^k(X_1) \times_{\mathcal{C}^{k-1}(Y)} \mathcal{C}^k(X_2) \rightarrow \mathcal{C}^k(X),$$

- such that these gluing operations are compatible with the action of diffeomorphisms, and associative on the nose,
- and that two diffeomorphisms of n -balls which are isotopic rel boundary act identically,
- along with some data and axioms concerning identities which we omit here.

(As a reminder, the surprising feature of this definition is that while gluing is required to be strictly associative, this definition actually models fully weak n -categories. The key point is that we do not choose canonical models for the shape of a k -morphism, and it is up to ‘the end user’ to pick reparametrisations of glued balls back to any standard model balls that they prefer. It is these reparametrisations that are responsible for introducing all the difficult structural isomorphisms of most definitions. This is analogous to the idea of a Moore loop space, which has a strictly associative composition, versus an ordinary loop space, which has a complicated higher associator structure described by Stasheff polyhedra.)

As explained in [MW12], one of the primary examples of a disklike n -category is string diagrams for a pivotal traditional n -category. This string diagram construction works just as well for a lasagna algebra (which is essentially a pivotal 4-category with trivial 0- and 1-morphisms). Specifically, starting from the lasagna algebra KhR_N , we define a disklike 4-category KhR_N as follows:

- For X a 0-ball, we define $\text{KhR}_N^0(X)$ to be a single-element set.
- For X a 1-ball, we define $\text{KhR}_N^1(X)$ to be a single-element set.
- For X a 2-ball, we define $\text{KhR}_N^2(X)$ to be the set of all configurations of finitely many framed oriented points in X .
- For X a 3-ball, we define $\text{KhR}_N^3(X)$ to be the set of all framed oriented tangles (*not* up to isotopy) properly embedded in X . If c is a finite configuration of oriented points in ∂X , we define $\text{KhR}_N^3(X; c)$ to be the set of all oriented tangles which restrict to c on ∂X .

- For X a 4-ball, and L a link in ∂X , we define $\text{KhR}_N^4(X; L)$ to be the bigraded abelian group $\mathcal{S}_0^N(X; L)$ defined above, that is, all lasagna fillings of X which restrict to L on the boundary, modulo relations described above. Recall that by Example 5.6 we know $\text{KhR}_N^4(X; L) \cong \text{KhR}_N(\partial X, L)$.

We define $\text{KhR}_N^4(X; L)$ to be lasagna fillings modulo relations rather than simply defining it to be $\text{KhR}_N(\partial X, L)$ in order to make it easier to define composition below.

We will henceforth drop superscripts and write $\text{KhR}_N(X)$ instead of $\text{KhR}_N^k(X)$.

In dimensions 0 through 3, it is clear that $\text{KhR}_N(X)$ is functorial with respect to diffeomorphisms. In dimension 4, it is clear the diffeomorphisms act on lasagna fillings; what remains is to show that the relations we impose are compatible with the action of diffeomorphisms. Specifically, for a diffeomorphism f we must show that if $\text{KhR}_N(F) = \text{KhR}_N(F')$ then $\text{KhR}_N(f(F)) = \text{KhR}_N(f(F'))$. This follows from the fact that any diffeomorphism of a 4-ball (rel boundary) is isotopic to the identity away from a small 4-ball in the interior. We can arrange that this small 4-ball is disjoint from Σ and the B_i . The argument is similar to (but simpler than) the argument given in Lemma 4.7.

We must now define gluing (composition) of morphisms. In dimensions 0 through 3 the morphisms are purely geometric and the gluing is defined to be the obvious geometric gluing of submanifolds. In dimension 4, there is again an obvious geometric gluing map of lasagna fillings. We must show that this gluing map is compatible with the relations we impose on fillings. This follows from the operad composition property proved in the previous section.

Finally, the (omitted above) axioms about identities require that we check that 4-ball diffeomorphisms which are supported away from the surface Σ act trivially. The diffeomorphism action on lasagna fillings is just moving submanifolds around (and, if the internal balls move, applying the S^3 -functoriality action from the first piece of data for a lasagna algebra to the labels), so a diffeomorphism supported away from the surface and the internal balls does not change a lasagna filling.

5.4. Blob homology. Having built a disklike 4-category we immediately obtain an alternative description of the skein module $\mathcal{S}_0^N(W; L)$ for a link in the boundary of any oriented smooth 4-manifold W , as first introduced in §5.2.

This is the construction from [MW12, §6.3], which describes $\mathcal{S}_0^N(W; L)$ as a colimit, taken over all ways of decomposing a 4-manifold W into a gluing of closed balls (with some regularity conditions on the ways these balls meet). For any such decomposition, we draw compatible links in the boundaries of each of the balls (i.e. if two balls meet along some 3-manifold, the intersections of the two links with that 3-manifold are tangles, and identical, and a similar condition holds for any ball meeting ∂W). Then the bigraded abelian group at such a decomposition is the direct sum, over the choices of link labels, of the tensor products of the Khovanov–Rozansky homologies of each link. The arrows in the colimit diagram are ways of coarsening the decomposition by gluing several balls together into a single ball. The gluing maps for a disklike 4-category provide morphisms of bigraded abelian groups. Finally, the skein module invariant $\mathcal{S}_0^N(W; L)$ associated to W is just the colimit of this diagram.

We will leave it as an exercise to the interested reader to verify that these two constructions actually give the same result!

Our motivation for introducing the disklike 4-category is that the construction of [MW12, §6.3] actually gives much more. Associated to any link L in the boundary of a 4-manifold W , we obtain the blob complex (with coefficients in the disklike 4-category KhR_N), which we write as $\mathcal{B}_*(\text{KhR}_N)(W; L)$. (One approach to the definition of this complex is by replacing the colimit described above with an appropriate homotopy colimit, see [MW12, §7].) This has a new homological grading, unrelated to the internal homological grading from Khovanov–Rozansky homology. The 0-th homology of this complex recovers

the bigraded abelian group $\mathcal{S}_0^N(W; L)$, but the higher blob homology groups, denoted by $\mathcal{S}_i^N(W; L)$ for $i > 0$, potentially carry further information.

Attempting any calculations of this invariant, or of its 0-th homology in either formulation, remains beyond the scope of this paper, and developing appropriate computational tools is an open problem for future work (e.g. [MN20]). One such tool should come from a categorification of the \mathfrak{gl}_N skein relation, namely the skein exact triangle for Khovanov–Rozansky chain complexes in \mathbb{R}^3 , which induces a long exact sequence on homology groups. For a skein triple of links in the boundary of some interesting 4-manifold W we have every reason to expect that the corresponding sequence on the level of the skein module \mathcal{S}_0^N is no longer exact. We do, however, obtain long exact sequences on the level of the blob complex, which give rise to a spectral sequence that relates the skein modules \mathcal{S}_0^N for the three links. In fact, the study of these spectral sequences was the original motivation for the blob complex (however ahistorical this might seem, given the publication dates).

6. A PIVOTAL BRAIDED MONOIDAL 2-CATEGORY

In this section, we define a semistrict braided monoidal 2-category \mathbf{KhR}_N in the sense of [KV94] (and in fact, in the stricter sense of [BN96]) from Khovanov–Rozansky homology. The spaces of 2-morphisms form bigraded abelian groups.

Recall that one expects that braided monoidal 2-categories should be the same as 4-categories which are ‘boring at the bottom two levels’, so there is a shift by two in the dimensions of the morphisms relative to the previous section.

The available definition of a braided monoidal 2-category has already been strictified quite a bit, and this necessitates jumping through some hoops to even get started. Rather than defining the morphisms of the 2-category (which would be the 3-morphisms of the corresponding 4-category) to simply be arbitrary embedded tangles, we will need to introduce a particular combinatorial model of a tangle diagram.

Definition 6.1. The category \mathbf{TD} of oriented tangle diagrams has objects given by finite words in the alphabet $\{\uparrow, \downarrow\}$, including the empty word. The morphisms are *admissible* words in the alphabet $\{\text{cup}_i, \text{cap}_i, \text{crossing}_i, \text{crossing}_i^{-1}\}_{i \geq 0}$ of generating morphisms.

The *realization* $r(t)$ of a morphism $t: A \rightarrow B$ is a tangle diagram drawn in the square $[0, 1] \times [0, 1]$ by first placing the words A and B as collections of oriented tangle endpoints on $[0, 1] \times \{0\}$ and $[0, 1] \times \{1\}$ respectively, and then constructing an oriented tangle diagram starting from the bottom A by attaching cups, caps, crossings or inverse crossings with i parallel strands to the left, as specified by the t . The word t is defined to be *admissible* if this procedure succeeds in generating an oriented tangle diagram. We will consider these diagrams up to individually rescaling the x - and y -coordinates in $[0, 1] \times [0, 1]$ by orientation-preserving diffeomorphisms of $[0, 1]$. As such, every morphism in \mathbf{TD} has a unique realization, and we say that the morphism is the *Morse data* of the oriented tangle diagram.

The composition of morphisms in \mathbf{TD} is given by concatenating lists of generating morphisms.

The remainder of this section contains the definition of the semistrict braided monoidal 2-category \mathbf{KhR}_N . We will first define this as a 2-category and subsequently add a semistrict monoidal structure and a braiding.

6.1. A strict 2-category. The strict 2-category \mathbf{KhR}_N consists of the following data:

- The objects are given by finite words in the alphabet $\{\uparrow, \downarrow\}$, including the empty word.
- The 1-morphisms are *admissible* words in the alphabet

$$\{\text{cup}_i, \text{cap}_i, \text{crossing}_i, \text{crossing}_i^{-1}\}_{i \geq 0}$$

of generating morphisms.

The horizontal composition of 1-morphisms is given by concatenation of words, which is strictly associative.

- Given a pair of 1-morphisms $f, g: A \rightarrow B$, the bigraded abelian group of 2-morphisms from f to g is defined to be

$$\mathbf{KhR}_N(f, g) := \mathbf{KhR}_N(\mathrm{Tr}(r(f), r(g))) := \mathbf{KhR}_N \left(\begin{array}{c} \text{a} \\ \text{f} \end{array} \right).$$

Here the link diagram $\mathrm{Tr}(r(f), r(g))$ is constructed from the realizations $r(f)$ and $r(g)$ by reflecting $r(g)$ in a horizontal line, reversing its orientations, composing with $r(f)$ and closing off as shown in the figure². Note that this is well-defined because the Khovanov–Rozansky invariants of two link diagrams, which are planar-isotopic through link diagrams with identical Morse data, are canonically isomorphic.

For 1-morphisms $f, g: A \rightarrow B$ and $k, l: B \rightarrow C$, the horizontal composition of 2-morphisms $\mathbf{KhR}_N(f, g) \otimes \mathbf{KhR}_N(k, l) \rightarrow \mathbf{KhR}_N(fk, gl)$ is defined as the homogeneous homomorphism computed as follows:

$$\mathbf{KhR}_N \left(\begin{array}{c} \text{a} \\ \text{f} \end{array} \right) \otimes \mathbf{KhR}_N \left(\begin{array}{c} \text{l} \\ \text{k} \end{array} \right) \rightarrow \mathbf{KhR}_N \left(\begin{array}{c} \text{l} \\ \text{k} \end{array} \right) \begin{array}{c} \text{a} \\ \text{f} \end{array} \rightarrow \mathbf{KhR}_N \left(\begin{array}{c} \text{l} \\ \text{k} \end{array} \right) \begin{array}{c} \text{a} \\ \text{f} \end{array} \rightarrow \mathbf{KhR}_N \left(\begin{array}{c} \text{a} \\ \text{l} \\ \text{k} \\ \text{f} \end{array} \right)$$

Here we have used the monoidality map between the tensor product of Khovanov–Rozansky homologies of two link diagrams and the homology of the split disjoint union of the diagrams, and then cobordism maps induced by a collection of saddles and a particular type of planar isotopy. Using functoriality of \mathbf{KhR}_N , it is easy to check that the horizontal composition is associative.

Now, for 1-morphisms $f, g, h: A \rightarrow B$, the vertical composition of 2-morphisms $\mathbf{KhR}_N(f, g) \otimes \mathbf{KhR}_N(g, h) \rightarrow \mathbf{KhR}_N(f, h)$ is defined as the homogeneous homomorphism computed as follows:

$$\mathbf{KhR}_N \left(\begin{array}{c} \text{a} \\ \text{f} \end{array} \right) \otimes \mathbf{KhR}_N \left(\begin{array}{c} \text{v} \\ \text{g} \end{array} \right) \rightarrow \mathbf{KhR}_N \left(\begin{array}{c} \text{v} \\ \text{g} \\ \text{a} \\ \text{f} \end{array} \right) \rightarrow \mathbf{KhR}_N \left(\begin{array}{c} \text{v} \\ \text{f} \end{array} \right)$$

Here, the interesting map is induced by a link cobordism which is cylindrical over the top and bottom quarters of the link diagrams, and which can be constructed as $r(g) \times \text{halfcircle}$ in the middle. More explicitly, it consists of a composition of elementary cobordisms which cancel cups with caps and positive with negative crossings in $r(g)$ and its reflection.

The identity 2-morphism 1_f on a 1-morphism $f: A \rightarrow B$ is defined to be the image of the unit under the homomorphism

$$\mathbb{Z} = \mathbf{KhR}_N(\emptyset) \rightarrow \mathbf{KhR}_N \left(\begin{array}{c} \text{1}_B \\ \text{1}_A \\ \text{f} \end{array} \right) \rightarrow \mathbf{KhR}_N \left(\begin{array}{c} \text{1}_B \\ \text{f} \end{array} \right)$$

which is induced by the link cobordism which first creates a collection of concentric circles as specified by A , and then pairs of cups and caps, crossings and inverse crossings, to form $r(f)$

²We omit the realizations $r(-)$ in this and all following figures.

It is straightforward to verify that with this data, \mathbf{KhR}_N satisfies the axioms (i)-(viii) of a semistrict monoidal 2-category as presented in [BN96, Lemma 4]. In fact, each axiom expresses equalities of 2-morphisms that are computed via Khovanov–Rozansky cobordisms maps, and their images are equal since the relevant link cobordisms are isotopic.

Remark 6.2. The definitions of the 2-morphism spaces of \mathbf{KhR}_N and the composition operations are motivated by the isomorphisms

$$\mathbf{KhR}_N(f, g) \cong \mathbf{HCh}^b(\mathbf{Foam}_N)(\llbracket f \rrbracket, \llbracket g \rrbracket),$$

where the latter denotes the cohomology category of the dg category of bounded chain complexes over \mathbf{Foam}_N (compare with [CMW09, Proposition 3.1]). Under these isomorphisms, the horizontal composition corresponds to stacking tangles, the tensor product corresponds to placing tangles side by side, and the vertical composition corresponds to composing homotopy classes of chain maps. In the following, we will take this space saving point of view when describing 2-morphisms. For example, we will say that the 2-morphism in (6.1) is induced by the movie of tangle diagrams:

6.3. A braided monoidal 2-category. Finally, we equip \mathbf{KhR}_N with the structure of a braided monoidal 2-category. This consists of the following data:

- (1) The semistrict monoidal 2-category $(\mathbf{KhR}_N, \otimes, I)$.
- (2) A pseudonatural equivalence $R: \otimes \rightarrow \otimes^{\text{op}}$, which assigns to pairs of objects A and B the 1-morphism $R_{A,B}: A \otimes B \rightarrow B \otimes A$ given by the Morse datum of an (oriented) braid diagram of the form

$$R_{A,B} \stackrel{\text{def}}{=} \begin{array}{c} \text{U} \\ \text{R} \end{array}$$

In this intentionally asymmetric braid diagram, we see boundary points $A \otimes B$ at the bottom and $B \otimes A$ at the top. Additionally, for a pair of 1-morphisms $f: A \rightarrow A'$ and $g: B \rightarrow B'$, it assigns the 2-isomorphism induced by the isotopy:

- (3) Additionally there is an invertible modification $\tilde{R}_{-|-,-}$, which associates to triples A, B and C of objects the 2-isomorphisms

$$\tilde{R}_{(A|B,C)}: (R_{A,B} \otimes C)(B \otimes R_{A,C}) \rightarrow R_{A,B \otimes C}$$

which are induced by isotopies of the following type

Similarly, the definition of a braided monoidal 2-category calls for the existence of an invertible modification $\tilde{R}_{-|-,-}$, which, however, in the case of \mathbf{KhR}_N is simply the identity modification.

Using the functoriality of Khovanov–Rozansky homology it is straightforward to check that these data satisfy the axioms of a braided monoidal 2-category as in [BN96, Definition 6].

6.4. **Duality.** The braided monoidal 2-category \mathbf{KhR}_N has duals in the sense of [BMS12]. This is a slight modification of the duality proposed by [BL03] and used by [Mac99]. Following [BMS12], instead of three dualities we only consider two dualities $\#$ and $*$ which correspond to rotations by π in two different axes.

For an object A , the dual object $A^\#$ is obtained by reversing the word A and then exchanging orientations $\uparrow \leftrightarrow \downarrow$. On identity 1-morphisms, this corresponds to the result of a π rotation in a vertical line, followed by a change of orientation. There are unit and counit 1-morphisms $i_A: I \rightarrow A \otimes A^\#$ and $e_A: A^\# \otimes A \rightarrow I$ given by nested collections of cups and caps, as well as a triangulator 2-isomorphism $T_A: (i_A \otimes A)(A \otimes e_A) \rightarrow A$ represented by the obvious string-straightening isotopy. It is clear that $A^{\#\#} = A$.

Every 1-morphism $f: A \rightarrow B$ in \mathbf{KhR}_N has a simultaneous left and right adjoint $f^*: B \rightarrow A$ which is given by the Morse data of the result of reflecting $r(f)$ by π in a horizontal axis and then reversing orientations (previously we have suggestively drawn this as a reflected f in figures). Further, there are unit and counit 2-morphisms $i_f: 1_A \rightarrow ff^*$ and $e_f: f^*f \rightarrow 1_B$, which satisfy the expected identities $(i_ff)(fe_f) = 1_f$ and $(f^*i_f)(e_ff^*) = 1_{f^*}$. It is clear that $f^{**} = f$.

For any 2-morphism $\alpha: f \rightarrow g$, we denote by $\alpha^*: g^* \rightarrow f^*$ the 2-morphism obtained as the image under the isomorphism

$$\mathbf{KhR}_N \left(\begin{array}{c} \text{a} \\ \text{f} \end{array} \right) \rightarrow \mathbf{KhR}_N \left(\begin{array}{c} \text{f} \\ \text{a} \end{array} \right)$$

induced by a planar anticlockwise π -rotation of the shown link diagrams. The dualities $*$ and $\#$ satisfy a host of unsurprising compatibility relations with the tensor product and the horizontal and vertical composition, which are consequences of the functoriality of \mathbf{KhR}_N . The only non-trivial relation is that for $\alpha \in \mathbf{KhR}_N(f, g)$ we have $\alpha^{**} = \alpha$, which is implicit in Definition 2.5, using the fact that foams in \mathbf{Foam}_N are considered up to isotopy relative to the boundary.

6.5. **Pivotality.** In [Mac99] Mackaay introduces the notion of sphericity for monoidal 2-categories with suitable duals. This boils down to the extra structure providing natural 2-isomorphisms between right- and left-traces of 1-endomorphisms.

$$\begin{array}{c} \text{f} \\ \text{a} \end{array} \rightarrow \begin{array}{c} \text{a} \\ \text{f} \end{array}$$

For a braided monoidal 2-category with duals, such as \mathbf{KhR}_N , which is *categorified ribbon* in the sense that it admits 2-isomorphisms that provide a vertical categorification of the framed Reidemeister I move³, such isomorphisms always exist. In fact there are two natural choices, corresponding to sliding the closure arcs over or under the diagram for f :

The sweep-around property implies that these two choices produce equal 2-isomorphisms in \mathbf{KhR}_N . (Compare [HPT16, Prop A.4], for an apparently analogous situation one dimension down.)

Motivated by the equivalent fact that \mathbf{KhR}_N carries a well-defined action of $\text{Diff}^+(S^3)$, we propose that \mathbf{KhR}_N should be a prototypical example of some future definition of a $SO(4)$ -pivotal braided monoidal 2-category, and suggest the possibility that these are the $SO(4)$ fixed points in the braided monoidal 2-categories with duals.

³In contrast, the property of being *spatial* in [BMS12] is a horizontal categorification of the framed Reidemeister I move.

Remark 6.3. An analogous trigraded semistrict braided monoidal 2-category \mathbf{KhR}_∞ can be constructed from the triply-graded Khovanov–Rozansky homology, which categorifies the HOMFLY-PT polynomial. This uses the functoriality of Rouquier complexes in the homotopy categories of type A Soergel bimodules under braid cobordisms, which has been proven by [EK10b]. The 2-category \mathbf{KhR}_∞ admits vertical duals $*$, but it has no duality $\#$ with respect to its monoidal structure. It is an open problem to find a categorification of the HOMFLY-PT polynomial that allows the construction of a version of \mathbf{KhR}_∞ that admit duals, and beyond that an $SO(4)$ -pivotal structure.

REFERENCES

- [APS04] Marta M. Asaeda, Józef H. Przytycki, and Adam S. Sikora. Categorification of the Kauffman bracket skein module of I -bundles over surfaces. *Algebr. Geom. Topol.*, 4:1177–1210, 2004. [MR2113902](#) [DOI:10.2140/agt.2004.4.1177](#) [arXiv:math/0409414](#).
- [AS19] Mohammed Abouzaid and Ivan Smith. Khovanov homology from Floer cohomology. *J. Amer. Math. Soc.*, 32(1):1–79, 2019. [MR3867999](#) [DOI:10.1090/jams/902](#) [arXiv:1504.01230](#).
- [Ati88] Michael Atiyah. Topological quantum field theories. *Inst. Hautes Études Sci. Publ. Math.*, (68):175–186 (1989), 1988. [MR1001453](#).
- [BJS21] Adrien Brochier, David Jordan, and Noah Snyder. On dualizability of braided tensor categories. *Compos. Math.*, 157(3):435–483, 2021. [MR4228258](#) [DOI:10.1112/s0010437x20007630](#) [arXiv:1804.07538](#).
- [BL03] John C. Baez and Laurel Langford. Higher-dimensional algebra. IV. 2-tangles. *Adv. Math.*, 180(2):705–764, 2003. [MR2020556](#) [DOI:10.1016/S0001-8708\(03\)00018-5](#) [arXiv:math/9811139](#).
- [Bla10] Christian Blanchet. An oriented model for Khovanov homology. *J. Knot Theory Ramifications*, 19(2):291–312, 2010. [MR2647055](#) [DOI:10.1142/S0218216510007863](#) [arXiv:1405.7246](#).
- [BMS12] John W. Barrett, Catherine Meusburger, and Gregor Schaumann. Gray categories with duals and their diagrams, 2012. [arXiv:1211.0529](#).
- [BN96] John C. Baez and Martin Neuchl. Higher-dimensional algebra. I. Braided monoidal 2-categories. *Adv. Math.*, 121(2):196–244, 1996. [MR1402727](#) [DOI:10.1006/aima.1996.0052](#) [arXiv:q-alg/9511013](#).
- [BN05] Dror Bar-Natan. Khovanov’s homology for tangles and cobordisms. *Geom. Topol.*, 9:1443–1499, 2005. [arXiv:math.GT/0410495](#) [MR2174270](#) [DOI:10.2140/gt.2005.9.1443](#).
- [BNM06] Dror Bar-Natan and Scott Morrison. The Karoubi envelope and Lee’s degeneration of Khovanov homology. *Algebr. Geom. Topol.*, 6:1459–1469, 2006. [arXiv:math.GT/0606542](#) [MR2253455](#) [DOI:10.2140/agt.2006.6.1459](#).
- [BPW19] Anna Beliakova, Krzysztof K. Putyra, and Stephan M. Wehrli. Quantum link homology via trace functor I. *Invent. Math.*, 215(2):383–492, 2019. [MR3910068](#) [DOI:10.1007/s00222-018-0830-0](#) [arXiv:1605.03523](#).
- [BZBJ18] David Ben-Zvi, Adrien Brochier, and David Jordan. Integrating quantum groups over surfaces. *J. Topol.*, 11(4):873–916, 2018. [MR3847209](#) [DOI:10.1112/topo.12072](#) [arXiv:1501.04652](#).
- [CF94] Louis Crane and Igor B. Frenkel. Four-dimensional topological quantum field theory, Hopf categories, and the canonical bases. volume 35, pages 5136–5154. 1994. *Topology and physics*.
- [CK08a] Sabin Cautis and Joel Kamnitzer. Knot homology via derived categories of coherent sheaves. I. The $\mathfrak{sl}(2)$ -case. *Duke Math. J.*, 142(3):511–588, 2008. [MR2411561](#) [DOI:10.1215/00127094-2008-012](#) [arXiv:math/0701194](#).
- [CK08b] Sabin Cautis and Joel Kamnitzer. Knot homology via derived categories of coherent sheaves. II. \mathfrak{sl}_m case. *Invent. Math.*, 174(1):165–232, 2008. [MR2430980](#) [DOI:10.1007/s00222-008-0138-6](#) [arXiv:0710.3216](#).
- [CKM14] Sabin Cautis, Joel Kamnitzer, and Scott Morrison. Webs and quantum skew Howe duality. *Math. Ann.*, 360(1-2):351–390, 2014. [arXiv:1210.6437](#) [MR3263166](#) [DOI:10.1007/s00208-013-0984-4](#).
- [CKY97] Louis Crane, Louis H. Kauffman, and David N. Yetter. State-sum invariants of 4-manifolds. *J. Knot Theory Ramifications*, 6(2):177–234, 1997. [MR1452438](#) [DOI:10.1142/S0218216597000145](#) [arXiv:hep-th/9409167](#).
- [CMW09] David Clark, Scott Morrison, and Kevin Walker. Fixing the functoriality of Khovanov homology. *Geom. Topol.*, 13(3):1499–1582, 2009. [arXiv:math.GT/0701339](#) [MR2496052](#) [DOI:10.2140/gt.2009.13.1499](#).
- [Cra95] Louis Crane. Clock and category: is quantum gravity algebraic? *J. Math. Phys.*, 36(11):6180–6193, 1995. [MR1355904](#) [DOI:10.1063/1.531240](#) [arXiv:gr-qc/9504038](#).
- [Cra98] Sjoerd E. Crans. Generalized centers of braided and sylleptic monoidal 2-categories. *Adv. Math.*, 136(2):183–223, 1998. [MR1626844](#) [DOI:10.1006/aima.1998.1720](#).
- [CRS97] J. Scott Carter, Joachim H. Rieger, and Masahico Saito. A combinatorial description of knotted surfaces and their isotopies. *Adv. Math.*, 127(1):1–51, 1997. [MR1445361](#).

- [CS93] J. Scott Carter and Masahico Saito. Reidemeister moves for surface isotopies and their interpretation as moves to movies. *J. Knot Theory Ramifications*, 2(3):251–284, 1993. [MR1238875](#).
- [EK10a] Ben Elias and Mikhail Khovanov. Diagrammatics for Soergel categories. *Int. J. Math. Math. Sci.*, pages Art. ID 978635, 58, 2010. [MR3095655](#) DOI:10.1155/2010/978635 [arXiv:0902.4700](#).
- [EK10b] Ben Elias and Dan Krasner. Rouquier complexes are functorial over braid cobordisms. *Homology Homotopy Appl.*, 12(2):109–146, 2010. [MR2721032](#) [euclid.hha/1296223879](#) [arXiv:0906.4761](#).
- [EQ16] Ben Elias and You Qi. A categorification of quantum $\mathfrak{sl}(2)$ at prime roots of unity. *Adv. Math.*, 299:863–930, 2016. [MR3519482](#) DOI:10.1016/j.aim.2016.06.002 [arXiv:1503.05114](#).
- [ES19] Tobias Ekholm and Vivek Shende. Skeins on Branes. Jan 2019. [arXiv:1901.08027](#).
- [ETW18] Michael Ehrig, Daniel Tubbenhauer, and Paul Wedrich. Functoriality of colored link homologies. *Proc. Lond. Math. Soc. (3)*, 117(5):996–1040, 2018. [MR3877770](#) DOI:10.1112/plms.12154 [arXiv:1703.06691](#).
- [FGMW10] Michael Freedman, Robert Gompf, Scott Morrison, and Kevin Walker. Man and machine thinking about the smooth 4-dimensional Poincaré conjecture. *Quantum Topol.*, 1(2):171–208, 2010. [arXiv:0906.5177](#) [MR2657647](#) DOI:10.4171/QT/5.
- [GHW21] Eugene Gorsky, Matthew Hogancamp, and Paul Wedrich. Derived traces of Soergel categories. *Int. Math. Res. Not. IMRN*, 2021. DOI:10.1093/imrn/rnab019 [arXiv:2002.06110](#).
- [GLW18] J. Elisenda Grigsby, Anthony M. Licata, and Stephan M. Wehrli. Annular Khovanov homology and knotted Schur-Weyl representations. *Compos. Math.*, 154(3):459–502, 2018. [MR3731256](#) DOI:10.1112/S0010437X17007540 [arXiv:1505.04386](#).
- [GM21] Sergei Gukov and Ciprian Manolescu. A two-variable series for knot complements. *Quantum Topol.*, 12(1):1–109, 2021. [arXiv:1904.06057](#).
- [Gor04] Bojan Gornik. Note on Khovanov link cohomology, 2004. [arXiv:math/0402266](#).
- [GPPV20] Sergei Gukov, Du Pei, Pavel Putrov, and Cumrun Vafa. BPS spectra and 3-manifold invariants. *J. Knot Theory Ramifications*, 29(2):2040003, 85, 2020. [MR4089709](#) DOI:10.1142/S0218216520400039 [arXiv:1701.06567](#).
- [GPV17] Sergei Gukov, Pavel Putrov, and Cumrun Vafa. Fivebranes and 3-manifold homology. *J. High Energy Phys.*, (7):071, front matter+80, 2017. [MR3686727](#) DOI:10.1007/JHEP07(2017)071 [arXiv:1602.05302](#).
- [GSV05] Sergei Gukov, Albert Schwarz, and Cumrun Vafa. Khovanov-Rozansky homology and topological strings. *Lett. Math. Phys.*, 74(1):53–74, 2005. [MR2193547](#) DOI:10.1007/s11005-005-0008-8 [arXiv:hep-th/0412243](#).
- [HPT16] André Henriques, David Penneys, and James Tener. Categorified trace for module tensor categories over braided tensor categories. *Doc. Math.*, 21:1089–1149, 2016. [MR3578212](#) [arXiv:1509.02937](#).
- [HRW3] Matthew Hogancamp, David E. V. Rose, and Paul Wedrich. A Kirby color for Khovanov homology, 2022. [arXiv:2210.05640](#).
- [Jon85] Vaughan F. R. Jones. A polynomial invariant for knots via von Neumann algebras. *Bull. Amer. Math. Soc. (N.S.)*, 12(1):103–111, 1985. [MR766964](#) DOI:10.1090/S0273-0979-1985-15304-2.
- [Jon99] Vaughan F. R. Jones. Planar algebras, I, 1999. [arXiv:math.QA/9909027](#).
- [Kan19] Sungkyung Kang. Link homology theories and ribbon concordances., 2019. [arXiv:1909.06969](#).
- [Kho00] Mikhail Khovanov. A categorification of the Jones polynomial. *Duke Math. J.*, 101(3):359–426, 2000. [MR1740682](#) DOI:10.1215/S0012-7094-00-10131-7 [arXiv:math.QA/9908171](#).
- [Kho06] Mikhail Khovanov. Link homology and Frobenius extensions. *Fund. Math.*, 190:179–190, 2006. [MR2232858](#) [arXiv:math.QA/0411447](#).
- [Kho16] Mikhail Khovanov. Hopfological algebra and categorification at a root of unity: the first steps. *J. Knot Theory Ramifications*, 25(3):1640006, 26, 2016. [MR3475073](#) DOI:10.1142/S021821651640006X [arXiv:math/0509083](#).
- [KL10] Mikhail Khovanov and Aaron D. Lauda. A categorification of quantum $\mathfrak{sl}(n)$. *Quantum Topol.*, 1(1):1–92, 2010. [arXiv:0807.3250](#) [MR2628852](#) DOI:10.4171/QT/1.
- [KM11] P. B. Kronheimer and T. S. Mrowka. Khovanov homology is an unknot-detector. *Publ. Math. Inst. Hautes Études Sci.*, (113):97–208, 2011. [MR2805599](#) DOI:10.1007/s10240-010-0030-y [arXiv:1005.4346](#).
- [KR08] Mikhail Khovanov and Lev Rozansky. Matrix factorizations and link homology. *Fund. Math.*, 199(1):1–91, 2008. [MR2391017](#) [arXiv:math.QA/0401268](#) DOI:10.4064/fm199-1-1.
- [KV94] M. M. Kapranov and V. A. Voevodsky. 2-categories and Zamolodchikov tetrahedra equations. In *Algebraic groups and their generalizations: quantum and infinite-dimensional methods (University Park, PA, 1991)*, volume 56 of *Proc. Sympos. Pure Math.*, pages 177–259. Amer. Math. Soc., Providence, RI, 1994. [MR1278735](#).
- [Lee05] Eun Soo Lee. An endomorphism of the Khovanov invariant. *Adv. Math.*, 197(2):554–586, 2005. [MR2173845](#) DOI:10.1016/j.aim.2004.10.015 [arXiv:math.GT/0210213](#).

- [Lob09] Andrew Lobb. A slice genus lower bound from \mathfrak{sl}_n Khovanov-Rozansky homology. *Adv. Math.*, 222(4):1220–1276, 2009. [MR2554935](#) [DOI:10.1016/j.aim.2009.06.001](#) [arXiv:math/0702393](#).
- [LQR15] Aaron D. Lauda, Hoel Queffelec, and David E. V. Rose. Khovanov homology is a skew Howe 2-representation of categorified quantum \mathfrak{sl}_m . *Algebr. Geom. Topol.*, 15(5):2517–2608, 2015. [MR3426687](#) [DOI:10.2140/agt.2015.15.2517](#) [arXiv:1212.6076](#).
- [Lur09] Jacob Lurie. On the classification of topological field theories. In *Current developments in mathematics, 2008*, pages 129–280. Int. Press, Somerville, MA, 2009. [MR2555928](#) [arXiv:0905.0465](#).
- [Lus93] George Lusztig. *Introduction to quantum groups*, volume 110 of *Progress in Mathematics*. Birkhäuser Boston Inc., Boston, MA, 1993. [MR1227098](#) [DOI:10.1007/978-0-8176-4717-9](#).
- [Mac99] Marco Mackaay. Spherical 2-categories and 4-manifold invariants. *Adv. Math.*, 143(2):288–348, 1999. [MR1686421](#) [arXiv:math.QA/9805030](#) [DOI:10.1006/aima.1998.1798](#).
- [MSV09] Marco Mackaay, Marko Stošić, and Pedro Vaz. $\mathfrak{sl}(N)$ -link homology ($N \geq 4$) using foams and the Kapustin-Li formula. *Geom. Topol.*, 13(2):1075–1128, 2009. [MR2491657](#) [DOI:10.2140/gt.2009.13.1075](#) [arXiv:0708.2228](#).
- [MV10] Marco Mackaay and Pedro Vaz. The diagrammatic Soergel category and $\mathfrak{sl}(N)$ -foams, for $N \geq 4$. *Int. J. Math. Math. Sci.*, Art. ID 468968, 2010. [MR2671770](#) [DOI:10.1155/2010/468968](#) [arXiv:0911.2485](#).
- [MN20] Ciprian Manolescu and Ikshu Neithalath. Skein lasagna modules for 2-handlebodies. *J. Reine Angew. Math.*, 788:37–76, 2022. [MR4445546](#) [arXiv:2009.08520](#) [DOI:10.1515/crelle-2022-0021](#).
- [MWW2] Ciprian Manolescu, Kevin Walker, and Paul Wedrich. Skein lasagna modules and handle decompositions, 2022. [arXiv:2206.04616](#).
- [MW12] Scott Morrison and Kevin Walker. Blob homology. *Geom. Topol.*, 16(3):1481–1607, 2012. [arXiv:1009.5025](#), [DOI:10.2140/gt.2012.16.1481](#) [MR2978449](#).
- [Prz91] Józef H. Przytycki. Skein modules of 3-manifolds. *Bull. Polish Acad. Sci. Math.*, 39(1-2):91–100, 1991. [MR1194712](#).
- [Qi14] You Qi. Hopfological algebra. *Compos. Math.*, 150(1):1–45, 2014. [MR3164358](#) [DOI:10.1112/S0010437X13007380](#) [arXiv:1205.1814](#).
- [QR16] Hoel Queffelec and David E. V. Rose. The \mathfrak{sl}_n foam 2-category: a combinatorial formulation of Khovanov-Rozansky homology via categorical skew Howe duality. *Adv. Math.*, 302:1251–1339, 2016. [MR3545951](#) [DOI:10.1016/j.aim.2016.07.027](#) [arXiv:1405.5920](#).
- [QR18] Hoel Queffelec and David E. V. Rose. Sutured annular Khovanov-Rozansky homology. *Trans. Amer. Math. Soc.*, 370(2):1285–1319, 2018. [MR3729501](#) [DOI:10.1090/tran/7117](#) [arXiv:1506.08188](#).
- [QS17] You Qi and Joshua Sussan. Categorification at prime roots of unity and hopfological finiteness. In *Categorification and higher representation theory*, volume 683 of *Contemp. Math.*, pages 261–286. Amer. Math. Soc., Providence, RI, 2017. [MR3611717](#) [DOI:10.1090/conm/683](#) [arXiv:1509.00438](#).
- [QS19] Hoel Queffelec and Antonio Sartori. Mixed quantum skew Howe duality and link invariants of type A. *J. Pure Appl. Algebra*, 223(7):2733–2779, 2019. [MR3912946](#) [DOI:10.1016/j.jpaa.2018.09.014](#) [arXiv:1504.01225](#).
- [QW18a] Hoel Queffelec and Paul Wedrich. Extremal weight projectors. *Math. Res. Lett.*, 25(6):1911–1936, 2018. [MR3934851](#) [DOI:10.4310/MRL.2018.v25.n6.a11](#) [arXiv:1701.02316](#).
- [QW21] Hoel Queffelec and Paul Wedrich. Khovanov homology and categorification of skein modules. *Quantum Topol.*, 12(1):129–209, 2021. [MR4233203](#) [DOI:10.4171/QT/148](#) [arXiv:1806.03416](#).
- [Ras10] Jacob Rasmussen. Khovanov homology and the slice genus. *Invent. Math.*, 182(2):419–447, 2010. [MR2729272](#) [DOI:10.1007/s00222-010-0275-6](#) [arXiv:math/0402131](#).
- [Ras15] Jacob Rasmussen. Some differentials on Khovanov–Rozansky homology. *Geom. Topol.*, 19(6):3031–3104, 2015. [MR3447099](#) [DOI:10.2140/gt.2015.19.3031](#) [arXiv:math/0607544](#).
- [Rou08] Raphaël Rouquier. 2-Kac-Moody algebras, 2008. [arXiv:0812.5023](#).
- [Roz10] Lev Rozansky. A categorification of the stable $\mathrm{su}(2)$ Witten-Reshetikhin-Turaev invariant of links in $S^2 \times S^1$, Nov 2010. [arXiv:1011.1958](#).
- [RT90] Nicolai Yu. Reshetikhin and Vladimir G. Turaev. Ribbon graphs and their invariants derived from quantum groups. *Comm. Math. Phys.*, 127(1):1–26, 1990. [MR1036112](#) [euclid.cmp/1104180037](#).
- [RT91] Nicolai Reshetikhin and Vladimir G. Turaev. Invariants of 3-manifolds via link polynomials and quantum groups. *Invent. Math.*, 103(3):547–597, 1991. [MR1091619](#) [euclid.cmp/1104180037](#).
- [RW16] David E.V. Rose and Paul Wedrich. Deformations of colored $\mathfrak{sl}(n)$ link homologies via foams. *Geom. Topol.*, 20(6):3431–3517, 2016. [MR3590355](#) [DOI:10.2140/gt.2016.20.3431](#) [arXiv:1501.02567](#).
- [RW20] Louis-Hadrien Robert and Emmanuel Wagner. A closed formula for the evaluation of foams. *Quantum Topol.*, 11(3):411–487, 2020. [MR4164001](#) [DOI:10.4171/QT/139](#) [arXiv:1702.04140](#).

- [SS06] Paul Seidel and Ivan Smith. A link invariant from the symplectic geometry of nilpotent slices. *Duke Math. J.*, 134(3):453–514, 2006. [MR2254624](#) DOI:10.1215/S0012-7094-06-13432-4 [arXiv:math/0405089](#).
- [Str05] Catharina Stroppel. Categorification of the Temperley-Lieb category, tangles, and cobordisms via projective functors. *Duke Math. J.*, 126(3):547–596, 2005. [MR2120117](#) DOI:10.1215/S0012-7094-04-12634-X.
- [Str09] Catharina Stroppel. Parabolic category \mathcal{O} , perverse sheaves on Grassmannians, Springer fibres and Khovanov homology. *Compos. Math.*, 145(4):954–992, 2009. [MR2521250](#) DOI:10.1112/S0010437X09004035 [arXiv:math/0608234](#).
- [Tau13] Clifford Henry Taubes. Compactness theorems for $SL(2;C)$ generalizations of the 4-dimensional anti-self dual equations, Jul 2013. [arXiv:1307.6447](#).
- [Tau18] Clifford Henry Taubes. Sequences of Nahm pole solutions to the $SU(2)$ Kapustin-Witten equations, May 2018. [arXiv:1805.02773](#).
- [Thu14] Dylan Paul Thurston. Positive basis for surface skein algebras. *Proc. Natl. Acad. Sci. USA*, 111(27):9725–9732, 2014. [MR3263305](#) DOI:10.1073/pnas.1313070111 [arXiv:1310.1959](#).
- [Tur91] Vladimir G. Turaev. Skein quantization of Poisson algebras of loops on surfaces. *Ann. Sci. École Norm. Sup. (4)*, 24(6):635–704, 1991. [MR1142906](#).
- [TVW17] Daniel Tubbenhauer, Pedro Vaz, and Paul Wedrich. Super q -Howe duality and web categories. *Algebr. Geom. Topol.*, 17(6):3703–3749, 2017. [MR3709658](#) DOI:10.2140/agt.2017.17.3703 [arXiv:1504.05069](#).
- [Wal] Kevin Walker. Topological quantum field theories. Available at <http://canyon23.net/math/>.
- [Web17] Ben Webster. Knot invariants and higher representation theory. *Mem. Amer. Math. Soc.*, 250(1191):v+141, 2017. [MR3709726](#) DOI:10.1090/memo/1191 [arXiv:1309.3796](#).
- [Wil21] Michael Willis. Khovanov homology for links in $\#^r(S^2 \times S^1)$. *Michigan Math. J.*, 2021. DOI:10.1307/mmj/1594281620 [arXiv:1812.06584](#).
- [Wit89] Edward Witten. Quantum field theory and the Jones polynomial. *Comm. Math. Phys.*, 121(3):351–399, 1989. [MR990772](#) [euclid.cmp/1104178138](#).
- [Wit12] Edward Witten. Fivebranes and knots. *Quantum Topol.*, 3(1):1–137, 2012. [MR2852941](#) DOI:10.4171/QT/26 [arXiv:1101.3216](#).
- [Wu09] Hao Wu. On the quantum filtration of the Khovanov-Rozansky cohomology. *Adv. Math.*, 221(1):54–139, 2009. [MR2509322](#) DOI:10.1016/j.aim.2008.12.003 [arXiv:math.GT/0612406](#).
- [Wu12] Hao Wu. Equivariant colored $\mathfrak{sl}(N)$ -homology for links. *J. Knot Theory Ramifications*, 21(2):1250012, 104, 2012. [MR3392963](#) DOI:10.1142/S0218216511009558 [arXiv:1002.2662](#).

S.M.: CANBERRA ACT 2602, AUSTRALIA, [TQFT.NET](#)

K.W.: MICROSOFT STATION Q, SANTA BARBARA, CALIFORNIA 93106-6105, USA, [CANYON23.NET/MATH/](#)

P.W.: MATHEMATICAL SCIENCES INSTITUTE, THE AUSTRALIAN NATIONAL UNIVERSITY, HANNA NEUMANN BUILDING, CANBERRA ACT 2601, AUSTRALIA, [PAUL.WEDRICH.AT](#)