

A Lattice Based Joint Encryption, Encoding and Modulation Scheme

Khadijeh Bagheri, Taraneh Eghlidos, Mohammad-Reza Sadeghi, Daniel Panario

Senior Member, IEEE,

Abstract

A new nonlinear Rao-Nam like symmetric key encryption scheme is presented in this paper. QC-LDPC lattices that are practically implementable in high dimensions due to their low complexity encoding and decoding algorithms, are used in our design. Then, a joint scheme is proposed which is capable of encrypting, encoding and data modulation simultaneously. The proposed cryptosystem withstands all variants of chosen plaintext attacks applied on Rao-Nam like cryptosystems due to its nonlinearity. The sparseness of the parity-check matrix of QC-LDPC lattices, quasi-cyclic nature of their generator and parity-check matrices, simple hardware structure for generating intentional error vector, permutation and nonlinear functions, result in a small key size for our scheme. The lattice codes related to the lattices used in this paper have high rate which are suitable for bandlimited AWGN channels. Therefore, the joint scheme based on these lattices facilitates secure, reliable and efficient data transmission in bandlimited AWGN channels.

I. INTRODUCTION

The main objective in large scale and high speed communication networks is the design of a reliable and secure data transmission system. In conventional secure communication systems, channel encoding is used at the physical layer for error correction while encryption is done at a higher layer to make the communication confidential. Nowadays, since many communication devices are constrained in resources or are becoming portable, it is needed to enhance security without increasing computational or hardware complexity. Rao was the first that joined encryption

K. Bagheri and M.-R Sadeghi are with Faculty of Mathematics and Computer Science, Amirkabir University of Technology (Tehran Polytechnic), Tehran, Iran (emails: kbagheri@aut.ac.ir and msadeghi@aut.ac.ir).

T. Eghlidos is with Electronics Research Institute, Sharif University of Technology, Iran (e-mail: teghlidos@sharif.edu).

D. Panario is with School of Mathematics and Statistics, Carleton University, Canada (e-mail: daniel@math.carleton.ca).

Part of this work has been presented in [30].

and error correction (based on a linear block code) in a single step [1] to resolve the issue in an insecure and unreliable channel efficiently. The main purpose of this scheme is to provide both security and reliable data transmission at the same time using a symmetric-key cryptosystem.

Rao defines the proposed cryptosystem based on binary Goppa codes. It is proved that this cryptosystem is not secure against chosen-plaintext attacks. To overcome this weakness, Rao and Nam have introduced a revised symmetric-key cryptosystem [2], [3]. In this paper we use RN to abbreviate Rao and Nam cryptosystem. Struik and Tilburg have generalized the RN scheme to any finite field \mathbb{F}_q [4]. Barbero and Ytrehus have reduced the secret key size of the RN scheme, while maintaining the security level of the system [5]. The previous proposed RN-like schemes have very large key size or low information rate that makes them impractical. Several schemes have been presented in the literature to modify RN, reduce the key size, increase information rate and improve security against known attacks. Some of them use quasi-cyclic (QC) codes to reduce the key size and use low-density parity-check (LDPC) codes to increase the information rate [6], [7]. Unlike the previous RN-like schemes that scramble, permute or change the codeword bits, the proposed joint schemes based on QC-LDPC codes in [8], [9] and [10], randomly puncture the codeword corresponding to a plaintext. The security and the key sizes of these schemes have been significantly improved. Another joint scheme has been proposed based on low-density lattice codes (LDLCs) [11] that has practical decoder [12].

All of these RN-like schemes are vulnerable to the message-resent attack [13]. It is an interesting idea to consider nonlinear layers for RN-like schemes to provide their resistance against well known chosen plaintext attacks. The RN-like schemes, named SECC (secret error-correcting codes), use nonlinear codes, or block chaining technique to withstand against the chosen plaintext attacks, while retaining the error correction performance [14]. ECBC (Error Correction Based Cipher) is another RN-like scheme that uses a nonlinear function f in its structure [15]. In parallel, a differential-style attack (chosen-plaintext attack) against ECBC and SECC has been proposed in [16]. It is shown that the non-linear function f used in ECBC is particularly vulnerable to this attack and its secret key is recovered in constant time. The security of [14] and [15] is enhanced to resist the differential attack proposed in [16] by considering a special design for the nonlinear function f [17]. The authors claim that the proposed scheme is the most efficient secure channel coding scheme among the previous code based schemes [17].

There is another approach for joining encryption and encoding in a single step. The proposed schemes in this approach use error correcting codes as a replacement of the AES (Advanced

Encryption Standard) diffusion layer [18], [19]. The message-resend attack [13] is not effective on these joint AES-coding schemes. In spite of providing error correction, small key size (equal to AES) and data security against linear and differential attacks, these schemes suffer from higher computational complexities compared to RN-like schemes.

In the RN-like schemes, the security is embedded in the channel code to enhance the security of the entire system. They are fast and easy from an implementation standpoint. The earlier RN-like schemes have smaller error correction capability than error correction codes. Indeed, to achieve significant error correction capacity, the schemes' parameters have to be large which lead to large key size and high computational complexity. However, this issue has been resolved in recent RN-like schemes [17]. Low power consumption for RN-like schemes is an important advantage that leads us to concentrate on RN-like schemes. This allows us to use the same hardware components for error correction and security.

In the conventional joint schemes, modulation is applied on the resulting point that is sent to the channel. In this paper, we propose an alternative secure wireless communication model that uses a coded-modulation scheme based on lattices to design an RN-like scheme to merge encryption, channel encoding and modulation in a single step. Using lattices in designing RN-like schemes is rare due to the high complexity of lattice encoding and decoding even for legitimate users. We use a special type of lattices that provide proper efficiency for the proposed scheme.

In general, a digital modulator is used at the output of the channel encoder, which serves as an interface to the communication channels. The modulator produces signal waveforms that transmit information. When treating a channel coding as a separate operation independent of modulation, the coded sequences generally have a smaller channel symbol duration than the uncoded sequences for the same information rate. Accordingly, the power spectral density (PSD) of the channel signals changes essentially. On the other hand, if the modulation is designed in conjunction with the channel coding, error correction can be achieved without leading to any essential changes in the PSD. The advantages of the coded-modulation schemes, that are the schemes in which coding and modulation are combined, are highlighted here. This importance is featured more when designing coding techniques for high-SNR (signal to noise ratio) regimes or bandlimited channels [20]. Therefore, our goal is to use a proper coded-modulation scheme in our cryptosystem to provide a secure communication for high-SNR or bandlimited channels.

Based on Shannon's capacity theorem, an optimal block code for a bandlimited additive white Gaussian noise (AWGN) channel consists of a dense packing of the code points within a sphere

in a high-dimensional Euclidean space. Lattices and trellis codes are two main categories of packings, for moderate coding gains at moderate complexity [21]. Lattices are most of the densest known packings. Construction-A of lattices [22] are not among the densest packings but define a natural mapping from codewords of the underlying code to lattice points in the Euclidean space. Thus, they are coded-modulation schemes.

A lattice code is defined by a lattice Λ and a shaping region $B \subset \mathbb{R}^n$, where its codewords are all the lattice points that belong to the shaping region B . Lattice codes are a suitable coded-modulation scheme on bandlimited (high-SNR) AWGN channels [21]. In this paper, we use a lattice code of some kind of construction-A lattices.

LDPC lattices are the first family of modern lattices [23], [24] with practical decoding algorithms in high dimensions [25]. It has been shown that these lattices can achieve desirable performance when compared to other modern lattices [26]. A special sub-class of LDPC lattices, QC-LDPC lattices, is a construction-A lattices that have practical encoder as well [27]. Due to the easy construction, linear encoding and decoding complexity and good error performance of the QC-LDPC lattices, their lattice codes have the potential to become a practical and efficient coding scheme for the AWGN channel. Furthermore, QC-LDPC lattices have many applications in the wireless communications [28], [29], as well as in designing symmetric and asymmetric key encryption schemes [30], [31].

In this paper, we exploit the characteristics of QC-LDPC lattice codes and the efficiency of this coded-modulations to merge encryption, channel encoding and modulation in a single step. Due to the hardware reuse, such scheme improves the transmission efficiency, reduces the system processing delay and saves in hardware usage. More flexibility in terms of design and technology used for the construction is given, as well. The sparse nature of the parity-check matrix of the QC-LDPC lattices can be exploited to reduce the key size. Moreover, good error performance and linear encoding and decoding (time and space) complexities (in terms of the lattice dimension) of these lattice codes provide an efficient joint scheme that is suitable for secure communication in bandlimited (high-SNR) AWGN channels.

This paper is organized as follows. In Section II, we present some lattice notation used in this paper. In Section III, a symmetric key encryption scheme based on QC-LDPC lattices is presented. We describe a joint encryption, encoding and modulation scheme based on these lattices in Section IV. In Section V, we give details about the key sizes, computational complexity of encryption and decryption. Section VI is devoted to the security analysis and numerical results

related to the security of our scheme against different attacks. The comparison with other RN-like schemes and a summary of the paper are given in Section VII and Section VIII, respectively.

II. PRELIMINARIES

A. Construction of Lattices from Codes

Let \mathbb{R}^m be the m -dimensional real vector space with Euclidean norm. An n -dimensional *lattice* is a discrete additive subgroup of \mathbb{R}^m that is presented by the set of all integer linear combinations of a given basis of n linearly independent vectors in \mathbb{R}^m [22]. Let $\mathbf{b}_1, \mathbf{b}_2, \dots, \mathbf{b}_n \in \mathbb{R}^m$, be the basis vectors of the lattice Λ . The *generator matrix* for the lattice is the matrix \mathbf{B} , where \mathbf{b}_i is its i -th row. Therefore, the lattice Λ is defined as $\Lambda = \{\boldsymbol{\xi} \cdot \mathbf{B} \mid \boldsymbol{\xi} \in \mathbb{Z}^n\}$. If $m = n$, the lattice is *full rank*. For more details about lattices and their properties, see [22].

There are many ways to construct lattices from linear codes; many properties of such lattices can be related to the properties of their underlying codes [22]. In our work Construction-A of lattices is used that are explained in the sequel.

Let $C = C[n, k] \subseteq \mathbb{Z}_p^n$ be a linear code with dimension k and length n , where p is a prime number. A lattice Λ constructed from the code C based on Construction-A is defined by

$$\Lambda = p\mathbb{Z}^n + \phi(C) = \{p\mathbf{z} + \phi(\mathbf{c}) : \mathbf{c} \in C, \mathbf{z} \in \mathbb{Z}^n\},$$

where $\phi: \mathbb{Z}_p^n \rightarrow \mathbb{R}^n$ is the embedding function which maps a vector in \mathbb{Z}_p^n to its real version [22]. Indeed, Construction-A is a method for generating a lattice by “lifting” a linear code C to the Euclidean space. In this paper, we use binary linear codes and lattices with $p = 2$. We consider a subclass of LDPC lattices [24] that can be obtained from Construction-A [32]. It is interesting to focus on the quasi-cyclic (QC) version of these lattices for cryptographic purposes.

Definition 2.1: Let $C = C[n, k]$ be a binary linear QC-LDPC code. A *QC-LDPC lattice* Λ is a lattice based on Construction-A along with a binary linear QC-LDPC code C which is defined as $\Lambda = \{\mathbf{x} \in \mathbb{Z}^n \mid \mathbf{H}_{qc} \cdot \mathbf{x}^T \equiv \mathbf{0} \pmod{2}\}$, where \mathbf{H}_{qc} is the parity-check matrix of C [27].

The generator matrix of a QC-LDPC lattice Λ is the following $n \times n$ matrix

$$\mathbf{G}_\Lambda = \begin{bmatrix} \mathbf{I}_k & \mathbf{A}_{k \times (n-k)} \\ \mathbf{0}_{(n-k) \times k} & 2\mathbf{I}_{n-k} \end{bmatrix} = \begin{bmatrix} \mathbf{G}_C & \\ \mathbf{0}_{(n-k) \times k} & 2\mathbf{I}_{n-k} \end{bmatrix}, \quad (1)$$

where $\mathbf{0}$ stands for the zero block, \mathbf{I} for an identity block and $\mathbf{G}_C = \left[\mathbf{I}_k \quad \mathbf{A}_{k \times (n-k)} \right]_{k \times n}$ is the systematic form of the generator matrix of C [26].

1) *Encoding of QC-LDPC lattices:* Based on a method for encoding Construction-A lattices in [22], the encoding of LDPC lattices is introduced in [26] as follows. In order to find a decoding method for these family of lattices, a translated sublattice of lattice Λ , generated by (1), is considered. First, the codewords' components of the binary code C are converted into ± 1 , that is, 0 is converted to -1 and 1 is converted to 1. Then, the set $\Lambda(C) = \{\mathbf{c} + 4\mathbf{z} \mid \mathbf{c} \in C, \mathbf{z} \in \mathbb{Z}^n\}$, where C is a QC-LDPC code with ± 1 components, is a lattice which is closed under the addition $\lambda_1 \oplus \lambda_2 \triangleq \lambda_1 + \lambda_2 + (1, \dots, 1)$, for all $\lambda_1, \lambda_2 \in \Lambda(C)$. Therefore, the encoding algorithm of sublattice $\Lambda(C)$ for any integer row vector $\boldsymbol{\xi} \in \mathbb{Z}^n$ can be done with the generator matrix (1) as $E(\boldsymbol{\xi}) = 2\boldsymbol{\xi} \cdot \mathbf{G}_\Lambda - \mathbf{1}$, where $\mathbf{1} = (1, \dots, 1)$, E is the encoding function and $E(\boldsymbol{\xi})$ is a point of the lattice $\Lambda(C)$ [26]. Let the points of the lattice $\Lambda(C)$ be transmitted over an unconstrained AWGN channel with noise variance σ^2 . Then, its volume-to-noise ratio is defined as $\text{VNR} = \frac{4^{(2n-k)/n}}{2\pi e \sigma^2}$.

2) *Decoding of QC-LDPC lattices:* Let $\mathbf{x} = \mathbf{c} + 4\mathbf{z}$ be the transmitted lattice vector of $\Lambda(C)$ and $\mathbf{y} = \mathbf{c} + 4\mathbf{z} + \mathbf{n}$ be the received vector from the AWGN channel, where $\mathbf{n} \sim \mathcal{N}(0, \sigma^2)$. A soft decision message passing algorithm, that is sum-product algorithm (SPA), is presented in [27] for decoding QC-LDPC lattices that has low implementation complexity and memory requirements. These lattices can be decoded in linear time complexity in terms of dimension.

B. RDF-QC-LDPC codes

To have efficient decoding and good performance for QC-LDPC codes, their parity-check matrix should be free of length-4 cycles.

In this paper, we consider QC-LDPC codes with rate $R = (n_0 - 1)/n_0$ with parity-check matrix described by

$$\mathbf{H}_{qc} = \left[\mathbf{H}_0 \mid \mathbf{H}_1 \mid \cdots \mid \mathbf{H}_{n_0-1} \right], \quad (2)$$

where $\mathbf{H}_0, \dots, \mathbf{H}_{n_0-1}$ are $b \times b$ circulant matrices and have low row/column Hamming weight.

Some algebraic approaches for code design are possible with this particular form of the parity-check matrix. However, some of them impose constraints on the code length. The proposed techniques based on *Difference Families* (DFs) such as *Extended Difference Families* (EDFs) and *Random Difference Families* (RDFs), loosen the constraints using computer aided procedures [33].

Using these techniques and given the number of circulant blocks n_0 with column weight d_v , the size of the circulant matrices, b , is chosen to ensure the absence of length-4 cycles in the associated code [33].

For $d_v = 5$ and $n_0 = 8$, the size of circulant matrices is $b = 187$ by the RDF construction technique [33]. Therefore, the RDF-QC-LDPC code with these parameters (d_v and n_0) has code length 1496, dimension 1309, rate $R = 7/8$ and row weight $d_c = 40$ [33]. However, using the same parameters, the size of the circulant matrix for the EDF-based solution is $b > 200$. The minimum length of QC-LDPC code based on EDF technique for $d_v = 5$ and $n_0 = 8$ is 1600 [33]. Hence, the RDF-based approach allows to design shorter codes compared to those designed through the EDF approach.

Simulation results of symbol error rate (SER) versus VNR of QC-LDPC lattices based on EDF and RDF over the AWGN channel are presented in Fig. 1. According to the results of this figure, RDF based QC-LDPC lattices outperform EDF based QC-LDPC lattices in smaller dimensions. For example, in $\text{SER} = 10^{-5}$, an RDF based QC-LDPC lattice with parameters $(k, n) = (1309, 1496)$, $d_v = 5$ and $n_0 = 8$ has 0.05dB better performance compared to an EDF based QC-LDPC lattice with $(k, n) = (1407, 1608)$, $d_v = 5$ and $n_0 = 8$.

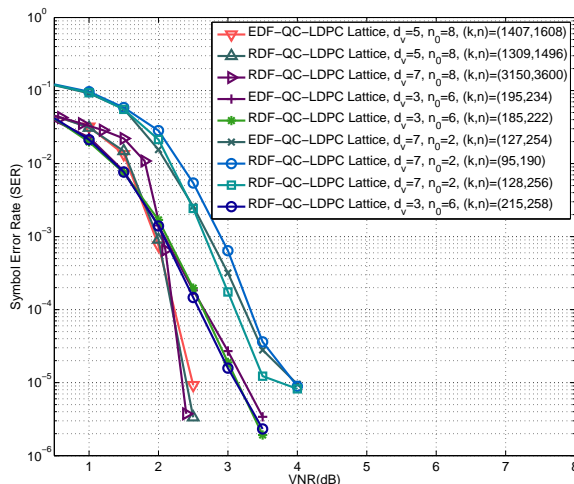

Fig. 1. Error performance of EDF and RDF based QC-LDPC lattices.

The results of Fig. 1 also show that by using underlying codes with higher rates and increasing the n_0 value, which results in a decrease of d_v value, we gain a considerable performance improvement. For example, in the SER of 10^{-5} , using an RDF based QC-LDPC lattice with $(k, n) = (215, 258)$, $d_v = 3$, $n_0 = 6$ gives us 0.5dB performance improvement compared to the same dimension RDF based QC-LDPC lattice with $(k, n) = (128, 256)$, $d_v = 7$, $n_0 = 2$.

Interesting aspects of the design technique based on RDFs, which is important for cryptographic applications, are generating a large number of equivalent codes with the same code

length, dimension and column weight, as well as designing shorter codes compared to those designed based on DFs and EDFs approaches. All these good features and the easy construction of RDF-QC-LDPC codes lead us to use them as the underlying codes used in our lattices.

In the rest of this paper, whenever we use a QC-LDPC lattice, we mean that the lattice is constructed using an RDF QC-LDPC code as its underlying code.

III. SYMMETRIC KEY CRYPTOSYSTEM BASED ON QC-LDPC LATTICES

In this work, we design a new symmetric key encryption scheme using a special type of lattices, namely QC-LDPC lattices. Defining an appropriate nonlinear function, we enhance the security of the cryptosystem against chosen plaintext attack, differential or linear type attacks. We adapt the method presented in [38] to design an invertible nonlinear mapping F for our encryption scheme where all the operations are performed over the field of real numbers \mathbb{R} .

In the structure of this mapping, we use some $n \times n$ linear transformations represented by an $n \times n$ binary matrix. We construct the transformation matrices using a companion matrix of a primitive polynomial in $\mathbb{F}_2[x]$ described as follows. The linear transformations corresponding to these invertible matrices are represented by the linear operators F_0, \dots, F_{2^d-1} , for an integer number $d > 0$. The input vector of the mapping F is $\mathbf{z} = (\mathbf{a}, \mathbf{b})$, where \mathbf{a} is an n -tuple vector and \mathbf{b} is a d -tuple binary vector. The input to each linear transformation is an n -tuple vector \mathbf{a} in which $a_i \in \mathbb{Z}$, for $i = 0, \dots, n-1$. Each linear operator F_j , for $j = 0, \dots, 2^d - 1$, transforms an n -tuple input to an n -tuple output. Then, the output of the linear transformations are passed through a multiplexer, controlled by the d -tuple vector \mathbf{b} which serves as the control line. Indeed, the control line of the multiplexer is used to select one of the outputs of the linear transformations. The overall structure of the mapping is shown in Fig. 2.

In this paper, we construct the corresponding matrices for the linear transformations used in the architecture of F based on the following mathematical method. In this architecture, the applied linear transformations need to have maximal period. Indeed, the corresponding matrix \mathbf{U} should have maximal order, that is, $\mathbf{U}^{2^n-1} = \mathbf{I}$, where \mathbf{I} is the $n \times n$ identity matrix, and $\mathbf{U}^m \neq \mathbf{I}$, for $m < 2^n - 1$.

Let $g \in \mathbb{F}_q[x]$ be a nonzero polynomial of degree $n \geq 1$. If $g(0) \neq 0$, the order of g is the least positive integer e , $1 \leq e \leq q^n - 1$, such that $g(x)|x^e - 1$ and it is denoted by $ord(g)$ [34]. It is known that the order of a primitive polynomial g of degree n is equal to $q^n - 1$. Let

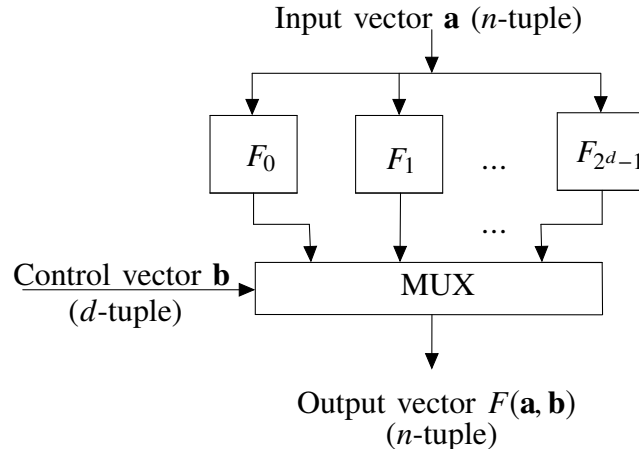

Fig. 2. The structure of nonlinear mapping F .

$g(x) = x^n + a_{n-1}x^{n-1} + \dots + a_1x + a_0$, where $a_0 \neq 0$, Then, $C(g)$ is the companion matrix of g as

$$C(g) = \begin{bmatrix} 0 & 1 & 0 & \cdots & 0 \\ 0 & 0 & 1 & \cdots & 0 \\ \vdots & \vdots & \vdots & \ddots & \vdots \\ 0 & 0 & 0 & \cdots & 1 \\ -a_0 & -a_1 & -a_2 & \cdots & -a_{n-1} \end{bmatrix}_{n \times n} .$$

Since $\det(C(g)) = (-1)^n a_0$ and $g(0) = a_0 \neq 0$, the companion matrix of g is an invertible matrix, that is, $C(g) \in GL_n(q)$ [35]. Furthermore, the order of the polynomial g is related to the order of companion matrix [35]. It can be verified that the order of $C(g)$ as an element of $GL_n(q)$ is equal to the order of g . It can be shown that the inverse of a companion matrix of the polynomial $g(x) = x^n + a_{n-1}x^{n-1} + a_{n-2}x^{n-2} + \dots + a_1x + a_0$ is a companion matrix of the polynomial $r(x) = x^n + \frac{a_1}{a_0}x^{n-1} + \frac{a_2}{a_0}x^{n-2} + \dots + \frac{a_{n-1}}{a_0}x + \frac{1}{a_0}$.

Let us consider a primitive polynomial $g \in \mathbb{F}_2[x]$ of degree n with $g(0) \neq 0$. Therefore, the order of its corresponding companion matrix satisfies $ord(C(g)) = ord(g) = 2^n - 1$ and $\det(C(g)) = (-1)^n$. We use this companion matrix $C(g)$ that is a binary low dense matrix of maximum order $2^n - 1$ to construct a nonlinear function F for our proposed scheme. For simplicity we write $C(g) = \mathbf{U}$ in the sequel. Then, the set $S = \{\mathbf{I}, \mathbf{U}, \mathbf{U}^2, \dots, \mathbf{U}^{2^n-2}\}$ contains $2^n - 1$ invertible binary matrices of dimension $n \times n$.

The mapping F is obtained using 2^d linear transformations from the set S indicated by the linear transformations F_0, \dots, F_{2^d-1} . As a consequence, $F : \mathbb{Z}^{n+d} \rightarrow \mathbb{Z}^n$ is a mapping defined by $F(\mathbf{a}, \mathbf{b}) = F_\alpha(\mathbf{a}) = \mathbf{a}\mathbf{U}^\alpha$, where $\alpha = \sum_{i=0}^{d-1} b_i 2^i \in \{0, 1, \dots, 2^d - 1\}$ is determined by the vector

\mathbf{b} as the control line of the multiplexer. The public set S and a secret control line \mathbf{b} of the multiplexer define this function. On the other hand, the output $F(\mathbf{a}, \mathbf{b}) = \{f_1(\mathbf{a}, \mathbf{b}), \dots, f_n(\mathbf{a}, \mathbf{b})\}$ is the concatenation of the output of 2^d linear operators selected according to the logic of multiplexer [38]. Each component function can be written mathematically as

$$f_i(\mathbf{a}, \mathbf{b}) \equiv \bigoplus_{j=0}^{2^d-1} D_j(\mathbf{b}) \mathbf{u}_{ji}(\mathbf{a}) \pmod{2}, \quad (3)$$

where \mathbf{u}_{ji} is the i th row of the matrix \mathbf{U}^j , and $D_j(\cdot)$ is a function defined as $D_j(\mathbf{b}) = D_\sigma(\mathbf{b}) = (\bar{i}_1 \oplus b_1) \cdots (\bar{i}_d \oplus b_d)$ over $\sigma = (i_1, \dots, i_d)$ which is the binary representation of j and \bar{v} is the complement of v . In a similar way [38], it can be proved that the algebraic degree of each component function of the proposed mapping F and their nonzero linear combinations is $d + 1$.

A. Key generation

Encryption is done using the following secret keys that are chosen by the authorized transmitter and receiver.

- 1) A random regular $(n = n_0 b, k = (n_0 - 1)b, d_c)$ -QC-LDPC code constructed from RDFs with a parity-check matrix of size $(n - k) \times n$ in the form of (2) and constant row weight d_c . This RDF-QC-LDPC code with the parity-check matrix \mathbf{H}_{q_c} is used to construct a QC-LDPC lattice (according to the previous section).
- 2) A vector \mathbf{s} as l_1 -bit initial value (seed) of a linear feedback shift register (LFSR) which is described using a polynomial q . We use this LFSR to produce an n -tuple intentional error vector \mathbf{e} in the scheme. For reducing the key size and increasing the period of the resultant keystream, we use a reseeding mechanism for this LFSR at the end of each period. This mechanism uses the modular division circuit with a different polynomial p for another LFSR of the same length proposed in [37]. With a proper selection of the polynomials q and p , the period of the LFSR is equal to $(2^{l_1} - 1)^2$. Since, the output of each period of the LFSR is a vector with approximately $(2^{l_1} - 1)$ bits, then the length of the LFSR should be selected in such a way that the message length n is close to the period of LFSR, that is, $(2^{l_1} - 1) \approx n$. Therefore, we consider $l_1 = \lceil \log_2 n \rceil$ which implies $(2^{l_1} - 1)^2 \approx n^2$. Using this procedure, we can produce n different pseudorandom binary vectors $\mathbf{e}_i, i = 1, \dots, n$, of length n for the encryption algorithm.
- 3) An $n \times n$ block diagonal permutation matrix $\mathbf{P} = \text{diag}(\pi_1, \dots, \pi_v)$ formed by $q \times q$ sub-matrices π_i , for $i = 1, \dots, v$, where $v = n/q$. The diagonal elements π_i 's are permutation sub-matrices, so the Hamming weight of each row and column is one. We control $q \times$

q sub-matrices π_i , for $i = 1, \dots, v$, by v different initial values for an LFSR of length $\lceil \log_2 q \rceil$. We describe it in Section V-C. Since, the sub-matrices π_i s are saved instead of the permutation matrix \mathbf{P} , it is needed to save only the corresponding initial value of the LFSR. We concatenate these initial values and store them in a vector \mathbf{t} of length $l_4 = v \lceil \log_2 q \rceil$ bits as a key.

- 4) An l_2 -bit initial vector \mathbf{h} of an LFSR that controls the multiplexer in the construction of the nonlinear mapping F . The vector \mathbf{h} serves as the control line and the multiplexer outputs one of the outputs of the linear transformations according to this control line.

Let d_v denote the number of nonzero elements in each row/column of \mathbf{H}_i in \mathbf{H}_{qc} , thus the row weight of \mathbf{H}_{qc} is $d_c = n_0 d_v$. Let \mathbf{H}_{n_0-1} be non-singular, particularly, this implies that d_v is odd. Then, the systematic generator matrix of this QC-LDPC code is

$$\mathbf{G}_C = \left[\begin{array}{c|c} & \begin{array}{c} (\mathbf{H}_{n_0-1}^{-1} \mathbf{H}_0)^T \\ (\mathbf{H}_{n_0-1}^{-1} \mathbf{H}_1)^T \\ \vdots \\ (\mathbf{H}_{n_0-1}^{-1} \mathbf{H}_{n_0-2})^T \end{array} \\ \mathbf{I}_k & \end{array} \right]_{k \times n}, \quad (4)$$

where $[\cdot]^T$ denotes the transposition operation. Then, the generator matrix \mathbf{G}_Λ of the corresponding QC-LDPC lattice is obtained by replacing it in Eq. (1).

Since each circulant matrix \mathbf{H}_i , for $i = 0, \dots, n_0 - 1$, is completely described by its first row, the QC-LDPC code with parity-check matrix (2) is given by the first row of these circulant blocks. Therefore, we save the first row of \mathbf{H}_{qc} instead of the entire matrix.

B. Encryption Algorithm

To encrypt a message $\mathbf{m} \in \mathbb{Z}^n$, an intentional pseudorandom error vector $\mathbf{e} \in \mathbb{F}_2^n$ is generated using the LFSR with the secret initial value \mathbf{s} and the reseeding mechanism. This error vector of length n has an arbitrary Hamming weight. Then, the ciphertext is computed as follows

$$\begin{aligned} \mathbf{y} &= \left(2F((\mathbf{m} + \bar{\mathbf{e}}), \mathbf{h}) \mathbf{G}_\Lambda - \mathbf{1} + 2\mathbf{e} \right) \mathbf{P} \\ &= \left(2\mathbf{x} \mathbf{G}_\Lambda - \mathbf{1} + 2\mathbf{e} \right) \mathbf{P}, \end{aligned}$$

where $\bar{\mathbf{e}}$ is the complement of the vector \mathbf{e} in \mathbb{F}_2 . The nonlinear function F maps the intentionally corrupted message $(\mathbf{m} + \bar{\mathbf{e}})$ to the vector $\mathbf{x} = F((\mathbf{m} + \bar{\mathbf{e}}), \mathbf{h}) = (\mathbf{m} + \bar{\mathbf{e}}) \mathbf{U}^\alpha$, in which $\alpha = \sum_{i=0}^{d-1} h_i 2^i$ and \mathbf{h} is the secret control line of the employed multiplexer in F . Indeed, the ciphertext \mathbf{y} is the permutation of the lattice point $\tilde{\lambda} = 2\mathbf{x} \mathbf{G}_\Lambda - \mathbf{1}$ which has been perturbed by the vector $2\mathbf{e}$.

In general, the j th instance of the ciphertext \mathbf{y}_j ($j \geq 1$) corresponds to the j th instance of the plaintext \mathbf{m}_j as follows

$$\mathbf{y}_j = \left(2F((\mathbf{m}_j + \bar{\mathbf{e}}_{(j)N_e}), \mathbf{h}_{(j)N_h}) \mathbf{G}_\Lambda - \mathbf{1} + 2\mathbf{e}_{(j)N_e} \right) \mathbf{P}_{(j)N_p},$$

where $(j)_N$ is considered as $j \bmod N$. The numbers N_e, N_h and N_p express the total possibilities of the intentional error vector \mathbf{e} , the multiplexer select logic \mathbf{h} and the permutation matrix \mathbf{P} , respectively. Indeed, the vectors \mathbf{e} and \mathbf{h} and the permutation matrix \mathbf{P} are changed corresponding to the output of the used LFSRs in their producing process. For simplicity, in the following, we ignore their subscripts.

As each lattice point $\tilde{\boldsymbol{\lambda}} = 2\mathbf{x}\mathbf{G}_\Lambda - \mathbf{1}$ is a vector with odd components, we must add $2\mathbf{e}$ instead of \mathbf{e} as intentional error vector in the encryption process. Otherwise, $2\mathbf{x}\mathbf{G}_\Lambda - \mathbf{1} + \mathbf{e}$ is a vector with some even components that reveals the perturbed positions. Moreover, based on Section II-A1, each lattice point in $\Lambda(C)$ can be expressed as a vector of the form $\mathbf{c} + 4\mathbf{z}$, where $\mathbf{c} \in C$ (converted into ± 1) and $\mathbf{z} \in \mathbb{Z}^n$. When we add the vector $2\mathbf{e}$ to a lattice point in the encryption process, we get

$$\mathbf{c} + 4\mathbf{z} + 2\mathbf{e} = \mathbf{c}' + 4\mathbf{z}',$$

where \mathbf{c}' is a vector with components ± 1 and $\mathbf{z}' \in \mathbb{Z}^n$. Hence, $\tilde{\boldsymbol{\lambda}} + 2\mathbf{e}$ is another lattice point that gives no information about the intentional error vector \mathbf{e} .

C. Decryption Algorithm

For decryption, the authorized receiver must be aware of the intentional error vector \mathbf{e} that the transmitter uses by encrypting each plaintext. In addition, both the authorized receiver and transmitter need to use the same LFSR with the same seed \mathbf{s} as a part of the secret key. Therefore, if they use the modular division circuit for generating the pseudorandom error vector \mathbf{e} simultaneously, they can use the same error vector \mathbf{e} for encryption and decryption. Hence, the decryption is done by employing the following steps:

- 1) Multiply the ciphertext \mathbf{y} by $\mathbf{P}^{-1} = \mathbf{P}^T$ and get

$$\mathbf{y}' = \mathbf{y}\mathbf{P}^T = 2\mathbf{x}\mathbf{G}_\Lambda - \mathbf{1} + 2\mathbf{e}.$$

- 2) Subtract $2\mathbf{e}$ from \mathbf{y}' to get $2\mathbf{x}\mathbf{G}_\Lambda - \mathbf{1}$.

- 3) Recover the vector $\mathbf{x} = F((\mathbf{m} + \bar{\mathbf{e}}), \mathbf{h})$ by adding the vector $\mathbf{1}$ to $\mathbf{y}' - 2\mathbf{e}$ and multiplying the result by $\frac{1}{2}\mathbf{G}_\Lambda^{-1}$, where

$$\mathbf{G}_\Lambda^{-1} = \begin{bmatrix} \mathbf{I}_k & -\frac{1}{2}\mathbf{A}_{k \times (n-k)} \\ \mathbf{0}_{(n-k) \times k} & \frac{1}{2}\mathbf{I}_{(n-k)} \end{bmatrix}.$$

- 4) Apply the inverse of the function F on \mathbf{x} using the secret vector \mathbf{h} and recover the intentionally corrupted message vector $\mathbf{m}' = \mathbf{m} + \bar{\mathbf{e}}$.
- 5) Retrieve the original message \mathbf{m} by computing $\mathbf{m}' - \bar{\mathbf{e}}$.

We can use this system for communication in which the ciphertext is transmitted over a noisy channel. This entails some modifications to our cryptosystem to present a joint scheme that can process encryption, channel coding and modulation in a single step which is discussed in the next section.

IV. THE PROPOSED JOINT ENCRYPTION, CHANNEL CODING AND MODULATION SCHEME

In this section, we use QC-LDPC lattices to introduce a joint scheme to provide secure communication over bandwidth-limited (high-SNR) AWGN channels.

For communications over a noisy power constrained AWGN channel, the encoding operation must be accompanied by a shaping method. This prevents the transmission power of a codeword from being unnecessarily increased. Indeed, we make sure that only lattice points that belong to a shaping region are actually used. Then, instead of mapping the message vector \mathbf{m} to the lattice point $\mathbf{m}\mathbf{G}_\Lambda$ in Λ , it should be mapped to another lattice point $\mathbf{m}'\mathbf{G}_\Lambda$, belonging to the shaping region.

Some known shaping methods in the literature are hypercube shaping, Voronoi shaping and spherical shaping. In theoretical approaches, the infinite lattice is intersected with a spherical shaping to produce a power-constrained lattice code. Due to the high computational complexity of this shaping, we consider an efficient hypercube shaping algorithm that has minimum complexity among other shaping methods for QC-LDPC lattices to obtain finite lattice constellations [28].

Thus, we choose a signal constellation formed by a QC-LDPC lattice together with a hypercube shaping region for process of the mapping. Indeed, each message is modulated to one of the constellation points using QC-LDPC lattice encoding and a suitable shaping method.

A. The Proposed Encryption Algorithm

The ciphertext of the proposed symmetric key encryption scheme is in the following form:

$$\mathbf{y} = \left(2F((\mathbf{m} + \bar{\mathbf{e}}), \mathbf{h})\mathbf{G}_\Lambda - \mathbf{1} + 2\mathbf{e} \right) \mathbf{P}. \quad (5)$$

All operations, such as applying the function F on $\mathbf{m}' = \mathbf{m} + \bar{\mathbf{e}}$ and computing the lattice point $\tilde{\mathbf{x}} = 2\mathbf{x}\mathbf{G}_\Lambda - \mathbf{1}$, and so on, are computed over the real numbers \mathbb{R} . Therefore, the resulting ciphertext \mathbf{y} may have large components, even if we restrict the message components. While transmitting

the ciphertext over a noisy power constrained AWGN channel, the encrypting operation must be accompanied by a shaping method. In this way, the vector $\tilde{\boldsymbol{\lambda}}$ is limited to a region around the origin that leads to the reduction of ciphertext transmission power.

On the other hand, the matrices \mathbf{U}^i 's ($i = 0, \dots, 2^n - 2$) in the set S have no structure and may be dense enough. We have observed that some columns in \mathbf{U}^i 's are all one vectors. Therefore, even by applying a shaping method on $\mathbf{x} = F(\mathbf{m}', \mathbf{h}) = \mathbf{m}'\mathbf{U}^\alpha$, where $\alpha = \sum_{i=0}^{d-1} h_i 2^i$, the vector \mathbf{x} may be mapped into a big hypercube with high complexity. Thus, we restrict the components of the input integer vector \mathbf{m} to the following finite constellation before shaping:

$$\begin{aligned} m_{2i} &\in \{x \in \mathbb{Z} \mid -L_i \leq x \leq -1\}, \quad i = 1, \dots, n/2, \\ m_{2i-1} &\in \{x \in \mathbb{Z} \mid 0 \leq x \leq L_i - 1\}, \quad i = 1, \dots, n/2, \end{aligned} \quad (6)$$

where L_i 's are positive integers. In this way, $-L_i \leq m'_{2i} \leq 0$ and $0 \leq m'_{2i-1} \leq L_i$, for $i = 1, \dots, \frac{n}{2}$. Therefore, the vector \mathbf{x} in the worst case lies in an n -dimensional hypercube around the origin such that $x_i \in \{x \in \mathbb{Z} \mid -\frac{n}{2}L_i \leq x \leq \frac{n}{2}L_i\}$.

In our proposed scheme, it is desirable to design an optimal finite constellation for the entries of \mathbf{m} such that the sizes of the entries of $\mathbf{x} = \mathbf{m}'\mathbf{U}^\alpha$ become as small as possible. Designing such constellation could be an interesting problem for future work.

In the next step, we compute the lattice point $\boldsymbol{\lambda} = \mathbf{x}\mathbf{G}_\Lambda$ in the encryption process. Since all operations are performed over real numbers, the entries of $\mathbf{x}\mathbf{G}_\Lambda$ can also be large. Therefore, to make the scheme practical, we use a hypercube shaping method to keep the corresponding entries of the ciphertext vector as small as possible. Indeed, instead of mapping the vector \mathbf{x} to the lattice point $\boldsymbol{\lambda} = \mathbf{x}\mathbf{G}_\Lambda$ in the infinite lattice Λ , it is mapped to a lattice point $\boldsymbol{\lambda}' = \mathbf{x}'\mathbf{G}_\Lambda$ inside an n -dimensional hypercube such that $|\lambda'_i| \leq nL_i - 1$, for $i = 1, \dots, n$.

In the first step we enforce that $-\frac{n}{2}L_i \leq x_i \leq \frac{n}{2}L_i$, for $i = 1, \dots, n$. Therefore, the needed restriction condition of the input vector to a finite constellation for the shaping algorithm is satisfied. Thus, we consider a new lattice point

$$\boldsymbol{\lambda}' = \mathbf{x}'\mathbf{G}_\Lambda = (\mathbf{x} - \mathbf{z}\mathbf{L})\mathbf{G}_\Lambda, \quad (7)$$

instead of $\boldsymbol{\lambda} = \mathbf{x}\mathbf{G}_\Lambda$, where $\mathbf{L} = \text{diag}(nL_1 - 1, \dots, nL_n - 1)$ is an $n \times n$ diagonal matrix. The vector \mathbf{z} is an integer vector of length n that is chosen such that the new lattice point components lie in an n -dimensional hypercube around the origin [28]. To find the vector \mathbf{z} , we first solve the

system of linear equations obtained from (7) and then choose an integer \mathbf{z} such that $|\lambda'_i| \leq nL_i - 1$, for $i = 1, \dots, n$. Therefore, we have

$$\lambda'_i = \begin{cases} x_i - z_i(nL_i - 1) & i = 1, \dots, k, \\ 2(x_i - z_i(nL_i - 1)) + \sum_{j=1}^k x'_j a_{j,i-k}, & i = k + 1, \dots, n, \end{cases}$$

where a_{ji} is the (j, i) -th entry of the matrix \mathbf{A} in \mathbf{G}_Λ . We consider $z_i = 0$, for $1 \leq i \leq k$ that leads to $x'_i = x_i$ and $|\lambda'_i| = |x_i| \leq nL_i - 1$. Moreover, for $k + 1 \leq i \leq n$, we have $-nL_i + 1 \leq 2(x_i - z_i(nL_i - 1)) + \sum_{j=1}^k x_j a_{j,i-k} \leq nL_i - 1$, or $-\frac{1}{2} + \frac{x_i}{nL_i - 1} + \frac{\sum_{j=1}^k x_j a_{j,i-k}}{2(nL_i - 1)} \leq z_i \leq \frac{1}{2} + \frac{x_i}{nL_i - 1} + \frac{\sum_{j=1}^k x_j a_{j,i-k}}{2(nL_i - 1)}$.

The above interval contains only one integer number, thus it has the unique solution $z_i = \left\lfloor \frac{1}{nL_i - 1} \left(x_i + \frac{1}{2} \sum_{j=1}^k a_{j,i-k} x_j \right) \right\rfloor$.

Indeed, we convert the vector \mathbf{x} to $\mathbf{x}' = \mathbf{x} - \mathbf{z}\mathbf{L}$, in order to embed the vector $\boldsymbol{\lambda}' = \mathbf{x}'\mathbf{G}_\Lambda$ to the following hypercube

$$\mathcal{L} = \left\{ x \in \mathbb{Z}^n \left| \begin{array}{ll} -\frac{n}{2}L_i \leq x_i \leq \frac{n}{2}L_i & i = 1, \dots, k, \\ -nL_i + 1 \leq x_i \leq nL_i - 1 & i = k + 1, \dots, n \end{array} \right. \right\}. \quad (8)$$

Replacing \mathbf{x} by the converted vector \mathbf{x}' , in the relation (5), the transmitted vector over the noisy AWGN channel is expressed as $\mathbf{y} = (2\mathbf{x}'\mathbf{G}_\Lambda - \mathbf{1} + 2\mathbf{e})\mathbf{P}$.

The encryption algorithm is shown in Fig. 3. The information rate of a lattice code Γ of length n (in bits/symbol) is defined to be $R = \log_2(|\Gamma|)/n$ [11]. Since the points of the lattice code $\Gamma = (2\Lambda \cap \mathcal{L}) - \mathbf{1}$ are in bijective correspondence with the information integer vectors \mathbf{m} , according to Eq.(6), the information rate of this lattice code is $R = \sum_{i=1}^n \log_2(2L_i)/n$.

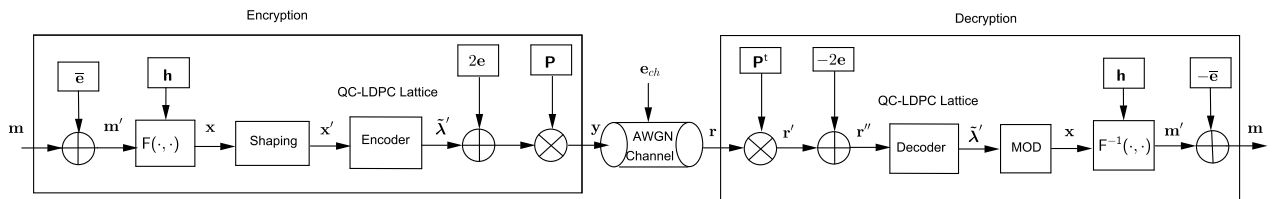

Fig. 3. The proposed joint encryption, encoding and modulation scheme based on QC-LDPC lattice codes

B. The Proposed Decryption Algorithm

The authorized receiver (Bob) attempts to decrypt the possibly erroneous received vector $\mathbf{r} = (2\mathbf{x}'\mathbf{G}_\Lambda - \mathbf{1} + 2\mathbf{e})\mathbf{P} + \mathbf{e}_{ch}$, where \mathbf{e}_{ch} is the AWGN channel noise that is drawn from an i.i.d. Gaussian distribution with variance σ^2 .

Using the secret keys $\{\mathbf{s}, \mathbf{h}, \mathbf{H}_{qc}, \mathbf{t}\}$, the ciphertext is decrypted as follows:

- 1) The received vector \mathbf{r} is multiplied by $\mathbf{P}^{-1} = \mathbf{P}^T$ to get

$$\mathbf{r}' = \mathbf{r}\mathbf{P}^T = (2\mathbf{x}'\mathbf{G}_\Lambda - \mathbf{1} + 2\mathbf{e}) + \mathbf{e}_{ch}\mathbf{P}^T.$$

- 2) Having the secret vector \mathbf{s} , the corresponding error vector \mathbf{e} and $\mathbf{r}'' = \mathbf{r}' - 2\mathbf{e}$ are computed.
- 3) The vector $\mathbf{r}'' = 2\mathbf{x}'\mathbf{G}_\Lambda - \mathbf{1} + \mathbf{e}_{ch}\mathbf{P}^T$ is decoded using \mathbf{H}_{qc} by applying the SPA iterative decoding algorithm of QC-LDPC lattices [27]. Then $\tilde{\mathbf{X}}' = 2\mathbf{x}'\mathbf{G}_\Lambda - \mathbf{1}$ is obtained.
- 4) The vector \mathbf{x} is recovered from the shaped lattice point $\tilde{\mathbf{X}}'$ using Algorithm 1.

Algorithm 1 Recover original vector

```

1: procedure MOD( $\tilde{\mathbf{X}}', (L_1, \dots, L_n), \mathbf{G}_\Lambda^{-1}$ )
2:    $\mathbf{x}' \leftarrow \left\lfloor \left( \frac{\tilde{\mathbf{X}}'+\mathbf{1}}{2} \right) \mathbf{G}_\Lambda^{-1} \right\rfloor$ 
3:   for  $i = 1 : n$  do
4:     if  $\text{mod}(x'_i, (nL_i - 1)) < \frac{n}{2}L_i$  then
5:        $r_i \leftarrow \text{mod}(x'_i, (nL_i - 1))$ 
6:     else
7:        $r_i \leftarrow \text{mod}(x'_i, (nL_i - 1)) - (nL_i - 1)$ 
8:     end if
9:   end for
10:  return  $\mathbf{x} = (r_1, \dots, r_n)$ .
11: end procedure

```

- 5) Retrieving the vector $\mathbf{m}' = \mathbf{m} + \bar{\mathbf{e}}$ from the vector $\mathbf{x} = \mathbf{m}'\mathbf{U}^\alpha$ is equivalent to computing $\mathbf{m}' = \mathbf{x}(\mathbf{U}^\alpha)^{-1}$ by the secret vector \mathbf{h} , in which $\alpha = \sum_{i=0}^{d-1} h_i 2^i$. Then, subtracting the vector $\bar{\mathbf{e}}$ from \mathbf{m}' recovers the original message \mathbf{m} .

V. EFFICIENCY

The efficiency of the cryptosystem is measured in terms of the key size and the computational complexity of encryption and decryption processes.

A. Complexity

Encryption is performed by computing $\mathbf{m}' = \mathbf{m} + \bar{\mathbf{e}}$, then mapping it to the vector $\mathbf{x} = \mathbf{m}'\mathbf{U}^\alpha$ by the function F through a multiplexer controlled by the binary vector \mathbf{h} . The vector \mathbf{x} is converted to the vector \mathbf{x}' using a hypercube shaping method and then encoded by a QC-LDPC lattice to a lattice point $\tilde{\mathbf{X}}' = 2\mathbf{x}'\mathbf{G}_\Lambda - \mathbf{1}$. By adding the intentional error vector $2\mathbf{e}$ and multiplying the

whole combination by the permutation matrix \mathbf{P} , the overall system becomes non-systematic. Therefore, an estimation of the computational complexity, caused by the encryption algorithm is given as

$$C_{encrypt} = C_{add}(\bar{\mathbf{e}}) + C_{compute}(F(\mathbf{m}', \mathbf{h})) + C_{shaping}(\mathbf{x}\mathbf{G}_\Lambda) + C_{encode}(\mathbf{x}') + C_{add}(2\mathbf{e}) + C_{product}(\mathbf{P}).$$

In the encryption process, the terms $C_{add}(\bar{\mathbf{e}})$, $C_{add}(2\mathbf{e})$ and $C_{product}(\mathbf{P})$ have lower order complexity, which are linear, than other terms. Indeed, the complexity of the encryption process is upper-bounded by the complexity of $C_{compute}(F((\mathbf{m} + \bar{\mathbf{e}}), \mathbf{h})) + C_{shaping}(\mathbf{x}\mathbf{G}_\Lambda) + C_{encode}(\mathbf{x}')$.

The time and space complexities of QC-LDPC lattice encoding are linear in terms of the dimension of lattice [27]. The overall computational complexity of the hypercube shaping for a $\lambda = \mathbf{x}\mathbf{G}_\Lambda \in \Lambda$ is $O(nw_c)$, where w_c is the average number of nonzero elements in a row of \mathbf{G}_Λ [26]. Since $F(\mathbf{m}', \mathbf{h}) = \mathbf{m}'\mathbf{U}^\alpha$, where $\alpha = \sum_{i=0}^{d-1} h_i 2^i$, then $C_{compute}(F(\mathbf{m}', \mathbf{h}))$ is equal to the computational complexity of vector $\mathbf{m}' = (\mathbf{m} + \bar{\mathbf{e}})$ times matrix \mathbf{U}^α . The function can be implemented using a similar pipelined architecture proposed in [38]. Let $\alpha = h_0 + 2h_1 + 2^2h_2 + \dots + 2^{d-1}h_{d-1}$, then $\mathbf{U}^\alpha = \mathbf{U}^{h_0} \cdot (\mathbf{U}^2)^{h_1} \cdot (\mathbf{U}^{2^2})^{h_2} \dots (\mathbf{U}^{2^{d-1}})^{h_{d-1}}$, where h_i s are 0 or 1. Indeed, the proposed function can be implemented using the matrices $\mathbf{U}, \mathbf{U}^2, \dots, \mathbf{U}^{2^{d-1}}$ and d number of 2-to-1 multiplexers instead of all matrices (2^d numbers) in S and one 2^d -to-1 multiplexer. Therefore, its computational complexity is of order $O(n^2)$. As a consequence, the complexity of the encryption process is of order $O(n^2)$, in terms of lattice dimension n . Since, we have d stages in the pipeline, the latency of the architecture is $O(d)$.

Using similar arguments, the decryption complexity is expressed as

$$C_{decrypt} = C_{product}(\mathbf{P}^T) + C_{add}(-2\mathbf{e}) + C_{decode}(\mathbf{r}'') + C_{MOD}(\tilde{\mathbf{X}}') + C_{compute}(F^{-1}(\mathbf{x})) + C_{add}(-\bar{\mathbf{e}}).$$

Since the dominant terms that have much larger effect on the implementation complexity are $C_{decode}(\mathbf{r}'')$, $C_{MOD}(\tilde{\mathbf{X}}')$ and $C_{compute}(F^{-1}(\mathbf{x}))$, the decryption complexity is upper-bounded by the complexity of $C_{decode}(\mathbf{r}'') + C_{MOD}(\tilde{\mathbf{X}}') + C_{compute}(F^{-1}(\mathbf{x}))$.

The QC-LDPC lattice decoding has computational complexity of $O(nd_v I)$, where I is the maximum number of iterations required by the decoding algorithm to correct the error and d_v is the column weight of the parity-check matrix \mathbf{H}_{qc} . Hence, QC-LDPC lattices have linear computational complexity in the lattice dimension [27].

The information integer components x_i are recovered from x'_i after multiplication by the matrix \mathbf{G}_Λ^{-1} followed by a simple modulo operation that is explained in Algorithm 1. Therefore, $C_{MOD}(\tilde{\mathbf{X}}') = C_{mult}(\mathbf{G}_\Lambda^{-1})$, where according to the structure of \mathbf{G}_Λ^{-1} , it can be demonstrated that

it is equal to complexity of the encoding algorithm of QC-LDPC lattices which is linear in terms of lattice dimension. The computational complexity of applying $F^{-1}(\mathbf{x})$ is equivalent to multiplication of the matrix $(\mathbf{U}^\alpha)^{-1}$ to the vector \mathbf{x} . In the same way, its computational complexity is of order $O(n^2)$. Hence, the total computational complexity for decryption is bounded by $O(n^2)$.

The complexity of computing the nonlinear function F and F^{-1} is a bottleneck for our scheme. Indeed, we had to sacrifice the linear complexity of our design to prevent some chosen plaintext attacks like differential attack against the proposed scheme. However, designing another nonlinear function which can be implemented with linear complexity is desirable and open for further research.

B. Message expansion

According to Section IV-A, the shaped vectors $2\mathbf{x}'\mathbf{G}_\Lambda - \mathbf{1} \in 2\Lambda - \mathbf{1}$ are uniformly distributed over the hypercube $2\mathcal{L} - \mathbf{1}$, where \mathcal{L} is presented in Eq. (8). Therefore, the ciphertext $\mathbf{y} = (2\mathbf{x}'\mathbf{G}_\Lambda - \mathbf{1} + 2\mathbf{e})\mathbf{P}$ belongs to the following set

$$\left\{ x \in \mathbb{Z}^n \left| \begin{array}{ll} -nL_i - 1 \leq x_i \leq nL_i + 1 & i = 1, \dots, k, \\ -2nL_i + 1 \leq x_i \leq 2nL_i - 1 & i = k + 1, \dots, n \end{array} \right. \right\}. \quad (9)$$

For simplicity, we consider $L_i = L$, for $i = 1, \dots, n$. Then, the information rate of our cryptosystem is $R = \log_2(2L)$. Furthermore, according to Eq. (6), the integer vector \mathbf{m} is restricted to the finite constellation $m_i \in \{-L, \dots, L - 1\}$, for $i = 1, \dots, n$. Therefore, the plaintext size is at most $n\lceil \log_2(2L) \rceil$ bits and the number of bits required to derive a ciphertext is $(n - k)\lceil \log_2(4nL - 1) \rceil + k\lceil \log_2(2nL + 3) \rceil$. Therefore, the message expansion of our cryptosystem is

$$\frac{(n - k)\lceil \log_2(4nL - 1) \rceil + k\lceil \log_2(2nL + 3) \rceil}{n\lceil \log_2(2L) \rceil}.$$

If we consider the parameters $n_0 = 6$, $d_v = 3$ and $b = 43$ that introduce a QC-LDPC lattice with $(k, n) = (215, 258)$, this ratio approaches 1 as L approaches infinity. Moreover, the message expansion of our cryptosystem, belongs to the interval $[1, 5.6]$, for $L \geq 2$ and the proposed parameters.

C. Key size

The secret key that needs to be exchanged between the sender and authorized receiver consists of an initial value \mathbf{s} of the l_1 -bit LFSR for generating the error vector \mathbf{e} , the parity-check matrix \mathbf{H}_{qc} for decoding of QC-LDPC lattices, the d -bit vector \mathbf{h} that determines the selection logic of

the multiplexer for nonlinear mapping F , and the vector \mathbf{t} correspond to the permutation matrix \mathbf{P} .

In the proposed encryption scheme, the random error vector \mathbf{e} is generated using an l_1 -bit LFSR along with a modular division circuit proposed in [37]. Therefore, we store the initial vector \mathbf{s} of the LFSR that requires a memory of approximately $l_1 = \lceil \log_2 n \rceil$ bits.

The required memory for saving the vector \mathbf{h} is l_2 bits. We consider it in order for the cryptosystem to be secure against different cryptanalysis. Here we consider it of size approximately $7\lceil \log_2 n \rceil$.

To save the secret key \mathbf{H}_{qc} , we can just save the nonzero positions of the first rows of $(\mathbf{H}_i)_{b \times b}$, for $i = 0, \dots, n_0 - 1$, and keep it as the secret parity-check matrix. Thus, its storage involves at most $l_3 = d_v \lceil \log_2 b \rceil n_0$ memory bits, where d_v is the row/column Hamming weight of \mathbf{H}_i , for $i = 0, \dots, n_0 - 1$.

We use an efficient hardware structure for the permutation of a vector that is based on a shift register and some multiplexers [17]. By this method, for different message blocks, we generate different permutation matrices. Under this low hardware complexity, we can reduce the key size of the scheme compared to other joint schemes as well as be secure against known attacks. The designed hardware structure for permuting a vector by \mathbf{P} , is shown in Fig. 4 that

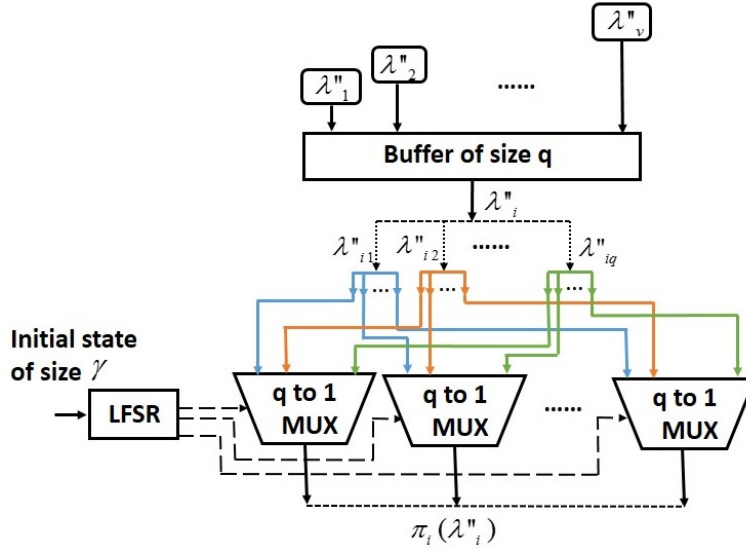

Fig. 4. Hardware design for vector permutation by the matrix \mathbf{P} .

serves a buffer, an LFSR and some q -to-1 multiplexers. In this structure, an LFSR of size $\gamma = \lceil \log_2 q \rceil$ generates data control line of the q -to-1 multiplexers. For permuting the n -tuple

vector $\boldsymbol{\lambda}'' = 2\mathbf{x}'\mathbf{G}_\Lambda - \mathbf{1} + 2\mathbf{e}$ in the last step of the encryption process, we divide it into q -tuple vectors $\boldsymbol{\lambda}_i''$, for $i = 1, \dots, v$. Then, the first q -tuple vector $\boldsymbol{\lambda}_1''$ is stored in the buffer and is given as the input of the q -to-1 multiplexers. Each component of $\boldsymbol{\lambda}_i''$ belongs to the hypercube defined in Eq. (9). Therefore, each component can be considered with maximum $r = \lceil \log_2(4nL - 1) \rceil$ bits. Then, we need r multiplexers with q inputs in order to the r bits of each component of $\boldsymbol{\lambda}_i''$ be permuted simultaneously and result in the same component after permutation. In this way, according to the control line generated by the LFSR, the multiplexers select one of the bits from the input vector $\boldsymbol{\lambda}_{1_j}''$, for $j = 1, \dots, q$, as the output. By the next output of the LFSR, the multiplexer selects another component of the input vector. Finally, the q -tuple vector $\boldsymbol{\lambda}_1''$ is permuted at the end of the first period of the LFSR which is $2^\gamma - 1 = q$, where γ is the size of the initial vector. Then, the second q -tuple vector $\boldsymbol{\lambda}_2''$ is stored in the buffer and the initial value of the LFSR is changed. In the same way, $\boldsymbol{\lambda}_2''$ is permuted after reaching the period of the LFSR. Therefore, each of $\boldsymbol{\lambda}_i''$, for $i = 1, \dots, v$, is permuted at the end of a period of the LFSR. Indeed, each permutation matrix $\boldsymbol{\pi}_i$, for $i = 1, \dots, v$, is controlled by the corresponding initial vector of the LFSR to determine the selection logic of the multiplexers. Since the $q \times q$ permutation sub-matrices $\boldsymbol{\pi}_i$, for $i = 1, \dots, v$, are saved instead of the permutation matrix \mathbf{P} , it is needed to save only the corresponding initial vector of the LFSR. Thus, the required memory bits for storing the permutation matrix \mathbf{P} is $l_4 = v \lceil \log_2 q \rceil$ bits.

Hence, the actual key length of the proposed cryptosystem is equal to $l_1 + l_2 + l_3 + l_4 = \lceil \log_2 n \rceil + 7 \lceil \log_2 n \rceil + d_v \lceil \log_2 b \rceil n_0 + v \lceil \log_2 q \rceil$ bits.

For the proposed QC-LDPC lattice with $(k, n) = (215, 258)$ and parameters $n_0 = 6$, $d_v = 3$ and $b = 43$, we can choose $q = 43$ for the permutation matrix \mathbf{P} and $l_2 = 61$ for the vector \mathbf{h} . Therefore, the key size of the proposed scheme is equal to 214 bits. This key size is small comparing with those of the proposed code and lattice based cryptography.

We summarize the operation characteristics of the proposed scheme in terms of its parameters in TABLE I.

VI. SECURITY OF THE PROPOSED SCHEME

In general, security of the RN-like cryptosystems is considered against four potential attacks reported in the literature including brute force attack, differential-style attack [16], Rao-Nam attack [2], Struik-Tilburg attack [4] and message-resend attack [13].

TABLE I
OPERATION CHARACTERISTICS OF THE PROPOSED SCHEME.

Plaintext size (bit)	$n\lceil\log_2(2L)\rceil$
Ciphertext size (bit)	$(n - k)\lceil\log_2(4nL - 1)\rceil + k\lceil\log_2(2nL + 3)\rceil$
Key size (bit)	$8\lceil\log_2 n\rceil + d_v\lceil\log_2 b\rceil n_0 + v\lceil\log_2 q\rceil$
Information rate	$R = \log_2(2L)$
Decryption Ops.	$O(n^2)$
Encryption Ops.	$O(n^2)$

The last three attacks are performed based on the linearity of the encoding step in the encryption process. They are not applicable here because the use of the nonlinear function F in the encryption algorithm prevents such attacks from being successful.

Rao-Nam attack is applied on any RN-like cryptosystems to estimate the encryption matrix from a large set of plaintext-ciphertext pairs [2]. The security of the RN-like schemes against this kind of attacks depends mostly on the Hamming weight of the intentional error vectors. This attack succeeds only if the ratio of the Hamming weight of the intentional error vector over n is small and it does not if its average Hamming weight is approximately $n/2$ [2]. According to the applied method for producing the intentional error \mathbf{e} in our scheme, it has the Hamming weight $n/2$ on average. In this method, the length of \mathbf{e} is equal to the period of the LFSR. Indeed, the output string (one cycle) of the LFSR is considered as the intentional error \mathbf{e} . On the other hand, applying the nonlinear function F on the plaintext before its encoding, does not allow to estimate the encryption matrix from a large set of plaintext-ciphertext pairs. Therefore, Rao-Nam attack can not be applied on the proposed scheme.

Struik-Tilburg attack requires enciphering an arbitrary message \mathbf{m} until all distinct ciphertexts are obtained [4]. This attack is based on deriving the rows of the encryption matrix \mathbf{G}_Λ by constructing unit vectors from the chosen plaintext or by solving a set of linear equations. The proposed scheme is not vulnerable to Struik-Tilburg attack and message-resent attack [13], because the plaintext is transformed by means of an invertible and nonlinear function F before its encoding.

It is known that the security of nonlinear cryptosystems is determined by the intentionally random error vectors and the nonlinear function F [16]. Indeed, the encoding step and the permutation step increase further the security of the nonlinear system. The main attack against nonlinear cryptosystems is a differential-style attack that is a chosen plaintext attack [16]. In the

sequel, the security of the proposed cryptosystem is analyzed against Brute-Force and Differential attacks.

A. Brute-Force Attacks

The purpose of this attack is the enumeration of all possible secret keys $\{\mathbf{s}, \mathbf{h}, \mathbf{H}_{qc}, \mathbf{t}\}$ in the proposed scheme until a meaningful message is obtained.

- 1) The matrix \mathbf{H}_{qc} is the parity-check matrix (free of length-4 cycles) of an RDF-QC-LDPC code with code rate $R = (n_0 - 1)/n_0$, code length $n = bn_0$ and column weight d_v . An attacker looks for the parity-check matrix corresponding to the used RDF-QC-LDPC code having public parameters b, d_v, n_0 . For large enough parameters b and n_0 , it has been demonstrated that there are a large number of different RDF-QC-LDPC codes with the same code length, dimension and row/column weight of the parity-check matrices [33]. The number of different QC-LDPC codes free of length-4 cycles with the parameters b, d_v, n_0 that can be designed through the RDF-based approach, is lower bounded by [33, Theorem 4.12]

$$N_{RDF}(b, d_v, n_0) \geq \frac{1}{b} \binom{b}{d_v}^{n_0} \prod_{l=0}^{n_0-1} \prod_{j=1}^{d_v-1} \frac{b}{b-j} - \frac{j [2 - b \bmod 2 + (j^2 - 1)/2 + l \cdot d_v \cdot (d_v - 1)]}{b-j}.$$

For the proposed parameter $b = 43, d_v = 3$ and $n_0 = 6$, there are 2^{61} different RDF-QC-LDPC codes with $n = 258$ and code rate $R = 5/6$.

- 2) We use an LFSR with $l_1 = \lceil \log_2 n \rceil$ -bit initial vector and a modular division circuit to generate the vector \mathbf{e} . With a suitable choice of the feedback polynomial used in the circuit, the total choice of random vector \mathbf{e} is $(2^{l_1} - 1)^2 \approx (2^{\lceil \log_2 n \rceil})^2$. For our example, this number is approximately equal to 2^{18} .
- 3) The l_2 -bit vector \mathbf{h} determines the image of the nonlinear mapping F . The total number of the different vectors \mathbf{h} is 2^{l_2} that is 2^{61} , for our cryptosystem.
- 4) Each permutation matrix π_i , for $i = 1, \dots, v$, of the block diagonal permutation matrices \mathbf{P} is controlled by different initial vectors of the LFSR of size $\lceil \log_2 q \rceil$. The number of different initial vectors for this LFSR is $2^{\lceil \log_2 q \rceil}$. Therefore, there are $2^{\lceil \log_2 q \rceil}$ different candidates for each π_i , for $i = 1, \dots, v$. Hence, the total number of different permutation matrices \mathbf{P} is equal to $(2^{\lceil \log_2 q \rceil})^v$, that is approximately 2^{36} for $q = 43$ and $v = 6$.

Consequently, the complexity of the brute force attack is approximately 2^{176} which indicates a high order of security.

B. Differential Cryptanalysis

The j th instance of the ciphertext in our cryptosystem is considered as

$$\mathbf{y}_j = \left(2F((\mathbf{m}_j + \bar{\mathbf{e}}_{(j)N_e}), \mathbf{h}_{(j)N_h}) \mathbf{G}_\Lambda - \mathbf{1} + 2\mathbf{e}_{(j)N_e} \right) \mathbf{P}_{(j)N_p},$$

which varies with the number of clock cycles. The first round of the encryption is only used in the chosen plaintext attack proposed in [16]. Indeed, the ciphertexts are computed for each message after resetting the encryption machine. Since, an attacker call \mathbf{y}_1 for different chosen plaintexts, the subscripts of \mathbf{m}_i and \mathbf{y}_i are ignored for the time being and $\mathbf{m}^{(i)}$ and $\mathbf{y}^{(i)}$ represent the plaintext and the corresponding ciphertext used in the i th call of \mathbf{y}_1 . In our scheme, $\mathbf{y}^{(\beta)}$, for $\beta = 0, \dots, 2^l$, is considered as the β th instance of the ciphertext corresponding to the plaintext $\mathbf{m}^{(\beta)}$ as follows

$$\mathbf{y}^{(\beta)} = \left(2 \left(F((\mathbf{m}^{(\beta)} + \bar{\mathbf{e}}_1), \mathbf{h}_1) \right)' \mathbf{G}_\Lambda - \mathbf{1} + 2\mathbf{e}_1 \right) \mathbf{P}_1.$$

This attack has three steps: estimate the permuted generator matrix $\mathbf{G}_\Lambda \mathbf{P}_1$, recover the intentional vector \mathbf{e}_1 , and decode the ciphertext. In the first step, the attacker computes the ciphertext corresponding to the first round of the encryption for the binary plaintext $\mathbf{m}^{(\beta)}$, for $\beta = 0, \dots, 2^l$, in which the last $(n - k)$ bit of message is equal to zero. Since,

$$\begin{aligned} \mathbf{y}^{(\beta)} &= \left(2\mathbf{x}'^{(\beta)} \mathbf{G}_\Lambda - \mathbf{1} + 2\mathbf{e}_1 \right) \mathbf{P}_1 \\ &= \left(2(\mathbf{x}^{(\beta)} - \mathbf{z}\mathbf{L}) \mathbf{G}_\Lambda - \mathbf{1} + 2\mathbf{e}_1 \right) \mathbf{P}_1, \end{aligned}$$

the attacker computes

$$\begin{aligned} \mathbf{y}^{(\beta)} \pmod{\mathbf{L}} &= \left(2\mathbf{x}^{(\beta)} \mathbf{G}_\Lambda - \mathbf{1} + 2\mathbf{e}_1 \right) \mathbf{P}_1 \\ &= \left(2F((\mathbf{m}^{(\beta)} + \bar{\mathbf{e}}_1), \mathbf{h}_1) \mathbf{G}_\Lambda - \mathbf{1} + 2\mathbf{e}_1 \right) \mathbf{P}_1. \end{aligned}$$

Then, for $\beta = 0, \dots, 2^l$, the attacker has

$$\mathbf{v}^{(\beta)} = \frac{\mathbf{y}^{(\beta)} \pmod{\mathbf{L}} + \mathbf{1}}{2} = F((\mathbf{m}^{(\beta)} + \bar{\mathbf{e}}_1), \mathbf{h}_1) \mathbf{G}_\Lambda \mathbf{P}_1 + \mathbf{e}_1 \mathbf{P}_1.$$

Indeed, the attacker computes

$$\mathbf{v}^{(i)} = F((\mathbf{m}^{(i)} + \bar{\mathbf{e}}_1), \mathbf{h}_1) \mathbf{G}_\Lambda \mathbf{P}_1 + \mathbf{e}_1 \mathbf{P}_1,$$

for $i = 1, \dots, 2^l$, to obtain

$$\begin{aligned} \sum_{\beta=1}^{2^l} \mathbf{v}^{(\beta)} &= \sum_{\beta=1}^{2^l} F((\mathbf{m}^{(\beta)} + \bar{\mathbf{e}}_1), \mathbf{h}_1) \mathbf{G}_\Lambda \mathbf{P}_1 + \mathbf{e}_1 \mathbf{P}_1 \\ &= \sum_{\beta=1}^{2^l} F((\mathbf{m}^{(\beta)} + \bar{\mathbf{e}}_1), \mathbf{h}_1) \mathbf{G}_\Lambda \mathbf{P}_1 + \sum_{\beta=1}^{2^l} \mathbf{e}_1 \mathbf{P}_1. \end{aligned}$$

On the other hand, according to Eq. (1), we have

$$F((\mathbf{m}^{(\beta)} + \bar{\mathbf{e}}_1), \mathbf{h}_1) \mathbf{G}_\Lambda \mathbf{P}_1 = F((\mathbf{m}^{(\beta)} + \bar{\mathbf{e}}_1), \mathbf{h}_1)_{[1:k]} \mathbf{G}_C \mathbf{P}_1 + F((\mathbf{m}^{(\beta)} + \bar{\mathbf{e}}_1), \mathbf{h}_1)_{[k+1:n]} \begin{bmatrix} \mathbf{0} & 2\mathbf{I}_{n-k} \end{bmatrix} \mathbf{P}_1,$$

where \mathbf{G}_C is the systematic form of the generator matrix of the used QC-LDPC code (Eq. (4)) and $\mathbf{x}_{[1:k]}$ denotes the entries 1 to k of the vector \mathbf{x} . Therefore, recovering \mathbf{G}_C is sufficient for determining the \mathbf{G}_Λ and the attacker has the following steps to recover $\mathbf{G}_\Lambda \mathbf{P}_1$

$$\sum_{\beta=1}^{2^l} \mathbf{v}^{(\beta)} \equiv \left(\sum_{\beta=1}^{2^l} F'((\mathbf{m}^{(\beta)} + \bar{\mathbf{e}}_1), \mathbf{h}_1) \right) \mathbf{G}_C \mathbf{P}_1 \pmod{2},$$

where $F'(\mathbf{a}, \mathbf{b}) = \{f_1(\mathbf{a}, \mathbf{b}) \pmod{2}, \dots, f_k(\mathbf{a}, \mathbf{b}) \pmod{2}\}$ and $f_i(\mathbf{a}, \mathbf{b}) \pmod{2}$'s are the Boolean functions defined in Eq. (3). The algebraic degree of each component function and their nonzero linear combination is $d+1$ [38]. Therefore, the algebraic degree of function F' is equal to $d+1$.

Let $L[u_1, \dots, u_l]$ be the list of all 2^l possible linear combinations of u_1, \dots, u_l where $u_i \in \mathbb{F}_2^n$ is a vector with a 1 in the i th position and zeros in all the other positions. We recall that the l th derivative of a Boolean function $f(\mathbf{x})$ is defined as $\Delta_{u_1, \dots, u_l}^{(l)} f(\mathbf{x}) = \sum_{\mathbf{c} \in L[u_1, \dots, u_l]} f(\mathbf{x} + \mathbf{c})$ [39]. Therefore, since $\mathbf{m}^{(\beta)}$'s are binary vectors with zero components in the last $(n-k)$ positions,

$$\begin{aligned} \sum_{\beta=1}^{2^l} \mathbf{v}^{(\beta)} \pmod{2} &= \left(\sum_{\mathbf{m}^{(\beta)} \in L[u_1, \dots, u_l]} F'((\mathbf{m}^{(\beta)} + \bar{\mathbf{e}}_1), \mathbf{h}_1) \right) \mathbf{G}_C \mathbf{P}_1 \\ &= \left(\Delta_{u_1, \dots, u_l}^{(l)} F'(\bar{\mathbf{e}}_1, \mathbf{h}_1) \right) \mathbf{G}_C \mathbf{P}_1. \end{aligned} \quad (10)$$

When $l = \deg(F')$ and u_1, \dots, u_l are chosen in which, for $\rho = 1, \dots, l$, $i_\rho \leq k$, then $\Delta_{u_1, \dots, u_l}^{(l)} F'(\bar{\mathbf{e}}_1, \mathbf{h}_1)$ is a constant vector independent of $\bar{\mathbf{e}}_1$. Hence, Eq. (10) returns a linear equation with respect to $\mathbf{G}_C \mathbf{P}_1$. If the attacker has k such linear independent equations, then he can find $\mathbf{G}_C \mathbf{P}_1$. Therefore, the attacker computes Eq. (10) for other messages, at least k times, to prepare a system of k linear equations with respect to $\mathbf{G}_C \mathbf{P}_1$ and then solve it. The complexity of the first step of the attack is $O(k \times 2^{\deg(F')})$. Since the vector \mathbf{h} is secret, the attacker needs 2^{d-1} guesses. Hence, the overall complexity of recovering $\mathbf{G}_C \mathbf{P}_1$ is of order $O(k \times 2^{d-1} \times 2^{\deg(F')}) = O(k \times 2^{d-1} \times 2^{d+1}) = O(k \times 2^{2d})$. For the proposed QC-LDPC lattice with $(k, n) = (215, 258)$ and $d = 61$, the complexity of the attack is 2^{129} .

The next steps of this attack involve recovering \mathbf{e}_1 and decrypting the ciphertext using \mathbf{P}_1 . The first instance of the ciphertext is given as

$$\mathbf{v}^{(1)} = F((\mathbf{m}^{(1)} + \bar{\mathbf{e}}_1), \mathbf{h}_1) \mathbf{G}_\Lambda \mathbf{P}_1 + \mathbf{e}_1 \mathbf{P}_1. \quad (11)$$

The attacker applies it to $\mathbf{m}^{(1)} = (0, \dots, 0)$, obtaining

$$\mathbf{v}^{(1)} \equiv F'(\bar{\mathbf{e}}_1, \mathbf{h}_1) \mathbf{G}_C \mathbf{P}_1 + \mathbf{e}_1 \mathbf{P}_1 \pmod{2}. \quad (12)$$

Since $\mathbf{G}_C \mathbf{P}_1$ has been estimated in the previous step, the attacker should estimate $F'(\bar{\mathbf{e}}_1, \mathbf{h}_1)$ and $F'(\bar{\mathbf{e}}_1, \mathbf{h}_1) \mathbf{G}_C \mathbf{P}_1$ for all possible vectors \mathbf{e}_1 and \mathbf{h}_1 . The corresponding $\mathbf{e}_1 \mathbf{P}_1$ can be computed using Eq. (12), that is, $\mathbf{v}^{(1)} \pmod{2} \oplus F'(\bar{\mathbf{e}}_1, \mathbf{h}_1) \mathbf{G}_C \mathbf{P}_1 = \mathbf{e}_1 \mathbf{P}_1$. Recovering the matrix \mathbf{P}_1 , based on this equation, requires vq^2 search for the different choices for $(\mathbf{e}_1, \mathbf{h}_1)$. Indeed, Eq. (12) constructs a linear system of equations $\mathbf{x} = \mathbf{e}_1 \mathbf{P}_1$ in terms of the \mathbf{P}_1 entries as its variables. With \mathbf{P}_1 as a block diagonal matrix, we have $\mathbf{x} = (\mathbf{e}_{1[1:q]} \pi_1, \mathbf{e}_{1[q+1:2q]} \pi_2, \dots, \mathbf{e}_{1[(v-1)q+1:vq]} \pi_v)$, where $\mathbf{e}_{1[(i-1)q+1:iq]}$ is the i th q bits of \mathbf{e}_1 . Moreover, each sub-permutation matrix has one nonzero component in each column, leading to the equation $\mathbf{x}_j = \mathbf{e}_{1[(j-1)q+1:jq]} \pi_j$ has q^2 solutions. Therefore, there are vq^2 solutions for \mathbf{P}_1 in this system. The complexity of finding $\{\tilde{\mathbf{e}}_1, \tilde{\mathbf{h}}_1, \tilde{\mathbf{P}}_1\}$ that satisfy Eq. (12) is $O(2^{(l_1+l_2)} \times vq^2)$. The attacker repeats the same work to find $\{\bar{\mathbf{e}}_1, \bar{\mathbf{h}}_1, \bar{\mathbf{P}}_1\}$ satisfying Eq. (11) using an arbitrary message with complexity $O(2^{(l_1+l_2)} \times vq^2)$. Then, the attacker compares $\{\tilde{\mathbf{e}}_1, \tilde{\mathbf{h}}_1, \tilde{\mathbf{P}}_1\}$ and $\{\bar{\mathbf{e}}_1, \bar{\mathbf{h}}_1, \bar{\mathbf{P}}_1\}$ in order to verify the suitable set for this step. Hence, the complexity of estimating $\{\mathbf{e}_1, \mathbf{h}_1, \mathbf{P}_1\}$ is approximately $O(2^{(l_1+l_2+1)} \times 2vq^2)$, which is almost $O(2^{84})$ for the proposed scheme. At this moment, the attacker can decrypt any $\mathbf{v}^{(1)}$ using $\{\mathbf{e}_1, \mathbf{h}_1, \mathbf{P}_1\}$ and $\mathbf{G}_C \mathbf{P}_1$. Hence, the overall complexity for decrypting $\mathbf{v}^{(1)}$ is $O(k \times 2^{2d} + 2^{(l_1+l_2+1+1)} \times 2vq^2) \approx O(2^{129})$. Since the intentional error vector and permutation matrix change with each message, the encryption matrix $\mathbf{G}_C \mathbf{P}_i$ and each vector $\mathbf{e}_i \mathbf{P}_i$ change in the i th round of encryption, while \mathbf{h}_i s are known after estimation of \mathbf{h}_1 . Therefore, for recovering all keys, the attacker can consider the zero vector as a message and compute the ciphertext $\mathbf{v}^{(2)} = F(\bar{\mathbf{e}}_2, \mathbf{h}_2) \mathbf{G}_A \mathbf{P}_2 + \mathbf{e}_2 \mathbf{P}_2$.

Next, $\mathbf{G}_C \mathbf{P}_2$ is estimated with complexity of order $O(k \times 2^{\deg(F')}) = O(k \times 2^{d+1})$, approximately $O(2^{70})$ in our case. Furthermore, \mathbf{P}_2 is computed based on the above equation of $\mathbf{v}^{(2)}$ in the similar way as mentioned above. The complexity of computing the other encryption matrix $\mathbf{G}_C \mathbf{P}_i$, for $i = 3, \dots$, in each round is $O(2^{70})$. Thus, the overall complexity of this attack is $O(2^{129} + N_p \times 2^{70})$, where N_p is the number of possible permutations. As a consequence, the overall complexity for the proposed parameters is $O(2^{129} + 2^{36} \times 2^{70}) \approx O(2^{129})$. Therefore, with the proposed parameters, we achieve a security level of 128-bit.

VII. COMPARISON

In this section, we compare our proposed lattice based cryptosystem with [12], [17] and [19], in which [12] is a lattice based joint scheme (based on LDLC lattices) and the others are based on error correcting codes. Moreover, in TABLE II, we review a number of previous schemes that join error correction and encryption in one process to enable efficient implementations.

Although, the existing schemes based on lattices and error correcting codes are not in the same category, we also point out the results of the joint schemes based on error correcting codes to provide an intuition about the counterpart of lattice based schemes.

The recent work of Stuart and Deepthi [17] is an RN-like scheme based on QC-LDPC codes that strengthen the cryptosystem against differential attacks. It has the smallest key size among other RN-like schemes and its complexity of encryption and decryption is of $O(n^2)$ due to the used nonlinear function in its design. Similar to other RN-like schemes, the output of this scheme is fed into a modulator to transmit through an AWGN channel.

TABLE II
COMPARISON OF THE PROPOSED SCHEME WITH OTHER SECURE CHANNEL CODING SCHEMES.

Cryptosystem	Underlying code, $C(n, k)$	Information rate	key size
Rao [1]	Goppa code, $C(1024, 524)$, coding rate= 0.51	N/A	2 Mbits
Rao and Nam [2]	Hamming code, $C(72, 64)$, coding rate= 0.89	N/A	18 kbits
Sobhi Afshar et al. [6]	EG-QC-LDPC code, $C(2044, 1024)$, coding rate= 0.5	N/A	2.5 kbits
Hooshmand et al. [7]	EDF-QC-LDPC code, $C(2470, 2223)$, coding rate= 0.9	N/A	3.55 kbits
Esmailiet et al. [9]	QC-LDPC code, $C(2048, 1536)$, coding rate= 0.75	N/A	2.191 kbits
Esmaili and Gulliver [10]	QC-LDPC code, $C(2048, 1536)$, coding rate= 0.75	N/A	2.22 kbits
Adamo et al. (ECBC) [15]	LDPC code, $C(256, 128)$, coding rate= 0.5	N/A	82 kbits.
Pisek et al. [19]	QC-LDPC code, $C(128, 256)$, coding rate= 0.5	N/A	128 bits
Stuart and Deepthi [17]	EDF-QC-LDPC code, $C(124, 248)$, coding rate= 0.5	N/A	182 bits
LDLC lattice based cryptosystem [12]	Latin square LDLC lattice, $n = 10^4$ symbols	N/A	3 Mbits
The proposed lattice based cryptosystem	RDF-QC-LDPC code, $C(258, 215)$, $L = 16$	5	214 bits

The most efficient joint AES-coding scheme is proposed in [19], where QC-LDPC codes are embedded in each round of the AES encryption and decryption. This scheme consists of two parts for encryption and channel coding, with the encryption part which is more powerful than classical AES. The coding part of the proposed scheme outperforms other conventional joint AES-coding schemes. It applies the same parity-check matrix for the encryption and encoding parts. Promising ideas such as using lower triangular matrices and the quasi-cyclic structure of the LDPC code and using the same hardware resource for both parts, reduce power consumption compared to other joint AES-coding schemes [19]. Encryption and channel coding cannot be applied simultaneously in [19] and the output of encryption is fed into the encoder and then the resulting data is passed through the QPSK modulator to transmit via an AWGN channel.

Unlike the proposed schemes in TABLE II, we have merged these three steps into a single step using efficient lattices in our cryptosystem. This provides less delay, lower implementation complexity and better error performance in overall for high SNR or bandlimited channels. The

column three in TABLE II describes the average information bits per symbol in the transmission which is not available for other schemes. If we want compute the average information bits per symbol in the transmission of a joint scheme, the coding rate of the used code in the structure of the scheme should multiply with the rate of a modulation that will be applied after. Since after encoding the rate of the joint schemes is less than 1, they should use high order modulation to compensate this low rate for bandlimited AWGN channels. For example, with the proposed parameters in TABLE II, the information rate of our scheme is 5. To reach the same information rate with the code based schemes like [17] and [19], which have coding rate 0.5, should use a high order modulation like 1024-QAM after coding step ($0.5 \times 10 = 5$). However, applying high order modulation makes the error performance weaker. Therefore, code based schemes are not appropriate for bandlimited channels without combining them with high order modulation. In contrast, the lattice codes are high order modulation schemes with error correction capability and provide high information rate. Since there are not such a complete setting about concatenation of AES-joint schemes or RN-like schemes and a high order modulation in the literature, we can not have a fair comparison about the overall error performance of joint schemes based on codes and our proposed scheme. Our lattice based scheme is the first candidate introducing a scheme for secure communication on bandlimited channels.

In the sequel, we compare the key size of our cryptosystem with the LDLC lattice based scheme. In [12], Latin square LDLCs are used to provide a joint encryption and encoding scheme. The encryption and decryption complexity of the proposed LDLC based scheme is $O(n^2\beta)$ and $O(n^2\delta)$, respectively, where β and δ are the maximum required memory to save each entry of its rational generator matrix and its secret key in binary form, respectively, and n is the lattice dimension [12]. On the other hand, the ciphertext \mathbf{c} is transmitted through an “unconstrained” power AWGN channel. Indeed, the shaping is removed to decrease the encryption complexity, while the computational complexity of the encryption/encoding grows rapidly due to the existence of unbounded lattice points and its average transmitted power becoming too large.

The Latin square LDLC lattices are introduced by the parity-check matrix \mathbf{H} which is an $n \times n$ Latin square. This matrix is determined by a generating sequence set $\mathcal{H} = \{h_1, h_2, \dots, h_d\}$, where h_i s are nonzero values at the appropriate locations of the used Latin square \mathbf{H} . The generating sequence set \mathcal{H} is considered as the secret key of the LDLC based scheme, instead of its corresponding parity-check matrix \mathbf{H} [12]. In this way, the legitimate receiver has to construct the same parity-check matrix \mathbf{H} using the secret key \mathcal{H} and is able to recover the original message

in decryption. It can be shown that the generating set \mathcal{H} does not result in a unique parity-check matrix for the Latin square LDLC that is used for decryption, and then the qualified receiver is not able to decrypt the ciphertexts correctly. As there are $\mathcal{L}(n) = n! \sum_{\mathbf{A} \in B_n} (-1)^{\sigma_0(\mathbf{A})} \binom{per(\mathbf{A})}{n}$, $n \times n$ Latin squares, where B_n is the set of all binary $n \times n$ matrices, $\sigma_0(\mathbf{A})$ is the number of zero entries in matrix \mathbf{A} and $per(\mathbf{A})$ is the permanent of matrix \mathbf{A} [36], there are at least $\mathcal{L}(n)/(n-d)!$ different parity-check matrices for Latin square LDLCs with the given generating set \mathcal{H} . Thus, for successful decryption, the generating set \mathcal{H} should be replaced with the parity-check matrix \mathbf{H} as the secret key in [12]. In this way, since the position of each non-zero entry along with its value has to be saved, the memory consumption for saving \mathbf{H} is $nd(r + 2\lceil \log_2(n) \rceil)$ bits, where r is the maximum number of bits required for saving h_i , for $i = 1, \dots, d$.

The secret key of the proposed LDLC based scheme is $\mathcal{K} = \{\mathcal{H}, \mathcal{P}\}$, where $\mathcal{P} = \{p_1, p_2, \dots, p_d\}$ is the set of indexes such that $1 \leq p_i \leq n$, for $1 \leq i \leq d$ [12]. Therefore, the key size of an LDLC based cryptosystem, when considering the parity-check matrix \mathbf{H} , is at most $d(n(r + 2\lceil \log_2(n) \rceil) + \lceil \log_2(n) \rceil)$ bits. In the same level of security (128 bits), the key size of the LDLC based cryptosystem for an LDLC with parameters $n = 10^4$, $d = 7$ and $r = 16$ is 3080098 bits; while the key size for our cryptosystem is equal to 214 bits with a (258, 215)-QC-LDPC code, $b = q = 43$, $d_v = 3$, $n_0 = 6$ and $d_c = 18$ that is much smaller. As a consequence, our proposed cryptosystem has a small key size compared to other RN-like cryptosystems that can also do modulation simultaneously.

VIII. CONCLUSION

In this paper, we have proposed a new RN-like encryption scheme using QC-LDPC lattices. Moreover, we have exploited lattice codes related to these lattices to join encryption, channel coding and modulation in a single step that is suitable for resource limited applications. The proposed nonlinear cryptosystem is secure against all variants of chosen plaintext attacks against RN-like encryption schemes. The main advantages of the proposed scheme are its high information rate, small key size and low hardware complexity. As a consequence, the joint scheme provides high speed and efficient implementation as well as secure and reliable data transmission for bandlimited AWGN channels.

REFERENCES

- [1] T. N. R. Rao, *Joint encryption and error correction schemes*, Proc. 11th annual International Symp. on Computer Architecture, ISCA'84, pp. 240–241, 1984.

- [2] T. N. R. Rao and K. H. Nam, *A private-key algebraic-coded cryptosystem*, In: Advances in Cryptology, Crypto'86, LNCS, **263**, pp. 35–48, Springer Berlin Heidelberg, 1986.
- [3] T. N. R. Rao and K. H. Nam, *Private-key algebraic-code encryptions*, IEEE Trans. Inf. Theory, **35**, pp. 829–33, 1989.
- [4] R. Struik and J. Tilburg, *The Rao-Nam scheme is insecure against a chosen-plaintext attack*, In: Advances in Cryptology, Crypto'87, LNCS, **293**, pp. 445–457, Springer Berlin Heidelberg, 1988.
- [5] A. I. Barbero and O. Ytrehus, *Modifications of the Rao-Nam cryptosystem*, In Proceedings of International Conf. on Coding Theory, Crypto. and Related Areas (ICCC98), pp. 1–13.
- [6] A. A. Sobhi Afshar, T. Eghlidos and M. R. Aref, *Efficient secure channel coding based on quasi-cyclic low-density parity-check codes*, IET Comm., **3**, pp. 279–292, 2009.
- [7] R. Hooshmand, T. Eghlidos and M. Aref, *Improving the Rao-Nam secret key cryptosystem using regular EDF-QC-LDPC codes*, ISeCure, **4**, no. 1, pp. 3–14, 2012.
- [8] M. Esmaili, M. Dakhilalian and T.A. Gulliver, *New secure channel coding scheme based on randomly punctured quasi-cyclic low-density parity check codes*, IET Comm., **8**, no. 14, pp. 2556–2562, 2014.
- [9] M. Esmaili and T. A. Gulliver, *Joint channel coding-cryptography based on random insertions and deletions in QC-LDPC codes*, IET Comm., **9**, no. 12, pp. 1555–1560, 2015.
- [10] M. Esmaili and T. A. Gulliver, *A secure code based cryptosystem via random insertions, deletions, and errors*, IEEE Comm. Letters, **20**, no. 5, pp. 870–873, 2016.
- [11] N. Sommer, M. Feder and O. Shalvi, *Low-Density Lattice Codes*, IEEE Trans. Inf. Theory, **54**, pp. 1561–1586, 2008.
- [12] R. Hooshmand and M. R. Aref, *Efficient secure channel coding scheme based on low-density Lattice codes*, IET Comm., **10**, no. 11, pp. 1365–1373, 2016.
- [13] T. A. Berson, *Failure of the McEliece public-key cryptosystem under message-resend and related-message attack*, In: Advances in Cryptology, CRYPTO'97, LNCS.
- [14] T. Hwang and T. Rao, *Secret error-correcting codes (SECC)*, in Proceedings of the 8th annual international Cryptology Conf. on Advances in Cryptology, CRYPTO'88, LNCS 403, pp. 540–563, 1990.
- [15] O. Adamo, F. Shengli and M. R. Varanasi, *Physical Layer Error Correction Based Cipher*, IEEE Global TeleComm. Conf., GLOBECOM'10, pp. 1–5.
- [16] Q. Chai and G. Gong, *Differential Cryptanalysis of Two Joint Encryption and Error Correction Schemes*, IEEE Global TeleComm. Conf., GLOBECOM'11, Houston, TX, USA, pp. 1–6.
- [17] C. M. Stuart and P. P. Deepthi, *Nonlinear Cryptosystem Based on QC-LDPC Codes for Enhanced Security and Reliability with Low Hardware Complexity and Reduced Key Size*, Wirel. Pers. Comm., pp. 1–21, 2017.
- [18] C. N. Mathur, K. Narayan, and K. Subbalakshmi, *High diffusion cipher: Encryption and error correction in a single cryptographic primitive*, in Applied Crypto. and Network Security, Springer Berlin Heidelberg, pp. 309–324, 2006.
- [19] E. Pisek, S. Abu-Surra, R. Taori, J. Dunham and D. Rajan, *Enhanced Cryptocoding: Joint Security and Advanced Dual-Step Quasi-Cyclic LDPC Coding*, IEEE Global Comm. Conf., GLOBECOM'15, San Diego, CA, pp. 1–7.
- [20] G. Ungerboeck, *Channel coding with multilevel/phase signals*, IEEE Trans. Inf. Theory, **28**, no. 1, pp. 55–67, 1982.
- [21] G. D. Forney and G. Ungerboeck, *Modulation and coding for linear Gaussian channels*, IEEE Trans. Inf. Theory, **44**, no. 6, pp. 2384–2415, 1998.
- [22] J. H. Conway and N. J. A. Sloane, “Sphere Packing, Lattices and Groups,” 3rd edition, Springer-Verlag, New York, 1998.
- [23] M.-R. Sadeghi and D. Panario, *Low-Density Parity-Check lattices based on Construction D' and cycle-free Tanner graphs*, Algebraic Coding Theory and Info. Theory, AMS DIMACS, **28**, pp. 85–95, 2005.
- [24] M.-R. Sadeghi, A. H. Banihashemi and D. Panario, *Low-Density Parity-Check Lattices: construction and decoding analysis*, IEEE Trans. Inf. Theory, **52**, pp. 4481–4495, 2006.

- [25] L. Safarnejad, M.-R. Sadeghi, *FFT based sum-product algorithm for decoding LDPC lattices*, IEEE Comm. Letters **16**, no. 9, pp. 1504–1507, 2012.
- [26] H. Khodaiemehr, D. Kiani and M.-R. Sadeghi, *One-Level LDPC Lattice Codes for the Relay Channels*, Iran Workshop on Comm. and Inf. Theory, IWCIT 2015.
- [27] H. Khodaiemehr, M.-R. Sadeghi and A. Sakzad, *Practical Encoder and Decoder for Power Constrained QC LDPC-lattice Codes*, IEEE Trans. Comm., **65**, no. 2, pp. 486–500, 2017.
- [28] H. Khodaiemehr, D. Kiani and M.-R. Sadeghi, *LDPC Lattice Codes for Full-Duplex Relay Channels*, IEEE Trans. Comm., **65**, no. 2, pp. 536–548, Feb. 2017.
- [29] H. Khodaiemehr, M.-R. Sadeghi, and D. Panario, *Construction of fulldiversity 1-level LDPC lattices for block-fading channels*, in IEEE International Symp. on Inf. Theory, ISIT'16, Barcelona, Spain, July 10-15, pp. 2714–2718.
- [30] K. Bagheri, M.-R. Sadeghi, T. Eghlidos and D. Panario, *A secret key encryption scheme based on 1-level QC-LDPC lattices*, In Proc. of 13th International ISC (Iranian Society of Cryptology) Conf. on Inf. Security and Cryptology (ISCISC'16), IEEE, pp. 20–25.
- [31] K. Bagheri, M.-R. Sadeghi and T. Eghlidos, *An Efficient Public Key Encryption Scheme Based on QC-MDPC Lattices*, in IEEE Access, vol. **5**, pp. 25527–25541, 2017.
- [32] M.-R. Sadeghi and A. Sakzad, *On the performance of 1-level LDPC lattices*, Iran Workshop on Comm. and Inf. Theory (IWCIT 2013), pp. 1–5, 2013.
- [33] M. Baldi, “QC-LDPC Code-Based Cryptography,” Springer, Berlin, 2014.
- [34] G. L. Mullen, and D. Panario, Handbook of Finite Fields, Chapman & Hall/CRC, 2013.
- [35] M.R. Darafsheh, *Order of elements in the groups related to the general linear group*, Finite Fields and Their Applications, **11**, no. 4, pp. 738–747, 2005.
- [36] J.-Y. Shao and W.-D. Wei, *A formula for the number of Latin squares*, Discrete Mathematics, **110**, pp. 293–296, 1992.
- [37] P.-P. Deepthi and P.-S. Sathidevi, *Hardware stream cipher based on LFSR and modular division circuit*, International Journal of Electronics, Circuits and Systems, **2**, 224–232, 2008.
- [38] D. Mukhopadhyay and D. R. Chowdhury *A parallel efficient architecture for large cryptographically robust $n \times k$ ($k > n/2$) Mappings*, IEEE Trans. on Computers, **60**, no. 3, pp. 375–385, 2011.
- [39] X. Lai, *Higher order derivatives and differential cryptanalysis*, Proceedings of the Symp. on Comm., Coding and Crypto., pp. 227–233, 1994.