

# CoRT: A Communication Robustness Testbed for Industrial Control System Components

Matthias Niedermaier  
Hochschule Augsburg

Augsburg, Germany  
Matthias.Niedermaier@hs-augsburg.de

Alexander von Bodisco  
Hochschule Augsburg

Augsburg, Germany  
Alexander.vonBodisco@hs-augsburg.de

Dominik Merli  
Hochschule Augsburg

Augsburg, Germany  
Dominik.Merli@hs-augsburg.de

*Abstract*—The number of interconnected devices is growing constantly due to rapid digitalization, thus providing attackers with a larger attack surface. Particularly in critical infrastructures and manufacturing, where processes can be observed and controlled remotely, successful attacks could lead to high costs and damage. Therefore, it is necessary to investigate Industrial Control System (ICS) devices like Programmable Logic Controllers (PLCs) to make these sectors more secure. One possible attack vector is the exploitation of the network communication of devices. Thus, a robust communication system is essential to ensure security. Unfortunately, the high demand for real-world ICSs makes it difficult to assess component security during its runtime. However, this is possible in a research testbed where tests could be done and analyzed in a safe environment. In this paper, we introduce our testbed and measurement methods for communication robustness test research of ICS components.

*Index Terms*—testbed, industrial control system, communication robustness test

## I. INTRODUCTION

Digitization is happening steadily, meaning that more and more devices are getting interconnected. This trend of connected devices can be observed also in industrial environments and in critical infrastructure sectors. Consequently, the attack surface over networks is also growing constantly. A successful attack on industrial plants such as critical infrastructures results in high costs and damage. Hence, the security of the devices used in these applications must be ensured and should be provided by the devices themselves. Owing to remote access, security audits should also focus on robust and secure network communication. However, a penetration test in a real-world production environment could lead to damage and outage. Therefore, to analyze the communication robustness of these components, a testbed is necessary.

There are already a lot of testbeds for Industrial Control System (ICS) security research. Holm et al. [1] have analyzed 30 ICS testbeds in 2015. However, these mostly focus on analyzing a complete ICS infrastructure, as opposed to testing single components.

In this paper, we present our testbed, focusing on the security of industrial components, especially the robustness of communication, which can influence the control behavior. The following requirements for the testbed, with corresponding measurement methods, have been defined:

- **Network capture:** The generated network traffic during attacks and tests must be captured for further investigation.
- **Network reachability check:** It must be probed if the devices are reachable within the network during attacks.
- **Electrical monitoring:** The electrical outputs must be monitored to recognize changes in the control behavior.
- **Fast integration:** The integration of new devices into the testbed must be easy and fast.

The rest of the paper is structured as follows. In Section II, an overview of the testbed is given. The devices currently deployed in the testbed are described in Section III. Security tests, which can be done with CoRT, are explained in Section IV. Finally, a conclusion is provided in Section V.

## II. CoRT TESTBED

A communication robustness test measures the steadiness of control signals under various communication parameters and loads. Fig. 1 shows our testbed divided into two identical racks, enabling comparison of the results.

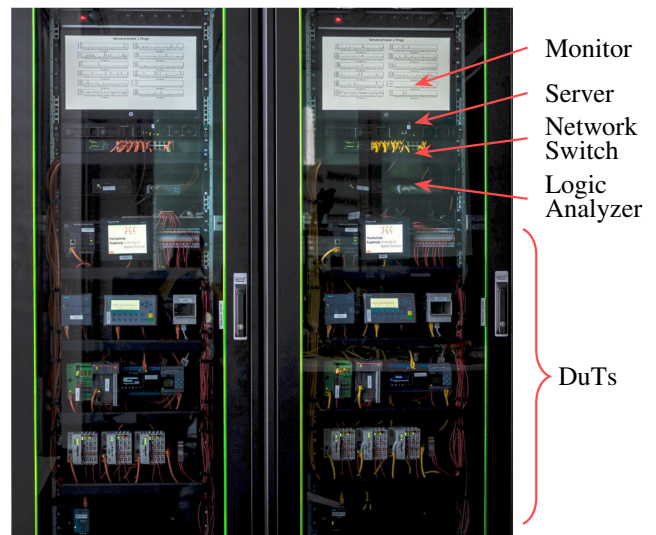

Fig. 1. Picture of the Testbed Built into Racks

At the bottom are the Devices under Test (DuTs), such as Programmable Logic Controllers (PLCs), Human Machine

Interfaces (HMIs), and bus couplers. The electrical outputs of these are wired to a logic analyzer. All DuTs are interconnected with a network switch to a server. Furthermore, there is a monitor built in to keep tabs on the analyzed data. The DuTs are mounted on an EN 50022 rail, which is commonly used in the industrial sector. Both racks are lockable and have wheels for easy transportation.

#### A. Attacker Model

This testbed is focused on, but not limited to, two attacker models: a) an attacker who has remote access to the network and b) an attacker who has local access to the ICS components with basic knowledge. Both of them are able to inject network traffic, e.g. to send commands or perform a Man-in-the-Middle (MitM) attack. Attacker model b is furthermore able to locally manipulate input signals and has direct network access to the DuT.

#### B. Robustness of Devices

The robustness of an Industrial Internet of Things (IIoT) device is essential, because they mostly control machines and interact with their environment. Therefore, an outage or loss of control creates a problem. With the CoRT, the research question of how network communication could influence the robustness of industrial systems can be analyzed. The communication robustness of different industrial components can be measured with fuzz testing frameworks. Besides, these must be specialized for proprietary protocol fuzzing in ICSs, such as PropFuzz [2].

#### C. Schematic Overview of the Testbed

Fig. 2 gives a schematic overview of the testbed components. On the server, there are three Virtual Machines (VMs) for measuring, programming, and attacking the DuTs. In order not to influence the measurement, this separation is necessary, because some attack tools produce a high system load. Furthermore, additional attack tools and further DuTs could be integrated into the testbed.

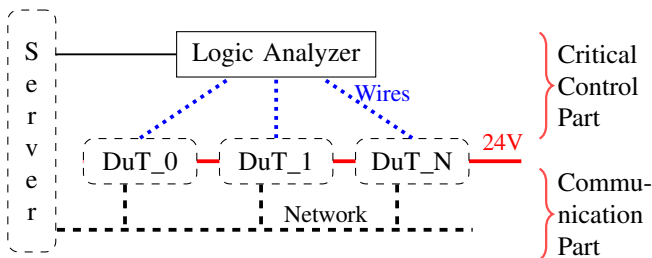

Fig. 2. Schematic Overview of the Testbed

The DuTs are powered by 24V, which can be switched on and off remotely by the measurement VM. With the logic analyzer, the critical control part is observed.

#### D. Electrical Behavior

To measure the robustness of the DuTs, the electrical outputs are observed with a logic analyzer. All PLCs are configured to toggle every single cycle, resulting in a frequency between 20Hz and 20kHz depending on the device. These signals are measured with a logic analyzer and logged on the measurement VM. For the logic analyzer task, a BeagleBone Green running Beaglelogic [3] with a custom Printed Circuit Board (PCB) is used. Using BeagleLogic, it is possible to measure a sample frequency up to 100MHz. Fig. 3 shows the adapter board designed by us.

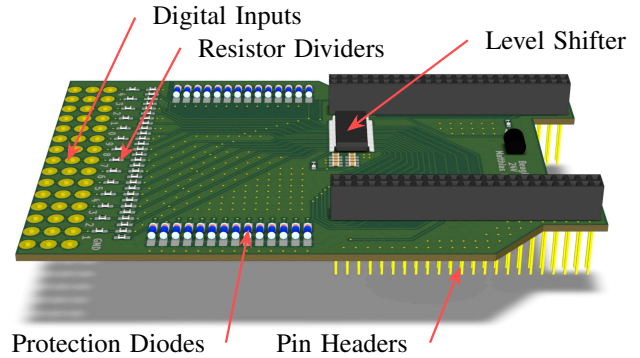

Fig. 3. Rendered Image of the PCB of the Logic Adapter Board

This is necessary to measure up to 30V and convert it to the 3.3V input signal of the BeagleBone Green. On the PCB, there are mainly resistor dividers, protection diodes, and an SN74LVCH16245A [4] 16-Bit level shifter. The left side of the PCB is connected to the outputs of the DuTs and the pin header is mounted on the BeagleBone Green. With the logic analyzer setup, influences on the control behavior of PLCs are measured and logged.

#### E. Ping Response

To ensure network reachability during the tests, the ping response of all devices is measured. This is done with a fping [5] script every 100ms, which has been tested as a trade-off between measuring accuracy and not influencing the devices by flooding. If a network stack on a DuT crashes, it is detected and logged.

#### F. Network Capture

To analyze tests in detail, a network capture of this period is essential. The complete network traffic within the testbed is mirrored on one port and captured with tcpdump [6] in a log rotation. For example, if a device fails during an attack, the timestamped and corresponding captures are used for further investigation.

#### G. Visualization

Besides the logging, the measurement results are directly visualized on monitors on the testbed. The cycle time [7] of a Siemens S7-1211C during idle is illustrated in Fig. 4. But this is not constant, because it is influenced by communication

and housekeeping during the execution. One scan cycle takes from  $140\mu\text{s}$  to  $300\mu\text{s}$  during idle measurement. This can later be compared with the scan cycle time during an attack, e.g. to check if the DuT is being influenced.

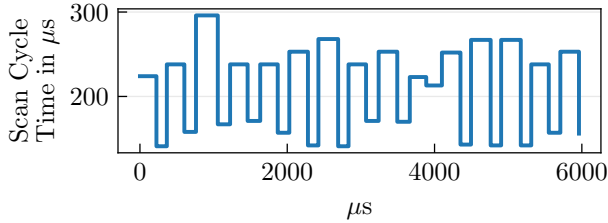

Fig. 4. Visualization of the Scan Cycle Time of a Siemens S7-1211C

Furthermore, the ping response, current test results, and statistics of the network capture are visualized. This enables a quick overview at any time.

#### H. Virtualized Devices

For the measurement of the response time of a command sent over the network to the DuT, it is necessary to virtualize components, e.g. sensors or other IIoT devices. The control command (e.g. set an output over an industrial protocol) is sent by the measurement VM, which reduces timing dependencies during the measurement. Thereafter, the electrical output is measured by the logic analyzer and is processed. In order to send a command, the industrial protocol, e.g. BACnet and Modbus, must be used and implemented into the test.

#### I. Input Signal Generation

To simulate electric input signals for the DuTs, these must be generated to be read by real hardware. This is realized with a Universal Serial Bus (USB)-to-serial converter. Both the generated input and output signals of the DuT are measured by the logic analyzer. The delay between them is the response time. A jitter of this could be caused if, for example, the DuT faces a high Central Processing Unit (CPU) load due to network communication.

### III. DUTS IN THE TESTBED

For the CoRT testbed, diverse vendors and products have been chosen. With this, it is possible to compare implementations based on their security level from a technical point of view. However, single devices can also be tested. Table I lists currently employed devices with a selection of open ports.

#### A. Common Network Protocols

Industrial components often use common network protocols for tasks such as monitoring and visualization. On the testbed, we have the following common network protocols:

- **File Transfer Protocol (FTP) "Port: 21"** is used for file transfer. Within industrial networks, this is used for logging and updating the firmware, for example.
- **Secure Shell (SSH) "22"** refers to a network protocol that can be used to securely communicate with a remote

device. It is often used to make a remote command line available locally if, for example, the PLC runs Linux.

- **Telnet "23"** is a client/server protocol that is based on a character-oriented data exchange over a TCP connection. PLCs could be partly configured over it.
- **Hypertext Transfer Protocol (HTTP) "80"** is mainly used to load web pages (hypertext files) into a web browser. **Hypertext Transfer Protocol Secure (HTTPS) "443"** uses an additional transport security. These are used for the visualization of diagnostic information and sensor values.

#### B. Industrial Network Protocols

In modern plants, fieldbuses are increasingly being replaced by an IP-based communication system. Within CoRT, five common industrial protocols on real hardware are available.

- The **Modbus/TCP "502"** protocol is a communication protocol based on a master/slave architecture.
- **KNX IP "3671"** is mostly used for building automation.
- **OPC Unified Architecture "4840"** is an industrial Machine to Machine (M2M) communication protocol that works across manufacturers.
- **Ethernet/IP "44818"** is a real-time Ethernet mainly used in automation technology.
- **BACnet/IP "47808"** is mostly used in building automation, ensuring interoperability between devices of different manufacturers, if all partners agree on certain building blocks defined by the standard.

#### C. Proprietary Network Protocols

Furthermore, there are proprietary protocols, which are only partly understood. The **S7comm "102"** protocol is used by Siemens devices to communicate, for example, with the Integrated Development Environment (IDE) and HMIs. Moreover, other vendors use proprietary protocols to program PLCs and HMIs (**Phoenix Contacts "1962, 41100"**, **ABB "1200, 1201"**, **WinCC "2308"**, **WAGO-Service-Protocol "2455, 6626"**, **Crouzet "42424"**, **Codesys "11740"**). In terms of security, these protocols are particularly interesting, because they execute privileged commands, such as setting the run mode of a device and updating the user application.

### IV. EXPERIMENTS WITH CORT

With CoRT, a playground for researchers, organizations, and academic collaborators is made available. It is nearly impossible to make tests in an operating ICS, let alone change hardware or software. Even if tests can be performed, the bulk of the necessary data is not recorded and cannot be evaluated.

To evaluate different DuTs, predefined sequences of tests are used. One of these test sequences is illustrated in Fig. 5. After it starts, an automated power cycle of the DuT can be done. This becomes necessary if previous tests have influenced the DuT or if it does not recover, e.g. after a successful Denial of Service (DoS) attack. Afterward, the measurement begins, including network captures, continuous reachability

TABLE I  
PLCs CURRENTLY EMPLOYED WITHIN THE TESTBED

Vendor	Product	Vendor No.	IP Rack 1	IP Rack 2	Selection of Open Ports
Siemens	CPU 1211C	6ES7211-1AE40-0XB0	192.168.0.10	192.168.0.110	80, 102, 443
Siemens	KP 300	6AV6647-0AH11-3AX0	192.168.0.11	192.168.0.111	102, 2308
Phoenix	ILC 151	2700974	192.168.0.20	192.168.0.120	21, 80, 1962, 41100
ABB	PM554-T	1SAP120600R0071	192.168.0.21	192.168.0.121	21, 502, 1200, 1201
Crouzet	em4 B26-2GS	88981133	192.168.0.22	192.168.0.122	502, 42424
Siemens	LOGO! 24RCE	6ED1052-1CC01-0BA8	192.168.0.23	192.168.0.123	80, 102, 502, 8080
Wago	Controller KNX IP	750-889	192.168.0.30	192.168.0.130	21, 80, 443, 502, 2455, 6626
Wago	Controller PFC100	750-8100	192.168.0.31	192.168.0.131	22, 80, 443, 502, 4840, 6626, 11740
Wago	Controller ETHERNET	750-880	192.168.0.32	192.168.0.132	21, 80, 443, 502, 2455, 6626, 44818
Wago	Controller BACnet/IP	750-831	192.168.0.33	192.168.0.133	21, 80, 443, 502, 2455, 6626, 47808
Schneider	TM221CE16T	TM221CE16T	192.168.0.50	192.168.0.150	502, 44818
Schneider	HMISTU855	HMISTU855	192.168.0.51	192.168.0.151	502, 6001
OpenPLC v2 [8]	Raspberry Pi 3	Commit f1a2645	192.168.0.60	192.168.0.160	22, 502, 8080, 20000
Moxa	NP5110	NP5110	192.168.0.70	192.168.0.170	23, 80, 443, 950, 966, 4900

check, and electrical output measurement. The measurement process has three phases: (1) pre-idle, (2) attack, and (3) post-idle monitoring.

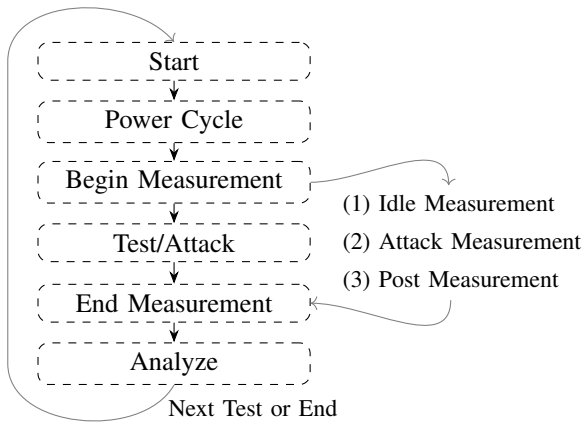

Fig. 5. Illustration of a Test Sequence

During the test/attack, the DuT is penetrated with different kinds of network robustness tests and vulnerability scans. Finally, the results are analyzed, logged, and are visualized on the monitor. If additional tests are in the queue, the sequence starts from the beginning until all tests are finished. It is possible to perform a full test on a single device, or to apply one test on every device in the rack. This depends on the type of validation, such as fuzzing of a single protocol on a device, which are not supported by other DuTs. Our first measurements indicate that network traffic can influence devices.

## V. CONCLUSION

The proposed testbed is a combination of network devices, measurement equipment, and industrial components. It allows

studying ICS devices like PLCs, sensors, and HMIs in detail without influencing real-world processes. Furthermore, the testbed measurements are automatically recorded and analyzed, where new test scenarios can build up, without having to worry about the measurement setup. With this testbed, a basis for communication robustness tests has been built.

## ACKNOWLEDGMENT

The work of the CoRT forms part of the RiskViz [9] research project, which is funded by the Federal Ministry of Education and Research (BMBF), with the aim of creating ICS risk map.

## REFERENCES

- [1] H. Holm, M. Karresand, A. Vidström, and E. Westring, "A Survey of Industrial Control System Testbeds," 2015.
- [2] M. Niedermaier, F. Fischer, and A. von Bodisco, "PropFuzz - An IT-security Fuzzing Framework for Proprietary ICS Protocols," in *2017 International Conference on Applied Electronics (AE), Pilsen*, pp. 1–4, 2017.
- [3] K. Abhishek, "Beaglelogic - Beaglebone Logic Analyzer." Online: <https://github.com/abhishek-kakkar/BeagleLogic/wiki>. Accessed: 2018-04-17.
- [4] Texas Instruments, "Datasheet: SN74LVCH16245A 16-bit Bus Transceiver With 3-state Outputs." Online: <http://www.ti.com/lit/ds/symlink/sn74lvch16245a.pdf>. Accessed: 2018-04-17.
- [5] D. Schweikert, "fping." Online: <https://fping.org/>. Accessed: 2018-04-18.
- [6] V. Jacobson, C. Leres, and S. McCanne, "The tcpdump manual page," *Lawrence Berkeley Laboratory, Berkeley, CA*, vol. 143, 1989.
- [7] A. Mader, "A Classification of PLC Models and Applications," in *Discrete Event Systems*, pp. 239–246, Springer, 2000.
- [8] T. R. Alves, M. Buratto, F. M. de Souza, and T. V. Rodrigues, "OpenPLC: An Open Source Alternative to Automation," in *Global Humanitarian Technology Conference (GHTC), 2014 IEEE*, pp. 585–589, IEEE, 2014.
- [9] "Riskviz." <https://www.riskviz.de>. Accessed: 05.04.2018.