

Performance Modeling of Microservice Platforms

Hamzeh Khazaei, *Member, IEEE*, Nima Mahmoudi, *Student Member, IEEE*, Cornel Barna, *Member, IEEE*, and Marin Litoiu, *Senior Member, IEEE*

Abstract—Microservice architecture has transformed the way developers are building and deploying applications in the nowadays cloud computing centers. This new approach provides increased scalability, flexibility, manageability, and performance while reducing the complexity of the whole software development life cycle. The increase in cloud resource utilization also benefits microservice providers. Various microservice platforms have emerged to facilitate the DevOps of containerized services by enabling continuous integration and delivery. Microservice platforms deploy application containers on virtual or physical machines provided by public/private cloud infrastructures in a seamless manner. In this paper, we study and evaluate the provisioning performance of microservice platforms by incorporating the details of all layers (i.e., both micro and macro layers) in the modelling process. To this end, we first build a microservice platform on top of Amazon EC2 cloud and then leverage it to develop a comprehensive performance model to perform what-if analysis and capacity planning for microservice platforms at scale. In other words, the proposed performance model provides a systematic approach to measure the elasticity of the microservice platform by analyzing the provisioning performance at both the microservice platform and the back-end macroservice infrastructures.

Index Terms—performance modeling, microservice platforms, containers, cloud infrastructure and stochastic processes.



1 INTRODUCTION

VIRTUAL Machines (VM) are a widely used building block of workload management and deployment. They are heavily used in both traditional data center environments and clouds. A hypervisor is usually used to manage all virtual machines on a physical machine. This virtualization technology is quite mature now and can provide good performance and security isolation among VM instances. The isolation among VMs is strong, and an individual VM has no awareness of other VMs running on the same physical machine (PM). However, for applications that require higher flexibility at runtime and less isolation, hypervisor-based virtualization might not satisfy the entire set of quality of service (QoS) requirements.

Recently there has been an increasing interest in container technology, which provides a more lightweight mechanism by way of operating system level virtualization compared to VMs [1]. A *container* runs on a kernel with similar performance isolation and allocation characteristics as VMs but without the expensive VM runtime management overhead [2]. Containerization of applications, which is the deployment of application or its components in containers, has become popular in the cloud service industry [3], [4], [5]. For example, Google, Amazon, eBay and Netflix are providing many of their popular services through a container-based cloud [6].

A popular containerization engine is *Docker* [7], which wraps an application in a complete filesystem that contains everything

required to run: code, runtime, system tools, and system libraries – anything that can be installed on a VM. This guarantees that the application will always run the same, regardless of its runtime environment [7]. Container-based services are popularly known as *Microservices* (while VM based services are referred to as *Macroservices*) and are being leveraged by many service providers for a number of reasons: (a) reduced complexity for tiny services; (b) easy and fast scalability and deployment of application; (c) improvement of flexibility by using different tools and frameworks; (d) enhanced reliability for the system [6]. Containers have empowered the usage of microservices architectures by being lightweight, providing fast start-up times, and having low overhead. Containers can be used to develop *monolithic architectures* where the whole system runs inside a single container or *clustered architectures*, where a combination of containers is used [8].

A flexible computing model combines Infrastructure-as-a-Service (IaaS) structure with container-based Platform-as-a-Service (PaaS). Leveraging both containers and VMs brings the best of both technologies for all stakeholders: the strong isolation of VM for the security and privacy purposes, and the flexibility of containers to improve performance and management. Platforms such as Tutum [9], Kubernetes [10], Nirmata [11] and others [12], [13] offer services for managing microservice environments made of containers while relying on IaaS public/private clouds as the backend resource providers. Application service providers who plan to migrate to microservice platforms need to know how their QoS would be at scale. Service availability and service response time are among the top two key QoS metrics [14]. Quantifying and characterizing such quality measures require accurate modelling and coverage of large parameter space while using tractable and solvable models in a timely manner to assist with runtime decisions [15]. Scalability is a key factor in the realization of availability and responsiveness of a distributed application in times of workload fluctuation and component failure. In other words, the method and delay at which an application can provision and deprovision resources determine the service response time and availability.

- H. Khazaei is with the Department of Electrical Engineering and Computer Science, York University, Toronto, Ontario, Canada.
E-mail: hkh@yorku.ca
- N. Mahmoudi is with the Department of Electrical and Computer Engineering, University of Alberta, Edmonton, Alberta, Canada.
E-mail: nmahmoud@ualberta.ca
- C. Barna is with Seneca Collage.
- M. Litoiu is with the Department of Electrical Engineering and Computer Science, York University, Toronto, Ontario, Canada.
E-mail: mlitoiu@yorku.ca

Manuscript received April XX, 2020; revised August XX, 2020.

In this work, we build a microservice platform using the most widespread technology, i.e. Docker [7], and then leverage this platform to design a tuneable analytical performance model that provides what-if analysis and capacity planning at scale. Both microservice platform providers and microservice application owners may leverage the performance model to measure the quality of their elasticity in terms of provisioning and deprovisioning resources. The proposed performance model is comprehensive as it models both microservice as well as the macroservice layers through separate but interactive sub-models. The performance model supports a high degree of virtualization at both layers (i.e., multiple VMs on a PM and multiple containers on a VM) that reflects the real use case scenarios in today's microservice platforms. It is worth mentioning that in this paper the focus is on the provisioning performance of the microservice platform and not the performance of deployed applications. A preliminary version of this work appeared as a conference paper [8], which only models the microservice layer and treats the back-end IaaS cloud as a black box. In this work, however, we propose a comprehensive fine granular performance model that captures the details of both layers and their interactions; we discuss the scalability and tractability and also provide an algorithm that presents the internal logic of the performance model.

The rest of the paper is organized as follows. Section 2 describes the virtualization techniques and the new trend of emerging microservices. Section 3 describes the system that we are going to model in this work. Section 4 introduces the stochastic sub-models and their interactions. Section 5 presents the experiments and numerical results obtained from the analytical model. In section 6, we survey related work in cloud performance analysis, and finally, section 7 summarizes our findings and concludes the paper.

2 VIRTUALIZATION AND MICROSERVICES

The concept of virtualization was created with the main goal of increasing the efficient use of computing resources. With the advent of cloud computing, virtualization has received even more attention for managing cloud data centers. Cloud providers essentially employ two main components, cloud management systems and hypervisors, to manage their physical stack of resources and make it accessible to a large number of users. Hypervisors provide a well defined logical view of the physical resources of a single physical machine (PM). Cloud management systems, on the other hand, provide a single interface of management for both service providers and cloud users of the whole data center. This way, cloud resources are provided to users as virtual machines (VMs), highly isolated environments with a full operating system. The most popular hypervisors are VMware [16], KVM [17], Xen [18] and Hyper-V [19]; and popular open-source cloud management systems include OpenStack [20], CloudStack [21], and Eucalyptus [22]. Hypervisor-based virtualization provides the highest isolated virtual environment. However, the cost of virtualization overhead is high, as each VM has to run its own kernel as the Guest OS. Moreover, VM resources are mainly underutilized, as each VM usually hosts one application [23]. VM virtualization limitations led to the development of Linux containers wherein only resources required by applications will be used while avoiding the overhead of redundant virtualized operating systems, as is the case in VMs.

A Linux container takes a different approach than a hypervisor and could be used as an alternative to or a complement for hypervisor-based virtualization. Containerization is an approach

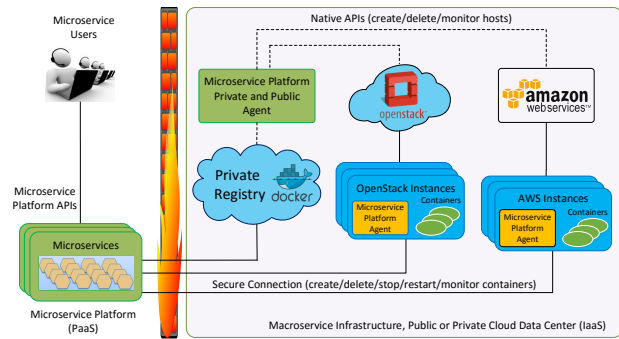

Fig. 1. Conceptual Model: including both the microservice platform and macroservice infrastructure (i.e., backend public/private cloud) [8].

where one can run many processes in an isolated fashion. It uses only one kernel (i.e., OS) to create multiple isolated environments. Containers are very lightweight because they do not virtualize the hardware; instead, all containers on the physical host use the single host kernel efficiently via process isolation. Containers are highly portable, and applications can be bundled into a single unit and deployed in various environments without making any changes to the container. Because of the standard container format, developers only have to worry about the applications running inside the container and system administrators will take care of deploying the container onto the servers. This well-segregated container management leads to faster application delivery. Moreover, building new containers is fast because containers are very lightweight, and it takes seconds to build a new container. This, in turn, reduces the time for DevOps, including development, test, deployment and runtime operations [24]. All in all, containers not only lead to significant improvements in the software development life cycle in the cloud, but also provide a better QoS compared to non-containerized cloud applications. Several management tools are available for Linux containers, including LXC [25], lmtctfy [26], Warden [27], and Docker [7].

Recently, a pattern has been adopted by many software-as-a-service providers in which both VMs and containers are leveraged to provide so-called *microservices*. Microservices is an approach that allows more complex applications to be configured from basic building blocks, where each building block is deployed in a container, and the constituent containers are linked together to form the cohesive application. The application's functionality can then be scaled by deploying more containers of the appropriate building blocks rather than entire new instances of the full application. *Microservice platforms* (MSP) such as Nirmata [11], Docker Cloud [9] and Google Kubernetes [10] facilitate the management of such service paradigms. MSPs are automating deployment, scaling, and operations of application containers across clusters of physical machines in the cloud. MSPs enable Software-as-a-Service (SaaS) providers to quickly and efficiently respond to customer demand by scaling the applications on-demand, seamlessly rolling out new features, and optimizing hardware usage by using only the resources that are needed. Fig. 1 depicts the high-level architecture of MSPs and the way they leverage the backend public or private cloud (i.e., infrastructure-as-a-service clouds).

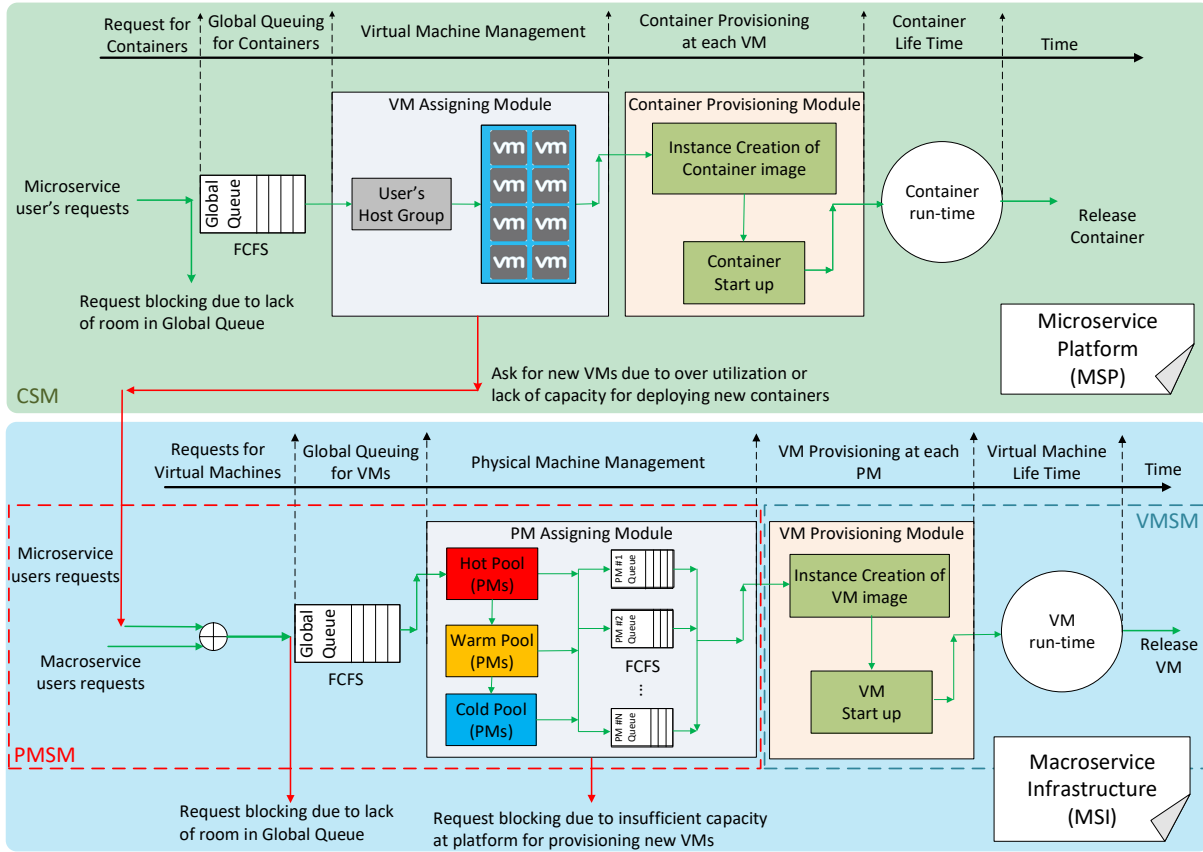

Fig. 2. The master performance model, derived from conceptual model in Fig. 1. The three sub-systems reflected in the performance model by each of the sub-models (CSM, PMSM, and VMSM) are annotated in the figure.

3 SYSTEM DESCRIPTION

In this section, we describe the system under modelling with respect to Fig. 2 that has been derived from the conceptual model shown in Fig. 1. First, we describe the microservice platform (MSP) in which users request containers. In MSP, a request may originate from two sources: 1) direct requests from users that want to deploy a new application or service; and 2) runtime requests either directly from users or from applications (e.g., consider adaptive applications) by which applications adapt to the runtime conditions, e.g., scaling up the number of containers to cope with a traffic peak. In the proposed performance model, this platform is modelled by the container sub-model (CSM).

Now consider a user, e.g., John, that wants to provide a new service for his customers. He would log into his MSP and create a Host Group with 2 initial VMs for the new services, setting the max size of host group to 5 VMs and each VM to run up to 4 containers. In other words, his host group can scale up to 5 VMs that can accommodate up to 20 containers in total. He requests 6 containers for the initial setup and deploys 3 containers on each VM. Now, John has 2 active VMs, each running 3 containers. His application is adaptive so that in case of high traffic, it will scale up by adding one container at a time. Consider a situation in which John’s application adds one more container to the application due to high traffic. At this time, one VM is working with full capacity (i.e., running 4 containers), and another one only has capacity for one more container. Since John has configured his cluster application to grow up to 5 VMs, the MSP requests a new VM

from the macroservice provider (i.e., IaaS) due to high utilization in the host group. Thus, John’s host group now has 3 active VMs and can accommodate 5 more containers. Now consider the reverse scenario in which low traffic is entering the system and the application releases a few of containers after some time. If the host group utilization reaches a predefined low threshold, then the MSP would release one VM. We capture all these events for every single user in a Continuous-Time Markov Chain (CTMC) that will be described in section 4.1.

The steps incurred in servicing a request in MSP are shown in the upper part of Fig. 2. User requests for containers are submitted to a global finite queue and then processed on a first come, first served (FCFS) basis. A request that finds the queue full will be rejected immediately. Also, the request will be rejected if the application has already reached its capacity (for example, in John’s scenario, if the host group already has 5 running VMs, each of which is running 4 containers). Once the request is admitted to the queue, it must wait until the VM Assigning Module (VMAM) processes it. VMAM finds the most appropriate VM in the user’s Host Group and then sends the request to that VM so that the Container Provisioning Module (CPM) initiates and deploys the container (second delay). When a request is processed in CPM, a pre-built or customized container image is used to create a container instance. These images can be loaded from a public repository like Docker Hub [7] or private repositories.

In the macroservice infrastructure (lower part in Fig. 2), when a request is processed, a pre-built or customized disk image is used

TABLE 1

Symbols and corresponding descriptions for microservice platform module.

Symbol	Description
MPM	Microservice Platform Module
CSM	Container Sub-Model
λ	Mean arrival rate to CSM
$1/\alpha$	Mean time that takes to obtain a VM
$1/\beta$	Mean time that takes to release a VM
s	Min number of active VM in user's Host Group
S	Max size of the user's host group (VMs)
M	Max number of containers running on a VM
$1/\mu$	Mean value of container lifetime
ϕ	The rate by which a container can be instantiated
u	Utilization in the user's Host Group
L_q	Microservice global queue size, $L_q = S * M$
bp_q	Blocking probability in the microservice global queue
λ_c	Arrival rate of requests for VMs originated from CSM
η_c	VM release rate imposed by CSM
wt_q	Mean waiting time in the microservice global queue

to create a VM instance [28]. In this work, we assume that pre-built images fulfill all user requirements and PMs and VMs are homogeneous. Each PM has a Virtual Machine Monitor (VMM), aka hypervisor, that configures and deploys VMs on a PM. In this work, we allow users to submit a request for a single VM at a time. Two types of requests are arriving at the Macroservice Infrastructure: 1) requests that are originating from the cloud users, which are referred to as Macroservice users in Fig. 2; and 2) requests from MSPs by which users/applications are asking for VMs to deploy/scale their containers. Self-adaptive applications in MSP might autonomously and directly ask for VMs from the backend cloud. Since the number of users/applications in MSP is relatively high, and they may submit requests for new VMs with low probability, the request process can be modelled as a Poisson process [29], [30]. The same story holds for external request processes at both MSP and backend cloud.

The steps incurred in servicing a request in *Macroservice Infrastructure* (MSI) are shown in the lower part of Fig. 2. User requests are submitted to a global finite queue, and then the scheduler processes them on an FCFS-basis. A request that finds the queue full will be rejected immediately. Once the request is admitted to the queue, it must wait until the scheduler in the Physical Machine Assigning Module (PMAM) processes it (first delay). As shown in Fig. 2, these steps are incorporated into the proposed performance model within the Physical Machine Sub-Model (PMSM). Once the request is assigned to one of the PMs, it will have to wait in that PM's input queue (second delay) until the VM Provisioning Module (VMPM) instantiates and deploys the necessary VM (third delay) before the start of the actual service. When a running request finishes, the capacity used by the corresponding VM is released and becomes available for servicing the next request. These processes and delays are addressed in the Virtual Machine Sub-Model (VMSM).

To model the behavior of this system, we design three stochastic sub-models: 1) Container Sub-Model (CSM); 2) Virtual Machine Sub-Model (VMSM); and 3) Physical Machine Sub-Model (PMSM). These sub-models are also shown in Fig. 2. Among the proposed sub-models, CSM captures the details of the microservice platform called Microservice Platform Module

TABLE 2

Symbols and corresponding descriptions for macroservice modules.

Symbol	Description
PMAM	Physical Machine Assigning Module
PMSM	Physical Machine Sub-Model
λ_x	Mean value of external request to PMSM
λ_a	Aggregate arrival rate to PMSM that is equal to $\lambda_c + \lambda_x$
BP_q	Blocking probability due to lack of room in the macroservice global queue
BP_r	Blocking probability due to lack of capacity in the cloud center
L_Q	Size of global input queues
$1/\alpha$	Mean lookup time in the pool
P_{reject}	Total probability of blocking ($BP_q + BP_r$)
P_s	Probability of successful search in pool
wt_Q	Mean waiting time in macroservice global queue
\bar{wt}	Mean lookup delay among pools
$\overline{PM_{wt}}$	Mean waiting time in a PM queue
VMPM	Virtual Machine Provisioning Module
VMSM	Virtual Machine Sub-Model
m	Max number of VMs that a PM is set to host; m is also the queue size in each PM
$1/\eta$	Mean value of VM lifetime
δ	The rate by which a VM can be instantiated
λ_h	Arrival rate to a PM in the pool
N	Number of PMs in the servers pool
\bar{pt}	Mean VM provisioning time
td	Mean total delay imposed on requests in macroservice infrastructure

TABLE 3

Modules and their corresponding sub-models.

Component	Module	Stochastic sub-model
Microservice Platform	MPM	CSM
Macroservice	PMAM	PMSM
Infrastructure	VMPM	VMSM

(MPM) and the other two (PMSM and VMSM) capture the details of the macroservice infrastructure, namely, Physical Machine Assigning Module (PMAM) and Virtual Machine Provisioning Module (VMPM). We implement each module with a stochastic sub-model. We combine all three stochastic sub-models and build an overall interactive performance model. Then, we solve this model to compute the cloud performance metrics: request rejection probability, probability of immediate service and mean response delay as functions of variations in workload (request arrival rate), container lifetime, users quota (i.e., host group size), number of container per VM and system capacity (i.e., number of PMs in cloud center). We describe our analysis in detail in the following sections, using the symbols and acronyms listed in Tables 1 and 2.

4 LAYERED ANALYTICAL MODEL

In this paper, we implement the sub-models using interactive Continuous Time Markov Chain (CTMC). These sub-models are interactive, such that the output of one model is input to the other ones and vice versa. Table 3 shows the modules and their corresponding stochastic sub-models, which will be discussed in detail in the following sections.

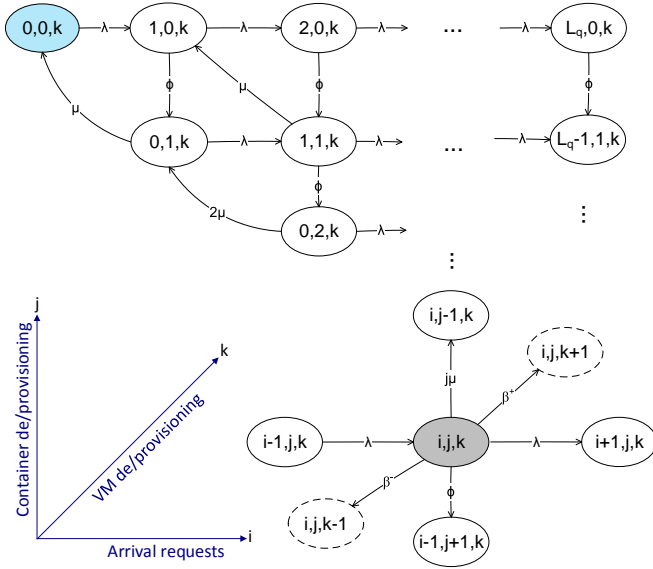

Fig. 3. Container Sub-Model (CSM).

4.1 Microservice Platform Module

The container allocation process in the microservice platform is described in the Container Sub-Model (CSM) shown in Fig. 3. CSM is a 3-dimensional CTMC with states that labelled as (i, j, k) where i indicates the number of requests in Microservice Global Queue, j denotes the number of running containers in the platform, and k shows the number of active VMs in the user's Host Group. In this work, we assume all inter-event periods are exponentially distributed. Each VM can accommodate up to M containers which is set by the user. Since the number of potential users is high and a single user typically submits requests at a moment in time with low probability, the requests' arrival can be adequately modelled as a Poisson process [31] with rate λ . Let ϕ be the rate at which a container can be deployed on a VM and $1/\mu$ be the mean value of container lifetime (both exponentially distributed). So, the total service rate for each VM is the product of the number of running containers by μ . Assume β^+ and β^- are the rates at which the MSP can obtain and release a VM, respectively.

CSM asks for a new VM from backend cloud (i.e., macro-service infrastructure) when explicitly ordered by the MSP user or when the utilization of the host group is equal or greater than a predefined value. For state (i, j, k) , utilization (u) is defined as follows,

$$u = \frac{i + j}{k \times M} \quad (1)$$

in which M is the maximum number of containers that can be run on a single VM.

The value of u indicates the ratio of active containers to the total available containers at each state. In this scenario, if the utilization drops lower than a predefined threshold, the CSM will release one VM to optimize the cost. A VM can be released if there are no running containers on it, so the VM should be fully decommissioned in advance. Also, the CSM holds a minimum number of VMs in the Host Group regardless of utilization, in order to maintain the availability of the service (s). The user may also set another value for its application(s) (S) indicating that

the MSP can not request more than S VMs from macroservice infrastructure on behalf of the user. Thus, the application scales up at most to S VMs in case of high traffic and scales down to s VMs in times of low utilization. We set the global queue size (L_q) to the total number of containers that it can accommodate at its full capacity (i.e., $L_q = S \times M$). Note that the request will be blocked if the user reached its capacity, regardless of the Global Queue state.

State $(0, 0, s)$ indicates that there are no requests in the queue, no running container, and the Host Group consists of s VMs which is the minimum number of VMs that the user maintains in its Host Group. Consider an arbitrary state such as (i, j, k) , in which five transitions might happen:

- 1) Upon the arrival of a new request, the system moves to state $(i + 1, j, k)$ with a rate of λ if the user still has the capacity (i.e., $i + j < S \times M$), otherwise the request will be blocked, and the system stays in the current state.
- 2) The CSM instantiates a container with rate ϕ for the request in the head of Global Queue and moves to $(i - 1, j + 1, k)$.
- 3) The lifetime of a container is exponentially distributed and ends with a rate of $j\mu$ and the system moves to $(i, j - 1, k)$.
- 4) If the utilization goes higher than the threshold, MSP requests a new VM, and the system moves to state $(i, j, k + 1)$ with a rate of β^+ .
- 5) Or the utilization drops below a certain threshold, MSP decommissions a VM, and the system releases the idle VM, so it moves to $(i, j, k - 1)$ with rate β^- .

Note that CSM (depicted in Fig. 3) is only for one user (or one application in another sense). In this work, we assume homogeneous users so that we only need to solve one CSM regardless of the number of users at MSP. Suppose that $\pi_{(i,j,k)}$ is the steady-state probability for the CSM (Fig. 3) to be in the state (i, j, k) , which is calculated the same way as in [14]. So, the blocking probability in CSM can be calculated as follows:

$$bp_q = \sum \pi_{(i,j,k)} \quad \text{if } i + j = L_q \quad (2)$$

We are also interested in two probabilities by which the MSP requests (p_{req}) or releases (p_{rel}) a VM.

$$p_{req} = \sum \pi_{(i,j,k)} \quad \text{if } u \geq \text{high-util} \ \& \ k < S \quad (3)$$

$$p_{rel} = \sum \pi_{(i,j,k)} \quad \text{if } u \leq \text{low-util} \ \& \ k > s \quad (4)$$

Using these probabilities, the rate by which microservice platform requests (λ_c) or releases (η_c) a VM can be calculated.

$$\lambda_c = \lambda \times p_{req} \quad (5)$$

$$\eta_c = \mu \times p_{rel} \quad (6)$$

In order to calculate the mean waiting time in queue, we first calculate the number of requests in the queue as

$$\bar{q} = \sum_{i=0}^{L_q} i \cdot \pi_{(i,j,k)} \quad (7)$$

Applying Little's law [32], the mean waiting time in the global queue is given by:

$$\overline{wt}_q = \frac{\bar{q}}{\lambda(1 - bp_q)} \quad (8)$$

Instantiation time for containers ($1/\phi$) will be added to \overline{wt}_q to obtain the total delay in the microservice platform.

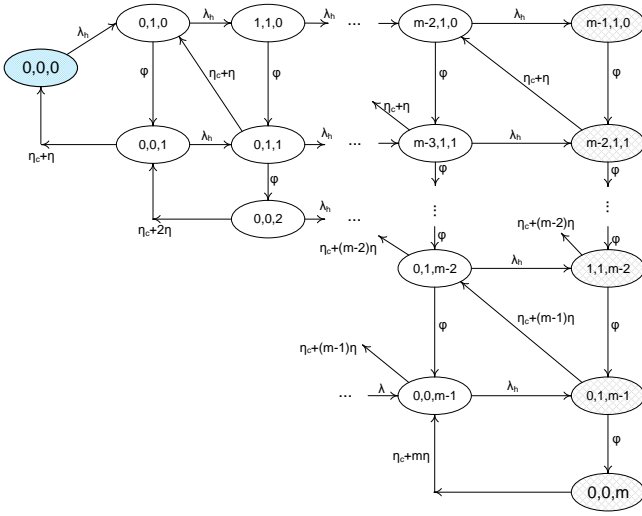

Fig. 6. Virtual Machine Provisioning Sub-Model for a PM in the pool (VMSM).

VMs that can be deployed on a PM. Also, the hypervisor can only deploy one VM at a time to the PM, so the value of j is 0 when the instantiation unit is idle and will be 1 when it is deploying a VM. Let δ be the rate at which a VM can be deployed on a PM and η be the service rate of each VM. So, the total service rate for each PM is the product of the number of running VMs by η . Note that in VMSM, a VM may get released due to two events; first, the service time of VM is finished (the rate is η) and second if the microservice platform specifically asks for termination of that VM (with a rate of η_c , see Fig. 6).

State $(0, 0, 0)$ indicates that the PM is empty, and there is no request either in the queue or in the instantiation unit. Upon the arrival of a request, the model transits to state $(0, 1, 0)$. The arrival rate to each PM is given by:

$$\lambda_h = \frac{\lambda_a(1 - BP_q)}{N} \quad (14)$$

in which N is the number of PMs in the pool. Note that BP_q , used in (9), is obtained from PMSM. The state transition in VMSM can occur due to request arrival, VM instantiation or service completion. From state $(0, 1, 0)$, the system can move to state $(1, 1, 0)$ with rate λ_h . From $(1, 1, 0)$, the system can transit to $(0, 1, 1)$ with rate δ (i.e., instantiation rate) or upon arriving a request moves to state $(2, 1, 0)$. From $(0, 1, 1)$, system can move to $(0, 0, 2)$ with rate δ , transits to $(0, 1, 0)$ with rate $\eta + \eta_c$ (i.e., service completion or an explicit request from microservice platform), or again upon arriving a request, system can move to state $(1, 1, 1)$ with rate λ_h .

Suppose that $\pi_{(i,j,k)}$ is the steady-state probability for the PM model (Fig. 6) to be in the state (i, j, k) . Using steady-state probabilities, we can obtain the probability that at least one PM in the pool can accept the request for provisioning. At first, we need to compute the probability that a PM cannot admit a request for provisioning (P_{na}):

$$P_{na} = \sum \pi_{(i,j,k)} \quad \text{if } i + j + k = m \quad (15)$$

Therefore, the probability of successful provisioning (P_s) in the pool can be obtained as

$$P_s = 1 - (P_{na})^N \quad (16)$$

Note that P_s is used as an input parameter in the PMSM (Fig. 4).

From VMSM, we can also obtain the mean waiting time at PM's queue (third delay: $\overline{PM_{wt}}$) and mean provisioning time (fourth delay: \overline{pt}) by using the same approach as the one that led to Eq. (12). As a result, the total delay in macroservice infrastructure before having VM ready for servic is given by:

$$\overline{td} = \overline{wt_Q} + \overline{lut} + \overline{PM_{wt}} + \overline{pt} \quad (17)$$

Using Eq. 17 we can calculate α and β rates that are input parameters for the container sub-model (CSM). We assume that, without loss of generality, the amount of time that takes to obtain a VM is equal to the time that is needed to release the VM.

$$\alpha = \beta = 1/\overline{td} \quad (18)$$

4.3 Interaction among Sub-Models

The interactions among sub-models are depicted in Fig. 7 and also described in Table 4. From container sub-model (CSM), the request rate for new VMs (i.e., λ_c), as well as release rate of VMs (i.e., η_c), can be calculated (see Eq. 5); these are used as inputs to PM assigning sub-model (PMSM) and VM provisioning sub-model (VMSM), respectively. From the macroservice model, which includes both PMSM and VMSMs, the amount of time that CSM can obtain (i.e., $1/\alpha$) or release (i.e., $1/\beta$) a VM will be calculated; these two are input parameters for CSM. The VMSMs compute the steady-state success probability (P_s that at least a PM in the pool can accept the request. This success probability is used as input parameters to the PMSM. The PMSM computes the blocking probability, BP_q , which is the input parameter to the VM provisioning sub-model. Since α and β are computed using both PMSM and VMSM, we show them as the outputs of the MSI in Fig. 7 as well as Table 4.

TABLE 4
Sub-models and their inputs/outputs.

Model or Sub-model	Input(s)	Output(s)
CSM	α, β	λ_c, η_c
PMSM	λ_c, P_s	BP_q
VMSM	η_c, BP_q	P_s

As can be seen, there is an inter-dependency among sub-models. This cyclic dependency is resolved via the fixed-point iterative method [30] using a modified version of the successive substitution approach.

For numerical experiments, the successive substitution method (Algorithm 1) is continued until the difference between the previous and current value of blocking probability in the global queues for both CSM and PMSM (i.e., BP_q and bp_q) are less than 10^{-6} as the max_err . The integrated model usually converges to the solution in less than 15 iterations for each while-loop. When Algorithm 1 converges, then performance metrics will be calculated. A *null* return value has been used to signal the algorithm has not converged and thus needs a better initial value.

It can be shown that fixed-point variable BP_q can be expressed as a function of P_s , and variable bp_{q0} can be expressed as a

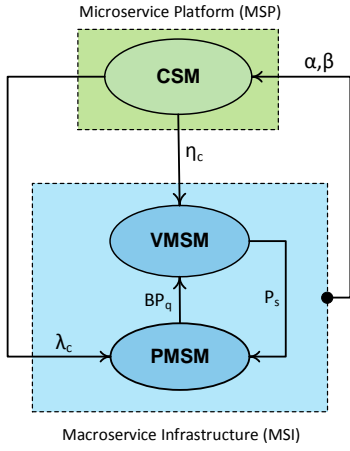

Fig. 7. Interaction diagram among layers; microservice platforms have been modelled with one sub-model while macroservice infrastructure has been modelled with two sub-models.

function of α and β . For this reason, before starting the fixed-point iteration, we guess an initial value for P_s , and we check the values of BP_q in successive iterations to determine the condition for convergence in the inner loop. The same procedure will be followed for the external *while* loop, and finally, the fixed-point iteration will converge. Fixed-point iteration starts by calling the function $CSM(\cdot)$ to obtain the steady solution of the container sub-model. The output of $CSM(\cdot)$ is the steady-state queue size (bp_{q0}) that the job will be blocked in the microservice platform. Function $PMSM(\cdot)$ uses this updated bp_{q0} as an input parameter and solves the PMSM sub-model for the steady-state solution. Then, the inner loop will iterate until we get a steady-state solution for the macroservice model. Afterwards, α and β will be calculated using Eq. 20. The steady-state value for queue size at the microservice platform bp_{q1} is obtained and compared to the previous value. If the difference is less than the threshold, then the algorithm converges, and the final steady-state values for BP_{q0} and bp_{q0} will be calculated. The proof of the existence of a solution, for this method in general, has been detailed in [35].

4.4 Scalability and flexibility of the integrated model

Both macroservice infrastructure and microservice platform may scale up or down in terms of global queue sizes, number of PMs in the pool, number of VMs in user quota and the degree of virtualization (in both VM and container level) which are referred as *design parameters*. Table 5 shows the relationship between the number of states in each sub-model and their associated design parameters.

As can be seen from Table 5, the number of states in each sub-model has a linear or polynomial dependency to design parameters that guarantees the scalability of the integrated model. Note that VMSMs are identical for all PMs in the pool. Therefore, we only need to solve one VMSM regardless of the number of PMs in the macroservice infrastructure.

5 NUMERICAL VALIDATION

In this section, we first describe our experimental setup on the Amazon EC2 cloud; then, we discuss the results and insights that

Algorithm 1: Successive Substitution Method.

```

input : Initial success probability in the pool:  $P_s$ 
input : Initial rate for requesting or releasing a VM:  $\alpha, \beta$ 
output : Blocking probability in Global Queues:  $BP_q, bp_q$ 
1 counter_a  $\leftarrow$  0; max_a  $\leftarrow$  10; diff_a  $\leftarrow$  1;
2 counter_b  $\leftarrow$  0; max_b  $\leftarrow$  10; diff_b  $\leftarrow$  1;
3  $bp_{q0} \leftarrow CSM(\alpha, \beta)$ ; (Eq. 2)
4 while diff_a  $\geq$  max_err do
5   counter_a  $\leftarrow$  counter_a + 1;
6    $BP_{q0} \leftarrow PMSM(bp_{q0}, P_s)$ ; (Eq. 9)
7   while diff_b  $\geq$  max_err do
8     counter_b  $\leftarrow$  counter_b + 1;
9      $P_s \leftarrow VMSM(BP_{q0})$ ;
10     $BP_{q1} \leftarrow PMSM(bp_{q0}, P_s)$ ;
11    diff_b  $\leftarrow |BP_{q1} - BP_{q0}|$ ;
12     $BP_{q0} \leftarrow BP_{q1}$ ;
13    // if maximum try is reached
14    if counter_b = max_b then
15      return null;
16   $[\alpha, \beta] \leftarrow calculate\_alpha\_beta()$ ; (Eq. 18)
17   $bp_{q1} \leftarrow CSM(\alpha, \beta)$ ;
18  diff_a  $\leftarrow |bp_{q1} - bp_{q0}|$ ;
19   $bp_{q0} \leftarrow bp_{q1}$ ;
20  if counter_a = max_a then
21    return null;
22 return [ $BP_{q0}, bp_{q0}$ ];

```

TABLE 5

Relationship between the size of sub-models and design parameters.

Sub-Model	Design Parameters	No. of States: $f(i)$
CSM	s, S, M	$f(s, S, M) = MS^2 - sMS$
PMSM	L_Q	$f(L_Q) = 2L_Q + 1$
VMSM	m	$f(m) = 3,$ if $m=1$ $f(m) = 6,$ if $m=2$ $f(m) = 2f(m-1) - f(m-2) + 1,$ if $m > 2$

we obtained from the real implementation and deployment of our microservice platform. Next, the analytical model will be tuned and validated against experimental results. Finally, we leverage the analytical model to study and investigate the performance of the microservice platform at a large scale for various configuration and parameter settings.

5.1 Experimental Setup

Here, we present our microservice platform and discuss experiments that we have performed on this platform. For experiments, we couldn't use available third-party platforms such as Docker Cloud or Nirmata as we needed full control of the platform for monitoring, parameter setting, and performance measurement. As a result, we have created a microservice platform from scratch based on the conceptual architecture presented in Fig. 1. We employed Docker Swarm as the cluster management system, Docker as the container engine and Amazon EC2 as the backend public cloud. We developed the front-end in Java for the microservice platform that interacts with the cluster management system (i.e., Swarm) through REST APIs. The microservice platform leverages three initial VMs with two configured in *worker* mode and another one in *master* mode to manage the Docker Swarm cluster. All VMs are of type `m3.medium` (1 virtual CPU with 3.5 GB memory). In our deployment, we have used *Consul* as the discovery service that has been installed on the Swarm Manager VM.

For the containers, we have used Ubuntu 16.04 image available on Docker Hub. Each running container was restricted to use only 512MB memory, thus making the capacity of a VM to be seven containers. The Swarm manager strategy for distributing containers on worker nodes was *binpack*. The advantage of this strategy is that fewer VMs can be used since Swarm will attempt to put as many containers as possible on the current VMs before using another VM. Table 6 presents the input values for the experiments.

TABLE 6
Range of parameters for experiments.

Parameter	Value(s)	Unit
Arrival rate	20 . . 40	req/min
Queue size	10	container
VM capacity	7	container
Container lifetime	2	minute
Desired utilization	70% . . 90%	N/A
Initial cluster size	2	VM
Max cluster size	10	VM

In order to control the experiment’s costs, we have limited the cluster size to a maximum of 10 running VMs for the application, which gives us a maximum capacity of 70 running containers. For the same reason, we set the container lifetime as 2 minutes in the experiment. Under this configuration, our experiment takes up to 640 minutes. The results of our experiment are presented in Fig. 8. Note that the X axis in Fig. 8 is experiment time in which we report the average values of performance indicators in every single minute; hereafter, we call each minute of the experiments an *iteration*. As can be seen in Fig 8, the result of the experiment from iteration 60 to 580 has been ignored to present the interesting events and moments during the experiment more clearly on graphs¹.

In the experiment, the lower and upper utilization thresholds are set to 70% and 90%, respectively (shaded area in the fourth plot of the full version of Fig. 8 linked in the footnote that shows the areas where the cluster is underloaded or overloaded). The arrival rate has a Poisson distribution with a mean value of 20 to 40 requests per minute, shown in the second plot of Fig. 8 with a blue line. In the first plot, the red line shows the number of running VMs and the blue line enumerates the number of running containers.

5.2 Experimental Results

An interesting observation here is the behaviour of the system at the beginning of the experiment. The capacity of the cluster is 2 VMs that can support up to 14 containers. The experiment starts with 20 requests per minute, for which the current capacity is not enough. Therefore, as can be seen from iteration 0 to 20, the number of VMs and containers increases linearly (first plot in Fig. 8). This is due to the high utilization of the cluster (fourth plot in the full version of Fig. 8 linked in the footnote) that triggers the autonomic manager to scale up the cluster. At the same time, in the second plot in Fig. 8, the response time is declining after a sudden jump (i.e., up to approximately 140 s) and also we see many rejected requests due to *full queue* (indicated by legend “req. rej. (fq)”) during the first 20 iteration of the experiment.

1. Another version of Figure 8 including the whole experiment and utilization plot can be found [here](#).

In the third plot of Fig. 8, we show the throughput of the system by measuring the number of successful containers that have been provisioned during each iteration in the experiment. Also, for each iteration, we show the percentage of containers that have been provisioned without queuing by yellow colour. In our experiment, if a request gets service in less than 10 ms, we categorize it as *immediate service*, which indicates that the request did not experience any queuing in the system. As can be seen, during the first 20 iterations of the experiment, almost all of the requests for containers have experienced a delay due to queuing.

Around iteration 20, the system reaches the capacity that can handle the workload so we can see that response time drops to less than a second (approximately 450 ms), there is no blocking request due to full queue anymore, and utilization is back to the normal area. Also, we can see that after iteration 20 most of the request gets immediate service so that containers are being provisioned for customers without any delay (look at yellow bars in the third plot that are indicating this fact). We let the experiment continue from iteration 60 to 580 while increasing the workload smoothly. During this time, the system adapts to the changing workload accordingly and maintains the performance indicators at desired ranges.

However, after iteration 580, we can see that (first plot in Fig. 8) the cluster is about its capacity (i.e., 10 VMs and 70 containers). As a result, we notice some request rejections due to *no capacity* in the system (indicated with a legend of “req. rej. (nc)” in the second plot). When the workload gets beyond the 30 requests per second (i.e. after iteration 600), the cluster gets its full capacity, which leads to continued rejection of requests due to lack of capacity. Despite request rejection and running at full capacity, performance indicators (i.e., response time and immediate service) are desirable as opposed to what we have witnessed at the beginning of the experiment. In the last 20 iterations of the experiment since the system is running at capacity, the autonomic manager drops the new requests immediately so that the queue gets cleared very fast; therefore, when capacity becomes available, the new request will get into the service immediately which results in very good response time as well. However, at the beginning of the experiment, i.e. first 20 iterations, the autonomic manager knows that there is extra capacity, so it lets the requests to be queued till the new VMs get provisioned; VM provisioning takes around 110 seconds on average which contributes to the long response times at the beginning of the experiment.

5.3 Validation of the Analytical Model

In this section, we validate the analytical model with the results of the experiments presented in section 5.2. We use the same parameters, outlined in Table 6, for both experiments and numerical analysis. The analytical model has been implemented and solved in Python using NumPy, SciPy and Sympy libraries [36]. Table 7 shows the comparison between the results from the analytical model and experiment. As can be seen, both the analytical model and experimental results are well in tune with an error of less than 10%. Note that in the experiment, we consider requests that get into service less than 10 ms as immediate service; This value has been approximated based on our experience with SAVI [33] cloud in processing requests when there is no queuing. It might be different in other cloud data centers. It should be noted that 10 ms is the request processing and not the resource provisioning. Changing this value will directly impact the resulted number

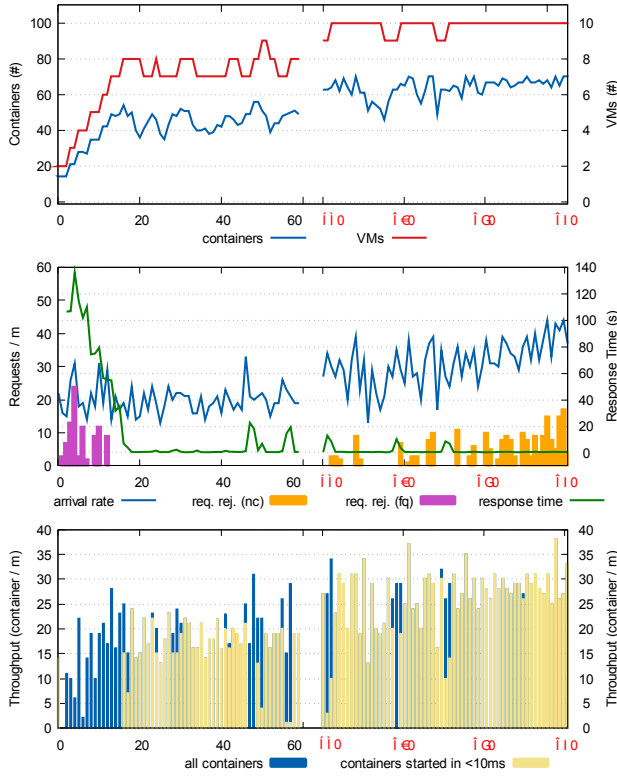

Fig. 8. Experimental results; see Table 6 for parameter settings.

of requests with immediate service in our calculation in both analytical and experimental evaluation.

TABLE 7

Corresponding results from the analytical model and experiment.

Parameter	Analytical Model	Experiment
Response Time	2.89	3.211
Utilization	81.4%	85.3%
Mean No of VMs	7.12	7.61
Mean No of Containers	39.8	43.8
Immediate Service Prob.	0.7415	0.782

5.4 What-if Analysis and Capacity Planning

The presented performance model executed within a couple of seconds on a Macbook Pro with 16 GB of memory and 2.5 GHz quad-core Core-i7 CPU. Thanks to this minimal cost and runtime associated with the analytical performance model, we leverage it to study interesting scenarios on a large scale with different configurations and parameter settings to shed some light on MSP provisioning performance. More specifically, in this section, we show how under different configurations and parameter settings, we obtain three important performance metrics, namely, rejection probability of requests, total response delay and the probability of immediate service in both MSP and MSI. Note that due to space limitations, we only present a subset of results in this section. Table 8 presents the range of individual parameter values that we set for numerical analysis.

TABLE 8
Range of parameters for numerical experiment.

Microservice Platform (MSP)		
Parameter	Range	Unit
No. of users in MSP	20	N/A
Arrival rate per user	0.4 . . 2	request/min
User's quota	16 . . 28	container
No. of containers on each VM	4	N/A
Container provisioning time	300 . . 1500*	millisecond
Container lifetime	4 . . 20	minute
Normal Host Group utilization	40% . . 80%	N/A
Minimum Host Group size	2	VM
Macroservice Infrastructure (MSI)		
Parameter	Range	Unit
Arrival rate	60	request/hour
VM lifetime	1 . . 5	day
No. of PMs in the pool	150	PM
No. of VMs on each PM	4	VM
Mean look-up rate in the pool	60	search/min
VM provisioning time	1 . . 3*	minute
Size of global queue	100	requests
*These values have been obtained from experiments.		

5.4.1 First Scenario: Fixed Arrival Rate

In the first scenario, we investigate the effects of container lifetime and the users' quota on rejection probability and total delay in both MSP and MSI. For the MSI, we set 2 days as the mean VM lifetime and assume 150 PMs in the servers' pool, each of which can run up to 4 VMs. In the first scenario, the results of which are shown in Fig. 9, as can be noticed, both container lifetime and user quota have a significant impact on rejection probabilities. The impact of quota and lifetime is almost the same in MSP (Fig 9(a)) as well as MSI. Also, in order to harness the rejection probability under 10%, at least 4 VMs should be assigned to the user, and the container lifetime should be less than 12 minutes in the MSP. However, as can be seen from Fig. 9(b), if the goal is to maintain less than 10% rejection in MSI, the container lifetime should be less than 12 minutes, and at least 5 VMs should be assigned to the user's host group. From Fig. 9(b), we can identify a very narrow area in which the backend cloud operates in a stable regime (i.e., the narrow dark blue rectangle) and will enter to unstable state with a little fluctuation either in containers' lifetimes or users' quota.

We also measure the delays in both micro and macro layers. Note that the delay in microservice level is the aggregate waiting and processing time before having the containers ready for service; in the macro layer, it is all imposed delays on request before getting the VM up and ready to be used. Fig. 10 indicates that the trend of delays is in tune with rejection probabilities. From Fig. 10(a), it can be observed that if there is no need for a new VM, the request will be processed usually in less than a second, but if there is no VM that can accommodate the new container the delay might increase up to 27 seconds. Fig 10(b) shows that, if the load is low, the macroservice infrastructure can provision a VM in 108 seconds on average (i.e., only processing time) but as traffic intensity gets high it might take up to 170 seconds on average to get a VM.

5.4.2 Second Scenario: Fixed User Quota

For the second scenario, we fixed the user quota at 16 containers and then studied the rejection probabilities and total delays by

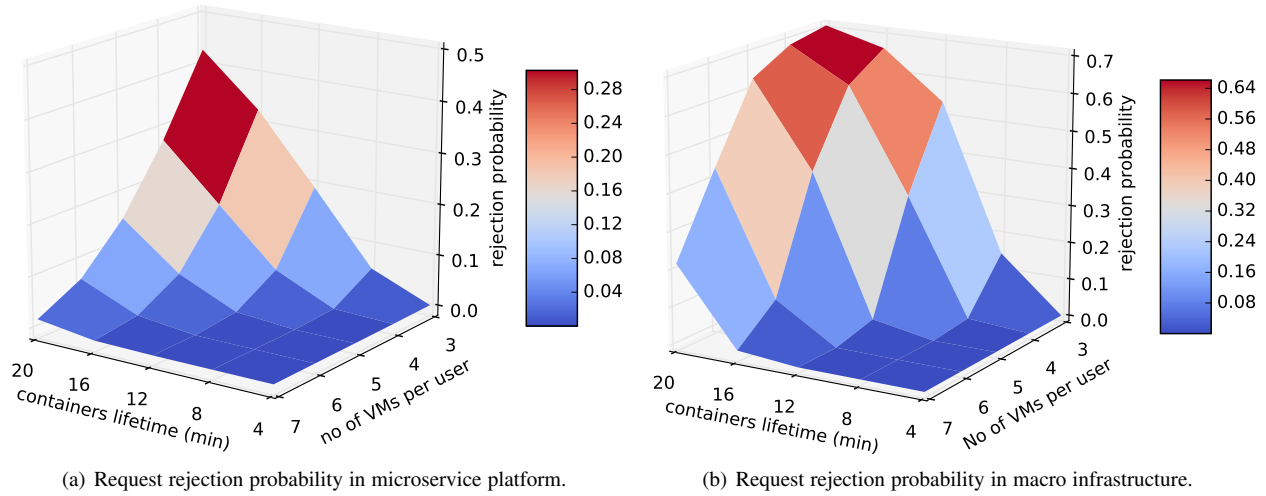

Fig. 9. First scenario: rejection probability w.r.t containers' lifetime and the user's quota.

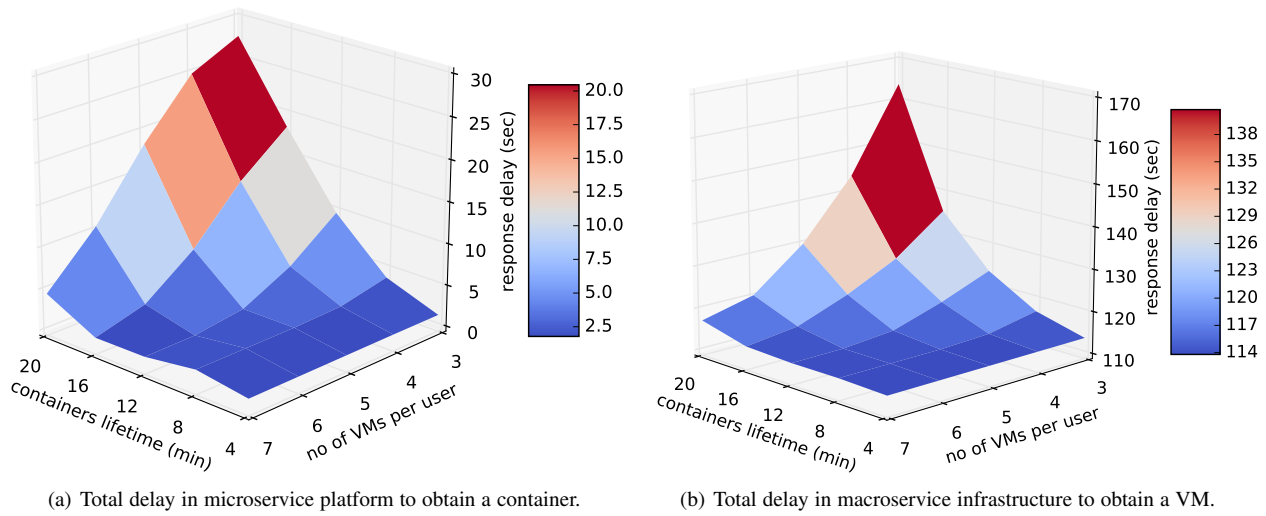

Fig. 10. First scenario: total response delays w.r.t containers' lifetime and the user's quota;

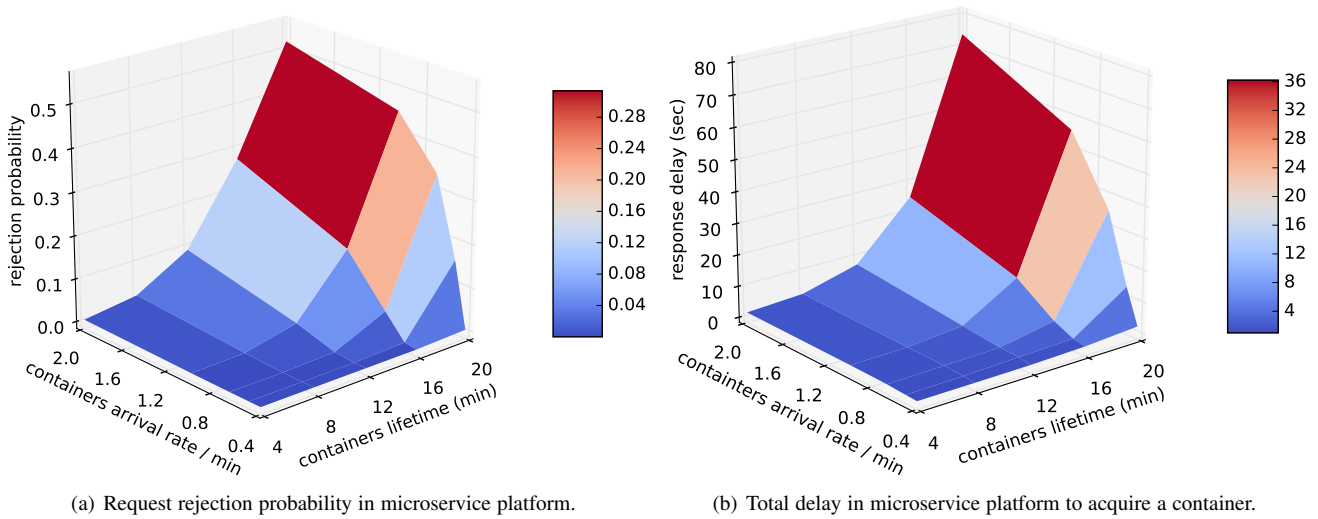

Fig. 11. Second scenario: rejection probability and response delay w.r.t containers' lifetime and the arrival rate.

varying the container lifetime and arrival rate of requests for containers. This can help visualize the trade-off between lower provisioning time and higher operational cost with having longer container lifetime. For the macroservice infrastructure, we set 2 days as the mean VM lifetime and again assume 150 PMs in the pool. In this scenario, we let each PM to run 4 VMs. From Fig. 11(a), it can be noticed that if the container lifetime increases linearly, the rejection probability increases exponentially while with increasing arrival rate, it increases sub-linearly. Therefore, if the user does not ask for more than 2 containers per minute and container lifetime stay below 12 minutes, the rejection probability would be less than 10%.

From the diagram in Fig. 11(b), we can see that MSP imposes a long delay on requests in worst cases compared to the first experiment (i.e., Fig. 10(a)). For example, in the microservice platform, when containers' lifetime and arrival rate are high (i.e., 20 minutes and 2 containers per minute respectively), the delay may bump up to 80 seconds. One potential solution for addressing this long delay is to permit MSP to ask for more than one VM at a time (i.e., making batch requests). We also characterize the probability of immediate service for both scenarios at both MSP and MSI. This metric shows how many of requests get into the service without any delay (i.e., queuing delay). As can be seen in Fig. 12, the trend of immediate services probabilities are inverse to the trend of their corresponding rejection probabilities (i.e., compare Fig. 12(a) with 9(a) and Fig. 12(b) with 11(a)). However, it should be noted that these two probabilities are not truly complementing as there are some requests that neither get rejected, nor immediate service rather get into services after some queuing. Note that in the second scenario, we don't present the results for MSI due to the page limit.

6 RELATED WORK

Performance analysis of cloud computing has attracted considerable research attention, although most of the works considered hypervisor-based virtualization in which VMs are the sole way of providing an isolated environment for the users [37], [38]. However, recently, container-based virtualization has been getting momentum due to its advantages over VMs for providing microservices.

Performance analysis of IaaS clouds has been investigated extensively under various configurations and use cases. In [14], [39], [40], [41], monolithic analytical performance models have been proposed and evaluated. An analytical model based on Markov chains to predict the number of cloud instances or VMs needed to satisfy a given SLA performance requirement such as response time, throughput, or request loss probability has been proposed in [42]. In [28], [43], the authors proposed a general analytical model for end-to-end performance analysis of a cloud service. They illustrated their approach using IaaS cloud with three pools of servers: hot, warm and cold, using service availability and provisioning response delays as the key QoS metrics. The proposed approach reduces the complexity of performance analysis of cloud centers by dividing the overall model into sub-models and then obtaining the overall solution by iteration over individual sub-model solutions.

The authors in [44] used a Fluid Petri Net model to analyze the characteristics of a microservice platform. Research conducted in [45] analyzes large-scale microservice platforms using simulated traces. Our work in this paper is based on [8]. However, our

previous work only models the microservice layer and treat the back-end IaaS as a black box by assuming a stable performance by the back-end cloud throughout time. But, our experiments with various cloud infrastructures revealed that the throughput and efficiency of the back-end cloud infrastructure vary event during short periods of time. Thus, in this work, we analyze all three levels of PMs, VMs, and container with three sub-models which renders this work as an accurate model for microservice platforms.

Performance analysis of cloud services considering containers as a virtualization option is in its infancy. Much of the works have been focused on the comparison between the implementation of various applications deployed either as VMs or containers. In [24], authors made a performance comparison, including a front end application server hosting Joomla PHP application and backend server hosting PostgreSQL database for storing and retrieving data for the Joomla application. They showed that containers have outperformed VMs in terms of performance and scalability. Container deployment process 5x more requests compared to VM deployment and also containers outperformed VMs by 22x in terms of scalability. This work shows promising performance when using containers instead of VMs for service delivery to end-users.

Other works have focused on different aspects of microservice architecture. The study performed in [46] performs a cost comparison between running the same service in the cloud using monolithic, microservice, and serverless architectures. The serverless architecture in this study uses the microservices developed, but managed and operated by the cloud provider. They found that microservices are a very cost-effective way of deploying workloads to the cloud. Heorhiadi et al. [47] performed systematic resilience testing of microservices. Inagaki et al. [48] studied the scalability of different container management operations for docker and identify scalability bottlenecks bottlenecks for this platform. Ueda et al. [49] performed a study to understand the characteristics of different microservice workloads as means to design an infrastructure that is optimized for microservices.

The authors in [50], [51] performed a more comprehensive study on performance evaluation of containers under different deployments. They used various benchmarks to study the performance of native deployment, VM deployment, native Docker and VM Docker. In native deployment, the application is installed in a native OS; in VM deployment, the application is installed in a vSphere VM; in native Docker, the application is installed in a container that is being run on a native OS; and finally, a Docker container including the application is deployed on a vSphere VM that itself is deployed on a native OS. Redis has been used as the backend datastore in this experiment. All in all, they showed that in addition to the well-known security, isolation, and manageability advantages of virtualization, running an application in a Docker container in a vSphere VM adds very little performance overhead compared to running the application in a Docker container on a native OS. Furthermore, they found that a container in a VM delivers near-native performance for Redis and most of the micro-benchmark tests.

These studies reveal a promising future for using both virtualization techniques in order to deliver secure, scalable and high performant services to the end-user [52], [53]. The recent popularity of microservice platforms such as Docker Tutum [9], Nirmata [11] and Google Kubernetes [10] are attributed to such advantages mentioned above. However, to the best of our knowledge, there is

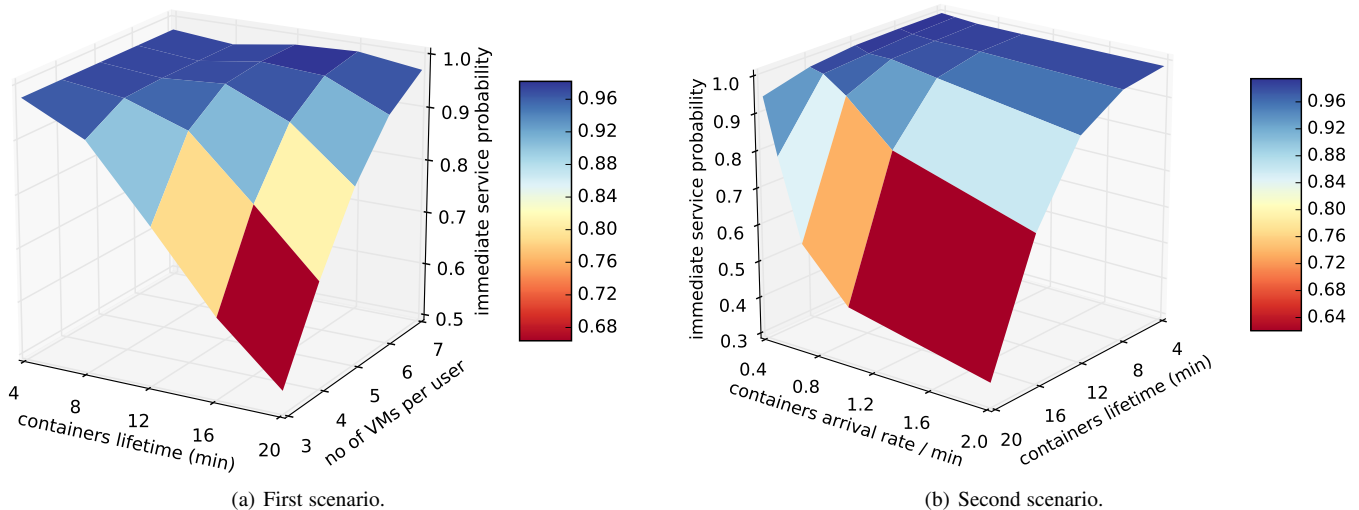

Fig. 12. Probability of immediate service; probability by which requests get into service without any queuing.

no comprehensive performance model that incorporates the details of the microservice platform and macroservice infrastructure. In this work, we studied the performance of PaaS and IaaS, collaborating with each other to leverage both virtualization techniques for providing fine-grained, secure, scalable and performant services.

7 CONCLUSIONS

In this paper, we presented a performance model suitable for analyzing the provisioning quality of microservice platforms while incorporating the details of servicing in the backend IaaS cloud using interacting stochastic models. We have developed a comprehensive analytical model that captures important aspects of the system including microservices management, resource assigning process, and virtual machine provisioning. The performance model can assist cloud micro/macro service providers to maintain their SLA in a systematic manner. In other words, the proposed and evaluated performance model in this paper provides a systematic approach to study the elasticity of microservice platforms by evaluating the provisioning performance at both the microservice platform and the back-end cloud.

We have also implemented a microservice platform from scratch to estimate related parameters to be used for calibration of the analytical model. After introducing the measurements provided by the real implementation into the performance model, we carried out an extensive numerical analysis to study the effects of various parameters such as the request arrival rate for containers, container lifetime, VM lifetime, virtualization degree, and the size of the users' application on the request rejection probability, probability of immediate service and response time. We showed that using the performance model, we can characterize the behaviour of the system at scale for given configurations and therefore facilitate the capacity planning and SLA analysis by both micro and macro service providers.

ACKNOWLEDGMENTS

We would like to thank Dr. Murray Woodside for his valuable technical comments and inputs. This research was supported by the Natural Sciences and Engineering Council of Canada (NSERC).

REFERENCES

- [1] A. Khan, "Key characteristics of a container orchestration platform to enable a modern application," *IEEE Cloud Computing*, vol. 4, no. 5, pp. 42–48, September 2017.
- [2] S. Soltesz, H. Pötzl, M. E. Fiuczynski, A. Bavier, and L. Peterson, "Container-based operating system virtualization: a scalable, high-performance alternative to hypervisors," in *ACM SIGOPS Operating Systems Review*, vol. 41, no. 3. ACM, 2007, pp. 275–287.
- [3] D. Bernstein, "Containers and cloud: From lxc to docker to kubernetes," *IEEE Cloud Computing*, vol. 1, no. 3, pp. 81–84, 2014.
- [4] J. Beda. (2015, 05) Containers at scale: the Google Cloud Platform and Beyond. [Online]. Available: <https://speakerdeck.com/jbeda/containers-at-scale>
- [5] A. Celesti, D. Mulhari, M. Fazio, M. Villari, and A. Puliafito, "Exploring container virtualization in IoT clouds," in *IEEE International Conference on Smart Computing*. IEEE, 2016, pp. 1–6.
- [6] B. Burns and D. Oppenheimer, "Design patterns for container-based distributed systems," in *HotCloud*, 2016.
- [7] D. Merkel, "Docker: lightweight linux containers for consistent development and deployment," *Linux Journal*, vol. 2014, no. 239, p. 2, 2014.
- [8] H. Khazaei, C. Barna, N. Beigi-Mohammadi, and M. Litoiu, "Efficiency analysis of provisioning microservices," in *IEEE International Conference on Cloud Computing Technology and Science (CloudCom)*. IEEE, 2016, pp. 261–268.
- [9] Docker Cloud. (2017, 3) The Docker Platform for Dev and Ops. [Online]. Available: <https://cloud.docker.com>
- [10] Google, Inc. (2018, 10) Manage a cluster of Linux containers as a single system to accelerate Dev and simplify Ops. [Online]. Available: <http://kubernetes.io/>
- [11] Nirmata, Inc. (2017, 3) Microservices Operations and Management. [Online]. Available: <http://nirmata.com>
- [12] hook.io, Inc. (2018, 9) Microservices and Webhook Hosting. [Online]. Available: <http://hook.io>
- [13] vamp.io, Inc. (2018, 9) Automation and Controls for Enterprise Devops. [Online]. Available: <http://vamp.io>
- [14] H. Khazaei, J. Mišić, and V. B. Mišić, "Performance analysis of cloud computing centers using $M/G/m/m + r$ queueing systems," *tpds*, vol. 23, no. 5, p. 1, 2012.
- [15] F. Longo, R. Ghosh, V. K. Naik, and K. S. Trivedi, "A scalable availability model for infrastructure-as-a-service cloud," *Dependable Systems and Networks, International Conference on*, pp. 335–346, June 2011.
- [16] VMware, Inc. (2016, 6) VMware vSphere Hypervisor. Website. [Online]. Available: <http://www.vmware.com/products/vsphere-hypervisor>
- [17] KVM. (2016, 6) Kernel-based Virtual Machine. [Online]. Available: http://www.linux-kvm.org/page/Main_Page
- [18] Citrix Systems, Inc. (2016, 6) Xen Hypervisor. Website. [Online]. Available: <http://www.xen.org>
- [19] Microsoft, Inc. (2016, 6) Windows Server Virtualization. [Online]. Available: <http://www.microsoft.com/en-ca/server-cloud/solutions/virtualization.aspx>

- [20] Rackspace Cloud Computing. (2016, 6) Openstack, an open source software for creating private and public clouds. [Online]. Available: <https://www.openstack.org>
- [21] Apache Foundation. (2016, 6) Apache CloudStack. [Online]. Available: <https://cloudstack.apache.org/>
- [22] Eucalyptus Systems, Inc. (2016, 6) HPE Helion Eucalyptus. [Online]. Available: <http://www8.hp.com/us/en/cloud/helion-eucalyptus-overview.html>
- [23] W. Felter, A. Ferreira, R. Rajamony, and J. Rubio, "An updated performance comparison of virtual machines and linux containers," *technology*, vol. 28, p. 32, 2014.
- [24] A. M. Joy, "Performance comparison between linux containers and virtual machines," in *Computer Engineering and Applications (ICACEA), 2015 International Conference on Advances in*. IEEE, 2015, pp. 342–346.
- [25] S. Graber *et al.* (2016, 6) LXC-Linux containers. [Online]. Available: <https://linuxcontainers.org>
- [26] V. Marmol *et al.* (2016, 6) Let me contain that for you. [Online]. Available: <https://github.com/google/lmctfy/blob/master/README.md>
- [27] Warden, Inc. (2016, 6) Cloud Foundry Warden documentation. [Online]. Available: <http://docs.cloudfoundry.org/concepts/architecture/warden.html>
- [28] H. Khazaee, J. Mišić, and V. B. Mišić, "A fine-grained performance model of cloud computing centers," *IEEE Transactions on Parallel and Distributed Systems*, vol. 24, no. 11, pp. 2138–2147, November 2013.
- [29] K. S. Trivedi, *Probability and Statistics with Reliability, Queuing and Computer Science Applications*, 2nd ed. Wiley, July 2001.
- [30] V. Mainkar and K. S. Trivedi, "Sufficient conditions for existence of a fixed point in stochastic reward net-based iterative models," *Software Engineering, IEEE Transactions on*, vol. 22, no. 9, pp. 640–653, September 1996.
- [31] G. Grimmett and D. Stirzaker, *Probability and Random Processes*, 3rd ed. Oxford University Press, Jul 2010.
- [32] L. Kleinrock, *Queueing Systems, Volume 1, Theory*. Wiley-Interscience, 1975.
- [33] SAVI. (2018, October) Smart applications on virtual infrastructure. [Online]. Available: <http://www.savinetwork.ca>
- [34] D. P. Heyman and M. J. Sobel, *Stochastic Models in Operations Research*. Dover, 2004, vol. 1.
- [35] R. Ghosh, F. Longo, V. K. Naik, and K. S. Trivedi, "Modeling and performance analysis of large scale iaas clouds," *Future Generation Computer Systems*, July 2012.
- [36] SciPy. (2016, 6) A python-based ecosystem of open-source software for mathematics, science, and engineering. [Online]. Available: <http://scipy.org>
- [37] Y. Rochman, H. Levy, and E. Brosh, "Dynamic placement of resources in cloud computing and network applications," *Performance Evaluation*, vol. 115, pp. 1–37, 2017.
- [38] H. Raei, N. Yazdani, and R. Shojaei, "Modeling and performance analysis of cloudlet in mobile cloud computing," *Performance Evaluation*, vol. 107, pp. 34–53, 2017.
- [39] H. Khazaee, J. Mišić, and V. B. Mišić, "Performance of cloud centers with high degree of virtualization under batch task arrivals," *IEEE Transactions on Parallel and Distributed Systems*, vol. 24, no. 12, pp. 2429–2438, December 2013.
- [40] D. Bruneo, "A stochastic model to investigate data center performance and qos in iaas cloud computing systems," *Parallel and Distributed Systems, IEEE Transactions on*, vol. 25, no. 3, pp. 560–569, 2014.
- [41] S. Vakiliinia, M. M. Ali, and D. Qiu, "Modeling of the resource allocation in cloud computing centers," *Computer Networks*, vol. 91, pp. 453–470, 2015.
- [42] K. Salah, K. Elbadawi, and R. Boutaba, "An analytical model for estimating cloud resources of elastic services," *Journal of Network and Systems Management*, pp. 1–24, 2015.
- [43] H. Khazaee, J. Mišić, V. B. Mišić, and S. Rashwand, "Analysis of a pool management scheme for cloud computing centers," *IEEE Transactions on Parallel and Distributed Systems*, vol. 24, no. 5, pp. 849–861, 2013.
- [44] M. Gribaudo, M. Iacono, and D. Manini, "Performance evaluation of replication policies in microservice based architectures," *Electronic Notes in Theoretical Computer Science*, vol. 337, pp. 45–65, 2018.
- [45] —, "Performance evaluation of massively distributed microservices based applications," in *31st European Conference on Modelling and Simulation, ECMS 2017*. European Council for Modelling and Simulation, 2017, pp. 598–604.
- [46] M. Villamizar, O. Garces, L. Ochoa, H. Castro, L. Salamanca, M. Verano, R. Casallas, S. Gil, C. Valencia, A. Zambrano *et al.*, "Infrastructure cost comparison of running web applications in the cloud using aws lambda and monolithic and microservice architectures," in *2016 16th IEEE/ACM International Symposium on Cluster, Cloud and Grid Computing (CC-Grid)*. IEEE, 2016, pp. 179–182.
- [47] V. Heorhiadi, S. Rajagopalan, H. Jamjoom, M. K. Reiter, and V. Sekar, "Gremlin: Systematic resilience testing of microservices," in *2016 IEEE 36th International Conference on Distributed Computing Systems (ICDCS)*. IEEE, 2016, pp. 57–66.
- [48] T. Inagaki, Y. Ueda, and M. Ohara, "Container management as emerging workload for operating systems," in *2016 IEEE International Symposium on Workload Characterization (IISWC)*. IEEE, 2016, pp. 1–10.
- [49] T. Ueda, T. Nakaike, and M. Ohara, "Workload characterization for microservices," in *2016 IEEE international symposium on workload characterization (IISWC)*. IEEE, 2016, pp. 1–10.
- [50] VMware, Inc. (2016, 6) Docker containers performance in vmware vsphere. [Online]. Available: <https://blogs.vmware.com/performance/2014/10/docker-containers-performance-vmware-vsphere.html>
- [51] W. Felter, A. Ferreira, R. Rajamony, and J. Rubio, "An updated performance comparison of virtual machines and linux containers," in *Performance Analysis of Systems and Software (ISPASS), 2015 IEEE International Symposium On*. IEEE, 2015, pp. 171–172.
- [52] U. Gupta, "Comparison between security majors in virtual machine and linux containers," *arXiv preprint arXiv:1507.07816*, 2015.
- [53] M. Villamizar, O. Garces, H. Castro, M. Verano, L. Salamanca, R. Casallas, and S. Gil, "Evaluating the monolithic and the microservice architecture pattern to deploy web applications in the cloud," in *Computing Colombian Conference*. IEEE, 2015, pp. 583–590.



Hamzeh Khazaee, PhD. is an assistant professor in the Department of Electrical Engineering and Computer Science at York University. Previously he was an assistant professor at the University of Alberta, a research associate at the University of Toronto and a research scientist at IBM, respectively. He received his PhD degree in Computer Science from the University of Manitoba, where he extended queuing theory and stochastic processes to accurately model the performance and availability of cloud computing systems. His research interests include performance modelling, cloud computing and engineering distributed systems.



Nima Mahmoudi received two BS degrees in Electronics and Telecommunications and his MS degree in Digital Electronics from Amirkabir University of Technology, Iran in 2014, 2016, and 2017 respectively. He is currently working towards the PhD degree in software engineering and intelligent systems at the University of Alberta. He is a Research Assistant at the University of Alberta and a visiting Research Assistant in the Performant and Available Computing Systems (PACS) lab at York University. His research interests include serverless computing, cloud computing, performance modelling, applied machine learning, and distributed systems. He is a graduate student member of the IEEE.



Cornel Barna, PhD. is a Professor at Seneca Collage, School of Information and Communications Technology. Prior to joining Seneca Collage, he was a postdoctoral fellow at York University where he obtained his PhD in computer science as well. He obtained his MSc and BSc in computer science from Cuza University, Romania. His main research area is adaptive algorithms, web applications in cloud, heuristics & metaheuristics, and management of containerized software.



Marin Litoiu, PhD, Peng. is a Professor in the Department of Electrical Engineering and Computer Science and in the School of Information Technology, York University. He leads the Adaptive Software Research Lab and focuses on making large software systems more versatile, resilient, energy-efficient, self-healing and self-optimizing. His research won many awards including the IBM Canada CAS Research Project of the Year Award and the IBM CAS Faculty Fellow of the Year Award for his "impact on IBM people, processes and technology."