

Further Investigation on Classical Multiparty computation using Quantum Resources

Hao Cao,^{1,2,*} Wenping Ma,^{1,†} Ge Liu,^{1,‡} and Liangdong Lyu^{1,3,§}

¹State Key Laboratory of Integrated Service Networks, Xidian University, Xi'an, China 710071

²School of Information and Network Engineering, Anhui Science and Technology University, Chuzhou, China 233100

³Department of Basic Sciences, Air Force Engineering University, Xi'an, 710071, China

(Dated: December 18, 2018)

The tremendous development of cloud computing and network technology makes it possible for multiple people with limited resources to complete a large-scale computing with the help of cloud servers. In order to protect the privacy of clients, secure multiparty computation plays an important role in the process of computing. Recently, Clementi et al[Phys. Rev. A **96**, 062317(2017)] proposed a secure multiparty computation protocol using quantum resources. In their protocol, utilizing only linear classical computing and limited manipulation of quantum information, a method of computing n – variable symmetric Boolean function $f(x_1, x_2, \dots, x_n)$ with degree 2 is proposed, and all clients can jointly compute $f(x_1, x_2, \dots, x_n)$ without revealing their private inputs with the help of a server. They proposed an open problem: are there more simple nonlinear functions like the one presented by them that can be used as subroutines for larger computation protocols? We will give the answer to this question in this paper. Inspired by Clementi et al's work, we continue to explore the quantum realization of Boolean functions. First, we demonstrate a way to compute a class of n – variable symmetric Boolean function f_n^k by using single-particle quantum state $|0\rangle$ and single-particle unitary operations U_k . Second, we show that each n – variable symmetric Boolean function can be represented by the linear combination of $f_n^k (k = 0, 1, \dots, n)$ and each function $f_n^k (2 \leq k \leq n)$ can be used to perform secure multiparty computation. Third, we propose an universal quantum implementation method for arbitrary n – variable symmetric Boolean function $f(x_1, x_2, \dots, x_n)$. Finally, we demonstrate our secure multiparty computation protocol on IBM quantum cloud platform.

I. INTRODUCTION

In the cloud environment, it is very common for a number of clients with limited resource to delegate the server to compute a function of their inputs. If each client would rather not reveal his input information to server and other clients, a special cryptographic model called Secure multiparty computation(SMPC) will be considered for use. The SMPC problem is originated from the Yao's millionaire problem[1], and many classical solutions[1–3] to it have been proposed.

In 1984, a quantum key distribution protocol known as BB84[4], which is completely different from classical cryptography, came into people's vision and attracted wide attention. Since then, various types of quantum cryptographic protocols, such as quantum secret sharing(QSS)[5, 6], quantum secure direct communication(QSDC)[7], quantum key agreement(QKA)[8], quantum privacy comparison(QPC)[9], and so on, have been proposed. Especially, quantum solutions to SMPC problem, i.e., quantum SMPC(QSMPC) [10–14], attracts much attention because of its widely application in electronic voting, online auction, and multiparty data processing.

Recently, Clementi et al[14] proposed a QSMPC protocol in which a number of clients can collaborate to compute a function without revealing their inputs. The function in their protocol is a n – variable symmetric Boolean function with degree 2. They proposed an open problem: are there more

simple nonlinear functions like the one presented by them that can be used as subroutines for larger computation protocols? We will give the answer to this question in this paper. Inspired by Clementi et al's work, we focus on the case of arbitrary symmetric Boolean functions. First, we give a quantum implementation of a class of symmetric Boolean function f_n^k . Second, we show that each n – variable symmetric Boolean function can be represented by linear combination of $f_n^k (k = 0, 1, \dots, n)$ and each function f_n^k can be used to perform secure multiparty computation. Third, we explore an universal quantum implementation method for arbitrary n – variable symmetric Boolean function $f(x_1, x_2, \dots, x_n)$.

The remainder of our work is organized as follows. Section II introduces a method to compute a class of n – variable symmetric Boolean function f_n^k by using single-particle quantum state $|0\rangle$ and single-particle unitary operations U_k . Besides, the quantum implementations of arbitrary symmetric Boolean functions are explored in this section. In section III, we give the description of our QSMPC protocol, i.e., each function $f_n^k (2 \leq k \leq n)$ can be used to perform secure multiparty computation. Section IV analyzes the security of our protocol. In section V, a simulation of our protocol on IBM quantum cloud platform. At last, a conclusion of this paper is given in section VI.

II. THEORY

Our work is a further investigation of Clementi et al's work[14]. In their paper, they focus on computing the n – variable Boolean function f by using the following equations:

$$(U^\dagger)^{\oplus_i x_i} U^{x_n} \dots U^{x_2} U^{x_1} |0\rangle = |f\rangle, \quad (1)$$

* caohao2000854@163.com

† wp'ma@mail.xidian.edu.cn

‡ 446552402@qq.com

§ kelinglv@163.com

and

$$(U^\dagger)^{\oplus_i x_i} V^{r_n} U^{x_n} \dots V^{r_2} U^{x_2} V^{r_1} U^{x_1} |0\rangle = |\bar{r} \oplus f\rangle, \quad (2)$$

where $U = R_y(\frac{\pi}{2}) = \cos\frac{\pi}{4}I - i\sin\frac{\pi}{4}Y$ be the $\frac{\pi}{2}$ rotation around the y axis of the Bloch sphere, $V = R_y(\pi) = \cos\frac{\pi}{2}I - i\sin\frac{\pi}{2}Y$ be the π rotation around the y axis, f be the 2-degree n -variable symmetric Boolean function $f_2^n = \bigoplus_{j=1}^{n-1} [x_{j+1} \times (\bigoplus_{i=1}^j x_i)] = \bigoplus_{1 \leq i < j \leq n} x_i x_j$, $r_i \in \{0, 1\}$ ($i = 1, 2, \dots, n$) and $\bar{r} = \bigoplus_{i=1}^n r_i$.

Define $U_k = R_y(\frac{\pi}{k})$ ($k = 1, 2, \dots, n$) be the $\frac{\pi}{k}$ rotation around the y axis of the Bloch sphere, and $U_0 = I = R_y(0)$ be the identity operation. Then we have the following important arguments about U_k ($k = 1, 2, \dots, n$).

Theorem 1 Let k and h be two nonnegative integers, then the following equation holds:

$$U_k U_h = U_h U_k; \quad U_k^\dagger U_h = U_h U_k^\dagger. \quad (3)$$

Proof. First, $U_k U_h = R_y(\frac{\pi}{k}) R_y(\frac{\pi}{h}) = R_y(\frac{\pi}{k} + \frac{\pi}{h}) = R_y(\frac{\pi}{h} + \frac{\pi}{k}) = R_y(\frac{\pi}{h}) R_y(\frac{\pi}{k}) = U_h U_k$.

Next, $U_h = I U_h = (U_k^\dagger U_k) U_h \Rightarrow U_h = U_k^\dagger U_h U_k \Rightarrow U_h U_k^\dagger = U_k^\dagger U_h$. \square

Theorem 2 Let k be a nonnegative integer, $x_i \in \{0, 1\}$ ($i = 1, 2, \dots, n$).

(1) The single-particle quantum state in the form of $(U_k^\dagger)^{(\sum_i x_i) \bmod k} U_k^{x_n} \dots U_k^{x_2} U_k^{x_1} |0\rangle$ can be regarded as the quantum implementation of a n -variable Boolean function f_n^k , i.e.,

$$(U_k^\dagger)^{(\sum_i x_i) \bmod k} U_k^{x_n} \dots U_k^{x_2} U_k^{x_1} |0\rangle = |f_n^k\rangle. \quad (4)$$

(2) f_n^k is a symmetric Boolean function.

(3) $\deg(f_n^k) \geq k$.

(4) The algebraic normal form of f_n^k contains all monomials with degree k .

(5) Each n -variable symmetric Boolean function can be represented by the linear combination of f_n^k ($k = 0, 1, \dots, n$).

Proof. (1) In order to prove the proposition (1), we only need to show that the quantum state in the form of $(U_k^\dagger)^{(\sum_i x_i) \bmod k} U_k^{x_n} \dots U_k^{x_2} U_k^{x_1} |0\rangle$ is either $|0\rangle$ or $|1\rangle$. Let $wt(x_1, x_2, \dots, x_n) = \sum_i x_i = ak + b$, where $wt(x_1, x_2, \dots, x_n)$ be the weight of (x_1, x_2, \dots, x_n) (i.e., the number of ones in x_1, x_2, \dots, x_n), a and b be two nonnegative integer, and $0 \leq b < k$, then

$$\begin{aligned} & (U_k^\dagger)^{(\sum_i x_i) \bmod k} U_k^{x_n} \dots U_k^{x_2} U_k^{x_1} |0\rangle \\ &= (U_k^\dagger)^{(\sum_i x_i) \bmod k} U_k^{\sum_i x_i} |0\rangle \\ &= (U_k^\dagger)^b U_k^{ak+b} |0\rangle \\ &= (U_k)^{ak} |0\rangle \\ &= [R_y(\frac{\pi}{k})]^{ak} |0\rangle \\ &= R_y(a\pi) |0\rangle \in \{|0\rangle, |1\rangle\}, \end{aligned} \quad (5)$$

Hence, $(U_k^\dagger)^{(\sum_i x_i) \bmod k} U_k^{x_n} \dots U_k^{x_2} U_k^{x_1} |0\rangle$ can be regarded as the quantum implementation of a n -variable Boolean function f_n^k .

(2) From equation(5), we can easily get that $f_n^k = 1$ if and only if $R_y(a\pi)|0\rangle = |1\rangle$, if and only if a be odd. Let a' be a nonnegative integer, we have

$$f_n^k = \begin{cases} 0 & wt(x_1, x_2, \dots, x_n) = 2a'k + b \\ 1 & wt(x_1, x_2, \dots, x_n) = (2a' + 1)k + b \end{cases}.$$

which implies that f_n^k is a symmetric Boolean function.

(3) It is easy to verify the fact that $f_n^k(x_1, x_2, \dots, x_n) = 0$ for each vector (x_1, x_2, \dots, x_n) with $wt(x_1, x_2, \dots, x_n) < k$, which implies $\deg(f_n^k) \geq k$.

(4) Owing to the fact that $f_n^k(x_1, x_2, \dots, x_n) = 1$ for each vector (x_1, x_2, \dots, x_n) with $wt(x_1, x_2, \dots, x_n) = k$, we get that the algebraic normal form of f_n^k contains all monomials with degree k .

(5) From (3) and (4), we can draw that $f_n^0, f_n^1, f_n^2, \dots, f_n^n$ are linearly independent, and they form a basis of n -variable symmetric Boolean functions. Hence, each n -variable symmetric Boolean function can be represented by the linear combination of f_n^k ($k = 0, 1, \dots, n$). \square

From **Theorem 1** and **Theorem 2**, we can easily get the following equation which is the generalization of equation(2).

$$(U^\dagger)^{(\sum_i x_i) \bmod k} V^{r_n} U^{x_n} \dots V^{r_1} U^{x_1} |0\rangle = |\bar{r} \oplus f_n^k\rangle, \quad (6)$$

where $r_i \in \{0, 1\}$ ($i = 1, 2, \dots, n$) and $\bar{r} = \bigoplus_{i=1}^n r_i$.

For convenience of description, we denote the vector (x_1, x_2, \dots, x_1) as x , the vector (r_1, r_2, \dots, r_1) as r , the unitary operation $(U_k^\dagger)^{(\sum_i x_i) \bmod k} U_k^{x_n} \dots U_k^{x_2} U_k^{x_1}$ as $U(n, k, x)$, and the unitary operation $(U^\dagger)^{(\sum_i x_i) \bmod k} V^{r_n} U^{x_n} \dots V^{r_2} U^{x_2} V^{r_1} U^{x_1}$ as $VU(n, k, x, r)$ separately, then equation(4) and equation(6) can be rewritten as follows:

$$U(n, k, x)|0\rangle = |f_n^k\rangle \quad (7)$$

$$VU(n, k, x, r)|0\rangle = |\bar{r} \oplus f_n^k\rangle \quad (8)$$

Theorem 3 Let k and h be two nonnegative integers, then

$$|f_n^k \oplus f_h^n\rangle = \tilde{U}(n, k, x) \tilde{U}(n, h, x) |0\rangle \quad (9)$$

Proof. First, let $r_n = r_{n-1} = \dots = r_2 = 0$ and $r_1 = 1$ in equation (6), we get

$$(U_k^\dagger)^{(\sum_i x_i) \bmod k} U_k^{x_n} \dots U_k^{x_2} U_k^{x_1} |1\rangle = |f_n^k \oplus 1\rangle \quad (10)$$

i.e.,

$$\tilde{U}(n, k, x) |1\rangle = |f_n^k \oplus 1\rangle \quad (11)$$

Next, consider the right hand of the equation(9).

$$\begin{aligned}
& \tilde{U}(n, k, x) \tilde{U}(n, h, x) |0\rangle \\
&= \tilde{U}(n, k, x) |f_n^h\rangle \\
&= \begin{cases} |f_n^k\rangle & \text{if } f_n^h = 0 \\ |f_n^k \oplus 1\rangle & \text{if } f_n^h = 1 \end{cases} \quad (\text{From equation}(10)) \\
&= |f_n^k \oplus f_n^h\rangle
\end{aligned} \tag{12}$$

□

From **Theorem 2(5)** and **Theorem 3**, we can easily get the quantum implementation of an arbitrary symmetric Boolean function.

Theorem 4 Let $f(x_1, x_2, \dots, x_n)$ be a n -variable symmetric Boolean function which can be presented as

$$f = \bigoplus_{k=0}^n a_k f_n^k \tag{13}$$

then

$$|f\rangle = \prod_{k=0}^n [\tilde{U}(n, k, x)]^{a_k} |0\rangle \tag{14}$$

III. QUANTUM SECURE MULTIPARTY COMPUTATION PROTOCOL

In this section, we will show the QSMPC protocol by using equation (6) or equation (8) in the ideal case environment. Let C_i ($i = 1, 2, \dots, n$) be n clients and each client C_i possesses a private input x_i and selects a random bit r_i . They want to jointly compute the function f_k^n ($2 \leq k \leq n$) without revealing their inputs with the help of a server S .

Step 1 First, each client C_i divides his private input x_i into n elements $x_{i,1}, x_{i,2}, \dots$, and $x_{i,n}$ ($x_{i,j} \in \{0, 1, \dots, k-1\}, j = 1, 2, \dots, n$), and the random bit r_i into n elements $r_{i,1}, r_{i,2}, \dots$, and $r_{i,n}$ ($r_{i,j} \in \{0, 1\}, j = 1, 2, \dots, n$), such that $\sum_{j=1}^n x_{i,j} \equiv x_i \pmod{k}$ and $\bigoplus_{j=1}^n r_{i,j} = r_i$. Second, each client C_i sends $x_{i,j}$ and $r_{i,j}$ to client C_j . Third, each client C_i computes $\tilde{x}_i = \sum_{j=1}^n x_{j,i} \pmod{k}$ and $\tilde{r}_i = \bigoplus_{j=1}^n r_{j,i}$.

Step 2 First, the server S prepares a single particle in the state $|0\rangle$ and sends it to the client C_1 . Second, C_1 performs the unitary operation $V^{r_1} U^{x_1}$ on the received single particle according to his private input x_1 and random bit r_1 , and sends the resulted single particle to the client C_2 who will perform the unitary operation $V^{r_2} U^{x_2}$ on the received particle according to his private input x_2 and random bit r_2 . This procession continues until all the clients have applied their unitary operations to the single particle. At this point, the single particle is in the hands of C_n .

Step 3 First, each client C_i sends \tilde{x}_i to the client C_n through an secure authentication channel. Second, C_n calculates $(\sum_{i=1}^n \tilde{x}_i) \pmod{k}$. Third, C_n perform the unitary operation $(U^\dagger)^{(\sum_{i=1}^n \tilde{x}_i) \pmod{k}}$ on the single particle, and the resulted particle will be in the state of $|f_n^k \oplus \bar{r}\rangle$ owing to the fact that $(\sum_{i=1}^n \tilde{x}_i) \pmod{k} = (\sum_{i=1}^n x_i) \pmod{k}$. Fourth, C_n sends the resulted particle back to the server S . At last,

the server S will get the state $|f_n^k \oplus \bar{r}\rangle$ by measuring the received particle, and announce $f_n^k \oplus \bar{r}$ to all clients.

Step 4 First, each client C_i transmits the classical bit $\tilde{r}_i = \bigoplus_{j=1}^n r_{j,i}$ to all other clients through an secure authentication channel. Second, each client C_i calculates $\bigoplus_{j=1}^n \tilde{r}_j = \bigoplus_{j=1}^n \tilde{r}_j = \bar{r}$. At last, every client will extract the value of f_n^k by performing the XOR operation $f_n^k = (f_n^k \oplus \bar{r}) \oplus \bar{r}$.

IV. SECURITY ANALYSIS AND EFFICIENCY COMPARISON OF THE PROPOSED QSMPC PROTOCOL

A. Security Analysis

In this section, we only focus on the internal attack from the clients or the server because internal attacks are usually more effective than external attacks. We assume that both the clients and the server will execute the QSMPC protocol. However, the server S will try to get the private inputs of the clients or the function output f_n^k , and each client will also try to get the private inputs of other clients.

(1) Consider the security against the attack from the server S . First, if the server S wants to extract the private input of some one client, say C_1 , he must intercept the particle sent from C_1 to C_2 , and measures it in the correct measurement basis $\{|0\rangle, |1\rangle\}$ or $\{U_k|0\rangle, U_k|1\rangle\}$. However, he could not choose the right measurement base because he knows nothing about the unitary operation $V^{r_1} U^{x_1}$ and the state information of the single particle. Second, if the server S wants to extract the function output f_n^k . However, he will also fail because he knows nothing about the random classical bits r_i ($i = 1, 2, \dots, n$), \tilde{r}_i ($i = 1, 2, \dots, n$) and \bar{r} .

(2) Consider the security against the attack from the clients. Let us discuss a very unfavorable situation, i.e., the dishonest clients consist of C_n who will get the information of $(\sum_{i=1}^n \tilde{x}_i) \pmod{k}$, and some other $n-t-1$ clients C_{t+1}, \dots, C_{n-1} . They will collaborate to extract the private inputs of C_1, \dots, C_t . Apparently, they could easily access the $(\sum_{i=1}^t \tilde{x}_i) \pmod{k}$ from $(\sum_{i=1}^n \tilde{x}_i) \pmod{k}$ and $x_{t+1}, \dots, x_{n-1}, x_n$. If $t = 1$ (i.e., only one client is honest), they could extract the private input x_1 ; or else, they cannot get any useful information about the private inputs of the honest clients.

B. Efficiency Comparison

In classical case, secure multi-party computation is usually achieved by garbled circuits[15]. Similarly, quantum circuits are usually used to perform quantum secure multi-party computation and a quantum circuit consists of a number of quantum gates. The efficiency evaluation usually includes three indicators: the quantum resource, the size and the number of quantum gates, and classical communication cost involved in the quantum circuit.

Several quantum implementations of classical NAND gate, which are based on either entangled GHZ state or single qubit,

are presented in the previous work[12]. In the procession of performing NAND gate based on single qubit, one qubit, two single-particle unitary operations and several rounds of classical communication are involved. In the procession of performing NAND gate based on single entangled GHZ state, three qubit, Four single-particle unitary operations, and several rounds of classical communication are involved. Besides, their protocols guarantees no security for the inputs of the parties as stated in Clementi et al's work[14]. Quantum implementation of Boolean function and its application in QSMPC are explored in Clementi et al's work[14]. In their protocol, one qubit, $n + 1$ single-particle unitary operations and one round classical communication are needed if there are n clients are involved . Hence, their protocol is more efficient.

Our QSMPC protocol is a generalization of the work by Clementi et al[14]. From the processions of Clementi et al's protocol and ours, we can know that the efficiency of the two protocols is the same.

V. QUANTUM SIMULATION ON IBM QUANTUM CLOUD PLATFORM

We simulates our protocol on IBM quantum cloud platform. Here, we will design the quantum circuits to fit the ibmqx4 quantum computer. Suppose the preparation and measurement of the qubit are operated by the server(i.e., q[0], q[1], q[2], q[3] and q[4]). The private inputs of n clients and the random classical bits selected by them can be represented as $x = (x_1, x_2, \dots, x_n)$ and $r = (r_1, r_2, \dots, r_n)$. Fig.1 shows the quantum circuits of our protocol with $n = 5$, $n = 8$, and $n = 10$. The definition of the operation $VU(n, k, x, r)$ can be seen in equation(8). The unitary operation U_k is realized by the quantum gate $U_3(\frac{\pi}{k}, 0, 0)$, the unitary operation V is realized by the quantum gate $U_3(\pi, 0, 0)$ and the unitary operation I is realized by the quantum gate id instead of $U_3(0, 0, 0)$ in the IBM quantum cloud platform.

Case 1: $n = 5$. let C_1, C_2, \dots , and C_5 be the five clients. They will collaborate to compute the function f_5^2, f_5^3 , and f_5^4 with $x = (x_1, x_2, \dots, x_5) = (1, 1, 0, 0, 1)$, $r = (r_1, r_2, \dots, r_5) = (1, 0, 0, 1, 0)$, $(\sum_{i=1}^5 x_i) \bmod 2 = 1$, $(\sum_{i=1}^5 x_i) \bmod 3 = 0$, $(\sum_{i=1}^5 x_i) \bmod 4 = 3$ and $\bar{r} = \bigoplus_{i=1}^5 r_i = 0$. The quantum implementation of $f_5^k (k = 2, 3, 4)$ can be seen in Fig.1(a). Here, $VU(5, 2, x, r) = (U^\dagger)^{(\sum_{i=1}^5 x_i) \bmod 2} V^{r_5} U_2^{x_5} V^{r_5} U_2^{x_5} V^{r_4} U_2^{x_4} V^{r_3} U_2^{x_3} V^{r_2} U_2^{x_2} V^{r_1} U_2^{x_1} = U_2^\dagger V^0 U_2^1 V^1 U_2^0 V^0 U_2^0 V^0 U_2^1 V^1 U_2^1 = U_2^\dagger I U_2 V I I I I U_2 V U_2$. Similarly, $VU(5, 3, x, r) = (U_3^\dagger)^0 I U_3 V I I I I U_3 V U_3$ and $VU(5, 4, x, r) = (U_4^\dagger)^3 I U_4 V I I I I U_4 V U_4$. The measurement results can be seen in Fig.2, and the probabilities of output $f_5^k (k = 2, 3, 4)$ correctly can be seen in TableI.

Case 2: $n = 8$. let C_1, C_2, \dots , and C_8 be the eight clients. They will collaborate to compute the function $f_8^2, f_8^3, f_8^4, f_8^5$, and f_8^6 with $x = (x_1, x_2, \dots, x_8) = (1, 0, 1, 1, 1, 0, 1, 0)$, $r = (r_1, r_2, \dots, r_8) = (1, 1, 1, 0, 0, 1, 0, 0)$, $(\sum_{i=1}^8 x_i) \bmod 2 = 1$, $(\sum_{i=1}^8 x_i) \bmod 3 = 2$, $(\sum_{i=1}^8 x_i) \bmod 4 = 1$, $(\sum_{i=1}^8 x_i) \bmod 5 = 0$, $(\sum_{i=1}^8 x_i) \bmod 6 = 5$ and $\bar{r} = \bigoplus_{i=1}^8 r_i = 0$.

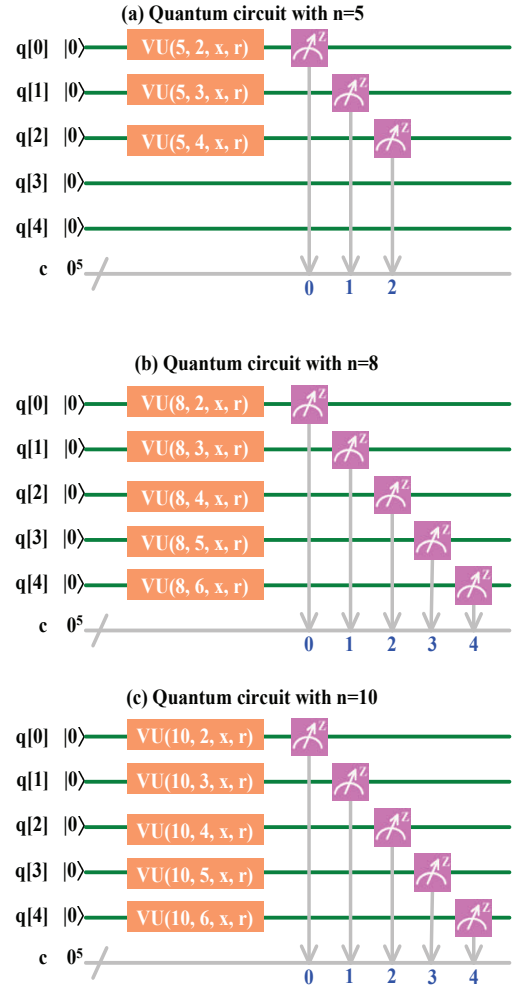

FIG. 1. (Color online) Quantum implementation of our protocol with $n = 5$, $n = 8$, and $n = 10$. (a) The quantum circuit will output (f_5^4, f_5^3, f_5^2) by measuring $q[2]$, $q[1]$ and $q[0]$. (b) The quantum circuit will output $(f_8^6, f_8^5, f_8^4, f_8^3, f_8^2)$ by measuring $q[4]$, $q[3]$, $q[2]$, $q[1]$ and $q[0]$. (c) The quantum circuit will output $(f_{10}^6, f_{10}^5, f_{10}^4, f_{10}^3, f_{10}^2)$ by measuring $q[4]$, $q[3]$, $q[2]$, $q[1]$ and $q[0]$.

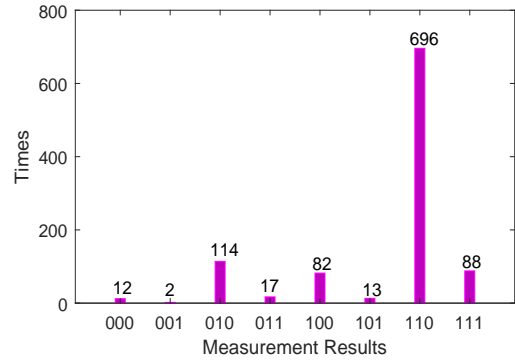

FIG. 2. (Color online) Measurement results (f_5^4, f_5^3, f_5^2) : $(0, 0, 0)$ occurred 12 times, $(0, 0, 1)$ occurred 82 times, \dots , $(1, 1, 1)$ occurred 88 times and a total of 1024 times.

TABLE I. Statistics of output f_5^k correctly

Boolean function	Correct value	times	Probability
f_5^2	1	879	85.84%
f_5^3	1	915	89.36%
f_5^4	0	904	88.28%

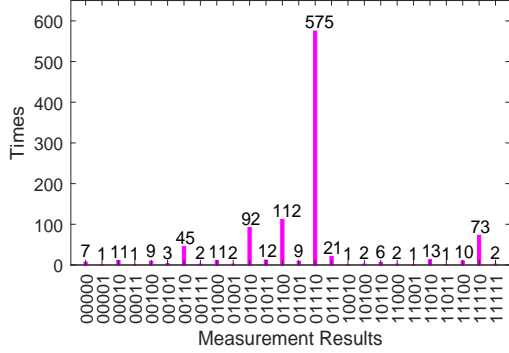

FIG. 3. (Color online) Measurement results ($f_8^6 \oplus 1, f_8^5 \oplus 1, f_8^4 \oplus 1, f_8^3 \oplus 1, f_8^2 \oplus 1$): (0, 0, 0, 0, 0) occurred 7 times, (0, 0, 0, 0, 1) occurred 1 times, \dots , (1, 1, 1, 1, 1) occurred 2 times and a total of 1024 times. Besides, the results (1, 0, 0, 0, 1), (1, 0, 0, 1, 1), (1, 0, 1, 0, 1), (1, 0, 1, 1, 1) and (1, 1, 1, 0, 1) did not appear.

The quantum implementation of f_8^k ($k = 2, 3, 4, 6, 6$) can be seen in Fig.1(b). Here, $VU(8, 2, x, r) = U_2^\dagger II IU_2 VI IU_2 IU_2 VU_2 VI VU_2$, $VU(8, 3, x, r) = (U_3^\dagger)^2 II IU_3 VI IU_3 IU_3 VU_3 VI VU_3$, $VU(8, 4, x, r) = U_4^\dagger II IU_4 VI IU_4 IU_4 VU_4 VI VU_4$, $VU(8, 5, x, r) = (U_5^\dagger)^0 II IU_5 VI IU_5 IU_5 VU_5 VI VU_5$, and $VU(8, 6, x, r) = (U_6^\dagger)^5 II IU_6 VI IU_6 IU_6 VU_6 VI VU_6$. The measurement results ($f_8^2 \oplus \bar{r}, f_8^3 \oplus \bar{r}, f_8^4 \oplus \bar{r}, f_8^5 \oplus \bar{r}, f_8^6 \oplus \bar{r}$) = ($f_8^2, f_8^3, f_8^4, f_8^5, f_8^6$) can be seen in Fig.3, and the probabilities of output f_8^k ($k = 2, 3, 4, 5, 6$) correctly can be seen in TableII.

Case 3: $n = 10$. let C_1, C_2, \dots , and C_{10} be the eight clients. They will collaborate to compute the function $f_{10}^2, f_{10}^3, f_{10}^4, f_{10}^5$, and f_{10}^6 with $x = (x_1, x_2, \dots, x_{10}) = (1, 0, 1, 0, 1, 0, 1, 0, 1, 0)$, $r = (r_1, r_2, \dots, r_{10}) =$

TABLE II. Statistics of output f_8^k correctly

Boolean function	Correct value	times	Probability
f_8^2	0	969	94.63%
f_8^3	1	855	83.50%
f_8^4	1	869	84.86%
f_8^5	1	936	91.41%
f_8^6	0	913	89.16%

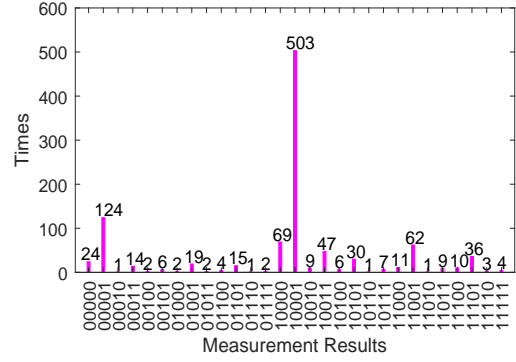

FIG. 4. (Color online) Measurement results ($f_{10}^6 \oplus 1, f_{10}^5 \oplus 1, f_{10}^4 \oplus 1, f_{10}^3 \oplus 1, f_{10}^2 \oplus 1$): (0, 0, 0, 0, 0) occurred 24 times, (0, 0, 0, 0, 1) occurred 124 times, \dots , (1, 1, 1, 1, 1) occurred 4 times and a total of 1024 times. Besides, the results (0, 0, 1, 0, 1), (0, 0, 1, 1, 1) and (0, 1, 0, 1, 0) did not appear.

TABLE III. Statistics of output f_{10}^k correctly

Boolean function	Correct value	times	Probability
f_{10}^2	0	880	85.94%
f_{10}^3	1	923	90.14%
f_{10}^4	1	897	87.60%
f_{10}^5	1	843	82.32%
f_{10}^6	0	808	78.91%

(1, 0, 1, 1, 0, 0, 1, 0, 1, 0), $(\sum_i^{10} x_i) \bmod 2 = 1$, $(\sum_i^{10} x_i) \bmod 3 = 2$, $(\sum_i^{10} x_i) \bmod 4 = 1$, $(\sum_i^{10} x_i) \bmod 5 = 0$, $(\sum_i^{10} x_i) \bmod 6 = 5$ and $\bar{r} = \bigoplus_{i=1}^{10} r_i = 1$. The quantum implementation of f_{10}^k ($k = 2, 3, 4, 5, 6$) can be seen in Fig.1(c). Here, $VU(10, 2, x, r) = U_2^\dagger II VU_2 II VU_2 II IU_2 VI VU_2 II VU_2$, $VU(10, 3, x, r) = (U_3^\dagger)^2 II VU_3 II VU_3 II IU_3 VI VU_3 II VU_3$, $VU(10, 4, x, r) = U_4^\dagger II VU_4 II VU_4 II IU_4 VI VU_4 II VU_4$, $VU(10, 5, x, r) = (U_5^\dagger)^0 II VU_5 II VU_5 II IU_5 VI VU_5 II VU_5$, and $VU(10, 6, x, r) = (U_6^\dagger)^5 II VU_6 II VU_6 II IU_6 VI VU_6 II VU_6$. The measurement results ($f_{10}^6 \oplus \bar{r}, f_{10}^5 \oplus \bar{r}, f_{10}^4 \oplus \bar{r}, f_{10}^3 \oplus \bar{r}, f_{10}^2 \oplus \bar{r}$) = ($f_{10}^6 \oplus 1, f_{10}^5 \oplus 1, f_{10}^4 \oplus 1, f_{10}^3 \oplus 1, f_{10}^2 \oplus 1$) can be seen in Fig.4, and the probabilities of output f_{10}^k ($k = 2, 3, 4, 5, 6$) correctly can be seen in TableII.

VI. CONCLUSION

In this paper, we solves an open problem proposed by Clementi et al[14]. Inspired by Clementi et al's work, we explore the quantum realization of symmetric Boolean functions and demonstrate that a class of $n - variable$ symmetric Boolean functions f_n^k can be implemented by quantum circuits. Besides, each function f_n^k ($2 \leq k \leq n$) can be used to

perform secure multiparty computation and each n -variable symmetric Boolean function can be represented by the linear combination of f_n^k ($k = 0, 1, \dots, n$). Also, we propose an universal quantum implementation method for arbitrary n -variable symmetric Boolean function $f(x_1, x_2, \dots, x_n)$. At last, we demonstrate our secure multiparty computation protocol on IBM quantum cloud platform.

ACKNOWLEDGMENTS

This work was supported in part by the National Key R&D Program of China under Grant 2017YFB0802400, the National Science Foundation of China under Grant 61373171, 61702007 and 11801564, the 111 Project under Grant B08038, and the Key Project of Science Research of Anhui Province under Grant KJ2017A519, the Natural Science Foundation of Shaanxi Province under Grant No.2017JQ1032, the Basic Research Project of Natural Science of Shaanxi Province under Grant 2017JM6037.

-
- [1] A. C.Yao, in proceedings of the 23rd Annual Symposium on Foundations of Computer Science(IEEE Computer Society, Washington, DC,1982), pp.160-164.
- [2] A. C.Yao, in proceedings of the 27rd Annual Symposium on Foundations of Computer Science(IEEE Computer Society, Toronto, 1986), pp.162-167.
- [3] O. Goldreich, S. Micali, and A. Wigderson, in Annual ACM Symposium on Theory of Computing (ACM, New York, 1987), pp.218.
- [4] C. H.Bennett and G.Brassard, in proceedings of International Conference on Computer System and Signal Processing (Bangalore, India, 1984), pp.175-179.
- [5] M. Hillery, V. Buzek and A. Berthiaume, Phys. Rev. A **59**, 1829(1999).
- [6] H. Cao and W. Ma, IEEE. Photonics. J **9**, 7600207(2017).
- [7] W. Zhang, D. S. Ding, Y. B. Sheng, et al, Phys. Rev. Lett **118**, 220501(2017).
- [8] H. Cao and W. Ma, Laser. Phys. Lett **15**, 095201(2018).
- [9] H. Y. Tseng, J. Lin and T. Hwang, Quantum. Inf. Process **11**, 373(2012).
- [10] J. Anders and D. E. Browne, Phys. Rev. Lett **102**, 050502(2009).
- [11] K. Loukopoulos and D. E. Browne, Phys. Rev. A **81**, 062336(2010).
- [12] V. Dunjko, T. Kapourniotis, and E. Kashefi, J. Quantum. Inform. Comput **16**, 0061 (2016).
- [13] S. Barz, V. Dunjko, and F. Schlederer, et al, Phys. Rev. A **93**, 032339 (2016).
- [14] M. Clementi, A. Pappa, and A. Eckstein, et al, Phys. Rev. A **96**, 062317(2017).
- [15] Y. Huang, D. Evans, and J. Katz, et al, in Proceedings of the 20th USENIX Security Symposium, (USENIX, San Francisco, CA, 2011), pp. 331-335.