

$(0, 4)$ brane box models

Amihay Hanany¹

*Theoretical Physics, The Blackett Laboratory, Imperial College London,
Prince Consort Road, London, SW7 2AZ United Kingdom*

and

Tadashi Okazaki²

*Perimeter Institute for Theoretical Physics,
Waterloo, Ontario, N2L 2Y5 Canada*

Abstract

Two-dimensional $\mathcal{N} = (0, 4)$ supersymmetric quiver gauge theories are realized as D3-brane box configurations (two dimensional intervals) which are bounded by NS5-branes and intersect with D5-branes. The periodic brane configuration is mapped to D1-D5-D5' brane system at orbifold singularity via T-duality. The matter content and interactions are encoded by the $\mathcal{N} = (0, 4)$ quiver diagrams which are determined by the brane configurations. The Abelian gauge anomaly cancellation indicates the presence of Fermi multiplets at the NS-NS' junction. We also discuss the brane construction of $\mathcal{N} = (0, 4)$ supersymmetric boundary conditions in 3d $\mathcal{N} = 4$ gauge theories involving two-dimensional boundary degrees of freedom that cancel gauge anomaly.

¹a.hanany@imperial.ac.uk

²tokazaki@perimeterinstitute.ca

Contents

1	Introduction	2
2	$\mathcal{N} = (0, 4)$ supersymmetric theories	3
2.1	$\mathcal{N} = (0, 2)$ superspace	3
2.2	$\mathcal{N} = (0, 4)$ supersymmetric theories	6
3	$\mathcal{N} = (0, 4)$ boundary conditions	9
3.1	Brane construction	9
3.2	$\mathcal{N} = (0, 4)$ boundary conditions	9
3.3	Boundary anomaly and linking number	11
3.4	Brane box configuration	13
4	D1-D5-KK system	13
4.1	D1-branes on $\mathbb{C}^2/\mathbb{Z}_k \times \mathbb{C}^2/\mathbb{Z}_{k'}$	13
4.2	D1-D5-D5' branes	25
4.3	D1-D5-D5' branes on $\mathbb{C}^2/\mathbb{Z}_k \times \mathbb{C}^2/\mathbb{Z}_{k'}$	27
4.4	Examples	31
5	Brane box model	32
5.1	Brane box configuration and anomaly	32
5.2	Brane box with flavor 5-branes	36
5.3	2d-3d coupled system	37

1 Introduction

$\mathcal{N} = (0, 4)$ supersymmetric field theories are less understood due to the difficulty with their construction and quantization, however, they involve intriguing aspects and applications.

$\mathcal{N} = (0, 4)$ supersymmetric sigma model has the Yukawa couplings which can obey the ADHM equations of the instanton construction under certain assumptions [1]. This indicates that there exists a certain $\mathcal{N} = (0, 4)$ sigma model for every instanton. Since then, there have been a lot of studies of $\mathcal{N} = (0, 4)$ supersymmetric field theories. The classical aspects of $\mathcal{N} = (0, 4)$ supermultiplets and off-shell formalism were studied in [2, 3, 4] and quantum properties were studied in [5]. The elliptic genera or superconformal indices of $\mathcal{N} = (0, 4)$ gauge theories have been computed in [6, 7].

$\mathcal{N} = (0, 4)$ superconformal field theory also can play a significant role in string and M-theory to describe the dynamics of intersecting brane configurations and many features of the holographic dual supergravity solutions. One relevant example is the D1-D5-KK system which is a 1/8 BPS configuration in Type IIB string theory. It is dual to the triple intersection of M5-branes [8, 9]. The dual $\mathcal{N} = (0, 4)$ SCFT is studied in [10, 11]. Another relevant example is the D1-D5-D5' system whose near horizon geometry is the geometry $AdS_3 \times S^3 \times S^3 \times \mathbb{R}$ [12, 13, 14]. The $\mathcal{N} = (0, 4)$ gauged theory which lives on the common world-volume of D1-branes and intersecting D5-branes is studied in [15].

In this paper, we present a novel construction of $\mathcal{N} = (0, 4)$ supersymmetric quiver gauge theories from brane box configuration of D3-branes which intersect with NS5-, D5-, NS5'- and D5'-branes. $\mathcal{N} = (0, 4)$ supersymmetry can be preserved by half BPS boundary conditions in 3d $\mathcal{N} = 4$ supersymmetric field theory [16] and these boundary conditions can be realized in brane setup by starting

with Hanany-Witten setup [17] and introducing additional NS5' and D5'-branes on which half-infinite D3-branes can end. We promote this setup to define $\mathcal{N} = (0, 4)$ supersymmetric gauge theory by displacing D3-branes between NS5- and NS5'-branes. We call this brane configuration the D3-brane box model. The periodic D3-brane box model turns out to be T-dual to the D1-D5-D5' brane system probing orbifold singularity, which is a generalization of the D1-D5-KK system and D1-D5-D5' system.

In section 2 we start with reviewing $\mathcal{N} = (0, 4)$ supersymmetry in two dimensions. We make use of $\mathcal{N} = (0, 2)$ notation to formulate $\mathcal{N} = (0, 4)$ theories. In section 3 we realize $\mathcal{N} = (0, 4)$ supersymmetric boundary conditions for 3d $\mathcal{N} = 4$ gauge theories by adding extra 5-branes in Hanany-Witten construction and promoting to brane box configuration in Type IIB string theory. In section 4 we study the D1-D5-D5'-KK-KK' system which is T-dual of the brane box configuration. We determine the spectrum and interaction by using the techniques developed in [18]. We propose $\mathcal{N} = (0, 4)$ quiver which can be read from the brane box configuration and the D1-D5-D5'-KK-KK' system. In section 5 we analyze the anomaly in brane box model. We discuss that the cancellation of the Abelian anomaly in brane box model requires the existence of tetravalent Fermi multiplet charged under the Abelian parts for quadrants of D3-branes which lives at the NS5-NS5' junction. Furthermore, we argue the brane construction of $\mathcal{N} = (0, 4)$ supersymmetric boundary conditions in 3d $\mathcal{N} = 4$ supersymmetric gauge theory involving two-dimensional boundary degrees of freedom which cancel gauge anomaly.

2 $\mathcal{N} = (0, 4)$ supersymmetric theories

2.1 $\mathcal{N} = (0, 2)$ superspace

There are four types of supermultiplets for $\mathcal{N} = (0, 4)$ supersymmetry in two dimensions. Let us start by introducing the notation and convention in $\mathcal{N} = (0, 2)$ superspace³. The $\mathcal{N} = (0, 2)$ superspace is parametrized by bosonic coordinates x^\pm and fermionic coordinates $\{\theta^+, \bar{\theta}^+\}$ where the spinor conventions are as in [19, 20, 21]. The supercharges Q_+ and $\bar{Q}_+ = Q_+^\dagger$ of chiral $\mathcal{N} = (0, 2)$ supersymmetry in the superspace is given by

$$Q_+ = \frac{\partial}{\partial\theta^+} + i\bar{\theta}^+ \partial_+, \quad \bar{Q}_+ = -\frac{\partial}{\partial\bar{\theta}^+} - i\theta^+ \partial_+. \quad (2.1)$$

They satisfy

$$\{Q_+, Q_+\} = \{\bar{Q}_+, \bar{Q}_+\} = 0, \quad \{Q_+, \bar{Q}_+\} = -2i\partial_+. \quad (2.2)$$

The superderivatives are

$$D_+ = \frac{\partial}{\partial\theta^+} - i\bar{\theta}^+ \partial_+, \quad \bar{D}_+ = -\frac{\partial}{\partial\bar{\theta}^+} + i\theta^+ \partial_+ \quad (2.3)$$

which obey

$$\{D_+, D_+\} = \{\bar{D}_+, \bar{D}_+\} = 0, \quad \{D_+, \bar{D}_+\} = 2i\partial_+ \quad (2.4)$$

and anticommute with the supercharges

$$\{D_+, Q_+\} = 0, \quad \{D_+, \bar{Q}_+\} = 0, \quad \{\bar{D}_+, Q_+\} = 0, \quad \{\bar{D}_+, \bar{Q}_+\} = 0. \quad (2.5)$$

Note that superfields are functions of $(x^\pm, \theta^+, \bar{\theta}^+)$ with constraints in terms of \bar{D}_+ , which annihilates combinations of $y^+ = x^+ - i\theta^+\bar{\theta}^+$, $y^- = x^-$ and θ^+ .

³ The superspace formalism for $\mathcal{N} = (0, 4)$ supersymmetry is given in [3, 4].

$\mathcal{N} = (0, 2)$ **gauge multiplets** For simplicity, we focus on Abelian gauge theory. The $\mathcal{N} = (0, 2)$ gauge multiplet consists of a real adjoint valued superfield \mathcal{A}_+ , whose lowest component is the right-moving component of gauge field, and \mathcal{A}_- whose lowest component is the left-moving component of gauge field. A supergauge transformation is

$$\mathcal{A}_+ \rightarrow \mathcal{A}_+ - i(\Lambda - \bar{\Lambda}), \quad \mathcal{A}_- \rightarrow \mathcal{A}_- - i(\Lambda + \bar{\Lambda}) \quad (2.6)$$

where Λ is a chiral superfield $\bar{D}_+\Lambda = \bar{D}_+\bar{\Lambda} = 0$. In the Wess-Zumino gauge, the real superfields \mathcal{A}_+ and \mathcal{A}_- have the component expansions

$$\mathcal{A}_+ = \theta^+\bar{\theta}^+(A_0 + A_1), \quad \mathcal{A}_- = (A_0 - A_1) - 2i\theta^+\bar{\lambda}_- - 2i\bar{\theta}^+\lambda_- + 2\theta^+\bar{\theta}^+D \quad (2.7)$$

Here the left-moving component $A_- = A_0 - A_1$ of the gauge field has two real left-moving fermionic partners λ_- and $\bar{\lambda}_-$ while the right-moving one $A_+ = A_0 + A_1$ has none. D is a real auxiliary field.

In gauge theories, the superspace derivatives D_+ and \bar{D}_+ are extended to gauge covariant superderivatives $\mathcal{D}_+ = e^{-\mathcal{A}_+}D_+e^{\mathcal{A}_+}$ and $\bar{\mathcal{D}}_+ = e^{\bar{\mathcal{A}}_+}\bar{D}_+e^{-\bar{\mathcal{A}}_+}$. In the Wess-Zumino gauge they are expressed as

$$\mathcal{D}_0 + \mathcal{D}_1 = \partial_0 + \partial_1 + i\mathcal{A}_+, \quad \mathcal{D}_0 - \mathcal{D}_1 = \partial_0 - \partial_1 + i\mathcal{A}_-, \quad (2.8)$$

$$\mathcal{D}_+ = \frac{\partial}{\partial\theta^+} - i\bar{\theta}^+(\mathcal{D}_0 + \mathcal{D}_1), \quad \bar{\mathcal{D}}_+ = -\frac{\partial}{\partial\bar{\theta}^+} + i\theta^+(\mathcal{D}_0 + \mathcal{D}_1). \quad (2.9)$$

The field strength is given by the uncharged Fermi multiplet

$$\begin{aligned} \Upsilon &= [\bar{\mathcal{D}}_+, \mathcal{D}_0 - \mathcal{D}_1] = \bar{\mathcal{D}}_+(\partial_- \mathcal{A}_+ + i\mathcal{A}_-) \\ &= -2[\lambda_-(y) - i\theta^+(D - iF_{01})] \\ &= -2[\lambda_-(x) - i\theta^+(D - iF_{01}) - i\theta^+\bar{\theta}^+(\mathcal{D}_0 + \mathcal{D}_1)\lambda_-] \end{aligned} \quad (2.10)$$

where $F_{01} = \partial_0 A_1 - \partial_1 A_0$. The kinetic terms for the $\mathcal{N} = (0, 2)$ gauge multiplets are given by integration over all of superspace $d^2\theta = d\theta^+d\bar{\theta}^+$

$$\begin{aligned} S_{\text{gauge}}^{(0,2)} &= \frac{1}{8e^2} \int d^2x d^2\theta \bar{\Upsilon} \Upsilon \\ &= \frac{1}{e^2} \int d^2x \left[\frac{1}{2} F_{01}^2 + i\bar{\lambda}_-(\partial_0 + \partial_1)\lambda_- + \frac{1}{2} D^2 \right]. \end{aligned} \quad (2.11)$$

2.1.1 $\mathcal{N} = (0, 2)$ chiral multiplets

The $\mathcal{N} = (0, 2)$ chiral superfield Φ satisfies the chirality constraint

$$\bar{D}_+\Phi = 0. \quad (2.12)$$

It is expanded in the (super)coordinates $y^+ = x^+ - i\theta^+\bar{\theta}^+$, $y^- = x^-$ and θ^+ as

$$\begin{aligned} \Phi &= \phi(y) + \sqrt{2}\theta^+\psi_+(y) \\ &= \phi(x) + \sqrt{2}\theta^+\psi_+(x) - i\theta^+\bar{\theta}^+\partial_+\phi(x) \end{aligned} \quad (2.13)$$

where ϕ is complex scalar and ψ_+ is its right-moving fermionic partner. The kinetic terms for the $\mathcal{N} = (0, 2)$ chiral superfield are given by

$$S_{\text{chiral}}^{(0,2)} = -\frac{i}{2} \int d^2x d^2\theta \bar{\Phi} \partial_- \Phi. \quad (2.14)$$

For a field $\Phi^{(Q)}$ with $U(1)$ charge Q , the covariant chirality constraint $\bar{D}_+\Phi^{(Q)} = 0$ can be solved by $\Phi = e^{-Q\mathcal{A}}\bar{\Phi}^{(Q)}$. In components we have

$$\Phi = \phi(x) + \sqrt{2}\theta^+\psi_+(x) - i\theta^+\bar{\theta}^+(D_0 + D_1)\phi(x) \quad (2.15)$$

where $D_\alpha = \partial_\alpha + iQ u_\alpha$. The kinetic terms for the $\mathcal{N} = (0, 2)$ charged chiral superfield are given by

$$\begin{aligned} S_{\text{chiral}}^{(0,2)} &= -\frac{i}{2} \int d^2x d^2\theta \bar{\Phi}^{(Q)} (\mathcal{D}_0 - \mathcal{D}_1) \Phi^{(Q)} \\ &= \int d^2x \left[-|D_\alpha\phi|^2 + i\bar{\psi}_+(D_0 - D_1)\psi_+ - iQ\sqrt{2}\bar{\phi}\lambda_-\psi_+ + iQ\sqrt{2}\phi\bar{\psi}_+\bar{\lambda}_- + QD|\phi|^2 \right]. \end{aligned} \quad (2.16)$$

2.1.2 $\mathcal{N} = (0, 2)$ Fermi multiplets

The $\mathcal{N} = (0, 2)$ Fermi multiplets satisfy the conditions

$$\bar{D}_+\Gamma = \sqrt{2}E, \quad \bar{D}_+E = 0. \quad (2.17)$$

Here E determines the potential term and it can be solved by assuming that E is a holomorphic function of chiral superfields Φ [20]. The $\mathcal{N} = (0, 2)$ Fermi multiplet is expanded in the coordinates as

$$\Gamma = \chi_-(x) - \sqrt{2}\theta^+G(x) - i\theta^+\bar{\theta}^+(D_0 + D_1)\chi_-(x) - \sqrt{2}\bar{\theta}^+E \quad (2.18)$$

where χ_- is a left-moving fermion and G is a complex auxiliary field. In general E will have an expansion

$$E(\Phi) = E(\phi_i) + \sqrt{2}\theta^+\frac{\partial E}{\partial\phi^i}\psi_{+i} - i\theta^+\bar{\theta}^+(D_0 + D_1)E(\phi_i). \quad (2.19)$$

The $\mathcal{N} = (0, 2)$ Fermi multiplets may also transform as some representation R of the gauge group. For a field $\Gamma^{(Q)}$ with $U(1)$ charge Q , the covariant constraints $\bar{D}_+\Gamma^{(Q)} = E$ and $\bar{D}_+E^{(Q)} = 0$ can be solved by taking $\Gamma = e^{-Q\mathcal{A}}\bar{\Gamma}^{(Q)}$ and $E = e^{-Q\mathcal{A}}\bar{E}^{(Q)}$. The kinetic terms for the $\mathcal{N} = (0, 2)$ Fermi multiplet are given by

$$\begin{aligned} S_{\text{ferm}}^{(0,2)} &= -\frac{1}{2} \int d^2x d^2\theta \bar{\Gamma}\Gamma \\ &= \int d^2x \left[i\bar{\chi}_-(D_0 + D_1)\chi_- + |G|^2 - |E^{(Q)}(\phi)|^2 - \bar{\chi}_-\frac{\partial E^{(Q)}(\phi)}{\partial\phi^i}\psi_{+i} + \bar{\psi}_{+i}\frac{\partial\bar{E}^{(Q)}(\bar{\phi})}{\partial\bar{\phi}^i}\chi_- \right]. \end{aligned} \quad (2.20)$$

We see that the holomorphic function $E^{(Q)}(\phi)$ appears as a potential term for chiral multiplet in (2.20), which we call an E -term potential. By definition (2.17), E -term transforms in the same way as the Fermi multiplet Γ .

2.1.3 $\mathcal{N} = (0, 2)$ superpotential

Let $J^a(\Phi)$ be a superpotential which is a holomorphic function of chiral superfields Φ for a set of Fermi multiplets $\{\Gamma^a\}$. Then a supersymmetric action can be also constructed by integrating over half of superspace as

$$\begin{aligned} S_J^{(0,2)} &= -\frac{1}{\sqrt{2}} \int d^2x d\theta^+ \sum_a \Gamma_a J^a(\Phi) \Big|_{\bar{\theta}^+=0} - \text{h.c.} \\ &= -\sum_a \int d^2x \left[G_a J^a(\phi) + \sum_i \chi_{-a} \frac{\partial J^a}{\partial\phi^i} \psi_{+i} \right] - \text{h.c.} \end{aligned} \quad (2.21)$$

By integrating out the auxiliary field G_a , one obtains a potential term $\sim |J^a(\phi)|^2$. We shall call this a J -term potential. It follows from gauge invariance of $\Gamma_a J^a$ that $Q_{\Gamma_a} = -Q_{J^a}$. Thus J -term transforms in the conjugate representation, namely as $\tilde{\Gamma}$. The bosonic potential terms specified by holomorphic functions $E(\phi)_a$ and $J^a(\phi)$ are associated to the Fermi multiplet Γ_a . It is important to note that in $\mathcal{N} = (0, 2)$ theories, there is a symmetry between Fermi multiplet Γ and its conjugate $\tilde{\Gamma}$ under an exchange of E - and J -terms.

Since $\mathcal{N} = (0, 2)$ Fermi multiplet Γ_a is not a genuine chiral superfield obeying $\bar{D}_+ \Gamma = \sqrt{2}E$, one needs to impose the condition

$$E \cdot J = \sum_a E_a J^a = 0 \quad (2.22)$$

to ensure that the J -term potential $\Gamma_a J^a(\Phi)$ is chiral, i.e. $\bar{D}_+(\Gamma_a J^a) = 0$.

It is important to note that as 3d $\mathcal{N} = 2$ supersymmetric theories with a superpotential $W_{3d}(\Phi)$ admits $\mathcal{N} = (0, 2)$ supersymmetric boundary conditions with $W(\Phi)$ being constant [22], the condition (2.22) can be relaxed so that

$$E \cdot J = W_{3d}(\Phi) \quad (2.23)$$

if $\mathcal{N} = (0, 2)$ theories live on a boundary of 3d $\mathcal{N} = 2$ theories [23, 24]. This is a 3d analogue of the Warner problem [25] so that (2.23) exhibits holomorphic factorization of 3d bulk superpotential.

One simple example of the superpotential is an FI and θ term

$$\begin{aligned} S_{\text{FI}} &= \frac{t}{4} \text{Tr} \int d^2x d\theta^+ \Upsilon \Big|_{\bar{\theta}^+ = 0} + \text{h.c.} \\ &= \text{Tr} \int d^2x \left[-rD + \frac{\theta}{2\pi} F_{01} \right] \end{aligned} \quad (2.24)$$

where $t = ir + \frac{\theta}{2\pi}$ is a complex combination of a FI parameter r and θ angle.

In total, there are three contributions to potential energy, i.e. D -, E - and J -terms. $\mathcal{N} = (0, 2)$ gauge theories are expected to flow in the IR to the non-linear sigma model whose target space is determined by the vanishing D -, E - and J -terms.

2.2 $\mathcal{N} = (0, 4)$ supersymmetric theories

Let us discuss the $\mathcal{N} = (0, 4)$ supersymmetric gauge theories. There are four kinds of supermultiplets; vector multiplets, hypermultiplets, twisted hypermultiplets and Fermi multiplets. We construct them by using $\mathcal{N} = (0, 2)$ supermultiplets which have an enhanced $SO(4) \cong SU(2)_C \times SU(2)_H$ R-symmetry of $\mathcal{N} = (0, 4)$ supersymmetry.

2.2.1 $\mathcal{N} = (0, 4)$ vector multiplets

The $\mathcal{N} = (0, 4)$ vector multiplet V consist of an $\mathcal{N} = (0, 2)$ vector multiplet Υ and an adjoint-valued $\mathcal{N} = (0, 2)$ Fermi multiplet Γ

$$V = (\Upsilon, \Gamma). \quad (2.25)$$

In components it contains a gauge field, a pair of left-moving complex fermions $\lambda_{\underline{A}}^{\bar{A}}$ which transform as $(\mathbf{2}, \mathbf{2})_-$ under the $SU(2)_C \times SU(2)_H$ R-symmetry and auxiliary fields transforming as $(\mathbf{1}, \mathbf{3})$. The

$\mathcal{N} = (0, 4)$ vector multiplet does not contain scalar fields, hence there is no Coulomb branch. The adjoint-valued $\mathcal{N} = (0, 2)$ Fermi multiplet Γ obeys

$$\overline{D}_+ \Gamma = E_\Gamma \quad (2.26)$$

where E_Γ is a holomorphic function of chiral superfields which transforms in the adjoint representation of the gauge group. It can be expressed as (2.30) in terms of chiral fields of $\mathcal{N} = (0, 4)$ twisted hypermultiplets.

2.2.2 $\mathcal{N} = (0, 4)$ hypermultiplets

The $\mathcal{N} = (0, 4)$ hypermultiplet consists of a pair of $\mathcal{N} = (0, 2)$ chiral multiplets L and R which transform in conjugate representations of the gauge group

$$H = (R, L). \quad (2.27)$$

Under the R-symmetry $SU(2)_C \times SU(2)_H$ the chiral field and the anti chiral field transform in the $(\mathbf{1}, \mathbf{2})$ and the right-moving fermions transform as $(\mathbf{2}, \mathbf{1})_+$. The kinetic terms for $\mathcal{N} = (0, 4)$ hypermultiplet are a sum of those for $\mathcal{N} = (0, 2)$ chiral multiplets given in (2.16). In addition, $\mathcal{N} = (0, 4)$ hypermultiplet can couple to $\mathcal{N} = (0, 4)$ vector multiplet through the $\mathcal{N} = (0, 2)$ Fermi multiplet Γ as a J -type potential [15]

$$J^\Gamma = RL. \quad (2.28)$$

2.2.3 $\mathcal{N} = (0, 4)$ twisted hypermultiplets

In a similar fashion as in $\mathcal{N} = (0, 4)$ hypermultiplet, $\mathcal{N} = (0, 4)$ twisted hypermultiplet consists of a pair of $\mathcal{N} = (0, 2)$ chiral multiplets U and D transforming in conjugate representations under the gauge group

$$T = (U, D). \quad (2.29)$$

In contrast to the hypermultiplet, a pair of complex scalars transform as $(\mathbf{2}, \mathbf{1})$ and the right-moving fermions transform as $(\mathbf{1}, \mathbf{2})_+$ under the R-symmetry $SU(2)_C \times SU(2)_H$. Again the kinetic terms for $\mathcal{N} = (0, 4)$ twisted hypermultiplet are given by a sum of (2.16) for both U and D . The $\mathcal{N} = (0, 4)$ twisted hypermultiplet can couple to a vector multiplet via the E -term potential (2.30).

It is important to note that the condition (2.22) cannot be satisfied if a single $\mathcal{N} = (0, 4)$ vector multiplet is coupled to both $\mathcal{N} = (0, 4)$ hypermultiplet and $\mathcal{N} = (0, 4)$ twisted hypermultiplet since $E_\Gamma J^\Gamma = \text{Tr} U D R L \neq 0$. This can be solved by introducing $\mathcal{N} = (0, 4)$ Fermi multiplets which couple to both the $\mathcal{N} = (0, 4)$ hypermultiplet and the twisted hypermultiplet.

Since the $\mathcal{N} = (4, 4)$ vector multiplet decomposes into $\mathcal{N} = (0, 4)$ vector multiplet and adjoint valued $\mathcal{N} = (0, 4)$ twisted hypermultiplet, E_Γ in (2.26) can be expressed as a holomorphic function of adjoint valued chiral multiplets U and D which constitute the $\mathcal{N} = (0, 4)$ twisted hypermultiplet [15]:

$$E_\Gamma = UD. \quad (2.30)$$

2.2.4 $\mathcal{N} = (0, 4)$ Fermi multiplets

The $\mathcal{N} = (0, 4)$ Fermi multiplet Ξ consists of a pair of $\mathcal{N} = (0, 2)$ Fermi multiplets Γ and Γ'

$$\Xi = (\Gamma, \Gamma'). \quad (2.31)$$

A pair of left-moving fermions ξ_- and $\tilde{\xi}$ in the multiplet transform as $(\mathbf{1}, \mathbf{1})_-$ under the $SU(2)_C \times SU(2)_H$ R-symmetry.

Although they are trivial under the R-symmetry, they play a key role in defining consistent $\mathcal{N} = (0, 4)$ gauge theories. As discussed in 2.2.3, when both $\mathcal{N} = (0, 4)$ hyper and twisted hypermultiplets couple to a gauge field, it is required to introduce neutral Fermi multiplet so that the supersymmetric condition (2.22) is satisfied. The simplest situation would be the case with one hyper multiplet and one twisted hyper multiplet. In addition, as we discuss in section 2.2.5, when there are enough hyper and twisted hypermultiplets in the gauge theory, the charged Fermi multiplets are required to cancel a gauge anomaly.

2.2.5 Anomaly

$\mathcal{N} = (0, 4)$ supersymmetric gauge theory can be anomalous because left- and right-moving fermions are not necessarily paired together.

Let G be a simple compact group of which a system of right- and left-handed chiral fermions transform under a unitary representation R through coupling to a (background) gauge field whose field strength is \mathbf{f} . We define the quadratic index $C(R)$ of R as a sum of length-squared of weights λ

$$C(R) = \frac{1}{\text{rank}G} \sum_{\lambda \in R} \|\lambda\|^2 \quad (2.32)$$

where $\|\alpha\|^2 = 2$ for long roots α . This is normalized so that $C(\text{adjoint}) = 2h$ where h is the dual Coxeter number.

The contribution to anomaly the 4-form is summarized as follows:

2d $\mathcal{N} = (0, 2)$ multiplet	R	\mathbf{f}^2
chiral Φ	\square or $\bar{\square}$	$-C(R)$
	adjoint	$-2h$
Fermi Γ	\square or $\bar{\square}$	$C(R)$
	adjoint	$2h$
gauge Υ	adjoint	$2h$

(2.33)

The left- and right-moving fermions have the opposite contributions to the anomaly whereas the fundamental and anti-fundamental representations have the same contributions. For $SU(N)$ we have $C(\square) = 1$ and $C(\text{adjoint}) = 2h = 2N$ and the anomaly contributions are summarized as

2d $\mathcal{N} = (0, 2)$ multiplet	R	$\mathbf{f}_{\text{su}(N)}^2$
chiral Φ	\square or $\bar{\square}$	-1
	adjoint	$-2N$
Fermi Γ	\square or $\bar{\square}$	1
	adjoint	$2N$
gauge Υ	adjoint	$2N$

(2.34)

In particular, the gauge anomaly is required to be cancelled for a consistent quantum field theory, which leads to an important constraint. Unlike the gauge anomaly, the global anomaly may remain in the theory. If the global anomaly remains in the IR, the current of the global symmetry of Lie algebra \mathfrak{h} can be holomorphic or anti-holomorphic, i.e. left- or right-moving. Then the corresponding global symmetry can be enhanced to the affine Lie algebra $\widehat{\mathfrak{h}}$ of level $|2\mathcal{A}_{\mathfrak{h}}|$ where $\mathcal{A}_{\mathfrak{h}}$ is the anomaly coefficient. The affine Lie algebra $\widehat{\mathfrak{h}}$ acts in the holomorphic or anti-holomorphic sector of the associated CFT depending on the sign of the anomaly coefficient $\mathcal{A}_{\mathfrak{h}}$.

3 $\mathcal{N} = (0, 4)$ boundary conditions

3.1 Brane construction

We consider Type IIB superstring theory in Minkowski spacetime with time coordinate x^0 and space coordinates x^1, \dots, x^9 [17]. Let \mathcal{Q}_L and \mathcal{Q}_R be the supercharges generated by left- and right-moving world-sheet degrees of freedom. They satisfy the chirality conditions of Type IIB superstring theory: $\bar{\Gamma}\mathcal{Q}_L = \mathcal{Q}_L$, $\bar{\Gamma}\mathcal{Q}_R = \mathcal{Q}_R$ where $\bar{\Gamma} = \Gamma_0 \cdots \Gamma_9$.

We introduce NS5-branes with world-volumes in $(x^0, x^1, x^2, x^3, x^4, x^5)$ directions, D5-branes with world-volumes in $(x^0, x^1, x^2, x^7, x^8, x^9)$ directions, NS5'-branes with world-volumes in $(x^0, x^1, x^6, x^7, x^8, x^9)$ directions, D5'-branes with world-volumes in $(x^0, x^1, x^3, x^4, x^5, x^6)$ directions, and D3-branes in (x^0, x^1, x^2, x^6) directions:

	0	1	2	3	4	5	6	7	8	9
D3	o	o	o	–	–	–	o	–	–	–
NS5	o	o	o	o	o	o	–	–	–	–
D5	o	o	o	–	–	–	–	o	o	o
NS5'	o	o	–	–	–	–	o	o	o	o
D5'	o	o	–	o	o	o	o	–	–	–

(3.1)

All the branes share the (x^0, x^1) directions. We consider the case in which the D3-branes are bounded by all the 5-branes in the (x^2, x^6) directions. According to the Kaluza-Klein reduction in these two directions, the world-volume theories on the D3-branes therefore are macroscopically two dimensional.

The presence of all branes breaks down the space-time $SO(1, 9)$ Lorentz symmetry to $SO(1, 1)_{01} \times SO(3)_{345} \times SO(3)'_{789}$ where $SO(1, 1)$ acts on x^0, x^1 , $SO(3)_{345}$ acts on x^3, x^4, x^5 and $SO(3)'_{789}$ acts on x^7, x^8, x^9 . The brane configuration (3.1) preserves linear combinations of supercharges $\epsilon_L \mathcal{Q}_L + \epsilon_R \mathcal{Q}_R$ with ϵ_L and ϵ_R being spinors such that

$$\Gamma_{012345}\epsilon_L = \epsilon_L, \quad \Gamma_{012345}\epsilon_R = -\epsilon_R, \quad (3.2)$$

$$\Gamma_{012789}\epsilon_R = \epsilon_L \quad (3.3)$$

$$\Gamma_{016789}\epsilon_L = \epsilon_L, \quad \Gamma_{016789}\epsilon_R = -\epsilon_R, \quad (3.4)$$

$$\Gamma_{013456}\epsilon_R = \epsilon_L, \quad (3.5)$$

$$\Gamma_{0126}\epsilon_R = \epsilon_L. \quad (3.6)$$

These conditions give rise to three non-trivial projection conditions so that the presence of branes breaks supersymmetry to 1/8 of the original supersymmetry and four supercharges are preserved. Besides, these conditions lead to $\Gamma_{01}\epsilon_L = \epsilon_L$, $\Gamma_{01}\epsilon_R = \epsilon_R$, which implies that chiral $\mathcal{N} = (0, 4)$ supersymmetry exists in the (x^0, x^1) directions and thereby $SO(3)_{345} \times SO(3)'_{789}$ is identified with the $SO(4)_R \cong SU(2)_C \times SU(2)_H$ R-symmetry of the $\mathcal{N} = (0, 4)$ supersymmetry.

3.2 $\mathcal{N} = (0, 4)$ boundary conditions

When the D3-branes are finite only in x^6 direction and are semi-infinite in the region $x^2 \geq 0$, the configuration of D3-, NS5- and D5-branes leads to 3d $\mathcal{N} = 4$ supersymmetric field theories and two extra 5-branes, NS5'- and D5'-branes break further half of supersymmetry to give rise to $\mathcal{N} = (0, 4)$ boundary conditions at $x^2 = 0$ in these theories [16].

3.2.1 3d $\mathcal{N} = 4$ vector multiplet

When a D3-brane is stretched between two parallel NS5-branes along x^6 direction, the low-energy effective theory is that of 3d $\mathcal{N} = 4$ Abelian vector multiplet. It contains a three-dimensional gauge fields A_μ , $\mu = 0, 1, 2$, three real scalar fields ϕ^i , $i = 3, 4, 5$ which transforming as $(\mathbf{3}, \mathbf{1})$ of $SU(2)_C \times SU(2)_H$, an auxiliary field D and a fermionic fields λ . The irreducible 3d $\mathcal{N} = 4$ vector multiplet \mathbb{V} decomposes into a sum of $\mathcal{N} = (0, 4)$ vector multiplet V and $\mathcal{N} = (0, 4)$ twisted hypermultiplet T :

$$\mathbb{V} = (V, T). \quad (3.7)$$

1. NS5' and $(0, 4)$ vector multiplet

When the D3-brane further ends on an NS5'-brane, it fixes the motion of the D3-brane in (x^3, x^4, x^5) while the two-dimensional gauge field A_α , $\alpha = 0, 1$ is free to fluctuate and normal component A_2 of gauge field obeys the Dirichlet boundary condition. Correspondingly, the field theory admits the half BPS boundary conditions

$$F_{2\alpha}|_\partial = 0, \quad D_\alpha \phi^i|_\partial = 0, \quad (3.8)$$

along with the massless left-moving fermions. The boundary massless modes which are two-dimensional gauge fields A_α and the left-moving fermions form the irreducible $\mathcal{N} = (0, 4)$ vector multiplet. Therefore the NS5'-brane allows boundary conditions in which $(0, 4)$ vector multiplet V on the boundary is free while $\mathcal{N} = (0, 4)$ twisted hypermultiplet T vanishes.

2. D5' and $(0, 4)$ twisted hypermultiplet

Conversely, when the D3-brane terminates on a D5'-brane, the three scalar fields ϕ^i are free to fluctuate as the D5'-brane spans in the (x^3, x^4, x^5) directions. On the other hand, the gauge field A_α satisfies the Dirichlet boundary condition and the scalar field A_2 is free to move at the boundary. In field theory analysis this corresponds to the half of BPS boundary conditions in 3d $\mathcal{N} = 4$ Abelian vector multiplet

$$F_{\alpha\beta}|_\partial = 0, \quad D_2 \phi^i|_\partial = 0, \quad (3.9)$$

when the massless right-moving fermions survive at the boundary. The three scalar fields ϕ^i and the scalar field A_2 can form a pair of complex scalars transforming as $(\mathbf{2}, \mathbf{1})$. They eventually combine with the right-moving fermions into $\mathcal{N} = (0, 4)$ twisted hypermultiplet. Hence the D5'-brane sets $\mathcal{N} = (0, 4)$ vector multiplet V to zero and leaves $\mathcal{N} = (0, 4)$ twisted hypermultiplet T at the boundary.

When N_c D3-branes end on a D5'-brane, the half BPS boundary conditions are generalized to the Nahm pole boundary condition [16]:

$$F_{\alpha\beta}|_\partial = 0, \quad D_2 \phi^i|_\partial = \epsilon^{ijk} [\phi^j, \phi^k]|_\partial. \quad (3.10)$$

The pole governed by the Nahm equation would describe the D3-branes which polarize into a fuzzy funnel configuration [26, 27].

3.2.2 3d $\mathcal{N} = 4$ hypermultiplet

The dynamics of a D3-brane ending on two parallel D5-branes would be described by a theory of 3d $\mathcal{N} = 4$ hypermultiplet. The bosonic massless modes in the theory are the fluctuations of the

D3-brane in the (x^7, x^8, x^9) directions and the scalar field A_6 . The three real scalar fields transform as $(\mathbf{1}, \mathbf{3})$ under the $SU(2)_C \times SU(2)_H$ R-symmetry while the scalar field A_6 transform as $(\mathbf{1}, \mathbf{1})$. The irreducible 3d $\mathcal{N} = 4$ hypermultiplet \mathbb{H} decomposes as the sum of $\mathcal{N} = (0, 4)$ hypermultiplet H and $\mathcal{N} = (0, 4)$ Fermi multiplet Ξ :

$$\mathbb{H} = (H, \Xi). \quad (3.11)$$

1. NS5' and $(0, 4)$ hypermultiplet

When the D3-brane terminating on two D5-branes further ends on an NS5'-brane, the three scalar fields describing the fluctuations in the (x^7, x^8, x^9) directions and the scalar field A_6 still remain. The corresponding half BPS boundary conditions in 3d $\mathcal{N} = 4$ hypermultiplet can be found in field theory analysis

$$\partial_2 q|_{\partial} = 0, \quad \partial_2 \tilde{q}|_{\partial} = 0, \quad (3.12)$$

when the massless right-moving fermions are left at the boundary. The pair of complex scalar fields and the right-moving fermions form $\mathcal{N} = (0, 4)$ hypermultiplet. Thus the NS5'-brane keeps $\mathcal{N} = (0, 4)$ hypermultiplet H and sets $\mathcal{N} = (0, 4)$ Fermi multiplet Ξ to zero.

2. D5' and $(0, 4)$ Fermi multiplet

When the D3-brane between the two D5-branes further attach on an D5'-brane, all the bosonic massless modes are set to zero. These boundary conditions correspond to the half of BPS boundary conditions in 3d $\mathcal{N} = 4$ hypermultiplet

$$\partial_\alpha q|_{\partial} = 0, \quad \partial_\alpha \tilde{q}|_{\partial} = 0, \quad (3.13)$$

when the massless left-moving fermions are kept at the boundary. The left-moving fermions without any bosonic degrees of freedom consistently form $\mathcal{N} = (0, 4)$ Fermi multiplet. So the D5'-brane kills $\mathcal{N} = (0, 4)$ hypermultiplet H and leaves $\mathcal{N} = (0, 4)$ Fermi multiplet Ξ .

Altogether there are four types of boundary conditions which correspond to the four types of junctions of branes; D3-NS-NS', D3-NS-D5', D3-D5-NS' and D3-D5-D5'. These intersections respectively admit boundary local operators which are involved in $\mathcal{N} = (0, 4)$ vector, twisted hyper, hyper and Fermi multiplets.

3.3 Boundary anomaly and linking number

When we consider chiral supersymmetric boundary conditions in 3d supersymmetric gauge theory, there also exists an anomaly contribution from bulk fields. It is argued in the analysis [24] of $(0, 2)$ boundary conditions for 3d $\mathcal{N} = 2$ theory, that the bulk fields may have half of the contributions as those from boundary fields. For $SU(N)$ the anomaly contribution is given by

3d $\mathcal{N} = 2$ multiplet with 1/2 BPS b.c.	R	$\mathbf{f}_{su(N)}^2$
chiral multiplet with N b.c.	\square or $\overline{\square}$	$-\frac{1}{2}$
	adjoint	$-N$
chiral multiplet with D b.c.	\square or $\overline{\square}$	$\frac{1}{2}$
	adjoint	N
gauge multiplet with \mathcal{N} b.c.	adjoint	N
gauge multiplet with \mathcal{D} b.c.	adjoint	$-N$

(3.14)

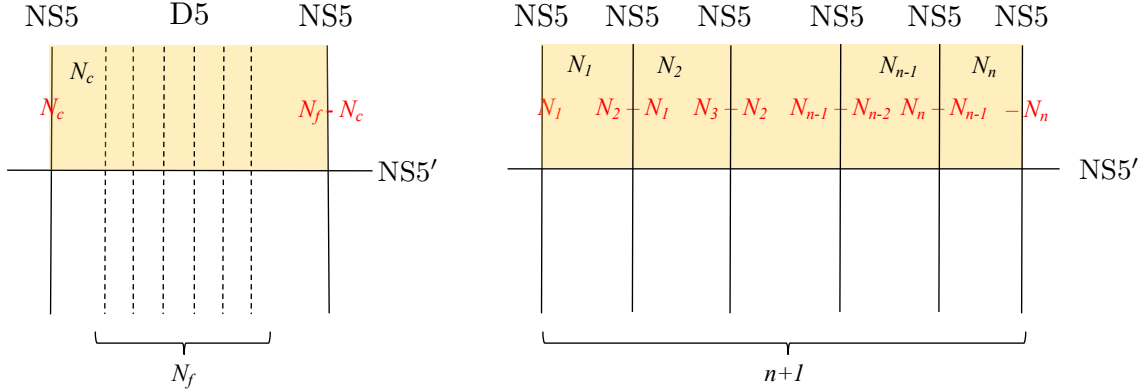

Figure 1: Brane construction of 3d $\mathcal{N} = 4$ $U(N_c)$ gauge theory with N_f hypermultiplets and that of 3d $\mathcal{N} = 4$ $\prod_{i=1}^n U(N_i)$ linear quiver gauge theory with bi-fundamental hypermultiplets. The numbers with red color indicate the linking numbers.

where N, D b.c. stand for the Neumann and Dirichlet boundary condition for 3d $\mathcal{N} = 2$ chiral multiplet scalar fields and \mathcal{N}, \mathcal{D} b.c. imply the Neumann and Dirichlet boundary conditions for 3d gauge field.

As discussed in section 2.2.5, gauge anomaly needs to be cancelled. Otherwise, the Neumann boundary condition for gauge field is not consistent. For example, the boundary gauge anomaly polynomial for 3d $\mathcal{N} = 4$ $U(N_c)$ gauge theory with N_f fundamental hypermultiplets obeying (\mathcal{N}, N) boundary condition is given by

$$\mathcal{I}_{(\mathcal{N}, N)}^{(N_c) - [N_f]} = -(N_f - 2N_c) \text{Tr}(\mathfrak{s}^2) \quad (3.15)$$

where \mathfrak{s} is the field strength of $U(N)$ gauge field. The boundary anomaly polynomial for 3d $\mathcal{N} = 4$ $\prod_i^n U(N_i)$ linear quiver gauge theory with bi-fundamental hypermultiplets obeying (\mathcal{N}, N) boundary conditions is

$$\mathcal{I}_{(\mathcal{N}, N)}^{(N_1) - (N_2) - \dots - (N_n)} = (-N_2 + 2N_1) \text{Tr}(\mathfrak{s}_1^2) + \sum_{i=2}^{n-1} (2N_i - N_{i-1} - N_{i+1}) \text{Tr}(\mathfrak{s}_i^2) + (-N_{n-1} + 2N_n) \text{Tr}(\mathfrak{s}_n^2) \quad (3.16)$$

where \mathfrak{s}_i is the field strength of $U(N_i)$ gauge field.

As shown in Figure 1, the 3d $\mathcal{N} = 4$ $U(N_c)$ gauge theory with N_f hypers can be constructed as a world-volume theory of stack of N_c D3-branes intersecting with N_f D5-branes stretched between two NS5-branes. Also the 3d $\mathcal{N} = 4$ $\prod_{i=1}^n U(N_i)$ linear quiver gauge theory with bi-fundamental hypermultiplets can be realized as n sets of N_i D3-branes suspended between $(n + 1)$ NS5-branes. We observe that

the boundary non-Abelian gauge anomaly coefficient is encoded as the difference of linking numbers of the corresponding right and left NS5-branes.

The gauge anomaly cancellation can be achieved by introducing two-dimensional boundary degrees of freedom which are charged under the gauge symmetry. It can be seen that this is naturally achieved by considering consistent linking number of boundary NS5'-branes and making use of our identification of matter multiplets in brane box configuration.

3.4 Brane box configuration

Furthermore, we introduce several NS5- and NS5'-branes which bound the D3-branes at a finite distance in both x^6 and x^2 directions. This configuration leads to two-dimensional $\mathcal{N} = (0, 4)$ quiver gauge theory in which each box of N D3-branes defines $U(N)$ gauge symmetry factor. The gauge coupling of the gauge theory is given by

$$\frac{1}{e^2} = \frac{\Delta x^2 \Delta x^6}{g_s} \quad (3.17)$$

where g_s is the string coupling. Δx^6 and Δx^2 are the distance of two NS5-branes along x^6 and that of two NS5'-branes along x^2 . We call this brane box model. In the following section, we study the resulting $\mathcal{N} = (0, 4)$ quiver gauge theory by identifying the matter content and interactions.

4 D1-D5-KK system

Now we would like to study $\mathcal{N} = (0, 4)$ quiver gauge theory which is constructed from a periodic array of D3-branes in (x^2, x^6) plane. In this section we analyze the spectrum of brane tiling model by taking the T-dual configuration [28].

The T-duality along x^6 turns the k NS5-branes into k Kaluza-Klein (KK) monopoles which can be described by a multi-centered Taub-NUT metric with non-trivial geometry along the directions (x^6, x^7, x^8, x^9) where x^6 is the T-dual coordinate of x^6 . Since the original k NS5-branes coincide in the directions (x^7, x^8, x^9) , the centers of the corresponding k KK monopoles also coincide. This means that the geometry contains A_{k-1} singularities. Also the T-duality along x^6 translates the D3-branes, D5-branes and D5'-branes into D2-branes, D6-branes and the D4'-branes respectively.

Similarly the T-duality along x^2 directions translates the k' NS5'-branes into the k' KK monopoles extending along $(x^0, x^1, x^6, x^7, x^8, x^9)$ with non-trivial geometry along (x^2, x^3, x^4, x^5) . Again since the centers of KK monopoles coincide, the space-time contains $A_{k'-1}$ singularities. Under the T-duality along x^2 , the D2-branes, D6-branes and D4'-branes turn into D1-branes, D5-branes and D5'-branes respectively. Consequently the T-dual configuration is the D1-D5-KK system:

	0	1	2'	3	4	5	6'	7	8	9
D1	○	○	—	—	—	—	—	—	—	—
KK	○	○	○	○	○	○	—	—	—	—
D5	○	○	—	—	—	—	○	○	○	○
KK'	○	○	—	—	—	—	○	○	○	○
D5'	○	○	○	○	○	○	—	—	—	—

(4.1)

Before orbifolding, the configuration (4.1) is invariant under the space-time symmetry $SO(1, 1)_{0,1} \times SO(4)_{2'345} \times SO(4)_{6'789}$. Let (\tilde{A}, \tilde{A}') and (A, A') represent the $\mathbf{2}$'s of the $SU(2)_C \times SU(2)'_C \cong SO(4)_{2'345}$ and those of the $SU(2)_H \times SU(2)'_H \cong SO(4)_{6'789}$. Here the $SU(2)_C \times SU(2)_H$ is the R-symmetry group in the $\mathcal{N} = (0, 4)$ gauge theories in such a way that $SU(2)_C$ rotates the twisted hypermultiplet scalars while the $SU(2)_H$ rotates the hypermultiplet scalars.

4.1 D1-branes on $\mathbb{C}^2/\mathbb{Z}_k \times \mathbb{C}^2/\mathbb{Z}_{k'}$

4.1.1 $\mathcal{N} = (0, 2)$ quiver

Let us firstly consider the configuration in which D1-branes probing $\mathbb{C}^2/\mathbb{Z}_k \times \mathbb{C}^2/\mathbb{Z}_{k'}$. This corresponds to the T-dual D3-brane box model where neither D5- nor D5'-branes exist. Generically the

two-dimensional low-energy effective world-volume theory would preserve $\mathcal{N} = (0, 4)$ supersymmetry.

To identify the gauge theory on D1-branes at singularity, we start from the N D1-branes over \mathbb{C}^4 and use the technique developed in [29]. The world-volume theory is 2d $\mathcal{N} = (8, 8)$ supersymmetric $U(N)$ gauge theory. In terms of $\mathcal{N} = (0, 2)$ supermultiplets, it consists of $\mathcal{N} = (0, 2)$ gauge multiplet Υ , four $\mathcal{N} = (0, 2)$ adjoint chiral multiplets R , L , U and D , and three $\mathcal{N} = (0, 2)$ adjoint Fermi multiplets Δ , ∇ and Λ . We introduce four complexified coordinates $z_1 = x^{6'} + ix^7$, $z_2 = x^8 + ix^9$, $z_3 = x^{2'} + ix^3$, $z_4 = x^4 + ix^5$. In terms of $\mathcal{N} = (0, 2)$ supermultiplets, J - and E terms are given by

$$\begin{array}{cc}
& J & E \\
\Delta : & L \cdot U - U \cdot L = 0 & D \cdot R - R \cdot D = 0 \\
\nabla : & U \cdot R - R \cdot U = 0 & D \cdot L - L \cdot D = 0 \\
\Lambda : & R \cdot L - L \cdot R = 0 & D \cdot U - U \cdot D = 0.
\end{array} \tag{4.2}$$

Here and in the following \cdot stands for appropriate index contraction which includes gauge and global symmetry groups.

Let us take generators of orbifold group labeled by $(a, k - a, 0, 0)$ and $(0, 0, b, k' - b)$ where $a \leq k$, $b \leq k'$ are positive integers. They act on the complex coordinates as

$$z_1 \mapsto e^{\frac{2\pi ai}{k}} z_1, \quad z_2 \mapsto e^{-\frac{2\pi ai}{k}} z_2, \quad z_3 \mapsto e^{\frac{2\pi bi}{k'}} z_3, \quad z_4 \mapsto e^{-\frac{2\pi bi}{k'}} z_4. \tag{4.3}$$

Since the action of orbifold on the Chan-Paton factor is $\mathcal{R}_{CP} = N(\bigoplus_I \mathcal{R}_I)$ where \mathcal{R}_I is one-dimensional unitary representation of orbifold, the orbifold turns the gauge symmetry group into [18]

$$G = \prod_i U(N)_i = \prod_{i_1=1}^k \prod_{i_2=1}^{k'} U(N)_{i_1, i_2} \tag{4.4}$$

where $i = (i_1, i_2)$, $i_1 = 1, \dots, k$, $i_2 = 1, \dots, k'$ label the gauge nodes. As the chiral multiplets R , L , U and D describe the motions of D1-branes in z_1 , z_2 , z_3 and z_4 respectively, it follows that under the orbifold action (4.3), they are represented as

$$\begin{array}{ll}
R^i_j : & j = i + (a, 0) \qquad \qquad \qquad \text{mod } (k, k') \\
L^i_j : & j = i + (-a, 0) \qquad \qquad \qquad \text{mod } (k, k') \\
U^i_j : & j = i + (0, b) \qquad \qquad \qquad \text{mod } (k, k') \\
D^i_j : & j = i + (0, -b) \qquad \qquad \qquad \text{mod } (k, k').
\end{array} \tag{4.5}$$

According to the form of interaction terms (4.2) and chiral fields (4.5) in the presence of orbifold, three $\mathcal{N} = (0, 2)$ Fermi multiplets transform under the gauge group (4.4) as

$$\begin{array}{ll}
\Delta_{i,j} : & j = i + (a, -b) \qquad \qquad \qquad \text{mod } (k, k') \\
\nabla_{i,j} : & j = i + (-a, -b) \qquad \qquad \qquad \text{mod } (k, k') \\
\Lambda_{i,j} : & j = i \qquad \qquad \qquad \text{mod } (k, k').
\end{array} \tag{4.6}$$

Each of kk' boxes involves four $\mathcal{N} = (0, 2)$ chiral multiplets and three $\mathcal{N} = (0, 2)$ Fermi multiplets so that in total there exist $4kk'$ $\mathcal{N} = (0, 2)$ chiral multiplets and $3kk'$ $\mathcal{N} = (0, 2)$ Fermi multiplets in the quiver gauge theory. The basic building block of the $\mathcal{N} = (0, 4)$ quiver gauge theories in terms of $\mathcal{N} = (0, 2)$ quiver is depicted in Figure 2.

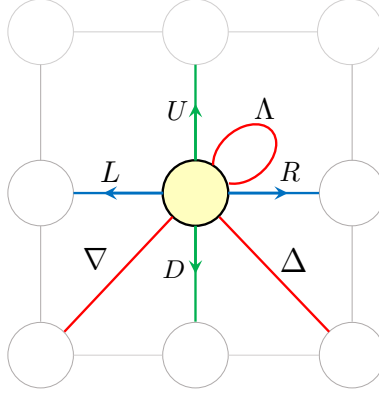

Figure 2: $\mathcal{N} = (0, 2)$ quiver for basic building block of $\mathcal{N} = (0, 4)$ quiver gauge theory. A circular node represents the $\mathcal{N} = (0, 2)$ gauge multiplet. A pair of blue arrows of $\mathcal{N} = (0, 2)$ chiral multiplets (R, L) form $\mathcal{N} = (0, 4)$ hypermultiplet. A pair of green arrows of the chiral multiplets (U, D) form $\mathcal{N} = (0, 4)$ twisted hypermultiplet. Red diagonal lines Δ and ∇ are the $\mathcal{N} = (0, 2)$ Fermi multiplets. A red loop of adjoint $\mathcal{N} = (0, 2)$ Fermi multiplet Λ is involved in $\mathcal{N} = (0, 4)$ vector multiplets.

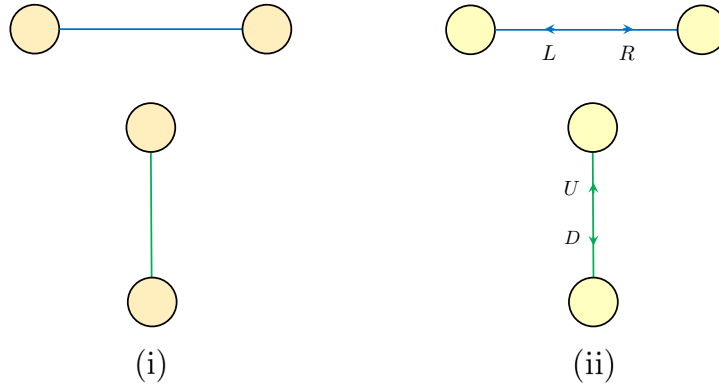

Figure 3: (i) Blue line of $\mathcal{N} = (0, 4)$ hyper and green line of $\mathcal{N} = (0, 4)$ twisted hypermultiplets. (ii) The corresponding pairs of $\mathcal{N} = (0, 2)$ chiral multiplets (R, L) and (U, D) .

4.1.2 $\mathcal{N} = (0, 4)$ quiver

Now we would like to construct $\mathcal{N} = (0, 4)$ quiver. From the discussion in section 2.2, the $\mathcal{N} = (0, 2)$ supermultiplets appearing in $\mathcal{N} = (0, 2)$ quiver of Figure 2 should be promoted to $\mathcal{N} = (0, 4)$ supermultiplets in a consistent way.

The $\mathcal{N} = (0, 2)$ chiral multiplets always appear as a pair of arrows with opposite orientations between adjacent gauge nodes. The pair of $\mathcal{N} = (0, 2)$ chiral multiplets R^i_j and L^i_j corresponding to horizontal arrows will form the bi-fundamental $\mathcal{N} = (0, 4)$ hypermultiplets while the pair of $\mathcal{N} = (0, 2)$ chiral multiplets U^i_j and D^i_j corresponding to vertical arrows will combine into the bi-fundamental $\mathcal{N} = (0, 4)$ twisted hypermultiplets (see Figure 3).

Meanwhile, the three $\mathcal{N} = (0, 2)$ Fermi multiplets split into two types. Two $\mathcal{N} = (0, 2)$ multiplets

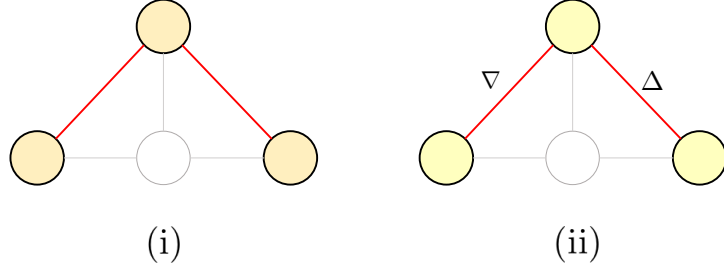

Figure 4: (i) A V-shaped configuration of Fermi multiplet in the $\mathcal{N} = (0, 4)$ quiver diagram. (ii) The corresponding pair of $\mathcal{N} = (0, 2)$ Fermi multiplets (Δ, ∇) in the $\mathcal{N} = (0, 2)$ quiver diagram.

Δ_{ij} and ∇_{ij} represented as diagonal red edges produce the following J - and E -terms:

$$\begin{aligned}
J : & \quad \Delta_{i,i+(a,-b)} \left(L^{i+(a,-b)}_{i+(0,-b)} U^{i+(0,-b)}_i - U^{i+(a,-b)}_{i+(a,0)} L^{i+(a,0)}_i \right), \\
E : & \quad \Delta_{i+(a,-b),i} \left(D^i_{i+(0,-b)} R^{i+(0,-b)}_{i+(a,-b)} - R^i_{i+(a,0)} D^{i+(a,0)}_{i+(a,-b)} \right), \\
J : & \quad \nabla_{i,i-(a,b)} \left(U^{i-(a,b)}_{i-(a,0)} R^{i-(a,0)}_i - R^{i-(a,b)}_{i-(0,b)} U^{i-(0,b)}_i \right), \\
E : & \quad \nabla_{i-(a,b),i} \left(D^i_{i-(0,b)} L^{i-(0,b)}_{i-(a,b)} - L^i_{i-(a,0)} D^{i-(a,0)}_{i-(a,b)} \right). \tag{4.7}
\end{aligned}$$

They give rise to the interaction terms between $\mathcal{N} = (0, 4)$ hypermultiplets and $\mathcal{N} = (0, 4)$ twisted hypermultiplets. Unlike the $\mathcal{N} = (0, 2)$ chiral multiplets, the $\mathcal{N} = (0, 2)$ Fermi multiplets do not appear as a pair of arrows but rather a pair of links forming a V-shaped configuration as shown in Figure 4. We identify them with the *Fermi multiplet* in $\mathcal{N} = (0, 4)$ quiver.

The four types of interactions (4.7) can be easily read from closed loops in quiver diagram. For each of red edges $\Delta_{i,i+(a,-b)}$ and $\nabla_{i,i-(a,b)}$ in the Fermi multiplet, one can draw two triangles sharing the corresponding edge. Given the orientation of the Fermi edge, the triangles lead to two closed loops. If the orientation is directed from i to $i + (a, -b)$ or to $i - (a, b)$, the two loops contribute to J -terms associated to the corresponding Fermi multiplet. If the orientation is opposite, they contribute to the E -terms. Assigning positive and negative signs for clockwise and anti-clockwise loops respectively, we obtain the E - and J -terms (4.7) for $\Delta_{i,i+(a,-b)}$ and $\nabla_{i,i-(a,b)}$ (see Figure 5).

The remaining $\mathcal{N} = (0, 2)$ Fermi multiplets Λ_{ij} sketched as the circular red edges transform as adjoint representation under the corresponding gauge group. They lead to J - and E -terms

$$J : \quad \Lambda_{i,i} \left(R^i_{i+(a,0)} L^{i+(a,0)}_i - L^i_{i+(-a,0)} R^{i+(-a,0)}_i \right), \tag{4.8}$$

$$E : \quad \Lambda_{i,i} \left(D^i_{i+(0,-b)} U^{i+(0,-b)}_i - U^i_{i+(0,b)} D^{i+(0,b)}_i \right). \tag{4.9}$$

The J -terms (4.8) describe the interaction between hypermultiplets while the E -terms (4.9) describe the interaction between twisted hypermultiplets. These Fermi multiplets will combine with the $\mathcal{N} = (0, 2)$ gauge multiplets to form the $\mathcal{N} = (0, 4)$ vector multiplets. We represent the $\mathcal{N} = (0, 4)$ vector multiplet as an orange node (see Figure 6).

Here we can summarize a simple dictionary between the $\mathcal{N} = (0, 2)$ quiver and $\mathcal{N} = (0, 4)$ quiver as follows:

- A circular orange node of $\mathcal{N} = (0, 4)$ vector multiplet consists of $\mathcal{N} = (0, 2)$ gauge node and $\mathcal{N} = (0, 2)$ adjoint Fermi multiplet Λ . The map is shown in Figure 6.

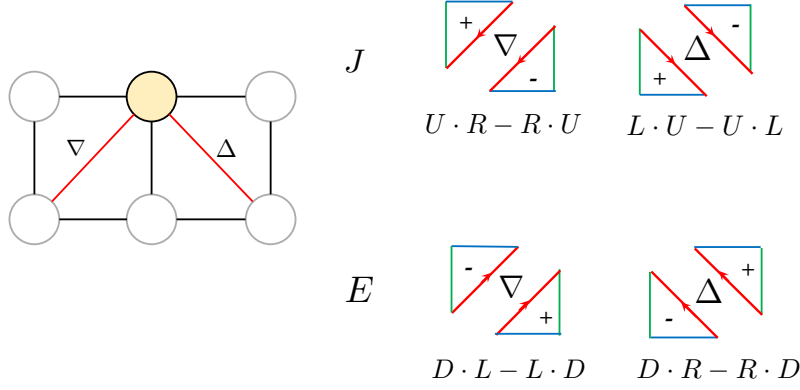

Figure 5: Triangular loops of the E - and J -terms in quiver diagram. The positive and negative signs in the triangles represent the clockwise and anti-clockwise orientations which determine the contributions to the E - and J -terms.



Figure 6: (i) An orange node of vector multiplet in $\mathcal{N} = (0, 4)$ quiver diagram. (ii) The corresponding $\mathcal{N} = (0, 2)$ gauge node and adjoint Fermi multiplet Λ in $\mathcal{N} = (0, 2)$ quiver diagram.

- Blue edge of $\mathcal{N} = (0, 4)$ hyper and green edge of twisted hypermultiplets in $\mathcal{N} = (0, 4)$ quiver diagram translates into pairs of arrows of $\mathcal{N} = (0, 2)$ chiral multiplets (R, L) and (U, D) respectively in $\mathcal{N} = (0, 2)$ quiver diagram. This is shown in Figure 3.
- V-shaped configuration of the Fermi multiplet appears in $\mathcal{N} = (0, 4)$ quiver diagram. This is shown in Figure 4.

It would be instructive to present both $\mathcal{N} = (0, 2)$ quiver and $\mathcal{N} = (0, 4)$ quiver for 2d $\mathcal{N} = (8, 8)$ supersymmetric gauge theory of D1-branes probing \mathbb{C}^4 . They are shown in Figure 7. The $\mathcal{N} = (0, 4)$ quiver contains a single $\mathcal{N} = (0, 4)$ gauge node, a blue line of $\mathcal{N} = (0, 4)$ adjoint hypermultiplet forming a single loop, a green line of $\mathcal{N} = (0, 4)$ adjoint twisted hypermultiplet forming a single loop and a red V-shaped configuration adjoint Fermi multiplet consisting of two loops.

At this stage we can go back to the brane box configuration. For the case of D1-branes probing \mathbb{C}^4 , the T-dual configuration is a periodic single box of D3-branes as shown in Figure 7. It is now easy to read off the field content in the D3-brane box model. Gauge nodes correspond to a boxes of D3-branes. To each of gauge nodes there are bivalent blue links as a pair of edges of $\mathcal{N} = (0, 4)$ hypermultiplets, bivalent green links of $\mathcal{N} = (0, 4)$ twisted hypermultiplets and a pair of V-shaped configuration of Fermi multiplets.

Let us see further examples in the following.

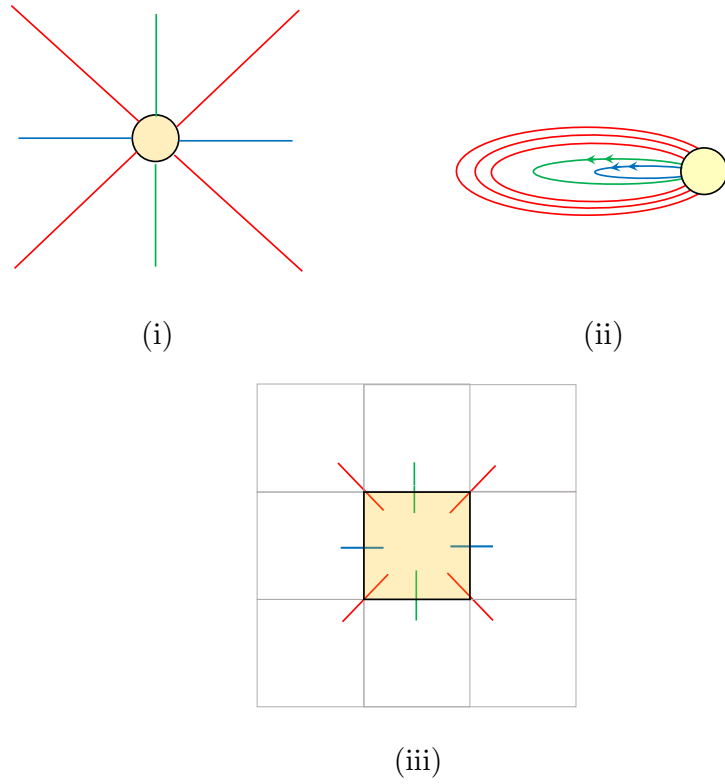

Figure 7: (i) $\mathcal{N} = (0, 4)$ quiver diagram for D1-branes probing \mathbb{C}^4 . (ii) The corresponding $\mathcal{N} = (0, 2)$ quiver. (iii) The T-dual configuration as a single periodic box of D3-branes.

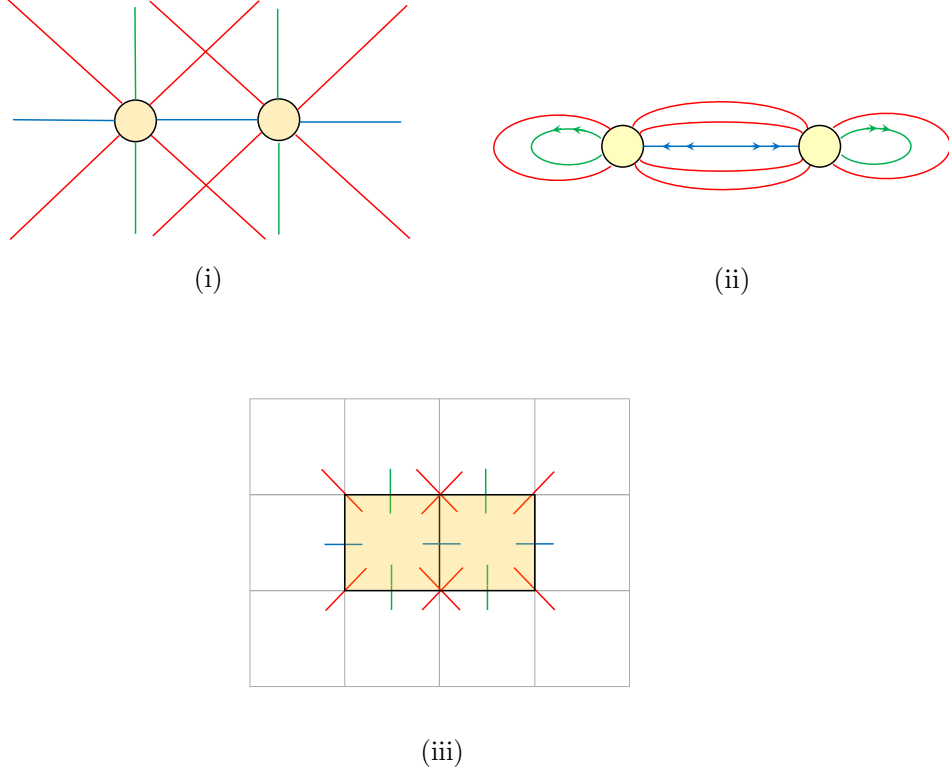

Figure 8: (i) $\mathcal{N} = (0, 4)$ quiver diagram for D1-branes on $\mathbb{C}^2/\mathbb{Z}_2 \times \mathbb{C}^2$. (ii) The corresponding $\mathcal{N} = (0, 2)$ quiver diagram. (iii) D3 brane box configuration which is T-dual to D1-branes on $\mathbb{C}^2/\mathbb{Z}_2 \times \mathbb{C}^2$.

4.1.3 $\mathbb{C}^2/\mathbb{Z}_2 \times \mathbb{C}^2$

In this case the gauge group is $U(N)_{1,0} \times U(N)_{2,0}$. There are eight $\mathcal{N} = (0, 2)$ chiral multiplets

$$\{R^{i_1}_{i_1+1}, L^{i_1}_{i_1-1}, U^{i_1}_{i_1}, D^{i_1}_{i_1}\}_{i_1=1,2}. \quad (4.10)$$

$R^{i_1}_{i_1+1}$ and $L^{i_1}_{i_1-1}$ transform as bi-fundamental representation under the gauge group $U(N)_{1,0} \times U(N)_{2,0}$ and they form two bi-fundamental $\mathcal{N} = (0, 4)$ hypermultiplets: $(R^1_2, L^2_1) \oplus (R^2_1, L^1_2)$. $U^{i_1}_{i_1}$ and $D^{i_1}_{i_1}$ transform as adjoint representation under the gauge group and they combine into two adjoint $\mathcal{N} = (0, 4)$ twisted hypermultiplets: $(U^1_1, D^1_1) \oplus (U^2_2, D^2_2)$.

There are also six $\mathcal{N} = (0, 2)$ Fermi multiplets

$$\{\Delta_{i_1, i_1+1}, \nabla_{i_1, i_1-1}, \Lambda_{i_1, i_1}\}_{i_1=1,2}. \quad (4.11)$$

Δ_{i_1, i_1+1} and ∇_{i_1, i_1-1} transform as bi-fundamental representation under $U(N)_{1,0} \times U(N)_{2,0}$. Λ_{i_1, i_1} are adjoint under $U(N)_{1,0} \times U(N)_{2,0}$ and they combine $\mathcal{N} = (0, 2)$ gauge multiplet to form two $\mathcal{N} = (0, 4)$ vector multiplets.

The theory can be encoded by $\mathcal{N} = (0, 4)$ quiver or $\mathcal{N} = (0, 2)$ quiver diagram shown in Figure 8. The orange node corresponds to $\mathcal{N} = (0, 4)$ vector multiplet for each factor of gauge symmetry groups. The blue lines describe bi-fundamental $\mathcal{N} = (0, 4)$ hypermultiplets and the blue arrows represent R and L forming these $\mathcal{N} = (0, 4)$ hypermultiplets. The green loops represent $\mathcal{N} = (0, 4)$ twisted hypermultiplet consisting of pairs of $\mathcal{N} = (0, 2)$ chiral multiplets U and D . Four red edges between two nodes describe Δ and ∇ while two red loops are adjoint Λ .

In this case $\mathcal{N} = (0, 4)$ supersymmetry is enhanced to $\mathcal{N} = (4, 4)$ in such a way that bi-fundamental $\mathcal{N} = (0, 4)$ hypermultiplets (R, L) and bi-fundamental Fermi multiplets (U, D) further combine into $\mathcal{N} = (4, 4)$ hypermultiplets and adjoint $\mathcal{N} = (0, 4)$ twisted hypermultiplets (U, D) and $\mathcal{N} = (0, 4)$ vector multiplets are promoted to $\mathcal{N} = (4, 4)$ vector multiplets.

The T-dual brane box configuration is shown in Figure 8. This is obtained by the dimensional reduction of the 3d $\mathcal{N} = 4$ quiver gauge theory which has the same gauge group and bi-fundamental hypermultiplets.

4.1.4 $\mathbb{C}^2/\mathbb{Z}_2 \times \mathbb{C}^2/\mathbb{Z}_2$ $(1, 1, 0, 0)$, $(0, 0, 1, 1)$

There are two generators of $\mathbb{C}^2/\mathbb{Z}_2 \times \mathbb{C}^2/\mathbb{Z}_2$ singularity. One of them labeled by $(1, 1, 0, 0)$ acts on the two complex coordinates as $z_1 \mapsto e^{\pi i} z_1$, $z_2 \mapsto e^{\pi i} z_2$ while the other labeled by $(0, 0, 1, 1)$ acts on the others as $z_3 \mapsto e^{\pi i} z_3$, $z_4 \mapsto e^{\pi i} z_4$. The gauge group of the world-volume theory of D1-branes at $\mathbb{C}^2/\mathbb{Z}_2 \times \mathbb{C}^2/\mathbb{Z}_2$ is given by

$$G = \prod_{i_1=1}^2 \prod_{i_2=1}^2 U(N)_{i_1, i_2} \quad (4.12)$$

The matter content consists of sixteen $\mathcal{N} = (0, 2)$ chiral multiplets

$$\{R^i_{i+(1,0)}, L^i_{i+(-1,0)}, U^i_{i+(0,1)}, D^i_{i+(0,-1)}\} \quad (4.13)$$

and twelve $\mathcal{N} = (0, 2)$ Fermi multiplets

$$\{\Delta_{i,i-(1,1)}, \nabla_{i,i-(1,1)}, \Lambda_{i,i}\}. \quad (4.14)$$

where $i = (i_1, i_2)$ are pairs of modulo 2 gauge indices with $i_1 = 1, 2$ and $i_2 = 1, 2$. The quiver diagram is shown in Figure 9.

The blue and green arrows describe bi-fundamental $\mathcal{N} = (0, 4)$ hyper and twisted hypermultiplets respectively. The red lines correspond to bi-fundamental Fermi multiplets while the red loop $\mathcal{N} = (0, 2)$ Fermi multiplets combine with $\mathcal{N} = (0, 2)$ gauge multiplets into $\mathcal{N} = (0, 4)$ vector multiplets.

There are twelve pairs of vanishing J - and E -terms

	J		E
$\Delta_{(1,1)(2,2)}$	$L^{(2,2)}_{(1,2)} U^{(1,2)}_{(1,1)} - U^{(2,2)}_{(2,1)} L^{(2,1)}_{(1,1)} = 0$	$D^{(1,1)}_{(1,2)} R^{(1,2)}_{(2,2)} - R^{(1,1)}_{(2,1)} D^{(2,1)}_{(2,2)} = 0$	
$\Delta_{(1,2)(2,1)}$	$L^{(2,1)}_{(1,1)} U^{(1,1)}_{(1,2)} - U^{(2,1)}_{(2,2)} L^{(2,2)}_{(1,2)} = 0$	$D^{(1,2)}_{(1,1)} R^{(1,1)}_{(2,1)} - R^{(1,2)}_{(2,2)} D^{(2,2)}_{(2,1)} = 0$	
$\Delta_{(2,1)(1,2)}$	$L^{(1,2)}_{(2,1)} U^{(2,2)}_{(2,1)} - U^{(1,2)}_{(1,1)} L^{(1,1)}_{(2,1)} = 0$	$D^{(2,1)}_{(2,2)} R^{(2,2)}_{(1,2)} - R^{(2,1)}_{(1,1)} D^{(1,1)}_{(1,2)} = 0$	
$\Delta_{(2,2)(1,1)}$	$L^{(2,2)}_{(1,2)} U^{(1,2)}_{(1,1)} - U^{(1,1)}_{(1,2)} L^{(1,2)}_{(2,2)} = 0$	$D^{(2,2)}_{(2,1)} R^{(2,1)}_{(1,1)} - R^{(2,2)}_{(1,2)} D^{(1,2)}_{(1,1)} = 0$	
$\nabla_{(1,1)(2,2)}$	$U^{(2,2)}_{(2,1)} R^{(2,1)}_{(1,1)} - R^{(2,2)}_{(1,2)} U^{(1,2)}_{(1,1)} = 0$	$D^{(1,1)}_{(1,2)} L^{(1,2)}_{(2,2)} - L^{(1,1)}_{(2,1)} D^{(2,1)}_{(2,2)} = 0$	
$\nabla_{(1,2)(2,1)}$	$U^{(2,1)}_{(2,2)} R^{(2,2)}_{(1,2)} - R^{(2,1)}_{(1,1)} U^{(1,1)}_{(1,2)} = 0$	$D^{(1,2)}_{(1,1)} L^{(1,1)}_{(2,1)} - L^{(1,2)}_{(2,2)} D^{(2,2)}_{(2,1)} = 0$	
$\nabla_{(2,1)(1,2)}$	$U^{(1,2)}_{(1,1)} R^{(1,1)}_{(2,1)} - R^{(1,2)}_{(2,2)} U^{(2,2)}_{(2,1)} = 0$	$D^{(2,1)}_{(2,2)} L^{(2,2)}_{(1,2)} - L^{(2,1)}_{(1,1)} D^{(1,1)}_{(1,2)} = 0$	
$\nabla_{(2,2)(1,1)}$	$U^{(1,1)}_{(1,2)} R^{(1,2)}_{(2,2)} - R^{(1,1)}_{(2,1)} U^{(2,1)}_{(2,2)} = 0$	$D^{(2,2)}_{(2,1)} L^{(2,1)}_{(1,1)} - L^{(2,2)}_{(1,2)} D^{(1,2)}_{(1,1)} = 0$	
$\Lambda_{(1,1)(1,1)}$	$R^{(1,1)}_{(2,1)} L^{(2,1)}_{(1,1)} - L^{(1,1)}_{(2,1)} R^{(2,1)}_{(1,2)} = 0$	$D^{(1,1)}_{(1,2)} U^{(1,2)}_{(1,1)} - U^{(1,1)}_{(1,2)} D^{(1,2)}_{(1,1)} = 0$	
$\Lambda_{(1,2)(1,2)}$	$R^{(1,2)}_{(2,2)} L^{(2,2)}_{(2,1)} - L^{(1,2)}_{(2,2)} R^{(2,2)}_{(1,2)} = 0$	$D^{(1,2)}_{(1,1)} U^{(1,1)}_{(1,2)} - U^{(1,2)}_{(1,1)} D^{(1,1)}_{(1,2)} = 0$	
$\Lambda_{(2,1)(2,1)}$	$R^{(2,1)}_{(1,1)} L^{(1,1)}_{(2,1)} - L^{(2,1)}_{(1,1)} R^{(1,1)}_{(2,1)} = 0$	$D^{(2,1)}_{(2,2)} U^{(2,2)}_{(2,1)} - U^{(2,1)}_{(2,2)} D^{(2,2)}_{(2,1)} = 0$	
$\Lambda_{(2,2)(2,2)}$	$R^{(2,2)}_{(1,1)} L^{(1,1)}_{(2,2)} - L^{(2,2)}_{(1,1)} R^{(1,2)}_{(2,2)} = 0$	$D^{(2,2)}_{(2,1)} U^{(2,1)}_{(2,2)} - U^{(2,2)}_{(2,1)} D^{(2,1)}_{(2,2)} = 0$	

The T-dual configuration is 2×2 brane box model illustrated in Figure 9. In this case, two NS5-branes and two NS5'-branes are trivially identified going around x^6 and x^2 directions respectively.

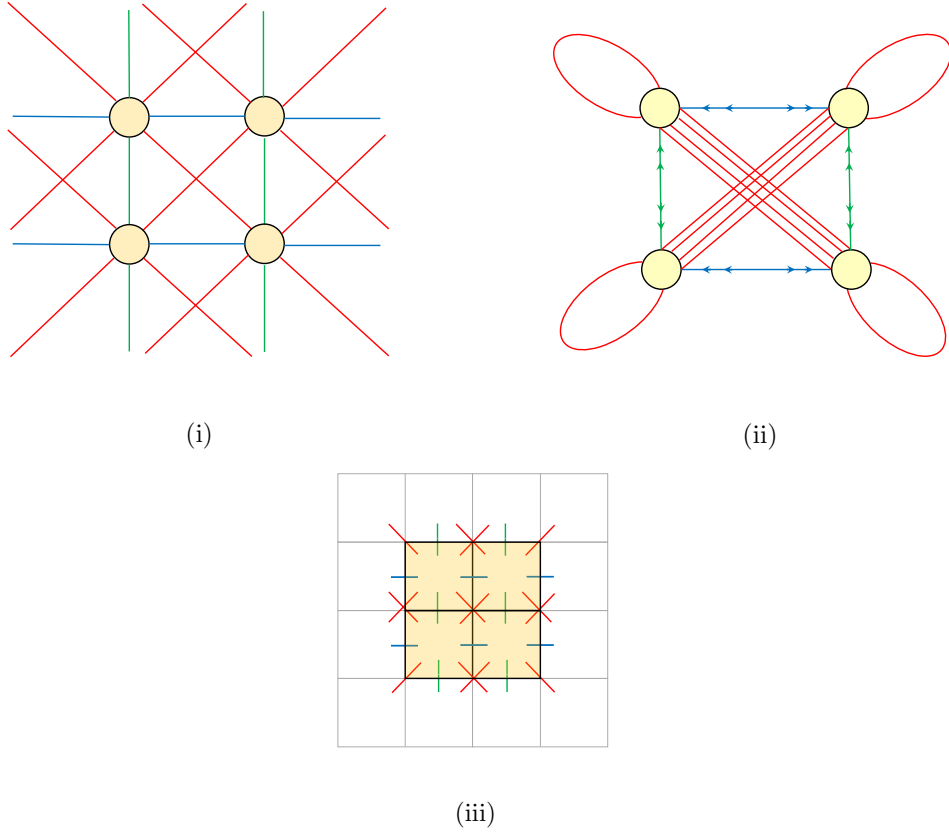

Figure 9: (i) $\mathcal{N} = (0, 4)$ quiver diagram for D1-branes on $\mathbb{C}^2/\mathbb{Z}_2 \times \mathbb{C}^2/\mathbb{Z}_2$. (ii) The corresponding $\mathcal{N} = (0, 2)$ quiver diagram. (iii) D3-brane box configuration which is T-dual to D1-branes on $\mathbb{C}^2/\mathbb{Z}_2 \times \mathbb{C}^2/\mathbb{Z}_2$. Horizontal, vertical and diagonal edges represent hyper, twisted hyper and Fermi multiplets.

4.1.5 $\mathbb{C}^2/\mathbb{Z}_2 \times \mathbb{C}^2/\mathbb{Z}_3$ (1, 1, 0, 0), (0, 0, 1, 2)

The $\mathcal{N} = (0, 4)$ supersymmetric quiver gauge theory of regular N D1-branes on $\mathbb{C}^2/\mathbb{Z}_2 \times \mathbb{C}^2/\mathbb{Z}_3$ has gauge group

$$G = \prod_{i_1=1}^2 \prod_{i_2=1}^3 U(N)_{i_1, i_2}. \quad (4.16)$$

The matter content consists of 24 chiral multiplets

$$\{R^i_{i+(1,0)}, L^i_{i+(-1,0)}, U^i_{i+(0,1)}, D^i_{i+(0,-1)}\} \quad (4.17)$$

and 18 Fermi multiplets

$$\{\Delta_{i,i-(1,1)}, \nabla_{i,i-(1,1)}, \Lambda_{i,i}\}. \quad (4.18)$$

where $i = (i_1, i_2)$ are pairs of gauge indices with $i_1 = 1, 2$ and $i_2 = 1, 2, 3$.

The vanishing E - and J terms are given by

	J		E
$\Delta_{(1,1)(2,3)} :$	$L^{(2,3)}_{(1,3)} U^{(1,3)}_{(1,1)} - U^{(2,3)}_{(2,1)} L^{(2,1)}_{(1,1)} = 0$	$D^{(1,1)}_{(1,3)} R^{(1,3)}_{(2,3)} - R^{(1,1)}_{(2,1)} D^{(2,1)}_{(2,3)} = 0$	
$\Delta_{(1,2)(2,1)} :$	$L^{(2,1)}_{(1,1)} U^{(1,1)}_{(1,2)} - U^{(2,1)}_{(2,2)} L^{(2,2)}_{(1,2)} = 0$	$D^{(1,2)}_{(1,1)} R^{(1,1)}_{(2,1)} - R^{(1,2)}_{(2,2)} D^{(2,2)}_{(2,1)} = 0$	
$\Delta_{(1,3)(2,2)} :$	$L^{(2,2)}_{(1,2)} U^{(1,2)}_{(1,3)} - U^{(2,2)}_{(2,3)} L^{(2,3)}_{(1,3)} = 0$	$D^{(1,3)}_{(1,2)} R^{(1,2)}_{(2,2)} - R^{(1,3)}_{(2,3)} D^{(2,3)}_{(2,2)} = 0$	
$\Delta_{(2,1)(1,3)} :$	$L^{(1,3)}_{(2,3)} U^{(2,3)}_{(2,1)} - U^{(1,3)}_{(1,1)} L^{(1,1)}_{(2,1)} = 0$	$D^{(2,1)}_{(2,3)} R^{(2,3)}_{(1,3)} - R^{(2,1)}_{(1,1)} D^{(1,1)}_{(1,3)} = 0$	
$\Delta_{(2,2)(1,1)} :$	$L^{(1,1)}_{(2,1)} U^{(2,1)}_{(2,2)} - U^{(1,1)}_{(1,2)} L^{(1,2)}_{(2,2)} = 0$	$D^{(2,2)}_{(2,1)} R^{(2,1)}_{(1,1)} - R^{(2,2)}_{(1,2)} D^{(1,2)}_{(1,1)} = 0$	
$\Delta_{(2,3)(1,2)} :$	$L^{(1,2)}_{(2,2)} U^{(2,2)}_{(2,3)} - U^{(1,2)}_{(1,3)} L^{(1,3)}_{(2,3)} = 0$	$D^{(2,3)}_{(2,2)} R^{(2,2)}_{(1,2)} - R^{(2,3)}_{(1,3)} D^{(1,3)}_{(1,2)} = 0$	
$\nabla_{(1,1)(2,3)} :$	$U^{(2,3)}_{(2,1)} R^{(2,1)}_{(1,1)} - R^{(2,3)}_{(1,3)} U^{(1,3)}_{(1,1)} = 0$	$D^{(1,1)}_{(1,3)} L^{(1,3)}_{(2,3)} - L^{(1,1)}_{(2,1)} D^{(2,1)}_{(2,3)} = 0$	
$\nabla_{(1,2)(2,1)} :$	$U^{(2,1)}_{(2,2)} R^{(2,2)}_{(1,2)} - R^{(2,1)}_{(1,1)} U^{(1,1)}_{(1,2)} = 0$	$D^{(1,2)}_{(1,1)} L^{(1,1)}_{(2,1)} - L^{(1,2)}_{(2,2)} D^{(2,2)}_{(2,1)} = 0$	
$\nabla_{(1,3)(2,2)} :$	$U^{(2,2)}_{(2,3)} R^{(2,3)}_{(1,3)} - R^{(2,2)}_{(1,2)} U^{(1,2)}_{(1,3)} = 0$	$D^{(1,3)}_{(1,2)} L^{(1,2)}_{(2,2)} - L^{(1,3)}_{(2,3)} D^{(2,3)}_{(2,2)} = 0$	
$\nabla_{(2,1)(1,2)} :$	$U^{(1,2)}_{(1,1)} R^{(1,1)}_{(2,1)} - R^{(1,2)}_{(2,2)} U^{(2,2)}_{(2,1)} = 0$	$D^{(2,1)}_{(2,2)} L^{(2,2)}_{(1,2)} - L^{(2,1)}_{(1,1)} D^{(1,1)}_{(1,2)} = 0$	
$\nabla_{(2,2)(1,1)} :$	$U^{(1,1)}_{(1,2)} R^{(1,2)}_{(2,2)} - R^{(1,1)}_{(2,1)} U^{(2,1)}_{(2,2)} = 0$	$D^{(2,2)}_{(2,1)} L^{(2,1)}_{(1,1)} - L^{(2,2)}_{(1,2)} D^{(1,2)}_{(1,1)} = 0$	
$\nabla_{(2,3)(1,2)} :$	$U^{(1,2)}_{(1,3)} R^{(1,3)}_{(2,3)} - R^{(1,2)}_{(2,2)} U^{(2,2)}_{(2,3)} = 0$	$D^{(2,3)}_{(2,2)} L^{(2,2)}_{(1,2)} - L^{(2,3)}_{(1,3)} D^{(1,3)}_{(1,2)} = 0$	
$\Lambda_{(1,1)(1,1)} :$	$R^{(1,1)}_{(2,1)} L^{(2,1)}_{(1,1)} - L^{(1,1)}_{(2,1)} R^{(2,1)}_{(1,2)} = 0$	$D^{(1,1)}_{(1,2)} U^{(1,2)}_{(1,1)} - U^{(1,1)}_{(1,2)} D^{(1,2)}_{(1,1)} = 0$	
$\Lambda_{(1,2)(1,2)} :$	$R^{(1,2)}_{(2,2)} L^{(2,2)}_{(2,1)} - L^{(1,2)}_{(2,2)} R^{(2,2)}_{(1,2)} = 0$	$D^{(1,2)}_{(1,1)} U^{(1,1)}_{(1,2)} - U^{(1,2)}_{(1,1)} D^{(1,1)}_{(1,2)} = 0$	
$\Lambda_{(1,3)(1,3)} :$	$R^{(1,3)}_{(2,3)} L^{(2,3)}_{(1,3)} - L^{(1,3)}_{(2,3)} R^{(2,3)}_{(1,3)} = 0$	$D^{(1,3)}_{(1,2)} U^{(1,2)}_{(1,3)} - U^{(1,3)}_{(1,1)} D^{(1,1)}_{(1,3)} = 0$	
$\Lambda_{(2,1)(2,1)} :$	$R^{(2,1)}_{(1,1)} L^{(1,1)}_{(2,1)} - L^{(2,1)}_{(1,1)} R^{(1,1)}_{(2,1)} = 0$	$D^{(2,1)}_{(2,2)} U^{(2,2)}_{(2,1)} - U^{(2,1)}_{(2,2)} D^{(2,2)}_{(2,1)} = 0$	
$\Lambda_{(2,2)(2,2)} :$	$R^{(2,2)}_{(1,1)} L^{(1,1)}_{(2,2)} - L^{(2,2)}_{(1,1)} R^{(1,2)}_{(2,2)} = 0$	$D^{(2,2)}_{(2,1)} U^{(2,1)}_{(2,2)} - U^{(2,2)}_{(2,1)} D^{(2,1)}_{(2,2)} = 0$	
$\Lambda_{(2,3)(2,3)} :$	$R^{(2,3)}_{(1,3)} L^{(1,3)}_{(2,3)} - L^{(2,3)}_{(1,3)} R^{(1,3)}_{(2,3)} = 0$	$D^{(2,3)}_{(2,2)} U^{(2,2)}_{(2,3)} - U^{(2,3)}_{(2,1)} D^{(2,1)}_{(2,3)} = 0$	

The quiver diagram is shown in Figure 10. The T-dual brane box model is 2×3 D3-brane box model, as depicted in Figure 10.

4.1.6 $\mathbb{C}^2/\mathbb{Z}_3 \times \mathbb{C}^2/\mathbb{Z}_3$ (1, 2, 0, 0), (0, 0, 1, 2)

In this case gauge group is

$$G = \prod_{i_1=1}^3 \prod_{i_2=1}^3 U(N)_{i_1, i_2} \quad (4.20)$$

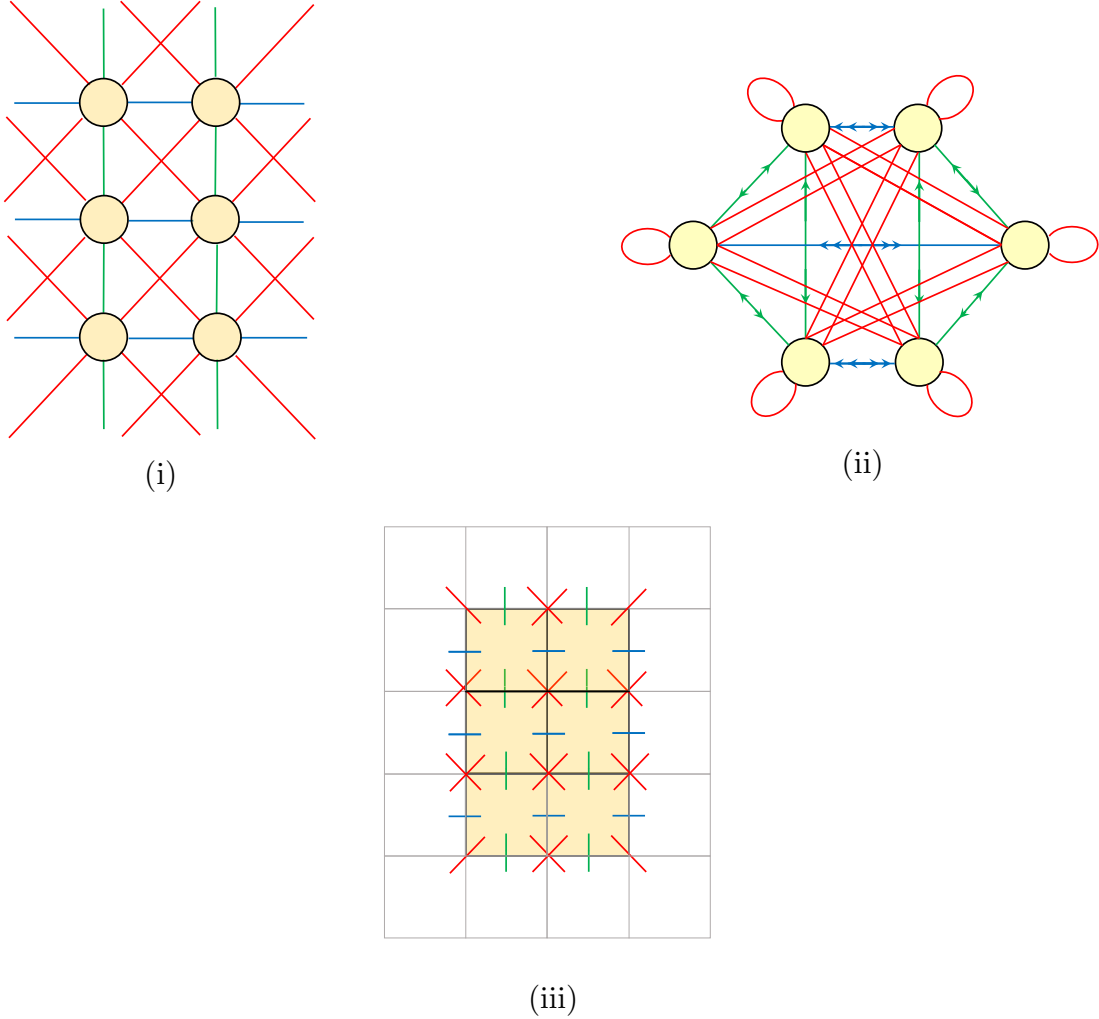

Figure 10: (i) $\mathcal{N} = (0, 4)$ quiver diagram for D1-branes on $\mathbb{C}^2/\mathbb{Z}_2 \times \mathbb{C}^2/\mathbb{Z}_3$. (ii) The corresponding $\mathcal{N} = (0, 2)$ quiver diagram. (iii) D3-brane box configuration which is T-dual to D1-branes on $\mathbb{C}^2/\mathbb{Z}_2 \times \mathbb{C}^2/\mathbb{Z}_3$.

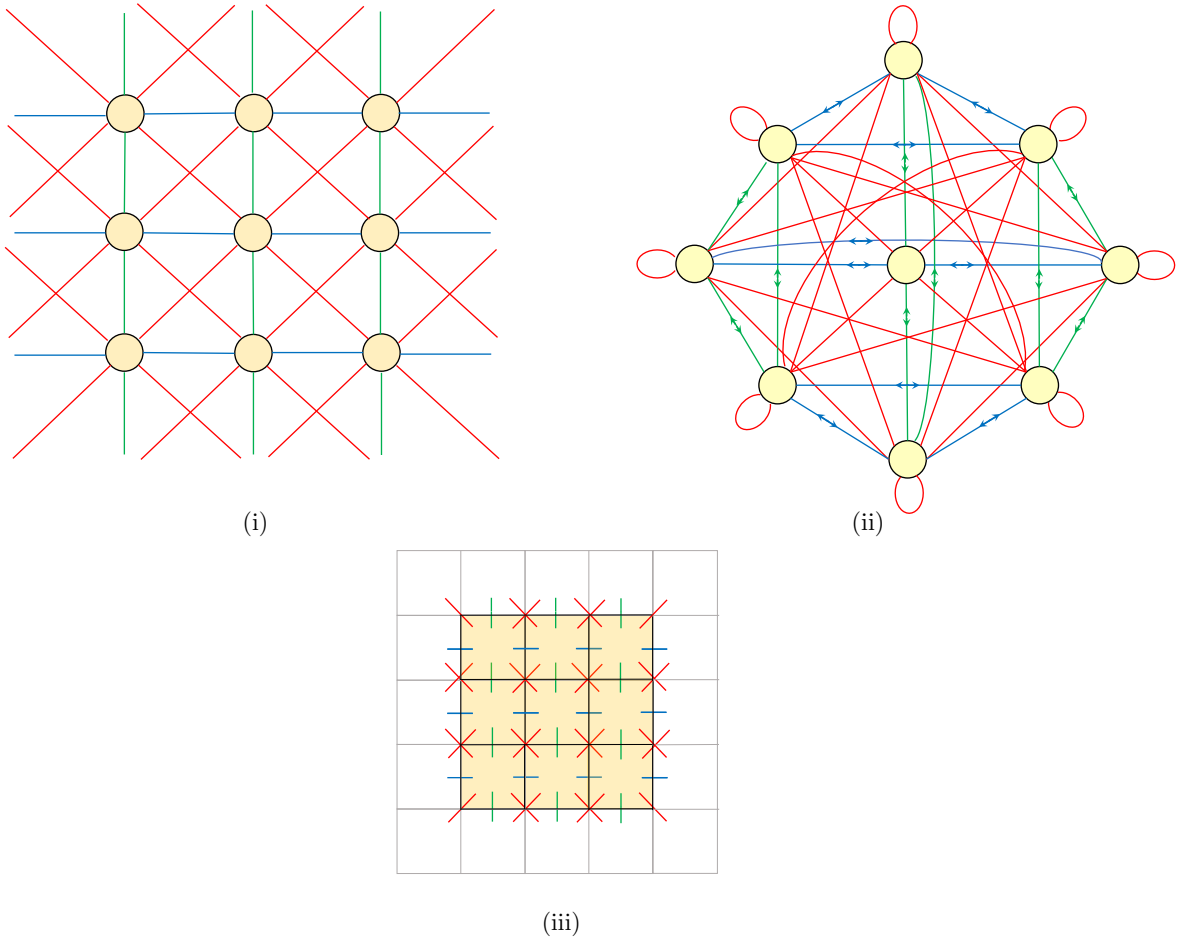

Figure 11: (i) $\mathcal{N} = (0, 4)$ quiver diagram for D1-branes on $\mathbb{C}^2/\mathbb{Z}_3 \times \mathbb{C}^2/\mathbb{Z}_3$. (ii) The corresponding $\mathcal{N} = (0, 2)$ quiver diagram. (iii) 3×3 D3-brane box configuration which is T-dual to D1-branes on $\mathbb{C}^2/\mathbb{Z}_3 \times \mathbb{C}^2/\mathbb{Z}_3$.

and there are 36 chiral multiplets and 27 Fermi multiplets. The quiver diagram is shown in Figure 11. Note that unlike the above examples, the Fermi multiplets cannot be drawn as a bi-fundamental single line since each of $\mathcal{N} = (0, 2)$ Fermi multiplets connects to distinct four gauge nodes. This always happens when both k and k' are larger than two. Therefore the Fermi multiplets generically take the V-shaped or X-shaped configuration.

The T-dual configuration is 3×3 boxes of D3-branes shown in Figure 11.

4.2 D1-D5-D5' branes

Now consider the dynamics of N D1-branes intersecting with N_f D5-branes and N'_f D5'-branes. The space-time symmetry is $SO(1, 1)_{01} \times SO(4)_{2'345} \times SO(4)_{6'789}$. The low-energy effective world-volume theory is $\mathcal{N} = (0, 4)$ supersymmetric $U(N)$ gauge theory with $SU(N_f) \times SU(N'_f)$ global symmetry. In addition to the massless modes from D1-D1 string, there are three sets of multiplets appear from D1-D5, D1-D5' and D5-D5' strings. This brane configuration is studied in [15]. It is shown that the $\mathcal{N} = (0, 4)$ gauge theory flows to the conformal field theory with the central charge

$$c = 6N \frac{N_f N'_f}{N_f + N'_f} \quad (4.21)$$

which is evaluated from the near horizon geometry [30] of $AdS_3 \times S^3 \times S^3 \times \mathbb{R}$ [12, 13, 14]. Let us firstly give a brief review of the $\mathcal{N} = (0, 4)$ gauge theory that arises from the intersection of D1-D5-D5' brane system.

D1-D1 strings As discussed in the previous section, the world-volume theory of N D1-branes is $\mathcal{N} = (8, 8)$ supersymmetric $U(N)$ gauge theory. The theory contains a $\mathcal{N} = (0, 2)$ gauge multiplet, four $\mathcal{N} = (0, 2)$ adjoint chiral multiplets and three $\mathcal{N} = (0, 2)$ adjoint Fermi multiplets. The matter content is summarized as

$\mathcal{N} = (0, 4)$ supermultiplets	$SU(2)_C \times SU(2)'_C \times SU(2)_H \times SU(2)'_H$
adjoint hypermultiplet : (R^i_i, L^i_i)	bosons : $(\mathbf{1}, \mathbf{1}, \mathbf{2}, \mathbf{2})$ fermions : $(\mathbf{2}, \mathbf{1}, \mathbf{1}, \mathbf{2})$
adjoint twisted hypermultiplet : (U^i_i, D^i_i)	bosons : $(\mathbf{2}, \mathbf{2}, \mathbf{1}, \mathbf{1})$ fermions : $(\mathbf{1}, \mathbf{2}, \mathbf{2}, \mathbf{1})$
adjoint Fermi multiplets : $(\Delta_{ii}, \nabla_{ii})$	fermions : $(\mathbf{1}, \mathbf{2}, \mathbf{1}, \mathbf{2})$

(4.22)

There is also the $\mathcal{N} = (0, 4)$ $U(N)$ vector multiplet consisting of the $\mathcal{N} = (0, 2)$ gauge multiplet and the $\mathcal{N} = (0, 2)$ adjoint Fermi multiplet. As in the brane setup (4.1), the hypermultiplet scalar fields describe the dynamics of D1-branes along 6'7898 in which D5-branes extend, while the twisted hypermultiplet scalar fields capture the motions of D1-branes along 2'345 in which D5'-branes span. The E - and J -terms are given by (4.2).

D1-D5 strings The massless modes coming from the open strings stretched between D1-branes and D5-branes give rise to $\mathcal{N} = (4, 4)$ hypermultiplets. In our brane construction (4.1), they decompose into $\mathcal{N} = (0, 4)$ hypermultiplets and $\mathcal{N} = (0, 4)$ Fermi multiplets transforming as follows:

$\mathcal{N} = (0, 4)$ supermultiplets	$SU(2)_C \times SU(2)'_C \times SU(2)_H \times SU(2)'_H$
fundamental hypermultiplets : $(H^i_a, \widetilde{H}^a_i)$	bosons : $(\mathbf{1}, \mathbf{1}, \mathbf{2}, \mathbf{1})$ fermions : $(\mathbf{2}, \mathbf{1}, \mathbf{1}, \mathbf{1})$
fundamental Fermi multiplets : $(\xi^i_a, \widetilde{\xi}^a_i)$	fermions : $(\mathbf{1}, \mathbf{2}, \mathbf{1}, \mathbf{1})$

(4.23)

Here H_a^i, \tilde{H}_i^a are $\mathcal{N} = (0, 2)$ chiral multiplets and $\xi_a^i, \tilde{\xi}_i^a$ are $\mathcal{N} = (0, 2)$ Fermi multiplets where $i = 1, \dots, N$ are gauge indices and $a = 1, \dots, N_f$ are flavor indices.

Each of the $\mathcal{N} = (0, 4)$ supermultiplets transforms as the fundamental representation under the $U(N)$ gauge group and transform as the anti-fundamental representation under the $SU(N_f)$ global symmetry. The fundamental hypermultiplets (H, \tilde{H}) couple to the $U(N)$ vector multiplets through J -term

$$\Lambda^i : \quad \begin{array}{c} J \\ \tilde{H}_i^a \cdot H_a^i = 0 \end{array} \quad (4.24)$$

associated to the adjoint $\mathcal{N} = (0, 2)$ Fermi multiplet Λ_{ii} in the $\mathcal{N} = (0, 4)$ vector multiplet.

The fundamental hypermultiplet (H, \tilde{H}) can also couple to the adjoint twisted hypermultiplet (U, D) appearing in the D1-D1 string spectrum (4.26) through the E - and J -terms associated to the Fermi multiplet $(\xi, \tilde{\xi})$

$$\begin{array}{l} \xi_a^i : \quad \begin{array}{cc} J & E \\ \tilde{H}_i^a \cdot D^i = 0 & U^i \cdot H_a^i = 0 \end{array} \\ \tilde{\xi}_i^a : \quad \begin{array}{cc} J & E \\ D^i \cdot H_a^i = 0 & -\tilde{H}_i^a \cdot U^i = 0 \end{array} \end{array} \quad (4.25)$$

These interactions reflect the fact that D1-D5 strings become massive when the D1-branes move along the directions parallel to D5'-branes.

D1-D5' strings Similarly to the D1-D5 strings, the massless modes from the open strings stretched between D1-branes and D5'-branes give $\mathcal{N} = (4, 4)$ hypermultiplets. They transform under the space-time symmetry so that they decompose into $\mathcal{N} = (0, 4)$ twisted hypermultiplets (T, \tilde{T}) and $\mathcal{N} = (0, 4)$ Fermi multiplets $(\zeta, \tilde{\zeta})$:

$\mathcal{N} = (0, 4)$ supermultiplets	$SU(2)_C \times SU(2)'_C \times SU(2)_H \times SU(2)'_H$
fundamental twisted hypermultiplets : $(T_a^i, \tilde{T}_i^{\tilde{a}})$	bosons : $(\mathbf{2}, \mathbf{1}, \mathbf{1}, \mathbf{1})$ fermions : $(\mathbf{1}, \mathbf{1}, \mathbf{2}, \mathbf{1})$
fundamental Fermi multiplets : $(\zeta_a^i, \tilde{\zeta}_i^{\tilde{a}})$	fermions : $(\mathbf{1}, \mathbf{1}, \mathbf{1}, \mathbf{2})$

(4.26)

where $T_a^i, \tilde{T}_i^{\tilde{a}}$ are $\mathcal{N} = (0, 2)$ chiral multiplets and $\zeta_a^i, \tilde{\zeta}_i^{\tilde{a}}$ are $\mathcal{N} = (0, 2)$ Fermi multiplets with $\tilde{a} = 1, \dots, N'_f$ being flavor indices.

They transform as the fundamental representations under the $U(N)$ gauge group. Under the $SU(N'_f)$ global symmetry, they transform as the anti-fundamental representation. The $\mathcal{N} = (0, 4)$ twisted hypermultiplet is coupled to $U(N)$ vector multiplet through E -term

$$\Lambda^i : \quad \begin{array}{c} E \\ T_a^i \cdot \tilde{T}_i^{\tilde{a}} = 0 \end{array} \quad (4.27)$$

They also couple to the adjoint hypermultiplets (R, L) in (4.23) through the E - and J -term potentials for the Fermi multiplets $(\zeta, \tilde{\zeta})$

$$\begin{array}{l} \zeta_a^i : \quad \begin{array}{cc} J & E \\ \tilde{T}_i^{\tilde{a}} \cdot L^i = 0 & R^i \cdot T_a^i = 0 \end{array} \\ \tilde{\zeta}_i^{\tilde{a}} : \quad \begin{array}{cc} J & E \\ L^i \cdot T_a^i = 0 & -\tilde{T}_i^{\tilde{a}} \cdot R^i = 0 \end{array} \end{array} \quad (4.28)$$

The presence of these interactions implies that the D1-D5' strings become massive when the D1-branes move in the directions where the D5-branes span.

D5-D5' strings The quantization of open strings stretched between D5- and D5'-branes leads to the $\mathcal{N} = (0, 8)$ Fermi multiplets, as a pair of $\mathcal{N} = (0, 4)$ Fermi multiplets ⁴.

$\mathcal{N} = (0, 4)$ supermultiplets	$SU(2)_C \times SU(2)'_C \times SU(2)_H \times SU(2)'_H$	
neutral Fermi multiplets : $(\gamma_{\tilde{a}}^a, \tilde{\gamma}_{\tilde{a}}^{\tilde{a}})$	$(\mathbf{1}, \mathbf{1}, \mathbf{1}, \mathbf{1})$	(4.29)
neutral Fermi multiplets : $(\gamma'_{\tilde{a}}{}^a, \tilde{\gamma}'_{\tilde{a}}{}^{\tilde{a}})$	$(\mathbf{1}, \mathbf{1}, \mathbf{1}, \mathbf{1})$	

The $\mathcal{N} = (0, 4)$ Fermi multiplets are neutral under the gauge group. So they have no interaction with the $\mathcal{N} = (0, 4)$ vector multiplet. Meanwhile, they transform as bi-fundamental representation under the $SU(N_f) \times SU(N'_f)$ global symmetry.

Without any E - and J -potential terms of these Fermi multiplets $(\gamma, \tilde{\gamma})$, when both D5- and D5'-branes exist, it follows that $E \cdot J = E_\Lambda \cdot J_\Lambda = T\tilde{T}H\tilde{H} \neq 0$. The supersymmetric constraint (2.22) can hold if one of the $\mathcal{N} = (0, 4)$ Fermi multiplets, which we take $(\gamma, \tilde{\gamma})$, are couple to both fundamental hypermultiplets (H, \tilde{H}) and fundamental twisted hypermultiplets (T, \tilde{T}) via E - and J -terms

$$\begin{array}{l}
 \begin{array}{cc}
 & J & E \\
 \gamma_{\tilde{a}}^a : & \frac{1}{\sqrt{2}} H_a^i \cdot \tilde{T}_i^{\tilde{a}} = 0 & -\frac{1}{\sqrt{2}} T_{\tilde{a}}^i \cdot \tilde{H}_i^a = 0 \\
 \tilde{\gamma}_{\tilde{a}}^{\tilde{a}} : & \frac{1}{\sqrt{2}} T_{\tilde{a}}^i \cdot \tilde{H}_i^a = 0 & -\frac{1}{\sqrt{2}} H_a^i \cdot \tilde{T}_i^{\tilde{a}} = 0
 \end{array}
 \end{array} \tag{4.30}$$

To sum, the $\mathcal{N} = (0, 4)$ gauge theory of D1-D5-D5' brane system is encoded in the quiver diagram of Figure 12. The two square nodes represent $SU(N_f)$ and $SU(N'_f)$ flavor symmetries.

The T-dual brane configuration is depicted in Figure 12. NS5- and D5-branes are depicted as vertical bold and dotted lines while NS5'- and D5'-branes are depicted as horizontal bold and dotted lines. A single box of D3-branes surrounded by a NS5-brane and NS5'-brane correspond to the gauge node. The D3-branes intersect with N_f D5-branes and N'_f D5'-branes which are associated to the $SU(N)_f$ and $SU(N)'_f$ flavor symmetry.

4.3 D1-D5-D5' branes on $\mathbb{C}^2/\mathbb{Z}_k \times \mathbb{C}^2/\mathbb{Z}_{k'}$

Generic brane box configuration consisting of a grid of k NS5-branes and k' NS5'-branes is T-dual of D1-D5-D5' brane system on the singularity $\mathbb{C}^2/\mathbb{Z}_k \times \mathbb{C}^2/\mathbb{Z}_{k'}$. For simplicity let us concentrate on the generator of orbifold group labeled by $(1, 1, 0, 0)$ and $(0, 0, 1, 1)$. In order for the $SU(2)_C \times SU(2)_H$ R-symmetry of $\mathcal{N} = (0, 4)$ supersymmetry to be preserved, the orbifold groups \mathbb{Z}_k and $\mathbb{Z}_{k'}$ should be embedded in $SU(2)'_H$ and $SU(2)'_C$ respectively

$$\begin{aligned}
 \mathbb{Z}_k &\subset SU(2)'_H \subset SO(4)_{6'789}, \\
 \mathbb{Z}_{k'} &\subset SU(2)'_C \subset SO(4)_{2'345}.
 \end{aligned} \tag{4.31}$$

In addition to the restriction on fields from D1-D1 strings, which we have already seen, there is a further restriction on fields from D1-D5 strings, D1-D5' strings and D5-D5' strings. The action of $\mathbb{Z}_{k'}$ should be embedded in the Chan Paton factors of N_f D5-branes and that of \mathbb{Z}_k should be embedded in the Chan Paton factors of N'_f D5'-branes so that flavor symmetry group is

$$G_F = \prod_{i_1=1}^k SU(N'_f)_{i_1} \prod_{i_2=1}^{k'} SU(N_f)_{i_2}. \tag{4.32}$$

From (4.23)-(4.29) we see that only orbifold actions on $(0, 4)$ Fermi multiplets from D1-D5 strings and from D1-D5' strings are non-trivial, that is $(\xi_a^i, \tilde{\xi}_i^a)$ transforming as $\mathbf{2}$ under the $SU(2)'_C$ and

⁴This is T-dual configuration of D0-D8 brane system [31, 32].

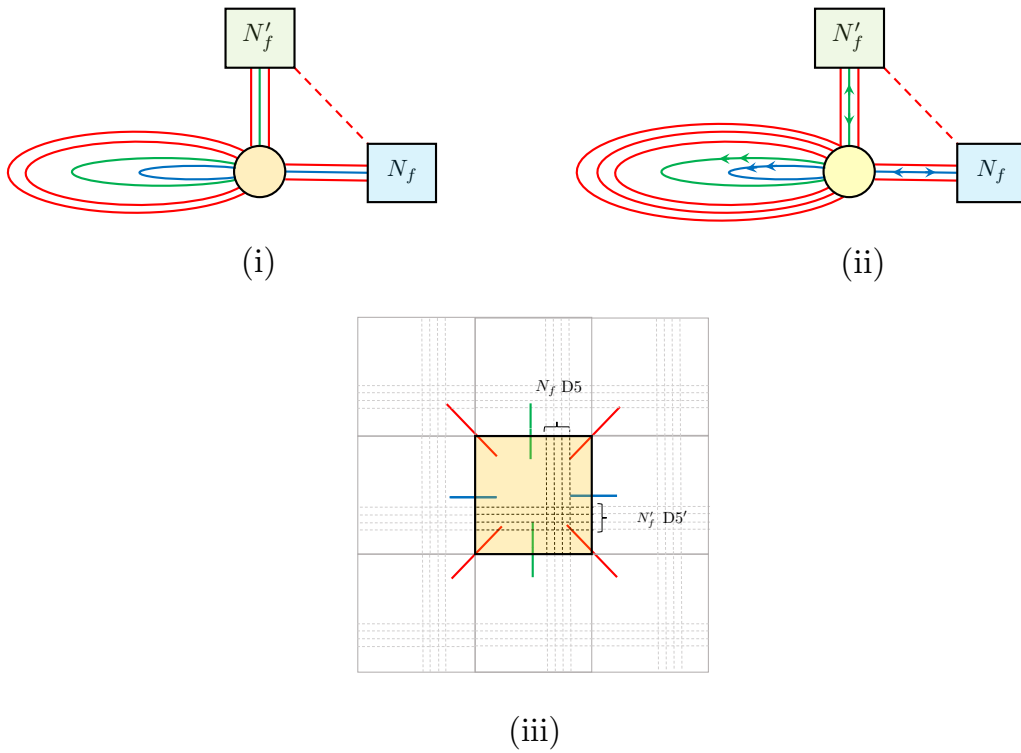

Figure 12: (i) $\mathcal{N} = (0, 4)$ quiver of D1-D5-D5' brane system. The dotted red line represents neutral Fermi multiplets. (ii) The corresponding $\mathcal{N} = (0, 2)$ quiver. (iii) A single brane box of D3-branes with flavor D5- and D5'-branes. This is T-dual configuration of D1-D5-D5' brane system.

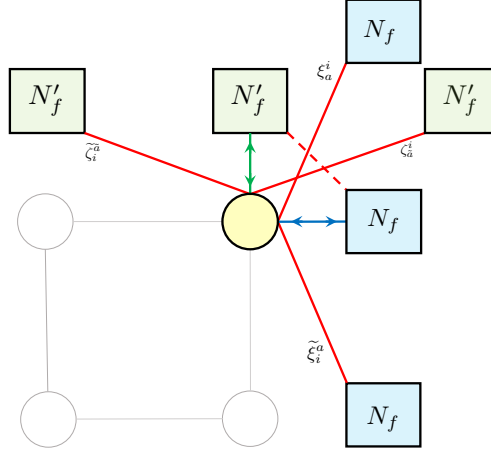

Figure 13: A quiver diagram of adding N_f flavor D5- and N'_f D5'-branes to D1-branes in the presence of the singularity. Each of blue square boxes represents $SU(N_f)$ flavor symmetry while each of green square boxes represents $SU(N'_f)$ flavor symmetry. The blue and green edges are fundamental $\mathcal{N} = (0, 4)$ hyper and twisted hypermultiplets. The red bold lines are Fermi multiplets. The red dotted line is neutral $\mathcal{N} = (0, 4)$ Fermi multiplets.

$(\zeta_a^i, \tilde{\zeta}_i^a)$ transforming as $\mathbf{2}$ under the $SU(2)'_H$. Let $\tilde{a}_{i_1} = 1, \dots, N'_f$ and $a_{i_2} = 1, \dots, N_f$ stand for i_1 -th $SU(N'_f)$ flavor indices and i_2 -th $SU(N_f)$ flavor indices respectively. Under the gauge group (4.4) and flavor symmetry group (4.32) these Fermi multiplets transform as

$$\begin{aligned}
\xi_a^i &: (i; a) = (i_1, i_2; a_{i_2+1}) \\
\tilde{\xi}_i^a &: (i; a) = (i_1, i_2; a_{i_2-1}) \\
\zeta_a^i &: (i; \tilde{a}) = (i_1, i_2; \tilde{a}_{i_1+1}) \\
\tilde{\zeta}_i^a &: (i; \tilde{a}) = (i_1, i_2; \tilde{a}_{i_1-1}).
\end{aligned} \tag{4.33}$$

We give a quiver diagram for adding N_f D5- and N'_f D5'-branes to D1-branes on $\mathbb{Z}_k \times \mathbb{Z}_{k'}$ in Figure 13. Each of k' blue square boxes which are vertically aligned represents the $SU(N_f)$ flavor symmetry while each of k green square boxes which are horizontally aligned represents the $SU(N'_f)$ flavor symmetry. The blue and green edges are $\mathcal{N} = (0, 4)$ fundamental hypermultiplets (H_a^i, \tilde{H}_i^a) and twisted hypermultiplets (T_a^i, \tilde{T}_i^a). The red lines connecting between gauge nodes and $SU(N_f)$ boxes are the Fermi multiplets ($\xi_a^i, \tilde{\xi}_i^a$) and those connecting between gauge nodes and $SU(N'_f)$ boxes are the Fermi multiplets ($\zeta_a^i, \tilde{\zeta}_i^a$). The red dotted line is the neutral $\mathcal{N} = (0, 4)$ Fermi multiplets ($\gamma_a^i, \tilde{\gamma}_i^a$) which arise from D5-D5' strings.

The E - and J -terms (4.25) associated to $(\xi_a^i, \tilde{\xi}_i^a)$ and the E - and J -terms (4.28) associated to $(\zeta_a^i, \tilde{\zeta}_i^a)$ become

$$\begin{aligned}
& \begin{array}{cc} J & E \end{array} \\
\xi_{a_{i_2+1}}^{(i_1, i_2)} &: \tilde{H}_{(i_1, i_2+1)}^{a_{i_2+1}} \cdot D^{(i_1, i_2+1)}_{(i_1, i_2)} = 0 & U^{(i_1, i_2)}_{(i_1, i_2+1)} \cdot H_{a_{i_2+1}}^{(i_1, i_2+1)} = 0 \\
\tilde{\xi}_{(i_1, i_2)}^{a_{i_2-1}} &: D^{(i_1, i_2)}_{(i_1, i_2-1)} \cdot H_{a_{i_2-1}}^{(i_1, i_2-1)} = 0 & -\tilde{H}_{(i_1, i_2-1)}^{a_{i_2-1}} \cdot U^{(i_1, i_2-1)}_{(i_1, i_2)} = 0 \\
& \dots \\
\tilde{\zeta}_{\tilde{a}_{i_1+1}}^{(i_1, i_2)} &: \tilde{T}_{(i_1+1, i_2)}^{\tilde{a}_{i_1+1}} \cdot L^{(i_1+1, i_2)}_{(i_1, i_2)} = 0 & R^{(i_1, i_2)}_{(i_1+1, i_2)} \cdot T_{\tilde{a}_{i_1+1}}^{(i_1+1, i_2)} = 0 \\
\tilde{\zeta}_{(i_1, i_2)}^{\tilde{a}_{i_1-1}} &: L^{(i_1, i_2)}_{(i_1-1, i_2)} \cdot T_{\tilde{a}_{i_1-1}}^{(i_1-1, i_2)} = 0 & -\tilde{T}_{(i_1-1, i_2)}^{\tilde{a}_{i_1-1}} \cdot R^{(i_1-1, i_2)}_{(i_1, i_2)} = 0
\end{aligned} \tag{4.34}$$

These interactions can be read off from the quiver diagram as in Figure 14 and 15.

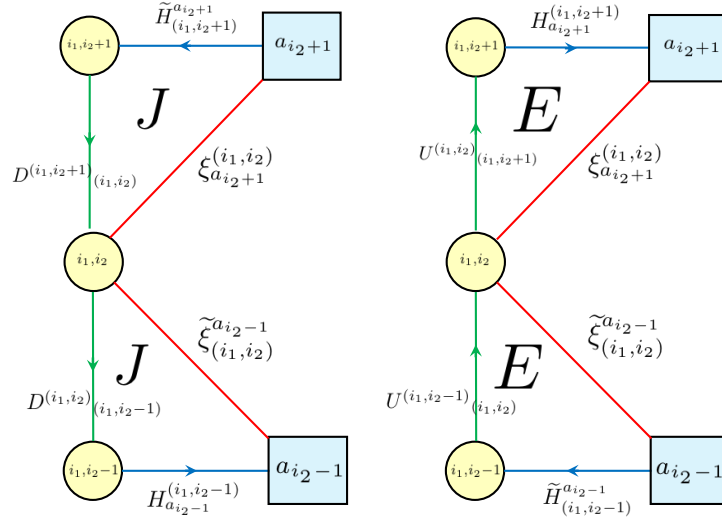

Figure 14: E - and J -terms associated to $(\xi, \tilde{\xi})$. A circular node labeled by a pair of two integers (i_1, i_2) corresponds to (i_1, i_2) -th gauge factor. A blue square box labeled by an integer a_{i_2} corresponds to a_{i_2} -th $SU(N_f)$ flavor factor.

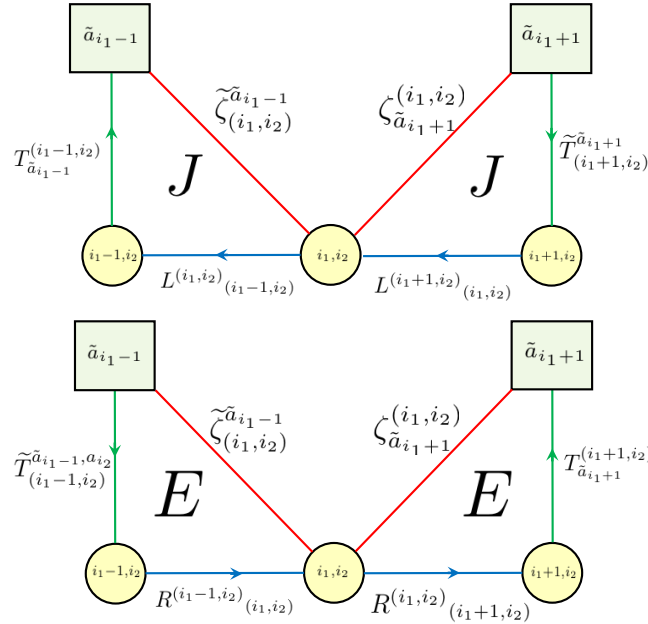

Figure 15: E - and J -terms associated to $(\zeta, \tilde{\zeta})$. A circular node labeled by a pair of two integers (i_1, i_2) corresponds to (i_1, i_2) -th gauge factor. A green square box labeled by an integer \tilde{a}_{i_1} corresponds to \tilde{a}_{i_1} -th $SU(N_f)'$ flavor factor.

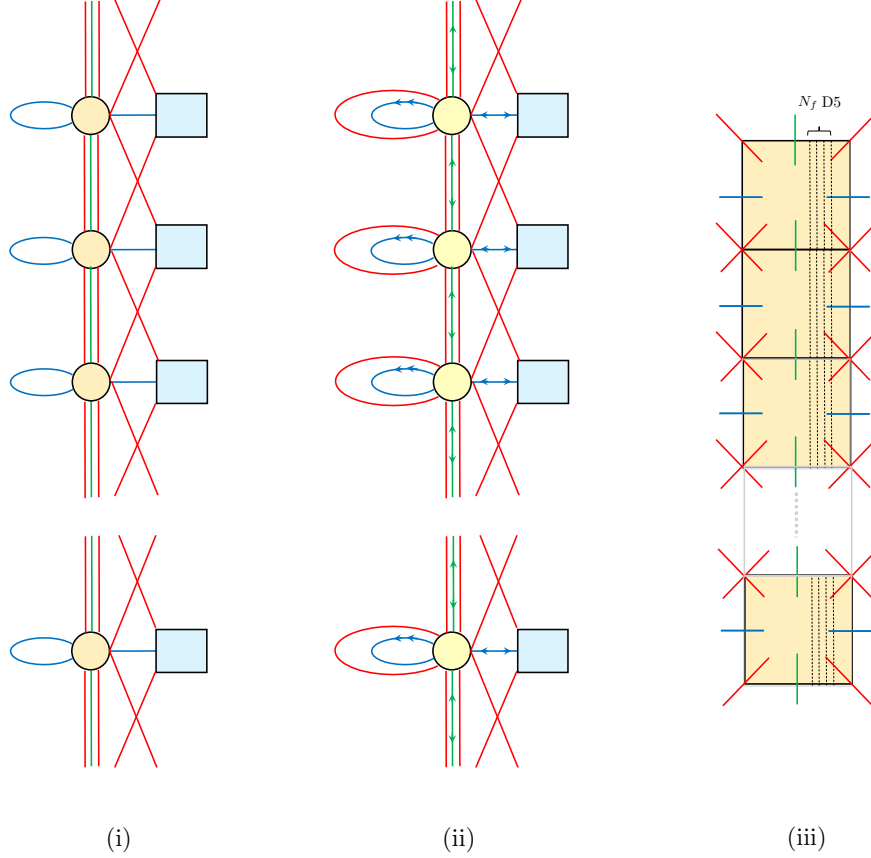

Figure 16: (i) $\mathcal{N} = (0, 4)$ quiver diagram of D1-D5 brane system on $\mathbb{C}^2/\mathbb{Z}_{k'}$. This is a set of inner quiver and outer one. (ii) The corresponding $\mathcal{N} = (0, 2)$ quiver. (iii) The T-dual $(1 \times k')$ D3-brane box configuration with N_f D5-branes.

4.4 Examples

4.4.1 D1-D5-KK' system

When $k = 1$ and $N'_f = 0$, our brane setup reduces to D1-D5 brane system on $\mathbb{C}^2/\mathbb{Z}_{k'}$ ⁵. The low-energy effective theory is $\mathcal{N} = (0, 4)$ gauge theory which is encoded by a set of inner quiver and outer quiver diagram shown in Figure 16. The inner quiver diagram is the affine $\widehat{A}_{k'-1}$ diagram with $U(N)$ gauge nodes corresponding to the orbifold of N D1-branes. The outer quiver diagram is the another affine $\widehat{A}_{k'-1}$ Dynkin diagram with $SU(N_f)$ gauge nodes corresponding to the orbifold of N_f D5-branes.

Each gauge node comes up with a $\mathcal{N} = (0, 4)$ vector multiplet, consisting of a $\mathcal{N} = (0, 2)$ gauge multiplet and an adjoint $\mathcal{N} = (0, 2)$ Fermi multiplet Λ , and an adjoint $\mathcal{N} = (0, 4)$ hypermultiplet (L, R) . Between gauge nodes there is a bi-fundamental $\mathcal{N} = (0, 4)$ twisted hypermultiplet (U, D) and Fermi multiplets (Δ, ∇) . As discussed in section 4.1.4, these are $\mathcal{N} = (4, 4)$ gauge theory encoded in the inner quiver. In addition, there are flavor nodes and links between the inner and outer quiver. They represent fundamental hypermultiplets (H, \tilde{H}) and Fermi multiplets $(\xi, \tilde{\xi})$. It is compatible with the quiver previously studied in [11, 37, 7].

⁵ This brane configuration has been studied in [10, 33, 34, 35, 10, 36].

At low energy the D1-D5-KK' system is described by $\mathcal{N} = (0, 4)$ SCFT of central charge [36]

$$c = 6N_c N_f k'. \quad (4.35)$$

and the microscopic states correspond to the chiral primary operators in the CFT.

The T-dual configuration is $(1 \times k')$ D3-brane boxes including N_f D5-branes illustrated in Figure 16.

4.4.2 Mirrors

We can also consider more general $\mathcal{N} = (0, 4)$ quiver gauge theories in which both D5- and D5'-branes exist at generic singularity. In this case we can study two distinct $\mathcal{N} = (0, 4)$ gauge theories which map to the other under the S-duality in Type IIB string theory.

For example, let us consider 2×2 D3-brane box model in which each of boxes intersecting with flavor N_f D5- and N'_f D5'-branes. Making use of our dictionary, we can easily obtain the quiver diagram illustrated in Figure 17. This is the generalized model of 2×2 D3-brane box model in Figure 9 involving N_f flavor D5 and N'_f D5'-branes. When $N_f = 1$ and $N'_f = 1$, this model is interesting in that it is invariant under the S duality in type IIB string theory, which indicates that the model is self mirror. We postpone further analysis of this issue to the future.

5 Brane box model

Now that we have identified the matter content and interaction of $\mathcal{N} = (0, 4)$ gauge theory for periodic D3-brane box configuration from T-dual configuration of D1-D5-KK system, we would like to further discuss the detail of the brane box model.

5.1 Brane box configuration and anomaly

5.1.1 Anomaly constraint

As discussed in section 2.2.5, $\mathcal{N} = (0, 4)$ gauge theory must be free from gauge anomaly. Consequently only appropriate choices of gauge group and matter content are admitted. To see this constraint in the brane box construction, let us consider a box of N D3-branes surrounded by eight adjacent boxes filled by D3-branes. Taking into account the $\mathcal{N} = (0, 4)$ boundary conditions in subsection 3.2.1, this leads to $\mathcal{N} = (0, 4)$ $U(N)$ vector multiplet. Without any matter multiplets, the $\mathcal{N} = (0, 4)$ $U(N)$ vector multiplet is anomalous.

In the absence of flavor 5-branes, an anomaly free theory is obtained by filling the adjacent D3-branes in (x^2, x^6) plane. Let n_{TL} , n_T , n_{TR} , n_L , n_R , n_{BL} , n_B , n_{BR} be the numbers of D3-branes displaced in the neighboring infinite regions in top-left, top, top-right, left, right, bottom-left, bottom and bottom-right (see Figure 18). Applying the brane rules for matter multiplets as above, the horizontally aligned n_L and n_R D3-branes introduce n_L and n_R $\mathcal{N} = (0, 4)$ bi-fundamental hypermultiplets, the vertically aligned n_T and n_B D3-branes provide n_T and n_B $\mathcal{N} = (0, 4)$ bi-fundamental twisted hypermultiplets, and the diagonally aligned n_{TL} , n_{TR} , n_b and n_{BR} D3-branes lead to n_{TL} , n_{TR} , n_b and n_{BR} bi-fundamental Fermi multiplets. According to the anomaly contribution (2.34), the condition set by the $\mathbf{f}_{\text{su}(N)}^2$ gauge anomaly is given by

$$N = \frac{1}{2}(n_L + n_R + n_T + n_B) - \frac{1}{4}(n_{TL} + n_{TR} + n_{BL} + n_{BR}). \quad (5.1)$$

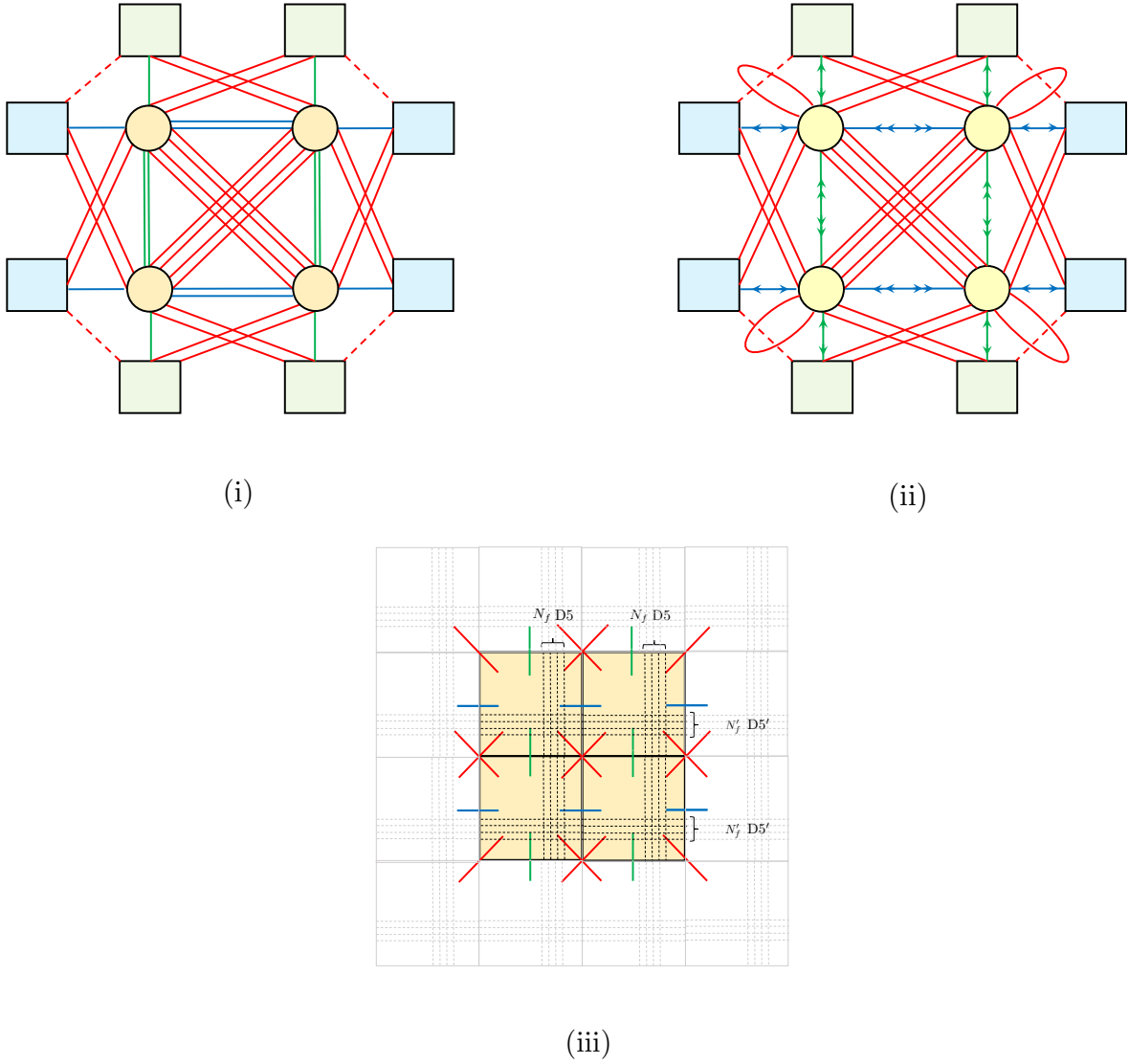

Figure 17: (i) $\mathcal{N} = (0,4)$ quiver diagram for brane box model of (iii). (ii) The corresponding $\mathcal{N} = (0,2)$ quiver. (iii) A grid of two NS5-branes and two NS5'-branes with N_f flavor D5 and N'_f D5'-branes which is T-dual of D1-D5-D5' brane system on $\mathbb{C}^2/\mathbb{Z}_2 \times \mathbb{C}^2/\mathbb{Z}_2$.

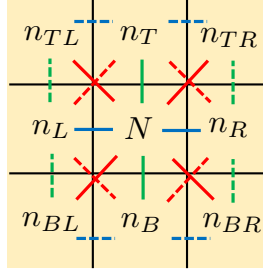

Figure 18: A box of N D3-branes surrounded by eight adjacent boxes filled by D3-branes. Blue, green and red solid edges correspond to hyper, twisted hyper and Fermi multiplets respectively. Blue and green dotted edges represent 3d hyper and twisted hypermultiplets respectively. Red dotted edges are neutral Fermi multiplets.

In the absence of D5- or D5'-branes, this constraint on the occupation numbers of D3-branes in the adjacent boxes is required for gauge anomaly cancellation.

5.1.2 Junction tetravalent Fermi multiplet

Although the condition (5.1) fixes the $\mathbf{f}_{\mathfrak{su}(N)}^2$ gauge anomaly, the Abelian part is still anomalous because the Abelian gaugino has no contribution to the gauge anomaly. To see this precisely, let us compute the Abelian gauge anomaly polynomial by setting all the numbers of D3-branes to be one. We denote the field strength for the gauge and flavor symmetries which are associated to the multiplicities of D3-branes in Figure 18 as

$$\begin{array}{c|c|c|c|c|c|c|c|c}
 n_{TL} & n_T & n_{TR} & n_L & N & n_R & n_{BL} & n_B & n_{BR} \\
 \hline
 \mathbf{a} & \mathbf{b} & \mathbf{c} & \mathbf{d} & \mathbf{s} & \mathbf{e} & \mathbf{f} & \mathbf{g} & \mathbf{h}
 \end{array} \tag{5.2}$$

The two-dimensional fields which are illustrated as solid lines in Figure 18 have the following contributions to the Abelian gauge anomaly polynomial:

$$\begin{aligned}
 \mathcal{I}^{2d \text{ bdy}} &= \underbrace{-2(\mathbf{s} - \mathbf{e})^2 - 2(\mathbf{d} - \mathbf{s})^2}_{(0,4) \text{ hypermultiplets}} - \underbrace{2(\mathbf{s} - \mathbf{b})^2 - 2(\mathbf{g} - \mathbf{s})^2}_{(0,4) \text{ twisted hypermultiplets}} + \underbrace{(\mathbf{s} - \mathbf{f})^2 + (\mathbf{s} - \mathbf{h})^2 + (\mathbf{a} - \mathbf{s})^2 + (\mathbf{c} - \mathbf{s})^2}_{\text{Fermi multiplets}} \\
 &= \mathbf{a}^2 - 2\mathbf{b}^2 + \mathbf{c}^2 - 2\mathbf{d}^2 - 2\mathbf{e}^2 + \mathbf{f}^2 - 2\mathbf{g}^2 + \mathbf{h}^2 \\
 &\quad - 2\mathbf{a} \cdot \mathbf{s} + 4\mathbf{b} \cdot \mathbf{s} - 2\mathbf{c} \cdot \mathbf{s} + 4\mathbf{d} \cdot \mathbf{s} + 4\mathbf{e} \cdot \mathbf{s} - 2\mathbf{f} \cdot \mathbf{s} + 4\mathbf{g} \cdot \mathbf{s} - 2\mathbf{h} \cdot \mathbf{s} - 4\mathbf{s}^2.
 \end{aligned} \tag{5.3}$$

The non-vanishing terms which include the field strength \mathbf{s} of the Abelian gauge field, provide the anomalous contributions. In addition, the three-dimensional bulk matter fields which are illustrated as dotted blue and green lines obeying the boundary conditions lead to the following contributions to the Abelian global anomaly:

$$\begin{aligned}
 \mathcal{I}^{3d \text{ matter}} &= \underbrace{-(\mathbf{a} - \mathbf{b})^2 - (\mathbf{b} - \mathbf{c})^2 - (\mathbf{f} - \mathbf{g})^2 - (\mathbf{g} - \mathbf{h})^2}_{\text{N b.c. of 3d hypermultiplets}} - \underbrace{-(\mathbf{d} - \mathbf{a})^2 - (\mathbf{e} - \mathbf{c})^2 - (\mathbf{f} - \mathbf{d})^2 - (\mathbf{h} - \mathbf{e})^2}_{\text{N b.c. of 3d twisted hypermultiplets}} \\
 &= -2\mathbf{a}^2 + 2\mathbf{a} \cdot \mathbf{b} - 2\mathbf{b}^2 + 2\mathbf{b} \cdot \mathbf{c} - 2\mathbf{c}^2 + 2\mathbf{a} \cdot \mathbf{d} - 2\mathbf{d}^2 + 2\mathbf{c} \cdot \mathbf{e} \\
 &\quad - 2\mathbf{e}^2 + 2\mathbf{d} \cdot \mathbf{f} - 2\mathbf{f}^2 + 2\mathbf{f} \cdot \mathbf{g} - 2\mathbf{g}^2 + 2\mathbf{e} \cdot \mathbf{h} + 2\mathbf{g} \cdot \mathbf{h} - 2\mathbf{h}^2.
 \end{aligned} \tag{5.4}$$

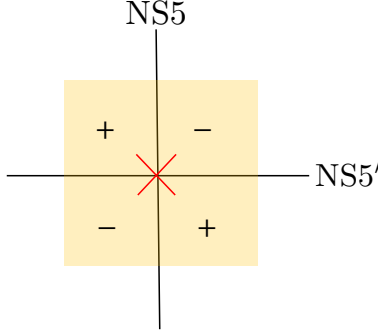

Figure 19: The tetravalent Fermi multiplet living at NS5-NS5' junction. This is required to cancel the Abelian gauge anomaly in such a way that it couples to the Abelian parts of quadrant of the gauge or/and global symmetries. It has the same charges along diagonal boxes.

Furthermore, there are four neutral Fermi multiplets illustrated as red dotted lines in Figure 18 which contribute to the Abelian global anomaly

$$\begin{aligned} \mathcal{I}^{\text{neutral Fermi}} &= (\mathbf{b} - \mathbf{d})^2 + (\mathbf{b} - \mathbf{e})^2 + (\mathbf{d} - \mathbf{g})^2 + (\mathbf{e} - \mathbf{g})^2 \\ &= 2\mathbf{b}^2 - 2\mathbf{b} \cdot \mathbf{d} + 2\mathbf{d}^2 - 2\mathbf{b} \cdot \mathbf{e} + 2\mathbf{e}^2 - 2\mathbf{d} \cdot \mathbf{g} - 2\mathbf{e} \cdot \mathbf{g} + 2\mathbf{g}^2. \end{aligned} \quad (5.5)$$

Collecting the contributions (5.3)-(5.5), we have

$$\begin{aligned} &\mathcal{I}^{2\text{d bdy}} + \mathcal{I}^{3\text{d matter}} + \mathcal{I}^{\text{neutral Fermi}} \\ &= -\mathbf{a}^2 + 2\mathbf{a} \cdot \mathbf{b} - 2\mathbf{b}^2 + 2\mathbf{b} \cdot \mathbf{c} - \mathbf{c}^2 + 2\mathbf{a} \cdot \mathbf{d} - 2\mathbf{b} \cdot \mathbf{d} - 2\mathbf{d}^2 - 2\mathbf{b} \cdot \mathbf{e} + 2\mathbf{c} \cdot \mathbf{e} \\ &\quad - 2\mathbf{e}^2 + 2\mathbf{d} \cdot \mathbf{f} - \mathbf{f}^2 - 2\mathbf{d} \cdot \mathbf{g} - 2\mathbf{e} \cdot \mathbf{g} + 2\mathbf{f} \cdot \mathbf{g} - 2\mathbf{g}^2 + 2\mathbf{e} \cdot \mathbf{h} + 2\mathbf{g} \cdot \mathbf{h} - \mathbf{h}^2 \\ &\quad - 2\mathbf{a} \cdot \mathbf{s} + 4\mathbf{b} \cdot \mathbf{s} - 2\mathbf{c} \cdot \mathbf{s} + 4\mathbf{d} \cdot \mathbf{s} + 4\mathbf{e} \cdot \mathbf{s} - 2\mathbf{f} \cdot \mathbf{s} + 4\mathbf{g} \cdot \mathbf{s} - 2\mathbf{h} \cdot \mathbf{s} - 4\mathbf{s}^2. \end{aligned} \quad (5.6)$$

The first and second lines are the Abelian global anomaly while the last line is the (mixed) Abelian gauge anomaly. It is quite remarkable that the remaining Abelian gauge anomaly and Abelian global anomaly can be completely canceled by taking into account the additional tetravalent Fermi multiplets which are charged under the quadrant of D3-branes. They can give rise to anomaly contributions

$$\mathcal{I}^{\text{tetravalent Fermi}} = (\mathbf{a} + \mathbf{s} - \mathbf{b} - \mathbf{d})^2 + (\mathbf{b} + \mathbf{e} - \mathbf{c} - \mathbf{s})^2 + (\mathbf{d} + \mathbf{g} - \mathbf{s} - \mathbf{f})^2 + (\mathbf{s} + \mathbf{h} - \mathbf{e} - \mathbf{g})^2 \quad (5.7)$$

This beautifully cancels the anomaly polynomial (5.6) ! This anomaly computation strongly indicates that there are additional Fermi multiplets living at the NS5-NS5' intersection in the brane box configuration ⁶. As in Figure 19, the charges are equal on diagonal boxes and opposite on boxes which share a line. They will only couple to the Abelian parts of gauge and/or global symmetries for quadrant of D3-branes separated by NS5- and NS5'-branes.

For non-Abelian gauge and/or global symmetries, we can easily check that the Abelian part of the anomaly is cancelled under the balancing condition of equation (5.6) ⁷. In that case, the tetravalent Fermi multiplets is associated to the determinant representation of the gauge and/or global symmetries.

⁶ We thank D. Gaiotto as we have noticed this resolution in a discussion with him. As in our model, such Fermi multiplets living at the NS5-NS5' intersection is also considered in [38].

⁷This is compatible with the rule which is discussed in section 5.3.

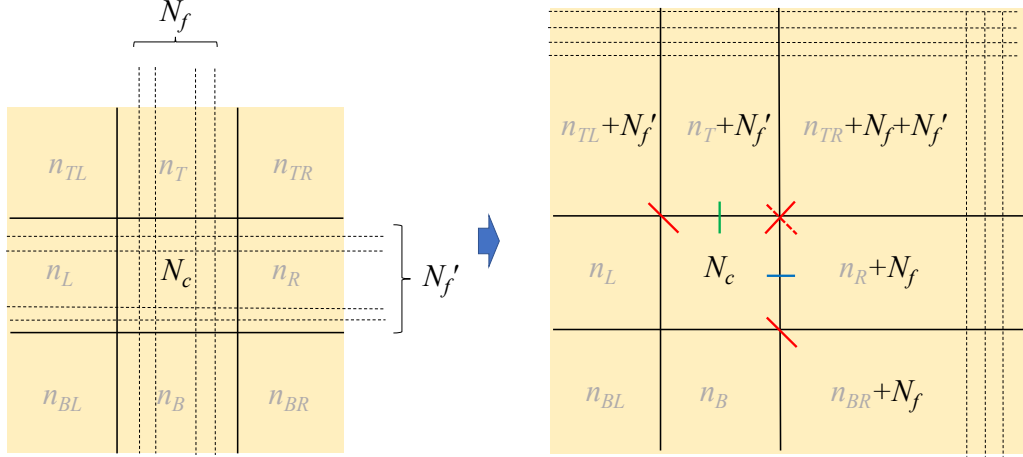

Figure 20: A creation of D3-branes when N_f D5- and N'_f D5' branes cross the right NS5-brane and the upper NS5'-branes. Additional N_f D3-branes are created in the adjacent boxes at the top-right, right and bottom right and additional N'_f D3-branes are created in the adjacent boxes at the top-right, right and bottom right.

5.2 Brane box with flavor 5-branes

Let us consider a non-periodic array of D3-brane boxes. For non-periodic brane box configuration a pair of linking numbers can be introduced. It is defined as the number of 5-branes of the opposite kind that are to the left (bottom) of the given 5-branes plus net number of D3-branes ending on the 5-brane from the right (top) minus the number ending from the left (bottom). It is important to note that the linking numbers can be read off for each segment of 5-branes.

To consider the effect of adding D5- and D5'-branes in the box configuration, we take a box of N_c D3-branes surrounded by two NS5-branes and two NS5'-branes which intersect with N_f D5-branes and N'_f D5'-branes (see Figure 20). By keeping the linking numbers of 5-branes, we rearrange 5-branes in such a way that all the D5-branes are located on the right and the D5'-branes are located on the top. The resulting configuration is illustrated in Figure 20.











Moving N_f vertical lines of D5-branes in the box to the right, additional N_f D3-branes are created in the adjacent boxes at the top-right, right and bottom right. Now we can read off matter multiplets from the edges between the N_c D3-branes and the N_f D3-branes which are created. Three types of new edges connecting to top-right, right and bottom-right boxes show up. These are N_f fundamental Fermi multiplets ξ , N_f fundamental $\mathcal{N} = (0, 4)$ hypermultiplets (H, \tilde{H}) and N_f fundamental Fermi multiplets $\tilde{\xi}$, respectively.

Similarly, moving N'_f horizontal D5'-branes to the top leads to N'_f D3-branes which are created in the adjacent boxes at the top-left, top, and top-right. Correspondingly, three types of edges give rise to N'_f fundamental Fermi multiplets ζ , N'_f fundamental $\mathcal{N} = (0, 4)$ twisted hypermultiplets (T, \tilde{T}) , and N'_f fundamental Fermi multiplets $\tilde{\zeta}$, respectively.

When N_f D5-branes and N'_f D5'-branes intersect in the central box of N_c D3 branes, neutral $N_f N'_f$ Fermi multiplets can be read off from dotted diagonal edge between the top box and the right box. They are coupled to N_f hypers and N'_f twisted hypermultiplets.

The above brane rearrangement supports the analysis of the T-dual brane configuration in subsec-

tion 4.2. In fact, the corresponding quiver diagram is again given in Figure 13. Therefore the quiver diagram of Figure 13 obtained from the computation from D1-D5-D5' brane system on $\mathbb{Z}_k \times \mathbb{Z}'_k$ can be also derived by the Hanany-Witten move in the non-periodic box model. We present a dictionary between the quiver and the brane box model as follows:

$\mathcal{N} = (0, 4)$ quiver	D3-brane box
$U(N)_{i,j}$ vector 	box (i, j) of N D3-branes
bi-fundamental hyper 	horizontal edge between box (i, j) and $(i \pm 1, j)$
bi-fundamental twisted hyper 	vertical edge between boxes (i, j) and $(i, j \pm 1)$
bi-fundamental Fermi 	diagonal edge between boxes (i, j) and $(i + 1, j - 1)$
bi-fundamental Fermi 	diagonal edge between boxes (i, j) and $(i - 1, j - 1)$
tetravalent Fermi 	NS5-NS5' junction
N_f fundamental hyper 	vertical dotted lines of N_f D5-branes
A pair of N_f fundamental Fermi 	
N'_f fundamental twisted hyper 	horizontal dotted lines of N'_f D5'-branes
A pair of N'_f fundamental Fermi 	
$N_f N'_f$ neutral Fermi 	intersecting points of N_f D5- and N'_f D5'-branes

(5.8)

5.3 2d-3d coupled system

Let us go back to the issue of $\mathcal{N} = (0, 4)$ boundary condition in section 3.3 and consider the 2d-3d coupled system realized in the brane box configuration.

As we have discussed, the boundary gauge anomaly must be cancelled and it is encoded by the linking numbers. Remembering that Neumann boundary condition for a gauge field is realized by NS5'-brane, we would like to require that

linking numbers of NS5'-branes defining the boundary should share the same linking numbers.

In addition to the above requirement, we further assume that

linking numbers of NS5'-branes defining the boundary is not larger than the numbers of D3-branes terminating on the boundary NS5'-brane.

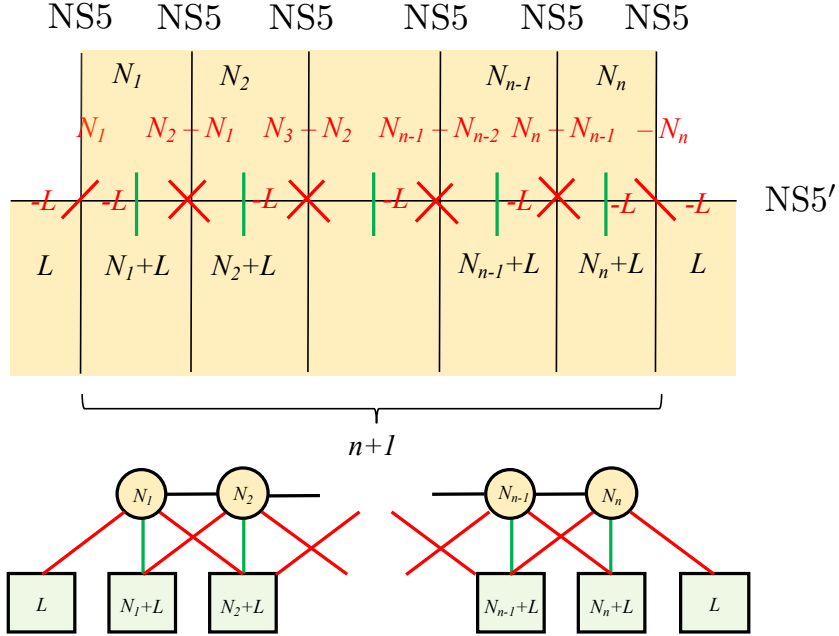

Figure 21: Brane construction of interface in 3d $\mathcal{N} = 4 \prod_{i=1}^n U(N_i)$ linear quiver gauge theory with bi-fundamental hypermultiplets. The numbers with red color indicate the linking numbers. The quiver diagram below illustrates the 2d-3d coupled system where the green and red edges are boundary twisted hyper and Fermi multiplets respectively.

This condition guarantees that the numbers of adjacent D3-branes are positive.

This suggests that the $\mathcal{N} = (0, 4)$ boundary conditions in 3d $\mathcal{N} = 4$ gauge theory can be labeled by the linking numbers of the boundary 5-branes. Now that we have a recipe to read off the $\mathcal{N} = (0, 4)$ matter content from the brane box configuration, we can determine what types of boundary degrees of freedom may appear in the boundary conditions for given linking numbers. It can be seen that the above simple requirement and our identification of matter multiplets consistently provides the appropriate boundary degrees of freedom which cancel the gauge anomaly.

Let us start with the brane construction of 3d $\mathcal{N} = 4 \prod_{i=1}^n U(N_i)$ linear quiver gauge theory with bi-fundamental hypermultiplets as in Figure 1. Using the above rules, we can choose a non-positive linking number $-L \leq 0$ for the NS5'-brane in each segment. These linking numbers can be realized when a certain set of D3-branes exist across the boundary NS5'-brane as shown in Figure 21.

Using the dictionary (5.8), we can read off the matter fields which couple to the 3d bulk gauge fields. For gauge nodes $U(N_i)$ with $i = 2, \dots, n-1$, there are $(N_i + L)$ $\mathcal{N} = (0, 4)$ fundamental twisted hypermultiplets and $(N_{i-1} + L) + (N_{i+1} + L)$ $\mathcal{N} = (0, 2)$ fundamental Fermi multiplets. Gauge nodes $U(N_1)$ and $U(N_n)$ are the ends of the quiver and the numbers of Fermi multiplets are smaller. For $U(N_1)$ the number of Fermi multiplets is $L + (N_2 + L)$, while for $U(N_n)$ the number of Fermi multiplets is $(N_{n-1} + L) + L$. Recalling (2.34), we find $\mathbf{f}_{\text{su}(N_i)}^2$ anomaly contributions from the 2d boundary fields

$$\begin{aligned}
\mathcal{I}_{\text{bdy}, L} &= (N_2 - 2N_1) \text{Tr}(\mathbf{s}_1^2) + \sum_{i=2}^{n-1} (-2N_i + N_{i-1} + N_{i+1}) \text{Tr}(\mathbf{s}_i^2) + (N_{n-1} - 2N_n) \text{Tr}(\mathbf{s}_n^2) \\
&= -\mathcal{I}_{(\mathcal{N}, N)}^{(N_1) - (N_2) - \dots - (N_n)}. \tag{5.9}
\end{aligned}$$

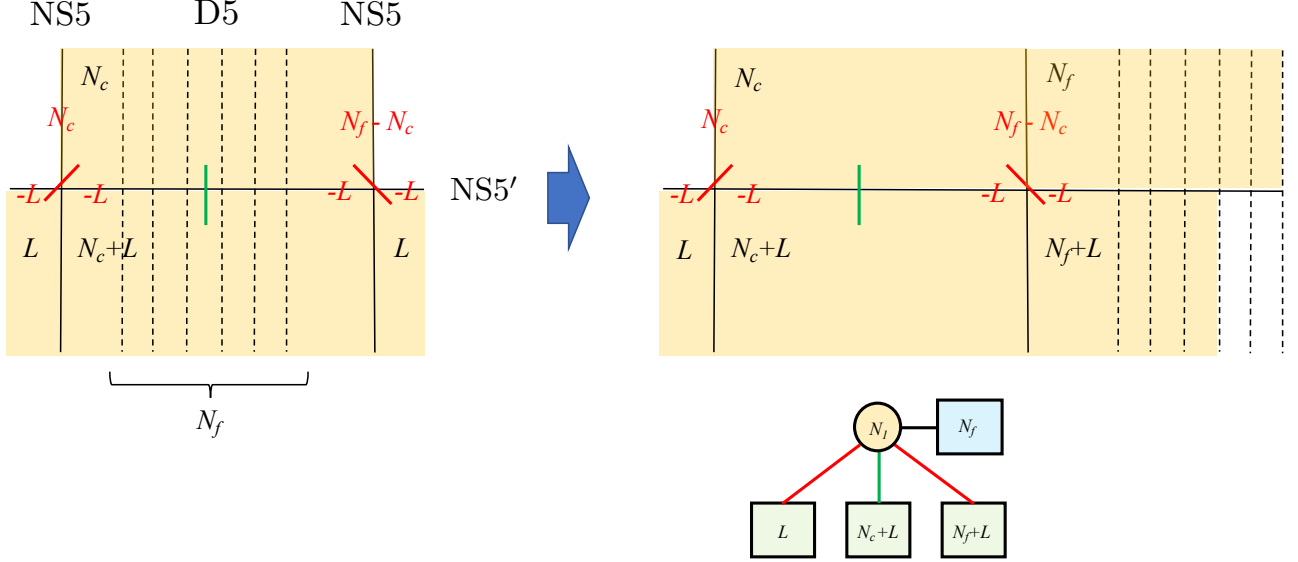

Figure 22: Brane construction of interface in 3d $\mathcal{N} = 4$ $U(N_c)$ gauge theory with N_f hypermultiplets. After the brane creation, the required Fermi multiplets for gauge anomaly cancellation can be read off from the diagonal edge.

This shows that the set of boundary fields determined by the linking number of the boundary 5-brane and the dictionary (5.8) consistently produces a gauge anomaly free boundary condition.

For 3d $\mathcal{N} = 4$ $U(N_c)$ gauge theory with N_f hypermultiplets, we have $\mathbf{f}_{\mathfrak{su}(N)}^2$ gauge anomaly (3.15). Making use of the rules above and rearranging the 5-branes, the boundary NS5'-brane with linking number $-L$ introduces $(N_c + L)$ twisted hypermultiplets and $L + (N_f + L)$ Fermi multiplets (see Figure 22). The $\mathbf{f}_{\mathfrak{su}(N)}^2$ anomaly contributions from these 2d boundary fields are given by

$$\begin{aligned} \mathcal{I}_{\text{bdy},L} &= (N_f - 2N_c) \text{Tr}(\mathbf{s}^2) \\ &= -\mathcal{I}_{(\mathcal{N},N)}^{(N_c) - [N_f]}. \end{aligned} \quad (5.10)$$

Again this demonstrates that the rules above and the dictionary (5.8) consistently leads to gauge anomaly free boundary conditions with appropriate boundary degrees of freedom.

We should note that the Abelian gauge anomaly again can be resolved by tetravalent Fermi multiplet living at the NS5-NS5' junction. Let us consider the simplest example of SQED with one hypermultiplet. The bulk hypermultiplet obeying the Neumann boundary condition has boundary $U(1)$ gauge anomaly. Taking $L = 0$ for the linking number of NS5'-brane and rearranging 5-branes, one can read off one charged twisted hypermultiplet as vertical edge, one charged Fermi multiplet as diagonal edge and tetravalent Fermi multiplet living at the NS5-NS5' junction from Figure 23.

We denote the field strengths for 3d gauge symmetry and 3d global symmetry by \mathbf{f} and \mathbf{a} . Also we let \mathbf{b} be the field strength for additional global symmetry under which the charged twisted hyper is charged and \mathbf{c} be the field strength for the other under which the charged Fermi is charged. The

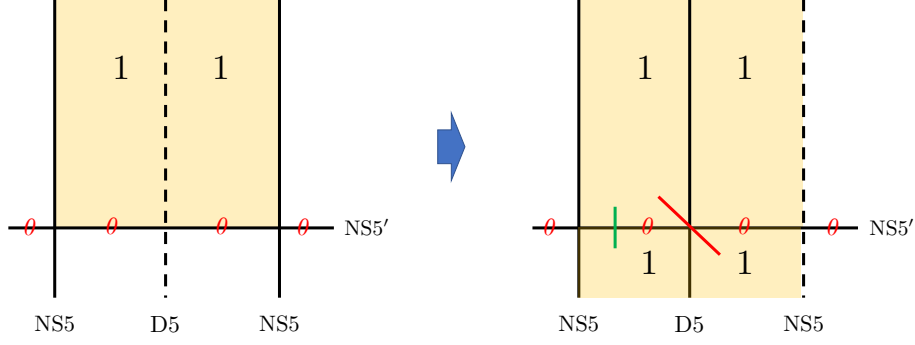

Figure 23: The Neumann boundary condition of linking number $L = 0$ for SQED with one hypermultiplet. The Abelian gauge anomaly is canceled by the tetravalent Fermi multiplets which live at the junction of NS5- and NS5'-branes.

anomaly polynomial which is contributed from charged fields is evaluated as

$$\begin{aligned}
\mathcal{I}_{\mathcal{N},N,L=0}^{\text{SQED}_1} &= \underbrace{-(\mathbf{f} - \mathbf{a})^2}_{\text{N b.c. of 3d hyper}} \underbrace{-2(\mathbf{f} - \mathbf{b})^2}_{(0,4) \text{ twisted hyper}} + \underbrace{(\mathbf{f} - \mathbf{c})^2}_{\text{Fermi}} + \underbrace{(\mathbf{b} - \mathbf{f})^2 + (\mathbf{f} + \mathbf{c} - \mathbf{a} - \mathbf{b})^2}_{\text{tetravalent Fermi}} \\
&= 2\mathbf{c}^2 - 2\mathbf{a} \cdot \mathbf{b} - 2\mathbf{a} \cdot \mathbf{c} - 2\mathbf{b} \cdot \mathbf{c}
\end{aligned} \tag{5.11}$$

This shows that the boundary condition (\mathcal{N}, N) with linking number $L = 0$ for SQED with one hypermultiplet is free from gauge anomaly. The remaining global anomaly is beautifully resolved by further taking into account the anomaly contributions from 3d hyper and twisted hypermultiplets which live across the boundary with the Neumann boundary condition and the uncharged boundary Fermi multiplet which can be read off from vertical, horizontal and diagonal edges respectively:

$$\begin{aligned}
\mathcal{I}_{\text{bdy},L=0} &= \underbrace{-(\mathbf{b} - \mathbf{c})^2}_{\text{N b.c. of 3d hyper}} \underbrace{-(\mathbf{c} - \mathbf{a})^2}_{\text{N b.c. of 3d twisted hyper}} + \underbrace{(\mathbf{a} - \mathbf{b})^2}_{\text{neutral Fermi multiplet}} \\
&= -\mathcal{I}_{\mathcal{N},N,L=0}^{\text{SQED}_1}.
\end{aligned} \tag{5.12}$$

Acknowledgements

We would like to thank Sebastian Franco, Davide Gaiotto, Rak-Kyeong Seong and Junya Yagi for useful discussions and comments. A.H. is supported by STFC Consolidated Grant ST/J0003533/1, and EPSRC Programme Grant EP/K034456/1. T.O. is supported in part by Perimeter Institute for Theoretical Physics and JSPS Overseas Research fellowships.

References

- [1] E. Witten, “Sigma models and the ADHM construction of instantons,” *J. Geom. Phys.* **15** (1995) 215–226, [hep-th/9410052](#).
- [2] S. J. Gates, Jr. and L. Rana, “Manifest (4,0) supersymmetry, sigma models and the ADHM instanton construction,” *Phys. Lett.* **B345** (1995) 233–241, [hep-th/9411091](#).

- [3] A. Galperin and E. Sokatchev, “Manifest supersymmetry and the ADHM construction of instantons,” *Nucl. Phys.* **B452** (1995) 431–455, [hep-th/9412032](#).
- [4] A. Galperin and E. Sokatchev, “Supersymmetric sigma models and the ’t Hooft instantons,” *Class. Quant. Grav.* **13** (1996) 161–170, [hep-th/9504124](#).
- [5] N. D. Lambert, “Quantizing the (0,4) supersymmetric ADHM sigma model,” *Nucl. Phys.* **B460** (1996) 221–232, [hep-th/9508039](#).
- [6] P. Putrov, J. Song, and W. Yan, “(0, 4) dualities,” [1505.07110](#).
- [7] A. Gadde, B. Haghighat, J. Kim, S. Kim, G. Lockhart, and C. Vafa, “6d String Chains,” *JHEP* **02** (2018) 143, [1504.04614](#).
- [8] J. M. Maldacena, A. Strominger, and E. Witten, “Black hole entropy in M theory,” *JHEP* **12** (1997) 002, [hep-th/9711053](#).
- [9] R. Minasian, G. W. Moore, and D. Tsimpis, “Calabi-Yau black holes and (0,4) sigma models,” *Commun. Math. Phys.* **209** (2000) 325–352, [hep-th/9904217](#).
- [10] Y. Sugawara, “ $N = (0,4)$ quiver SCFT₂ and supergravity on $AdS_3 \times S^2$,” *JHEP* **06** (1999) 035, [hep-th/9903120](#).
- [11] K. Okuyama, “D1-D5 on ALE space,” *JHEP* **12** (2005) 042, [hep-th/0510195](#).
- [12] P. M. Cowdall and P. K. Townsend, “Gauged supergravity vacua from intersecting branes,” *Phys. Lett.* **B429** (1998) 281–288, [hep-th/9801165](#). [Erratum: *Phys. Lett.* B434,458(1998)].
- [13] H. J. Boonstra, B. Peeters, and K. Skenderis, “Brane intersections, anti-de Sitter space-times and dual superconformal theories,” *Nucl. Phys.* **B533** (1998) 127–162, [hep-th/9803231](#).
- [14] J. P. Gauntlett, R. C. Myers, and P. K. Townsend, “Supersymmetry of rotating branes,” *Phys. Rev.* **D59** (1998) 025001, [hep-th/9809065](#).
- [15] D. Tong, “The holographic dual of $AdS_3 \times S^3 \times S^3 \times S^1$,” *JHEP* **04** (2014) 193, [1402.5135](#).
- [16] H.-J. Chung and T. Okazaki, “(2,2) and (0,4) Supersymmetric Boundary Conditions in 3d $N = 4$ Theories and Type IIB Branes,” *Phys. Rev.* **D96** (2017), no. 8 086005, [1608.05363](#).
- [17] A. Hanany and E. Witten, “Type IIB superstrings, BPS monopoles, and three-dimensional gauge dynamics,” *Nucl.Phys.* **B492** (1997) 152–190, [hep-th/9611230](#).
- [18] M. R. Douglas and G. W. Moore, “D-branes, quivers, and ALE instantons,” [hep-th/9603167](#).
- [19] J. Wess and J. Bagger, *Supersymmetry and supergravity*. 1992.
- [20] E. Witten, “Phases of $N=2$ theories in two-dimensions,” *Nucl.Phys.* **B403** (1993) 159–222, [hep-th/9301042](#).
- [21] A. Adams, A. Basu, and S. Sethi, “(0,2) duality,” *Adv. Theor. Math. Phys.* **7** (2003), no. 5 865–950, [hep-th/0309226](#).
- [22] T. Okazaki and S. Yamaguchi, “Supersymmetric boundary conditions in three-dimensional $N=2$ theories,” *Phys.Rev.* **D87** (2013), no. 12 125005, [1302.6593](#).

- [23] A. Gadde, S. Gukov, and P. Putrov, “Fivebranes and 4-manifolds,” 1306.4320.
- [24] T. Dimofte, D. Gaiotto, and N. M. Paquette, “Dual Boundary Conditions in 3d SCFT’s,” 1712.07654.
- [25] N. P. Warner, “Supersymmetry in boundary integrable models,” *Nucl. Phys.* **B450** (1995) 663–694, hep-th/9506064.
- [26] C. G. Callan and J. M. Maldacena, “Brane death and dynamics from the Born-Infeld action,” *Nucl. Phys.* **B513** (1998) 198–212, hep-th/9708147.
- [27] N. R. Constable, R. C. Myers, and O. Tafjord, “The Noncommutative bion core,” *Phys. Rev.* **D61** (2000) 106009, hep-th/9911136.
- [28] A. Hanany and A. M. Uranga, “Brane boxes and branes on singularities,” *JHEP* **05** (1998) 013, hep-th/9805139.
- [29] S. Franco, D. Ghim, S. Lee, R.-K. Seong, and D. Yokoyama, “2d (0,2) Quiver Gauge Theories and D-Branes,” 1506.03818.
- [30] S. Gukov, E. Martinec, G. W. Moore, and A. Strominger, “The Search for a holographic dual to $AdS_3 \times S^3 \times S^3 \times S^1$,” *Adv. Theor. Math. Phys.* **9** (2005) 435–525, hep-th/0403090. [1519(2004)].
- [31] T. Banks, N. Seiberg, and E. Silverstein, “Zero and one-dimensional probes with N=8 supersymmetry,” *Phys. Lett.* **B401** (1997) 30–37, hep-th/9703052.
- [32] C. P. Bachas, M. B. Green, and A. Schwimmer, “(8,0) quantum mechanics and symmetry enhancement in type I’ superstrings,” *JHEP* **01** (1998) 006, hep-th/9712086.
- [33] K. Behrndt, I. Brunner, and I. Gaida, “AdS(3) gravity and conformal field theories,” *Nucl. Phys.* **B546** (1999) 65–95, hep-th/9806195.
- [34] D. Kutasov, F. Larsen, and R. G. Leigh, “String theory in magnetic monopole backgrounds,” *Nucl. Phys.* **B550** (1999) 183–213, hep-th/9812027.
- [35] D. Berenstein and R. G. Leigh, “String junctions and bound states of intersecting branes,” *Phys. Rev.* **D60** (1999) 026005, hep-th/9812142.
- [36] I. Bena and P. Kraus, “Microstates of the D1-D5-KK system,” *Phys. Rev.* **D72** (2005) 025007, hep-th/0503053.
- [37] B. Haghighat, C. Kozcaz, G. Lockhart, and C. Vafa, “Orbifolds of M-strings,” *Phys. Rev.* **D89** (2014), no. 4 046003, 1310.1185.
- [38] K. Costello and D. Gaiotto, “Vertex Operator Algebras and 3d N=4 gauge theories,” 1804.06460.