

Building and Evaluation of a Real Room Impulse Response Dataset

Igor Szoke, *Member, IEEE*, Miroslav Skácel, Ladislav Mošner, *Student Member, IEEE*, Jakub Paliesek, and Jan “Honza” Černocký, *Senior member, IEEE*

Abstract—This paper presents BUT ReverbDB - a dataset of real room impulse responses (RIR), background noises and re-transmitted speech data. The retransmitted data includes LibriSpeech test-clean, 2000 HUB5 English evaluation and part of 2010 NIST Speaker Recognition Evaluation datasets. We provide detailed description of RIR collection (hardware, software, post-processing) that can serve as a “cook-book” for similar efforts. We also validate BUT ReverbDB in two sets of automatic speech recognition (ASR) experiments and draw conclusions for augmenting ASR training data with real and artificially generated RIRs. We show that a limited number of real RIRs, carefully selected to match the target environment, provide results comparable to a large number of artificially generated RIRs, and that both sets can be combined to achieve the best ASR results. The dataset is distributed for free under a non-restrictive license, currently contains data from 8 rooms and is growing. The distribution package also contains a Kaldi-based recipe for augmenting publicly available AMI close-talk meeting data and test the results on AMI single distant microphone set, allowing to reproduce our experiments.

Index Terms—far-field, automatic speech recognition, room impulse response, reverberation, SineSweep, Maximum Length Sequence, noise, deep neural network, Kaldi, AMI.

I. INTRODUCTION

AUTOMATIC speech recognition (ASR) has made tremendous improvement in the last decade and services and applications making use of close-talk speech (such as SMS dictation, personal assistants, or contact-center speech data analytics) are on the market and serving millions of customers. On the other hand, ASR from far-field microphones is far less advanced and significant research efforts are devoted to improve its performance and robustness.

Despite all the research efforts, the best one can do to obtain a decent ASR performance is to collect transcribed data from the target domain. For far-field ASR, however, this is unfeasible due to infinity of different room configurations, microphone placements, microphone types, noise conditions, etc. *Data augmentation* — reverberation of source data using estimated or artificially generated room impulse responses (RIR) and adding real noises to simulate the environment — is therefore the most common technique to build a robust ASR [1] nowadays.

The work was supported by Czech Ministry of Interior project No. VI20152020025 “DRAPAK”, Google Faculty Research Award program, Czech Science Foundation under project No. GJ17-23870Y, and by Czech Ministry of Education, Youth and Sports from the National Programme of Sustainability (NPU II) project “IT4Innovations excellence in science - LQ1602”. We would like to thank Kamil Chalupníček and Ondřej Novotný for helping us to collect the BUT ReverbDB.

Gathering noises is easy as there are lots of public sources and the noises can be also extracted from existing speech data. On the other hand, gathering real RIRs is technically difficult and time demanding. To overcome this problem, artificial RIRs are usually used as they can be generated automatically and in large quantities. They are good enough in scenarios, where the speaker and microphone are facing each other, but simulating RIRs for microphones partly or fully hidden is not solved yet. Here, the estimation of real impulse responses is the only way.

Also, there is lack of “parallel audio corpora” where both clean close-talk (ideally anechoic) speech is available together with reverberated and noised version in various environments. This parallel corpus may be useful also in scenarios as audio enhancement, denoising, dereverberation or beam-forming.

A. Motivation and goals

The motivation of this paper is to: a) introduce the Brno University of Technology Speech@FIT Reverberation Database (**BUT ReverbDB**) and describe the methodology of its collection, b) compare the impact of data augmentation using either artificial or real impulse responses in scenarios with no target training data available for the development of an ASR system. BUT ReverbDB contains also data for developing and testing of far-field Speaker REcognition (SRE) systems, but this paper concentrates solely on ASR.

The BUT ReverbDB is being built in order to collect large number of various RIRs, room environmental noises (or “silences”), retransmitted speech (for ASR and SRE testing), and meta-data (positions of microphones, speakers etc.). The goal is to provide speech community with a dataset for data augmentation and distant microphone or microphone array experiments in ASR and SRE. The database is distributed under Apache 2.0 license (free for commercial, academic, and government use) and is available at BUT web pages¹.

So far, BUT ReverbDB contains data from 8 rooms (large, middle and small size). We placed 31 microphones in each room. The speaker source was usually placed on 5 different positions per room. We measured room impulse responses, environmental noise (silence) and we retransmitted **LibriSpeech Test-clean** dataset [2], **2000 HUB5 English evaluation** set² and also part of **NIST Speaker Recognition Evaluation 2010** dataset [3] (the availability of the HUB5 and SRE data is limited to sites that have valid LDC license to the original data).

¹<https://speech.fit.vutbr.cz/software/but-speech-fit-reverb-database>

²<https://catalog.ldc.upenn.edu/LDC2002S09>

All speaker and microphone positions are measured and stored in meta-files in Cartesian and polar coordinates, and in absolute and relative (to the speaker) way.

BUT is taking part in “DRAPAK” project sponsored by the Czech Ministry of Interior concentrating on ASR and SRE in security domain (including close-talk and distant microphones, listening devices, etc.), therefore, the motivation of BUT ReverbDB is to collect acoustic environments which are challenging and cannot be easily simulated. That’s also why our microphones are partly placed in very unusual places.

A number of ASR experiments were performed with BUT ReverbDB — partly as sanity check and partly to show the importance of real environment impulse responses and background noises for training data augmentation.

B. Organization of the paper

The paper is organized as follows: the following Section II presents related work in distant microphone ASR, existing RIR data-sets and their shortcomings. Section III summarizes approaches to estimation of real and synthetic RIRs. Section IV is the core of the paper and contains the details of BUT ReverbDB collection including a handful of practical details. Section V describes the first ASR experiments performed on Czech language aimed to validate the data-set. Section VI presents work on AMI data – these experiments are fully reproducible as all RIRs, data and recipes are made available. Section VII concludes the paper and outlines future work.

II. RELATED WORK

A. Automatic speech recognition on reverberated data

ASR performance heavily degrades when facing mismatch between training and evaluation data conditions [4]. Such mismatch can include the environment (background noise, recording conditions (microphones and rooms)) and speaker characteristics (calm speech versus shouting with Lombard effect). An obvious solution is to collect and transcribe data from target domain. However, when ASR is used in the field, the time, effort, and cost of transcribing data for the new conditions becomes limited (as in IARPA’s BABEL³ and DARPA’s LORELEI⁴ projects) or prohibitive (ASpIRE challenge [5]).

Changes in room acoustics can be a significant source of mismatch (and hence ASR word accuracy drop) as was shown on International Computer Science Institute (ICSI) meeting room dataset [6], [7], Augmented Multi-party Interaction (AMI) meeting room corpus [8], and the Multi-channel Wall Street Journal Audio Visual Corpus (MC-WSJ-AV) corpus [9].

The ASpIRE challenge [5] addressed far-field microphone recordings of conversational speech with very large vocabulary. The test data differed substantially from training and development data. The ASpIRE challenge demonstrated that working continually on the same test data and making progress on that data may not guarantee robustness to data collected

in new (although related) recording conditions. Reverberation was clearly important in both the development and evaluation sets; however, microphone variability was greater in development set (Mixer 6 [10]) and room variability in evaluation set (Mixer 8). This suggests that new challenges that aim to measure system robustness need to creatively collect new test data with mismatch and then limit testing on these data until after systems are developed.

An interesting analysis of ASpIRE results [11] studied correlation of source-to-microphone distance and ASR performance, and concluded that rather than trying to extrapolate ASR performance from simple distance metrics, one needs to take into account also the orientation of both the speaker and the microphone. This means that we do need not only data with microphones facing directly the speaker, but also other, more complicated, speaker-microphone positions.

Another paper by Ko [12] based on ASpIRE and AMI data pointed out, that the performance gap between using simulated and real RIRs can be eliminated when point-source noises are added. For Ko, the trained acoustic model not only performed well in the far-field scenario but also provided better results in the close-talking one.

The problem of robustness of ASR on distant microphones was also approached by a series of CHiME challenges. CHiME-1 [13] aimed at small vocabulary ASR (command and control) in a real living room using binaural microphones. Target speech commands were mixed into the environment noises at a fixed position using genuine room impulse responses. CHiME-2 [14] used the CHiME-1 dataset and aimed at a larger vocabulary and a more realistic mixing process accounting for small head movements while speaking. CHiME-3 [15] and CHiME-4 are designed around the popular Wall Street Journal (WSJ) corpus and feature talkers speaking in challenging noisy environments recorded using a 6-channel tablet-based microphone array. They consist of two types of data 1) “Real data” – read speech data recorded in real noisy environments (on a bus, cafe, pedestrian area, and street junction) uttered by actual talkers, 2) “Simulated data” – noisy utterances generated by artificially mixing clean speech data with noisy backgrounds. Actually, CHiME-5 Challenge [16] aims to be the first large-scale corpus of real multi-speaker conversational speech recorded via commercially available multi-microphone hardware (Kinect and binaural microphones) in multiple homes. Speech material was gathered from 4-people dinner party scenario in 20 homes. However, no RIRs were collected in any CHiME data collections.

In REVERB challenge [17], the goal was to evaluate different approaches to ASR and speech enhancement on simulated data (WSJ artificially reverberated and noised by real world RIRs and noises) and real data (WSJ utterances read by humans in real noisy and reverberant conditions). The conclusion of the REVERB challenge [18] was “Apart from the problems of ASR techniques, concerning the data preparation stage, challenges remain in simulating acoustic data that are close to actual recordings. Developing better simulation techniques remains another important research direction since simulations can be useful to evaluate techniques and generate relevant training data for acoustic model training.”

³<https://www.iarpa.gov/index.php/research-programs/babel>

⁴<https://www.darpa.mil/program/low-resource-languages-for-emergent-incidents>

The results of Ravanelli [19] show, that using real RIRs to augment the training data provides significant improvement on ASR Word Error Rate (WER) (using a recent deep neural network system) to the data augmentation using just artificial RIR even with setting the room parameters as close as possible to the real room.

B. Available room impulse responses sets

BUT ReverbDB is not the first RIR set. The following sets are known to us:

- Aachen Impulse Response⁵ (AIR) [20] database contains 214 RIRS (6 types of room, with several configurations of microphone/source placing).
- RWCP Sound Scene Database⁶ [21] contains over 3000 impulse responses for a circular and linear microphone array placed in 9 rooms (with several positions of the speaker), speech data recorded with the same array, and recordings of background noises.
- REVERB challenge⁷ [17] dataset contains 24 RIRs (2 times 3 types of room, near and distant microphone placement, 2 microphone angles).
- Open AIR Library⁸ database contains hundreds of environments but a few impulse responses (IRs) are available from real and standard rooms.
- DIRHA project⁹ [22] dataset is composed of real phonetically-rich sentences recorded with 32 sample-synchronized microphones in a domestic environment (4 rooms).
- VoiceHome [23] corpus aimed at command and control scenario (smart home) includes reverberated, noisy speech signals spoken by 12 native French talkers in 4 houses (3 rooms per house) and recorded by an 8-microphone device at various angles and distances and in various noise conditions. According to the paper, 188 RIRs were collected, however, they are not part of the corpus release.
- Sweet-Home [24] corpus also aimed at command and control scenario (smart home). It consists of 26 hours of speech data (French) recorded in 4 rooms (1 flat), 7 channels (2+2+2+1). No RIRs were recorded.
- The ACE Corpus¹⁰ [25] consists of 700 RIRs (50 microphones in 6 devices, placed in 2 setups in 7 rooms) and was used in ACE challenge [26] (estimation of T_{60} and Direct-to-Reverberant Ratio). The recording devices are mobile phone, notebook and also 32-channel spherical microphone array.

To conclude, a large data set of RIRs with consistent recording protocols covering standard acoustic environments like offices, houses, corridors etc., is missing. The closest RIR dataset is the ACE Corpus. Some of the actual datasets contain

RIRs simulating binaural hearing (using dummy-head). Others are aimed for smart home scenarios. This is however not our goal as our target application is speech data mining (ASR and SRE) from a variety of sources (table top microphones, IoTs, mobile devices, smart assistants, smart homes, but also listening devices, bugs and other non-standard microphones) in a variety of positions.

III. OBTAINING ROOM IMPULSE RESPONSES

A RIR can be obtained in two principal ways: the first is to measure the environment and obtain the “real” RIR, the second is to synthetically generate it artificially.

A. Real room impulse responses

Several methods were developed to measure the real RIR. The Maximum Length Sequence (MLS) technique was first proposed by Schroeder [27]. Other techniques were suggested to reduce distortion artifacts of MLS such as the Inverse Repeated Sequence (IRS) [28]. Another method – Time-Stretched Pulses – was proposed by Aoshima [29]. Finally, a logarithmic SineSweep technique introduced by Farina [30] should overcome some limitation of the other ones.

Stan et al. compared available RIR measurement techniques in [31] with the following conclusions:

- *Maximum Length Sequence* is the most interesting when we have to measure Impulse Response (IR) of an occupied room or exterior setting. The method has strong immunity to all kinds of noise (either white or impulsive). On the other hand, the major drawback is in appearance of “distortion peaks” due to the inherent non-linearities of the measurement system. They can be avoided by precise calibration (mainly the output level). MLS also expects input/output sampling clock synchronization [30].
- *Time-Stretched Pulses* do not produce distortion peaks. However, the remaining non-linear artifacts can occur in the de-convolved IR and it is not possible to remove them. This method cannot be used in occupied rooms.
- *SineSweep (SS)* method is perfect in rejecting the harmonic distortions prior to the “linear” impulse response estimation. It has excellent signal-to-noise ratio and is perfect for quiet rooms. It also does not need output level calibration. On contrary to MLS, it is not well suited for noisy environments.

According to [32], the Exponential SineSweep (ESS) has shown robustness to changing speaker output level while MLS and LSS (Linear Sine Sweep) tend to degrade the ASR WER in presence of higher output volumes. ESS was also found robust (only 0.5% WER deterioration) when switching from expensive studio monitors to cheap PC speakers.

The best method for our needs is the Exponential Sine Sweep [33] as it is not sensitive to output level calibration and we will use it in empty environments (non-occupied rooms). We accompany the ESS measurements with MLS to have the RIR in cases, where a microphone is placed close to a noise source and the SNR is low for this particular microphone. Also, our hardware setup (see section IV-A) does not have clock signal synchronization between playback and

⁵https://www.iks.rwth-aachen.de/fileadmin/user_upload/downloads/forschung/tools-downloads/air_database_release_1_4.zip

⁶ <http://research.nii.ac.jp/src/en/RWCP-SSD.html>

⁷<https://catalog ldc.upenn.edu/LDC95S24>

⁸<http://www.openairlib.net>

⁹<http://dirha.fbk.eu/English-PHdev>

¹⁰<https://acecorpus.ee.ic.ac.uk/>

recording device which limits the use of MLS. However, we were able to compensate this by re-sampling of the recorded MLS signal (see section V-A). We use MLS implementation by Thomas [34] and ESS implementation available as a free Matlab code¹¹.

B. Artificial room impulse responses

Image Source Method (ISM) is a way to generate a RIR artificially. The approach was formulated by Allen [35] and uses “unwrapping” of room geometry. Every reflection of the sound beam from a wall can be considered as a sound beam originating from a virtual source behind the wall. The sound beam energy is reduced by the wall reflection coefficient (absorption). Using this principle, the room geometry is unfolded several hundred or thousand times and appropriate virtual sound sources are placed in the space. The final RIR is a summation of delayed Dirac impulses passed through a low-pass filter (to respect the sampling theorem) and attenuated by appropriate number of “walls” it has to reflect of.

We use the artificial RIR generator implemented by Habets [36]. It allows to set reflection coefficients of particular walls, and orientation and characteristics of microphones. It uses omni directional speaker.

IV. MEASURING RIRS IN BUT REVERBDB

A. Hardware

1) *Audio recording*: Our requirements on recorded audio are large amount of channels in high quality and sample-to-sample synchronization across all channels (see section III) at reasonable price¹². We decided to design our own hardware with the help of colleagues from Audified¹³. The device is based on Analog Devices development board SC589 equipped with ARM Cortex A5 processor and Sharc DSP processor. The processor board is connected to two 16-channel boards equipped with 96kHz, 24bit, AKM A/D converters with software driven gains and phantom power.

Sampled audio data are assembled in TCP/IP packets (interleaving format with timestamps) and sent through Ethernet to a server. Here, the 32 channels are reconstructed and stored on hard-drive as 32 PCM audio files. Any packet drop-outs are reported to a log file.

2) *Audio playback*: We use an external USB stereo soundcard with symmetrical outputs. We played our audio data in the left channel together with a control signal played in the right channel (see section IV-C1 and figure 3 for details). The control signal is recorded as channel 32 on the recording device. The left channel is fed to the speaker – Adam audio A7X studio monitor¹⁴. The speaker is placed on a wheeled stand with settable height (see figure 1).

¹¹<http://freesourcecode.net/matlabprojects/69639/exp.sweep-and-impulse-response-in-matlab>

¹²We are aware of AVS or other hi-end solutions with master/slave clock bus etc., but these were unacceptable for our budget.

¹³<http://www.audified.com>

¹⁴RMS: 100W, Frequency response: 42Hz – 50kHz, Crossover frequency: 2.5Hz, Size: 337mm x 201mm x 280mm, Weight: 9.2kg, Bass reflex in front. <http://www.adam-audio.com/en/pro-audio/products/a7x/description>



Fig. 1. Movable (wheeled) stand for placing the speaker (A7X) in the room. The height of the speaker is adjustable. It is also used as cable holder and equipment table when moving from room to room.

The speaker is placed in the following positions in each room:

- *Sitting speaker*: Usually in front of a computer monitor or a table simulating a sitting person (about 140cm above the floor).
- *Standing speaker*: Placed randomly in the room where a person can stay (about 170cm above the floor).
- *Noise source*: Simulates position of a source of noise, for example a radio, air-condition (AC), fan, etc. The reasoning is to collect RIR of noise source and then generate “real” noises by, for example, reverberating an FM radio audio stream using this RIR.
- *Non-standard position*: Directed to the ceiling, or floor, lying on the floor etc.

3) *Noise sources*: Most of environments are without any additional noise source. The real noises include AC, vents, or common street noise coming through windows. We added artificial noise sources in a few recording sessions. This is marked in the meta-data. We use Tecsun PL-680 radio receiver tuned to a random local FM station as another source of noise. This noise source is placed at usual radio positions in the room.

B. Microphones

We use two types of microphone capsules, both with symmetrical wiring and phantom-powered:

- *standard microphone capsule* (a majority of our microphones) includes an omnidirectional electret condenser microphone module – PMOF-6027PN-42UQ.
- *Sennheiser MKE 2* omnidirectional microphone.

They are placed in several mountings:

1) *Spherical array mounting*: To cover a microphone array use-case, we made a spherical 8-channel array. It consists of 8 *standard microphone capsules* placed in a 8cm diameter



Fig. 2. Photo of a small (left) and big (right) IoT mounting. Each contains one standard microphone capsule.

sphere on two parallel planes (4 per each). Microphones are placed in square vertices. The two vertices are rotated by 45° . The orientation of the microphones is from the sphere center. This microphone mounting is usually placed where a similar device (a smart home assistant) is expected in the room.

2) *Internet-of-Things mounting*: We mounted two standard microphone capsules into plastic boxes with magnets glued on. These devices are usually attached to a wall or some metal object mounted on a wall, see figure 2.

3) *Stand mounting*: 6 to 10 microphones are mounted on a stand. These are then placed on floor, table, etc. and adjusted to desired microphone position and direction. Some of the microphones are also mounted to a computer monitor, lamp, and other objects simulating table-top microphones.

4) *Laid mounting*: 5 to 10 microphones are just laid on a chair, table, cupboard, shelf, etc. The microphone is usually oriented approximately towards the sound source.

5) *Hidden laid mounting*: Some of the laid microphones are partly or fully hidden in an object. This simulates placing of “bugs” and listening devices. The place is described in the particular microphone placement meta-data. We hid the microphone in a shelf, drawer, waste bin, flower, vent or behind painting, white board, etc.

6) *In-air mounting*: About 5 microphones are placed in the air close to the ceiling. Here, we use fishing rods to place the microphones to the upper corners, close to various sensors (smoke detectors), lights, projectors, etc. We also let one or two microphones just hang down and be in the space far from any obstacles.

C. Software

1) *Playback data preparation*: Playback data preparation is done once per dataset. All files are up-sampled to 44.1kHz, 16bit per sample, mono, and concatenated into longer files (about 1 hour) interleaved with about 0.5s of silence (zeros). The length of silence is adjusted to exactly fill the control signal. This is the left audio playback channel (see figure 3).

In parallel, we generate a control signal for the right audio playback channel, consisting of two sine signals: one with a low frequency and small magnitude, the other with a high frequency and large magnitude. The low frequency sine is used when the audio from dataset is present in the left channel, the high frequency one is used for parts of the inserted silence.

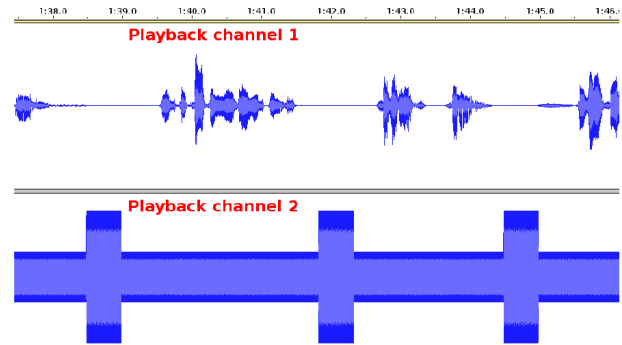

Fig. 3. Example of playback audio signals. Left channel contains concatenated audio for retransmission with inserted 0.5s long silences. Control signal in the right channel consists of two sines with different magnitudes and frequencies.

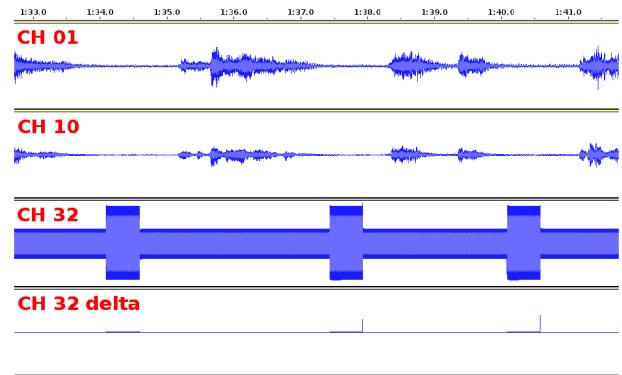

Fig. 4. Example of recorded data. Channels 1, 10, 32 and delta of 32.

The low-to-high frequency and high-to-low frequency sine transitions are synchronized with full sine periods to avoid discontinuities in time and to minimize the delta between consecutive samples (see figure 5).

2) *Recorded data post-processing*: Recorded audio (32 channels sample-to-sample synchronized) is stored as 32 separate wav files (see an example in figure 4). First, we detect possible problems, then we split the long raw recordings back to the retransmitted audio corpus (parallel corpus). We use the recorded sine signal in channel 32 for both steps. In case of errors (caused by playback buffer under-run, samples drop, packet loss, etc.), the sine signal in channel 32 is corrupted. This can be easily detected by computing delta and double-delta signal of channel 32, and by applying a simple peak detection.

To split the long audio back to particular files, we use the change in magnitude and frequency of the sines. As the change of frequency happens at the beginning of sine period, discontinuities are minimized (see figure 5). So, we can find the beginning of a particular audio file with sample precision. We also use the inserted silences as a room for delays caused by room acoustics. To shift the recorded audio back (compensate for the sound velocity), we can use the distance of particular microphone to the speaker. However we found out this technique not precise enough so we ended up in a simple RIR energy detector with a safe margin of 100 samples. More on compensating the RIR shifts in section VI-E.

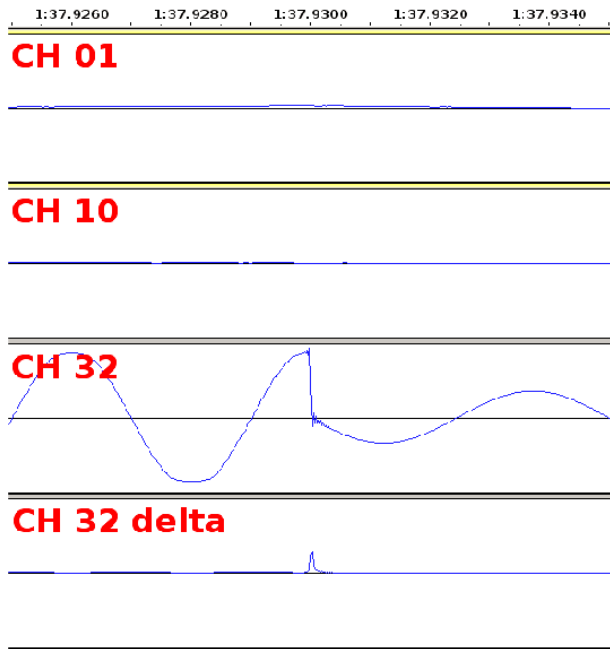

Fig. 5. Example of recorded data with an error. Channels 1, 10, 32 and delta of 32. Notice the discontinuity in channel 32. This can be easily detected as a peak in delta of channel 32.

D. Meta-data

We generate a lot of meta-data to provide details on: 1) the room (environment), 2) speaker placing(s), 3) microphones placings. The meta-data is available in text files. We provide several coordinate systems allowing for easy work with our data set. We use absolute and relative Cartesian (depth, width, height) and spherical (distance, azimuth, elevation) coordinates for microphone and speaker positions. We use azimuth and elevation for microphone or speaker orientation.

We assume the room has a block shape. The right hand, bottom, rear corner (after entering the room) is defined as the origin (0, 0, 0) for *absolute measurements*. We measure *Depth* – Back to front, *Width* – Right to left, and *Height* – Bottom to top from this origin. If the room has an “L” shape, we split it to two blocks. We measure angles clock-wise. So +90 degrees is on your right hand (azimuth) and above your head (elevation).

The origin for *relative measurements* is the placement of the speaker (speech source). Microphone to speaker distance can therefore be easily obtained by looking to the relative distance of the microphone. In addition to the size of the room, we store photos, description, type, size, temperature, materials, amount of furniture, and background noise level.

We can place several microphone setups in every room (denoted by `MicSetupID` in meta-data), however we use mainly just one microphone setup per room.

On the other hand, we usually place the speaker(s) in several positions (`SpkSetupID`) for every microphone setup. Here, we try to have at least five distinct positions. The first position of the speaker is the one we use for measuring the coordinates of all microphones and their meta-data. One speaker setup can consist of one or more physical speakers. The first

speaker is always the one playing the audio (speech data, sine sweeps, MLS, etc.). The others may be used as noise sources (radio in the background etc.). We store coordinates (position), orientation (facing), and the type of the speaker as meta-data for each speaker.

E. Status of BUT ReverbDB

We measured 8 rooms with majority of data processed, exported and made available. The available rooms are summarized in table I. The volume is an approximation for non-block shape rooms. The number of RIRs is given by the number of microphones times number of speaker positions. The number of retransmissions (column “Ret.”) indicates how many times the speech data (LibriSpeech Test-clean, 2000 HUB5 English evaluation set, and NIST SRE 2010) was retransmitted. While RIR data was recorded for each speaker position, the audio was not retransmitted for all of them, as it is a very time consuming process.

	Size	Volume	# RIRs	Ret.	Type
<i>Q301</i>	10.7x6.9x2.6	192	31 × 3	1	Office
<i>L207</i>	4.6x6.9x3.1	98	31 × 6	2	Office
<i>L212</i>	7.5x4.6x3.1	107	31 × 5	2	Office
<i>R112</i>	4.4x2.8x2.6*	40	31 × 5	0	Hotel room
<i>L227</i>	6.2x2.6x14.2	229	31 × 11	3	Stairs
CR2	28.2x11.1x3.3	1033	31 × 4	0	Conf. room
E112	11.5x20.1x4.8*	900	31 × 2	0	Lect. room
D105	17.2x22.8x6.9*	2000	31 × 5	1	Lect. room

TABLE I

LIST OF ROOMS IN THE CURRENT DISTRIBUTION OF BUT REVERBDB . THE STAR DENOTES ROOMS WITH NON-BLOCK SHAPE (FOR EXAMPLE AN “L” SHAPE). THE VOLUME IS AN APPROXIMATION. THE NUMBER OF RIRs CONSISTS OF THE NUMBER OF MICROPHONES TIMES NUMBER OF SPEAKER POSITIONS. COLUMN “RET.” INDICATES NUMBER OF SPEECH DATA RETRANSMISSIONS. THE *CURSIVE* FONT DENOTES 2 ROOMS USED IN CZECH EXPERIMENT (SECTION V), THE **BOLD** FONT DENOTES 4 ROOM USED IN AMI EXPERIMENT (SECTION VI).

We plan to continue in the collection of BUT ReverbDB. Our goal is about 50 in-door environments including cars. We also plan to increase the number of devices by using a 2nd order ambisonic microphone, tablets, mobile phones and headsets. Any ideas are welcome.

V. ASR EXPERIMENTS - CZECH

We did this set of experiments to prove, that the RIR estimation is correct and to compare different approaches for RIR estimation.

We used a pre-trained ASR based on stacked-bottleneck architecture [38]. The 8kHz training data consists of 3900hrs of telephone speech, close talk data, distant microphone data and augmented data (RIRs artificially generated by ISM and a set of publicly available noises¹⁵). See table II for details. The vocabulary and language model were derived from acoustic data transcriptions. We consider this recognizer as robust enough to provide us meaningful results. We did not adapt neither acoustic model nor language model of the ASR on the test data (no speaker adaptation, no NN fine-tuning, etc.).

We conducted experiments to:

¹⁵<http://freesound.org>

data	amount	in test-set	type
SpeeCon [37]	759.4h (+996.2h)	69.9m / 15	prompted, close talk, distant mic.
Third party	641.7h (+1128.8h)	22.9m / 14	prompted, spontaneous, close talk, distant mic.
Ministry of Def.	140.0h (+247.3h)	none	Spontaneous, telephone
SUM	3913.4h	92m / 39	-

TABLE II

DATA SOURCES USED FOR CZECH ASR TRAINING. AUGMENTED DATA AMOUNTS ARE IN BRACKETS. WE USED MIX OF REVERBERATION USING RIRs GENERATED BY ISM AND ADDITIVE NOISES. "IN TEST-SET" DENOTES DURATION (IN MINUTES) AND NUMBER OF SPEAKERS USED FOR ASR EXPERIMENTS IN THIS PAPER.

- investigate the influence of background noise on data augmentation.
- compare MLS and ESS methods for RIR estimation.
- compare real retransmission with artificial retransmission of speech test data.

We selected a reasonable test-set to conduct experiments and to be retransmitted in various environments. We used only clean close-talk data without reverberation and noise in background as source for retransmission: 92 minutes of prompted speech and phonetically balanced sentences from 39 speakers (gender and age balanced) – see table II. We achieved 75.9% of word accuracy on the clean test-set; this is our **baseline**. We used the reference speech/non-speech segmentation in decoding the retransmitted data in further experiments, in order to suppress the influence of Voice Activity Detection (VAD) on overall results and conclusions.

We denote **Retransmit** (real retransmission) the test-set which was replayed in the particular room and hence recorded with the room natural reverberation and background noise. We denote **ESS / ISM** (artificial retransmission) the test-set, where the clean data was convolved with the RIRs either estimated by ESS or generated by ISM method. If the noise was added, we mark it by **noise** label. We add the real recorded noise from the particular room and microphone using the same Signal-to-Noise Ratio (SNR) as was estimated from the real retransmission condition. In generating RIRs using ISM, we did our best to be as close as possible to the real room setup (room dimensions, speaker and microphone position, microphone orientation, RT60 value).

A. Compensation of clock asynchronicity

We conducted an experiment, where we compensated the difference in clocks for the playback and recording device. We applied the cross-correlation function on the first and last recorded period of the MLS signal (we use 32 repetitions of the MLS sequence of order 18). The cross-correlation estimates the time shift (see figure 6). The time shift was then applied in re-sampling of the recorded MLS sequence to match the played one sample-to-sample. See figure 7 for RIR with and without the sampling frequency compensation.

Finally, we did an experiment where RIRs of two rooms were estimated for 31 microphones. The test data was then

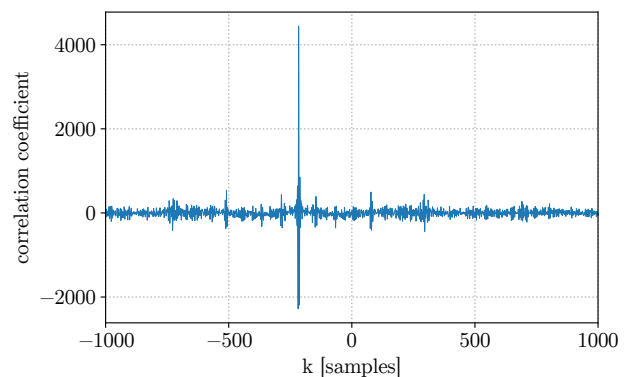

Fig. 6. Cross-correlation of the first and the last (32^{nd}) period of recorded MLS sequence. The time shift indicates the mismatch of playback and recording devices clocks; in this example, the playback device is 0.0027% faster than the recording one.

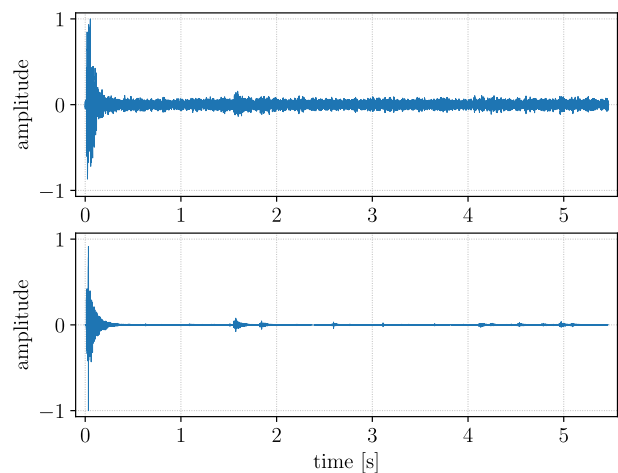

Fig. 7. Top panel shows a RIR estimated by MLS without playback and recording device clock synchronization. Notice the noise in the late reflections. Bottom panel shows RIR when the recorded MLS sequence was re-sampled to match the playback sampling frequency.

artificially reverberated and processed by the ASR, and we compared word accuracies of MLS- and ESS-processed test data. The average difference between compensated MLS and ESS is only 0.37% absolute on word error rate.

Our conclusion is, that MLS can be used in our setup to estimate the RIR, but one has to compensate for the clock mismatch. We decided not to use MLS in further experiments and stick to ESS, but we continue in recording both MLS and ESS signals and let the user choose.

B. Synthetic (ISM) vs. real (ESS) RIRs

This section compares the influence of synthetic RIR (ISM estimation) and real RIR (ESS estimation) on the word accuracy. We used RIRs from two rooms and compared the Artificial-Retransmitted data to the Real-Retransmitted. As we can see from figures 8 and 9, there is a gap between the Real-Retransmitted and both Artificial-Retransmitted data. This is caused by missing noise (see the following section). The ESS method provides slightly more realistic RIRs to the ISM, as the word accuracies are closer to the Real-Retransmitted data.

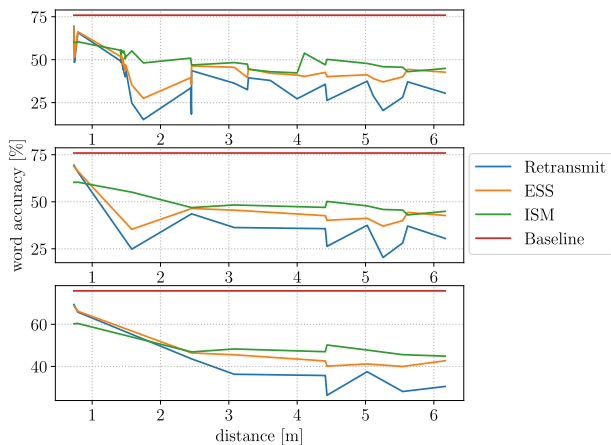

Fig. 8. Comparison of Real-Retransmitted, ESS Artificial-Retransmitted and ISM Artificial-Retransmitted test-sets in room L207. We sorted the microphones according to the distance from the speaker (x-axis). Top panel shows all microphones. Middle panel shows only microphones in front of the speaker ($\pm 90^\circ$). Bottom panel shows only microphones in front of the speaker ($\pm 90^\circ$) with direct visibility.

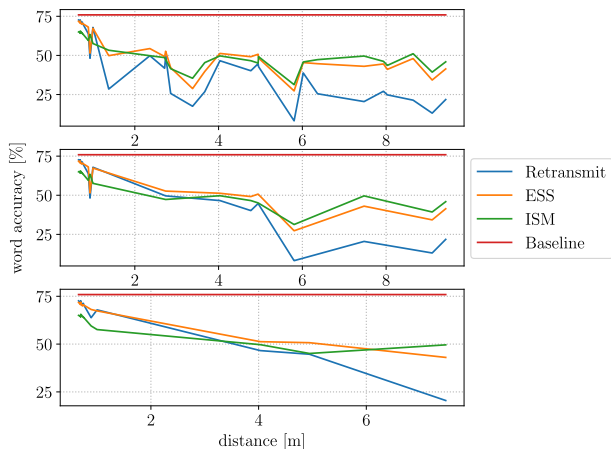

Fig. 9. Comparison of Real-Retransmitted, ESS Artificial-Retransmitted and ISM Artificial-Retransmitted test-sets in room Q301. We sorted the microphones according to the distance from the speaker (x-axis). Top panel shows all microphones. Middle panel shows only microphones in front of the speaker ($\pm 90^\circ$). Bottom panel shows only microphones in front of the speaker ($\pm 90^\circ$) with direct visibility.

C. Influence of noise on room acoustic simulation

We show the need of noise for test data processing in this section. We use the same data setup as in the previous section and add noise. It is a matching noise, as it comes from the particular room and microphone as mentioned earlier. As we can see from figures 10 and 11 compared to figures 8 and 9, the gap between the Real-Retransmitted and ESS Artificial-Retransmitted data almost disappears. On the other hand, there is still a gap between ISM and ESS methods showing, that the artificial RIR estimation is not good enough especially for microphones placed in non-common positions (drawer, waste bin, book shelf, etc.).

We consider the Czech ASR results as a proof of our recording and RIR estimation setup.

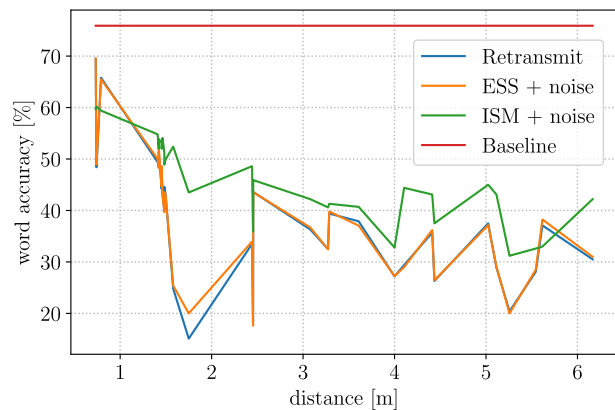

Fig. 10. Comparison of Real-Retransmitted, ESS Artificial-Retransmitted and ISM Artificial-Retransmitted test-sets in room L207. We sorted the microphones according to the distance from the speaker (x-axis).

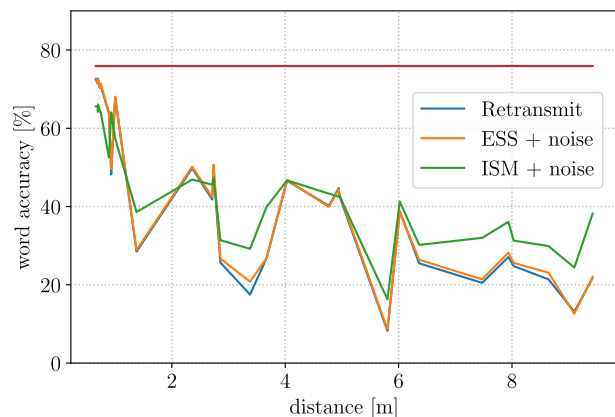

Fig. 11. Comparison of Real-Retransmitted, ESS Artificial-Retransmitted and ISM Artificial-Retransmitted test-sets in room Q301. We sorted the microphones according to the distance from the speaker (x-axis).

VI. AUTOMATIC SPEECH RECOGNITION EXPERIMENTS - AMI

In a real-world ASR, one has to train ASR able to cope with a particular channel (far-field microphone in our case) without having target training data. We used AMI dataset [39] to run this experiment. Our unseen channel was the *Single Distant Microphone – SDM* and the only data available was *Independent Headset Microphone – IHM*. Our goal is to test data augmentation of AMI data using BUT ReverbDB and to investigate into suitable reverberation techniques. We do not run extensive experimentation with noises; we use just the noises from BUT ReverbDB and add them to the training audio.

This set of experiments is inspired by Ko et al. [12]. Their work was aimed at comparison of real and simulated RIRs and adding point source noises to ASPIRE [5] and AMI datasets. On AMI, they however reported only the impact of adding reverberated close-talk data (IHM) to the genuine distant microphone training data (SDM/MDM). We are not using SDM/MDM at all in the training.

We selected four BUT ReverbDB rooms closest to AMI meeting rooms in type and dimensions as a source of real RIRs: Q301, L207, L212, and R112 – see table I. As the

goal of this paper is not to achieve the best results on AMI but to present and validate the BUT ReverbDB, we did not use other public RIR sources. We generated artificial RIRs similar to the four real rooms to compare artificial versus real RIRs. Theoretically, we can generate large number of artificial RIRs with a good chance to hit the same room configuration (dimensions, reflection coefficients, speech source and microphone position) as the target data (AMI dataset). We consider it as cheating for the time being, but we would like to perform such a experiment in our future work.

Each experiment is tagged with used RIR set: artificial RIR (**AR**) or real RIR (**RR**) is accompanied with number of RIRs used (**2k**, **306**, **30**). We add tag **ctXm** noting the microphone is in range of 1 to X meters from the speaker. **vis** denotes direct visibility between the microphone and the speaker. Finally, **f2f** denotes “face-to-face” orientation of microphone and speaker. In this way, **30.vis.ct2m.f2f* denotes a set of 30 RIRs, where microphones are directly visible, closer than 2 meters and face-to-face oriented to the speaker, **306.vis.ct3m* denotes a set of 306 RIRs, where microphones are directly visible and closer than 3 meters to the speaker.

The training data augmentation was done in two steps: 1) reverberating the IHM audio files using selected RIRs, and 2) adding stationary noises to achieve SNR in range 10 to 20dB with uniform distribution. The reverberation was done in two ways: either we convolved one whole audio file with one RIR, or changed the RIRs on-the-fly during convolution (see section VI-D for details).

A. Baseline system description

For acoustic models training, we used standard AMI recipe in Kaldi [40]. The baseline system is depicted in figure 12 above the dashed line. First, 13-dimensional MFCC, delta and double-delta features are extracted. Cepstral mean and variance normalization (CMVN) is performed. Mono-phone GMM-HMM model is trained on a subset of the training data (about 10.8 hours of AMI IHM audio). All the data is then aligned using this system. Context-dependent tri-phone model training on the full training set (about 78 hours of audio) follows, and the data is re-aligned. Further, features are spliced together, projected to 40-dimensional space using linear discriminant analysis (LDA) and a de-correlation based on maximum likelihood linear transform (MLLT) is applied. In the last step, the model is retrained using speaker adaptive training (SAT). The training data is re-segmented and only the audio matching the transcriptions is selected (cleaning process) based on decoding with the GMM-HMM model and biased language model built from reference transcript. In this way, about 7 hours of audio are discarded from the full training set. After this, the cleaned full training set is speed perturbed (original plus two speed alternations) resulting in about 210 hours of training audio. The state alignments generated by GMM-HMM system are used for DNN training. The DNNs are trained on 40-dimensional filter-bank energies along with 100-dimensional i-Vectors [41]. A time delayed neural network (TDNN) trained with lattice-free MMI objective is used as the final acoustic model.

B. Modifications of Kaldi baseline

The standard AMI recipe uses the training data both for cleaning and segmentation, and for the actual acoustic model training. When using reverberated data for all these steps, we found significant decrease of accuracy (caused obviously by worse models) and fluctuations in the amount of retained audio. Therefore, we decided to “freeze” the baseline system segmentation across all further experiments which also implies that the same amount of training data was used (210 hours with speech perturbation). The segmentation also served for i-Vector resets (see below in section VI-D). In the same manner, we also consistently used the baseline system alignment to train all DNN acoustic models. The modifications of baseline system for the reverberated data are depicted in figure 12 below the dashed line.

C. Averaging results

When we experimented with Kaldi AMI recipe, we found that the resulting WER is not stable enough. When an experiment was run several times, we observed WER fluctuations in tenths of percent. The stability does not improve when adding more NN training iterations. As some of our experiments differ also in tenths of percents, our conclusions would not be statistically significant. That is why all results presented in this section are averages over 5 runs of ASR training, see figure 13 for details. We performed Student’s T-test on selected pairs of systems with close average results. We concluded, that 0.2% absolute difference on WER for the significance level $\alpha = 0.05$ is statistically significant (0.1% absolute difference is not significant).

D. Per segment reverberation

The problems of AMI dataset are long recording and relatively small number of speakers (547). So even if we generate thousands of RIRs using ISM, only 547 are used if we apply one RIR on one whole audio file. The AMI recipe contains speaker adaptation using i-Vectors [41]. Each i-Vector is estimated on-the-fly on 2–10 speech segments and then it is reset to ensure data variability and to prevent neural net over-training. We modified our reverberation algorithm to allow changes of RIR during convolution with the audio. In the end, every speaker is reverberated with a set of RIRs and the data variety is increased compared to single audio file reverberation.

The results (table III) show, that bringing more environmental variability per i-Vector reverberation decreases WER from 43.42%/48.46% to 41.80%/47.06% for SDM dev / eval set. We also conducted an experiment, where we changed the RIR only in silences longer than 3 seconds, to overcome transitions in convolution, as the RIR is 1 second long. This also somewhat stabilizes the channel for the i-Vector extraction and makes the i-Vectors focus on the speaker rather than acoustic environment. Here, we got another slight WER decrease from 41.80%/47.06% to 41.70%/46.74% on SDM dev / eval.

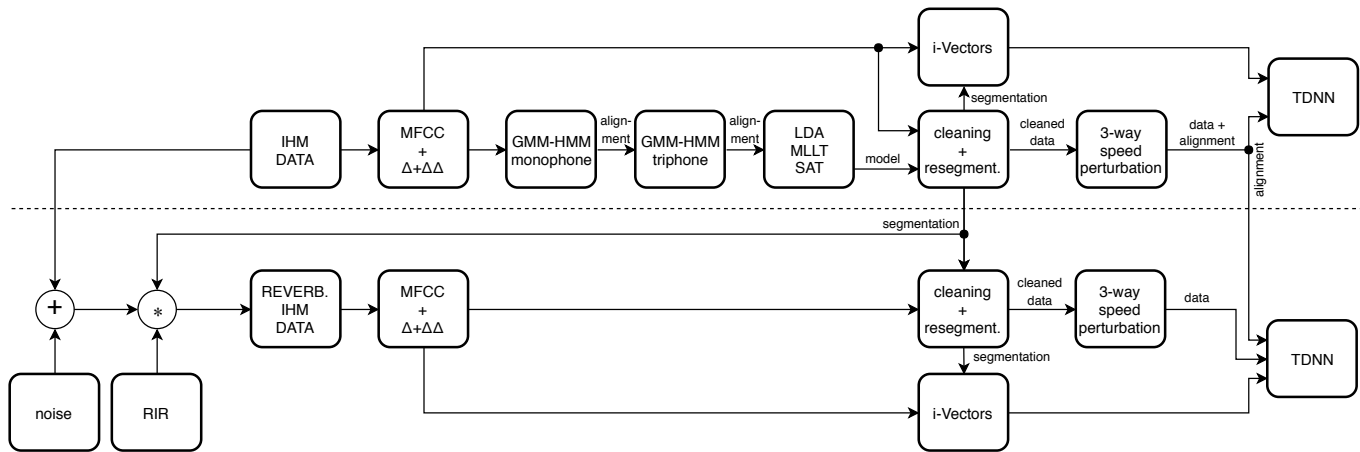

Fig. 12. Schemes of the baseline system (above the dashed line) and the modified system for reverberated data (below the dashed line).

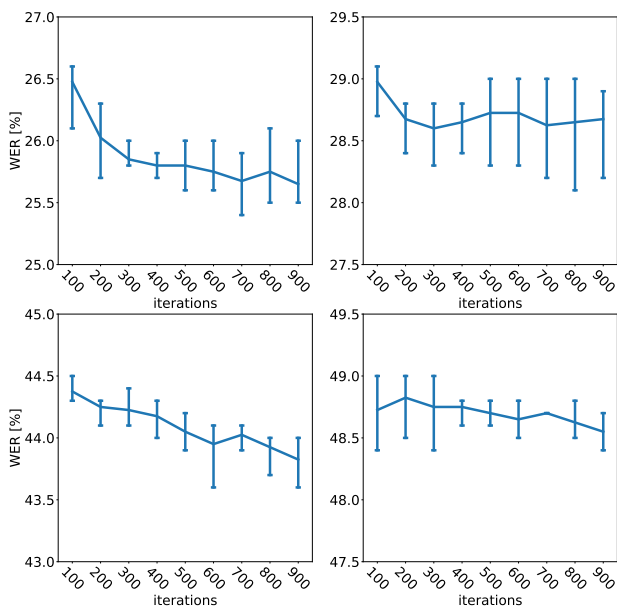

Fig. 13. Comparison of mean WER (over 5 runs). X-axis is the number of iterations in training NN, Y-axis is achieved WER for IHM (top row), SDM (bottom row), dev (left column), and eval (right column) sets. The solid left-to-right line connects means, the top and bottom lines show maximum and minimum WERs achieved for particular run.

System	Segm #	WER			
		IHM		SDM	
		dev	eval	dev	eval
ihm.AR2k.ct3m.insil	36357	21.52	23.06	41.70	46.74
ihm.AR2k.ct3m.per1seg	33312	21.44	23.02	41.80	47.06
ihm.AR547.ct3m.perfile	547	21.72	23.24	43.42	48.46

TABLE III

COMPARISON OF “PER SEGMENT” WITH “PER FILE” REVERBERATION. *per1seg* SETUP CHANGES RIR IN SYNCHRONY WITH KALDI I-VECTOR SPEAKER ADAPTATION. *insil* DENOTES EXPERIMENT, WHERE RIR IS CHANGED ONLY IN SILENCES LONGER THAN 3 SECONDS. COLUMN *Segm #* SHOWS NUMBERS OF SEGMENTS WITH FIXED RIR. WE RANDOMLY DRAW 547 RIRS FROM 2000 SET FOR IHM.AR547.CT3M.PERFILE SYSTEM.

E. Room impulse response passivation and delay compensation

Having estimated real or generated artificial RIRs, one may post-process them to achieve more consistent results

and to overcome over-excitation and delays caused by the convolution. The delay in any RIR is caused by speed of sound and can be partly compensated by measurement of microphone to speaker distance. However, precise compensation is hard due to humidity and air pressure changes. Delay compensation in ISM synthesis of RIR is theoretically straightforward; the delay can be computed analytically. On the other hand, it may produce an incorrectly delayed RIR in a case of 1) selecting a cardioid microphone and 2) placing the sound source exactly behind the microphone. In this case, the direct signal is zero and we see only the reflections with larger delay than we expect from microphone–speaker distance and speed of sound. We denote systems with applied delay compensation by tag **shi**.

System	WER			
	IHM		SDM	
	dev	eval	dev	eval
ihm.AR2k.vis.ct3m.perfile	25.80	28.40	44.38	48.48
ihm.AR2k.pas.vis.ct3m.perfile	21.72	23.24	43.42	48.46
ihm.RR306.vis.ct3m.perfile	25.83	28.35	44.05	48.55
ihm.RR306.pas.vis.ct3m.perfile	25.44	28.42	44.14	48.54
ihm.AR306.pas.vis.ct3m.per1seg	21.40	23.00	41.72	46.76
ihm.AR306.pas.shi.vis.ct3m.per1seg	21.46	23.35	41.78	47.30
ihm.RR306.pas.vis.ct3m.per1seg	25.22	27.18	43.26	47.42
ihm.RR306.pas.shi.vis.ct3m.per1seg	25.32	27.72	43.10	47.12
ihm.RR30.pas.vis.ct2m.f2f.per1seg	23.12	24.80	42.30	46.36
ihm.RR30.pas.shi.vis.ct2m.f2f.per1seg	22.88	24.42	42.42	46.44

TABLE IV

COMPARISON OF THE EFFECT OF PASSIVATION PAS – TOP PANEL, AND DELAY SHIFT SHI – BOTTOM PANEL, ON VARIOUS RIR SETS.

Another problem is over-excitation caused by amplifying the audio using a RIR, leading to signal clipping. To overcome this, we scale the RIR to a level which ensures that no single magnitude in frequency response is larger than 1. We denote systems with applied passivation by tag **pas**.

We summarized results with RIR passivation and delay shift in table IV. Passivation experiments are shown in the first four lines, both for artificial and real RIRs. We can clearly conclude, that passivation significantly helps for artificial RIRs in IHM condition. Passivation does not bring any significant improvement for real RIRs. This leads to conclusion that ReverbDB RIRs are well estimated and will not cause over-

excitation compared to ISM generated RIRs which may cause signal clipping.

The last four lines aim at RIR delay compensation. When analyzing the distribution of delays, we found, that artificial RIRs have a peak at 0 seconds with about 1/4 of them uniformly distributed from 0 to 0.02 seconds (2 frames). On the other hand, real RIRs delay distribution is “Gaussian” with peak at 0 and tailing to ± 0.05 seconds with extreme values reaching 0.14 second (14 frames). A negative delay can be caused for example by less precise speaker to microphone distance measurement.

A small positive delay is not so substantial as it only leads to delaying the reverberated audio with respect to the alignment, and delay within 1 – 2 frames can be considered as wanted variability. Larger delays may cause degradation due to desynchronization of the audio and alignment in NN training (see section VI-B). However, a negative delay is critical, as when we try to compensate it, the beginning of RIR (containing the first or early reflections!) is cut off. Such trimmed RIR is damaged, as it does not carry full information on the acoustic environment anymore.

The results (lines 5 and 6 in table IV) show, that applying delay compensation (synchronizing all RIRs to start at 0 seconds) for artificial RIRs does not have significant impact except for small deterioration for SDM eval set. Applying delay compensation for real RIRs (lines 7 to 10 in table IV) has mixed results. Small errors in distance measurement can actually bring wanted variability to the augmented data in some cases.

We decided to use passivation but not delay compensation in further experiments, as the former has clear gain, but the results of the later can be considered as statistical noise.

F. Synthetic versus real room impulse responses on AMI data

System	WER			
	IHM		SDM	
	dev	eval	dev	eval
ihm (baseline)	20.02	20.04	60.12	72.70
ihm.AR2k.pas.vis.ct3m.per1seg	21.44	23.02	41.80	47.06
ihm.RR306.pas.vis.ct3m.per1seg	25.22	27.18	43.26	47.42
ihm.AR306.pas.vis.ct3m.per1seg	21.40	23.00	41.72	46.76
ihm.RR30.pas.vis.ct2m.f2f.per1seg	23.12	24.80	42.30	46.36
ihm.AR30.pas.vis.ct2m.f2f.per1seg	21.86	23.70	41.92	46.76
ihm.RR306.pas.vis.ct3m.per1seg + ihm.AR306.pas.vis.ct3m.per1seg	22.30	23.90	41.80	46.24
ihm.RR30.pas.vis.ct2m.f2f.per1seg + ihm.AR2k.pas.vis.ct3m.per1seg	21.86	23.22	41.54	46.12
sdm1 (target)	29.38	36.74	35.72	39.65

TABLE V

COMPARISON OF VARIOUS ASRS TRAINED ON AUGMENTED IHM TO THE BASELINE (ASR TRAIN ON CLEAN IHM) AND “CHEATING” TARGET (ASR TRAINED ON SDM) SYSTEMS. THE BOTTOM PART COMPARES SYSTEM COMBINATION (ON TRAINING DATA LEVEL).

We compared the influence of artificial RIRs (ISM generated) with real RIRs (estimated from BUT ReverbDB using ESS method) in the following experiments. Remember, that the scenario is training ASR to target an unseen environment (AMI meeting rooms) without having any target data. We tried to answer the following questions:

- How many RIRs are sufficient?
- Are artificial RIRs superior to real ones?
- Are artificial and real RIRs complementary?

We summarized our results in table V. The baseline system **ihm** is trained on AMI IHM data using default Kaldi recipe (Section VI-A). This system performs well on in-domain IHM dev (20.02% WER) and eval (20.04% WER) data, but very badly on target (out-of-domain) SDM dev (60.12% WER) and eval (72.70% WER). To have an idea of the best reachable WER, we trained the system on target data – **sdm1**, in the same way as the **ihm**. We achieved expected huge improvement on (in this case in-domain) SDM dev (35.7%) and eval (39.6%) data, but significant deterioration on (now out-of-domain) IHM dev (29.3%) and eval (36.7%) data.

We then applied various data augmentation techniques on IHM training data to simulate the target environment and to achieve an ASR adapted to SDM data, without seeing any SDM data. We use the following notation:

- RR30 – set of 30 real RIRs including 30 microphones from 4 rooms of BUT Reverb DB (see section IV-E) with microphones in range of 1 – 2 meters from the speaker and face-to-face orientation.
- RR306 – set of 306 real RIRs including 306 microphones from the 4 rooms with microphones in range of 1 – 3 meters from the speaker and direct visibility. *RR306* is superset of *RR30*.
- AR30 – set of 30 artificially generated RIRs with microphones in range of 1 – 2 meters from the speaker and face-to-face orientation. This set is a random draw from larger set of artificial RIRs with parameters set to as close as possible to the 4 rooms. This set should be comparable to *RR30*.
- AR306 – set of 306 artificially generated RIRs with microphones in range of 1 – 3 meters from the speaker and direct visibility. This set is a random draw from *AR2k* set
- AR2k – set of 2000 artificially generated RIRs with microphones in range of 1 – 3 meters from the speaker and direct visibility. Parameters of the RIRs are as close as possible to the 4 rooms.

Comparing results of five systems from upper part of table V we conclude, that using larger set of RIRs is not always beneficial — see significant gain when going from *AR30* to *AR306*, but no gain or even deterioration when going from *AR306* to *AR2k* and significant deterioration for real RIRs – going from *RR30* to *RR306*. We conclude that a careful selection of RIRs covering target scenario is important.

Comparing the artificial RIR (*AR**) to real RIR (*RR**) systems shows no clear winner. Artificial RIRs have significant advantage in working well also on IHM data making the ASR more robust on both IHM and SDM data. On the other hand *ihm.RR30.pas.vis.ct2m.f2f.per1seg* system is significantly better on SDM eval set.

Finally, artificial and real RIRs seem to be complementary and their combination is beneficial (see bottom part of table V). The combination was done on the level of training data by taking one half of data augmented by artificial RIRs

and one half of data augmented by real RIRs (in order to train always on the same amount of data). *RR30 + AR2k* achieved the best WER on SDM data set with small deterioration on IHM data set compared to the best single systems.

VII. CONCLUSIONS AND FUTURE WORK

This paper presents BUT ReverbDB, a public set of RIRs, noise and retransmitted data for ASR and SRE development and testing. The set is available for free under non-restrictive license, and is covering non-standard positions of microphones interesting for investigation/intelligence scenarios. Currently, the set contains data from 8 rooms and will continue to grow. We believe that our paper can serve as a cook-book of how to collect such dataset.

A set of Czech ASR experiments aiming at test data preparation was performed in order to check and validate the database, with interesting findings: Clock asynchronicity problem in RIR estimation by MLS technique was studied and we found that it can be fixed by estimation the clock ratio using cross-correlation (when applied, we obtained comparable WER results as with ESS technique). We also confirmed other papers' conclusion on the importance of adding real noise in ASR test data preparation. Finally, we observed clear superiority of real RIRs over artificial ones.

AMI experiments targeted training of an ASR system on data augmented by real or artificial RIRs. We have found the passivation of RIR extremely important, and recommend to check this issue in other RIR datasets. We also concluded that knowing the target room configuration is beneficial, as we obtained better results with a few carefully selected RIRs than with a huge number of randomly picked ones. In real applications, this calls for a system capable of extracting RIRs from reverberated audio and its use for augmentation of training data. We have also shown that real and artificial RIRs are complementary, and investigated into a number of technical (but nonetheless important) issues such as reverberation of long audio files per speaker, and RIR delay compensation.

In future work, we would like to grow our data-set, and extend it with real speech data. Our experimental work will include investigation into the influence of having just one or two IRs from one room rather than many IRs from one room, simplification of ASR system (i.e. producing results without i-Vector adaptation) and changing also the noise within each speaker adaptation segment.

REFERENCES

- [1] M. Karafiát, K. Veselý, K. Žmolíková, M. Delcroix, S. Watanabe, L. Burget, J. Černocký, and I. Szóke, *Training Data Augmentation and Data Selection*, ser. Computer Science, Artificial Intelligence. Springer International Publishing, 2017, pp. 245–260.
- [2] V. Panayotov, G. Chen, D. Povey, and S. Khudanpur, “LibriSpeech: An ASR Corpus based on Public Domain Audio Books,” in *2015 IEEE International Conference on Acoustics, Speech and Signal Processing (ICASSP)*, April 2015, pp. 5206–5210.
- [3] V. Greenberg, A. Martin, D. Graff, L. Brandschain, and K. Walker, “2010 NIST Speaker Recognition Evaluation Test Set LDC2017S06,” Tech. Rep., 2017.
- [4] T. Yoshioka, A. Sehr, M. Delcroix, K. Kinoshita, R. Maas, T. Nakatani, and W. Kellermann, “Making Machines Understand Us in Reverberant Rooms: Robustness Against Reverberation for Automatic Speech Recognition,” *IEEE Signal Processing Magazine*, vol. 29, no. 6, pp. 114–126, Nov 2012.
- [5] M. Harper, “The Automatic Speech recognition In Reverberant Environments (ASpIRE) challenge,” in *2015 IEEE Workshop on Automatic Speech Recognition and Understanding (ASRU)*, Dec 2015, pp. 547–554.
- [6] A. Janin, D. Baron, J. Edwards, D. Ellis, D. Gelbart, N. Morgan, B. Peskin, T. Pfau, E. Shriberg, A. Stolcke, and C. Wooters, “The ICSI Meeting Corpus,” in *2003 IEEE International Conference on Acoustics, Speech, and Signal Processing, 2003. Proceedings. (ICASSP '03)*, vol. 1, April 2003, pp. I–I.
- [7] S. H. K. Parthasarathi, S. Chang, J. Cohen, N. Morgan, and S. Wegmann, “The Blame Game in Meeting Room ASR: An analysis of Feature Versus Model Errors in Noisy and Mismatched Conditions,” in *2013 IEEE International Conference on Acoustics, Speech and Signal Processing*, May 2013, pp. 6758–6762.
- [8] T. Hain, L. Burget, J. Dines, G. Garau, V. Wan, M. Karafiat, J. Vepa, and M. Lincoln, “The AMI System for the Transcription of Speech in Meetings,” in *2007 IEEE International Conference on Acoustics, Speech and Signal Processing - ICASSP '07*, vol. 4, April 2007, pp. IV–357–IV–360.
- [9] M. Lincoln, I. McCowan, J. Vepa, and H. K. Maganti, “The Multi-channel Wall Street Journal Audio Visual Corpus (MC-WSJ-AV): Specification and Initial Experiments,” in *IEEE Workshop on Automatic Speech Recognition and Understanding, 2005.*, Nov 2005, pp. 357–362.
- [10] L. Brandschain, D. Graff, C. Cieri, K. Walker, C. Caruso, and A. Neely, “Mixer 6,” in *Proceedings of the Seventh International Conference on Language Resources and Evaluation (LREC'10)*, N. C. C. Chair, K. Choukri, B. Maegaard, J. Mariani, J. Odijk, S. Piperidis, M. Rosner, and D. Tapias, Eds. Valletta, Malta: European Language Resources Association (ELRA), may 2010.
- [11] J. Melot, N. Malyska, J. Ray, and W. Shen, “Analysis of Factors Affecting System Performance in the ASpIRE Challenge,” in *2015 IEEE Workshop on Automatic Speech Recognition and Understanding (ASRU)*, Dec 2015, pp. 512–517.
- [12] T. Ko, V. Peddinti, D. Povey, M. L. Seltzer, and S. Khudanpur, “A study on Data Augmentation of Reverberant Speech for Robust Speech Recognition,” in *2017 IEEE International Conference on Acoustics, Speech and Signal Processing (ICASSP)*, March 2017, pp. 5220–5224.
- [13] J. Barker, E. Vincent, N. Ma, H. Christensen, and P. Green, “The PASCAL “CHiME” Speech Separation and Recognition Challenge,” *Computer Speech & Language*, vol. 27, pp. 621–633, 05 2013.
- [14] E. Vincent, J. Barker, S. Watanabe, J. L. Roux, F. Nesta, and M. Matasoni, “The second CHiME Speech Separation and Recognition Challenge: An overview of Challenge Systems and Outcomes,” in *2013 IEEE Workshop on Automatic Speech Recognition and Understanding*, Dec 2013, pp. 162–167.
- [15] J. Barker, R. Marxer, E. Vincent, and S. Watanabe, “The third “CHiME” Speech Separation and Recognition Challenge: Dataset, Task and Baselines,” in *2015 IEEE Workshop on Automatic Speech Recognition and Understanding (ASRU)*, Dec 2015, pp. 504–511.
- [16] J. Barker, S. Watanabe, E. Vincent, and J. Trmal, “The fifth “CHiME” Speech Separation and Recognition Challenge: Dataset, Task and Baselines,” Tech. Rep., 2018. [Online]. Available: <https://arxiv.org/pdf/1803.10609.pdf>
- [17] K. Kinoshita, M. Delcroix, T. Yoshioka, T. Nakatani, A. Sehr, W. Kellermann, and R. Maas, “The REVERB Challenge: A Common Evaluation Framework for Dereverberation and Recognition of Reverberant Speech,” in *2013 IEEE Workshop on Applications of Signal Processing to Audio and Acoustics*, Oct 2013, pp. 1–4.
- [18] K. Kinoshita, M. Delcroix, S. Gannot, E. A. P. Habets, R. Haeb-Umbach, W. Kellermann, V. Leutnant, R. Maas, T. Nakatani, B. Raj, A. Sehr, and T. Yoshioka, “A Summary of the REVERB Challenge: State-of-the-art and Remaining Challenges in Reverberant Speech Processing Research,” *EURASIP Journal on Advances in Signal Processing*, vol. 2016, no. 1, p. 7, Jan 2016.
- [19] M. Ravanelli, P. Svaizer, and M. Omologo, “Realistic Multi-microphone Data Simulation for Distant Speech Recognition,” November 2017. [Online]. Available: [arXiv:1711.09470v1](https://arxiv.org/abs/1711.09470v1)
- [20] M. Jeub, M. Schafer, and P. Vary, “A Binaural Room Impulse Response Database for the Evaluation of Dereverberation Algorithms,” in *2009 16th International Conference on Digital Signal Processing*, July 2009, pp. 1–5.
- [21] S. Nakamura, K. Hiyane, F. Asano, T. Nishiura, and T. Yamada, “Acoustical Sound Database in Real Environments for Sound Scene Understanding and Hands-free Speech Recognition,” in *LREC*, 2000.
- [22] M. Ravanelli, L. Cristoforetti, R. Gretter, M. Pellin, A. Sosi, and M. Omologo, “The DIRHA-ENGLISH Corpus and Related Tasks for Distant-speech Recognition in Domestic Environments,” in *2015 IEEE*

- Workshop on Automatic Speech Recognition and Understanding (ASRU)*, Dec 2015, pp. 275–282.
- [23] N. Bertin, E. Camberlein, E. Vincent, R. Lebarbenchon, S. Peillon, É. Lamande, S. Sivasankaran, F. Bimbot, I. Illina, A. Tom, S. Fleury, and É. Jamet, “A French Corpus for Distant-microphone Speech Processing in Real Homes,” in *Proceedings of the Annual Conference of the International Speech Communication Association, INTERSPEECH, San Francisco, United States*, 09 2016, pp. 2781–2785.
- [24] M. Vacher, B. Lecouteux, P. Chahuaara, F. Portet, B. Meillon, and N. Bonnefond, “The Sweet-Home Speech and Multimodal Corpus for Home Automation Interaction,” in *The 9th edition of the Language Resources and Evaluation Conference (LREC)*, Reykjavik, Iceland, 2014, pp. 4499–4506. [Online]. Available: <http://hal.archives-ouvertes.fr/hal-00953006>
- [25] J. Eaton, N. D. Gaubitch, A. H. Moore, and P. A. Naylor, “Acoustic Characterization of Environments (ACE) Challenge Results Technical Report,” Imperial College London, Tech. Rep., 2017. [Online]. Available: <https://arxiv.org/pdf/1606.03365.pdf>
- [26] —, “Estimation of Room Acoustic Parameters: The ACE Challenge,” *IEEE/ACM Trans. Audio, Speech and Lang. Proc.*, vol. 24, no. 10, pp. 1681–1693, Oct. 2016.
- [27] M. R. Schroeder, “Integrated-impulse Method for Measuring Sound Decay without using Impulses,” *The Journal of the Acoustical Society of America*, vol. 66, pp. 497–500, 1979.
- [28] C. Dunn and M. J. Hawksford, “Distortion Immunity of MLS-Derived Impulse Response Measurements,” *JOURNAL OF THE AUDIO ENGINEERING SOCIETY*, vol. 41, no. 5, pp. 314–335, 1993.
- [29] N. Aoshima, “Computer-generated Pulse Signal applied for Sound Measurement,” *The Journal of the Acoustical Society of America*, vol. 69, no. 5, pp. 1484–1488, 1981.
- [30] A. Farina, “Simultaneous Measurement of Impulse Response and Distortion with a Swept-sine Technique,” in *Audio Engineering Society Convention 108*, Feb 2000.
- [31] G. B. Stan, J. J. Embrechts, and D. Archambeau, “Comparison of different Impulse Response Measurement Techniques,” *JOURNAL OF THE AUDIO ENGINEERING SOCIETY*, vol. 50, pp. 249–262, 2002.
- [32] M. Ravanelli, A. Sosi, P. Svaizer, and M. Omologo, “Impulse Response Estimation for Robust Speech Recognition in a Reverberant Environment,” in *2012 Proceedings of the 20th European Signal Processing Conference (EUSIPCO)*, Aug 2012, pp. 1668–1672.
- [33] A. Farina, “Advancements in Impulse Response Measurements by Sine Sweeps,” in *Audio Engineering Society Convention 122*, May 2007.
- [34] M. R. P. Thomas, “MLS Project,” Tech. Rep., 2009. [Online]. Available: <http://www.commsp.ee.ic.ac.uk/~mrt102/projects/mls.html>
- [35] J. B. Allen and D. A. Berkley, “Image Method for Efficiently Simulating Smallroom Acoustics,” *The Journal of the Acoustical Society of America*, vol. 65, no. 4, pp. 943–950, 1979.
- [36] E. A. P. Habets, “Room Impulse Response Generator,” Tech. Rep., September 2010. [Online]. Available: <https://github.com/ehabets/RIR-Generator>
- [37] O. Glembek, M. Karafiát, L. Burget, and J. Černocký, “Czech Speech Recognizer for Multiple Environments,” in *Radioelektronika 2006*, 2006, pp. 1–4.
- [38] F. Grézl, M. Karafiát, and K. Veselý, “Adaptation of Multilingual Stacked Bottle-neck Neural Network Structure for New Language,” in *Proceedings of ICASSP 2014*. IEEE Signal Processing Society, 2014, pp. 7704–7708.
- [39] I. McCowan, J. Carletta, W. Kraaij, S. Ashby, S. Bourban, M. Flynn, M. Guillemot, T. Hain, J. Kadlec, V. Karaiskos, M. Kronenthal, G. Lathoud, M. Lincoln, A. Lisowska, W. Post, D. Reidsma, and P. Wellner, “The AMI Meeting Corpus,” L. Noldus, F. Grieco, L. Loijens, and P. Zimmerman, Eds. Noldus Information Technology, 8 2005, pp. 137–140.
- [40] D. Povey, A. Ghoshal, G. Boulianne, L. Burget, O. Glembek, N. Goel, M. Hannemann, P. Motlíček, Y. Qian, P. Schwarz, J. Silovský, G. Stemmer, and K. Veselý, “The Kaldi Speech Recognition Toolkit,” in *IEEE 2011 Workshop on Automatic Speech Recognition and Understanding*. IEEE Signal Processing Society, Dec. 2011.
- [41] V. Peddinti, G. Chen, D. Povey, and S. Khudanpur, “Reverberation Robust Acoustic Modeling using i-vectors with Time Delay Neural Networks,” in *INTER_SPEECH*. ISCA, 2015, pp. 2440–2444.