

Tree2Tree Neural Translation Model for Learning Source Code Changes

Saikat Chakraborty
University of Virginia
Virginia, USA
saikatc@virginia.edu

Miltiadis Allamanis
Microsoft Research
Cambridge, UK
miallama@microsoft.com

Baishakhi Ray
Columbia University
New York, USA
rayb@cs.columbia.edu

Abstract—The way developers edit day-to-day code tend to be repetitive and often use existing code elements. Many researchers tried to automate this tedious task of code changes by learning from specific change templates and applied to limited scope. The advancement of Neural Machine Translation (NMT) and the availability of the vast open source software evolutionary data open up a new possibility of automatically learning those templates from the wild. However, unlike natural languages, for which NMT techniques were originally designed, source code and the changes have certain properties. For instance, compared to natural language source code vocabulary can be virtually infinite. Further, any good change in code should not break its syntactic structure. Thus, deploying state-of-the-art NMT models without domain adaptation may poorly serve the purpose.

To this end, in this work, we propose a novel Tree2Tree Neural Machine Translation system to model source code changes and learn code change patterns from the wild. We realize our model with a change suggestion engine: CODIT. We train the model with more than 30k real-world changes and evaluate it with 6k patches. Our evaluation shows the effectiveness of CODIT in learning and suggesting abstract change templates. CODIT also shows promise in suggesting concrete patches and generating bug fixes.

I. INTRODUCTION

Developers often edit the source code to add new features, fix bugs, or maintain it (*e.g.*, API updates, refactoring, *etc.*). Recent research has shown that such edits are usually repetitive [1]–[3]. Moreover, the code components (*e.g.*, token, subtrees, *etc.*) used to build the edits are oftentimes taken from the existing codebase [4], [5]. However, manually applying such repetitive edits can be tedious and error-prone [6]. Thus, it is important to automate code changes, as much as possible, to reduce the developers’ burden.

There is a significant amount of work, both from academia and industry, on how to automate code changes. For example, modern IDEs provide support to automate specific types of source code changes (*e.g.*, refactoring, adding boilerplate code [7], [8], *etc.*). Many research tools aim to automate specific types of edits, *e.g.*, API related changes [9]–[14], refactoring [15]–[18], *etc.* Researchers also propose to automate generic changes by learning either from example edits [19], [20] or from similar patches applied previously to source code [2], [3], [21].

While the above lines of work are promising and have shown initial success, they either rely on predefined change templates or require domain-specific knowledge: both are hard

to generalize in the larger context. However, all of them leverage, in some way, common edit patterns. Given that a large amount of code and its change history are available thanks to software forges like GitHub, Bitbucket, *etc.*, a natural question arises: *Can we learn to predict general code changes in the wild?*

Recently there has been a lot of interest in using machine learning techniques to model and predict source code from real world [22]. However, modeling change is different from modeling code, as changes are conditioned upon previous code versions. Thus, in this work, we check whether machine learning models can capture the repetitiveness and statistical characteristics of code edits that regular developers apply daily. Such models can further automate code changes, bug fixes, and other software-evolution-related tasks.

To this end, we use a Neural Machine Translation (NMT) to learn from the previous code changes and suggest the future edits. In natural language processing, NMT is widely used to translate text from one language (*e.g.*, English) to another (*e.g.*, Spanish). For modeling code changes, NMT seem to be a natural fit as they can learn the translation (*i.e.* edits) from an original to the changed version of the code. Essentially these models learn the probability distribution of changes and assign higher probabilities to plausible code edits and lower probabilities to less plausible ones. In fact, Tufano *et al.* [23] shows the initial promise of using a sequence-to-sequence translation model (seq2seq) for fixing bugs in their new idea paper.

In this work, we design an encoder-decoder-based machine translation model that operates on the tree representation of the code to capture syntactic changes. Our key observation is that such tree-based models, unlike their token-based counterparts, can capture the rich structural properties of code and thus can produce syntactically correct patch. Using a Tree LSTM, the model first encodes the source tree to an intermediate representation. The decoder, which is a modified LSTM, learns from the intermediate representation and predicts the target tree. We use this model to realize a code change suggestion engine, CODIT, which takes an unmodified code fragment as input and suggests potential changes.

We evaluate CODIT using 44,382 patches from 54 open source GitHub projects collected from Travis Torrent dataset [24]. Our experiments show CODIT can achieve

26.53% accuracy in the top 20 suggestions while suggesting abstract patches; these patches are similar to change templates suggested by modern IDEs. CODIT can also suggest concrete patches with 6.33% accuracy in the top 20. These results are 96.96% and 42.25% higher than a Seq2Seq based model, which is the most common way to model natural language translation. We further evaluate CODIT’s performance in suggesting bug-fix patches of Defects4J dataset. CODIT can produce 8 complete fixes (*i.e.* 10%) and 2 partial fixes out of 80 bugs in the Defects4J dataset.

In summary, our key contributions are:

- We propose a novel code change modeling technique that leverages rich syntactic structure of the code to generate syntactically correct patches. To our knowledge, we are the first to model code changes with Tree2Tree translation model and propose some significant contribution from the modeling perspective.
- We realize our approach using a code change suggestion tool: CODIT. We prove the viability of using CODIT for suggesting patch templates, concrete changes, and bug fixes.
- We collected a large dataset of 44k real code changes. We plan to release our code and data for broader dissemination.

II. BACKGROUND

Modeling Code Change. Generating source code using machine learning models has been explored in the past [25]–[28]. Such models can be represented as a probability distribution $p(c|\kappa)$ where c is the code being generated and κ is the contextual information upon which the generated code is conditioned. In this work, as opposed to generating code, we want to generate *code edits*. Thus, we are interested in a model that can predict a piece of code given its previous version. This can be achieved using *Neural Machine Translation* (NMT), which is a special case of probability distribution $p(c|\kappa)$, where c is the new and κ is the previous version of the code. Thus, NMT allows to represent code edits using a single end-to-end model, taking into consideration the original version of a code and defining a conditional probability distribution of the target version. Such probability distribution can be written as $P(T|S)$, where S and T are the source and target of the edits. Similar concept has also been explored in NLP for paraphrasing [29].

Neural Machine Translation Model. NMT models are usually a cascade of an *Encoder* and a *Decoder*. The most common and successful NMT model is sequence-to-sequence (seq2seq) model [30], where the input is treated as a sequence of tokens and encoded by a sequential encoder (*e.g.*, LSTM). The output of the encoder is stored in an intermediate representation. Next, the decoder decodes the encoder output using another model, *e.g.*, LSTM, and produces a stream of tokens. In NMT literature, several improvements have been made over the base seq2seq model, such as *attention* [30] and *copying* [31]. Briefly, attention mechanism allows a model to automatically (soft-)search for parts of the source that are important in predicting a target. Copying is a special type of attention mechanism, where, the searched portion of the source

is directly copied to the target. We employed both attention and copying mechanisms in this work.

Tree-based modeling. While modeling source code using machine learning, the first thing we need to consider how to represent the code within the machine learning component. A large proportion of the literature resorts in representing source code as a token sequence [25], [26]. Such models, although successful in many tasks, fail to capture its rigid and rich syntactic structure. Syntactic machine learning models [32], [33] capture the parse or abstract syntax tree (AST) of the code. Although these models can take advantage of the syntactic structure but may still fail to capture some semantic information of the code, such as data dependencies. Finally, graph models [34], [35] of code can capture both syntactic and semantic properties. However, processing code directly as a graph is expensive, especially for the large codebases. In our work, we select to use a syntactic tree2tree model. Since we are interested in learning the edits from the wild, semantic information was not very relevant anyway. Thus, an expensive graph-based model would have been overkill.

III. MOTIVATING EXAMPLE

Figure 1 shows a motivating example to illustrate our approach. Here, the original code fragment $obj.val = v$ is changed to: $obj.val = checkNull(v)$. CODIT takes the two code fragments, as source and target respectively, to train an NMT model. While suggesting changes, CODIT takes an original code as input and outputs the modified version.

First, CODIT represents the code fragments as parse trees. Figure 1(a) shows the corresponding parse trees. Here, the change is applied to the source (S) tree node I and the corresponding subtree (rooted at node VAR) is replaced by a new sub-tree rooted at node `method_call` in target (T). The deleted and added subtrees are highlighted in **red** and **green** respectively. Note that, this is a common change pattern (addition of method call) in our training data. CODIT had automatically learned the pattern and applied it in the appropriate context. Additional information of the change context (marked in the non-highlighted nodes) further helps CODIT to generalize the learned patterns.

Figure 1(b) shows how we model the patch using a tree2tree NMT model: $p(T|S)$. Our model consists of two main parts: an encoder and a decoder. The TreeRNN-based encoder encodes the input source tree S to an intermediate representation, say s' . A decoder then decodes s' to target tree T .

Encoder. The encoder first encodes all the terminal nodes of S . For example, in Figure 1(b), the terminal node sequence (`obj`, `.`, `val`, `=`, `v`) is encoded first. Then, each non-terminal node is recursively encoded until the root node of the source tree is reached. In this way, root node H_6 presents the encoded form (s') of the whole source tree S .

Decoder. From the intermediate representation s' , the decoder generates the target tree (T). The tree generation starts with the `root` node. Then, at each subsequent step, the bottom-most, left-most node of the current tree is expanded. We call them

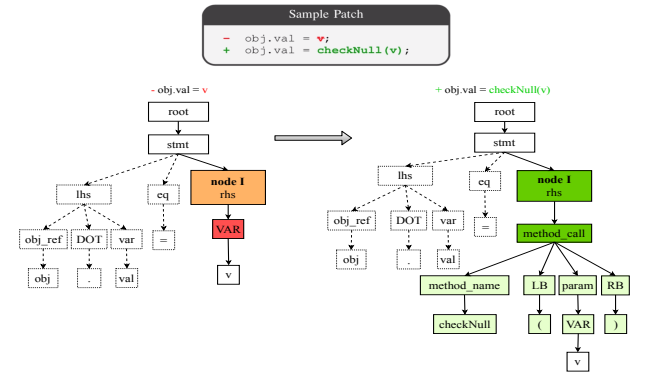

(a) Example of correctly suggested change by CODIT along with the source and target parse trees. The deleted and added nodes are marked in red and green respectively.

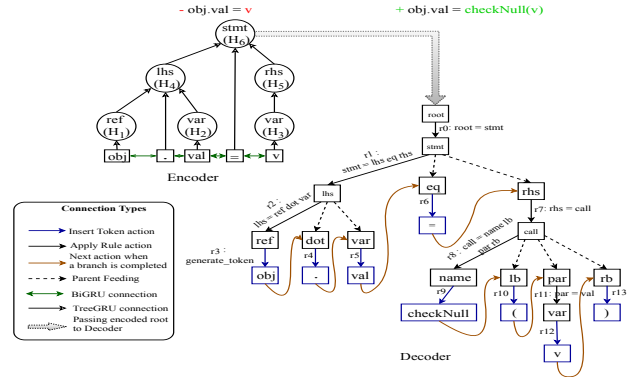

(b) Encoding & Decoding the parse trees using tree-to-tree neural machine translation.

Fig. 1: Motivating Example

frontier node. Thus, in Figure 1(b), `root` is first expanded to its left most subtree: `root` \rightarrow `stmt` \rightarrow `lhs` \rightarrow `obj_ref` \rightarrow `obj`. At each step, depending on the frontier node type, either of the two operations are performed:

- (i) For a *non-terminal node*, e.g., `stmt`, it recursively generates child non-terminals till a terminal node is reached. The tree generation is guided by Java grammar rules (e.g., `r1`, `r2`, etc.).
- (ii) For a *terminal node*, it generates the token value (e.g., rule `r3`).

At each step of the tree generation process, we probabilistically apply Java grammar rules. The probabilities are learned during the training process. Each step is performed to maximize the probability distribution $p(T|S)$. Applying these actions sequentially from the root (`r0`, `r1`, ..., `r13` in the Figure), will yield a complete target tree T .

IV. TREE2TREE NEURAL TRANSLATION MODEL

Our tree2tree NMT model consists of two main parts: an encoder and a decoder. In this section, we will discuss each of these steps in details.

A. Encoder

For encoding the source tree S , we adopt a Tree-based GRU model originally developed to translate text from English to Chinese [36]. It follows two different schemes to encode the terminal and non-terminal nodes.

1) *Encoding Terminal Nodes*: The terminal nodes of S form a token sequence, say w_1, w_2, \dots, w_n . For example, in Figure 1(b), the token sequences for the source tree are (`obj`, `.`, `val`, `=`, `v`). At first, similar to Bahdanau *et al.* [30], for each token, we compute the hidden vector representation that contains information about itself and the tokens that precede and follow it. To compute this, we deploy a bidirectional GRU (biGRU) [37] that employs two Gated Recurrent Unit (GRU), one in forward direction (f) and another in backward direction (b). The biGRU computes a distributed vector representation of token w_i such that: $h_i = [h_i^f, h_i^b]$ where, h_i is the concatenation of the vectors computed by the forward and backward GRUs and represents the token-level information of the terminal nodes of the tree S .

2) *Encoding Non-Terminal Nodes*: For each non-terminal node, we compute the hidden representation from its children nodes' representations recursively using a TreeGRU [38] (Equation (1)) until the root node is reached. For instance, to compute the representation of a node n with children $C = [c_1, c_2, \dots, c_k]$, we compute the hidden representation $H(n)$ using the following equation:

$$H(n) = \begin{cases} h_i & \text{if } n \text{ is a terminal node} \\ E(C) & \text{if } n \text{ is non-terminal node} \end{cases} \quad (1)$$

Where the encoding function E is defined as:

$$E(C) = \begin{cases} H(c_1) & \text{if } |C| = 1 \\ f(W_L^e \cdot H(c_1) + W_R^e \cdot E(c_2, \dots, c_k)) & , \text{otherwise} \end{cases} \quad (2)$$

Here, $f(\cdot)$ is a non-linear activation function. We used `tanh` in our implementation. W_L^e and W_R^e are two matrices, which are also learned during the training. We calculate the hidden representation of root H_{root} following Equation (1) (H_6 in Figure 1(b)), which essentially encodes the whole source tree.

B. Decoder

From the intermediate representation, say s' , produced by the encoder, the decoder generates the target tree (T). For a non-terminal node, it generates a subtree, and for a terminal node, it generates its value. The tree generation is guided by Java grammar rules whose probability we learn from the training process. At each step of the tree generation, we probabilistically apply these rules.

1) *Applying Grammar Rules*: We adopt Yin *et al.*'s [32] probabilistic grammar model that represents the tree generation process as a sequence of two types actions: `ApplyRule` and `InsertToken`. While the former defines how a tree structure is generated, the later defines how the terminal nodes are populated with token values.

At a given step t during the tree generation process, we expand the bottom-most and left-most node of the current tree. We call such node as *frontier node* (n_t^f). The tree generation starts from the root node (see Figure 1(b)). Thus, at the beginning ($t = 0$), `root` is the frontier node. We maintain

a pointer to the frontier node which updates at every step. At each time step, the frontier node is expanded using one of the following *actions*:

(i) **ApplyRule(r)**: This action generates the tree structure by expanding the frontier node (n_f^t) in a depth-first, left-to-right fashion. From the fixed set of Java grammar rules \mathcal{G} , ApplyRule selects a rule r to expand n_f^t . In Figure 1(b), r_0, r_1, r_2, r_7 , and r_8 show these rules.

(ii) **InsertToken(v)**: At any time instance t , if the frontier node(n_f^t) is a terminal, this action is applied. It selects a token (v), probabilistically, either from the vocabulary or the source code and puts v as a value of n_f^t . Then it removes n_f^t as frontier node marking that branch of derivation as fully derived and proceeds on to the next frontier node.

Applying these rules sequentially from the root will yield a complete parse tree. In Figure 1(b), rules r_0 to r_{13} are sequentially applied to generate the final tree. At each step, the rules are selected probabilistically.

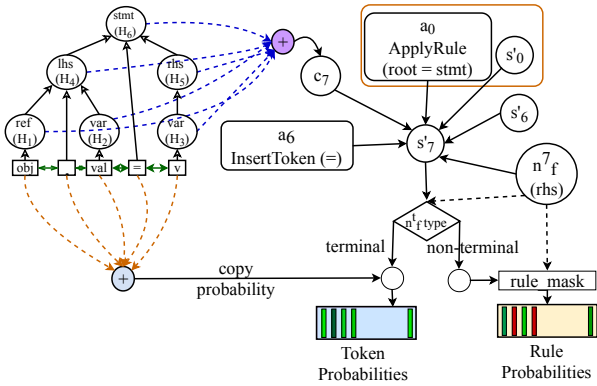

Fig. 2: Detailed view of Decoding Scheme at step t_7 (corr. to rule r_7) from Figure 1(b). Here, frontier node (n_f^t) is rhs , parent node is $stmt$ at t_0 . To generate hidden state s_7^t , actions at a_0 and hidden representation at t_0 i.e. s_0^t are also fed to the decoder. Also, previous action a_6 , context vector c_7 , and frontier node n_7^t are fed to the decoder. s_7^t is used to compute token and rule probabilities.

2) *Decoding Scheme*: A decoder generates a target tree (T) given a source context (S). The probability of the final tree, conditioned on a context S is:

$$p(T|S) = \prod_{t=1}^{\tau} p(a_t|S, a_1 \dots a_{t-1}) \quad (3)$$

where a_t is the action at time step t . At any time step t , the probability of a_t is not only dependent on the context (S), but also on the previously taken actions $a_1 \dots a_{t-1}$. Note that, the source context S generates an intermediate representation s^t (encoder's output), which is actually taken by the decoder as input. P is calculated by the decoder as explained below. All the intermediate computations are summarized in Table I.

The core of the decoder is an LSTM that generates hidden state s_t^t at step t . There are five inputs to the decoder LSTM: (i) the action at previous time step (a_{t-1}), (ii) the action at parent node (a_{p_t}), (iii) the hidden state at parent node ($s_{p_t}^t$), (iv) current frontier node (n_f^t), and (v) a context vector

generated by attention mechanism (c_t). Figure 2 shows this step in details.

At each step t , the decoder updates its hidden state using LSTM Equation (4) (see Table I). On top of a vanilla LSTM, we use soft attention over the source hidden vectors of all node representations ($\{H(n)\}$) to compute the context vector c_t . We use the hidden state (s_t^t) subsequently to compute several probability distributions, as shown Table I.

Next, the decoder checks the type of the frontier node. If it is a non-terminal node, it applies rules to expand the tree. Otherwise, a token value is selected.

Applying Grammar Rules: At each step of the tree generation, we probabilistically apply the grammar rules. Equation 5 in Table I gives a probability distribution over all grammar rules at time t . $mask_r(n)$ is a function that provides a Boolean mask for filtering out disallowed rules depending on the type of node n_f^t . This mask function is a property of the Java Grammar \mathcal{G} and can be statically pre-computed. We then pick an action a_t from $p(a_t = ApplyRule(r = \hat{r})|S, a_1 \dots a_{t-1})$ by sampling from the discrete probability distribution given by equation 5. If the model chose to select InsertToken action, we either select token from the vocabulary or copy token from source S . Relevant probability distributions are given by Equation (6) in Table I.

Copying: In contrast to Yin *et al.*, that is learning to generate code given natural language as input, we can take advantage of the fact that tokens that appear in source S will also appear in target T . To use this fact, we turn to copying mechanisms, originally proposed by Vinyals *et al.* [39]. It is a neural architecture to learn the conditional probability distribution of an output sequence to positions in an input sequence. It uses an attention mechanism as a pointer to select input token to be copied to the output sequence. The conditional probability of an input token being copied to output sequence is given by Equation (7). Here, $\omega(\phi)$ refers to the function of a deep feed-forward neural network with input ϕ . Equation 7 gives a probability distribution over all tokens in the input sequence. We use this probability to add to final probability of an output token.

Since we are dealing with code changes, not all the tokens from the source should be copied. We wanted to let the model generate some tokens as well. We let the model learn the probability that tells us when to copy. The model calculates that probability as $p(copy_t|S, a_1 \dots a_{t-1})$ Equation (8). Finally, marginalizing over the two token generation mechanisms together,

$$\begin{aligned} p(a_t = InsertToken(v = \hat{v})|S, a_1 \dots a_{t-1}, n_f^t) \\ = (1 - p(copy_t|S, a_1 \dots a_{t-1})) * p(v = \hat{v}|S, a_1 \dots a_{t-1}, n_f^t) \\ + p(copy_t|S, a_1 \dots a_{t-1}) * p(w = \hat{v}|copy, S, a_1 a_2 \dots a_{t-1}) \end{aligned} \quad (9)$$

The probability distribution for action at time t becomes:

Task		Computation
Generating hidden state s'_t using LSTM at time t		$s'_t = f_{LSTM}([a_{t-1}, a_{p_t}, s'_{p_t}, n_f^t, c_t], s'_{t-1})$ (4)
Probabilities related to Grammar rules	ApplyRule(r) at time t	$p(r S, a_1...a_{t-1}, n_f^t) = softmax((E_R \cdot (W_R s'_t + b_R) \cdot mask_r(n_f^t)))$ (5)
	InsertToken(v) at time t	$p(v S, a_1...a_{t-1}, n_f^t) = softmax(E_V \cdot (W_V \cdot s'_t + b_V))$ (6)
Probabilities related to Copy	Copying from input	$p(w_i copy, x, a_1 a_2...a_{t-1}) = \frac{exp(\omega(h_i, [s'_t, c_t]))}{\sum_{j=1}^{j=n} exp(\omega(h_j, [s'_t, c_t]))}$ (7)
	Decision of copying	$p(copy_t S, a_1...a_{t-1}) = softmax(W_C \cdot s'_t)$ (8)

TABLE I: Intermediate computations used in Decoding. Model parameters E_R , W_R , E_V , and b_R are optimized during training.

$$\begin{aligned}
 p(a_t|S, a_1...a_{t-1}) = & \\
 \begin{cases} p(a_t = ApplyRule|S, a_1...a_{t-1}, n_f^t) & \text{if } n_f^t \text{ is non-leaf} \\ p(a_t = InsertToken|S, a_1...a_{t-1}, n_f^t) & \text{if } n_f^t \text{ is leaf} \end{cases} & \quad (10)
 \end{aligned}$$

V. IMPLEMENTATION

Using our tree2tree NMT model, we implement a source code suggestion tool, CODIT. CODIT learns source code changes from a pool of patches in the wild. Then, given a code fragment to modify, CODIT predicts potential changes that are likely to take place in the similar context. We implemented CODIT using Theano on top of Python 2.7. This section elaborates CODIT implementation, *i.e.* our patch processing, training, and testing approaches in detail.

Patch Pre-processing. As a first step of the training process, CODIT takes a pool of patches as input and represent them in parse tree format. CODIT works at method granularity. For a method patch Δm , CODIT takes two versions of m : m_{src} and m_{tar} . CODIT uses GumTree, a tree-based code differencing tool [40], to identify the edited AST nodes of the two versions. The edit operations are represented as insertion, deletion, and update of a node *w.r.t.* m_{src} . CODIT then selects a minimal subtree of each AST that captures all of its edited nodes. For example, in Figure 1(a), **red** nodes are identified as deleted nodes and **green** nodes are marked as added nodes. If size of this tree exceeds a maximum size (max_change_size), we reject this patch from consideration.

CODIT further collects the edit context by including the nodes that connect the root of the method to the root of the changed tree. CODIT continues expanding context until the whole tree exceed a maximum tree size(max_tree_size). For example, in Figure 1(a), it includes the dotted sub-trees as context. In the process, CODIT excludes any changes occurred in JavaDoc, comments, and constants. Finally, for each method pair, CODIT gets a pair (AST_{old}, AST_{new}) where AST_{old} is the original AST where change was applied, and AST_{new} is the AST after the changes.

CODIT then converts the ASTs to the parse tree representation. In AST, non-terminals can hold values. For our model, we only want terminals to hold values so that they can form token

sequences. Hence, CODIT converts the AST to a parse tree representation. Thus, the final pair of parse trees representing a patch is (PT_{old}, PT_{new}) .

To evaluate the model, we first sorted the patches of our dataset chronologically. Then, we took the first 75% of the patches from each project as training, 15% as validation, and the rest 10% as testing. This way of partitioning the data reflects how a developer would use a model in real life: a model trained on past patches will be used to predict future edits.

Model Training. The objective of this step is to optimize the parameters of the network to maximize the probability estimation of Equation (3). First, we used the cross-entropy loss as the objective function. However, in our preliminary experiment, we found that the quality of the generated code is not directly related to the loss. To mitigate this problem, we used BLEU score [41], a standard metric to evaluate translation models, as an alternate way of evaluating the trained model. We run the training model for a fixed amount of time (n_{epoch}). However, if the model performance (in terms of BLEU score) on validation data does not improve consecutively over a fixed number of steps ($valid_patience$), we stop training procedure and declare the best-resulting model as the target model.

Model Testing. To test the model and generate changes, we adopt a beam-search-based approach [42]—instead of generating one target tree, at each step of the decoder, we generate K (partially generated-) trees. In beam search’s terminology, these are states/hypotheses. At each time step, we pick the top K partial expansions. Then, we explore all states by all possible expansions reachable from those K states. If we find a state that is completed (*i.e.* a state containing a complete tree), we exclude that hypothesis from further expansion. We then pick top K incomplete hypotheses based on the score. We stop this process if max time step is reached or if there is no more incomplete hypothesis to be expanded. We then sort all completed hypotheses based on the probability score. Finally, we generate K different code fragments from K different hypotheses.

VI. EVALUATION

We first discuss our experimental design followed by the results.

A. Experimental Design

Data Collection. We chose 48 open source projects from GitHub to train our model. These projects are from the TravisTorrent dataset [24] and have at least 50 commits in at least 1 *java* file. For each project, we collected the revision history of the main branch. We further collected the revision history from all six projects of Defect4J [43] dataset. For every commit in those projects, we collected both before commit and after commit version of any java file that is affected by that commit. We have in total 2,41,976 file pairs. We then extracted a list of method pair affected by the changes by analyzing the file pairs. We trivially reject any method pair, where change is only in comments or in JavaDocs. Rest method pairs are input to CODIT’s pipeline. We set $max_change_size = 10$ and $max_tree_size = 20$ as CODIT’s patch pre-processing parameters. After analyzing and filtering, we have 44,382 total patches in total.

For each method patch, we created an abstract patch to evaluate CODIT’s ability to suggest the abstract patches. We first analyzed the patched ASTs (AST_{old}, AST_{new}) (see Section V), and created a symbol table. Next, we replaced each identifier name by a symbolic name and stored the corresponding original names in the symbol table. Thus, these abstracted patch trees retain the edit structure. With such abstraction, the vocabulary size is reduced to 118 (total vocabulary size is 32,000 in original dataset) which significantly improves sparsity.

Evaluation Metric. To evaluate the learning capability of CODIT, we check that given a code fragment, how accurately CODIT can generate abstract and concrete patches. We consider CODIT has correctly generated a patch if it generates the exact code as the original, *i.e.* the distance between generated and original target trees is 0. We let CODIT produce K patches, where K is the beam size. These are the *top K* patches suggested by CODIT in our evaluation setting. Then we compute CODIT’s accuracy as how many patches are correctly generated in top K . Note that this metric is stricter than semantic equivalence.

Baseline. We built a Seq2Seq model on top of OpenNMT [44], an open source library for neural machine translation. We also used soft-attention mechanism in our baseline as described by Bahdanau *et al.* [30]. To train our baseline, we used the same dataset as we used to train CODIT in the respective scenario. During testing of concrete patches, we allowed `replace_unknown` flag to replace any instance `<unknown>` token generated with the source token that had highest attention weight.

B. Results

To develop CODIT, we faced many design choices. We start with systematically evaluating them.

RQ1. How do different design choices affect CODIT’s performance?

Table II summarizes our different design choices related to abstract and concrete patch generation.

Top 1			Top 10		
Generating Abstract Patches					
Seq2Seq + Token	Seq2Seq + Token type	Tree2Tree + Token	Seq2Seq + Token	Seq2Seq + Token type	Tree2Tree + Token
300	444	608	743	887	1567
Generating Concrete Patches					
Copy + Mask	Copy + No_Mask	No_copy + No_Mask	Copy + Mask	Copy + No_Mask	No_copy + No_Mask
225	225	157	374	372	157
Number marked in red reflects best performing choice at that setting.					

TABLE II: Evaluating Different Design Choices

Abstract Patch. We experimented with following code abstractions and models:

(i) *Seq2Seq + Token*: We start with simply tokenizing the code. For example, a code fragment `return fit(new Gaussian.Parametric(), guess)` is expressed as `return t3 (new t1 () , t2)`. We choose this abstraction because many language models could successfully generate code with this abstraction [25]–[27]. Then, we applied our vanilla Seq2Seq model as described in Section VI-A. In this setting, we found 300 and 743 correct patches out of 6735 total patches in top 1 and top 10 respectively.

(ii) *Seq2Seq + Token Type*: Next, we consider the AST types of the identifier names. For instance, the code fragment shown above is treated as `return METHOD_1 (new PACKAGE_1 () , VAR_1)`. Table II shows the result: 444 and 887 correct patches are correctly suggested in top 1 and top 10 respectively.

(iii) *Tree2Tree + Token*. Next, we use `tree2tree` model on abstract code fragment to generate abstract patches. Depending on the configuration, CODIT produces three types of abstract patches: without identifier names (tree only), with abstracted names, and with token types. In first case, CODIT only predicts the tree. This allows CODIT to predict any structural changes. With this configuration, CODIT predicted 2022 patches correctly in top 10. The second configuration consists of dataset where token names are replaced abstract symbolic token names. (*i.e.* `t1, t2` etc.). With this configuration, CODIT predicted 1567 correct patches in top 10. The third and the final configuration consist of a dataset where token names are replaced by token types. In this configuration, CODIT predicted 650 correct patches in top 1 and 760 in top 10.

Although CODIT performs best while predicting only the tree, we choose to present the results with abstracted tokens in rest of the paper as that will give us an opportunity to compare the vanilla Seq2Seq model on a fair ground. At this setting, CODIT suggests 608 correct abstract patches at top 1 and 1567 correct patches at top 10.

Concrete Patches. With concrete dataset, the vocabulary size explodes. To keep the model tractable, we had to use a

threshold of maximum vocabulary size. However, the concrete dataset vocabulary is much larger than that of the maximum vocabulary size. The out of vocabulary tokens are replaced by special `<unknown>` token, similar to most NLP models. When we applied a `no_copy + no_mask` setting (See Section IV-B), 157 correct patches are suggested in both top 1 and top 10. A lot of the patch suggested in this setting had `<unknown>` token in the generated code.

Next, with copying technique (see section IV-B), *i.e.* `copy + no_mask`, CODIT predicted 225 correct patches in top 1 and 372 in top 10. We further tested CODIT with applying a token mask to filter out impossible out-of-scope tokens (`copy + mask`). CODIT resulted in slightly better results (*e.g.*, 374 correct patches in top 10) than results with (`copy + no_mask`). Thus, as a final model for generating concrete patches, we used “copy + mask” settings. Note that, the `mask` we discuss here is not the same mask discussed in section IV. Instead, this token mask depends on the type of the terminal node and is statically pre-computed.

Trained Model Type	% of correct patches in Top				
	1	2	5	10	20
<i>Model_{ppl}</i>	8.29	11.58	20.04	23.1	26.16
<i>Model_{bl}</i>	9.03	14.54	19.90	23.27	26.53

TABLE III: Percentage of correct abstract test patches generated by CODIT with varied beam sizes.

We further evaluate CODIT’s ability to suggest correct abstract patches *w.r.t.* two models: (i) the model with best perplexity (*Model_{ppl}*) in validation dataset, (ii) the model with best BLEU in validation dataset (*Model_{bl}*). Table III shows the percentage of correct patches generated by the two models.

Although, the two models perform similarly, *Model_{bl}* performs slightly better than *Model_{ppl}*. Thus, in subsequent evaluations of this paper, we use *Model_{bl}*.

Result 1: A Tree-to-Tree model works best for abstract patch generation and for concrete patch generation it works better with copying and masking technique.

With the best performing settings, next we evaluate:

RQ2. How accurately CODIT can suggest abstract edits?

To evaluate this RQ, we evaluate CODIT’s accuracy *w.r.t.* to a data set containing abstract patches (*i.e.* with abstracting away the identifier names). Table IV shows the result. CODIT can correctly generate 608, 979, 1340, 1567, and 1787 abstract patches out of 6735 total patches with beam size 1, 2, 5, 10 and 20 respectively. Thus, CODIT can generate up to 26.53% abstract patches with beam size 20.

CODIT vs. Seq2Seq. We further compare CODIT’s performance to generate abstract patches with a vanilla Seq2Seq model, as described in VI-A. Table IV shows the result. Across all the beam sizes, CODIT performs significantly better than the Seq2Seq model. For instance, at Top 1, CODIT finds the correct patch with 9.03% accuracy, while Seq2Seq has

4.45% accuracy. The difference increases further with larger beam size. For example, at beam size 20, CODIT’s accuracy is 26.46% while Seq2Seq’s accuracy is only 13.43% respectively. Thus, overall, we see a gain of around 103%, 194%, 175%, 110%, and 97% at beam sizes 1, 2, 5, 10 and 20 respectively.

Table V further shows some examples to illustrate the difference between the two models. Note that, as described in section VI-A, here our baseline is a vanilla Seq2Seq model that works on a sequence of tokens. Thus, we also asked CODIT to produce patches with the same abstraction, for fair comparison.

Ex1 shows an instance of statement deletion that CODIT is able to successfully suggest. The Seq2Seq model suggested a patch, which is syntactically correct but not the right patch. In case of Ex2, both CODIT and Seq2Seq successfully generated correct patch. Ex3 shows a patch where Seq2Seq could generate successful patch but CODIT could not. The best CODIT did here removing the parameter from `t2`’s constructor. However, the correct patch contains a different API `t3`.

Variation of performance with edit size. We further noticed that, with different edit sizes CODIT’s performance varies. To estimate how CODIT’s performance varies with edit sizes, for each patch in our test dataset, we calculate the tree edit distance between the corresponding source and target tree [45], [46]. We then divide the distances into 3 bins: (*small*: `edit_size = 1`, *medium*: `2 ≤ edit_size ≤ 5`, and *large*: `6 ≤ edit_size ≤ 10`) and analyze the CODIT’s performance. As shown in Table IV, CODIT performs better at smaller edit sizes. For example, at beam size 20, for `edit_size = 1`, CODIT correctly suggests 1358 edits out of total 3368 edits (40.32% accuracy). In contrast, at the same beam size, the CODIT’s accuracies at medium and large edit sizes are: 11.01% and 15.46% respectively. Similar trend is observed across all the beam sizes and also for the Seq2Seq model.

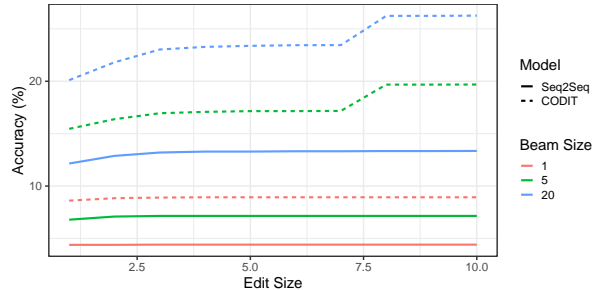

Fig. 3: Variation of performance with edit sizes. The figure shows a cumulative plot of how the percentage of correct (abstract) patches vary with different edit sizes across different beam sizes. All the percentage numbers are calculated *w.r.t.* total patches.

Figure 3 further shows the variation of accuracy with edit sizes using a cumulative plot. Here, the accuracy at each edit size are measured *w.r.t.* the total patches in the evaluation set. The figure shows that at beam size 1 (orange lines), the accuracy of CODIT is 8.61% and then remains almost constant with the larger edit sizes. In contrast, at beam size 20 (blue lines), CODIT starts with an accuracy of 20.11% and then

Edit Sizes	#Examples	Top 1		Top 2		Top 5		Top 10		Top 20	
		CODIT	Seq2Seq	CODIT	Seq2Seq	CODIT	Seq2Seq	CODIT	Seq2Seq	CODIT	Seq2Seq
1	3368	586	299	785	330	1043	460	1208	704	1358	818
2 - 5	2061	22	1	59	3	119	27	168	39	227	87
6 - 10	1306	0	0	135	0	178	0	191	0	202	2
Total	6735	608	300	979	333	1340	487	1567	743	1787	907
		9.03%	4.45%	14.54%	4.94%	19.90%	7.23%	23.27%	11.03%	26.53%	13.47%
Gain ($\frac{CODIT-Seq2Seq}{Seq2Seq}$)		102.92%		194.33%		175.24%		110.97%		96.96%	

TABLE IV: Performance of CODIT suggesting abstract patches

Ex1. Correctly suggested by CODIT but not by Seq2Seq
<pre>src: public t3 () { t2 (); t4 . t1 (STR); } tar: public t3 () { t2 (); t4 . t1 (STR); }</pre>
<pre>t2t: public t3 () { t2 (); t4 . t1 (STR); } ✓ s2s: public bool t3 () { t1 . t2 (STR) ; } ✗</pre>
Ex2. Correctly suggested by both CODIT and Seq2Seq
<pre>src: private t1 () { } tar: private t1 () { super(); }</pre>
<pre>t2t: private t1 () { super(); } ✓ s2s: private t1 () { super(); } ✓</pre>
Ex3. Correctly suggested by Seq2Seq but not by CODIT
<pre>src: { return new t2 (new t1 (null , true)) ; } tar: { return new t1 (null , true) t3 () ; }</pre>
<pre>t2t: { return new t1 (null , true) t2 () ; } ✗ s2s: { return new t1 (null , true) t3 () ; } ✓</pre>

TABLE V: Example Patches generated by tree2tree vs. seq2seq model

gains slowly up to 26.26% for edit size 10. It gains steadily till edit size 3, and then almost remains flat till edit size 7. It again gains accuracy at edit size 8 and then remains almost constant after that. CODIT follows a similar trend for beam size 5. There is a sudden boost in performance at edit size 8. We surprisingly found that, a large number of candidate patches in our test dataset are of same type. CODIT could successfully suggest all those edits. Seq2Seq model have a similar trend but at a much lower rate. Thus, we see that, in general, CODIT is better suited for suggesting smaller patches (1-3 edit sizes) rather than the larger ones.

Since we are performing well at smaller edit sizes, one could imagine that we are only good at suggesting trivial changes. To check that we ignore the patches with token renaming and then compare CODIT’s accuracy with the rest of the patches (3439 in total). We find that we could still predict 9.68% to 18.32% patches from beam size 1 to 20.

These results prove that CODIT can suggest abstract patches with good accuracy. Such patches can be used by the developers as change templates (similar to refactoring templates provided by modern IDEs).

Result 2: CODIT can suggest 26% of the abstract

changes at top 20 and significantly outperforms its Seq2Seq alternative. For single node changes, CODIT can correctly suggest as much as 40% patches.

RQ3. How accurately CODIT can suggest concrete edits?

To answer this RQ, we evaluate CODIT’s accuracy *w.r.t.* the evaluation dataset containing concrete patches. Table VI shows the results: CODIT achieves 3.34%, 4.13%, 5.11%, 5.52%, and 6.33% accuracy in suggesting top 1, 2, 5, 10, 20 patches respectively. CODIT outperforms its Seq2Seq alternative by 35.77%, 42.41%, 39.24%, 39.39%, and 42.35% in suggesting concrete patches at top 1, 2, 5, 10, and 20 respectively.

Table VII shows some examples where CODIT can successfully generate the concrete patches. For instance, in Ex1, CODIT successfully removes a typecasting `CraftInventory`. In Ex2, CODIT removes a whole statement from the `if` block. Ex3 and Ex4 further show cases where CODIT successfully adds a parameter `true` to a method call and adds a generic respectively.

To gain a better insight of the kind of patch CODIT can successfully generate, we further investigate the cases where CODIT could predict correct concrete patches but Seq2Seq could not—there are 216 such cases at beam size 20. We manually investigated all those patches and assigned a category of the patch considering the change type. The categorization was done by two authors. The lead author first assigned the category, and then another author reviewed them. In case of disagreement, they discussed and came to an agreement. Table VIII shows the results.

We notice that the most common patches are related to final keywords: 77 times CODIT could successfully add or remove them. The next highest category is related to change to method parameters (see Ex3 in Table VII). The other categories are related to changing types, method modifier, and APIs. In total, CODIT successfully generated patches in 9 different categories. This results show CODIT is applicable to different types of edits.

Inspite of these successes, performances of both CODIT and Seq2Seq model are much lower than that on the abstract dataset because while with concrete dataset the models face an explosion of vocabulary (vocab size around 32000 in original dataset and 118 in abstract dataset). The token names in concrete edits are so diverse that, even with copying mechanism CODIT achieved lower performance. For instance, `decrStackSize (k , itemsToExtract)`

Edit Sizes	#Examples	Top 1		Top 2		Top 5		Top 10		Top 20	
		CODIT	Seq2Seq	CODIT	Seq2Seq	CODIT	Seq2Seq	CODIT	Seq2Seq	CODIT	Seq2Seq
1	3368	60	5	101	15	124	64	138	76	170	94
2 - 5	2061	9	2	21	4	60	6	73	12	95	21
6 - 10	1306	156	159	156	176	160	177	161	179	161	185
Total	6735	225	166	278	195	344	247	372	267	426	300
		3.34%	2.46%	4.13%	2.90%	5.11%	3.67%	5.52%	3.96%	6.33%	4.45%
Gain ($\frac{CODIT-Seq2Seq}{Seq2Seq}$)		35.77%		42.41%		39.24%		39.39%		42.25%	

TABLE VI: Performance of CODIT suggesting concrete patches

Ex1. Removing Type Cast

```
...s = (CraftInventory) user.getInventory()...;
```

Ex2. Removing Statement

```
if(command.matches(STR)) {
  user.sendMessage(STR);
  return;
}
```

Ex3. Adding Method Parameter

```
item.setArrived(true);
```

Ex4. Adding Generic

```
Service<?> service
```

TABLE VII: Example Concrete Patches generated by CODIT

Patch Category	# of correct patch by CODIT
Changes related to <i>final</i> keyword	77
Method parameter change	45
Type related change	24
Method modifier change	20
API Change	10
Bracket Change	8
Expression change	2
Statement change	4
Other (misc.)	26

TABLE VIII: Performance of CODIT suggesting patches

`count`) was incorrectly predicted as `decrStackSize(k, itemsToExtract() k)`, while the corresponding abstract patch was suggested correctly.

Thus, it is often the case that the variable name CODIT generated is incorrect, however the rest of the patch is fine. To estimate how far we are from generating the correct concrete patches, we further compute *patch distance*: edit distance between a patch produced by an NMT model and the ground truth. Such patch distance can be an estimate of developers' effort to fix the *near-miss* patches (e.g., patch distance 1 means developers have to add/delete/change only 1 token). Figure 4 shows the result up to patch distance 5.

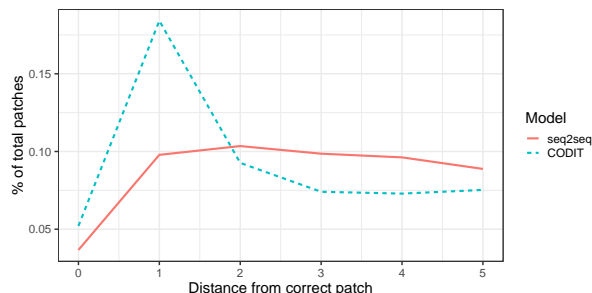

Fig. 4: Histogram of Patch distances (distances between the model generated and ground truth patches)

While CODIT can generate only 5% patches correctly (patch distance=0) at top 5, there are 18% and 9% patches that are within 1 and 2 patch distances from the ground truth. Compared to Seq2Seq model, CODIT can generate around two times more patches within patch distance 1 (659 in case of Seq2Seq and 1204 in case of CODIT). Overall, CODIT can generate around 28% of near-miss patches within patch distance 1 and 2; we believe these patches can be easily adapted by the developers.

Result 3: CODIT can suggest around 5% correct patches within top 5 and outperforms Seq2Seq model by 39%. CODIT can also suggest 28% near-miss patches.

Since bug-fixing is a special type of code change, we also evaluate:

RQ4. How accurately CODIT suggest bug-fix patches?

We evaluate this RQ with state of the art Defects4J [43] dataset. Since we are interested in testing the viability of using CODIT for bug-fix patches, we assumed the bug-fix locations are already given to us as an input.

Training: We evaluated CODIT on six Defects4J projects. We collected the commits from the projects' original GitHub repositories and preprocessed them as described in Section V. We trained our model based on this dataset.

Testing: We extract the methods corresponding to the bug location(s) from the buggy-versions of the Defect4J dataset. One bug can be fixed across multiple methods. We consider each of those methods as a candidate for testing. We extract ASTs from these buggy methods. We then filter out the methods that are not in between our minimum and maximum tree sizes. In that way, we got 117 buggy method-ASTs corresponding to 80 bugs in Defects4J. Rest of the bugs are out of our scope. Here, we set the beam size = 200. Note that, a larger beam size is not a problem here because software test suite will automatically discard the unwanted patches.

CODIT successfully generated the fixes for 22 buggy ASTs corresponding to 10 bug ids. These are all concrete patches. Among 8 of those 10 bug ids, CODIT generated fixes for all the buggy ASTs (i.e. 10% of the studied bugs). For other two bug ids, CODIT generated partial fixes.

Table IX further shows all the patches that CODIT can successfully generate. For all the bugs marked in **green**, CODIT successfully fixes all the underlying buggy methods. For example, Math-49 has 4 buggy methods, CODIT fixes all the four. For the bugs marked in **blue**, CODIT fixes all the

BugId	#methods to be patched	#methods in scope	#methods CODIT can fix	Patch Type
Time-4	1	1	1	reorder method-call parameters
Time-26*	7*	7*	6*	remove method-call parameters*
Math-46	2	2	2	change ternary statement
Math-49	4	4	4	update API
Math-58	1	1	1	remove method-call parameters
Lang-26	1	1	1	remove method-call parameters
Lang-46†	6†	4†	4†	multiple change patterns†
Lang-60*	2*	2*	1*	modifies control loop*
Closure-9†	2†	1†	1†	multiple change patterns†
Closure-86	1	1	1	changes boolean value

Green rows are bug ids where CODIT can produce complete patch. Blue† rows are where CODIT can fix all the methods that are in CODIT’s scope. Orange* rows are where CODIT could not fix all that are in CODIT’s scope.

TABLE IX: Summary of CODIT’s performance on fixing bugs using Defects4J Dataset.

methods that are in scope. For example, for Lang-46, there are 6 methods to be patched, 4 of them are in CODIT’s scope, and CODIT fixes them. However, for other two bugs (marked in orange*), CODIT produces only partial fix. For example, in the cases of Time-26 and Lang-60, although all the methods are within scope, CODIT could fix 6 out of 7 and 1 out of 2 methods respectively. The ‘Patch Type’ column further shows the type of change pattern for those patches.

In a recent paper, Saha *et al.* [47] showed that they could fix 11.93% Defects4J bugs (26 out of 218). They had 8 pre-defined fix patterns and applied those patterns to fix the bugs. Similar pattern based bug-fixing approaches are also proposed in the past [48]. CODIT can be viewed as a transformation schema which automatically learns these patterns without any human guidance. In fact, CODIT can fix three bugs that are also fixed by Saha *et al.* Additionally, CODIT can generate 2 (Math-46, Math-49) more complete fixes and 1 (Lang-46) partial fixes. Thus, without any human guidance, CODIT can complement state-of-the-art program repair tool’s performance.

One thing to note here is that, CODIT is not explicitly focused on bug-fix changes, it is trained with generic changes. Even with that, CODIT achieved good performance in fixing Defects4J bugs. Thus, we believe CODIT has the potential to complement existing program repair tools by customizing the training with previous bug-fix patches and allowing to learn from larger change sizes. We leave that as part of our future research.

Result 4: CODIT can be a viable way of identifying common bug-fix patterns and can be applied to fix bugs.

VII. THREATS TO VALIDITY

External Validity. We built and trained CODIT on real-world changes. Like all other machine learning models, our hypothesis is dependent on the dataset which may not generalize. To mitigate this threat, we collected patch data from different repositories. To mimic the real development scenario, we split the curated patches to train, validation, and testset chronologically. We further made sure that the test set contains patches from all the projects.

Internal Validity. We used BLEU [49] score as a guidance to our training process. However, a recent paper [49] showed the ineffectiveness of BLEU score outside of machine translation model. However, unlike NLP, we did NOT use machine translation BLUE score to evaluate our model. Instead, we used the most stringent metric (*i.e.* identical patches) in assessing CODIT. Thus, we minimize the threat involving BLUE score.

Similar to other ML techniques, CODIT’s performance depends on hyperparameters. To minimize this threat, we tune the model in validation step. Also, to check for any unintended implementation bug, we frequently probed our model in a running experiment and tested for desirable qualities.

VIII. RELATED WORK

Modeling Source code. Applying machine learning to source code artifacts has been receiving increasing attention by the research community [22]. These models find many applications, such as code completion [11], [25], bug prediction [50], [51], clone detection [52], code search [53], *etc.* Here we investigate how to model code changes which is fundamentally different than modeling code.

Machine Translation (MT) for source code. MT was previously used for source code translation [54], especially for translating code from one programming language into another [55]–[57]. These works primarily used Seq2Seq model at different code abstractions. In contrast, we propose a syntactic tree-based model. More closely to our work, Tufano *et al.* [23] showed initial promise of using Seq2Seq translation model with attention mechanism for program fixing. Their model is similar to our “Seq2Seq +token types” in Table II. We showed a tree2tree model outperforms this setting with a large margin. Gupta *et al.* further used simple Seq2Seq models to fix C syntactic errors [58]. However, 50% of their patches were syntactically incorrect which is never the case for us because of using tree-based approach.

Program Fixing. Automatic program repair is a well-researched field [48], [59]–[62]. There are two main directions to fix bugs: generate and validate approach [48], [63], [64], and synthesis based strategies [65], [66]. CODIT falls in the former category where it predicts a possible patch by learning from the wild. Researchers applied conceptually similar strategies by searching for the fixes from existing code base [63], [67]. Le *et al.* [68] further utilized the development history as an effective guide in program fixing. The key difference between Le *et al.* and this work is that instead of mining change patterns we learn a probabilistic model that learns and generalize the patterns from the training data.

Automatic Code Changes. Modern IDEs [7], [8] provide limited support of automatic editing like refactoring, adding boilerplate templates (*e.g.*, try-catch block) *etc.* There are many research work on automatic and semi-automatic [69], [70] code changes. For example, given that similar edits are often applied to similar, if not identical, code context, Meng *et al.* [19], [21] propose to generate the repetitive edits using code clone analysis, sub-graph isomorphism, and dependency analysis. Other approaches mine past changes from software

repositories and suggest edits that were applied previously to similar contexts [2], [3]. Unlike these approaches, CODIT can generate edits by learning changes from the wild—it neither requires similar edit examples to learn from nor similar edit contexts where the edits can be applied.

Romil *et al.* [20] propose a program synthesis-based approach to generate edits where original and modified code fragments are the input and output to the synthesizer. Such patch synthesizer can be thought of as a special kind of model that takes into account additional specification such as input-output examples or formal constraints. In contrast, in this work, we are interested in statistical models that can predict a piece of code given only historical changes.

Finally, there are some domain-specific approaches to perform automated code changes, *e.g.*, generating error handling code [71], [72], API related changes [9]–[14], [73], *etc.*, automatic refactorings [15]–[18], *etc.* Unlike these work, CODIT focuses on general code changes.

IX. CONCLUSION

In this work, we propose and evaluate CODIT, a tree2tree neural machine translation model for suggesting eminent changes to source code. CODIT’s objective is to suggest changes in such a way that maximizes the similarity with the change pattern observed in the wild. We evaluate our work against 6735 real-world patches. The results indicate that such tree2tree NMT models have the potential of generating code patches—more promise towards generating abstract patch templates than the concrete ones. They outperform their popular seq2seq alternatives by a large margin indicating tree-based modeling is probably a better approach to handle code change. They further show promise in repairing bug fixes. We will explore CODIT’s potential in fixing real-world bugs in the near future.

REFERENCES

[1] T. T. Nguyen, H. A. Nguyen, N. H. Pham, J. Al-Kofahi, and T. N. Nguyen, “Recurring bug fixes in object-oriented programs,” in *Proceedings of the 32nd ACM/IEEE International Conference on Software Engineering-Volume 1*, pp. 315–324, ACM, 2010.

[2] H. A. Nguyen, A. T. Nguyen, T. T. Nguyen, T. N. Nguyen, and H. Rajan, “A study of repetitiveness of code changes in software evolution,” in *Proceedings of the 28th IEEE/ACM International Conference on Automated Software Engineering*, pp. 180–190, IEEE Press, 2013.

[3] B. Ray, M. Nagappan, C. Bird, N. Nagappan, and T. Zimmermann, “The uniqueness of changes: Characteristics and applications,” *MSR ’15*, ACM, 2015.

[4] M. Martinez, W. Weimer, and M. Monperrus, “Do the fix ingredients already exist? an empirical inquiry into the redundancy assumptions of program repair approaches,” in *Companion Proceedings of the 36th International Conference on Software Engineering*, pp. 492–495, ACM, 2014.

[5] E. T. Barr, Y. Brun, P. Devanbu, M. Harman, and F. Sarro, “The plastic surgery hypothesis,” in *Proceedings of the 22nd ACM SIGSOFT International Symposium on Foundations of Software Engineering*, pp. 306–317, ACM, 2014.

[6] B. Ray, M. Kim, S. Person, and N. Rungta, “Detecting and characterizing semantic inconsistencies in ported code,” in *Automated Software Engineering (ASE), 2013 IEEE/ACM 28th International Conference on*, pp. 367–377, IEEE, 2013.

[7] Microsoft, “Visual Studio (<https://visualstudio.microsoft.com>).”

[8] E. Foundation, “Eclipse IDE (<https://www.eclipse.org>).”

[9] H. A. Nguyen, T. T. Nguyen, G. Wilson Jr, A. T. Nguyen, M. Kim, and T. N. Nguyen, “A graph-based approach to API usage adaptation,” in *ACM Sigplan Notices*, vol. 45, pp. 302–321, ACM, 2010.

[10] W. Tansey and E. Tilevich, “Annotation refactoring: inferring upgrade transformations for legacy applications,” in *ACM Sigplan Notices*, vol. 43, pp. 295–312, ACM, 2008.

[11] V. Raychev, M. Vechev, and E. Yahav, “Code completion with statistical language models,” in *Acm Sigplan Notices*, vol. 49, pp. 419–428, ACM, 2014.

[12] J. Andersen, A. C. Nguyen, D. Lo, J. L. Lawall, and S.-C. Khoo, “Semantic patch inference,” in *Automated Software Engineering (ASE), 2012 Proceedings of the 27th IEEE/ACM International Conference on*, pp. 382–385, IEEE, 2012.

[13] Y. Padiou, J. Lawall, R. R. Hansen, and G. Muller, “Documenting and automating collateral evolutions in linux device drivers,” in *Acm sigops operating systems review*, vol. 42, pp. 247–260, ACM, 2008.

[14] A. T. Nguyen, M. Hilton, M. Codoban, H. A. Nguyen, L. Mast, E. Rademacher, T. N. Nguyen, and D. Dig, “API code recommendation using statistical learning from fine-grained changes,” in *Proceedings of the 2016 24th ACM SIGSOFT International Symposium on Foundations of Software Engineering*, pp. 511–522, ACM, 2016.

[15] S. R. Foster, W. G. Griswold, and S. Lerner, “WitchDoctor: IDE support for real-time auto-completion of refactorings,” in *Software Engineering (ICSE), 2012 34th International Conference on*, pp. 222–232, IEEE, 2012.

[16] V. Raychev, M. Schäfer, M. Sridharan, and M. Vechev, “Refactoring with synthesis,” in *ACM SIGPLAN Notices*, vol. 48, pp. 339–354, ACM, 2013.

[17] X. Ge, Q. L. DuBose, and E. Murphy-Hill, “Reconciling manual and automatic refactoring,” in *Proceedings of the 34th International Conference on Software Engineering*, pp. 211–221, IEEE Press, 2012.

[18] N. Meng, L. Hua, M. Kim, and K. S. McKinley, “Does automated refactoring obviate systematic editing?,” in *Proceedings of the 37th International Conference on Software Engineering-Volume 1*, pp. 392–402, IEEE Press, 2015.

[19] N. Meng, M. Kim, and K. S. McKinley, “Systematic editing: generating program transformations from an example,” *ACM SIGPLAN Notices*, vol. 46, no. 6, pp. 329–342, 2011.

[20] R. Rolim, G. Soares, L. D’Antoni, O. Polozov, S. Gulwani, R. Gheyri, R. Suzuki, and B. Hartmann, “Learning syntactic program transformations from examples,” in *Proceedings of the 39th International Conference on Software Engineering*, pp. 404–415, IEEE Press, 2017.

[21] N. Meng, M. Kim, and K. S. McKinley, “LASE: Locating and applying systematic edits by learning from examples,” in *Proceedings of the 2013 International Conference on Software Engineering*, pp. 502–511, IEEE Press, 2013.

[22] M. Allamanis, E. T. Barr, P. Devanbu, and C. Sutton, “A survey of machine learning for big code and naturalness,” *ACM Computing Surveys (to appear)*, 2018.

[23] M. Tufano, C. Watson, G. Bavota, M. Di Penta, M. White, and D. Poshyvanyk, “An empirical investigation into learning bug-fixing patches in the wild via neural machine translation,” 2018.

[24] M. Beller, G. Gousios, and A. Zaidman, “TravisTorrent: Synthesizing Travis CI and GitHub for full-stack research on continuous integration,” in *Proceedings of the 14th working conference on mining software repositories*, 2017.

[25] A. Hindle, E. T. Barr, Z. Su, M. Gabel, and P. Devanbu, “On the naturalness of software,” in *2012 34th International Conference on Software Engineering (ICSE)*, pp. 837–847, IEEE, 2012.

[26] Z. Tu, Z. Su, and P. Devanbu, “On the localness of software,” in *SIGSOFT FSE*, pp. 269–280, 2014.

[27] V. J. Hellendoorn and P. Devanbu, “Are deep neural networks the best choice for modeling source code?,” in *Proceedings of the 2017 11th Joint Meeting on Foundations of Software Engineering*, pp. 763–773, ACM, 2017.

[28] M. R. Parvez, S. Chakraborty, B. Ray, and K.-W. Chang, “Building language models for text with named entities,” 2018.

[29] J. Mallinson, R. Sennrich, and M. Lapata, “Paraphrasing revisited with neural machine translation,” in *Proceedings of the 15th Conference of the European Chapter of the Association for Computational Linguistics: Volume 1, Long Papers*, vol. 1, pp. 881–893, 2017.

[30] D. Bahdanau, K. Cho, and Y. Bengio, “Neural machine translation by jointly learning to align and translate,” *arXiv preprint arXiv:1409.0473*, 2014.

- [31] M. Allamanis, H. Peng, and C. Sutton, "A convolutional attention network for extreme summarization of source code," in *International Conference on Machine Learning*, pp. 2091–2100, 2016.
- [32] P. Yin and G. Neubig, "A syntactic neural model for general-purpose code generation," in *Proceedings of the 55th Annual Meeting of the Association for Computational Linguistics (Volume 1: Long Papers)*, vol. 1, pp. 440–450, 2017.
- [33] C. Maddison and D. Tarlow, "Structured generative models of natural source code," in *International Conference on Machine Learning*, pp. 649–657, 2014.
- [34] A. T. Nguyen and T. N. Nguyen, "Graph-based statistical language model for code," in *Software Engineering (ICSE), 2015 IEEE/ACM 37th IEEE International Conference on*, vol. 1, pp. 858–868, IEEE, 2015.
- [35] M. Allamanis, M. Brockschmidt, and M. Khademi, "Learning to represent programs with graphs," *arXiv preprint arXiv:1711.00740*, 2017.
- [36] H. Chen, S. Huang, D. Chiang, and J. Chen, "Improved neural machine translation with a syntax-aware encoder and decoder," in *Proceedings of the 55th Annual Meeting of the Association for Computational Linguistics (Volume 1: Long Papers)*, (Vancouver, Canada), pp. 1936–1945, Association for Computational Linguistics, July 2017.
- [37] J. Chung, C. Gulcehre, K. Cho, and Y. Bengio, "Empirical evaluation of gated recurrent neural networks on sequence modeling," *arXiv preprint arXiv:1412.3555*, 2014.
- [38] A. Eriguchi, K. Hashimoto, and Y. Tsuruoka, "Tree-to-sequence attentional neural machine translation," *arXiv preprint arXiv:1603.06075*, 2016.
- [39] O. Vinyals, M. Fortunato, and N. Jaitly, "Pointer networks," in *Advances in Neural Information Processing Systems*, pp. 2692–2700, 2015.
- [40] J.-R. Falleri, F. Morandat, X. Blanc, M. Martinez, and M. Monperrus, "Fine-grained and accurate source code differencing," in *Proceedings of the 29th ACM/IEEE international conference on Automated software engineering*, pp. 313–324, ACM, 2014.
- [41] K. Papineni, S. Roukos, T. Ward, and W.-J. Zhu, "BLEU: a method for automatic evaluation of machine translation," in *Proceedings of the 40th annual meeting on association for computational linguistics*, pp. 311–318, Association for Computational Linguistics, 2002.
- [42] D. R. Reddy *et al.*, "Speech understanding systems: A summary of results of the five-year research effort," *Department of Computer Science. Carnegie-Mell University, Pittsburgh, PA*, 1977.
- [43] R. Just, D. Jalali, and M. D. Ernst, "Defects4J: A database of existing faults to enable controlled testing studies for java programs," in *Proceedings of the 2014 International Symposium on Software Testing and Analysis*, pp. 437–440, ACM, 2014.
- [44] G. Klein, Y. Kim, Y. Deng, J. Senellart, and A. M. Rush, "OpenNMT: Open-Source Toolkit for Neural Machine Translation," *ArXiv e-prints*.
- [45] M. Pawlik and N. Augsten, "Tree edit distance: Robust and memory-efficient," *Information Systems*, vol. 56, pp. 157–173, 2016.
- [46] M. Pawlik and N. Augsten, "Efficient computation of the tree edit distance," *ACM Transactions on Database Systems (TODS)*, vol. 40, no. 1, p. 3, 2015.
- [47] R. K. Saha, Y. Lyu, H. Yoshida, and M. R. Prasad, "Elixir: Effective object-oriented program repair," in *Automated Software Engineering (ASE), 2017 32nd IEEE/ACM International Conference on*, pp. 648–659, IEEE, 2017.
- [48] D. Kim, J. Nam, J. Song, and S. Kim, "Automatic patch generation learned from human-written patches," in *Proceedings of the 2013 International Conference on Software Engineering*, pp. 802–811, IEEE Press, 2013.
- [49] E. Reiter, "A structured review of the validity of BLEU," *Computational Linguistics*, no. Just Accepted, pp. 1–12, 2018.
- [50] B. Ray, V. Hellendoorn, S. Godhane, Z. Tu, A. Bacchelli, and P. Devanbu, "On the naturalness of buggy code," in *Proceedings of the 38th International Conference on Software Engineering*, pp. 428–439, ACM, 2016.
- [51] S. Wang, D. Chollak, D. Movshovitz-Attias, and L. Tan, "Bugram: bug detection with n-gram language models," in *Proceedings of the 31st IEEE/ACM International Conference on Automated Software Engineering*, pp. 708–719, ACM, 2016.
- [52] M. White, M. Tufano, C. Vendome, and D. Poshyanyk, "Deep learning code fragments for code clone detection," in *Proceedings of the 31st IEEE/ACM International Conference on Automated Software Engineering*, pp. 87–98, ACM, 2016.
- [53] X. Gu, H. Zhang, and S. Kim, "Deep code search," in *Proceedings of the 40th International Conference on Software Engineering*, pp. 933–944, ACM, 2018.
- [54] S. Karaivanov, V. Raychev, and M. Vechev, "Phrase-based statistical translation of programming languages," in *Proceedings of the 2014 ACM International Symposium on New Ideas, New Paradigms, and Reflections on Programming & Software*, pp. 173–184, ACM, 2014.
- [55] A. T. Nguyen, T. T. Nguyen, and T. N. Nguyen, "Divide-and-conquer approach for multi-phase statistical migration for source code," in *Automated Software Engineering (ASE), 2015 30th IEEE/ACM International Conference on*, pp. 585–596, IEEE, 2015.
- [56] A. T. Nguyen, H. A. Nguyen, T. T. Nguyen, and T. N. Nguyen, "Statistical learning approach for mining API usage mappings for code migration," in *Proceedings of the 29th ACM/IEEE international conference on Automated software engineering*, pp. 457–468, ACM, 2014.
- [57] X. Chen, C. Liu, and D. Song, "Tree-to-tree neural networks for program translation," *arXiv preprint arXiv:1802.03691*, 2018.
- [58] R. Gupta, S. Pal, A. Kanade, and S. Shevade, "DeepFix: Fixing common C language errors by deep learning," in *AAAI*, pp. 1345–1351, 2017.
- [59] S. Kaleeswaran, V. Tulsian, A. Kanade, and A. Orso, "Minthint: Automated synthesis of repair hints," in *Proceedings of the 36th International Conference on Software Engineering*, pp. 266–276, ACM, 2014.
- [60] C. Le Goues, M. Dewey-Vogt, S. Forrest, and W. Weimer, "A systematic study of automated program repair: Fixing 55 out of 105 bugs for \$8 each," in *Software Engineering (ICSE), 2012 34th International Conference on*, pp. 3–13, IEEE, 2012.
- [61] P. Liu, O. Tripp, and X. Zhang, "Flint: fixing linearizability violations," in *ACM SIGPLAN Notices*, vol. 49, pp. 543–560, ACM, 2014.
- [62] F. Logozzo and T. Ball, "Modular and verified automatic program repair," in *ACM SIGPLAN Notices*, vol. 47, pp. 133–146, ACM, 2012.
- [63] C. Le Goues, T. Nguyen, S. Forrest, and W. Weimer, "Genprog: A generic method for automatic software repair," *Ieee transactions on software engineering*, vol. 38, no. 1, p. 54, 2012.
- [64] F. Long and M. Rinard, "Staged program repair with condition synthesis," in *Proceedings of the 2015 10th Joint Meeting on Foundations of Software Engineering*, pp. 166–178, ACM, 2015.
- [65] H. D. T. Nguyen, D. Qi, A. Roychoudhury, and S. Chandra, "Semfix: Program repair via semantic analysis," in *Software Engineering (ICSE), 2013 35th International Conference on*, pp. 772–781, IEEE, 2013.
- [66] S. Mechtaev, J. Yi, and A. Roychoudhury, "Angelix: Scalable multiline program patch synthesis via symbolic analysis," in *Proceedings of the 38th international conference on software engineering*, pp. 691–701, ACM, 2016.
- [67] A. Arcuri and X. Yao, "A novel co-evolutionary approach to automatic software bug fixing," in *Evolutionary Computation, 2008. CEC 2008.(IEEE World Congress on Computational Intelligence). IEEE Congress on*, pp. 162–168, IEEE, 2008.
- [68] X.-B. D. Le, D. Lo, and C. Le Goues, "History driven automated program repair," 2016.
- [69] M. Boshernitsan, S. L. Graham, and M. A. Hearst, "Aligning development tools with the way programmers think about code changes," in *Proceedings of the SIGCHI conference on Human factors in computing systems*, pp. 567–576, ACM, 2007.
- [70] R. Robbes and M. Lanza, "Example-based program transformation," in *International Conference on Model Driven Engineering Languages and Systems*, pp. 174–188, Springer, 2008.
- [71] Y. Tian and B. Ray, "Automatically diagnosing and repairing error handling bugs in c," in *Proceedings of the 2017 11th Joint Meeting on Foundations of Software Engineering*, pp. 752–762, ACM, 2017.
- [72] B. Hartmann, D. MacDougall, J. Brandt, and S. R. Klemmer, "What would other programmers do: suggesting solutions to error messages," in *Proceedings of the SIGCHI Conference on Human Factors in Computing Systems*, pp. 1019–1028, ACM, 2010.
- [73] V. Murali, L. Qi, S. Chaudhuri, and C. Jermaine, "Neural sketch learning for conditional program generation," *arXiv preprint arXiv:1703.05698*, 2017.