

Real-time Data Flow Control for CBM-TOF Super Module Quality Evaluation

Wei. Jiang, Xiru Huang, Ping Cao, Chao Li, Junru Wang, Jiawen Li, Jianhui Yuan, Qi An

Abstract—Super module assembled with MRPC detectors is the component unit of TOF (Time of Flight) system for the Compressed Baryonic Matter (CBM) experiment. Quality of super modules needs to be evaluated before it is applied in CBM-TOF. Time signals exported from super module are digitalized at TDC (Time to Digital Converter) station. Data rate is up to 6 Gbps at each TDC station, which brings a tremendous pressure for data transmission in real time. In this paper, a real-time data flow control method is designed. In this control method, data flow is divided into 3 types: scientific data flow, status data flow and control data flow. In scientific data flow, data of each TDC station is divided into 4 sub-flows, and then is read out by a parallel and hierarchical network, which consists of multiple readout mother boards and daughter boards groups. In status data flow, status data is aggregated into a specific readout mother board. Then it is uploaded to DAQ via readout daughter board. In control data flow, control data is downloaded to all circuit modules in the opposite direction of status data flow. Preliminary test result indicated data of STS was correctly transmitted to DAQ with no error and three type data flows were control orderly in real time. This data flow control method can meet the quality evaluation requirement of super module in CBM-TOF.

Index Terms—DAQ, data flow, readout electronics, real-time.

I. INTRODUCTION

COMPRESSED Baryonic Matter (CBM) experiment aims at the phase diagram of strongly interacting matter [1] [2]. TOF (Time of Flight) system is one of the key parts for hadron identification. Super module assembled with MRPC detectors is the component unit of CBM-TOF system. The event rate of single-channel is up to 100-300 kHz in each super module, which requires a high performance of super modules [3] [4]. Before these super modules are applied in CBM-TOF, a corresponding electronics system is needed to evaluate the quality of super modules.

In the electronics system, time signals exported from super modules are digitalized at TDC (Time to Digital Converter) modules [5]. Then the scientific data with time information is transmitted to DAQ (data acquisition) for analysis and evaluation.

Because of the high density of detector channels and high

event rate of single channel, the real time data aggregated at front end electronics is up to 6 Gbps for each super module [5]. The huge quantities of data brings a tremendous pressure for data transmission between front end electronics and DAQ. All of the data must be transmitted to DAQ orderly without any loss or jam in real time.

In a word, the real time control of data flow is the key requirement of quality evaluation electronics of super module.

II. ANALYSIS OF DATA FLOW

To analyze the data flow in the electronics system clearly, a model of data flow is built, which is shown in Fig 1. This model consists of three parts: FEEs (front end electronics), readout system, and DAQ. Each FEE is corresponding to one super module. Time signals exported from super module are digitalized at FEEs. Data with time information is called scientific data. The maximum data rate at each FEE is up to 6 Gbps. DAQ has 3 components: status monitor, data analyzer and control system [6]. Readout system is responsible for all the communication between FEEs and DAQ.

Data flow in this model is divided into three types: scientific data flow, status data flow and control data flow.

In status data flow, status data of all circuit modules is aggregated and is uploaded to DAQ. Thus the DAQ knows whether every part of electronics works well in real time.

In control data flow, control commands are downloaded to specific circuit modules from DAQ. Therefore the behavior of specified module can be control according to current status in real time.

In scientific data flow, all of the scientific data of FEEs needs to be transmitted to DAQ in real time. The maximum rate of each FEE is up to 6 Gbps, so the readout system confronts a tremendous transmission pressure. Moreover, the readout system is required for good flexibility and expansibility so that the readout system still works well when FEEs number increases.

In a word, the readout system is the bottleneck in data transmission, which needs to be considered carefully. Based on the analysis above, a parallel network is necessary to share the transmission pressure of readout system. To get good expansibility, Gigabit Ethernet is adopted as the standard

Manuscript received June 23, 2018.

This work was supported by the National Basic Research Program (973 Program) of China under Grant 2015CB856906.

The authors are with the State Key Laboratory of Particle Detection and Electronics, University of Science and Technology of China, Hefei 230026, China (email: xiru@ustc.edu.cn).

W. Jiang, P. Cao, J. Li and J. Yuan are with the Department of Engineering and Applied Physics, University of Science and Technology of China, Hefei 230026, China.

X. Huang, C. Li, J. Wang and Q. An are with the Department of Modern Physics, University of Science and Technology of China, Hefei 230026, China.

interface with PC. In addition, an Ethernet switch is used to simplify the connection with PC.

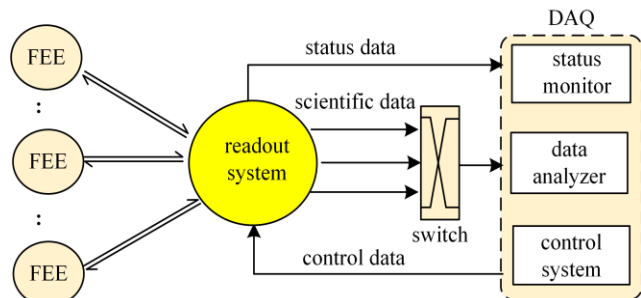

Fig. 1. Model of data flow

III. CONTROL SCHEMA OF DATA FLOW

According to the model proposed above, the concrete control scheme of data flow is shown in Fig 2. As is analyzed above, the bottleneck of data flow is the readout system. To share the transmission pressure, the control method of data flow is designed as a hierarchical and parallel structure based on Gigabit Ethernet.

A. Overall Structure of Control Method

The main body of readout system are DMB (DRM Mother Board) and DRM (Data Readout Module) groups. DRM is used to exchange data with Gigabit Ethernet. Data in FPGA customized protocol is converted into Ethernet format data at the DRM. The DMB is the mother board of DRM, with 2 DRMs on each DMB. This design improves the compactness of electronics and simplifies the electronics structure. STS (Sandwich TDC Station) is the corresponding FEE in this study. One STS is corresponding to one super module. Thus the data aggregated at each STS is 6 Gbps [5].

Preliminary test indicated that the maximum transmission capacity of one DRM is 550 Mbps. In the control schema of data flow, 16 DRMs are adopted to read out one STS data. And one DRM is expected to read out data at a speed of 400 Mbps. According to the topological structure in Fig 2, 4 master-slave DMB groups are needed for transmission. Data of STS is transmitted to 4 master DMBs via 4 optical fibers at 1.5 Gbps per link. The optical transmission cuts off the electronic connection between STS and DMBs, and makes long distance transmission available. Slave DMB shares half of the transmission pressure of its master DMB.

B. Control Process of Data Flow

In accordance with the schema in Fig 2, the control process of data flow is described as follows. Firstly scientific data and status data of STS are mixed at STS and are transmitted to 4 master DMBs via same optical links. This design is to simplify the connection between STS and DMBs. Then by logic configuration, scientific data and status data of STS is separated at master DMBs and is uploaded in independent physics links thereafter.

Each DMB, master or slave, has 2 DRMs on it. After first stage equipartition between master DMB and slave DMB and second equipartition between 2 DRMs, scientific data is equally distributed to 16 DRMs. Each DRM is expected to support

Gigabit Ethernet transmission to DAQ at the rate of 400 Mbps.

After separated with scientific data, status data is aggregated into a specific DMB via crate backplane, and then is uploaded to DAQ. As for control data, it is firstly downloaded from DAQ to the specific DMB. Then it is fan out to other DMBs via crate backplane and is also sent to STS via optical fiber.

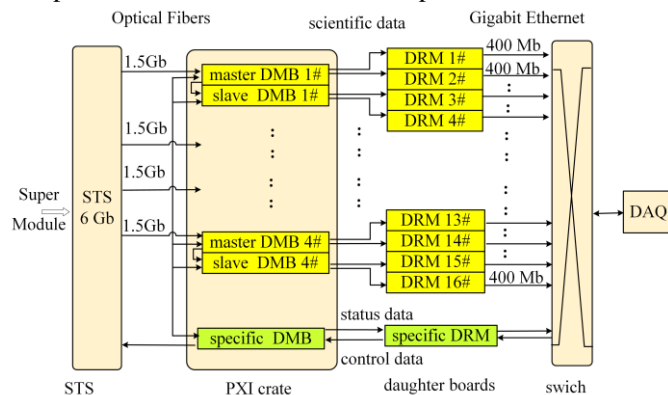

Fig. 2. Control schema of data flow

IV. HARDWARE DESIGN OF DMB AND DRM

DMB and DRM are the hardware support for control schema. The design structure of DMB and DRM is shown in Fig 3, and corresponding photo is shown in Fig 4.

A. Hardware Design of DMB

DMB is designed as a mother board with 2 DRMs on it. PMC connector is adopted as the physics interface.

There are 4 Gigabit transceiver blocks (GXBs) integrated in FPGA [7]. The GXB can support high speed and reliable series data transmission at a maximum data rate of 2 Gbps. As is shown in Fig 3, one GXB of master DMB is used for receiving data from STS. Another GXB is used to distribute half of the data to slave DMB. The last 2 GXBs are used to transmit data to 2 DRMs.

J2 connector is used for communication among DMBs and PXI crate backplane. As is shown in Fig 2, the specific DMB gathers status data and fans out control data via crate backplane. SFP is used for photoelectric conversion between STS and DMBs. A pair of differential LEMO connectors is adopted as the physics connector between master DMB and slave DMB. LEMO connectors are exceptionally reliable and robust owing to the "Push-Pull" self-latching system [8].

B. Hardware Design of DRM

DRM is designed to support Gigabit Ethernet transmission. Data in FPGA customized protocol is converted into Ethernet format data at the DRM. DRM mainly consists of SoC FPGA chip, DDR3 RAM and Ethernet module. It is implemented on the basis of SoC FPGA technology which package FPGA and ARM processor in a single die [9]. Embedded Linux software, which runs on hard processor system, can exchange data with PC via Gigabit Ethernet.

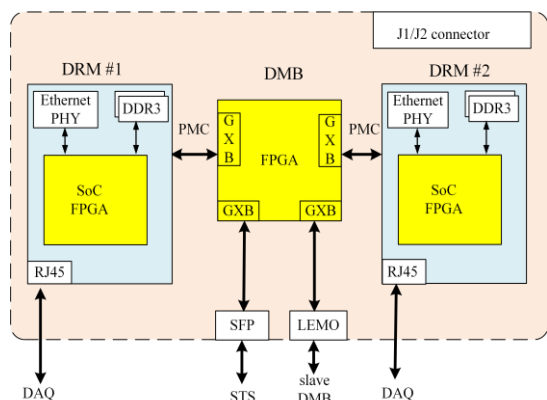

Fig. 3. Structure of DMB and DRM

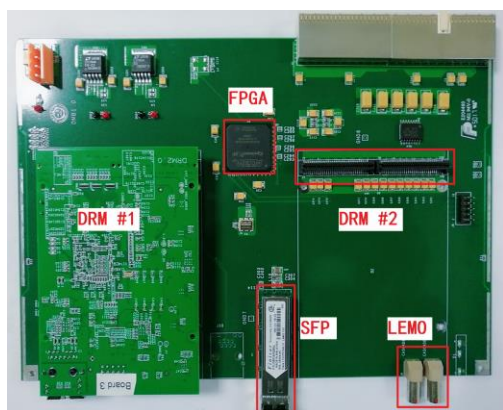

Fig. 4. Photo of DMB and DRM

V. PRELIMINARY TESTS

A. System test

To verify the performance of the data flow control method of this paper, a system level test was done. The test plan is shown in Fig 7. As is expounded in part III, data of STS is divided into 4 sub-flows and is transmitted via 4 optical fibers. Because the parallel readout method for 4 sub-flows is the same, the test system can be simplified with only one sub-flow. The expected transmission rate of the test system is 1.5 Gbps. In this test, data was generated at a rate of 1.6 Gbps at STS, which was a little higher than the expected rate for necessary margin.

Fig 8 is the photo of test site in lab. Test result showed that 1.6 Gbps data was correctly transmitted to DAQ with no error, and control data was correctly downloaded to all circuit modules. In addition, status data indicated that all circuit modules ran well during the test.

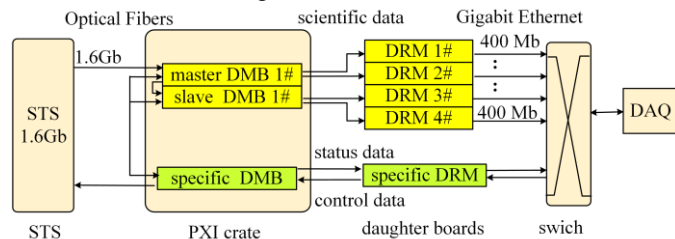

Fig. 7. System test plan



Fig. 8. Photo of test site in lab

VI. CONCLUSION

In this paper, a real-time data flow control method is designed for quality evaluation of super module in CBM-TOF. Data flow is divided into three types: scientific data, status data flow and control data flow. The data rate of one STS is up to 6 Gbps. To share the transmission pressure, a parallel and hierarchical structure is designed, which consists of parallel DMB and DRM groups. Status data and control data are transmitted on independent physics link and in opposite direction with each other. This control method has a good flexibility and expansibility when the number of super module increases. Preliminary test result indicates data of STS was correctly transmitted to DAQ with no error and three type data flows were control orderly in real time. In a word, this data flow control method can meet the quality evaluation requirement of super module in CBM-TOF.

REFERENCES

- [1] P. Senger, "The compressed baryonic matter experiment," *J. Phys. G: Nucl. Part. Phys.*, vol. 28, no. 7, pp. 1869-1875, 2002.
- [2] J. M. Heuser. (2015, May). Status of the CBM experiment. Presented at 3rd International Conference on New Frontiers in Physics. [Online]. Available: <http://dx.doi.org/10.1051/epjconf/20159501006>.
- [3] I. Deppner, et al, "The CBM time-of-flight wall," *Nuclear Instruments and Methods in Physics Research Section A: Accelerators, Spectrometers, Detectors and Associated Equipment*, vol. 661, pp. 121-124, Jan. 2012.
- [4] CBM collaboration, "Technical Design Report for the CBM Time-of-flight System (TOF)", GSI Darmstadt, Oct, 2014. [Online]. Available: http://repository.gsi.de/record/109024/files/tof-tdr-final_rev6036.pdf
- [5] J. Zheng et al., "Low-cost FPGA TDC with High Resolution and Density," *IEEE Trans. Nucl. Sci.*, vol. 64, no. 6, pp. 1401-1408, Jun. 2017.
- [6] H.G. Essel, "Future DAQ for CBM: On-line Event Selection," *IEEE Trans. Nucl. Sci.*, vol. 53, no. 3, pp. 677-681, Jun. 2006.
- [7] *Cyclone IV Device Handbook, Volume 2*, 3.7ed., Altera Co., San Jose, CA, USA, 2015.
- [8] LEMO. "00 NIM-CAMAC & 01 COAXIAL CONNECTORS". [Online]. Available: http://www.mouser.cn/datasheet/2/232/00and01Coaxial_en-1108356.pdf
- [9] *Cyclone V Device Handbook*, Intel Co., San Jose, CA, USA, 2015.