

Structural Rounding: Approximation Algorithms for Graphs Near an Algorithmically Tractable Class

Erik D. Demaine¹, Timothy D. Goodrich², Kyle Kloster², Brian Lavallee²,
Quanquan C. Liu¹, Blair D. Sullivan², Ali Vakilian¹, and Andrew van der Poel²

¹MIT, Cambridge, MA, USA, {edemaine,quanquan,vakilian}@mit.edu

²NC State University, Raleigh, NC, USA,

{tdgoodri,kakloste,blavall,blair_sullivan,ajvande4}@ncsu.edu

Abstract

We develop a new framework for generalizing approximation algorithms from the structural graph algorithm literature so that they apply to graphs somewhat close to that class (a scenario we expect is common when working with real-world networks) while still guaranteeing approximation ratios. The idea is to *edit* a given graph via vertex- or edge-deletions to put the graph into an algorithmically tractable class, apply known approximation algorithms for that class, and then *lift* the solution to apply to the original graph. We give a general characterization of when an optimization problem is amenable to this approach, and show that it includes many well-studied graph problems, such as INDEPENDENT SET, VERTEX COVER, FEEDBACK VERTEX SET, MINIMUM MAXIMAL MATCHING, CHROMATIC NUMBER, (ℓ -)DOMINATING SET, EDGE (ℓ -)DOMINATING SET, and CONNECTED DOMINATING SET.

To enable this framework, we develop new editing algorithms that find the approximately-fewest edits required to bring a given graph into one of a few important graph classes (in some cases also approximating the target parameter of the family). For bounded degeneracy, we obtain a bicriteria $(4, 4)$ -approximation which also extends to a smoother bicriteria trade-off. For bounded treewidth, we obtain a bicriteria $(O(\log^{1.5} n), O(\sqrt{\log w}))$ -approximation, and for bounded pathwidth, we obtain a bicriteria $(O(\log^{1.5} n), O(\sqrt{\log w} \cdot \log n))$ -approximation. For treedepth 2 (related to bounded expansion), we obtain a 4-approximation. We also prove complementary hardness-of-approximation results assuming $P \neq NP$: in particular, these problems are all log-factor inapproximable, except the last which is not approximable below some constant factor (2 assuming UGC).

Keywords: structural rounding, graph editing, maximum subgraph problem, treewidth, degeneracy, APX-hardness, approximation algorithms

Contents

1	Introduction	1
2	Techniques	5
3	Preliminaries	7
4	Structural Rounding	13
4.1	General Framework	13

4.2	Vertex Deletions	15
4.3	Edge Deletions	18
4.4	Vertex Deletion for Annotated Problems (Vertex* Deletion)	20
5	Editing Algorithms	23
5.1	Degeneracy: Density-Based Bicriteria Approximation	23
5.1.1	Analysis overview and the local ratio theorem	24
5.1.2	$\left(\frac{4m-\beta rn}{m-rn}, \beta\right)$ -approximation for vertex deletion	25
5.2	Degeneracy: LP-based Bicriteria Approximation	27
5.2.1	$(6, 6)$ -approximation for vertex deletion	27
5.3	$(5, 5)$ -approximation for edge deletion	29
5.3.1	Integrality gap of DEGENEDGEEDIT-LP and DEGENVERTEXEDIT-LP	31
5.4	Degeneracy: $O(\log n)$ Greedy Approximation	32
5.5	Treewidth/Pathwidth: Bicriteria Approximation for Vertex Editing	35
5.5.1	Treewidth: $(O(\log^{1.5} n), O(\sqrt{\log w}))$ -approximation for vertex deletion	36
5.5.2	Pathwidth: $(O(\log^{1.5} n), O(\sqrt{\log w} \cdot \log n))$ -approximation for vertex deletion	37
5.6	Bounded Degree: Polynomial Time Algorithm for Edge Editing	39
5.7	Treewidth 2: $O(1)$ -approximation for Editing	40
6	Editing Hardness Results	40
6.1	Degeneracy: $o(\log(n/r))$ -Inapproximability of Vertex and Edge Editing	40
6.2	Weak Coloring Numbers: $o(t)$ -Inapproximability of Editing	46
6.3	Treewidth and Clique Number: $o(\log n)$ -Inapproximability of Vertex Editing	54
6.4	Bounded Degree: $(\ln d - C \cdot \ln \ln d)$ -Inapproximability of Vertex Editing	58
6.5	Treewidth 2: $(2 - \varepsilon)$ -Inapproximability of Vertex Editing	60
6.6	Treewidth 2: APX-hardness of Edge Editing	62
7	Open Problems	64

1 Introduction

Network science has empirically established that real-world networks (social, biological, computer, etc.) exhibit significant sparse structure. Theoretical computer science has shown that graphs with certain structural properties enable significantly better approximation algorithms for hard problems. Unfortunately, the experimentally observed structures and the theoretically required structures are generally not the same: mathematical graph classes are rigidly defined, while real-world data is noisy and full of exceptions. This paper provides a framework for extending approximation guarantees from existing rigid classes to broader, more flexible graph families that are more likely to include real-world networks.

Specifically, we hypothesize that most real-world networks are in fact *small perturbations of graphs from a structural class*. Intuitively, these perturbations may be exceptions caused by unusual/atypical behavior (e.g., weak links rarely expressing themselves), natural variation from an underlying model, or noise caused by measurement error or uncertainty. Formally, a graph is γ -close to a structural class \mathcal{C} , where $\gamma \in \mathbb{N}$, if some γ edits (e.g., vertex deletions, edge deletions, or edge contractions) bring the graph into class \mathcal{C} .

Our goal is to extend existing approximation algorithms for a structural class \mathcal{C} to apply more broadly to graphs γ -close to \mathcal{C} . To achieve this goal, we need two algorithmic ingredients:

1. **Editing algorithms.** Given a graph G that is γ -close to a structural class \mathcal{C} , find a sequence of $f(\gamma)$ edits that edit G into \mathcal{C} . When the structural class is parameterized (e.g., treewidth $\leq w$), we may also approximate those parameters.
2. **Structural rounding algorithms.** Develop approximation algorithms for optimization problems on graphs γ -close to a structural class \mathcal{C} by converting ρ -approximate solutions on an edited graph in class \mathcal{C} into $g(\rho, \gamma)$ -approximate solutions on the original graph.

1.1 Our Results: Structural Rounding

In Section 4, we present a general metatheorem giving sufficient conditions for an optimization problem to be amenable to the structural rounding framework. Specifically, if a problem Π has an approximation algorithm in structural class \mathcal{C} , the problem and its solutions are “stable” under an

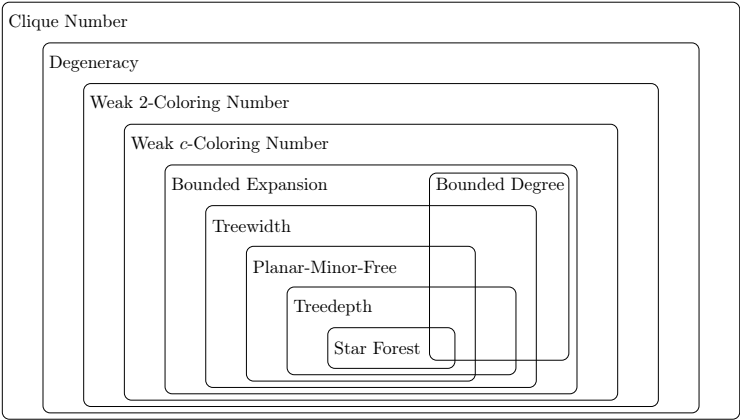

Figure 1: Illustration of hierarchy of structural graph classes used in this paper.

edit operation, and there is an α -approximate algorithm for editing to \mathcal{C} , then we get an approximation algorithm for solving Π on graphs γ -close to \mathcal{C} . The new approximation algorithm incurs an additive error of $O(\gamma)$, so we preserve PTAS-like $(1+\varepsilon)$ approximation factors provided $\gamma \leq \delta \text{OPT}_\Pi$ for a suitable constant $\delta = \delta(\varepsilon, \alpha) > 0$.

For example, we obtain $(1+O(\delta \log^{1.5} n))$ -approximation algorithms for VERTEX COVER, FEEDBACK VERTEX SET, MINIMUM MAXIMAL MATCHING, and CHROMATIC NUMBER on graphs $(\delta \cdot \text{OPT}_\Pi(G))$ -close to having treewidth w via vertex deletions (generalizing exact algorithms for bounded treewidth graphs); and we obtain a $(1-4\delta)/(4r+1)$ -approximation algorithm for INDEPENDENT SET on graphs $(\delta \cdot \text{OPT}_\Pi(G))$ -close to having degeneracy r (generalizing a $1/r$ -approximation for degeneracy- r graphs). These results use our new algorithms for editing to treewidth- w and degeneracy- r graph classes as summarized next.

1.2 Our Results: Editing

We develop editing approximation algorithms and/or hardness-of-approximation results for six well-studied graph classes: bounded clique number, bounded degeneracy, bounded treewidth and pathwidth, bounded treedepth, bounded weak c -coloring number, and bounded degree. Figure 1 summarizes the relationships among these classes, and Table 1 summarizes our results for each class.

Graph Family \mathcal{C}_λ	Edit Operation ψ	
	Vertex Deletion	Edge Deletion
Bounded Degree (d)	d-BDD-V $O(\log d)$ -approx. [29] $(\ln d - C \cdot \ln \ln d)$ -inapprox.	d-BDD-E Polynomial time [46]
Bounded Degeneracy (r)	r-DE-V $O(r \log n)$ -approx. $(\frac{4m-\beta rn}{m-rn}, \beta)$ -approx. $(\frac{1}{\varepsilon}, \frac{4}{1-2\varepsilon})$ -approx. ($\varepsilon < 1/2$) $o(\log(n/r))$ -inapprox.	r-DE-E $O(r \log n)$ -approx. – $(\frac{1}{\varepsilon}, \frac{4}{1-\varepsilon})$ -approx. ($\varepsilon < 1$) $o(\log(n/r))$ -inapprox.
Bounded Weak c -Coloring Number (t)	t-BWE-V-c – $o(t)$ -inapprox. for $t \in o(\log n)$	t-BWE-E-c – $o(t)$ -inapprox. for $t \in o(\log n)$
Bounded Treewidth (w)	w-TW-V $(O(\log^{1.5} n), O(\sqrt{\log w}))$ -approx. $o(\log n)$ -inapprox. for $w \in \Omega(n^{1/2})$	w-TW-E $(O(\log n \log \log n), O(\log w))$ -approx. [3] –
Bounded Pathwidth (w)	w-PW-V $(O(\log^{1.5} n), O(\sqrt{\log w} \cdot \log n))$ -approx. –	w-PW-E $(O(\log n \log \log n), O(\log w \cdot \log n))$ -approx. [3] –
Star Forest	SF-V 4-approx. $(2 - \varepsilon)$ -inapprox. (UGC)	SF-E 3-approx. APX-complete

Table 1: Summary of results for $(\mathcal{C}_\lambda, \psi)$ -EDIT problems (including abbreviations and standard parameter notation). “Approx.” denotes a polynomial-time approximation or bicriteria approximation algorithm; “inapprox.” denotes inapproximability assuming $P \neq NP$ unless otherwise specified.

Hardness results. We begin by showing that vertex- and edge-deletion to degeneracy r (r -DE) are both $o(\log(n/r))$ -inapproximable. Furthermore, we prove that d -BOUNDED-DEGREE DELETION is $(\ln d - C \cdot \ln \ln d)$ -inapproximable for a constant $C > 0$; coupled with the $O(\log d)$ -approximation in [29], this establishes that $(\log d)$ is nearly tight. Additionally, we show that editing a graph to have a specified weak c -coloring number (a generalization of degeneracy) is $o(t)$ -inapproximable. The problems of vertex editing to treewidth w and clique number b are each shown to be $o(\log n)$ -inapproximable when the target parameter is $\Omega(n^\delta)$ for a constant $\delta \geq 1/2$. Each of these results are proven using a strict reduction from SET COVER.

Note that since computing treewidth (similarly, clique number and weak c -coloring number) is NP-hard, trivially it is not possible to find any polynomial time algorithm for the problem of editing to treewidth w with finite approximation guarantee. In particular, this implies that we cannot hope for anything better than bicriteria approximation algorithms in these problems. Moreover, our hardness results for these problems show that even if the optimal edit set is guaranteed to be large, i.e., polynomial in the size of the input graph, n , we cannot achieve an approximation factor better than $\Omega(\log n)$.

Finally, star forest (treedepth 2) is shown to be $(2 - \varepsilon)$ -inapproximable for vertex editing, via an L-reduction from VERTEX COVER assuming the Unique Games Conjecture, and APX-complete for edge editing, via an L-reduction from MINIMUM DOMINATING SET- B .

Positive results. Complementing our hardness result for r -DE, we present two bicriteria approximation algorithms for r -DE-V, one using the local ratio theorem and another using LP-rounding. While both approximations can be tuned with error values, they yield constant $(4, 4)$ - and $(6, 6)$ -approximations for vertex editing, respectively. Note that the LP-rounding algorithm also gives a $(5, 5)$ -approximation for r -DE-E. Using vertex separators, we show a $(O(\log^{1.5} n), O(\sqrt{\log w}))$ -bicriteria approximation for vertex editing to bounded treewidth and pathwidth. Finally, using a hitting-set approach to delete forbidden subgraphs, we show 4- and 3-approximations for the vertex and edge deletion variants of editing to star forests.

1.3 Related Work

Editing to approximate optimization problems. While there is extensive work on editing graphs into a desired graph class (summarized below), there is little prior work on how editing affects the quality of approximation algorithms (when applied to the edited graph, but we desire a solution to the original graph). The most closely related results of this type are *parameterized approximation* results, meaning that they run in polynomial time only when the number of edits is very small (constant or logarithmic input size). This research direction was initiated by Cai [10]; see the survey and results of Marx [67, Section 3.2] and e.g. [40, 66]. An example of one such result is a $\frac{7}{3}$ -approximation algorithm to Chromatic Number in graphs that become planar after γ vertex edits, with a running time of $f(\gamma) \cdot O(n^2)$, where $f(\gamma)$ is at least $2^{2^{2^{\Omega(\gamma)}}}$ (from the use of Courcelle’s Theorem), limiting its polynomial-time use to when the number of edits satisfies $\gamma = O(\lg \lg \lg n)$. In contrast, our algorithms allow up to δOPT_Π edits.

Another body of related work is the “noisy setting” introduced by Magen and Moharrami [65], which imagines that the “true” graph lies in the structural graph class that we want, and any extra edges observed in the given graph are “noise” and thus can be ignored when solving the optimization problem. This approach effectively avoids analyzing the effect of the edge edits on the approximation factor, by asking for a solution to the edited graph instead of the given graph. In this simpler model, Magen and Moharrami [65] developed a PTAS for estimating the size of INDEPENDENT SET (IS)

in graphs that are δn edits away from a minor-closed graph family (for sufficiently small values of δ). Later, Chan and Har-Peled [11] developed a PTAS that returns a $(1 + \varepsilon)$ -approximation to IS in noisy planar graphs. Recently, Bansal et al. [3] developed an LP-based approach for noisy minor-closed IS whose runtime and approximation factor achieve better dependence on δ . Moreover, they provide a similar guarantee for noisy Max k -CSPs. Unlike our work, none of these algorithms bound the approximation ratio for a solution on the original graph.

Editing algorithms. Editing graphs into a desired graph class is an active field of research and has various applications outside of graph theory, including computer vision and pattern matching [37]. In general, the editing problem is to delete a minimum set X of vertices (or edges) in an input graph G such that the result $G[V \setminus X]$ has a specific property. Previous work studied this problem from the perspective of identifying the maximum induced subgraph of G that satisfies a desired “nontrivial, hereditary” property [57, 60, 61, 86]. A graph property π is nontrivial if and only if infinitely many graphs satisfy π and infinitely many do not, and π is hereditary if G satisfying π implies that every induced subgraph of G satisfies π . The vertex-deletion problem for any nontrivial, hereditary property has been shown to be NP-complete [61] and even requires exponential time to solve, assuming the ETH [55]. Approximation algorithms for such problems have also been studied somewhat [35, 63, 77] in this domain, but in general this problem requires additional restrictions on the input graph and/or output graph properties in order to develop fast algorithms [19, 26, 27, 47, 56, 69, 70, 85].

Much past work on editing is on parameterized algorithms. For example, Dabrowski et al. [19] found that editing a graph to have a given degree sequence is W[1]-complete, but if one additionally requires that the final graph be planar, the problem becomes Fixed Parameter Tractable (FPT). Mathieson [69] showed that editing to degeneracy d is W[P]-hard (even if the original graph has degeneracy $d + 1$ or maximum degree $2d + 1$), but suggests that classes which offer a balance between the overly rigid restrictions of bounded degree and the overly global condition of bounded degeneracy (e.g., structurally sparse classes such as H -minor-free and bounded expansion [76]) may still be FPT. Some positive results on the parameterized complexity of editing to classes can be found in Drange’s 2015 PhD thesis [26]; in particular, the results mentioned include parameterized algorithms for a variety of NP-complete editing problems such as editing to threshold and chain graphs [27], star forests [27], multipartite cluster graphs [33], and \mathcal{H} -free graphs given finite \mathcal{H} and bounded indegree [28].

Our approach differs from this prior work in that we focus on approximations of edit distance that are *polynomial-time approximation algorithms*. There are previous results about approximate edit distance by Fomin et al. [34] and, in a very recent result regarding approximate edit distance to bounded treewidth graphs, by Gupta et al. [41]. Fomin et al. [34] provided two types of algorithms for vertex editing to planar \mathcal{F} -minor-free graphs: a randomized algorithm that runs in $O(f(\mathcal{F}) \cdot mn)$ time with an approximation constant $c_{\mathcal{F}}$ that depends on \mathcal{F} , as well as a fixed-parameter algorithm parameterized by the size of the edit set whose running time thus has an exponential dependence on the size of this edit set.

Gupta et al. [41] strengthen the results in [34] but only in the context of *parameterized approximation algorithms*. Namely, they give a deterministic fixed-parameter algorithm for PLANAR \mathcal{F} -DELETION that runs in $f(\mathcal{F}) \cdot n \log n + n^{O(1)}$ time and an $O(\log k)$ -approximation where k is the maximum number of vertices in any planar graph in \mathcal{F} ; this implies a fixed-parameter $O(\log w)$ -approximation algorithm with running time $2^{O(w^2 \log w)} \cdot n \log n + n^{O(1)}$ for w -TW-V and w -PW-V. They also show that w -TW-E and w -PW-E have parameterized algorithms that give an absolute constant factor approximation but with running times parameterized by w and the

maximum degree of the graph [41]. Finally, they show that when \mathcal{F} is the set of all connected graphs with three vertices, deleting the minimum number of edges to exclude \mathcal{F} as a subgraph, minor, or immersion is APX-hard for bounded degree graphs [41]. Again, these running times are weaker than our results, which give bicriteria approximation algorithms that are polynomial without any parameterization on the treewidth or pathwidth of the target graphs.

In a similar regime, Bansal et al. [3] studied w -TW-E (which implies an algorithm for w -PW-E) and designed an LP-based bicriteria approximation for this problem. For a slightly different set of problems in which the goal is to exclude a single graph H of size k as a subgraph (H -VERTEX-DELETION), there exists a simple k -approximation algorithm. On the hardness side, Guruswami and Lee [42] proved that whenever H is 2-vertex-connected, it is NP-hard to approximate H -VERTEX-DELETION within a factor of $(|V(H)| - 1 - \varepsilon)$ for any $\varepsilon > 0$ ($|V(H)| - \varepsilon$ assuming UGC). Moreover, when H is a star or simple path with k vertices, $O(\log k)$ -approximation algorithms with running time $2^{O(k^3 \log k)} \cdot n^{O(1)}$ are known [42, 58].

An important special case of the problem of editing graphs into a desired class is the *minimum planarization* problem, in which the target class is planar graphs, and the related application is approximating the well-known *crossing number* problem [17]. Refer to [6, 13, 16, 48, 51, 50, 68, 83] for the recent developments on minimum planarization and crossing number.

2 Techniques

This section summarizes the main techniques, ideas, and contributions in the rest of the paper.

2.1 Structural Rounding Framework

The main contribution of our structural rounding framework (Section 4) is establishing the right definitions that make for a broadly applicable framework with precise approximation guarantees. Our framework supports arbitrary graph edit operations and both minimization and maximization problems, provided they jointly satisfy two properties: a combinatorial property called “stability” and an algorithmic property called “structural lifting”. Roughly, these properties bound the amount of change that OPT can undergo from each edit operation, but they are also parameterized to enable us to derive tighter bounds when the problem has additional structure. With the right definitions in place, the framework is simple: edit to the target class, apply an existing approximation algorithm, and lift.

The rest of Section 4 shows that this framework applies to many different graph optimization problems. In particular, we verify the stability and structural lifting properties, and combine all the necessary pieces, including our editing algorithms from Section 5 and existing approximation algorithms for structural graph classes. We summarize all of these results in Table 2 and formally define the framework in Section 4.1.

2.2 Editing to Bounded Degeneracy and Degree

We present two constant-factor bicriteria approximation algorithms for finding the fewest vertex or edge deletions to reduce the *degeneracy* to a target threshold r . The first approach (Section 5.1) uses the local ratio technique by Bar-Yehuda et al. [5] to establish that good-enough local choices result in a guaranteed approximation. The second approach (Section 5.2) is based on rounding a linear-programming relaxation of an integer linear program.

On the lower bound side, we show $o(\log(n/r))$ -approximation is impossible for vertex or edge edits (Section 6.1) when we forbid bicriteria approximation, i.e., when we must match the target

Problem	Edit type ψ	c'	c	Class \mathcal{C}_λ	$\rho(\lambda)$	runtime
INDEPENDENT SET (IS)	vertex deletion	1	0	degeneracy r	$\frac{1}{r+1}$	polytime
ANNOTATED DOMINATING SET (ADS)	vertex* deletion	0	1	degeneracy r	$O(r)$	polytime [4] ^a
INDEPENDENT SET (IS)	vertex deletion	1	0	treewidth w	1	$O(2^w n)$ [1]
ANNOTATED DOMINATING SET (ADS)	vertex* deletion	0	1	treewidth w	1	$O(3^w n)$
ANNOTATED (ℓ -)DOMINATING SET (ADS)	vertex* deletion	0	1	treewidth w	1	$O((2\ell + 1)^w n)$ [9]
CONNECTED DOMINATING SET (CDS)	vertex* deletion	0	3	treewidth w	1	$O(n^w)^b$
VERTEX COVER (VC)	vertex deletion	0	1	treewidth w	1	$O(2^w n)$ [1]
FEEDBACK VERTEX SET (FVS)	vertex deletion	0	1	treewidth w	1	$2^{O(w)} n^{O(1)}$ [18]
MINIMUM MAXIMAL MATCHING (MMM)	vertex deletion	0	1	treewidth w	1	$O(3^w n)^c$
CHROMATIC NUMBER (CRN)	vertex deletion	0	1	treewidth w	1	$w^{O(w)} n^{O(1)}$
INDEPENDENT SET (IS)	edge deletion	0	1	degeneracy r	$\frac{1}{r+1}$	polytime
DOMINATING SET (DS)	edge deletion	1	0	degeneracy r	$O(r)$	polytime [4]
(ℓ -)DOMINATING SET (DS)	edge deletion	1	0	treewidth w	1	$O((2\ell + 1)^w n)$ [9]
EDGE (ℓ -)DOMINATING SET (EDS)	edge deletion	1	1	treewidth w	1	$O((2\ell + 1)^w n)$ [9]
MAX-CUT (MC)	edge deletion	1	0	treewidth w	1	$O(2^w n)$ [25]

Table 2: Problems for which structural rounding (Theorem 4.1) results in approximation algorithms for graphs near the structural class \mathcal{C} , where the problem has a $\rho(\lambda)$ -approximation algorithm. We also give the associated stability (c') and lifting (c) constants, which are class-independent. The last column shows the running time of the $\rho(\lambda)$ -approximation algorithm for each problem provided an input graph from class \mathcal{C}_λ . We remark that vertex* is used to emphasize the rounding process has to pick the set of annotated vertices in the edited set carefully to achieve the associated stability and lifting constants.

^aThe approximation algorithm of [4] is analyzed only for DS; however, it is straightforward to show that the same algorithm achieves $O(r)$ -approximation for ADS as well.

^bOur rounding framework needs to solve an annotated version of CDS which can be solved in $O(n^w)$ by modifying the $O(w^w n)$ dynamic-programming approach of DS.

^cThe same dynamic-programming approach of DS can be modified to solve ADS and MMM in $O(3^w n)$.

degeneracy r exactly. This result is based on a reduction from SET COVER. A similar reduction proves $o(\log d)$ -inapproximability of editing to maximum degree d , which proves tightness (up to constant factors) of a known $O(\log d)$ -approximation algorithm [29]. This algorithm is also LP-based, employing LLL-based analysis to show that the standard randomized rounding approach works.

2.3 Editing to Bounded Weak c -Coloring Number

The *weak c -coloring number* can be used to characterize *bounded expansion*, and nicely generalizes the notion of bounded degeneracy, which corresponds to $c = 1$. (Note, however, that larger c values make for smaller graph classes; see Section 3.1.2 for details.)

In Section 6.2, we show that (non-bicriteria) $o(t)$ -approximation is NP-hard for any $c \geq 2$, by adapting our proof of lower bound for bounded degeneracy. This hardness result applies to vertex and edge deletions, as well as edge contractions.

2.4 Editing to Bounded Treewidth

In Section 5.5, we present a bicriteria approximation algorithm for finding the fewest vertex edits to reduce the *treewidth* to a target threshold w . Our approach builds on the deep separator structure inherent in treewidth. We combine ideas from Bodlaender's $O(\log n)$ -approximation algorithm for

treewidth with Feige et al.’s $O(\sqrt{\log w})$ -approximation algorithm for vertex separators [31] (where w is the target treewidth). In the end, we obtain a bicriteria $(O(\log^{1.5} n), O(\sqrt{\log w}))$ -approximation that runs in polynomial time on all graphs (in contrast to many previous treewidth algorithms). The tree decompositions that we generate are guaranteed to have $O(\log n)$ height. As a result, we also show a bicriteria $(O(\log^{1.5} n), O(\sqrt{\log w} \cdot \log n))$ -approximation result for pathwidth, based on the fact that the *pathwidth* is at most the width times the height of a tree decomposition.

On the lower bound side (Section 6.3), we prove a $o(\log w)$ -inapproximability result by another reduction from SET COVER. By a small modification, this lower bound also applies to editing to *bounded clique number*.

2.5 Editing to Treedepth 2

As a warmup to general treedepth results, we study the simple case of editing to graphs of treedepth 2, which are *star forests*. Here we do not need bicriteria approximation, though the problem remains hard, even to approximate within a constant factor. Assuming the Unique Games Conjecture (UGC), we show in Section 6.5 that VERTEX COVER reduces to this editing problem without a loss in OPT, implying a factor-2 lower bound for vertex edits. We also show APX-hardness for edge edits (Section 6.6). Our 4-approximation (Section 5.7) is based on a reduction to HITTING SET.

3 Preliminaries

This section defines several standard notions and graph classes, and is probably best used as a reference. The one exception is Section 3.2, which formally defines the graph-class editing problem $(\mathcal{C}_\lambda, \psi)$ -EDIT introduced in this paper.

Graph notation. We consider finite, loopless, simple graphs. Unless otherwise specified, we assume that graphs are undirected and unweighted. We denote a graph by $G = (V, E)$, and set $n = |V|$, $m = |E|$. Given $G = (V, E)$ and two vertices $u, v \in V$ we denote edges by $e(u, v)$ or (u, v) . We write $N(v) = \{u \mid (u, v) \in E\}$ for the set of neighbors of a vertex v ; the degree of v is $\deg(v) = |N(v)|$. In digraphs, in-neighbors and out-neighbors of a vertex v are defined using edges of the form (u, v) and (v, u) , respectively, and we denote in- and out-degree by $\deg^-(v), \deg^+(v)$, respectively. For the maximum degree of G we use $\Delta(G)$, or just Δ if context is clear. The clique number of G , denoted $\omega(G)$, is the size of the largest clique in G . Given some subset E' of the edges in G , we define $G[E']$ to be the subgraph of G induced on the edge set E' . Note that if every edge adjacent to some vertex v is in $E \setminus E'$, then v does not appear in the vertex set of $G[E']$.

3.1 Structural Graph Classes

In this section, we provide the necessary definitions for several structural graph classes (illustrated in Figure 1).

3.1.1 Degeneracy, cores, and shells

Definition 3.1. A graph G is *r -degenerate* if every subgraph contains a vertex of degree at most r ; the *degeneracy* is the smallest $r \in \mathbb{N}$ so that G is r -degenerate, and write $\text{degen}(G) = r$.

Much of the literature on degeneracy is in the context of the more refined notion of *k -cores*.

Definition 3.2. For a graph G and positive integer r , the *r -core* of G , $\text{core}_r(G)$, is the maximal subgraph of G with minimum degree r . The *r -shell* of G is $\text{core}_r(G) \setminus \text{core}_{r+1}(G)$.

Lemma 3.1 ([15, 62, 71]). *Given a graph $G = (V, E)$, the following are equivalent:*

1. *The degeneracy of G is at most r .*
2. *The $(r + 1)$ -core of G is empty.*
3. *There exists an ordering v_1, \dots, v_n of V so the degree of v_j in $G[\{v_j, \dots, v_n\}]$ is at most r .*

Lemma 3.2. *Given a graph $G = (V, E)$, if there exists an orientation of the edges in E so that $\deg^+(u) \leq r$ for all $u \in V$, then the degeneracy of G is at most $2r$.*

Proof. It is straightforward to verify that in any induced subgraph H of G , the same orientation of edges ensures that out-degree of each vertex $v \in V[H]$, $\deg^+_H(v) \leq r$. This in particular implies that H contains a vertex of degree at most $\frac{|E[H]|}{|V[H]|} \leq 2r$. Hence, $\text{degen}(G) \leq 2r$. \square

It immediately follows that a graph G has degeneracy r if and only if r is the largest number such that the r -core of G is non-empty. We note that having bounded degeneracy immediately implies bounded clique and chromatic numbers $\omega(G), \chi(G) \leq \text{degen}(G) + 1$ (the latter follows from a greedy coloring using the ordering from Lemma 3.1).

3.1.2 Weak coloring number

The **weak c -coloring number** was introduced along with the c -coloring number by Kierstead and Yang in [53], and it generalizes the notion of degeneracy in the following sense. As described in Lemma 3.1, the degeneracy of a graph can be understood as a worst-case bound on the forward degree of a vertex given an optimal ordering of the vertices. The weak c -coloring number bounds the number of vertices v reachable from u via a path of length at most c consisting of vertices that occur earlier than v in an ordering of the vertices. In fact, the weak 1-coloring number and degeneracy are equivalent notions.

Definition 3.3. (Section 2 [53]) *Let G be a finite, simple graph, let $L : V(G) \rightarrow \mathbb{N}$ be an injective function defining an ordering on the vertices of G , and let $\Pi(G)$ be the set of all possible such orderings. A vertex v is **weakly c -reachable** from u with respect to L if there exists a uv -path P such that $|P| \leq c$ and for all $w \in P$, $L(w) \leq L(v)$; we use $\text{wreach}_c(G, L, u)$ to denote the set of all such vertices. Let $\text{wscore}_c(G, L)$ be the $\max_{u \in V(G)} |\text{wreach}_c(G, L, u)|$. The **weak c -coloring number** of G is defined as $\text{wcol}_c(G) = \min_{L \in \Pi(G)} \text{wscore}_c(G, L)$.*

The weak c -coloring numbers provide useful characterizations for several structural graph classes:

Lemma 3.3 ([76, 75, 87]). *The weak c -coloring numbers characterize each following class \mathcal{C} :*

1. \mathcal{C} is nowhere dense $\iff \lim_{c \rightarrow \infty} \limsup_{G \in \mathcal{C}} \frac{\log(\text{wcol}_c(G))}{\log|G|} = 0$.
2. \mathcal{C} has bounded expansion $\iff \exists$ a function $f, \forall G \in \mathcal{C}, \forall c \in \mathbb{N} : \text{wcol}_c(G) \leq f(c)$.
3. \mathcal{C} has treedepth bounded by k $\iff \forall G \in \mathcal{C}, \forall c \in \mathbb{N} : \text{wcol}_c(G) \leq k$.

Additionally, the treewidth of a graph provides an upper bound on its weak coloring numbers. If a graph G has treewidth k , then $\text{wcol}_c(G) \leq \binom{k+c}{k}$, and there is an infinite family of graphs such that this bound is tight [38].

3.1.3 Treewidth, pathwidth, and treedepth

Perhaps the most heavily studied structural graph class is that of **bounded treewidth**; in this subsection we provide the necessary definitions for treewidth, pathwidth, and treedepth. Bounded treedepth is a stronger structural property than bounded pathwidth, and intuitively measures how “shallow” a tree the graph can be embedded in when edges can only occur between ancestor-descendent pairs.

Definition 3.4 ([81]). *Given a graph G , a **tree decomposition** of G consists of a collection \mathcal{Y} of subsets (called **bags**) of vertices in $V(G)$ together with a tree $T = (\mathcal{Y}, \mathcal{E})$ whose nodes \mathcal{Y} correspond to bags which satisfy the following properties:*

1. *Every $v \in V(G)$ is contained in a bag $B \in \mathcal{Y}$ (i.e. $\bigcup_{B \in \mathcal{Y}} B = V$).*
2. *For all edges $(u, v) \in E(G)$ there is a bag $B \in \mathcal{Y}$ that contains both endpoints u, v .*
3. *For each $v \in V(G)$, the set of bags containing v form a connected subtree of T (i.e. $\{B | v \in B, B \in \mathcal{Y}\}$ forms a subtree of T).*

The **width** of a tree decomposition is $\max_{B \in \mathcal{Y}} |B| - 1$, and the **treewidth** of a graph G , denoted $\text{tw}(G)$, is the minimum width of any tree decomposition of G .

All graphs that exclude a simple fixed planar minor H have bounded treewidth, indeed, treewidth $|V(H)|^{O(1)}$ [12]. Thus, every planar- H -minor-free graph class is a subclass of some bounded treewidth graph class.

Definition 3.5 ([81]). *A **path decomposition** is a tree decomposition in which the tree T is a path. The **pathwidth** of G , $\text{pw}(G)$, is the minimum width of any path decomposition of G .*

Definition 3.6 ([74]). *A **treedepth decomposition** of a graph G is an injective mapping $\psi : V(G) \rightarrow V(F)$ to a rooted forest F such that for each edge $(u, v) \in E(G)$, $\psi(u)$ is either an ancestor or a descendant of $\psi(v)$ in F . The **depth** of a treedepth decomposition is the height of the forest F . The **treedepth** of G is the minimum depth of any treedepth decomposition of G .*

3.2 Editing Problems

This paper is concerned with algorithms that edit graphs into a desired structural class, while guaranteeing an approximation ratio on the size of the edit set. Besides its own importance, editing graphs into structural classes plays a key role in our structural rounding framework for approximating optimization problems on graphs that are “close” to structural graph classes (see Section 4). The basic editing problem is defined as follows relative to an edit operation ψ such as vertex deletion, edge deletion, or edge contraction:

(\mathcal{C}, ψ) -EDIT

Input: An input graph $G = (V, E)$, family \mathcal{C} of graphs, edit operation ψ
Problem: Find k edits $\psi_1, \psi_2, \dots, \psi_k$ such that $\psi_k(\psi_{k-1}(\dots \psi_2(\psi_1(G)) \dots)) \in \mathcal{C}$.
Objective: Minimize k

The literature has limited examples of approximation algorithms for specific edit operations and graph classes. Most notably, Fomin et al. [34] studies (\mathcal{C}, ψ) -EDIT for vertex deletions into the class of **planar- H -minor-free graphs** (graphs excluding a fixed planar graph H).¹

¹More generally, Fomin et al. [34] consider editing to the class of graphs excluding a finite family \mathcal{F} of graphs at least one of which is planar, but as we just want the fewest edits to put the graph in some structural class, we focus on the case $|\mathcal{F}| = 1$.

In addition to fixed-parameter algorithms (for when k is small), they give a c_H -approximation algorithm for (\mathcal{C}, ψ) -EDIT where the constant $c_H = \Omega\left(2^{2^{|V(H)|^3}}\right)$ is rather large.

Most of the graph classes we consider consist of graphs where some parameter λ (clique number, maximum degree, degeneracy, weak c -coloring number, or treewidth) is bounded. Thus we can think of the graph class \mathcal{C} as in fact being a parameterized family \mathcal{C}_λ . (For planar- H -minor-free, λ could be $|V(H)|$.) In addition to approximating just the number of edits, we can also loosen the graph class we are aiming for, and approximate the parameter value λ for the family \mathcal{C}_λ . Thus we obtain a **bicriteria problem** which can be formalized as follows:

$(\mathcal{C}_\lambda, \psi)$ -EDIT

Input: An input graph $G = (V, E)$, parameterized family \mathcal{C}_λ of graphs, a target parameter value λ^* , edit operation ψ

Problem: Find k edits $\psi_1, \psi_2, \dots, \psi_k$ such that $\psi_k(\psi_{k-1}(\dots\psi_2(\psi_1(G))\dots)) \in \mathcal{C}_\lambda$ where $\lambda \geq \lambda^*$.

Objective: Minimize k .

Definition 3.7. An algorithm for $(\mathcal{C}_\lambda, \psi)$ -EDIT is a **(bicriteria) (α, β) -approximation** if it guarantees that the number of edits is at most α times the optimal number of edits into \mathcal{C}_λ , and that $\lambda \leq \beta \cdot \lambda^*$.

See Table 1 for a complete list of the problems considered, along with their abbreviations.

3.3 Hardness and Reductions

One of our contributions in this paper is providing hardness of approximation for several important instances of (\mathcal{C}, ψ) -EDIT defined in Section 3.2. Here, we describe the necessary definitions for approximation-preserving reductions as well as known approximability hardness results for several key problems.

3.3.1 Approximation preserving reductions

A classic tool in proving approximation hardness is the **L-reduction**, which linearly preserves approximability features [79], and implies PTAS reductions.

Definition 3.8. Let A and B be minimization problems with cost functions Cost_A and Cost_B , respectively. An **L-reduction** is a pair of functions f and g such that:

1. f and g are polynomial time computable,
2. for an instance x of A , $f(x)$ is an instance of B ,
3. for a feasible solution y' of B , $g(y')$ is a feasible solution of A ,
4. there exists a constant c_1 such that

$$\text{OPT}_B(f(x)) \leq c_1 \text{OPT}_A(x), \tag{1}$$

5. and there exists a constant c_2 such that

$$\text{Cost}_A(g(y')) - \text{OPT}_A(x) \leq c_2 (\text{Cost}_B(y') - \text{OPT}_B(f(x))). \tag{2}$$

In many cases, we will establish a stronger form of reduction known as a *strict reduction*, which implies an L -reduction [54, 78].

Definition 3.9. Let A and B be minimization problems with cost functions Cost_A and Cost_B , respectively. A *strict reduction* is a pair of functions f and g such that:

1. f and g are polynomial time computable,
2. for an instance x of A , $f(x)$ is an instance of B ,
3. for a feasible solution y' of B , $g(y')$ is a feasible solution of A ,
4. and it holds that

$$\frac{\text{Cost}_A(g(y'))}{\text{OPT}_A(x)} \leq \frac{\text{Cost}_B(y')}{\text{OPT}_B(f(x))}. \quad (3)$$

We note that to prove a strict reduction, it suffices to demonstrate that $\text{OPT}_A(x) = \text{OPT}_B(f(x))$ and $\text{Cost}_A(g(y')) \leq \text{Cost}_B(y')$.

3.3.2 Hard problems

As mentioned earlier, our approximation hardness results for the instances of (\mathcal{C}, ψ) -EDIT studied in this paper are via reductions from SET COVER, VERTEX COVER and MINIMUM DOMINATING SET- B (MINIMUM DOMINATING SET in graphs of maximum degree B). We now formally define each of these, and state the associated hardness of approximation results used.

SET COVER (SC)

Input: A universe \mathcal{U} of elements and a collection \mathcal{F} of subsets of the universe.

Problem: Find a minimum size subset $X \subseteq \mathcal{F}$ that covers \mathcal{U} : $\bigcup_{S \in X} S = \mathcal{U}$.

Theorem 3.4 ([24, 30, 64, 72, 73]). *It is NP-hard to approximate SET COVER(\mathcal{U}, \mathcal{F}) within a factor of $(1 - \varepsilon) \ln(|\mathcal{U}|)$ for any $\varepsilon > 0$. Moreover, this holds for instances where $|\mathcal{F}| \leq \text{poly}(|\mathcal{U}|)$.*

We remark that this result is tight, due to an $(\ln |\mathcal{U}|)$ -approximation algorithm for SC [49].

Theorem 3.5 ([84]). *There exists a constant $C > 0$ so that it is NP-hard to approximate SET COVER(\mathcal{U}, \mathcal{F}) within a factor of $(\ln \Delta - C \ln \ln \Delta)$, where $\Delta = \max_{S \in \mathcal{F}} |S|$. Moreover, in the hard instances, $\Delta \geq f_{\max}$ where f_{\max} is the maximum frequency of an element of \mathcal{U} in \mathcal{F} .*

k -UNIFORM SET COVER (k -USC)

Input: A universe \mathcal{U} of elements and a collection \mathcal{F} of subsets of the universe such that every element of \mathcal{U} is contained in exactly k sets in \mathcal{F} .

Problem: Find a minimum size subset $X \subseteq \mathcal{F}$ that covers \mathcal{U} : $\bigcup_{S \in X} S = \mathcal{U}$.

Theorem 3.6 (Theorem 1.1 [22]). *For any constant $k \geq 3$, it is NP-hard to approximate k -USC within a factor of $(k - 1 - \varepsilon)$ for any $\varepsilon > 0$.*

Note that k is assumed to be constant with respect to $|\mathcal{U}|$ in this result. However, the same paper provides a slightly weaker hardness result when k is super-constant with respect to $|\mathcal{U}|$.

Theorem 3.7 (Theorem 6.2 [22]). *There exists a constant $b > 0$ so that there is no polynomial time algorithm for approximating k -USC within a factor of $(\lfloor k/2 \rfloor - 0.01)$ when $4 \leq k \leq (\log |\mathcal{U}|)^{1/b}$, unless $NP \subseteq DTIME(n^{O(\log \log n)})$. This holds for instances where $|\mathcal{F}| \leq |\mathcal{U}|$.*

VERTEX COVER (VC)

Input: A graph $G = (V, E)$.

Problem: Find a minimum size set of vertices $X \subseteq V$ s.t. $G[V \setminus X]$ has no edge.

Theorem 3.8 ([23, 52]). *It is NP-hard to approximate VERTEX COVER within a factor of 1.3606. Moreover, assuming UGC, VC has no $(2 - \varepsilon)$ approximation for $\varepsilon > 0$.*

MINIMUM DOMINATING SET-B (DSB)

Input: An undirected graph $G = (V, E)$ with maximum degree at most B .

Problem: Find a minimum size set of vertices $C \subseteq V$ such that every vertex in V is either in C or is adjacent to a vertex in C .

Theorem 3.9 ([84]). *There are constants $C > 0$ and $B_0 \geq 3$ so that for every $B \geq B_0$ it is NP-hard to approximate MINIMUM DOMINATING SET-B within a factor of $\ln B - C \ln \ln B$.*

The best known constants C for small B in Theorem 3.9 are given in [14].

3.4 Optimization Problems

We conclude our preliminaries with formal definitions of several additional optimization problems for which we give new approximation algorithms via structural rounding in Section 4.

ℓ -DOMINATING SET (ℓ -DS)

Input: An undirected graph $G = (V, E)$ and a positive integer ℓ .

Problem: Find a minimum size set of vertices $C \subseteq V$ s.t. every vertex in V is either in C or is connected by a path of length at most ℓ to a vertex in C .

EDGE ℓ -DOMINATING SET (ℓ -EDS)

Input: An undirected graph $G = (V, E)$ and a positive integer ℓ .

Problem: Find a minimum size set of edges $C \subseteq E$ s.t. every edge in E is either in C or is connected by a path of length at most ℓ to an edge in C .

When $\ell = 1$, these are DOMINATING SET (DS) and EDGE DOMINATING SET (EDS).

ANNOTATED (ℓ -)DOMINATING SET (ADS)

Input: An undirected graph $G = (V, E)$, a subset of vertices $B \subseteq V$ and a positive integer.

Problem: Find a minimum size set of vertices $C \subseteq V$ s.t. every vertex in B is either in C or is connected by a path of length at most ℓ to a vertex in C .

Note that when $B = V$, ANNOTATED (ℓ -)DOMINATING SET becomes (ℓ -)DOMINATING SET².

ℓ -INDEPENDENT SET (ℓ -IS)

Input: A graph $G = (V, E)$.

Problem: Find a maximum size set of vertices $X \subseteq V$ s.t. no two vertices in X are connected by a path of length $\leq \ell$.

When $\ell = 1$, we call this INDEPENDENT SET (IS).

FEEDBACK VERTEX SET (FVS)

Input: A graph $G = (V, E)$.

Problem: Find a minimum size set of vertices $X \subseteq V$ s.t. $G \setminus X$ has no cycles.

MINIMUM MAXIMAL MATCHING (MMM)

Input: A graph $G = (V, E)$.

Problem: Find a minimum size set of edges $X \subseteq E$ s.t. X is a maximal matching.

CHROMATIC NUMBER (CRN)

Input: A graph $G = (V, E)$.

Problem: Find a minimum size coloring of G s.t. adjacent vertices are different colors.

MAX-CUT (MC)

Input: A graph $G = (V, E)$.

Problem: Find a partition of the nodes of G into sets S and $V \setminus S$ such that the number of edges from S to $V \setminus S$ is greatest.

4 Structural Rounding

In this section, we show how approximation algorithms for a structural graph class can be extended to graphs that are near that class, provided we can find a certificate of being near the class. These results thus motivate our results in later sections about editing to structural graph classes. Our general approach, which we call *structural rounding*, is to apply existing approximation algorithms on the edited (“rounded”) graph in the class, then “lift” that solution to solve the original graph, while bounding the loss in solution quality throughout.

4.1 General Framework

First we define our notion of “closeness” in terms of a general family ψ of allowable graph edit operations (e.g., vertex deletion, edge deletion, edge contraction):

²The ANNOTATED DOMINATING SET problem has also been studied in the literature as *subset dominating set problem* in [39, 43].

Definition 4.1. A graph G' is γ -**editable** from a graph G under edit operation ψ if there is a sequence of $k \leq \gamma$ edits $\psi_1, \psi_2, \dots, \psi_k$ of type ψ such that $G' = \psi_k(\psi_{k-1}(\dots \psi_2(\psi_1(G)) \dots))$. A graph G is γ -**close** to a graph class \mathcal{C} under ψ if some $G' \in \mathcal{C}$ is γ -editable from G under ψ .

To transform an approximation algorithm for a graph class \mathcal{C} into an approximation algorithm for graphs γ -close to \mathcal{C} , we will need two properties relating the optimization problem and the type of edits:³

Definition 4.2. A graph minimization (resp. maximization) problem Π is **stable** under an edit operation ψ with constant c' if $\text{OPT}_\Pi(G') \leq \text{OPT}_\Pi(G) + c'\gamma$ (resp. $\text{OPT}_\Pi(G') \geq \text{OPT}_\Pi(G) - c'\gamma$) for any graph G' that is γ -editable from G under ψ . In the special case where $c' = 0$, we call Π **closed** under ψ . When ψ is vertex deletion, closure is equivalent to the graph class defined by $\text{OPT}_\Pi(G) \leq \lambda$ (resp. $\text{OPT}_\Pi(G) \geq \lambda$) being **hereditary**; we also call Π **hereditary**.

Definition 4.3. A minimization (resp. maximization) problem Π can be **structurally lifted** with respect to an edit operation ψ with constant c if, given any graph G' that is γ -editable from G under ψ , and given the corresponding edit sequence $\psi_1, \psi_2, \dots, \psi_k$ with $k \leq \gamma$, a solution S' for G' can be converted in polynomial time to a solution S for G such that $\text{Cost}_\Pi(S) \leq \text{Cost}_\Pi(S') + c \cdot k$ (resp. $\text{Cost}_\Pi(S) \geq \text{Cost}_\Pi(S') - c \cdot k$).

Now we can state the main result of structural rounding:

Theorem 4.1 (Structural Rounding Approximation). *Let Π be a minimization (resp. maximization) problem that is stable under the edit operation ψ with constant c' and that can be structurally lifted with respect to ψ with constant c . If Π has a polynomial-time $\rho(\lambda)$ -approximation algorithm in the graph class \mathcal{C}_λ , and $(\mathcal{C}_\lambda, \psi)$ -EDIT has a polynomial-time (α, β) -approximation algorithm, then there is a polynomial-time $((1 + c'\alpha\delta) \cdot \rho(\beta\lambda) + c\alpha\delta)$ -approximation (resp. $((1 - c'\alpha\delta) \cdot \rho(\beta\lambda) - c\alpha\delta)$ -approximation) algorithm for Π on any graph that is $(\delta \cdot \text{OPT}_\Pi(G))$ -close to the class \mathcal{C}_λ .*

Proof. We write $\text{OPT}(G)$ for $\text{OPT}_\Pi(G)$. Let G be a graph that is $(\delta \cdot \text{OPT}(G))$ -close to the class \mathcal{C}_λ . By Definition 3.7, the polynomial-time (α, β) -approximation algorithm finds edit operations $\psi_1, \psi_2, \dots, \psi_k$ where $k \leq \alpha\delta \cdot \text{OPT}(G)$ such that $G' = \psi_k(\psi_{k-1}(\dots \psi_2(\psi_1(G)) \dots)) \in \mathcal{C}_{\beta\lambda}$.⁴ Let $\rho = \rho(\beta\lambda)$ be the approximation factor we can attain on the graph $G' \in \mathcal{C}_{\beta\lambda}$.

First we prove the case when Π is a minimization problem. Because Π has a ρ -approximation in $\mathcal{C}_{\beta\lambda}$ (where $\rho > 1$), we can obtain a solution S' with cost at most $\rho \cdot \text{OPT}(G')$ in polynomial time. Applying structural lifting (Definition 4.3), we can use S' to obtain a solution S for G with $\text{Cost}(S) \leq \text{Cost}(S') + ck \leq \text{Cost}(S') + c\alpha\delta \cdot \text{OPT}(G)$ in polynomial time. Because Π is stable under ψ with constant c' ,

$$\text{OPT}(G') \leq \text{OPT}(G) + c'k \leq \text{OPT}(G) + c'\alpha\delta \cdot \text{OPT}(G) = (1 + c'\alpha\delta) \text{OPT}(G),$$

and we have

$$\begin{aligned} \text{Cost}(S) &\leq \rho \cdot \text{OPT}(G') + c\alpha\delta \cdot \text{OPT}(G) \\ &\leq \rho(1 + c'\alpha\delta) \text{OPT}(G) + c\alpha\delta \cdot \text{OPT}(G) \\ &= (\rho + \rho c'\alpha\delta + c\alpha\delta) \text{OPT}(G), \end{aligned}$$

proving that we have a polynomial time $(\rho + (c + c'\rho)\alpha\delta)$ -approximation algorithm as required.

³These conditions are related to, but significantly generalize, the “separation property” from the bidimensionality framework for PTASs [20].

⁴We assume that $C_i \subseteq C_j$ for $i \leq j$, or equivalently, that $\rho(\lambda)$ is monotonically increasing in λ .

Next we prove the case when Π is a maximization problem. Because Π has a ρ -approximation in \mathcal{C} (where $\rho < 1$), we can obtain a solution S' with cost at least $\rho \cdot \text{OPT}(G')$ in polynomial time. Applying structural lifting (Definition 4.3), we can use S' to obtain a solution S for G with $\text{Cost}(S) \geq \text{Cost}(S') - ck \geq \text{Cost}(S') - c\alpha\delta \cdot \text{OPT}(G)$ in polynomial time. Because Π is stable under ψ with constant c' ,

$$\text{OPT}(G') \geq \text{OPT}(G) - c'k \geq \text{OPT}(G) - c'\alpha\delta \cdot \text{OPT}(G) = (1 - c'\alpha\delta) \text{OPT}(G),$$

and we have

$$\begin{aligned} \text{Cost}(S) &\geq \rho \cdot \text{OPT}(G') - c\alpha\delta \cdot \text{OPT}(G) \\ &\geq \rho(1 - c'\alpha\delta) \text{OPT}(G) - c\alpha\delta \cdot \text{OPT}(G) \\ &= (\rho - (c + c'\rho)\alpha\delta) \text{OPT}(G), \end{aligned}$$

proving that we have a polynomial-time $(\rho - (c + c'\rho)\alpha\delta)$ -approximation algorithm as required. Note that this approximation is meaningful only when $\rho > (c + c'\rho)\alpha\delta$. \square

To apply Theorem 4.1, we need four ingredients: (a) a proof that the problem of interest is stable under some edit operation (Definition 4.2); (b) a polynomial-time (α, β) -approximation algorithm for editing under this operation (Definition 3.7); (c) a structural lifting algorithm (Definition 4.3); and (d) an approximation algorithm for the target class \mathcal{C} .

In the remainder of this section, we show how this framework applies to many problems and graph classes, as summarized in Table 2 on page 6. Most of our approximation algorithms depend on our editing algorithms described in Section 5. We present the problems ordered by edit type, as listed in Table 2.

Structural rounding for annotated problems. We refer to graph optimization problems where the input consists of both a graph and subset of annotated vertices/edges as *annotated* problems (see ANNOTATED DOMINATING SET in Section 3.4). Hence, in our rounding framework, we have to carefully choose the set of annotated vertices/edges in the edited graph to guarantee small *lifting* and *stability* constants. To emphasize the difference compared to “standard” structural rounding, we denote the edit operations as vertex^* and edge^* in the annotated cases. Moreover, we show that we can further leverage the flexibility of annotated rounding to solve *non-annotated* problems that cannot normally be solved via structural rounding. In Section 4.4, we consider applications of annotated rounding for both annotated problems such as ANNOTATED DOMINATING SET and non-annotated problems such as CONNECTED DOMINATING SET.

4.2 Vertex Deletions

For each problem, we show stability and structural liftability, and use these to conclude approximation algorithms. Because IS is the only maximization problem we first consider in this section, we consider it separately.

Lemma 4.2. INDEPENDENT SET *is stable under vertex deletion with constant $c' = 1$.*

Proof. Given a graph G and any set $X \subseteq V(G)$ with $|X| \leq \gamma$, let $G' = G[V \setminus X]$. For any independent set $Y \subset V(G)$, $Y' = Y \setminus X$ is also an independent set in G' with size $|Y'| \geq |Y| - |X|$, which is bounded below by $|Y| - \gamma$. In particular, for Y optimal in G we have $|Y'| \geq \text{OPT}(G) - \gamma$, and so $\text{OPT}(G') \geq \text{OPT}(G) - \gamma$. \square

Lemma 4.3. INDEPENDENT SET can be structurally lifted with respect to vertex deletion with constant $c = 0$.

Proof. An independent set in $G' = G \setminus X$ is also an independent set in G . Thus, a solution S' for G' yields a solution S for G such that $\text{Cost}_{\text{IS}}(S') = \text{Cost}_{\text{IS}}(S)$. \square

Corollary 4.4. For graphs $(\delta \cdot \text{OPT}(G))$ -close to a graph class \mathcal{C}_λ via vertex deletions, INDEPENDENT SET has the following approximations. For degeneracy r , IS has a $(1 - 4\delta)/(4r + 1)$ -approximation, for treewidth w such that $w\sqrt{\log w} = O(\log n)$, IS has a $(1 - O(\delta \log^{1.5} n))$ -approximation, and for planar- H -minor-free, IS has a $(1 - c_H\delta)$ -approximation.

Proof. We apply Theorem 4.1 using stability with $c' = 1$ (Lemma 4.2) and structural lifting with $c = 0$ (Lemma 4.3). The independent-set approximation algorithm and the editing approximation algorithm depend on the class \mathcal{C}_λ .

For degeneracy r , we use our $(4, 4)$ -approximate editing algorithm (Section 5.2.1) and a simple $1/(r + 1)$ -approximation algorithm for independent set: the r -degeneracy ordering on the vertices of a graph gives a canonical $(r + 1)$ -coloring, and the pigeonhole principle guarantees an independent set of size at least $|V|/(r + 1)$, which is at least $1/(r + 1)$ times the maximum independent set. Thus $\alpha = \beta = 4$ and $\rho(\beta r) = 1/(\beta r + 1)$, resulting in an approximation factor of $(1 - 4\delta)/(4r + 1)$.

For treewidth w such that $w\sqrt{\log w} = O(\log n)$, we use our $(O(\log^{1.5} n), O(\sqrt{\log w}))$ -approximate editing algorithm (Section 5.5) and an exact algorithm for independent set [7, 1] given a tree decomposition of width $O(\log n)$ of the edited graph. Thus $\alpha = O(\log^{1.5} n)$ and $\rho = 1$, resulting in an approximation factor of $1 - O(\log^{1.5} n)\delta$.

For planar- H -minor-free, we use Fomin's c_H -approximate editing algorithm [34] and the same exact algorithm for IS in bounded treewidth (as any planar- H -minor-free graph has bounded treewidth [12]). Thus $\alpha = c_H$ and $\rho = 1$, resulting in an approximation factor of $1 - c_H\delta$. \square

Lemma 4.5. The problems VERTEX COVER, FEEDBACK VERTEX SET, MINIMUM MAXIMAL MATCHING, and CHROMATIC NUMBER are hereditary (closed under vertex deletion).

Proof. Let G be a graph, and $G' = G \setminus X$ where $X \subseteq V(G)$. Any vertex cover in G remains a cover in G' because $E(G') \subseteq E(G)$, so VC is hereditary.

Let S be a feedback vertex set in G and $S' = S \setminus X$. For FVS, we observe that removing vertices can only decrease the number of cycles in the graph. Deleting a vertex in S breaks all cycles it is a part of and, thus, the cycles no longer need to be covered by a vertex in the feedback vertex set of G' . Deleting a vertex not in S can only decrease the number of cycles, and, thus, all cycles in G' are still covered by S' . Hence, FVS is hereditary.

For MMM, deleting vertices with adjacent edges not in the matching only decreases the number of edges; thus, the original matching is still a matching in the edited graph. Deleting vertices adjacent to an edge in the matching means that at most one edge in the matching per deleted vertex is deleted. For each edge in the matching with one of its two endpoints deleted, at most one additional edge (an edge adjacent to its other endpoint) needs to be added to maintain the maximal matching. Thus, the size of the maximal matching does not increase and MMM is hereditary.

CRN is trivially hereditary because deleting vertices can only decrease the number of colors necessary to color the graph. \square

Lemma 4.6. The problems VERTEX COVER, FEEDBACK VERTEX SET, MINIMUM MAXIMAL MATCHING, and CHROMATIC NUMBER can be structurally lifted with respect to vertex deletion with constant $c = 1$.

Proof. Let G be a graph, and $G' = G \setminus X$ where $X \subseteq V(G)$. Let S' be a solution to optimization problem Π on G' . We will show that $S \subseteq S' \cup X$ is a valid solution to Π on G for each Π listed in the Lemma.

Given a solution S' to VC for the graph G' , the only edges not covered by S' in G' are edges between X and G' and between two vertices in X . Both sets of such edges are covered by X . Thus, $S = S' \cup X$ is a valid cover for G .

Given a solution S' to FVS for the graph G' , the only cycles not covered by S' in G' are cycles that include a vertex in X . Thus, $S = S' \cup X$ is a valid feedback vertex set for G since X covers all newly introduced cycles in G .

Given a solution S' to MMM for the graph G' , the only edges not in the matching and not adjacent to edges in the matching are edges between X and G' and edges between two vertices in X . Thus, any additional edges added to the maximal matching will come from X , and $S \subseteq S' \cup X$ (by picking edges to add to the maximal matching greedily for example) is a valid solution.

Given a solution S' to CRN for the graph G' , the only vertices that could violate the coloring of the graph G' are vertices in X . Making each vertex in X a different color from each other as well as the colors in G' creates a valid coloring of G . Thus, $S = S' \cup X$ is a valid coloring. \square

Corollary 4.7. *The problems VERTEX COVER, and FEEDBACK VERTEX SET have $(1+O(\delta \log^{1.5} n))$ -approximations for graphs $(\delta \cdot \text{OPT}(G))$ -close to treewidth w via vertex deletions where $w\sqrt{\log w} = O(\log n)$; and $(1 + c_H\delta)$ -approximations for graphs $(\delta \cdot \text{OPT}(G))$ -close to planar- H -minor-free via vertex deletions.*

Proof. We apply Theorem 4.1 using stability with constant $c' = 0$ (Lemma 4.5) and structural lifting with constant $c = 1$ (Lemma 4.6).

For treewidth w , we use our $(O(\log^{1.5} n), O(\sqrt{\log w}))$ -approximate editing algorithm (Section 5.5) and an exact polynomial-time algorithm for the problem of interest [7, 1, 18] given the tree-decomposition of width $O(w\sqrt{\log w})$ of the edited graph. Thus $\alpha = O(\log^{1.5} n)$ and $c = 1$, resulting in an approximation factor of $1 + O(\log^{1.5} n)\delta$. Note that since the edited graph has treewidth $O(w\sqrt{\log w}) = O(\log n)$, the exact algorithm runs in polynomial-time. For planar- H -minor-free graphs, we use Fomin's c_H -approximate editing algorithm [34] and the same exact algorithm for bounded treewidth (as any planar- H -minor-free graph has bounded treewidth [12]). Thus $\alpha = c_H$ and $c = 1$, resulting in an approximation factor of $1 + c_H\delta$. \square

Corollary 4.8. *The problems MINIMUM MAXIMAL MATCHING, and CHROMATIC NUMBER have $(1 + O(\delta \log^{1.5} n))$ -approximations for graphs $(\delta \cdot \text{OPT}(G))$ -close to treewidth w via vertex deletions where $w \log^{1.5} w = O(\log n)$; and $(1 + c_H\delta)$ -approximations for graphs $(\delta \cdot \text{OPT}(G))$ -close to planar- H -minor-free via vertex deletions.*

Proof. We apply Theorem 4.1 using stability with constant $c' = 0$ (Lemma 4.5) and structural lifting with constant $c = 1$ (Lemma 4.6).

For treewidth w , we use our $(O(\log^{1.5} n), O(\sqrt{\log w}))$ -approximate editing algorithm (Section 5.5) and an exact algorithm for the problem of interest [7] given a tree-decomposition of width $O(w\sqrt{\log w})$ of the edited graph. Thus $\alpha = O(\log^{1.5} n)$ and $c = 1$, resulting in an approximation factor of $1 + O(\log^{1.5} n)\delta$. Note that since the edited graph has treewidth $O(w \log^{1.5} w) = O(\log n)$, the exact algorithm runs in polynomial-time. For planar- H -minor-free graphs, we use Fomin's c_H -approximate editing algorithm [34] and the same exact algorithm for bounded treewidth (as any planar- H -minor-free graph has bounded treewidth [12]). Thus $\alpha = c_H$ and $c = 1$, resulting in an approximation factor of $1 + c_H\delta$. \square

4.3 Edge Deletions

Theorem 4.9. *For graphs $(\delta \cdot \text{OPT}(G))$ -close to degeneracy r via edge deletions:*

- INDEPENDENT SET has a $(1/(3r + 1) - 3\delta)$ -approximation.
- DOMINATING SET has an $O((1 + \delta)r)$ -approximation.

For graphs $(\delta \cdot \text{OPT}(G))$ -close to treewidth w via edge deletions:

- (ℓ) -DOMINATING SET and EDGE (ℓ) -DOMINATING SET have $(1 + O(\delta \log n \log \log n))$ -approximations when $w \log w = O(\log_\ell n)$.
- MAX-CUT has a $(1 - O(\delta \log n \log \log n))$ -approximation when $w \log w = O(\log n)$.

We now consider the edit operation of edge deletion. For each problem, we show stability and structural liftability, and use these to conclude approximation algorithms.

Lemma 4.10. *For $\ell \geq 1$, (ℓ) -INDEPENDENT SET is stable under edge deletion with constant $c' = 0$.*

Proof. Given G and any set $X \subseteq E(G)$ with $|X| \leq \gamma$, let $G' = G[E \setminus X]$. For any (ℓ) -independent set $Y \subseteq V(G)$, $Y' = Y$ is also an (ℓ) -independent set in G' . Then $\text{OPT}(G') \geq |Y'| = |Y|$, and so for optimal Y , $\text{OPT}(G') \geq \text{OPT}(G)$. \square

Lemma 4.11. *For $\ell \geq 1$, (ℓ) -INDEPENDENT SET can be structurally lifted with respect to edge deletion with constant $c = 1$.*

Proof. Given a graph G and $X \subseteq E(G)$, let $G' = G[E \setminus X]$. Let $Y' \subseteq V(G')$ be an (ℓ) -independent set in G' , and consider the same vertex set Y' in G . Assume that the edit set is a single edge, $X = \{(u, v)\}$. We claim there exists a subset of Y' with size at least $|Y'| - 1$ which is still an (ℓ) -independent set in G .

For convenience, we let $d(\cdot, \cdot) := d_G(\cdot, \cdot)$ for the remainder of this proof. Suppose there are four distinct nodes $a, b, f, g \in Y'$ such that $d(a, b) \leq \ell$ and $d(f, g) \leq \ell$ in G . Since these nodes are in Y' , we know $d_{G'}(a, b), d_{G'}(f, g) \geq \ell + 1$, hence, any shortest path from a to b in G must use the edge (u, v) in order to have length $\leq \ell$. WLOG we can assume the a - b path goes from a to u to v to b , and so $d(a, u) + 1 + d(v, b) \leq \ell$. Similarly we can assume the f - g path goes from f to v to u to g , and so $d(f, v) + 1 + d(u, g) \leq \ell$. We now argue that the shortest paths in G from a to u , v to b , f to v , and u to g do not use the edge (u, v) and are therefore also paths in G' . Suppose not and consider WLOG the case when a shortest path from a to u contains (u, v) . Then concatenating the subpath from a to v with a shortest path from v to b gives an a, b -path of length $d(a, u) - 1 + d(v, b) < \ell$, which does not use the edge (u, v) (and is thus a path in G' , contradicting (ℓ) -independence of Y').

Now consider the paths $(a$ to u to $g)$ and $(f$ to v to $b)$. Let $\ell_A = d(a, u) + d(u, g)$ and $\ell_F = d(f, v) + d(v, b)$, and note that $\ell_A + \ell_F = d(a, u) + d(v, b) + d(f, v) + d(u, g)$, which is $\leq 2\ell - 2$. So at least one of ℓ_A or ℓ_F must be $\leq \ell - 1$, a contradiction.

Three cases remain: (1) Y' contains exactly two vertices connected by a path of length $\leq \ell$ in G ; (2) Y' contains three distinct vertices pair-wise connected by paths of length $\leq \ell$ in G ; or (3) Y' contains one vertex, a , connected to two or more other vertices of Y' by paths of length $\leq \ell$ in G . In the first case, Y' contains a, b with $d(a, b) \leq \ell$; then removing either endpoint from Y' yields an (ℓ) -independent set of size $|Y'| - 1$ in G .

We now show the second case cannot occur. Suppose that $d(b, c), d(a, b), d(a, c) \leq \ell$ for $a, b, c \in Y'$. Note that each vertex is within distance $\ell/2$ of at least one of the vertices u or v . By the

pigeonhole principle, some two of a, b, c must be within $\ell/2$ of the same endpoint of (u, v) ; say vertices a and b are within $\ell/2$ of u WLOG; this implies $d_{G'}(a, b) \leq \ell$, a contradiction.

Finally, in the third case, Y' contains a node a and a subset S so that $|S| \geq 2$, $d(a, s) \leq \ell$ for all $s \in S$ and $d(s_1, s_2) > \ell$ for all $s_1 \neq s_2$ in S . Further, we know no other pair of nodes in Y' is at distance at most ℓ in G (since then we would have two disjoint pairs at distance at most ℓ , a case we already handled). In this setting, $Y' \setminus \{a\}$ is an $(\ell-)$ independent set of size $|Y'| - 1$ in G . This proves that adding a single edge to G' will reduce the size of the $(\ell-)$ independent set Y' by no more than one, so by induction the lemma holds. \square

Corollary 4.12. INDEPENDENT SET has a $(1/(3r+1) - 3\delta)$ -approximation for graphs $(\delta \cdot \text{OPT}(G))$ -close to degeneracy r via edge deletions.

Proof. We apply Theorem 4.1 using stability with constant $c' = 0$ (Lemma 4.2) and structural lifting with constant $c = 1$ (Lemma 4.3). We use our $(3, 3)$ -approximate editing algorithm (Corollary 5.17) and the $1/(r+1)$ -approximation algorithm for independent set described in the proof of Corollary 4.4. Thus $\alpha = \beta = 3$ and $\rho(\beta r) = 1/(\beta r + 1)$, resulting in an approximation factor of $1/(3r+1) - 3\delta$. \square

Note that Corollary 4.12 only applies to IS and not ℓ -IS.

Lemma 4.13. The problems $(\ell-)$ DOMINATING SET and EDGE $(\ell-)$ DOMINATING SET are stable under edge deletion with constant $c' = 1$.

Proof. Given G and any set $X \subseteq E(G)$ with $|X| \leq \gamma$, let $G' = G[E \setminus X]$, and let Y be a minimum $(\ell-)$ dominating set on G . Each vertex v may be $(\ell-)$ dominated by multiple vertices on multiple paths, which we refer to as v 's *dominating paths*.

Consider all vertices for which a specific edge (u, v) is on all of their dominating paths in G . We refer to each of these vertices as (u, v) -dependent. Note that if we traverse all dominating paths from each (u, v) -dependent vertex, (u, v) is traversed in the same direction each time. Assume WLOG (u, v) is traversed with u before v , implying u is not (u, v) -dependent but v may be. Now if (u, v) is deleted, then $Y \cup \{v\}$ is a $(\ell-)$ dominating set on the new graph. Therefore for each edge (u, v) in X we must add at most one vertex to the $(\ell-)$ dominating set. Thus if Y' is a minimum $(\ell-)$ dominating set on G' then $|Y'| \leq |Y| + \gamma$ and DS is stable under edge deletion with constant $c' = 1$.

Now let Z be a minimum edge $(\ell-)$ dominating set on G . The proof for EDS follows similarly as in the above case when a deleted edge (u, v) is not in Z (though an edge incident to v would be picked to become part of the dominating set instead of v itself). However if (u, v) is in the minimum edge $(\ell-)$ dominating set then it is possible that there are edges which are strictly (u, v) -dependent through only u or v and no single edge is within distance ℓ of both. In this case we add an edge adjacent to u and an edge adjacent to v to Z , which also increases Z 's size by one with the deletion of (u, v) . Thus if Z' is a minimum edge $(\ell-)$ dominating set on G' then $|Z'| \leq |Z| + \gamma$ and EDGE $(\ell-)$ DOMINATING SET is stable under edge deletion with constant $c' = 1$. \square

Lemma 4.14. $(\ell-)$ DOMINATING SET and EDGE $(\ell-)$ DOMINATING SET can be structurally lifted with respect to edge deletion with constants $c = 0$ and $c = 1$ respectively.

Proof. Given G and any set $X \subseteq E(G)$ with $|X| \leq \gamma$, let $G' = G[E \setminus X]$. A $(\ell-)$ dominating set in G' is also a $(\ell-)$ dominating set in G . Therefore, a solution S' in G' yields a solution S in G such that $\text{Cost}_{\text{DS}}(S') = \text{Cost}_{\text{DS}}(S)$.

An edge $(\ell-)$ dominating set Y' in G' may not be an edge $(\ell-)$ dominating set in G , as there may be edges in X which are not $(\ell-)$ dominated by Y' . However $Y' \cup X$ is an edge $(\ell-)$ dominating set in G and $|Y' \cup X| \leq |Y'| + |X|$. \square

Corollary 4.15. DOMINATING SET has an $O((1+\delta)r)$ -approximation for graphs $(\delta \cdot \text{OPT}(G))$ -close to degeneracy r via edge deletions.

Proof. We apply Theorem 4.1 using stability with constant $c' = 1$ (Lemma 4.13) and structural lifting with constant $c = 0$ (Lemma 4.14). We use our $(3, 3)$ -approximate editing algorithm (Section 5.3) and a known $O(r^2)$ -approximation algorithm for DS [59]. Thus $\alpha = \beta = 3$ and $\rho(\beta r) = \beta^2 r^2$, resulting in an approximation factor of $9(1 + 3\delta)r^2$. \square

Corollary 4.16. (ℓ) -DOMINATING SET and EDGE (ℓ) -DOMINATING SET have $(1 + O(\delta \log n \log \log n))$ -approximations for graphs $(\delta \cdot \text{OPT}(G))$ -close to treewidth w via edge deletions where $w \log w = O(\log_\ell n)$.

Proof. We apply Theorem 4.1 using stability with constant $c' = 1$ (Lemma 4.13) and structural lifting with constant $c = 0$ for DS and constant $c = 1$ for EDS (Lemma 4.14). For treewidth w , we use the $(O(\log n \log \log n), O(\log w))$ -approximate editing algorithm of Bansal et al. [3] and an exact algorithm for DS and EDS [9] given a tree-decomposition of width $O(w \log w)$ of the edited graph.

Thus $\alpha = O(\log n \log \log n)$ and $c' = 1$ for DS and $c' = c = 1$ for EDS, resulting in an approximation factor of $1 + O(\log n \log \log n)\delta$. Note that since the edited graph has treewidth $O(w \log w) = O(\log_\ell n)$, the exact algorithm runs in polynomial-time. \square

Lemma 4.17. The problem MAX-CUT is stable under edge deletion with constant $c' = 1$.

Proof. Given G and any set $X \subseteq E(G)$ with $|X| \leq \gamma$, let $G' = G[E \setminus X]$, and let Y be a maximum cut in G . Then, $Y' := Y \setminus X$ is a cut in G' of size at least $|Y| - |X|$; hence, $c' = 1$. \square

Lemma 4.18. MAX-CUT can be structurally lifted with respect to edge deletion with constant $c = 0$.

Proof. Given G and any set $X \subseteq E(G)$ with $|X| \leq \gamma$, let $G' = G[E \setminus X]$. A cut $Y \subseteq E(G')$ is trivially a valid cut in G and consequently $c = 0$. \square

Corollary 4.19. MAX-CUT has $(1 - O(\delta \log n \log \log n))$ -approximations for graphs $(\delta \cdot \text{OPT}(G))$ -close to treewidth w via edge deletions where $w \log w = O(\log n)$.

Proof. We apply Theorem 4.1 using stability with constant $c' = 1$ (Lemma 4.17) and structural lifting with constant $c = 0$ for MC (Lemma 4.18). For treewidth w , we use the $(O(\log n \log \log n), O(\log w))$ -approximate editing algorithm of Bansal et al. [3] and an exact algorithm for MC given a tree-decomposition of width $O(w \log w)$ of the edited graph.

Thus $\alpha = O(\log n \log \log n)$ and $c' = 1$ for MC, resulting in an approximation factor of $1 + O(\log n \log \log n)\delta$. Note that since the edited graph has treewidth $O(w \log w) = O(\log n)$, the exact algorithm runs in polynomial-time. \square

4.4 Vertex Deletion for Annotated Problems (Vertex* Deletion)

In this section, we show that several important variants of *annotated* DOMINATING SET (ADS) (which include their non-annotated variants as special cases) are closed under a relaxed version of vertex deletion, denoted by vertex* deletion, which is sufficient to apply the structural rounding framework. Given an instance of ANNOTATED ℓ -DOMINATING SET with input graph $G = (V, E)$ and a subset of vertices B , the resulting ADS instance (G', B') after deleting the set $X \subset V$ is defined as follows: $G' = (V \setminus X, E[V \setminus X])$ and $B' = B \setminus N_\ell[X]$ where $N_\ell[X]$ denotes the set of all vertices at distance at most ℓ from X in G .

Lemma 4.20. *For $\ell \geq 1$, ANNOTATED ℓ -DOMINATING SET is stable under vertex* deletion with $c' = 0$.*

Proof. Note that ANNOTATED ℓ -DOMINATING SET with $B = V$ reduces to ℓ -DOMINATING SET and in particular ℓ -DOMINATING SET is stable under vertex* deletion with constant $c' = 0$.

Let (G', B') denote the ADS instance after performing vertex* deletion with edit set X ; $G' = (V \setminus X, E[V \setminus X])$ and $B' = B \setminus N_\ell[X]$ where $N_\ell[X]$ denotes the set of all vertices at distance at most ℓ from X in G . Moreover, let $\text{OPT}(G, B)$ denote an optimal solution of $\text{ADS}(G, B)$. We show that $\text{OPT}(G, B) \setminus X$ is a feasible solution of $\text{ADS}(G', B')$. Since X ℓ -dominates $N_\ell[X]$, the set $B \setminus N_\ell[X]$ is ℓ -dominated by $\text{OPT}(G, B) \setminus X$; hence, $\text{OPT}(G, B) \setminus X$ is a feasible solution of $\text{ADS}(G', B')$. Thus $|\text{OPT}(G', B')| \leq |\text{OPT}(G, B) \setminus X| \leq |\text{OPT}(G, B)|$. \square

Lemma 4.21. *For $\ell \geq 1$, ANNOTATED ℓ -DOMINATING SET can be structurally lifted with respect to vertex* deletion with constant $c = 1$.*

Proof. Note that ANNOTATED ℓ -DOMINATING SET with $B = V$ reduces to ℓ -DOMINATING SET and in particular ℓ -DOMINATING SET can be structurally lifted with respect to vertex* deletion with constant $c = 1$.

Let $(G', B') = ((V \setminus X, E[V \setminus X]), B \setminus N_\ell[X])$ denote the ADS instance after performing vertex* deletion with edit set X on $\text{ADS}(G, B)$ and let $\text{OPT}(G', B')$ denote an optimal solution of $\text{ADS}(G', B')$ instance. Since the set X ℓ -dominates $N_\ell[X]$, $\text{OPT}(G', B') \cup X$ ℓ -dominates $B' \cup N_\ell[X] = B$. Hence, $|\text{OPT}(G, B)| \leq |\text{OPT}(G', B')| + |X|$. \square

Corollary 4.22. *ANNOTATED DOMINATING SET has an $O(r + \delta)$ -approximation for graphs $(\delta \cdot \text{OPT}(G))$ -close to degeneracy r via vertex deletion.*

Proof. We apply Theorem 4.1 using stability with constant $c' = 0$ (Lemma 4.20) and structural lifting with constant $c = 1$ (Lemma 4.21).

We use a $(O(1), O(1))$ -approximate editing algorithm (Section 5.1/ 5.2) and $O(r)$ -approximation algorithm for the problem of interest [4] in r -degenerate graphs. Note that although the algorithm of [4] is for DOMINATING SET, it can easily be modified to work for the annotated variant. Thus, $\alpha = O(1)$ and $c = 1$, resulting in an $O(r + \delta)$ -approximation algorithm. \square

Corollary 4.23. *ANNOTATED DOMINATING SET has an $O(1 + O(\delta \log^{1.5} n))$ -approximation for graphs $(\delta \cdot \text{OPT}(G))$ -close to treewidth w via vertex deletion where $w\sqrt{\log w} = O(\log_\ell n)$.*

Proof. We apply Theorem 4.1 using stability with constant $c' = 0$ (Lemma 4.20) and structural lifting with constant $c = 1$ (Lemma 4.21).

We use our $(O(\log^{1.5} n), O(\sqrt{\log w}))$ -approximate editing algorithm (Section 5.5) and an exact polynomial-time algorithm for the problem of interest [9] given the tree-decomposition of width $O(w\sqrt{\log w})$ of the edited graph. Note that the algorithm of [9] is presented for ℓ -DS; however, by slightly modifying the dynamic programming approach it works for the annotated version as well. Thus $\alpha = O(\log^{1.5} n)$ and $c = 1$, resulting in an approximation factor of $(1 + O(\log^{1.5} n)\delta)$. Moreover, since the edited graph has treewidth $O(w\sqrt{\log w}) = O(\log n)$, the exact algorithm runs in polynomial-time. \square

Smarter Vertex* Deletion. The idea of applying edit operations on annotated problems can also be used for non-annotated problems. More precisely, for several optimization problems that fail to satisfy the required conditions of the standard structural rounding under vertex deletion, we can still apply our structural rounding framework with a more careful choice of the subproblem

that we need to solve on the edited graph. An exemplary problem in this category is CONNECTED DOMINATING SET (CDS). Note that CONNECTED DOMINATING SET is not stable under vertex deletion and the standard structural rounding framework fails to work for this problem. Besides the stability issue, it is also non-trivial how to handle the connectivity constraint under vertex or edge deletions. However, in what follows we show that if we instead solve a *slightly different problem* (i.e. annotated variant of CONNECTED DOMINATING SET) on the edited graph, then we can guarantee an improved approximation factor for CDS on the graphs close to a structural class.

Let $G = (V, E)$ be an input graph that is $(\delta \cdot \text{OPT}(G))$ -close to the class \mathcal{C} and let $X \subset V$ be a set of vertices so that $G \setminus X \in \mathcal{C}$. For a subset of vertices X , $N_G(X)$ is defined to be the set of all neighbors of X excluding the set X itself; $N_G(X) := \{u \mid uv \in E(G), v \in X \text{ and } u \notin X\}$ ⁵. Let $G' = G[V \setminus X]$ be the resulting graph after removing the edit set X . The problem that we have to solve on G' is an *annotated* variant of CDS which is defined as follows:

ANNOTATED CONNECTED DOMINATING SET

Input: An undirected graph $G = (V, E)$, a subset of vertices $B \subset V$ and ℓ vertex-disjoint cliques $K_1 = (V_1, E_1), \dots, K_\ell = (V_\ell, E_\ell)$ where for each i , $V_i \subset V$.

Problem: Find a minimum size set of vertices $S \subseteq V$ s.t. S dominates all vertices in B and S induces a connected subgraph in $G \cup (\bigcup_{i \in [\ell]} K_i)$.

To specify the instance of ANNOTATED CONNECTED DOMINATING SET that we need to solve on the edited graph G' , we construct an auxiliary graph $\bar{G} = (N_G(X), \bar{E})$ as follows: $uv \in \bar{E}$ if there exists a uv -path in G whose intermediate vertices are all in X .

First, we show that CDS is stable under vertex* deletion with constant $c' = 0$: the size of an optimal solution of $\text{ACDS}(G', B', K_1, \dots, K_\ell)$ is not more than the size of an optimal solution of $\text{CDS}(G)$ where $\{K_1, \dots, K_\ell\}$ are the connected components of \bar{G} . Note that due to the transitivity of connectivity for each $i \in [\ell]$, K_i is a clique.

Lemma 4.24. *CONNECTED DOMINATING SET is stable under vertex* deletion with $c' = 0$.*

Proof. Let OPT be an optimal solution of $\text{CDS}(G)$. Here, we show that $\text{OPT} \setminus X$ is a feasible solution of $\text{ACDS}(G' = G[V \setminus X], B' = V \setminus N_G(X), K_1, \dots, K_\ell)$ where K_1, \dots, K_ℓ are connected components of \bar{G} as constructed above. This in particular implies that

$$\text{OPT}(G', B', K_1, \dots, K_\ell) \leq |\text{OPT} \setminus X| \leq |\text{OPT}| = \text{OPT}(G).$$

Since OPT dominates V , it is straightforward to verify that $\text{OPT} \setminus X$ dominates B' in G' . Next, we show that $\text{OPT} \setminus X$ is connected in G' when for each i , all edges between the vertices of K_i are added to G' . Suppose that there exists a pair of vertices $u, v \in \text{OPT} \setminus X$ that are not connected in G' . However, since OPT is connected, there exists a uv -path P_{uv} in OPT . If P_{uv} does not contain any vertices in X , then P_{uv} is contained in $\text{OPT} \setminus X$ as well and it is a contradiction. Now consider all occurrences of the vertices of X in P_{uv} . We show that each of them can be replaced by an edge in one of the K_i s: for each subpath $v_0, x_1, \dots, x_q, v_1$ of P_{uv} where $x_i \in X$ for all $i \in [q]$ and $v_0, v_1 \in N_G(X)$, $v_0 v_1$ belongs to the same connected component of \bar{G} . Hence, given P_{uv} , we can construct a path P'_{uv} in $G' \cup (\bigcup_{i \in [\ell]} K_i)$. Thus, $\text{OPT} \setminus X$ is a feasible solution of $\text{ACDS}(G', B', K_1, \dots, K_\ell)$. \square

Next, we show that a solution of the ANNOTATED CONNECTED DOMINATING SET instance we solve on the edited graph can be structurally lifted to a solution for CONNECTED DOMINATING SET on the original graph with constant $c = 3$.

⁵We drop the G in N_G when it is clear from the context.

Lemma 4.25. CONNECTED DOMINATING SET can be structurally lifted under vertex* deletion with constant $c = 3$.

Proof. Let OPT be an optimal solution of ACDS($G' = G[V \setminus X], B' = V \setminus N_G(X), K_1, \dots, K_\ell$) where K_1, \dots, K_ℓ are the connected components of \bar{G} as constructed above. Here, we show that $\text{OPT} \cup X \cup Y$ is a feasible solution of CDS(G) where Y is a subset of $V \setminus X$ such that $|Y| \leq 2|X|$. First, it is easy to see that since X dominates $N_G(X) \cup X$ in G , $\text{OPT} \cup X$ is a dominating set of G . Next, we show that in polynomial time we can find a subset of vertices Y of size at most $2|X|$ such that $\text{OPT} \cup X \cup Y$ is a connected dominating set in G .

Note that if the subgraph induced by the vertex set OPT on $G' \cup (\bigcup_{i \in [\ell]} K_i)$ contains an edge uv which is not in $E(G')$, the edge can be replaced by a uv -path in G whose intermediate vertices are all in X . Hence, we can replace all such edges in OPT by including a subset of vertices $X' \subseteq X$ and the set $\text{OPT} \cup X'$ remains connected in G . At this point, if $X = X'$, we are done: $\text{OPT} \cup X$ is a connected dominating set in G . Suppose this is not the case and let $X_1 := X \setminus X'$ and $Y_1 := N_G(X_1) \setminus N_G(X')$. Since G is connected, there exists a path from X_1 to $\text{OPT} \cup X'$. Moreover, we claim that there exists a path of length at most 4 from X_1 to $\text{OPT} \cup X'$. Recall that $\text{OPT} \cup X'$ dominates $V \setminus (X_1 \cup Y_1)$. Hence, the shortest path from X_1 to $\text{OPT} \cup X'$ has length at most 4. We add the vertices on the shortest path which are in $X \setminus X'$ to X' and the vertices in $V \setminus (X \cup \text{OPT} \cup Y)$ to Y , and update the sets X_1 and Y_1 accordingly. Thus we reduce the size of X_1 and as we repeat this process it eventually becomes zero. At this point $X = X'$ and $\text{OPT} \cup X \cup Y$ is a connected dominating set in G . Since, we pick up at most three vertices per each $x \in X_1$ and at least one is in X , the set $X \cup Y$ has size at most $3|X|$. \square

Corollary 4.26. CONNECTED DOMINATING SET has $O(1 + O(\delta \log^{1.5} n))$ -approximation for graphs $(\delta \cdot \text{OPT}(G))$ -close to treewidth w via vertex deletion where w is a fixed constant.

Proof. We apply Theorem 4.1 using stability with constant $c' = 0$ (Lemma 4.24) and structural lifting with constant $c = 3$ (Lemma 4.25).

We use our $(O(\log^{1.5} n), O(\sqrt{\log w}))$ -approximate editing algorithm (Section 5.5) and an exact polynomial-time algorithm for ACDS given the tree-decomposition of width $O(w\sqrt{\log w})$ of the edited graph. The FPT algorithm modifies the $w^{O(w)} \cdot n^{O(1)}$ dynamic-programming approach of DS such that it incorporates the annotated sets and cliques K_1, \dots, K_ℓ which then runs in $(w + \ell)^{O(w)} \cdot n^{O(1)} = n^{O(w)}$. Thus $w = O(1)$, $\alpha = O(\log^{1.5} n)$ and $c = 3$, resulting in an algorithm that runs in polynomial time and constructs a $(1 + O(\log^{1.5} n)\delta)$ -approximate solution. \square

Although we do not present any editing algorithms for edge contractions, we point out that such an editing algorithm would enable our framework to apply to additional problems such as (WEIGHTED) TSP TOUR (which is closed under edge contractions and can be structurally lifted with constant $c = 2$ [21]), and to apply more efficiently to other problems such as DOMINATING SET (reducing c' from 1 to 0).

5 Editing Algorithms

5.1 Degeneracy: Density-Based Bicriteria Approximation

In this section we prove the following:

Theorem 5.1. r -DE-V has a $\left(\frac{4m - \beta rn}{m - rn}, \beta\right)$ -approximation algorithm.

Observe that this yields a $(4, 4)$ -approximation when $\beta = 4$. The algorithm is defined in Algorithm 1, and the analysis is based on the local ratio theorem from Bar-Yehuda et al. [5].

5.1.1 Analysis overview and the local ratio theorem

Fundamentally, the local ratio theorem [5] is machinery for showing that “good enough” local choices accumulate into a global approximation bound. This bookkeeping is done by maintaining *weight vectors* that encode the choices made. The local ratio theorem applies to optimization problems of the following form: given a weight vector $w \in \mathbb{R}^n$ and a set of feasibility constraints \mathcal{C} , find a solution vector $x \in \mathbb{R}^n$ satisfying the constraints \mathcal{C} and minimizing $w^T x$ (for maximization problems see [5]). We say a solution x to such a problem is **α -approximate with respect to w** if $w^T x \leq \alpha \cdot \min_{z \in \mathcal{C}} (w^T z)$.

Theorem 5.2 (Local Ratio Theorem [5]). *Let \mathcal{C} be a set of feasibility constraints on vectors in \mathbb{R}^n . Let $w, w_1, w_2 \in \mathbb{R}^n$ be such that $w = w_1 + w_2$. Let $x \in \mathbb{R}^n$ be a feasible solution (with respect to \mathcal{C}) that is α -approximate with respect to w_1 , and with respect to w_2 . Then x is α -approximate with respect to w as well.*

In our case, an instance of (βr) -DEGENERATE VERTEX DELETION (abbreviated (βr) -DE-V) is represented with (G, w, r, β) , where G is the graph, w is a weight vector on the vertices (where w is the all-ones vector, $\vec{1}$, when G is unweighted), r is our target degeneracy, and β is a multiplicative error on the target degeneracy. Our bicriteria approximation algorithm will yield an edit set to a (βr) -degenerate graph, using at most $\alpha \cdot \text{OPT}_{(\beta r)\text{-DE-V}}(G, w, r, \beta)$ edits. This (weighted) cost function is encoded as an input vector of vertex weights w , which is evaluated with an indicator function \mathcal{I}_X on a feasible solution X , such that the objective is to minimize $w^T \mathcal{I}_X$. Note that while the local ratio theorem can allow all feasible solutions, we require *minimal* feasible solutions for stronger structural guarantees.

Algorithm 1 Approximation for r -DEGENERATE VERTEX DELETION

```

1: procedure LOCALRATIORECURSION(Graph  $G$ , weights  $w$ , target degeneracy  $r$ , error  $\beta$ )
2:   if  $V(G) = \emptyset$  then
3:     return  $\emptyset$ .
4:   else if  $\exists v \in V(G)$  where  $\deg_G(v) \leq \beta r$  then
5:     return LOCALRATIORECURSION( $G \setminus \{v\}$ ,  $w$ ,  $r$ ,  $\beta$ )
6:   else if  $\exists v \in V(G)$  where  $w(v) = 0$  then
7:      $X \leftarrow$  LOCALRATIORECURSION( $G \setminus \{v\}$ ,  $w$ ,  $r$ ,  $\beta$ )
8:     if  $G \setminus X$  has degeneracy  $\beta r$  then
9:       return  $X$ .
10:    else
11:      return MINIMALSOLUTION( $G, X \cup \{v\}$ ,  $r$ ,  $\beta$ ).
12:    end if
13:   else
14:     Let  $\varepsilon := \min_{v \in V(G)} \frac{w(v)}{\deg_G(v)}$ .
15:     Define  $w_1(u) := \varepsilon \cdot \deg_G(u)$  for all  $u \in V$ .
16:     Define  $w_2 := w - w_1$ .
17:     return LOCALRATIORECURSION( $G, w_2, r, \beta$ ).
18:   end if
19: end procedure

```

To utilize the local ratio theorem, our strategy is to define a recursive function that decomposes the weight vector into $w = w_1 + w_2$ and then recurses on (G, w_2, r, β) . By showing that the choices made in this recursive function lead to an (α, β) -approximation for the instances (G, w_1, r, β) and

(G, w_2, r, β) , by the local ratio theorem, these choices also sum to an (α, β) -approximation for (G, w, r, β) .

As outlined in [5, Section 5.2], the standard algorithm template for this recursive method handles the following cases: if a zero-cost minimal solution can be found, output this optimal solution, else if the problem contains a zero-cost element, do a problem size reduction, and otherwise do a weight decomposition.

Algorithm 2 Subroutine for guaranteeing minimal solutions

```

1: procedure MINIMALSOLUTION(Graph  $G$ , edit set  $X$ , target degeneracy  $r$ , error  $\beta$ )
2:   for vertex  $v \in V(G)$  do
3:     if  $G \setminus (X \setminus \{v\})$  has degeneracy  $\beta r$  then
4:       return MINIMALSOLUTION( $G, X \setminus \{v\}, r, \beta$ ).
5:     end if
6:   end for
7:   return  $X$ .
8: end procedure

```

Algorithm 1 follows this structure: Lines 2-3 are the first case, Lines 4-12 are the second case, and Lines 13-18 are the third case. The first two cases are typically straightforward, and the crucial step is the weight decomposition of $w = w_1 + w_2$. Note that the first case guarantees that all vertices in G have degree at least $\beta r + 1$ before a weight decomposition is executed, so we may assume WLOG that the original input graph also has minimum degree $\beta r + 1$.

In the following subsections we show that Algorithm 1 returns a minimal, feasible solution (Lemma 5.3), that the algorithm returns an (α, β) -approximate solution with respect to w_1 (Theorem 5.4), and finally that the algorithm returns an (α, β) -approximate solution with respect to w (Theorem 5.1).

5.1.2 $\left(\frac{4m-\beta rn}{m-rn}, \beta\right)$ -approximation for vertex deletion

Lemma 5.3. *Algorithm 1 returns minimal, feasible solutions for (βr) -DE-V.*

Proof. We proceed by induction on the number of recursive calls. In the base case, only Lines 2-3 will execute, and the empty set is trivially a minimal, feasible solution. In the inductive step, we show feasibility by constructing the degeneracy ordering. We consider each of the three branching cases not covered by the base case:

- Lines 4-5: Given an instance (G, w, r, β) , if a vertex v has degree at most βr , add v to the degeneracy ordering and remove it from the graph. By the induction hypothesis, the algorithm will return a minimal, feasible solution $X_{\beta r}$ for $(G - \{v\}, w, r, \beta)$. By definition, v has at most βr neighbors later in the ordering (e.g. neighbors in $G - \{v\}$), so the returned $X_{\beta r}$ is still a feasible, minimal solution.
- Lines 6-12: Given an instance (G, w, r, β) , if a vertex v has weight 0, remove v from the graph. By the induction hypothesis, the algorithm will return a minimal, feasible solution $X_{\beta r}$ for $(G - \{v\}, w, r, \beta)$. If $X_{\beta r}$ is a feasible solution on the instance (G, w, r, β) , then $X_{\beta r}$ will be returned as the minimal, feasible solution for this instance. Otherwise the solution $X_{\beta r} \cup \{v\}$ is feasible, and can be made minimal with a straightforward greedy subroutine (Algorithm 2).
- Lines 13-18: In this case, no modifications are made to the graph, therefore the recursive call's minimal, feasible solution $X_{\beta r}$ remains both minimal and feasible.

In all cases, a minimal, feasible solution is returned. \square

We now show that a minimal, feasible solution is (α, β) -approximate with respect to the instance defined by weight function w_1 :

Theorem 5.4. *Any minimal, feasible solution $X_{\beta r}$ is a $\left(\frac{4m-\beta rn}{m-rn}, \beta\right)$ -approximation to the instance (G, w_1, r, β) .*

Given a minimal, feasible solution $X_{\beta r}$, note that $w_1^T \mathcal{I}_{X_{\beta r}} = \varepsilon \sum_{v \in X_{\beta r}} \deg_G(v)$. Therefore it suffices to show that $b \leq \sum_{v \in X_r} \deg_G(v)$ and $\sum_{v \in X_{\beta r}} \deg_G(v) \leq \alpha b$, for some bound b , any minimal, feasible edit set X_r to degeneracy r , and any minimal, feasible edit set $X_{\beta r}$ to degeneracy βr . We prove these two bounds for $b = m - rn$ in Lemmas 5.5 and 5.8, respectively.

Lemma 5.5. *For any minimal feasible solution X_r for editing to degeneracy r ,*

$$m - rn \leq \sum_{v \in X_r} \deg_G(v).$$

Proof. Since $G \setminus X_r$ has degeneracy r , it has at most rn edges, so at least $m - rn$ edges were deleted. Each deleted edge had at least one endpoint in X_r , therefore $m - rn \leq \sum_{v \in X_r} \deg_G(v)$. \square

Before proving the upper bound, we define some notation. Let $X_{\beta r}$ be a minimal, feasible solution to (βr) -DE-V and let $Y = V(G) \setminus X_{\beta r}$ be the vertices in the (βr) -degenerate graph. Denote by m_X , m_Y , and m_{XY} the number of edges with both endpoints in $X_{\beta r}$, both endpoints in Y , and one endpoint in each set, respectively. We begin by bounding m_{XY} :

Lemma 5.6. *For any $X_{\beta r}$, it holds that $m_{XY} \leq 2m_Y + 2m_{XY} - \beta r|Y|$.*

Proof. Recall that we may assume WLOG that every vertex in G has degree at least $\beta r + 1$. Therefore $\beta r|Y| \leq \sum_{v \in Y} \deg_G(v) \leq 2m_Y + m_{XY}$, and so $m_{XY} \leq 2m_Y + 2m_{XY} - \beta r|Y|$. \square

Corollary 5.7. *For any $X_{\beta r}$, it holds that $-\beta r|X_{\beta r}| \geq -2m_Y - 2m_{XY} + \beta r|Y|$.*

Proof. Because $X_{\beta r}$ is minimal, every vertex in $X_{\beta r}$ will induce a $(\beta r + 1)$ -core with vertices in Y if not removed. Therefore each such vertex has at least $(\beta r + 1)$ -neighbors in Y , and $\beta r|X_{\beta r}| \leq m_{XY}$. Substituting into Lemma 5.6, we find that $-\beta r|X_{\beta r}| \geq -2m_Y - 2m_{XY} + \beta r|Y|$. \square

We now prove the upper bound:

Lemma 5.8. *For any minimal, feasible solution $X_{\beta r}$ to (βr) -DE-V,*

$$\sum_{v \in X_{\beta r}} \deg_G(v) \leq 4m - \beta rn.$$

Proof. By using substitutions from Lemmas 5.6 and Corollary 5.7, we know that

$$\begin{aligned} \sum_{v \in X_{\beta r}} \deg_G(v) &= 2m_X + m_{XY} \\ &\leq 2m_X + 2m_Y + 2m_{XY} - \beta r|Y| \\ &= 2m - \beta r|Y| \\ &= 2m + 2m_Y + 2m_{XY} - 2m_Y - 2m_{XY} + \beta r|Y| - 2\beta r|Y| \\ &\leq 2m + 2m_Y + 2m_{XY} - \beta r|X_{\beta r}| - 2\beta r|Y| \\ &\leq 4m - \beta rn. \end{aligned}$$

\square

Proof of Theorem 5.4. Let $X_{\beta r}$ be any minimal, feasible solution for editing to a graph of degeneracy βr . By definition of w_1 in Algorithm 1, it holds that $w_1^T \mathcal{I}_{X_{\beta r}} = \varepsilon \sum_{v \in X_{\beta r}} \deg_G(v)$, and because ε is a constant computed independently of the optimal solution, it suffices to show that $\sum_{v \in X_{\beta r}} \deg_G(v)$ has an α -approximation.

By Lemma 5.5, any minimal, feasible edit set to a degeneracy- r graph has a degree sum of at least $m - rn$. If an edit set is allowed to leave a degeneracy- (βr) graph, then by Lemma 5.8, at most $4m - \beta rn$ degrees are added to the degree sum of $X_{\beta r}$. Therefore $X_{\beta r}$ is $\left(\frac{4m - \beta rn}{m - rn}, \beta\right)$ -approximate with respect to (G, w_1, r, β) . \square

We now prove the main result stated at the beginning of this section, Theorem 5.1.

Proof. For clarity, let $\alpha := \left(\frac{4m - \beta rn}{m - rn}\right)$; we prove that Algorithm 1 is an (α, β) -approximation. We proceed by induction on the number of recursive calls to Algorithm 1. In the base case (Lines 2-3), the solution returned is the empty set, which is trivially optimal. In the induction step, we examine the three recursive calls:

- Lines 4-5: Given an instance (G, w, r, β) , if a vertex v has degree at most βr , add v to the degeneracy ordering and remove it from the graph. By the induction hypothesis, the algorithm will return an (α, β) -approximate solution $X_{\beta r}$ for $(G - \{v\}, w, r, \beta)$. Since v will not be added to $X_{\beta r}$, then $X_{\beta r}$ is also an (α, β) -approximation for (G, w, r, β) .
- Line 6-12: Given an instance (G, w, r, β) , if a vertex v has weight 0, remove v from the graph. By the induction hypothesis, the algorithm returns an (α, β) -approximate solution $X_{\beta r}$ for $(G - \{v\}, w, r, \beta)$. Regardless of whether v is added to $X_{\beta r}$ or not, it contributes exactly zero to the cost of the solution, therefore an (α, β) -approximation is returned.
- Line 13-18: In this case, the weight vector is decomposed into w_1 and $w_2 = w - w_1$. By induction, the algorithm will return an (α, β) -approximate solution $X_{\beta r}$ for $(G, w - w_1, r, \beta)$. By Theorem 5.4, $w_1^T \mathcal{I}_{X_{\beta r}}$ is also (α, β) -approximate. Therefore, by Theorem 5.2, $w^T \mathcal{I}_{X_{\beta r}}$ must be (α, β) -approximate.

\square

5.2 Degeneracy: LP-based Bicriteria Approximation

In this section, we design a bicriteria approximation for the problem of minimizing the number of required edits (edge/vertex deletions) to the family of r -degenerate graphs. Consider an instance of r -DEGENERATE EDGE DELETION(G, r) and let OPT denote an optimal solution. The algorithm we describe here works even when the input graph is *weighted* (both vertices and edges are weighted) and the goal is to minimize the total weight of the edit set.

Our approach is based on Lemma 3.2 which we restate here for convenience.

Lemma 5.9. *A graph $G = (V, E)$ is $(2r)$ -degenerate if there exists an orientation of the edges in E such that the out-degree of each vertex v is at most r .*

5.2.1 (6, 6)-approximation for vertex deletion

In what follows we formulate an LP-relaxation for the problem of minimizing the number of required vertex deletions to the family of r -degenerate graphs. For each edge $uv \in E$, x_{uv} variable denotes the orientation of uv ; $x_{\vec{uv}} = 1$, $x_{\vec{vu}} = 0$ if uv is oriented from u to v and $x_{\vec{vu}} = 1$, $x_{\vec{uv}} = 0$ otherwise.

Moreover, for each vertex $v \in V$ we define y_v to denote whether v is part of the edit set X ($y_v = 1$ if $v \in X$ and zero otherwise).

DEGENVERTEXEDIT-LP

Input: $G = (V, E), w, r$

$$\begin{array}{ll}
 \text{Minimize} & \sum_{v \in V} y_v w_v \\
 \text{s.t.} & x_{\vec{vu}} + x_{\vec{uv}} \geq 1 - y_u - y_v \quad \forall uv \in E \\
 & \sum_{u \in N(v)} x_{\vec{vu}} \leq r \quad \forall v \in V \\
 & x_{\vec{uv}} \geq 0 \quad \forall uv \in E
 \end{array}$$

The first set of constraints in the LP-relaxation DEGENVERTEXEDIT-LP guarantees that for each edge uv whose none of its endpoints is in X , it is oriented either from v to u or from u to v . The third set of the constraints ensure that for all $v \in V$, $\deg^+(v) \leq r$. Note that if $v \in X$ and thus $y_v = 1$, then WLOG we can assume that both $x_{\vec{uv}}$ and $x_{\vec{vu}}$ are set to zero.

Lemma 5.10. *DEGENVERTEXEDIT-LP(G, w, r) is a valid LP-relaxation of r -DE-V(G, w).*

Proof. Let X be a feasible edit set of r -DE-V(G, w). Let D be an r -degenerate ordering of $V \setminus X$. We define vectors (x, y) corresponding to X as follows: for each $v \in V$, $y(v) = 0$ if $v \in X$ and zero otherwise. Moreover, $x_{\vec{uv}} = 1$ if $u, v \in V \setminus X$ and u comes before v in the ordering D ; otherwise, $x_{\vec{uv}}$ is set to zero.

Next, we show that the constructed solution (x, y) satisfies all constraints in DEGENVERTEXEDIT-LP. Since x only obtains non-negative values, for the first set of constraints we can only consider the set of survived edges after removing set X , $E[V \setminus X]$. For these edges, since one of u and v comes first in D , exactly one of $x_{\vec{uv}}, x_{\vec{vu}}$ is one and the constraint is satisfied. Lastly, since D is an r -degenerate ordering of $V \setminus X$, for each vertex $v \in V \setminus X$, the out-degree is at most r . Moreover, for each $v \in X$, the LHS in the second set of constraints is zero. \square

Similarly to our approach for r -DEGENERATE EDGE DELETION, first we find an optimal solution (x, y) of DEGENVERTEXEDIT-LP in polynomial time.

Rounding scheme. We prove that the following rounding scheme of DEGENVERTEXEDIT-LP gives a $(\frac{1}{\varepsilon}, \frac{4}{1-2\varepsilon})$ -bicriteria approximation for r -DE-V.

$$\hat{y}_v = \begin{cases} 1 & \text{if } y_v \geq \varepsilon, \\ 0 & \text{otherwise.} \end{cases} \quad (4)$$

$$\hat{x}_{uv} = \begin{cases} 1 & \text{if } x_{uv} \geq (1 - 2\varepsilon)/2, \\ 0 & \text{otherwise.} \end{cases} \quad (5)$$

Lemma 5.11. *If (x, y) is an optimal solution to DEGENVERTEXEDIT-LP, then (\hat{x}, \hat{y}) as given by Equations 4 and 5 is an integral $(\frac{1}{\varepsilon}, \frac{2}{1-2\varepsilon})$ -bicriteria approximate solution of DEGENVERTEXEDIT-LP(G, w, r).*

Proof. First we show that (\hat{x}, \hat{y}) satisfies the first set of constraints: for each $uv \in E$, $\hat{x}_{\vec{vu}} + \hat{x}_{\vec{uv}} \geq 1 - \hat{y}_v - \hat{y}_u$. Note that if either \hat{y}_v or \hat{y}_u is one then the constraint trivially holds. Hence, we assume that both \hat{y}_v and \hat{y}_u are zero. By Equation (4), this implies that both y_v and y_u have value less than ε . Hence, by feasibility of (x, y) ,

$$x_{\vec{vu}} + x_{\vec{uv}} \geq 1 - y_v - y_u \geq 1 - 2\varepsilon,$$

and in particular, $\max(x_{\vec{vu}}, x_{\vec{uv}}) \geq \frac{1-2\varepsilon}{2}$. Then, by Equation (5), $\max(\hat{x}_{\vec{uv}}, \hat{x}_{\vec{vu}}) = 1$ and the constraint is satisfied: $\hat{x}_{uv} + \hat{x}_{vu} \geq 1 \geq 1 - \hat{y}_v - \hat{y}_u$. Note that if both of \hat{x}_{uv} and \hat{x}_{vu} are set to one, we can arbitrarily set one of them to zero.

Moreover, since for each arc \vec{uv} , $\hat{x}_{\vec{uv}} \leq \frac{2}{1-2\varepsilon} \cdot x_{\vec{uv}}$, for each $v \in V$:

$$\sum_{u \in N(v)} \hat{x}_{\vec{vu}} \leq \frac{2}{1-2\varepsilon} \cdot \sum_{u \in N(v)} x_{\vec{vu}} \leq \frac{2r}{1-2\varepsilon},$$

where the first inequality follows from Equation (5) and the second from the feasibility of (x, z) .

Finally, since for each $v \in V$, $\hat{y}_v \leq y_v/\varepsilon$, the cost of the rounded solution (\hat{x}, \hat{y}) is at most

$$\sum_{u \in V} \hat{y}_v w_v \leq \frac{1}{\varepsilon} \cdot \sum_{u \in V} y_v w_v \leq \text{OPT}_{r\text{-DE-V}}(G, w, r)/\varepsilon,$$

where the first inequality follows from Equation (4) and the second directly from the optimality of (x, y) . Hence, (\hat{x}, \hat{y}) is an integral $(\frac{1}{\varepsilon}, \frac{2}{1-2\varepsilon})$ -bicriteria approximate solution of $\text{DEGENVERTEXEDIT-LP}(G, w, r)$. \square

Note that, the integral solution (\hat{x}, \hat{y}) specifies an edit set $X := \{v \in V | \hat{y}(v) = 1\}$ and orientation of edges $D := \{\vec{uv} | x_{\vec{uv}} = 1\}$ such that for each $v \in V \setminus X$, $\deg^+(v) \leq \frac{2r}{1-2\varepsilon}$. Hence, together with Lemma 5.9, we have the following result.

Corollary 5.12. *There exists a $(\frac{1}{\varepsilon}, \frac{4}{1-2\varepsilon})$ -bicriteria approximation for $r\text{-DE-V}$.*

In particular, by setting $\varepsilon = 1/6$, there exists a $(6, 6)$ -bicriteria approximation algorithm for the $r\text{-DEGENERATE VERTEX DELETION}$ problem.

5.3 (5, 5)-approximation for edge deletion

In what follows we formulate an LP-relaxation for the problem of minimizing the number of required edge edits (deletions) to the family of r -degenerate graphs. For each edge $uv \in E$, x variables denote the orientation of uv ; $x_{\vec{uv}} = 1$, $x_{\vec{vu}} = 0$ if uv is oriented from u to v and $x_{\vec{vu}} = 1$, $x_{\vec{uv}} = 0$ if e is oriented from v to u . Moreover, for each uv we define z_{uv} to denote whether the edge uv is part of the edit set X ($z_{uv} = 1$ if the edge $uv \in X$ and zero otherwise).

— DEGENEDGEEDIT-LP —

Input: $G = (V, E), w, r$

$$\begin{array}{ll} \text{Minimize} & \sum_{uv \in E} z_{uv} w_{uv} \\ \text{s.t.} & x_{\vec{vu}} + x_{\vec{uv}} \geq 1 - z_{uv} \quad \forall uv \in E \\ & \sum_{u \in N(v)} x_{\vec{vu}} \leq r \quad \forall v \in V \\ & x_{\vec{uv}} \geq 0 \quad \forall uv \in V \times V \end{array}$$

The first set of constraints in the LP-relaxation DEGENEDGEEDIT-LP guarantee that for each edge $uv \notin X$, it is oriented either from v to u or from u to v . The second set of the constraints ensure that for all $v \in V$, $\deg^+(v) \leq r$. Note that if an edge $uv \in X$ and thus $z_{uv} = 1$, then WLOG we can assume that both $x_{\vec{uv}}$ and $x_{\vec{vu}}$ are set to zero.

Lemma 5.13. DEGENEDGEEDIT-LP(G, w, r) is a valid LP-relaxation of r -DE-E(G, w).

Next, we propose a *two-phase* rounding scheme for the DEGENEDGEEDIT-LP.

First phase. Let (x, z) be an optimal solution of DEGENEDGEEDIT-LP. Note that since the DEGENEDGEEDIT-LP has polynomial size, we can find its optimal solution efficiently. Consider the following *semi-integral* solution (x, \hat{z}) of DEGENEDGEEDIT-LP:

$$\hat{z}_{uv} = \begin{cases} 1 & \text{if } z_{uv} \geq \varepsilon, \\ 0 & \text{otherwise.} \end{cases} \quad (6)$$

Claim 5.14. $(\frac{x}{1-\varepsilon}, \hat{z})$ as given by Equation (6) is a $(\frac{1}{\varepsilon}, \frac{1}{1-\varepsilon})$ -bicriteria approximate solution of DEGENEDGEEDIT-LP(G, w, r).

Proof. First, we show that $(\frac{1}{1-\varepsilon}x, \hat{z})$ satisfies the first set of constraints. For each edge uv ,

$$\frac{x_{\vec{uv}}}{1-\varepsilon} + \frac{x_{\vec{vu}}}{1-\varepsilon} = \frac{1}{1-\varepsilon}(x_{\vec{uv}} + x_{\vec{vu}}) \geq \frac{1}{1-\varepsilon}(1 - z_{uv}) \geq 1 - \hat{z}_{uv},$$

where the first inequality follows from the feasibility of (x, z) and the second inequality follows from Equation (6). Moreover, it is straightforward to check that as we multiply each x_{vu} by a factor of $1/(1-\varepsilon)$, the second set of constraints are off by the same factor; that is, $\forall v \in V, \sum_{u \in V} x_{\vec{vu}}/(1-\varepsilon) \leq r/(1-\varepsilon)$. Finally, since for each edge uv , $\hat{z}_{uv} \leq z_{uv}/\varepsilon$, the cost of the edit set increases by at most a factor of $1/\varepsilon$; that is, $\sum_{uv \in E} \hat{z}_{uv} w_{uv} \leq \frac{1}{\varepsilon} \sum_{uv \in E} z_{uv} w_{uv}$. \square

Second phase. Next, we prune the fractional solution further to get an *integral* approximate *nearly feasible* solution of DEGENEDGEEDIT-LP. Let \hat{x} denote the orientation of the surviving edges (edges uv such that $\hat{z}_{uv} = 0$) given by:

$$\hat{x}_{\vec{uv}} = \begin{cases} 1 & \text{if } x_{\vec{uv}} \geq (1-\varepsilon)/2, \\ 0 & \text{otherwise.} \end{cases} \quad (7)$$

We say an orientation is *valid* if each surviving edge (u, v) is oriented from u to v or v to u .

Lemma 5.15. \hat{x} as given by Equation (7) is a valid orientation of the set of surviving edges.

Proof. We need to show that for each $uv \in E$ with $\hat{z}_{uv} = 0$ at least one of $\hat{x}_{\vec{uv}}$ or $\hat{x}_{\vec{vu}}$ is one. Note that if both are one, we can arbitrarily set one of them to zero.

For an edge uv , by Equation (6), $\hat{z}_{uv} = 0$ iff $z_{uv} \leq \varepsilon$. Then, using the fact that (x, z) is a feasible solution of DEGENEDGEEDIT-LP, $x_{\vec{uv}} + x_{\vec{vu}} \geq 1 - z_{uv} \geq 1 - \varepsilon$. Hence, $\max(x_{\vec{uv}}, x_{\vec{vu}}) \geq (1-\varepsilon)/2$ which implies that $\max(\hat{x}_{\vec{uv}}, \hat{x}_{\vec{vu}}) = 1$. Hence, for any surviving edge uv , at least one of $\hat{x}_{\vec{uv}}$ or $\hat{x}_{\vec{vu}}$ will be set to one. \square

Lemma 5.16. (\hat{x}, \hat{z}) as given by Equations 6 and 7 is an integral $(\frac{1}{\varepsilon}, \frac{2}{1-\varepsilon})$ -bicriteria approximate solution of DEGENEDGEEDIT-LP(G, w, r).

Proof. As we showed in Lemma 5.15, \hat{x} is a valid orientation of the surviving edges with respect to \hat{z} . Moreover, by Equation (7), for each $uv \in E$, $\hat{x}_{\vec{uv}} \leq 2x_{\vec{uv}}/(1 - \varepsilon)$. Hence, for each vertex $v \in V$, $\deg^+(v) \leq 2r/(1 - \varepsilon)$. Finally, as we proved in Claim 5.14, the total weight of the edit set defined by \hat{z} is at most $\frac{1}{\varepsilon}$ times the total weight of the optimal solution (x, z) . \square

Hence, together with Lemma 3.2, we have the following result.

Corollary 5.17. *There exists a $(\frac{1}{\varepsilon}, \frac{4}{1-\varepsilon})$ -bicriteria approximation algorithm for r -DE-E.*

In particular, by setting $\varepsilon = 1/5$, there exists a $(5, 5)$ -bicriteria approximation algorithm for the r -DEGENERATE EDGE DELETION problem.

We note that our approach also works in the general setting when both vertices and edges are weighted, and we consider an edit operation which includes both vertex and edge deletion.

5.3.1 Integrality gap of DEGENEDGEEDIT-LP and DEGENVERTEXEDIT-LP

A natural open question is if we can obtain “purely multiplicative” approximation guarantees for r -DE-E and r -DE-V via LP-based approaches. In this section, we show that the existing LP-relaxation of editing to bounded degeneracy cannot achieve $o(n)$ -approximation. These results are particularly important because they show that the best we can hope for are bicriteria approximations.

Theorem 5.18. *The integrality gap of DEGENEDGEEDIT-LP is $\Omega(n)$.*

Proof. Consider an instance of r -DE-E(G) where G is an unweighted complete graph of size $2n$ and $r = n - 2$. First, we show that DEGENEDGEEDIT-LP(G, r) admits a fractional solution of cost/size $O(n)$ and then we show that the size of any feasible edit set of r -DE-E(G) is $\Omega(n^2)$.

Consider the following fractional solution of DEGENEDGEEDIT-LP(G, r): for all $uv \in V \times V$ and $u \neq v$, $x_{\vec{uv}} = 1/2 - 1/n$ and for all edges $uv \in E$, $z_{uv} = 2/n$. Note that x and z satisfy the first set of constraints in DEGENEDGEEDIT-LP(G, r):

$$\forall uv \in E, \quad x_{\vec{uv}} + x_{\vec{vu}} = 1 - 2/n = 1 - z_{uv}.$$

Moreover, x satisfies the second set of the constraints in DEGENEDGEEDIT-LP(G, r)

$$\forall v \in V, \quad \sum_{u \in V} x_{\vec{vu}} = (2n - 1)(1/2 - 1/n) < n - 2.$$

Finally, $\text{Cost}(x, z) = \sum_{uv \in E} z_{uv} = n(2n - 1) \cdot (2/n) = 4n - 2$ which implies that the cost of an optimal solution of DEGENEDGEEDIT-LP(G, r) is $O(n)$.

Next, we show that any integral solution of r -DE-E(G, r) has size $\Omega(n^2)$. Let X be a solution of r -DE-E(G, r). Then, there exists an ordering of the vertices in G , v_1, \dots, v_{2n} such that $\deg(v_i)$ in $G[v_i, \dots, v_{2n}]$ is at most $r \leq n - 2$. This implies that for $i \leq n - 2$, $|\delta(v_i) \cap X| \geq n + 2 - i$, where $\delta(v)$ denotes the set of edges incident to a vertex v . Thus,

$$|X| \geq \frac{1}{2} \sum_{i \leq n-2} |\delta(v_i) \cap X| \geq \frac{1}{2} \sum_{i \leq n-2} n + 2 - i \geq \frac{1}{2}(n^2 - 4 - \frac{(n-2)(n-3)}{2}) \geq n^2/4.$$

Hence, the integrality gap of DEGENEDGEEDIT-LP is $\Omega(n)$. \square

Theorem 5.19. *The integrality gap of DEGENVERTEXEDIT-LP is $\Omega(n)$.*

Proof. Consider an instance of r -DE-V(G) where G is an unweighted complete graph of size $2n$ and $r = n - 2$. First, we show that DEGENVERTEXEDIT-LP(G, r) admits a constant size fractional solution and then we show that the size of any feasible edit set of r -DE-E(G) is $\Omega(n)$.

Consider the following fractional solution of DEGENVERTEXEDIT-LP(G, r): for each $uv \in V^2$ and $u \neq v$, $x_{\overrightarrow{uv}} = 1/2 - 1/n$ and for each vertex $v \in V$, $z_v = 1/n$. First, we show that x and z satisfy the first set of constraints in DEGENVERTEXEDIT-LP(G, r):

$$\forall uv \in E, \quad x_{\overrightarrow{uv}} + x_{\overrightarrow{vu}} = 1 - 2/n = 1 - z_u - z_v.$$

Moreover, x satisfies the second set of the constraints in DEGENVERTEXEDIT-LP(G, r)

$$\forall v \in V, \quad \sum_{u \in V} x_{\overrightarrow{vu}} = (2n - 1)(1/2 - 1/n) < n - 2.$$

Finally, $\text{Cost}(x, z) = \sum_{uv \in E} z_{uv} = 2n \cdot (1/n) = 2$ which implies that the cost of an optimal solution of DEGENVERTEXEDIT-LP(G, r) is at most 2.

Next, we show that any integral solution of r -DE-V(G, r) has size $\Omega(n)$. Let X be a solution of r -DE-E(G, r). Since $G \setminus X$ is a complete graph of size $2n - |X|$, in order to get degeneracy $n - 2$, $|X| \geq n + 2$.

Hence, the integrality gap of DEGENVERTEXEDIT-LP is $\Omega(n)$. \square

5.4 Degeneracy: $O(\log n)$ Greedy Approximation

In this section, we give a polytime $O(\log n)$ -approximation for reducing the degeneracy of a graph by one using either vertex deletions or edge deletions. More specifically, given a graph $G = (V, E)$ with degeneracy r , we produce an edit set X such that $G' = G \setminus X$ has degeneracy $r - 1$ and $|X|$ is at most $O(\log |V|)$ times the size of an optimal edit set. Note that this complements an $O(\log \frac{n}{r})$ -approximation hardness result for the same problem.

In general, the algorithm works by computing a vertex ordering and greedily choosing an edit to perform based on that ordering. In our algorithm, we use the *min-degree ordering* of a graph. The *min-degree ordering* is computed via the classic greedy algorithm given by Matula and Beck [71] that computes the degeneracy of the graph by repeatedly removing a minimum degree vertex from the graph. The degeneracy of G , $\text{degen}(G)$, is the maximum degree of a vertex when it is removed. In the following proofs, we make use of the observation that given a min-degree ordering L of the vertices in $G = (V, E)$ and assuming the edges are oriented from smaller to larger indices in L , $\text{deg}^+(u) \leq \text{degen}(G)$ ⁶ for any $u \in L$.

The first ordering L_0 is constructed by taking a min-degree ordering on the vertices of G where ties may be broken arbitrarily. Using L_0 , an edit is greedily chosen to be added to X . Each subsequent ordering L_i is constructed by taking a min-degree ordering on the vertices of $G \setminus X$ where ties are broken based on L_{i-1} . Specifically, if the vertices u and v have equal degree at the time of removal in the process of computing L_i , then $L_i(u) < L_i(v)$ if and only if $L_{i-1}(u) < L_{i-1}(v)$. The algorithm terminates when the min-degree ordering L_j produces a witness that the degeneracy of $G \setminus X$ is $r - 1$.

In order to determine which edit to make at step i , the algorithm first computes the forward degree of each vertex u based on the ordering L_i (equivalently, $\text{deg}^+(u)$ when edges are oriented from smaller to larger index in L_i). Each vertex with forward degree r is marked, and similarly, each edge that has a marked left endpoint is also marked. The algorithm selects the edit that *resolves*

⁶For notational reminders for $\text{deg}^+(u)$, please refer to Section 3.

the largest number of marked edges. We say that a marked edge is *resolved* if it will not be marked in the subsequent ordering L_{i+1} .

We observe that given an optimal edit set (of size k), removing the elements of the set in any order will resolve every marked edge after k rounds (assuming that at most one element from the optimal edit set is removed in each round). If it does not, then the final ordering L_k must have a vertex with forward degree r , a contradiction. Let m_i be the number of marked edges based on the ordering L_i . We show that we can always resolve at least $\frac{m_i}{k}$ marked edges in each round, giving our desired approximation.

Lemma 5.20. *A vertex that is unmarked in L_i cannot become marked in L_j for any $j > i$.*

Proof. For an unmarked vertex v to become marked, its forward degree must increase from $d \leq r-1$ to r when going from L_i to L_j for some $j > i$. In other words, $\deg^+_{L_i}(v) < r$ whereas $\deg^+_{L_j}(v) = r$. Since edges are not added to G , this can only occur if a backward neighbor u of v becomes a forward neighbor. Let $\{u, v\}$ be an *inversion* if $L_i(u) > L_i(v)$ but $L_j(u) < L_j(v)$ ⁷. An inversion can occur between neighbors u' and v' , in which case u' and v' are connected by an edge. We call this a *positive inversion* for u and a *negative inversion* for v . If the number of positive inversions for u of u 's neighbors is greater than the number of negative inversions of u 's neighbors between L_i and L_j , then $\deg^+_{L_j}(u) > \deg^+_{L_i}(u)$.

By our previous observation, an unmarked vertex can only become a marked vertex through inversions. Let u be a vertex that was unmarked in L_i but becomes marked in L_j . Let u and v be the first positive inversion for u in L_i (i.e. there is not a w such that u and w form a positive inversion for u and $L_i(w) < L_i(v)$). Because the algorithm breaks ties when constructing L_j based on L_{j-1} , if u and v form a positive inversion for u and u becomes marked in L_j , then $\deg^+_{L_j}(u) < \deg_{L_j[i_u, n]}(v)$ ⁸ and $\deg^+_{L_j}(u) = r$. (If, instead, $\deg^+_{L_j}(u) > \deg_{L_j[i_u, n]}(v)$, then v would have been removed first according to L_j .) Then, either (1) $\deg_{L_j[i_u, n]}(v) \leq \deg^+_{L_i}(v)$ or (2) $\deg_{L_j[i_u, n]}(v) > \deg^+_{L_i}(v)$.

If (1) occurs, then $\deg^+_{L_j}(u)$ cannot be r since this would imply $\deg^+_{L_i}(v) > r$, a contradiction. However, (2) can only occur through positive inversions of v (in fact, through positive inversions of v 's neighbors) since we chose v to be the first positive inversion of u . (Hence, v cannot gain additional edges in the range $L_j[i_u, i_v]$ when going from L_i to L_j .) Let w be the first positive inversion of v in L_j . Given that v must have at least one positive inversion with one of its neighbors, w must exist (it can either be the neighbor of v or another node.) The same case analysis applies to v and w , implying that w has a positive inversion and so on, eventually leading to a contradiction due to a lack of additional vertices to form a positive inversion. \square

Using Lemma 5.20, we are able to prove a similar statement about marked edges.

Lemma 5.21. *An edge that is unmarked in L_i cannot become marked in L_j for any $j > i$.*

Proof. Suppose WLOG that the edge $e = (u, v)$ is unmarked in L_i and that $L_i(u) < L_i(v)$. This implies that u is unmarked in L_i . By Lemma 5.20, u cannot become marked in L_j . Thus, in order for e to become marked, $L_j(v) < L_j(u)$ and $\deg^+_{L_j}(v) = r$. Since u is unmarked in L_j , we know that $\deg^+_{L_j}(u) \leq r-1$. So for $L_j(v) < L_j(u)$ where u and v are an inversion, the forward degree of v including u must be less than $r-1$. Thus, v must be unmarked in L_j , and so e is also unmarked. \square

⁷Note that u and v do **not** have to be connected by an edge.

⁸Let $\deg_{L_j[i_u, n]}(v)$ be the degree of v restricted to vertices between indices i_u and n in L_j . Here, i_u is the index of u .

Lemmas 5.20 and 5.21 allow us to make a claim about the number of marked edges that any one edit resolves.

Lemma 5.22. *For a given edit x , the number of marked edges that it resolves is monotonically non-increasing from L_0 . In other words, for any $i < j$, the number of marked edges x resolves in L_i is at least as many as the number of marked edges x resolves in L_j .*

Proof. By Lemma 5.21, we know that an unmarked edge cannot become marked. Thus, for the number of marked edges that an edit resolves in L_i to increase in L_{i+1} , an existing marked edge must become resolvable by making a different edit. Note that edits resolve edges by either deleting them or reducing the forward degree of marked vertices. Since the back neighbors of an edit x cannot become marked by Lemma 5.20 and any vertices that form a negative inversion with x via another edit must have forward degree at most $r - 1$, it is not possible for x to gain marked edges that are resolvable by deletion.

Instead, any new resolvable marked edges must be resolved by the deletion of x reducing the degree of a back neighbor by one. Note that changes to the set of resolvable edges can only occur if the relative ordering of the neighbors of x changes. First, we will consider the case where a forward neighbor v forms an inversion with neighbor x . After the inversion, the forward degree of v will be one less than the original forward degree of x . Furthermore, we note that v can now only form an inversion with its last back neighbor b assuming that the forward degree of b is exactly one greater than the forward degree of v . Thus, the forward edges of b are resolvable by x if they are marked. Note that there are exactly r of these edges if this is the case. However, this implies that the forward degree of v is $r - 1$, and so the original forward degree of x must have been r . These r edges must have been resolved by the inversion of v and x , so x resolves at most the same number of edges as it did originally. Note that if multiple forward neighbors form inversions with x simultaneously, only one of them can have forward degree $r - 1$.

Next, we consider the case where a back neighbor b of x forms an inversion with some other neighboring vertex v (potentially of no relation to x). Again, we rely on the fact that b must have forward degree $r - 1$ after the inversion in order to be able to make a second inversion that resolves additional marked edges. However, this implies that v originally had forward degree r , and so when b inverted with v , r marked edges were resolved. Since b can only form an inversion with one of its back neighbors per edit, there are at most r new marked edges that could be resolved by editing x . Thus, x resolves at most the same number of edges as it did originally.

Finally, we consider the case where v forms an inversion with a back neighbor b . In order for b to be able to form another inversion with a different marked neighbor, it must have forward degree $r - 1$. However, it must first form an inversion with v again which has already been considered. \square

Theorem 5.23. *There exists an $O(\log n)$ -approximation for finding the minimum size edit set to reduce the degeneracy of a graph from r to $r - 1$.*

Proof. Let m_0 be the number of marked edges in the first min-degree ordering. Since the optimal edit set (of size k) resolves every marked edge in k steps, the k edits must on average resolve $\frac{m_0}{k}$ marked edges. Thus, the largest number of marked edges resolved by an edit from the optimal edit set must be at least $\frac{m_0}{k}$. Fix a sequence of the optimal edit set. By Lemma 5.22, the number of marked edges that this edit resolves at the current step must be at least as large as when it appears in the optimal sequence. Thus, there must exist an edit which resolves at least $\frac{m_0}{k}$ marked edges, and so the edit that resolves the most marked edges must resolve at least $\frac{m_0}{k}$ as well. After one iteration then, there are $m_1 \leq m_0(1 - \frac{1}{k})$ marked edges remaining. Since the edited graph is a subgraph of the original, the optimal sized edit set must still be of size at most k and so the same

analysis applies. Thus, after t steps, there are at most $m_0(1 - \frac{1}{k})^t$ marked edges remaining. If we set $t = k \ln m_0$, then there are at most $m_0(1 - \frac{1}{k})^{k \ln m_0} \leq m_0 \cdot \frac{1}{e^{\ln m_0}} = 1$ marked edges remaining. Thus, we need at most $k \ln m_0 + 1$ iterations to resolve every marked edge. Since we add one edit at each iteration, we produce an edit set of size at most $k \ln m_0 + 1$. Because m_0 is at most n^2 , the size of the edit set is $k \ln m_0 + 1 \leq k \ln n^2 + 1 = O(k \log n)$. \square

Corollary 5.24. *There exists an $O(d \cdot \log n)$ -approximation for finding the minimum size edit set to reduce the degeneracy of a graph from r to $r - d$.*

Proof. Apply the above algorithm d times. Let G_i be the edited graph after i applications. Note that G_i has degeneracy $r - i$. The optimally sized edit set OPT to reduce the degeneracy of G_i from $r - i$ to $r - i - 1$ is at most the size of the smallest edit set to reduce the degeneracy of G_0 from r to $r - d$. Thus, at each iteration, we add at most $O(|\text{OPT}| \log n)$ edits to our edit set. After d iterations then, we have a graph with degeneracy $r - d$ and an edit set of size $O(d|\text{OPT}| \log n)$. \square

Corollary 5.25. *There exists an $O(r \cdot \log n)$ -approximation for finding the minimum size edit set to reduce the degeneracy of a graph to r .*

Proof. Apply an algorithm from Section 5.1 or 5.2. This yields a graph with degeneracy $O(r)$ and an edit set of size $O(|\text{OPT}|)$. Apply the algorithm from Corollary 5.24 to reduce the degeneracy by the remaining $O(r)$ steps. The final size of the edit set is $O(|\text{OPT}|) + O(r|\text{OPT}| \log n) = O(r|\text{OPT}| \log n)$. \square

5.5 Treewidth/Pathwidth: Bicriteria Approximation for Vertex Editing

In this section, we design a polynomial-time algorithm that constructs a $(O(\log^{1.5} n), O(\sqrt{\log w}))$ -bicriteria approximate solution to w -TREEWIDTH VERTEX DELETION: the size of the edit set is at most $O(\log^{1.5} n)$ times the optimum ($\text{OPT}_{w\text{-TW-V}}(G)$) and the resulting subgraph has treewidth $O(w\sqrt{\log w})$. We also give a $(O(\log^{1.5} n), O(\sqrt{\log w} \cdot \log n))$ -bicriteria approximation for editing to pathwidth w .

Our approach relies on known results for *vertex c -separators*, structures which are used extensively in many other algorithms for finding an approximate tree decomposition.

Definition 5.1. *For a subset of vertices W , a set of vertices $S \subseteq V(G)$ is a **vertex c -separator** of W in G if each component of $G[V \setminus S]$ contains at most $c|W|$ vertices of W . The minimum size vertex c -separator of a graph, denoted $\text{sep}_c(G)$, is the minimum integer k such that for any subset $W \subseteq V$ there exists a vertex c -separator of W in G of size k .*

The size of a minimum size vertex c -separator of a graph is a parameter of interest and has applications in bounding treewidth and finding an approximate tree decomposition. Our algorithms in this section use vertex $(\frac{3}{4})$ -separators.

Lemma 5.26 ([31, Section 6.2]). *There exist polynomial time algorithms that find a vertex $(\frac{3}{4})$ -separator of a graph G of size $c_1 \cdot \text{sep}_{2/3}(G) \sqrt{\log \text{sep}_{2/3}(G)}$, for a sufficiently large constant c_1 .*

The following bounds relating the treewidth of G , $\text{tw}(G)$, and the minimum size vertex $(\frac{2}{3})$ -separator of G , $\text{sep}_{2/3}(G)$, are useful in the analysis of our proposed algorithm for the problem of editing to treewidth w .

Lemma 5.27 ([81, 82, 44, Lemma 7]). *For any graph G , $\text{sep}_{2/3}(G) \leq \text{tw}(G) + 1 \leq 4\text{sep}_{2/3}(G)$.*

Lemma 5.28. For any graph $G = (V, E)$, and integer $w \leq \frac{3}{4} \cdot \text{tw}(G)$, $\text{sep}_{2/3}(G) \leq 6 \cdot \text{OPT}_{w\text{-TW-V}}(G)$.

Proof. It is straightforward to verify that for any $X \subseteq V$, if $\text{tw}(G[V \setminus X]) = w$, then $|X| \geq \text{tw}(G) - w$. Suppose not. Then, we can add X to all bags in the tree decomposition of $G[V \setminus X]$ and the resulting tree decomposition of G has treewidth less than $\text{tw}(G)$ which is a contradiction.

If we assume $w \leq \frac{3}{4} \cdot \text{tw}(G)$, then $\text{OPT}_{w\text{-TW-V}}(G) \geq \text{tw}(G) - w \geq \text{tw}(G)/4$, which, together with Lemma 5.27, implies that $\text{sep}_{2/3}(G) \leq \frac{3}{2} \cdot \text{tw}(G) \leq 6 \cdot \text{OPT}_{w\text{-TW-V}}(G)$. \square

5.5.1 Treewidth: $(O(\log^{1.5} n), O(\sqrt{\log w}))$ -approximation for vertex deletion

Our method exploits the general recursive approach of the approximation algorithms for constructing a tree decomposition [2, 8, 31, 80]. Our algorithm iteratively subdivides the graph, considering $G[V_i]$ in iteration i . We first apply the result of [8, 31] to determine if $G[V_i]$ has a tree decomposition with “small” width; if yes, the algorithm removes nothing and terminates. Otherwise, we compute an approximate vertex (3/4)-separator S of $G[V_i]$ (applying the algorithm of [31]), remove it from the graph, and recurse on the connected components of $G[V_i \setminus S]$. We show that the total number of vertices removed from G in our algorithm is not more than $O(\text{OPT}_{w\text{-TW-V}}(G) \log^{1.5} n)$ in Theorem 5.31 and the treewidth of the resulting graph is $O(w\sqrt{\log w})$ in Theorem 5.32.

Algorithm 3 Approximation for Vertex Editing to Bounded Treewidth Graphs

```

1: procedure TREEWIDTHNODEEDIT( $G = (V, E), w$ )
2:    $t \leftarrow$  compute  $\text{tw}(G)$  by invoking the algorithm of [8] together with [31]
3:   if  $t \leq 32c_1 \cdot w\sqrt{\log w}$  then
4:     return  $\emptyset$ 
5:   else
6:      $S \leftarrow$  compute a vertex  $(\frac{3}{4})$ -separator of  $G$  by invoking the algorithm of [31]
7:     let  $G[V_1], \dots, G[V_\ell]$  be the connected components of  $G[V \setminus S]$ .
8:     return  $(\bigcup_{i \leq \ell} \text{TREEWIDTHNODEEDIT}(G[V_i], w)) \cup S$ 
9:   end if
10: end procedure

```

The key observation in our approach is the following lemma:

Lemma 5.29. Suppose that the vertex set of $G = (V, E)$ is partitioned into V_1, \dots, V_ℓ . The minimum edit set of G to treewidth w has size at least $\sum_{i \leq \ell} \max(0, \text{tw}(G[V_i]) - w)$.

Proof. This directly follows from the straightforward observation that if $\text{tw}(G[V \setminus X]) = w$, then $|X| \geq \text{tw}(G) - w$. Since the sets of vertices are disjoint, then the lower bound on the number of vertices that must be deleted is the summation of the lower bound of the number of vertices that must be deleted in each disjoint set. \square

In Algorithm 3, we use the approach of Bodlaender et al. [8] together with the $O(\sqrt{\log \text{tw}(G)})$ -approximation algorithm of [31] for computing treewidth of G in Line 2.

Theorem 5.30 ([8, 31]). *There exists an algorithm that, given an input graph G , in polynomial time returns a tree decomposition of G of width at most $c_2 \cdot \text{tw}(G)\sqrt{\log \text{tw}(G)}$ and height $O(\log |V(G)|)$ for a sufficiently large constant c_2 .*

For the sake of completeness, we provide the proof of Theorem 5.30 in Section 5.5.3. Next, we analyze the performance of Algorithm 3.

Theorem 5.31. *Algorithm 3 removes at most $O(\log^{1.5} n) \text{OPT}_{w\text{-TW-V}}(G)$ vertices from any n -vertex graph G .*

Proof. The proof is by induction on the number of vertices in the given induced subgraph of G : we show that for any subset $V' \subseteq V$, the number of vertices removed by Algorithm 3 is at most $(c \cdot \log_{4/3} |V'| \cdot \sqrt{\log n}) \text{OPT}_{w\text{-TW-V}}(G[V'])$ where $c \geq 6$ is a fixed constant. We remark that c must also be greater than the constant c_2 in Theorem 5.30 for the width guarantee.

By the condition in Line 3 of the algorithm, the claim trivially holds for the case $|V| = O(w\sqrt{\log w})$. Assume that the claim holds for all induced subgraphs of G containing at most $n' - 1$ vertices. Next, we show that the claim holds for any n' -vertex induced subgraph of G , $G[V']$, too. If $t \leq 32c_1 \cdot w\sqrt{\log w}$, then no vertex is deleted and the claim holds. Otherwise,

$$\begin{aligned} 32c_1 \cdot w\sqrt{\log w} < t &\leq c_1 \cdot \text{sep}_{2/3}(G[V']) \sqrt{\log \text{sep}_{2/3}(G[V'])} && \text{by Lemma 5.26,} \\ &\leq c_1 \cdot (2\text{tw}(G[V'])) \sqrt{2 \log \text{tw}(G[V'])} && \text{by Lemma 5.27,} \end{aligned}$$

which implies that $\text{tw}(G[V']) \geq 4w$. By Lemma 5.28, $\text{sep}_{2/3}(G[V']) \leq 6 \text{OPT}_{w\text{-TW-V}}(G[V'])$ which implies that $|S'| \leq c_1 \sqrt{\log \text{sep}_{2/3}(G[V'])} \cdot \text{sep}_{2/3}(G[V']) \leq 6c_1 \sqrt{\log n} \cdot \text{OPT}_{w\text{-TW-V}}(G[V'])$ where S' is a vertex $(\frac{3}{4})$ -separator of V' computed in Line 6 of the algorithm.

Let V'_1, \dots, V'_ℓ be the disjoint components in $G[V' \setminus S']$. Then, $\text{OPT}_{w\text{-TW-V}}(G[V']) \geq \sum_{i \leq \ell} \text{OPT}_{w\text{-TW-V}}(G[V'_i])$, by Lemma 5.29. Further, by the induction assumption for each $i \leq \ell$, the number of vertices removed by $\text{TREEWIDTHNODEEDIT}(G[V'_i], w)$ is at most $(c \log_{4/3} |V'_i| \cdot \sqrt{\log n}) \text{OPT}_{w\text{-TW-V}}(G[V'_i])$. Hence, the vertices removed by $\text{TREEWIDTHNODEEDIT}(G[V'], w)$, satisfy

$$\begin{aligned} |X| &\leq 6c_1 \sqrt{\log n} \cdot \text{OPT}_{w\text{-TW-V}}(G[V']) + \sum_{i \leq \ell} (c \log_{4/3} |V'_i| \cdot \sqrt{\log n}) \cdot \text{OPT}_{w\text{-TW-V}}(G[V'_i]) \\ &\leq 6c_1 \sqrt{\log n} \cdot \text{OPT}_{w\text{-TW-V}}(G[V']) + (c \log_{4/3} \frac{3|V'|}{4} \cdot \sqrt{\log n}) \sum_{i \leq \ell} \text{OPT}_{w\text{-TW-V}}(G[V'_i]) \\ &\leq c \sqrt{\log n} \cdot (1 + \log_{4/3} |V'| - 1) \text{OPT}_{w\text{-TW-V}}(G[V']) && \text{with } c > 6c_1. \\ &\leq (c \log_{4/3} |V'| \cdot \sqrt{\log n}) \text{OPT}_{w\text{-TW-V}}(G[V']). \end{aligned}$$

□

Theorem 5.32. *The treewidth of the subgraph of G returned by Algorithm 3 is $O(w \cdot \sqrt{\log w})$.*

Proof. This follows immediately from the condition in Line 3 of the algorithm. □

5.5.2 Pathwidth: $(O(\log^{1.5} n), O(\sqrt{\log w} \cdot \log n))$ -approximation for vertex deletion

Our algorithm in this section builds on the reduction of Bodleander et al. [8] from tree decomposition to path decomposition and Algorithm 3 described in Section 5.5 for finding a minimum size edit set to treewidth w . The main component of the reduction approach of [8] is the following.

Lemma 5.33 ([8]). *Given a tree decomposition of G with width at most w and height at most h , we can find a path decomposition of G with width at most $w \cdot h$ efficiently.*

Corollary 5.34. *Given an input graph $G = (V, E)$ and a target pathwidth w , Algorithm 3 removes $O(\log^{1.5} n) \cdot \text{OPT}_{w\text{-PW-V}}(G)$ vertices X such that $\text{pw}(G[V \setminus X]) \leq (\sqrt{\log w} \cdot \log n) \cdot w$.*

Proof. By Theorem 5.31, $|X| \leq (\log^{1.5} n) \cdot \text{OPT}_{w\text{-TW-V}}(G)$. Since $\text{tw}(G) \leq \text{pw}(G)$ for all G , we have $\text{OPT}_{w\text{-TW-V}}(G) \leq \text{OPT}_{w\text{-PW-V}}(G)$. Hence, $|X| \leq \log^{1.5} n \cdot \text{OPT}_{w\text{-PW-V}}(G)$. Further, by Lemma 5.33 and Theorem 5.30, $\text{pw}(G[V \setminus X]) \leq (w\sqrt{\log w}) \cdot \log n$. \square

5.5.3 Proof of Theorem 5.30

In this section, we provide the proof of Theorem 5.30 which is essentially via the tree decomposition of Bodleander et al. [8] by plugging in the $O(\sqrt{\log \text{OPT}})$ -approximation algorithm of [31] for vertex separators. Algorithm 4 is the recursive approach of [8] for approximating treewidth (and constructing its tree decomposition).

Algorithm 4 Approximation Algorithm for Tree Decomposition (From [8, 31])

```

1: procedure TREEDECOMPOSITION( $G, Z, W$ )  $\langle\langle Z \cap W = \emptyset, \text{output contains } W \text{ in root bag} \rangle\rangle$ 
2:   if  $8|Z| \leq |W|$  then
3:     return a tree decomposition with a single node containing  $Z \cap W$ 
4:   else
5:      $S \leftarrow$  a vertex  $(\frac{3}{4})$ -separator of  $W$  in  $G[Z \cup W]$  by invoking the algorithm of [31]
6:      $T \leftarrow$  a vertex  $(\frac{3}{4})$ -separator of  $Z \cup W$  in  $G[Z \cup W]$  by invoking the algorithm of [31]
7:     let  $G[V_1], \dots, G[V_\ell]$  be the connected components of  $G[(W \cup Z) \setminus (S \cup T)]$ .
8:   end if
9:   for  $i = 1$  to  $\ell$  do
10:     $Z_i \leftarrow Z \cap V_i$ 
11:     $W_i \leftarrow W \cap V_i$ 
12:     $T_i \leftarrow$  TREEDECOMPOSITION( $G, Z_i, W_i \cup S \cup T$ )
13:   end for
14:   return the tree decomposition with  $(W \cup S \cup T)$  as its root and  $T_1, \dots, T_\ell$  as its children
15: end procedure

```

Claim 5.35. *If W and Z are disjoint sets of vertices of G and $|W| \leq 32c_1 \cdot \text{tw}(G)\sqrt{\log \text{tw}(G)}$, then the solution produced by the algorithm is a tree decomposition of $G[W \cup Z]$ of width at most $36c_1 \cdot \text{tw}(G)\sqrt{\log \text{tw}(G)}$.*

Proof. First we show that the output is a valid tree decomposition of $G[W \cup Z]$.

- **All edges of $G[Z \cup W]$ are covered in T .** The proof is by an induction on the recursive structure of the algorithm. For a leaf bag in the tree decomposition ($|Z| \leq |W|/8$), a single bag contains all vertices of $Z \cup W$; hence, the claim holds. Now, suppose that this property holds for all subtrees rooted at children of the tree decomposition constructed by TREEDECOMPOSITION(G, Z, W). Consider an edge $uv \in E$. If $u, v \in W$, then u and v are both contained in the root bag and it is covered in the tree decomposition. Otherwise, v and u both belong to $V_i \cup S \cup T$ for an $i \in [\ell]$ and by the induction hypothesis, uv is covered in the subtree T_i corresponding to TREEDECOMPOSITION($G, Z_i, W_i \cup S \cup T$). Thus, the property holds for T as well.
- **Bags containing each vertex are connected in tree structure T .** The proof is by induction on the recursive structure of TREEDECOMPOSITION(\cdot). More precisely, we show that for each pair (Z', W') , the bags containing a vertex $v \in Z' \cup W'$ are connected in TREEDECOMPOSITION(G, Z', W'). The property trivially holds for the leaves of T (the case

$|Z'| \leq |W'|/8$). Suppose that this property holds for all subtrees rooted at children of the tree decomposition $T = \text{TREEDecomposition}(G, Z, W)$. Then, we show that the property holds for T as well. If $v \in W \cup S \cup T$, then by the induction hypothesis on children of T , the property holds for T as well. Otherwise, v is only contained in one of the children of T (i.e., $v \in Z_i \cup W_i$) and by the induction hypothesis the property holds.

Next, we show that the width of the tree decomposition constructed by $\text{TREEDecomposition}(G, Z, W)$ is at most $36c_1 \cdot \text{tw}(G) \sqrt{\log \text{tw}(G)}$. By induction on the size of Z , it suffices to show that $|W \cup S \cup T| \leq 36c_1 \cdot \text{tw}(G) \sqrt{\log \text{tw}(G)}$ and for each i , $|W_i \cup S \cup T| \leq 32c_1 \cdot \text{tw}(G) \sqrt{\log \text{tw}(G)}$. Note that, by Line 3, if $|Z| \leq |W|/8$, then the returned tree decomposition has width at most $36c_1 \cdot \text{tw}(G) \sqrt{\log \text{tw}(G)}$. Suppose that the claim holds for all (Z', W') where $|Z'| < |Z|$. We bound the size of S and T as follows:

$$\begin{aligned} |S|, |T| &\leq c_1 \text{sep}_{2/3}(G) \sqrt{\log \text{sep}_{2/3}(G)} && \text{by Lemma 5.26,} \\ &< 4c_1 \cdot \text{tw}(G) \sqrt{\log \text{tw}(G)} && \text{by Lemma 5.27.} \end{aligned}$$

Since $|W| \leq 32c_1 \cdot \text{tw}(G) \sqrt{\log \text{tw}(G)}$, the root bag has size at most $(32c_1 + 2 \cdot 4c_1) \cdot \text{tw}(G) \sqrt{\log \text{tw}(G)}$. Moreover, since S and T are respectively a $(\frac{3}{4})$ -vertex separator of W and $W \cup Z$ in $G[W \cup Z]$, for each $i \in [\ell]$,

$$\begin{aligned} |Z_i| &\leq \frac{3}{4}|Z| < |Z|, \text{ and} \\ |W_i \cup S \cup T| &\leq \left(\frac{3}{4}32c_1 + 8c_1 \right) \cdot \text{tw}(G) \sqrt{\log \text{tw}(G)} \leq 32c_1 \cdot \text{tw}(G) \sqrt{\log \text{tw}(G)}. \end{aligned}$$

Thus, it follows from the induction hypothesis that the width of each subtree T_i is at most $36c_1 \cdot \text{tw}(G) \sqrt{\log \text{tw}(G)}$. \square

Proof of Theorem 5.30. It follows from Claim 5.35 that $\text{TREEDecomposition}(G = (V, E), \emptyset, V)$ constructs a tree decomposition of G of width at most $36c_1 \cdot \text{tw}(G) \sqrt{\log \text{tw}(G)}$. Moreover, since for each $i \in [\ell]$, $|Z_i| \leq 3|Z|/4$, the returned tree decomposition has height $O(\log |V(G)|)$. \square

5.6 Bounded Degree: Polynomial Time Algorithm for Edge Editing

We show a polynomial time algorithm for d -BOUNDED-DEGREE EDGE DELETION by a reduction to the problem of finding a minimum size f -edge cover of the graph.

Definition 5.2. *Given a function $f : V \rightarrow \mathbb{Z}^+$, an **f -edge cover** of a graph $G = (V, E)$ is a subset $F \subseteq E$ such that $\deg_{G[F]}(v) \geq f(v)$ for all $v \in V$.*

We use the following result to show a polynomial time algorithm for d -BDD-E.

Theorem 5.36 ([36, 46]). *Given a graph $G = (V, E)$, and function $f : V \rightarrow \mathbb{Z}^+$, there exists a polynomial time algorithm for finding a minimum size f -edge cover of G .*

Corollary 5.37. *There exists a polynomial time algorithm for d -BDD-E(G).*

Proof. It follows by an application of Theorem 5.36 to (G, f) where for each vertex v , $f(v) := \deg(v) - d$. \square

5.7 Treedepth 2: $O(1)$ -approximation for Editing

Star forests are exactly the family of graphs with treedepth equal to two. Thus, algorithms for editing to star forests may serve as a foundation for editing to larger values of treedepth. We refer to the vertex with degree greater than one in a star as its *center* (if a star is a single edge, arbitrarily pick a vertex to be the center). All other vertices are referred to as *leaves*.

We give polynomial-time $O(1)$ -approximations for STAR FOREST VERTEX DELETION and STAR FOREST EDGE DELETION based on HITTING SET.

Lemma 5.38. *There exists a polynomial-time 4-approximation for STAR FOREST VERTEX DELETION and a polynomial-time 3-approximation for STAR FOREST EDGE DELETION.*

Proof. It is straightforward to see that a graph is a star forest if and only if it does not contain P_4 or C_3 as a subgraph. Therefore for a given instance $G = (V, E), k$ of SF-V, we must delete at least one vertex from every P_4 and C_3 in G . We can enumerate all size-four and size-three sets of nodes in $O(n^4)$ time, and for each we can check if it is a P_4 or C_3 in constant time. If we let S be the set of subsets of V which are P_4 's or C_3 's then we have an instance of 4-HITTING SET, as each set in S must have a node from it deleted and the cardinality of each set is at most four. Finding a hitting set equates to finding an edit set X in our SF-V instance. Hochbaum [45] showed that there exists a polynomial-time k -approximation for k -HITTING SET, and thus there exists a polynomial-time 4-approximation for STAR FOREST VERTEX DELETION.

Our approach is similar for SF-E, but here we note there could be multiple P_4 's on a set of four nodes and deleting a single edge may not remove all of them (whereas deleting a single node would). Thus we must distinguish each edge-unique P_4 in S . We check if each of the permutations of nodes is a P_4 , and if it is we include the corresponding edges as a set in S (note that checking for only a permutation or its reverse is sufficient). We again use the result from [45], and as the cardinality of each set in S is at most three, we obtain a polynomial-time 3-approximation for SF-E. \square

We point out that, because there exists a finite list of forbidden subgraphs that characterizes graphs of treedepth bounded by p [76], the above hitting-set-based algorithm generalizes for the problem of deleting to any fixed treedepth p . Such an approximation may take time exponential in the size of the largest forbidden subgraph, but this size is a constant for fixed p , and so the approximation is still poly-time in $|V(G)|$.

6 Editing Hardness Results

6.1 Degeneracy: $o(\log(n/r))$ -Inapproximability of Vertex and Edge Editing

In this section, we prove the following inapproximability results for r -DE-V and r -DE-E.

Theorem 6.1. *For graphs G with n nodes and r satisfying $\text{degen}(G) > r \geq 2$, r -DEGENERATE EDGE DELETION and r -DEGENERATE VERTEX DELETION are $o(\log(n/r))$ -inapproximable.*

Reduction strategy. Our proof relies on a strict reduction from SET COVER. We prove that the graph constructed has degeneracy $r+1$, and that reducing its degeneracy to r requires deleting edges (vertices) from set gadgets that correspond to a solution for $\text{SC}(\mathcal{U}, \mathcal{F})$. We proceed by introducing the gadgets used in this reduction.

Mapping an instance of SET COVER to an instance of r -DEGENERATE DELETION. Given an instance $\text{SC}(\mathcal{U}, \mathcal{F})$, we want to define a function f that maps this instance to a graph $G = f(\mathcal{U}, \mathcal{F})$ as an instance of r -DE. This reduction relies on three gadgets which we describe here: *set*

gadgets and *element gadgets* represent the sets and elements of the set cover instance, while *split gadgets* enable us to connect the set and element gadgets to encode the containment relationships of $\text{SC}(\mathcal{U}, \mathcal{F})$.

Definition 6.1. *Given a fixed value $r \geq 2$, the corresponding **split gadget**, split , consists of $r+2$ vertices: r vertices connected in a clique, and two vertices, labeled t and b (for “top” and “bottom”) each connected to all r clique vertices. See Figure 2 for a visualization.*

Definition 6.2. *Given a fixed value $r \geq 2$, an instance $\text{SC}(\mathcal{U}, \mathcal{F})$, and a set $S \in \mathcal{F}$, we define the **set gadget** DS_S as follows. The gadget consists of a length- r path x_1, \dots, x_r ; an independent W set of r nodes, w_1, \dots, w_r each of which is connected to every vertex x_j ; a **set vertex** v_S connected to W ; and two instances of **split**, each of which is connected to v_S by a single edge from its b vertex. See Figure 3 for a visualization.*

Definition 6.3. *Given a fixed value $r \geq 2$, an instance $\text{SC}(\mathcal{U}, \mathcal{F})$, and an element $e \in \mathcal{U}$, we define the corresponding **element gadget** \mathbf{G}_e as follows. Let f_e be the number of sets in \mathcal{F} that contain e . The gadget consists of $2rf_e$ total vertices:*

1. rf_e vertices z_j^i connected in a cycle, where $j = 1, \dots, r$ and $i = 1, \dots, f_e$;
2. $(r-1)f_e$ independent vertices a_j^i , where $j = 1, \dots, r-1$ and $i = 1, \dots, f_e$; and
3. f_e independent vertices $v_e^1, \dots, v_e^{f_e}$.

For each i , the vertices $\{z_j^i\}_{j=1}^r$ and the vertex v_e^i are completely connected to the vertices $\{a_j^i\}_{j=1}^{r-1}$. See Figure 4 for a visualization.

The motivation for these gadgets, as we will prove below, is that, once the gadgets are linked together properly, every vertex will have degree at least $r+1$, and each set gadget DS_S remains in the $(r+1)$ -core until either a vertex in DS_S is deleted or all element gadgets attached to it have been deleted. Before proving these properties, we first describe our map f from SC to r -DE.

Definition 6.4. *Given an instance $\text{SC}(\mathcal{U}, \mathcal{F})$, we construct an instance $G = f(\mathcal{U}, \mathcal{F})$ of r -DE as follows. For each element $e \in \mathcal{U}$, the graph G contains one element gadget \mathbf{G}_e (Definition 6.3). For each set $S \in \mathcal{F}$, G contains one set gadget DS_S (Definition 6.2); for each element $e \in S$, an edge connects one of the vertices $v_e^i \in \mathbf{G}_e$ to both of the vertices $t \in \text{split}_1$ and $t \in \text{split}_2$ in DS_S . If a set S contains more than r elements, then the instances split_j in DS_S are first attached to additional copies of **split**, such that no instance of **split** has its vertex t attached to more than r edges. See Figure 5.*

Note that the above definitions require $r \geq 2$ and $f_e \geq 2$ in order for the cycle structure in the element gadget to make sense. This requirement can easily be satisfied by pre-processing the instance $\text{SC}(\mathcal{U}, \mathcal{F})$ to remove trivial elements with $f_e = 1$.

Next we establish some properties of these gadgets that will be useful in proving Theorem 6.1.

Lemma 6.2. *In the graph $G = f(\mathcal{U}, \mathcal{F})$ from Definition 6.4, if $|S| > r$, then the set gadget DS_S requires exactly $2 \left\lceil \frac{|S|-r}{r-1} \right\rceil$ additional copies of **split** to connect $\text{split}_1, \text{split}_2 \in \text{DS}_S$ to all of the element gadgets \mathbf{G}_e for $e \in S$.*

Proof. Each $\text{split}_j \in \text{DS}_S$ must be able to attach to a vertex of the form $v_e^j \in \mathbf{G}_e$ for each $e \in S$. This requires $|S|$ edges; since each instance of **split** provides (up to) r edges out of its vertex t , but each additional copy of **split** uses one such edge to connect to its vertex b , the total number ℓ of additional copies of **split** is the smallest integer satisfying $(r-1)\ell + r \geq |S|$. Choosing $\ell = \left\lceil \frac{|S|-r}{r-1} \right\rceil$ guarantees this. Since DS_S has two **split** gadgets and each requires the same number of additional edges, this completes the proof. \square

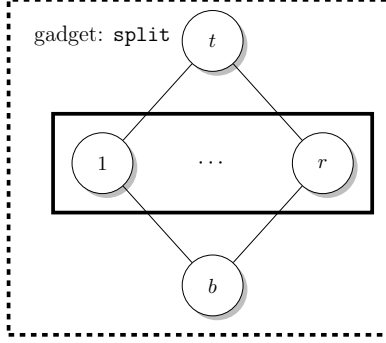

Figure 2: The gadget `split`, described in Definition 6.1, provides the mechanism by which we connect a set gadget, DS_S , to each of the element gadgets G_e for $e \in S$.

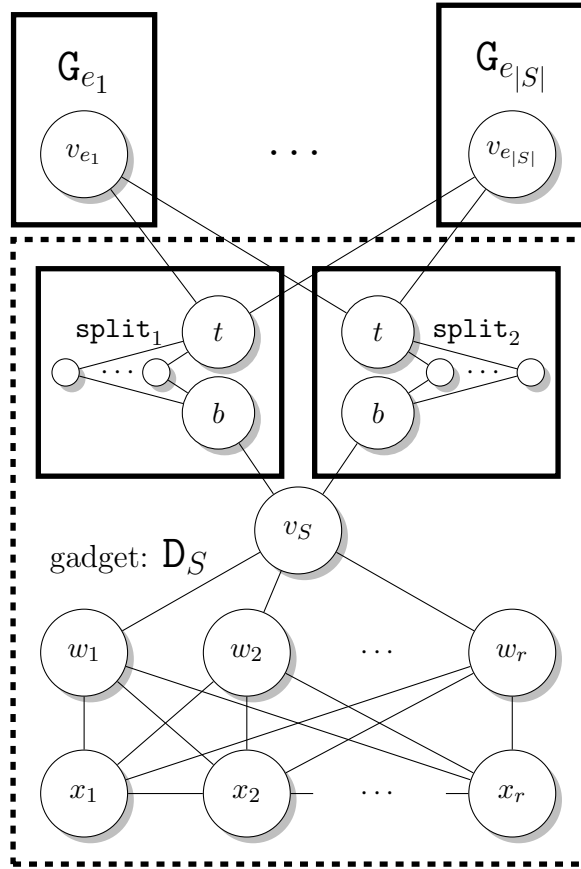

Figure 3: DS_S is the gadget corresponding to set $S \in \mathcal{F}$, described in Definition 6.2.

We now give a precise bound on the size of the graph $G = f(\mathcal{U}, \mathcal{F})$.

Lemma 6.3. *Given $r \geq 2$ and an instance $SC(\mathcal{U}, \mathcal{F})$, the graph $G = f(\mathcal{U}, \mathcal{F})$ (Definition 6.4) has size $n \leq 10r|\mathcal{U}||\mathcal{F}|$, and the map f can be constructed in time polynomial in $|\mathcal{U}|, |\mathcal{F}|$, and r .*

Proof. Each DS_S contains $4r + 5$ vertices, plus $r + 2$ vertices per additional copy of `split` needed to connect DS_S to the gadgets G_e . By Lemma 6.2, we use $2 \left\lceil \frac{|S| - r}{r - 1} \right\rceil \leq 2((|S| - r)/(r - 1) + 1) = 2(|S| - 1)/(r - 1)$ copies of `split`. Since $r \geq 2$, we can upperbound $(r + 2)/(r - 1)$ by 4, and so

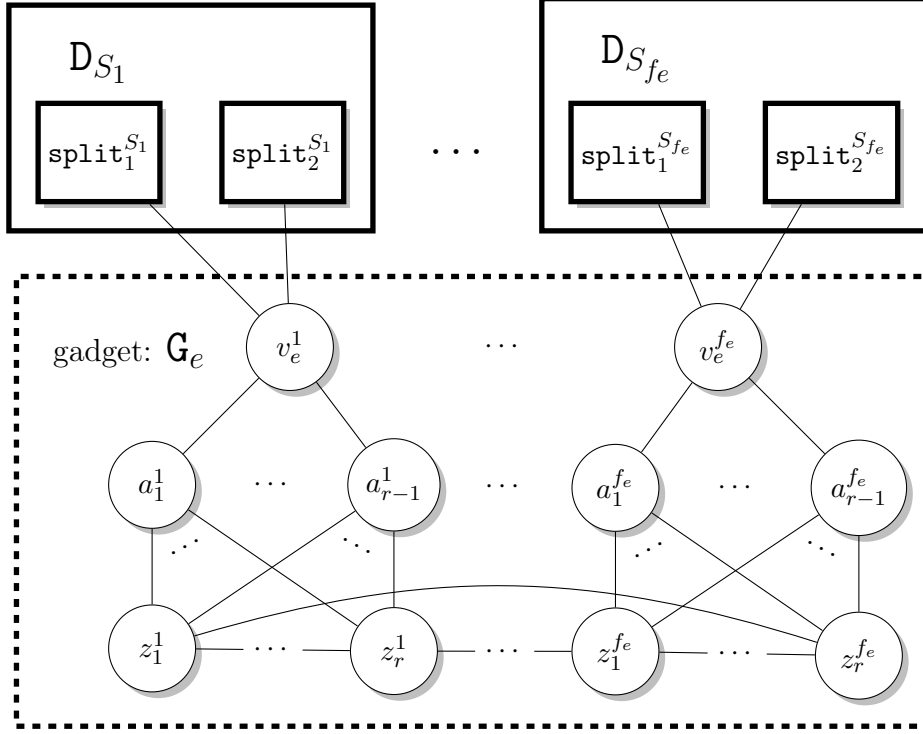

Figure 4: \mathbf{G}_e is the gadget corresponding to element $e \in \mathcal{U}$, described in Definition 6.4.

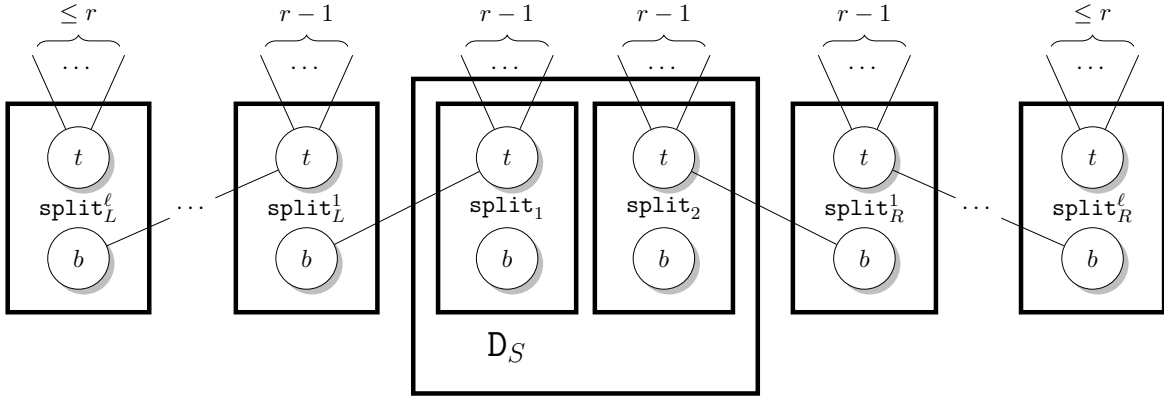

Figure 5: By linking together instances of **split**, we can connect the gadget \mathbf{DS}_S to all $|S|$ element gadgets \mathbf{G}_e with $e \in S$ while also guaranteeing no vertex t in an instance of **split** has more than r external edges. An instance of **split** is connected to an element gadget \mathbf{G}_e by a single edge from the vertex t in **split** to a vertex in \mathbf{G}_e . In each instance of **split**, the vertex b is connected via a single edge to either the node v_S in a set gadget \mathbf{DS}_S , or to a vertex t in another instance of **split**. See Definition 6.4.

the total number of vertices in extra **split** copies for a \mathbf{DS}_S is bounded by $8|S| - 8$. Thus, the gadget \mathbf{DS}_S and associated copies of **split** have at most $4r - 3 + 8|S|$ vertices. Each \mathbf{G}_e contains $2rf_e$ vertices. Since G contains a copy of \mathbf{G}_e for each $e \in \mathcal{U}$, and a gadget \mathbf{DS}_S for each $S \in \mathcal{F}$, we have

$$n \leq \sum_{e \in \mathcal{U}} 2rf_e + \sum_{S \in \mathcal{F}} (4r - 3 + 8|S|) \leq 2r|\mathcal{U}||\mathcal{F}| + 4r|\mathcal{F}| + 8 \sum_{S \in \mathcal{F}} |S|.$$

Observing that $8 \sum_{S \in \mathcal{F}} |S| \leq 4r|\mathcal{U}||\mathcal{F}|$ and $4r|\mathcal{F}| \leq 4r|\mathcal{U}||\mathcal{F}|$, we get $n \leq 10r|\mathcal{U}||\mathcal{F}|$. \square

Lemma 6.4. *Given $r \geq 2$ and an instance $\text{SC}(\mathcal{U}, \mathcal{F})$, the graph $G = f(\mathcal{U}, \mathcal{F})$ (Definition 6.4) has degeneracy $r + 1$. Moreover, for each set S the induced subgraph $G[\text{DS}_S]$ has degeneracy r , and for each element e , all vertices in \mathbf{G}_e are not in the $(r + 1)$ -core if at least one vertex $v_e^j \in \mathbf{G}_e$ has both of its external edges removed. Finally, in any copy of **split**, if either t or b has no external edges attached to it, then the vertices in **split** are not in the $(r + 1)$ -core; otherwise, they are in the $(r + 1)$ -core.*

Proof. By the construction and the assumptions that no $S \in \mathcal{F}$ is empty and each element $e \in \mathcal{U}$ is contained in at least two sets, we know every vertex has degree at least $r + 1$ in G . To see that G has degeneracy exactly $r + 1$, we exhibit an ordering to use Lemma 3.1. Note that all vertices w_j in set gadgets DS_S have degree $r + 1$. Removing these leaves the vertices $v_S, x_j \in \text{DS}_S$ (for each $j \leq r$) with degree two or less, so they can be removed as well. After this, all vertices remaining in G have degree $r + 1$ or less, possibly with the exception of the vertices t in copies of **split**. After removing all vertices other than those labeled t in instances of **split**, then those vertices have degree $\leq r$ as well. This proves G has degeneracy $r + 1$.

To see that the vertices of **split** are not in the $(r + 1)$ -core if t or b has no external edges, consider the vertex ordering starting with either t or b (whichever vertex has no external edges to it), then the r clique vertices in **split**, and finally the remaining vertex.

Suppose $v_e^0 \in \mathbf{G}_e$ has had its edges external to \mathbf{G}_e removed; then v_e^0 has degree $r - 1$ and the vertices of \mathbf{G}_e are not in the $(r + 1)$ -core as witnessed by the vertex ordering $v_e^0, \{a_i^0\}_i, \{z_i^0\}_i, \{z_i^j\}_{i,j}, \{a_i^j\}_{i,j}, \{v_e^j\}_j$. The degeneracy r of the induced subgraph $G[\text{DS}_S]$ is exhibited by the vertex ordering $t_1, t_2, \text{split}_1, \text{split}_2, v_S, \{w_j\}_j, \{x_j\}_j$. \square

Lemma 6.5. *Given instance $\text{SC}(\mathcal{U}, \mathcal{F})$, let $G = f(\mathcal{U}, \mathcal{F})$ (Definition 6.4). Let $\mathcal{T} \subseteq \mathcal{F}$ be any set cover for $\text{SC}(\mathcal{U}, \mathcal{F})$. Let $y' \subseteq V(G)$ ($y' \subseteq E(G)$) be any set of vertices (edges) such that for each $S \in \mathcal{T}$, the set $y' \cap V(\text{DS}_S)$ is non-empty (the set $y' \cap E(\text{DS}_S)$ contains at least one edge incident to a vertex w_j). Then y' is a feasible solution for r -DE-V(G) (r -DE-E(G)).*

Proof. We first prove the lemma for r -DE-E. Deleting any edge in a gadget DS_S that is incident to a vertex w_j makes the degree of that vertex r —thus, that vertex is removed from the $(r + 1)$ -core; this decreases the degree of the neighbors x_i of w_j to r as well, and by induction each x_i in DS_S is removed from the $(r + 1)$ -core. This removes all w_j from the $(r + 1)$ -core, which then removes v_S , and by Lemma 6.4, both **split** gadgets. Furthermore, this causes all edges leaving DS_S to be removed, and so all **split** and \mathbf{G}_e gadgets attached to those edges then leave the $(r + 1)$ -core, by Lemma 6.4. By assumption, \mathcal{T} is a set cover, and so the set of gadgets DS_S for $S \in \mathcal{T}$ necessarily connect to every element gadget \mathbf{G}_e in G . This shows that every \mathbf{G}_e is removed from the $(r + 1)$ -core of $G \setminus y'$.

With every element gadget \mathbf{G}_e removed from the $(r + 1)$ -core of $G \setminus y'$, every edge going from a vertex in \mathbf{G}_e to a vertex t in a copy of **split** is removed; this means all copies of **split** are removed from the $(r + 1)$ -core by Lemma 6.4. This means that every set gadget DS_S (which wasn't already removed because $S \in \mathcal{T}$) has no external edges to element gadgets or **split** gadgets, and so by Lemma 6.4 each DS_S is removed from the $(r + 1)$ -core. Hence, $G \setminus y'$ has degeneracy r .

To see that the result also holds for vertex deletions, note that if y' contains any vertex in a set gadget DS_S , then deleting y' necessarily removes that instance of DS_S from the $(r + 1)$ -core of $G \setminus y'$. The rest of the proof follows as above. \square

Mapping a graph deletion set to a SET COVER solution.

Definition 6.5. Given instance $\text{SC}(\mathcal{U}, \mathcal{F})$, let $G = f(\mathcal{U}, \mathcal{F})$ (Definition 6.4). For any feasible solution $y' \subset V(G)$ ($y' \subset E(G)$) to $r\text{-DE-V}(G)$ ($r\text{-DE-E}(G)$), we construct a **map g from $r\text{-DE to SC}$** that maps y' to a solution $g(y')$ for $\text{SC}(\mathcal{U}, \mathcal{F})$ in two steps:

1. Construct a **canonical edit set** \hat{y} as follows: for each set $S \in \mathcal{F}$, let $H_S \subset G$ be the subgraph formed by DS_S , \mathbf{G}_e for each element $e \in S$, and every **split** lying on a path from DS_S to any such \mathbf{G}_e . If $H_S \cap y'$ is non-empty, then add the vertex v_S (or the edge (v_S, w_1)) to \hat{y} .
2. Set $g(y') = \{S \in \mathcal{U} \mid \hat{y} \cap \text{DS}_S \neq \emptyset\}$.

Lemma 6.6. In the notation of Definition 6.5, with $G = f(\mathcal{U}, \mathcal{F})$, for a feasible solution y' to $r\text{-DE}(G)$, the corresponding set \hat{y} is a feasible solution to $r\text{-DE}(G)$, the set $g(y')$ is a feasible solution to $\text{SC}(\mathcal{U}, \mathcal{F})$, and they satisfy $|g(y')| \leq |\hat{y}| \leq |y'|$.

Proof. For each element $e \in \mathcal{U}$ let H_e be the subgraph formed by \mathbf{G}_e , the set gadgets DS_S for each set $S \in \mathcal{F}$ containing e , and every gadget **split** lying on a path from each such DS_S to \mathbf{G}_e .

Let y' be a feasible solution to $r\text{-DE}(G)$ and suppose the corresponding canonical solution \hat{y} is infeasible. Consider the subgraph $H_e^+ = H_e \cup (\bigcup_{S:e \in S} H_S)$ of G . If for each $e \in \mathcal{U}$ we have that $\hat{y} \cap H_e^+$ is non-empty, then \hat{y} would be feasible. To see this, observe that in this situation each \mathbf{G}_e would be removed from the $(r+1)$ -core, and if all \mathbf{G}_e are removed from the $(r+1)$ -core, then each gadget DS_S is also removed, leaving the $(r+1)$ -core empty. Thus, $\hat{y} \cap H_e^+$ is empty for some e . However, since y' is feasible, $y' \cap H_e^+ \neq \emptyset$ for every e ; in particular, $y' \cap H_S$ must be non-empty for some S containing e . By Definition 6.5, $\hat{y} \cap H_S$ must then be non-empty, a contradiction.

Given a feasible solution y' to $r\text{-DE}(G)$, let \hat{y} be the corresponding canonical solution and suppose that $g(y')$ is not a feasible solution to SC . Then there is at least one element $e \in \mathcal{U}$ that is not covered by $g(y')$. Hence, for each set $S \in \mathcal{F}$ containing e , we have that $\hat{y} \cap H_S$ is empty. Since e is not covered by $g(y')$ by assumption, then by construction \hat{y} contains no edge (vertex) in H_e^+ . We will show this implies that H_e^+ has minimum degree $r+1$. Since H_e^+ has no edge (vertex) in \hat{y} , in particular \hat{y} contains no edge (vertex) of \mathbf{G}_e , any DS_S with $e \in S$, or any instance of **split** lying on a path between \mathbf{G}_e and such a DS_S . Thus, vertices in each DS_S have degree at least $r+1$, since the vertices $t \in \text{split}_j \in \text{DS}_S$ each have at least one external edge on a path to \mathbf{G}_e ; clearly the instances **split** lying on paths from DS_S to \mathbf{G}_e each have minimum degree $r+1$; furthermore, since H_e^+ contains DS_S for each S containing e , each vertex $v_e^j \in \mathbf{G}_e$ has two external edges connected to instances **split**. Since no edges (vertices) internal to \mathbf{G}_e are missing, this proves H_e^+ has minimum degree $r+1$. This contradicts feasibility of \hat{y} , so $g(y')$ must be feasible.

The inequalities follow directly from the definitions of the sets \hat{y} and $g(y')$. \square

Strict reduction from SET COVER. In the notation of Definition 6.4, fix an instance $\text{SC}(\mathcal{U}, \mathcal{F})$ and corresponding instance $r\text{-DE}(G)$. We can now prove the main theorem of this section.

Proof of Theorem 6.1. By Lemma 6.3, the map f can be computed in time polynomial in $|\mathcal{U}|, |\mathcal{F}|$, and r . We also observe that, given a feasible solution y' to $r\text{-DE}(G)$, the map g gives a polynomial time construction of a solution $g(y')$ to $\text{SC}(\mathcal{U}, \mathcal{F})$. Furthermore, by Lemma 6.6, we know that $\text{Cost}_{\text{SC}}(g(y')) \leq \text{Cost}_{r\text{-DE}}(y')$. In particular, this implies $\text{OPT}_{\text{SC}}(\mathcal{U}, \mathcal{F}) \leq \text{OPT}_{r\text{-DE}}(G)$.

On the other hand, given any solution y to $\text{SC}(\mathcal{U}, \mathcal{F})$, the set $\hat{y} = \{v_S \mid S \in y\}$ is a valid solution for $r\text{-DE-V}(f(\mathcal{U}, \mathcal{F}))$ by Lemma 6.5 and satisfies $\text{Cost}_{\text{SC}}(y) \geq \text{Cost}_{r\text{-DE-V}}(\hat{y})$. Additionally, the set $\hat{y} = \{(v_S, w_1) \mid S \in y\}$ is a valid solution for $r\text{-DE-E}$ and satisfies $\text{Cost}_{\text{SC}}(y) \geq \text{Cost}_{r\text{-DE-E}}(\hat{y})$. In particular, for optimal y this implies $\text{OPT}_{\text{SC}}(\mathcal{U}, \mathcal{F}) \geq \text{OPT}_{r\text{-DE}}(f(\mathcal{U}, \mathcal{F}))$ completing a proof that $\text{OPT}_{\text{SC}}(\mathcal{U}, \mathcal{F}) = \text{OPT}_{r\text{-DE}}(f(\mathcal{U}, \mathcal{F}))$ for both vertex and edge deletion.

This proves that maps f and g satisfy the conditions of Definition 3.9. Finally, by Lemma 6.3 the map f creates a graph with $n \leq 10r|\mathcal{U}||\mathcal{F}|$. By Theorem 3.5, we can assume that $|\mathcal{F}| \leq |\mathcal{U}|^C$ for some constant $C > 0$, so we have $\log(n/r) \leq \log(|\mathcal{U}|^{C+1})$. Thus, there exists a constant $C_1 > 0$ such that a $C_1 \cdot \ln(n/r)$ -approximation for r -DE(G) would give an $(1 - \varepsilon)(\ln |\mathcal{U}|)$ -approximation for all SC instances with $|\mathcal{F}| \leq |\mathcal{U}|^C$. \square

6.2 Weak Coloring Numbers: $o(t)$ -Inapproximability of Editing

In this section, we explore the hardness of editing a graph G so that it has weak c -coloring number at most t (see Definition 3.3). Because it is NP-hard to decide whether a graph has weak c -coloring number at most t , it is trivially hard to guarantee a finite approximation ratio for editing graphs which already have weak c -coloring number at most t into the desired class. By contrast, our hardness-of-approximation results apply when editing graphs that are far from the target class, which is the most favorable scenario for approximation. Throughout this section, we say a vertex u can *reach* another vertex v with respect to an ordering L if $v \in \text{wreach}_c(G, L, u)$.

We examine three variants of the problem—namely vertex-deletion, edge-deletion, and edge-contraction—and prove the following results.

Theorem 6.7. *For each fixed $c > 2$ and constant $t \geq \max\{12, \lfloor c/2 \rfloor + 4\}$, t -BOUNDED WEAK c -COLORING NUMBER EDITING (t -BWE- c) is $o(t)$ -inapproximable. Furthermore, there exists a constant $b > 0$ such that t -BWE- c is $o(t)$ -inapproximable for $t \in O(\log^{1/b} n)$, unless $NP \subseteq DTIME(n^{O(\log \log n)})$.*

The case where $c = 1$ is equivalent to editing a graph to have *degeneracy* t , and it is handled in Section 6.1. The case where $c = 2$ uses a similar construction to when $c > 2$ and is explained at the end of this section.

Reduction Strategy. We proceed via a strict reduction from a variant of SET COVER called k -UNIFORM SET COVER (see Section 3.3).

We describe a function f that maps an instance $(\mathcal{U}, \mathcal{F})$ of SET COVER to a graph $G = f(\mathcal{U}, \mathcal{F})$. The graph G consists of an element gadget EG_x for each element $x \in \mathcal{U}$ and a set gadget SG_S for each set $S \in \mathcal{F}$ such that the gadget EG_x contains SG_S when $x \in S$. Thus, two gadgets EG_x and $\text{EG}_{x'}$ overlap on SG_S for every set $S \in \mathcal{F}$ with $x, x' \in S$. For an edit set y' , we show that $\text{wcol}_c(G \setminus y') \leq t$ if and only if $\text{wcol}_c(\text{EG}_x \setminus y') \leq t$ for all $x \in \mathcal{U}$. Additionally, we show that $\text{wcol}_c(\text{EG}_x \setminus y') \leq t$ if every EG_x contains a SG_S that was edited. We define a canonical solution to t -BWE- c so that all of the edits appear in set gadgets and then use a bijective mapping between problems to obtain the necessary inequalities. We begin by introducing the gadgets in this reduction.

Gadgets. Let f_x be the frequency of x in \mathcal{F} , and let $f_{\max} = \max_{x \in \mathcal{U}}(f_x)$. We note that $f_x \geq 1$ trivially for all $x \in \mathcal{U}$ in all hard instances $(\mathcal{U}, \mathcal{F})$. Let $\ell = \lfloor \frac{c}{2} \rfloor$ and let t be the smallest integer that satisfies $t \geq 4 \cdot f_{\max}$ and $t \geq \ell + 3 \cdot f_{\max} - 2$. Note that $\ell \geq 1$ since $c > 2$.

Definition 6.6. *The set gadget SG_S , depicted in Figure 6, consists of two vertex-disjoint cliques D_S^1 and D_S^2 of sizes t and $t + 1$, respectively. We distinguish one vertex $v_S^1 \in D_S^1$ and another vertex $v_S^2 \in D_S^2$ and connect them by an edge.*

Definition 6.7. *Each element gadget EG_x , depicted in Figure 7, contains a clique D_x of size $t - 3 \cdot f_x + 2$. Note that, by our choice of t , D_x always contains at least one vertex. For each $S \in \mathcal{F}$ which contains x , EG_x contains SG_S and an additional clique $D_{S,x}$ of size f_x . For each set $S \in \mathcal{F}$ for which $x \in S$, there is a vertex $p_{S,x}^1$ connected to all vertices in D_x and $D_{S,x}$. Additionally, the vertex*

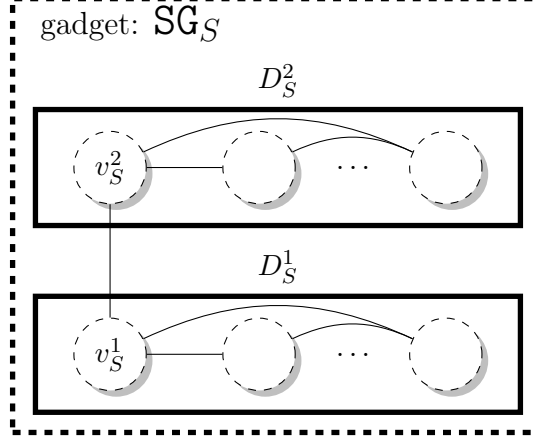

Figure 6: The set gadget \mathbf{SG}_S (Definition 6.6). \mathbf{SG}_S contains cliques D_S^1 of size t and D_S^2 of size $t + 1$ with distinguished vertices v_S^1 and v_S^2 , respectively, connected by an edge.

$p_{S,x}^1$ is in a path of length ℓ , $\{p_{S,x}^1 \dots p_{S,x}^\ell\}$, and the vertex $p_{S,x}^\ell$ is connected to v_S^1 in an instance of \mathbf{SG}_S .

Reduction. We now define reduction functions f and g (Definition 3.9).

Definition 6.8. Given a SET COVER instance $(\mathcal{U}, \mathcal{F})$, the function $\mathbf{f}(\mathcal{U}, \mathcal{F})$ produces the corresponding t -BWE- c instance G . Specifically, G contains a set gadget \mathbf{SG}_S for every $S \in \mathcal{F}$ as described in Definition 6.6. Using the set gadgets, G contains an element gadget \mathbf{EG}_x for every $x \in \mathcal{U}$ as described in Definition 6.7. The graph G is the union of these element gadgets.

Before we demonstrate the mapping between solutions for SET COVER and t -BWE- c , we first show that f is polynomial time computable and produces non-trivial instances of t -BWE- c .

Lemma 6.8. The function f defined in Definition 6.8 which produces the t -BWE- c instance G from the SET COVER instance $(\mathcal{U}, \mathcal{F})$ is polynomial time computable.

Proof. First, we note that G includes one set gadget, \mathbf{SG}_S , for each set $S \in \mathcal{F}$, and each such gadget has exactly $2t + 1$ vertices. Next, we observe that for each element $x \in \mathcal{U}$, G contains an element gadget \mathbf{EG}_x that has $(f_x^2 + (\ell - 3)f_x + t + 2)$ vertices: f_x vertices in each of f_x cliques labelled D_{S,x^j} for $j = 1, \dots, f_x$; $t - 3f_x + 2$ vertices for the clique D_x ; and f_x paths of length ℓ , $p_{S,x}^j$. Then, $n = |V(G)|$ satisfies

$$\begin{aligned} n &= |\mathcal{F}|(2t + 1) + \sum_{x \in \mathcal{U}} (f_x^2 + (\ell - 3)f_x + t + 2) \\ &\leq |\mathcal{F}|(2t + 1) + |\mathcal{U}|(t + 2) + |\mathcal{U}|t^2, \end{aligned}$$

since $t \geq f_x$ and $t \geq \ell + f_x - 3$ by construction. Thus the number of vertices (and therefore edges) in G is polynomial in $|\mathcal{U}|$, $|\mathcal{F}|$, t , and c . \square

In order to show that an instance $G = \mathbf{f}(\mathcal{U}, \mathcal{F})$ of t -BWE- c is non-trivial, we show that the weak c -coloring number of G is greater than t . To prove this, we will use the fact that weak c -coloring number is a hereditary property.

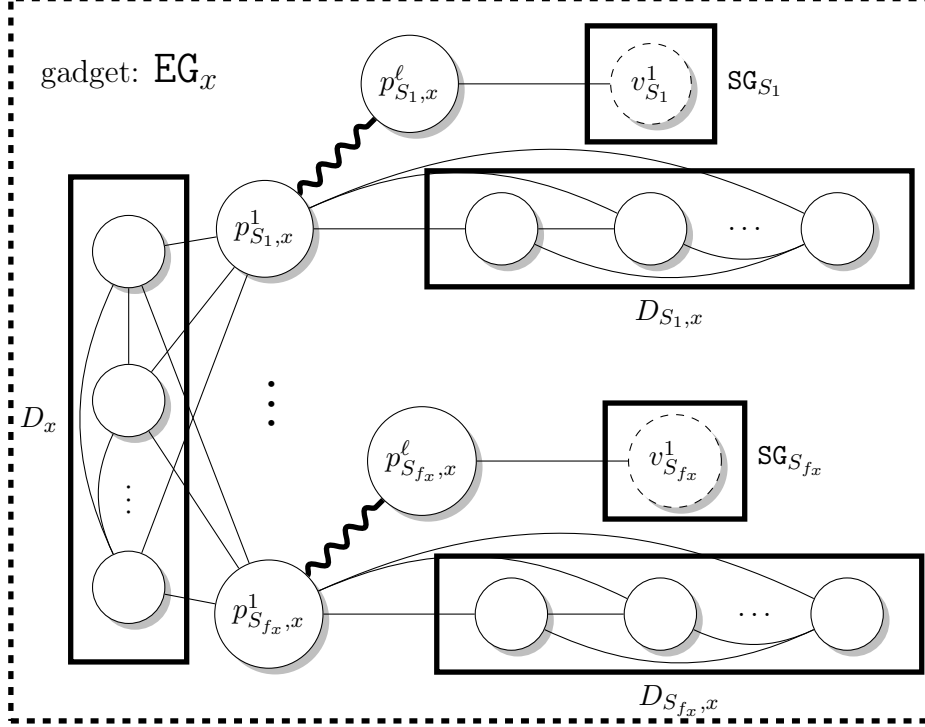

Figure 7: The element gadget \mathbf{EG}_x (Definition 6.7). It contains a clique D_x of size $t - 3 \cdot f_x + 2$ and a clique $D_{S,x}$ of size f_x for each $S \in \mathcal{F}$ that contains x . \mathbf{EG}_x also contains the set gadget \mathbf{SG}_S for each S that contains x , and each vertex in D_x and $D_{S,x}$ is connected to \mathbf{SG}_S by a path of length ℓ (indicated by the squiggly line).

Lemma 6.9. *For any graph H , if $\text{wcol}_c(H) \leq t$, then for each induced subgraph H' of H , $\text{wcol}_c(H') \leq t$.*

Proof. Suppose that $\text{wcol}_c(H) \leq t$ for a graph H . By Definition 3.3, there exists an ordering L such that $|\text{wreach}_c(H, L, v)| \leq t$ for all $v \in V(H)$. Then, $|\text{wreach}_c(H', L, v)| \leq |\text{wreach}_c(H, L, v)|$ for any $v \in V(H')$ since H' is an induced subgraph. Thus, $\text{wscore}_c(H', L) \leq t$ and $\text{wcol}_c(H') \leq t$ as desired. \square

In particular, the contrapositive of Lemma 6.9 will be useful.

Corollary 6.10. *If $\text{wcol}_c(H') > t$ for any induced subgraph H' of H , then $\text{wcol}_c(H) > t$.*

Now, we need only show that $\text{wcol}_c(\mathbf{EG}_x) > t$ for some $x \in \mathcal{U}$. To show that $\text{wcol}_c(\mathbf{EG}_x) > t$, we establish structural properties that hold for any ordering L that would satisfy $\text{wscore}_c(\mathbf{EG}_x, L) \leq t$ and then show that no such ordering can exist. We first prove that the vertices $v_S^1, v_S^2, p_{S,x}^1$ can be assumed to come after every vertex in D_S^1, D_S^2 , and $D_{S,x}$ respectively in the ordering L .

Lemma 6.11. *Given an instance $\text{SC}(\mathcal{U}, \mathcal{F})$, let G be the graph $f(\mathcal{U}, \mathcal{F})$ (Definition 6.8), and let \mathbf{EG}_x be an induced subgraph of G as in Definition 6.7 for some $x \in \mathcal{U}$. If $\exists L$ such that $\text{wscore}_c(\mathbf{EG}_x, L) \leq t$, then there exists L' with $\text{wscore}_c(\mathbf{EG}_x, L') \leq \text{wscore}_c(\mathbf{EG}_x, L)$ such that*

1. $L'(d_1) < L'(v_S^1) \forall d_1 \in D_S^1$,
2. $L'(d_2) < L'(v_S^2) \forall d_2 \in D_S^2$, and

3. $L'(d) < L'(p_{S,x}^1) \forall d \in D_{S,x}$.

Proof. Let D be the relevant clique (D_S^1 , D_S^2 , or $D_{S,x}$) and v be the relevant vertex (v_S^1 , v_S^2 , or $p_{S,x}^1$). In any of the three cases, the vertices in D only have edges to v . The first vertex from $\{v\} \cup D$ in L will be able to reach all other vertices in the clique, and so we can choose any of these vertices first WLOG. Assuming that the ordering of the other elements is fixed relative to v , then the first vertex will also be able to reach the same subset of vertices unless v is the first vertex. However, since all other vertices in D require an additional step traversing to v first, v can reach at least as many other vertices outside of the clique. Furthermore, if v is last, then no vertex from D is reachable from another vertex not in D . While neither of these guarantee that $\text{wscore}_c(\mathbf{EG}_x, L)$ decreases, both ensure that it will not increase meaning that it is safe to put v last. \square

This property allows us to assume that D_S^1 , D_S^2 , and $D_{S,x}$ appear at the beginning of an optimal ordering. This is because the set of vertices weakly c -reachable from a vertex in the clique D only depends on the location of v in the ordering. Furthermore, since v is last in the ordering, no other vertex can reach a vertex in the clique. Thus, the placement of the clique does not affect the set of weakly c -reachable vertices from a vertex outside a clique.

Given this assumption, next we argue that v_S^1 must come before v_S^2 in the ordering for all S that contain x due to the sizes of D_S^1 and D_S^2 .

Lemma 6.12. *Given an instance $\text{SC}(\mathcal{U}, \mathcal{F})$, let G be the graph $f(\mathcal{U}, \mathcal{F})$ (Definition 6.8), and let \mathbf{EG}_x be an induced subgraph of G as in Definition 6.7 for some $x \in \mathcal{U}$. If L is an ordering on the vertices of \mathbf{EG}_x such that $\text{wscore}_c(\mathbf{EG}_x, L) \leq t$, then $L(v_S^1) < L(v_S^2)$ for all S that contain x .*

Proof. Assume $L(v_S^1) > L(v_S^2)$ for some S that contains x . Consider d , the first vertex from D_S^2 in L . Then, $|\text{wreach}_c(\mathbf{EG}_x, L, d)| \geq t + 1$ since all t other vertices in D_S^2 and v_S^1 are weakly c -reachable from d , a contradiction. \square

We apply similar reasoning for the path vertices $p_{S,x}^1 \dots p_{S,x}^\ell$ and the vertices in D_x to v_S^1 .

Lemma 6.13. *Given an instance $\text{SC}(\mathcal{U}, \mathcal{F})$, let G be the graph $f(\mathcal{U}, \mathcal{F})$ (Definition 6.8), and let \mathbf{EG}_x be an induced subgraph of G as in Definition 6.7 for some $x \in \mathcal{U}$. If L is an ordering on the vertices of \mathbf{EG}_x satisfying $\text{wscore}_c(\mathbf{EG}_x, L) \leq t$, then for each v_S^1 in \mathbf{EG}_x , $L(u) < L(v_S^1)$ for all $u \in \{D_x \cup p_{S,x}^1 \cup \dots \cup p_{S,x}^\ell\}$.*

Proof. Suppose $u \in \{D_x \cup p_{S,x}^1 \cup \dots \cup p_{S,x}^\ell\}$ and $L(u) > L(v_S^1)$. Furthermore, assume WLOG that u is the last such vertex in L . The vertex u must be weakly c -reachable from v_S^1 since u is distance at most $\ell + 1 < c$ away from v_S^1 and all other vertices on the path must be ordered before u by our selection of u . Let w be the first vertex in L from D_S^1 . Then $|\text{wreach}_c(\mathbf{EG}_x, L, w)| \geq t + 1$ since it can reach $t - 2$ vertices in D_S^1 as well as v_S^1 and v_S^2 by Lemma 6.12, and also u . Therefore, no such u can exist. \square

It now suffices to consider whether D_x and $p_{S,x}^1 \dots p_{S,x}^\ell$ can be ordered without exceeding t weakly c -reachable vertices from any vertex. The following lemma establishes that there is no way to do this.

Lemma 6.14. *Given an instance $\text{SC}(\mathcal{U}, \mathcal{F})$, let G be the graph $f(\mathcal{U}, \mathcal{F})$ (Definition 6.8), and let \mathbf{EG}_x be an induced subgraph of G as in Definition 6.7 for some $x \in \mathcal{U}$. Then $\text{wcol}_c(\mathbf{EG}_x) > t$.*

Proof. Assume $\text{wcol}_c(\mathbf{EG}_x) \leq t$, and let the ordering L be a witness. Since L must satisfy $\text{wscore}_c(\mathbf{EG}_x, L) \leq t$, we use Lemmas 6.11, 6.12, and 6.13. Consider u , the first vertex in L from D_x . If u comes before $p_{S,x}^1$ for all S , then $|\text{wreach}_c(\mathbf{EG}_x, L, u)| \geq t + 1$ since it can reach $t - 3 \cdot f_x + 1$ vertices in D_x , f_x in each of $p_{S,x}^1$, f_x in each of v_S^1 , and f_x in each of v_S^2 . Thus, w , the first $p_{S,x}^1$ in L , must come before u in L . Let d be the first vertex from D_w . Then, $|\text{wreach}_c(\mathbf{EG}_x, L, d)| \geq t + 1$ since d can reach at least $f_x - 1$ vertices in D_w , w itself, $t - 3 \cdot f_x + 1$ vertices in D_x , f_x in each of v_S^1 , and f_x in each of v_S^2 . Thus, L cannot exist and $\text{wcol}_c(\mathbf{EG}_x) > t$. \square

Lemma 6.15. *Suppose G is a graph constructed using the function f defined in Definition 6.8 applied to the SET COVER instance $(\mathcal{U}, \mathcal{F})$. Then $\text{wcol}_c(G) > t$.*

Proof. Lemma 6.15 follows directly from Lemma 6.14 and Corollary 6.10. \square

Now, we show that a solution to the SET COVER instance $(\mathcal{U}, \mathcal{F})$ can be recovered from an edit set to the t -BWE- c instance $G = f(\mathcal{U}, \mathcal{F})$ using the function g . We do this by first constructing a canonical solution and then converting to a SET COVER solution using a bijective mapping. The definition of a canonical solution depends on the edit operation.

Definition 6.9. *A solution y' to t -BWE-V- c is **canonical** if $y' \subseteq \{v_S^1 : S \in \mathcal{F}\}$. A solution y' to t -BWE-E- c or t -BWE-C- c is canonical if $y' \subseteq \{e = (v_S^1, v_S^2) : S \in \mathcal{F}\}$.*

Canonical solutions all use the same ordering L to exhibit bounded weak c -coloring number. We define that ordering here for convenience in later proofs, starting with the order on a single element gadget.

Lemma 6.16. *Given an instance $\text{SC}(\mathcal{U}, \mathcal{F})$, let G be the graph $f(\mathcal{U}, \mathcal{F})$ (Definition 6.8), and let \mathbf{EG}_x be an induced subgraph of G as in Definition 6.7 for some $x \in \mathcal{U}$. Let \hat{y} be a canonical solution to t -BWE- c (Definition 6.9). Suppose that x is contained in the sets $S_i \dots S_j$. Let L be the following ordering:*

$$D_{S_i}^1 \dots D_{S_j}^1, D_{S_i}^2 \dots D_{S_j}^2, D_{S_i,x} \dots D_{S_j,x}, D_x, p_{S_i,x}^\ell \dots p_{S_j,x}^\ell, \dots, p_{S_i,x}^1 \dots p_{S_j,x}^1, v_{S_i}^1 \dots v_{S_j}^1, v_{S_i}^2 \dots v_{S_j}^2.$$

Then $\text{wscore}_c(\mathbf{EG}_x \setminus \hat{y}, L) \leq t$.

Proof. Note that $\mathbf{EG}_x \cap y'$ must be non-empty for any solution y' . Otherwise, by Lemma 6.14, $\text{wcol}_c(\mathbf{EG}_x \setminus y') > t$, and so by Corollary 6.10, $\text{wcol}_c(G \setminus y') > t$, a contradiction.

From left to right, we show that $|\text{wreach}_c(\mathbf{EG}_x \setminus \hat{y}, L, u)| \leq t$ for each vertex u . There is some $u \in D_{S_i}^1$ that can reach $t - 2$ other vertices in $D_{S_i}^1$. However, since the path to all other vertices in \mathbf{EG}_x goes through $v_{S_i}^1$, only $v_{S_i}^1$ and $v_{S_i}^2$ will be reachable from u . Note here that no $v_{S_a}^1$ can reach any other $v_{S_b}^1$ since the shortest path between them has length $2 \cdot \ell + 2 \geq c + 1$. This also precludes u from reaching any vertex w in some other D_S^1 . Thus, u can only reach t vertices.

Similar logic applies to $D_{S_i}^2$. There is some $u \in D_{S_i}^2$ that can reach $t - 1$ other vertices in $D_{S_i}^2$. Additionally, u can reach $v_{S_i}^2$ to bring the total to t . Only other v_S^2 vertices are reachable now due to the position of $v_{S_i}^2$. However, again we observe that the shortest path between any two v_S^2 vertices is longer than c .

There is also some $u \in D_{S_i,x}$ which can reach $f_x - 1$ other vertices. Again, every path exiting $D_{S_i,x}$ uses $p_{S_i,x}^1$ and so only vertices after $p_{S_i,x}^1$ will be reachable from u . In fact, u can reach every vertex after $p_{S_i,x}^1$. However, there are only $3 \cdot f_x$ such vertices. Thus, u can reach a total of $4 \cdot f_x - 1 < t$ vertices.

Let u be the first vertex from D_x in the ordering L . Then u can reach $t - 3 \cdot f_x + 1$ other vertices in D_x . It can also reach the first vertex on each of the f_x paths. Because $p_{S,x}^1$ comes after

$p_{S,x}^2 \cdots p_{S,x}^\ell$, u cannot reach any other path vertex. Additionally, u will be able to reach every v_S^1 and every v_S^2 assuming that $c \geq 3$. Superficially, this seems to result in $|\text{wreach}_c(\text{EG}_x \setminus y', L, u)| = t + 1$. However, since $\text{EG}_x \cap \hat{y}$ must be non-empty, this cannot be the case. In the case of vertex deletion, at least one v_S^1 must be in \hat{y} , and so there are only $(f_x - 1) v_S^1$ vertices that are weakly c -reachable. Likewise, in the case of edge deletion and contraction, at least one edge connecting v_S^1 to v_S^2 must be in \hat{y} and so there are only $(f_x - 1) v_S^2$ vertices that are weakly c -reachable. Note that D_S^2 contains v_S^1 after the edge is contracted, but this does not affect the number of vertices weakly c -reachable from inside D_S^2 .

Consider $u = p_{S_i,x}^\ell$ next. The vertex u can reach at most every v_S^1 , v_S^2 , and $p_{S,x}^1$ for a total of $3 \cdot f_x$. Additionally, it can reach every vertex on its own path for another $\ell - 2$ vertices (since it cannot count itself and we already counted $p_{S_i,x}^1$). The vertex u cannot reach any vertex on another path since the unique path between them in EG_x goes through both $p_{S,x}^1$ vertices. Thus, u can reach $3 \cdot f_x + \ell - 2 \leq t$ vertices.

Lastly, we note again that there are at most t vertices after $p_{S_i,x}^1$. Therefore, no vertex appearing after $p_{S_i,x}^1$ can reach more than t other vertices by definition. \square

Since the same analysis applies to every element gadget, this shows that $\text{wcol}_c(\text{EG}_x \setminus \hat{y}) \leq t$ for all $x \in \mathcal{U}$. We use this result to produce an ordering for the vertices of the entire graph.

Lemma 6.17. *Given an instance $\text{SC}(\mathcal{U}, \mathcal{F})$, let G be the graph $f(\mathcal{U}, \mathcal{F})$ (Definition 6.8). Let \hat{y} be a canonical solution to t -BWE- c (Definition 6.9). Let L_x be the ordering for EG_x given by Lemma 6.16 for each $x \in \mathcal{U}$, and let L'_x be the ordering of the vertices produced from L_x by excluding the vertices that are not unique to a single EG_x subgraph (specifically v_S^1 , v_S^2 , D_S^1 , and D_S^2). Let L be the following ordering: $D_{S_1}^1 \cdots D_{S_m}^1, D_{S_1}^2 \cdots D_{S_m}^2, L'_{x_1} \cdots L'_{x_n}, v_{S_1}^1 \cdots v_{S_m}^1, v_{S_1}^2 \cdots v_{S_m}^2$. Then $\text{wscore}_c(G \setminus \hat{y}, L) \leq t$.*

Proof. We refer to Lemma 6.16 for the analysis of vertices in D_S^1 or D_S^2 . The same analysis applies since again it is true that the shortest path from $v_{S_a}^1$ to $v_{S_b}^2$ is longer than c . Thus, we need only show that $\text{wreach}_c(G \setminus \hat{y}, L, u) = \text{wreach}_c(\text{EG}_x \setminus \hat{y}, L_x, u)$ for every $u \in L'_x$ for every $x \in \mathcal{U}$. By Lemma 6.16, we know that $|\text{wreach}_c(\text{EG}_x \setminus \hat{y}, L_x, u)| \leq t$, and so this shows that $\text{wscore}_c(G \setminus \hat{y}, L) \leq t$.

Take u from L'_i and w from L'_j . All paths from u to w must pass through at least one $v_{S_i}^1$. Note that in order for the path to have length less than c , it can pass through at most one. However, since $v_{S_i}^1$ comes after both u and w in L , neither can reach the other. Thus, the reachability of u in EG_x with respect to L_x is identical to its reachability in G with respect to L . \square

In order to define the function g , we must first show that any solution y' to t -BWE- c can be converted to a canonical solution \hat{y} .

Lemma 6.18. *Given an instance $\text{SC}(\mathcal{U}, \mathcal{F})$, let G be the graph $f(\mathcal{U}, \mathcal{F})$ (Definition 6.8), and let y' be an edit set consisting of either vertex deletions, edge deletions, or edge contractions such that $\text{wcol}_c(G \setminus y') \leq t$. There exists a canonical solution \hat{y} such that $\text{Cost}(\hat{y}) \leq \text{Cost}(y')$.*

Proof. Construct \hat{y} in the following manner. For t -BWE-V- c , set $\hat{y} = y' \cap \{v_S^1 : S \in \mathcal{F}\}$. Additionally, if y' contains v_S^2 but not v_S^1 for some $S \in \mathcal{F}$, then add v_S^1 to \hat{y} as well. For t -BWE-E- c and t -BWE-C- c , set $\hat{y} = y' \cap \{e = (v_S^1, v_S^2) : S \in \mathcal{F}\}$. Now, we consider EG_x for each $x \in \mathcal{U}$. By Lemma 6.9 and the fact that y' is a solution, $\text{wcol}_c(\text{EG}_x \setminus y') \leq t$. In conjunction with Lemma 6.14, this shows that $y' \cap \text{EG}_x$ must be non-empty. If $\hat{y} \cap \text{EG}_x$ is empty, then we add any vertex from $\{v_S^1 : x \in S\}$ or any edge from $\{e = (v_S^1, v_S^2) : x \in S\}$ to \hat{y} depending on the problem. The intersection of \hat{y} and EG_x can only be empty when y' does not contain any edits in $\{v_S^1 : x \in S\}$ and $\{v_S^2 : x \in S\}$ or $\{e = (v_S^1, v_S^2) : x \in S\}$ depending on the edit operation. Thus, $y' \cap \text{EG}_x$ must contain an edit that is not added to \hat{y} , and so \hat{y} must be smaller than y' . \square

Mapping a graph edit set to a SET COVER solution.

Definition 6.10. *Given an instance $\text{SC}(\mathcal{U}, \mathcal{F})$, let G be the graph $f(\mathcal{U}, \mathcal{F})$ (Definition 6.8). Suppose y' is a solution to the t -BWE- c instance G . The function g converts y' to a canonical solution \hat{y} and then produces either the set $\{S : v_S^1 \in \hat{y}\}$ for an instance of t -BWE-V- c or the set $\{S : e = (v_S^1, v_S^2) \in \hat{y}\}$ for an instance of t -BWE-E- c or t -BWE-C- c using a bijective mapping between canonical edit sets and set covers.*

Clearly, these sets can be computed in polynomial time from a canonical solution. Furthermore, the canonical solution can be computed in polynomial time as described in Lemma 6.18, and so g is polynomial time computable. In order to prove that the functions f and g satisfy the necessary requirements for a strict reduction, we must show that g produces valid set covers.

Lemma 6.19. *Given an instance $\text{SC}(\mathcal{U}, \mathcal{F})$, let G be the graph $f(\mathcal{U}, \mathcal{F})$ (Definition 6.8), and let y' be a solution to the t -BWE- c instance G . Then $g(y')$ is a solution to $\text{SC}(\mathcal{U}, \mathcal{F})$.*

Proof. Suppose \hat{y} is a canonical edit set found by applying Lemma 6.18 to y' . Since each edit in \hat{y} corresponds to a chosen set in $g(\hat{y})$, the edit in $\hat{y} \cap \text{EG}_x$ corresponds to a set $S \in \mathcal{F}$ that covers x . By Lemma 6.9 and the fact that \hat{y} is a solution for t -BWE- c on G , we know that $\hat{y} \cap \text{EG}_x$ is non-empty for all $x \in \mathcal{U}$. Thus, for all $x \in \mathcal{U}$, $\exists S \in \mathcal{F} : S \in g(\hat{y})$. \square

Strict reduction from SET COVER.

Lemma 6.20. *Given an instance $\text{SC}(\mathcal{U}, \mathcal{F})$, let $G = f(\mathcal{U}, \mathcal{F})$ (Definition 6.8). Then for any solution y' to t -BWE- c on G , $\text{Cost}(y') \geq \text{Cost}(\hat{y}) = \text{Cost}(g(\hat{y}))$, where \hat{y} is the canonical solution corresponding to y' (Definition 6.9).*

Proof. Lemma 6.18 shows that $\text{Cost}(y') \geq \text{Cost}(\hat{y})$. By Definition 6.10, $\text{Cost}(\hat{y}) = \text{Cost}(g(\hat{y}))$. \square

Lemma 6.21. *Given an instance $\text{SC}(\mathcal{U}, \mathcal{F})$, let G be the graph $f(\mathcal{U}, \mathcal{F})$ (Definition 6.8), $\text{OPT}_{t\text{-BWE-}c}$ be the weight of the optimal solution to the t -BWE- c instance G , and let OPT_{SC} be the weight of the optimal solution to $\text{SC}(\mathcal{U}, \mathcal{F})$. Then $\text{OPT}_{t\text{-BWE-}c} \leq \text{OPT}_{\text{SC}}$.*

Proof. Let y^* be an optimal solution to the $\text{SC}(\mathcal{U}, \mathcal{F})$. Using the bijective mapping g described in Definition 6.10, we can find a canonical edit set \hat{y} from y^* . By Lemmas 6.9 and 6.17, we know that \hat{y} is a solution to the t -BWE- c instance G if and only if $\hat{y} \cap \text{EG}_x$ is non-empty for all $x \in \mathcal{U}$, and this is implied by y^* being a solution to the $\text{SC}(\mathcal{U}, \mathcal{F})$. By Definition 6.10, $\text{Cost}(\hat{y}) = \text{OPT}_{\text{SC}}$, and furthermore, $\text{OPT}_{t\text{-BWE-}c} \leq \text{Cost}(y')$ for any potential solution y' including \hat{y} . \square

Corollary 6.22. *Given an instance $\text{SC}(\mathcal{U}, \mathcal{F})$, let G be the graph $f(\mathcal{U}, \mathcal{F})$ (Definition 6.8), $\text{OPT}_{t\text{-BWE-}c}$ be the weight of the optimal solution to the t -BWE- c instance G , and let OPT_{SC} be the weight of the optimal solution to $\text{SC}(\mathcal{U}, \mathcal{F})$. Then $\text{OPT}_{t\text{-BWE-}c} = \text{OPT}_{\text{SC}}$.*

Proof. Using the notation of the previous proof, assume that there is another solution y' for the t -BWE- c instance G so that $\text{Cost}(y') < \text{Cost}(\hat{y})$. Then by Lemmas 6.20 and 6.21, $\text{Cost}(g(y')) \leq \text{Cost}(y') < \text{Cost}(\hat{y}) \leq \text{Cost}(y^*)$. This is a contradiction to the assumption that y^* was an optimal solution to the SET COVER instance $(\mathcal{U}, \mathcal{F})$, and so \hat{y} must be optimal. \square

Proof of Theorem 6.7. Adapting the proof of Lemma 6.8 to the case that the instance $\text{SC}(\mathcal{U}, \mathcal{F})$ is actually an instance of k -USC, i.e. every element $x \in \mathcal{U}$ has the same frequency $f_x = k$, we get that

the size of the graph in our reduction is

$$\begin{aligned} n &= |\mathcal{F}|(2t+1) + \sum_{x \in \mathcal{U}} (f_x^2 + (\ell-3)f_x + t + 2) \\ &= (2t+1)|\mathcal{F}| + |\mathcal{U}|(k^2 + (\ell-3)k + t + 2) \end{aligned} \tag{8}$$

$$= \Theta(|\mathcal{U}| \cdot (k^2 + t)), \tag{9}$$

where the last inequality follows from Theorem 3.7 on instances where $|\mathcal{F}| \leq |\mathcal{U}|$. Hence, the functions f and g run in polynomial time, and so by Lemma 6.20 and Corollary 6.22, we have demonstrated a strict reduction from k -USC.

Note that in the graphs we construct, we require $t \geq \max\{4 \cdot f_{\max}, \ell + 3 \cdot f_{\max} - 2\}$, and in particular for a fixed c (and therefore fixed $\ell = \lfloor c/2 \rfloor$) and an instance of k -USC we can set $t = 4 \cdot k$. Thus, an $o(t)$ approximation for t -BWE- c would yield an $o(k)$ approximation for SC. Hence, by Theorem 3.6 it is NP-hard to approximate t -BWE- c within a factor of $o(t)$. Note this specifically applies for k constant with respect to $|\mathcal{U}|$ and therefore $t = 4k$ constant with respect to n , by Equation (8). Furthermore, we note that because Theorem 3.6 requires $k \geq 3$ and our reduction requires $t \geq 4 \cdot f_{\max}$, $t \geq \ell + 3 \cdot f_{\max} - 2$, our reduction applies only when $t \geq \max\{12, \ell + 7\}$.

Finally, using Theorem 3.7 we can obtain a similar result for super-constant values of t assuming $\text{NP} \not\subseteq \text{DTIME}(n^{O(\log \log n)})$. Since $t = 4k$ in our reduction from k -USC and $|\mathcal{U}| \leq n$ by Equation (8), by Theorem 3.7 there is a constant $b > 0$ such that there is no $o(t)$ -approximation for any $t/4 = k \leq (\log |\mathcal{U}|)^{1/b} \leq (\log n)^{1/b}$. \square

Handling the case $c = 2$.

We now show inapproximability results for t -BOUNDED WEAK c -COLORING NUMBER EDITING when $c = 2$ by using a modification of the reduction described for $c > 2$.

Theorem 6.23. *For $c = 2$ and constant $t \geq 9$, t -BOUNDED WEAK c -COLORING NUMBER VERTEX-DELETION is $o(t)$ -inapproximable. Furthermore, there exists a constant $b > 0$ such that t -BWE-V- c is $o(t)$ -inapproximable for $t \in O(\log^{1/b} n)$, unless $\text{NP} \subseteq \text{DTIME}(n^{O(\log \log n)})$.*

Proof. For t -BWE-V-2, we change the graph construction as follows. We replace each set gadget with a simpler construction in which D_S^2 is removed from SG_S for all $S \in \mathcal{F}$. We set $|D_S^1| = t + 1$, $|D_x| = t - 2 \cdot f_x + 2$, and let $t \geq 3 \cdot f_{\max}$. Note that since $c = 2$ we have $\ell = 1$, and so t satisfies $t \geq 3 \cdot f_{\max}$ and $t \geq \ell + 2 \cdot f_{\max} - 2$.

The result of these modifications is that the graph G produced from k -USC(\mathcal{U}, \mathcal{F}) has size equal to

$$\begin{aligned} n &= |\mathcal{F}|(t+1) + \sum_{x \in \mathcal{U}} (f_x^2 - f_x + t + 2) \\ &= (t+1)|\mathcal{F}| + |\mathcal{U}|(k^2 - k + t + 2) \end{aligned} \tag{10}$$

$$= \Theta(|\mathcal{U}| \cdot k^2), \tag{11}$$

where the last equality follows from the assumption that $|\mathcal{F}| \leq |\mathcal{U}|$ given in Theorem 3.7. Hence, the functions f and g can be computed in polynomial time, and so by Lemma 6.20 and Corollary 6.22, we have again demonstrated a strict reduction from k -USC.

Note that in the graphs we construct, we require $t \geq 3 \cdot f_{\max}$, so for a fixed instance of k -USC we can set $t = 3 \cdot k$. Thus, an $o(t)$ approximation for t -BWE-V- c when $c = 2$ would yield an $o(k)$ approximation for k -USC. Hence, by Theorem 3.6 it is NP-hard to approximate t -BWE-V- c within a factor of $o(t)$ when $c = 2$. Note this specifically applies for k constant with respect to $|\mathcal{U}|$ and

therefore $t = 3k$ constant with respect to n , by Equation (8). We note that because Theorem 3.6 requires $k \geq 3$ and our reduction requires $t \geq 3 \cdot f_{\max}$, this reduction applies only when $t \geq 9$.

Finally, using Theorem 3.7 we can obtain a similar result for super-constant values of t assuming $\text{NP} \not\subseteq \text{DTIME}(n^{O(\log \log n)})$. Since $t = 3k$ in our reduction from k -USC and $|\mathcal{U}| \leq n$ by Equation (10), by Theorem 3.7 there is a constant $b > 0$ such that there is no $o(t)$ -approximation for any $t/3 = k \leq (\log |\mathcal{U}|)^{1/b} \leq (\log n)^{1/b}$. □

Theorem 6.24. *t -BWE-E- c and t -BWE-C- c are $o(\log n)$ -inapproximable when $c = 2$ and $t \in \Omega(n^{1/2})$.*

Proof. For edge deletion and contraction with $c = 2$, we change the graph construction as follows. From each element gadget \mathbf{EG}_x , we remove both the path $p_{S,x}^j$ and the clique $D_{S,x}$ for every set S that contains element x . To reconnect the graph, we add edges from each vertex in D_x directly to v_S^1 in each set gadget that \mathbf{EG}_x contains. Additionally, we set $|D_x| = t - 2 \cdot f_x + 2$, then set t to any integer $\geq \max\{2 \cdot f_{\max}, |\mathcal{F}|\}$. The constraint $t \geq 2 \cdot f_{\max}$ guarantees that there is a vertex in each D_x , since we set $|D_x| = t - 2 \cdot f_x + 2$.

The bound $t \geq |\mathcal{F}|$ is more complicated to justify. Note that, due to the removal of $p_{S,x}^1$, the length of the path between $v_{S_i}^1$ and $v_{S_j}^1$ for each pair $S_i, S_j \in \mathcal{F}$ is no longer greater than c . To prevent any v_S^1 from being able to reach too many other nodes, we pick an ordering and use it to determine the size of D_S^1 and D_S^2 for each $S \in \mathcal{F}$. For each set S , let $N_S \subseteq \mathcal{F}$ be the collection of sets that share an element with S and appear after S in the ordering. Note that v_T^1 is reachable from v_S^1 for all $T \in N_S$. Thus, we set $|D_S^1| = t - |N_S|$ and $|D_S^2| = t - |N_S| + 1$. Since $|N_S|$ could be as large as $|\mathcal{F}| - 1$, we require $t \geq |\mathcal{F}|$ so that $|D_S^1| \geq 1$ for all $S \in \mathcal{F}$.

Next we derive the size n of the graph. For each element x , the graph contains a clique D_x of size $t - 2 \cdot f_x + 2$. For each set S , the set gadget \mathbf{SG}_S has $|D_S^1| + |D_S^2| \leq 1 + 2(t - |N_S|)$ nodes, which is at most $2t$. Thus, we have

$$\begin{aligned} n &= \sum_{x \in \mathcal{U}} |D_x| + \sum_{S \in \mathcal{F}} |\mathbf{SG}_S| \\ &\leq \sum_{x \in \mathcal{U}} (t - 2 \cdot f_x + 2) + \sum_{S \in \mathcal{F}} 2t, \end{aligned}$$

which is bounded above by $t|\mathcal{U}| + 2t|\mathcal{F}|$, since $(t - 2 \cdot f_x + 2) \geq t$. Finally, since we can choose any $t \geq \max\{2 \cdot f_{\max}, |\mathcal{F}|\}$, we set $t = 2|\mathcal{F}|$ so that $n = O(2|\mathcal{F}||\mathcal{U}| + 4|\mathcal{F}|^2)$.

By Theorem 3.4, it is NP-hard to approximate $\text{SC}(\mathcal{U}, \mathcal{F})$ within a factor of $(1 - \varepsilon)(\ln |\mathcal{U}|)$ for any $\varepsilon > 0$, even for instances where $|\mathcal{F}|$ is bounded by a polynomial in $|\mathcal{U}|$, so we can assume $|\mathcal{F}| \leq |\mathcal{U}|^s$ for some constant $s \in \mathbb{N}^+$. Thus, by Lemma 6.8, the graph G has $O(|\mathcal{U}|^{2s})$ vertices, and so by the $(1 - \varepsilon)(\ln |\mathcal{U}|)$ -inapproximability of SC, $(\log n)$ -inapproximability of t -BWE- c when $c = 2$ follows from these alternative constructions and the analysis above. However, we remark that in our reduction all instances satisfy $n \geq t \geq 2|\mathcal{F}| = \Theta(|\mathcal{U}|^s) = \Theta(n^{1/2})$, and so we can only conclude inapproximability of t -BWE-E- c and t -BWE-C- c on instances where $t \in \Omega(n^{1/2})$. □

6.3 Treewidth and Clique Number: $o(\log n)$ -Inapproximability of Vertex Editing

In this section, we address the hardness of w -TREEWIDTH VERTEX DELETION (w -TW-V) and b -CLIQUE NUMBER VERTEX DELETION (b -CN-V). In the positive direction, recent work provided

an approximation scheme for w -TREEWIDTH VERTEX DELETION and related problems where the approximation ratio depends only on the target treewidth, w , and not on $\text{tw}(G)$ [32, 34]. Our results here provide the sharpest-known *lower* bound on these approximation ratios.

Theorem 6.25. w -TREEWIDTH VERTEX DELETION (b -CLIQUE NUMBER VERTEX DELETION) is $o(\log n)$ -inapproximable when $w = \Omega(n^\delta)$ ($b = \Omega(n^\delta)$) for $\delta \geq 1/2$.

Because it is NP-hard to decide whether a graph has treewidth $\leq w$ (or clique number $\leq b$), it is trivially hard to guarantee a finite approximation ratio for editing to the class. By contrast, our hardness-of-approximation results apply when editing graphs that are far from the desired class, which is the most favorable scenario for approximation.

Reduction strategy. Our proof relies on a strict reduction from SET COVER. We construct a graph G that encodes an instance $\text{SC}(\mathcal{U}, \mathcal{F})$ such that a solution to w -TW-V (or b -CN-V) on G can be mapped to a solution for $\text{SC}(\mathcal{U}, \mathcal{F})$. Intuitively, G consists of a set of outer cliques that overlap with parts of a single “central” clique. For a given instance $\text{SC}(\mathcal{U}, \mathcal{F})$, we map each element in \mathcal{U} to an outer clique and each set in \mathcal{F} to a vertex in the central clique. We prove that reducing either treewidth or clique number in G requires deleting vertices in the central clique, and that the deleted vertices correspond to sets in \mathcal{F} that form an optimal cover of \mathcal{U} . We proceed by introducing the gadgets used in this reduction.

Mapping an instance of SET COVER to an instance of vertex deletion problems.

Definition 6.11. A *set cover gadget (scg)* for $\text{SC}(\mathcal{U}, \mathcal{F})$ is a graph $G = (V, E)$ that consists of overlapping cliques constructed as follows. For each set $S \in \mathcal{F}$ there is a corresponding vertex $v_S \in V(G)$. We call these vertices **central vertices**, and they are all connected together to form the **central clique**. For each element $x \in \mathcal{U}$ G contains an **outer clique** consisting of $|\mathcal{F}| - f_x$ **dummy vertices** as well as the f_x central vertices corresponding to the sets that contain the element x . We assume that no element is in every set $S \in \mathcal{F}$ and that each set contains at least one element.

For a visualization of Definition 6.11, see Figure 8. This construction gives us a function f that maps an instance $(\mathcal{U}, \mathcal{F})$ of SC to an instance $f(\mathcal{U}, \mathcal{F})$ of either w -TW-V or b -CN-V. In the instance $f(\mathcal{U}, \mathcal{F})$ of w -TW-V we set the target treewidth $w = |\mathcal{F}| - 2$, and for b -CN-V we set $b = |\mathcal{F}| - 1$. As we will see, this corresponds to setting the target parameter so that solving SC corresponds to reducing treewidth (clique number) by 1.

Lemma 6.26. Let $(\mathcal{U}, \mathcal{F})$ be an instance of SET COVER such that no set $S \in \mathcal{F}$ is empty or contains all of \mathcal{U} , and no element $x \in \mathcal{U}$ is contained in every set. Then the corresponding scg G from Definition 6.11 has $\text{tw}(G) = |\mathcal{F}| - 1$ and $\omega(G) = |\mathcal{F}|$.

Proof. First, note that the central clique in the construction of the set cover gadget G contains exactly $|\mathcal{F}|$ vertices, and so $\text{tw}(G) \geq |\mathcal{F}| - 1$ and $\omega(G) \geq |\mathcal{F}|$. To prove the corresponding upper bound for $\omega(G)$, we show no node is contained in a clique of size greater than $|\mathcal{F}|$. By assumption no set contains every element, and so the central clique is maximal—no outer vertex is connected to every vertex in the inner clique. On the other hand, all outer vertices have degree exactly $|\mathcal{F}| - 1$ because they are connected to only vertices in their outer clique, constructed to be size $|\mathcal{F}|$.

To prove $\text{tw}(G) \leq |\mathcal{F}| - 1$ we describe a tree decomposition $(\mathcal{Y}, T = (I, F))$ of width $|\mathcal{F}| - 1$. For each outer clique, C_i , there is a leaf node in the tree decomposition, $v(B_i) \in I$, such that the bag $B_i \in \mathcal{Y}$ contains all the vertices of C_i . Additionally, there is one node $v(B) \in I$ such that its bag $B \in \mathcal{Y}$ contains all central vertices of G . By construction, each outer clique has size $|\mathcal{F}|$, as does the central clique, proving that the width of this decomposition is in fact $|\mathcal{F}| - 1$. To see the tree decomposition is valid, first note that, by construction, every vertex and edge of G is contained in at

$$\mathcal{U} = \{ \text{a}, \text{b}, \text{c}, \text{d} \}$$

$$\mathcal{F} = \{ S_1 = \{ \text{a}, \text{b} \},$$

$$S_2 = \{ \text{b}, \text{c} \},$$

$$S_3 = \{ \text{c}, \text{d} \},$$

$$S_4 = \{ \text{a}, \text{c} \} \}$$

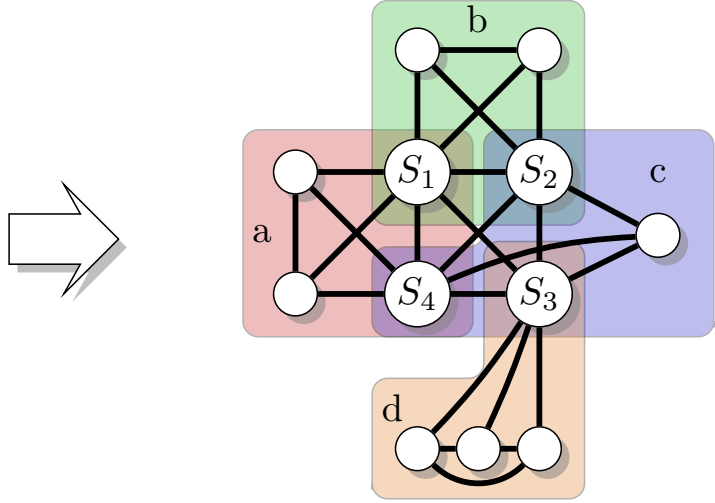

Figure 8: (*Left.*) An instance of SET COVER. (*Right.*) Our encoding of the SC instance $(\mathcal{U}, \mathcal{F})$ as a graph. Each set $S_j \in \mathcal{F}$ is mapped to a single vertex in the “central clique”. Each element is mapped to an “outer clique” (green, blue, orange, red) that contains each central vertex v_S corresponding to a set S that contains x plus $|\mathcal{F}| - f_x$ “outer vertices”, where f_x is the number of sets containing x . The unique optimal solution to the SC instance above is $\{S_1, S_3\}$. Note that the corresponding vertex deletion set consisting of the S_1 and S_3 central clique vertices is also the unique optimal solution to both 2-TW-V and 3-CN-V.

least one bag in \mathcal{Y} . Furthermore, the tree $T = (I, F)$ is a star graph with the bag B corresponding to the center of the star, $v(B)$. For any two pendant bags B_i, B_j , $B_i \cap B_j$ consists of central vertices. Since all central vertices are in B , we have that for $v \in G$, the nodes in T containing v form a connected subtree. \square

Mapping a graph deletion set to a SET COVER solution. Once a solution y' is found in scg for w -TW-V (b -CN-V), we want to map y' to a solution $g(y')$ for SC. Here, we specify such a function g by first describing how to convert an arbitrary solution to w -TW-V (b -CN-V) on G to a canonical solution.

Definition 6.12. *Given an instance $(\mathcal{U}, \mathcal{F})$ of SC, let $G = \text{scg}(\mathcal{U}, \mathcal{F})$. Given a deletion set y' in G for w -TW-V or b -CN-V, we map it to a solution $g(y')$ for SC in two steps:*

1. Construct a **canonical edit set** \hat{y} as follows: for each $v_i \in y'$ if v_i is in the central clique of G , add v_i to \hat{y} ; otherwise, choose any central vertex $v(S_j)$ in the same outer clique as v_i , and add $v(S_j)$ to \hat{y} .
2. Set $g(y') = \{S_j \in \mathcal{U} \mid v(S_j) \in \hat{y}\}$.

Note that such a central vertex $v(S_j)$ in Definition 6.12 always exists because every element $x \in \mathcal{U}$ is contained in at least one set. For our strict reduction to work we have to show that the canonical edit set \hat{y} described above is still valid for w -TW-V (b -CN-V) and that the set $g(y')$ is a valid solution to SC.

Lemma 6.27. *Let $(\mathcal{U}, \mathcal{F})$ be an instance of SET COVER, $f(\mathcal{U}, \mathcal{F})$ the corresponding instance of w -TW-V (b -CN-V), y' any solution to w -TW-V (b -CN-V) on $f(\mathcal{U}, \mathcal{F})$, and \hat{y} the canonical set described in Definition 6.12. Then \hat{y} is a valid solution to w -TW-V (b -CN-V) and $|\hat{y}| \leq |y'|$.*

Proof. To show that \hat{y} is a valid edit set, i.e., that $\text{tw}(G[V \setminus \hat{y}]) < \text{tw}(G)$, we will show that the tree decomposition of G presented in the proof of Lemma 6.26 is a valid tree decomposition of $G[V \setminus \hat{y}]$ with smaller width.

Since each bag in the tree decomposition induces a clique in G , we know that the initial solution y' necessarily contains at least one vertex from each bag—otherwise $G[V \setminus y']$ would contain a clique of size $|\mathcal{F}|$. Moreover, we know that for \hat{y} to be a valid deletion set, it suffices to show that it contains at least one vertex from each bag because then the tree decomposition bags will all have size strictly less than $|\mathcal{F}|$. For any bag, B_i , we know y' contains at least one vertex from B_i , say v_i . If this vertex is also in the central bag B , then $v_i \in \hat{y}$. Otherwise, the construction of \hat{y} selected a node $\hat{v}_i \in B_i \cap B$ to put in \hat{y} . Thus, \hat{y} contains at least one vertex from each bag, and so is a valid solution for w -TW-V. Note that this proof also shows that the solution \hat{y} is a valid solution for b -CN-V.

Finally, to show that $|\hat{y}| \leq |y'|$ observe that each element in y' corresponds to at least one element of \hat{y} . \square

Lemma 6.28. *In the notation of Lemma 6.27, $g(\hat{y})$ is a valid solution to SC, and $|g(\hat{y})| \leq |\hat{y}|$.*

Proof. Given an instance $(\mathcal{U}, \mathcal{F})$ of SC, for any $z \in \mathcal{U}$ we will show that there is some set $S_j \in g(y')$ such that $z \in S_j$. By the construction in Definition 6.11, there is an outer clique B_z in the graph G that corresponds to the element z . Any solution y' to w -TW-V (b -CN-V) necessarily must contain at least one vertex v_i in the outer clique B_z , or else $G[V \setminus y']$ would still contain a clique of size $|\mathcal{F}|$. From the construction of the set \hat{y} , we know that \hat{y} contains a vertex in B_z that is also a central vertex, call it $v(S_j)$. Hence, by the set cover gadget construction, the set S_j must contain the element z . Then $g(y')$ contains the set S_j , and so $g(y')$ is a valid set cover. Finally, since $g(y')$ has no more than one set for each vertex in \hat{y} , we have $|g(y')| \leq |\hat{y}|$. \square

Strict reduction from SET COVER. To finish our proof of a strict reduction from SC to w -TW-V (b -CN-V), we want to show that the functions f and g introduced earlier satisfy the sufficient conditions given in Section 3.3. From Lemma 6.27 and Lemma 6.28 we have the following.

Corollary 6.29. *In the notation of Lemma 6.27, $\text{Cost}_{SC}(g(y')) \leq \text{Cost}_{TW,CN}(y')$.*

Lemma 6.30. *In the notation of Lemma 6.27, $\text{OPT}_{TW,CN}(f(\mathcal{U}, \mathcal{F})) = \text{OPT}_{SC}(\mathcal{U}, \mathcal{F})$.*

Proof. Given a set cover gadget G corresponding to instance $(\mathcal{U}, \mathcal{F})$ of SC, let y^* be any optimal solution on G to w -TW-V (b -CN-V). Then by Lemma 6.27, $\text{OPT}_{TW,CN}(f(\mathcal{U}, \mathcal{F})) \geq |y^*| \geq |\hat{y}| = |g(\hat{y})| \geq \text{OPT}_{SC}(\mathcal{U}, \mathcal{F})$.

On the other hand, given any solution y to $\text{SC}(\mathcal{U}, \mathcal{F})$, the set $\hat{y} = \{v(S_j) \mid S_j \in y\}$ is a valid solution for w -TW-V (b -CN-V), and so we have $\text{OPT}_{TW,CN}(f(\mathcal{U}, \mathcal{F})) \leq \text{OPT}_{SC}(\mathcal{U}, \mathcal{F})$. \square

Proof of Theorem 6.25. The graph scg consists of $|\mathcal{F}|$ central vertices, along with $\sum_{x \in \mathcal{U}} (|\mathcal{F}| - f_x)$ outer vertices. Hence,

$$|V(G)| \leq |\mathcal{F}| + |\mathcal{F}||\mathcal{U}| - \sum_{x \in \mathcal{U}} f_x \leq |\mathcal{F}| + |\mathcal{F}||\mathcal{U}| - |\mathcal{U}|.$$

By Theorem 3.4, we may assume $|\mathcal{F}| \leq |\mathcal{U}|^s$ for some constant $s \in \mathbb{N}^+$. Thus, we have $n \in \Theta(|\mathcal{U}|^{s+1})$, and so the maps f and g in our reduction are polynomial time in the size of $\text{SC}(\mathcal{U}, \mathcal{F})$. Finally, the inequality in Corollary 6.29 and equation in Lemma 6.30 provide the sufficient condition for a strict reduction.

As noted above, in our reduction we have $n \in \Theta(|\mathcal{U}|^{s+1})$ for some constant $s > 0$, and so $\log n \in \Theta(\ln |\mathcal{U}|)$. Hence, an $o(\log n)$ -approximation for w -TW-V would give an $o(\ln |\mathcal{U}|)$ -approximation for SC. Finally, we note that in our reduction, $w = |\mathcal{F}| - 2$, which is $w \in \Theta(|\mathcal{U}|^s) = \Theta(n^{s/(s+1)})$, so we can only conclude inapproximability of w -TW-V on instances where $w \in \Omega(n^\delta)$ for some constant $\delta \geq 1/2$ (since $s \geq 1$). \square

6.4 Bounded Degree: $(\ln d - C \cdot \ln \ln d)$ -Inapproximability of Vertex Editing

In this section we prove $(\ln d - C \cdot \ln \ln d)$ -inapproximability of d -BOUNDED-DEGREE VERTEX DELETION (d -BDD-V), which matches the best known upper bound for this problem by Ebenlendr et al. [29]. The result follows from a strict reduction from SET COVER (SC).

Theorem 6.31. *For each integer $d \geq 1$, there exists a constant $C > 0$ such that d -BDD-V is $(\ln d - C \cdot \ln \ln d)$ -inapproximable.*

Reduction strategy. We encode an instance $\text{SC}(\mathcal{U}, \mathcal{F})$ as a bipartite graph G in which one partition represents elements in \mathcal{U} , the other partition represents sets in \mathcal{F} , and an edge between a set vertex and an element vertex indicates containment. Then we exhibit a mapping between solutions of the two problems that we show preserves solution sizes. We proceed by introducing the gadgets used in this reduction.

Mapping an instance of SET COVER to an instance of d -BOUNDED-DEGREE VERTEX DELETION.

Definition 6.13. *Given an instance $(\mathcal{U}, \mathcal{F})$ of SET COVER, we construct a **set cover graph**, scdg , as follows. Let $\Delta = \max\{|S| : S \in \mathcal{F}\}$, let f_e be the number of sets that element e appears in, and let $f_{\max} = \max\{f_e : e \in \mathcal{U}\}$. Set $d = \max\{\Delta, f_{\max}\}$. Consider the bipartite representation of $\text{SC}(\mathcal{U}, \mathcal{F})$ in which each set in \mathcal{F} and each element in \mathcal{U} is represented by a vertex, and there is an edge between the corresponding vertices of an element e and a set S if $e \in S$. Then, we augment the degree of each element vertex (e.g. v_e in Figure 9) to $d+1$ by adding dummy vertices $x_{e,1}, \dots, x_{e,d+1-f_e}$. For each element e , we define \mathbf{T}_e to be the set of vertices containing v_e , the vertices corresponding to the sets that contain e , and the dummy vertices of e .*

This construction provides a map f from an instance $\text{SC}(\mathcal{U}, \mathcal{F})$ to instance $G = f(\mathcal{U}, \mathcal{F})$ of d -BDD-V. The component \mathbf{T}_e of the gadget is visualized in Figure 9.

Mapping a graph deletion set to a SET COVER instance. Next we construct a function g that maps a solution for instance y' of d -BDD-V to a solution $g(y')$ to SC.

Definition 6.14. *Given an instance $(\mathcal{U}, \mathcal{F})$ of SC, let $G = (V, E)$ be the corresponding set cover graph constructed as in Definition 6.13, and again let $d = \max\{\Delta, f_{\max}\}$. For any fixed, arbitrary, feasible solution $y' \subset V(G)$ to d -BDD-V(G), we construct a d -BDD-V-to-SC map, g , that maps a feasible solution y' for d -BDD-V(G) to a solution $g(y')$ for $\text{SC}(\mathcal{U}, \mathcal{F})$ in two steps:*

1. Construct a **canonical edit set** \hat{y} as follows: for each $v_i \in y'$ if v_i is a set vertex for set S_j , then add v_i to \hat{y} . Otherwise it is necessarily an element vertex v_e or a dummy vertex $x_{e,j}$ for some element e ; the corresponding gadget \mathbf{T}_e must contain at least one set vertex, $v(S_j)$. Choose one such set vertex $v(S_j) \in \mathbf{T}_e$ arbitrarily and add $v(S_j)$ to \hat{y} .
2. Set $g(\hat{y}) = \{S_j \in \mathcal{U} \mid v(S_j) \in \hat{y}\}$.

Lemma 6.32. *Given an instance $(\mathcal{U}, \mathcal{F})$ of SC, let $G = (V, E)$ be the graph scdg constructed in Definition 6.13. If y' is an arbitrary feasible solution of d -BDD-V(G), then for each $e \in \mathcal{U}$, $\mathbf{T}_e \cap y'$ is non-empty.*

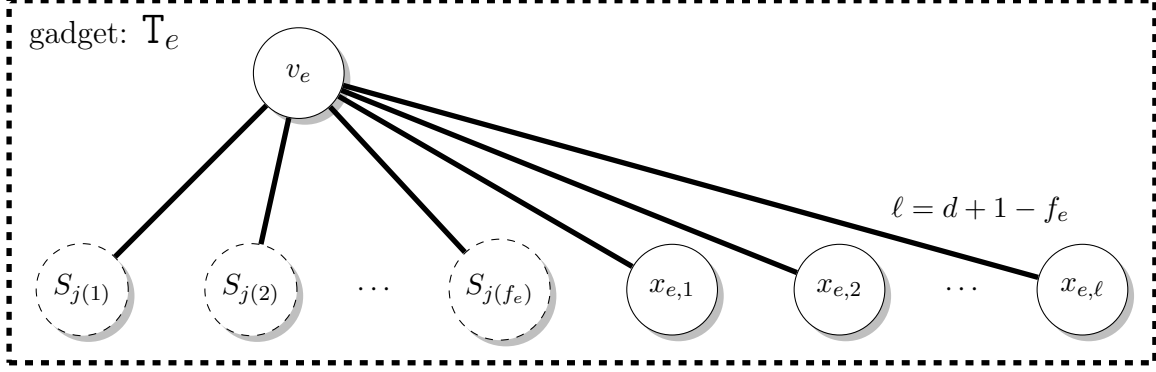

Figure 9: The gadget T_e contains element vertex v_e , the dummy vertices $(x_{e,i})$ of element e , and the set vertex of each set S_j that contains e . The indices $j(i)$ for $i = 1, \dots, f_e$ are the indices of the sets $S_{j(i)}$ that contain e . Note that for different elements e and e' , the only vertices contained in $T_e \cap T_{e'}$ are necessarily set vertices.

Proof. If $T_e \cap y' = \emptyset$ for an element e , then $\deg(v_e)$ in $G[V \setminus y']$ is $d + 1$ which contradicts the fact that y' is a feasible solution of d -BDD-V(G). \square

Lemma 6.33. *Let $G = (V, E)$ be the graph scdg for a SC instance $(\mathcal{U}, \mathcal{F})$, and $Z \subseteq V(G)$. If, for each element $e \in \mathcal{U}$, $T_e \cap Z$ contains at least one set vertex, S_j , then Z is a feasible solution of d -BDD-V(G).*

Proof. Note that, in the construction in Definition 6.13, the degree of each set vertex is at most $\Delta \leq d$ and each dummy vertex has degree exactly one. Moreover, the degree of each element vertex in G is exactly $d + 1$. Hence, if for each element e , $T_e \cap Z$ is non-empty (and in particular it contains a set vertex), then the degree of each element vertex in $G[V \setminus Z]$ is at most d , and so Z is a feasible solution. \square

Lemma 6.34. *In the notation of Definition 6.14, the canonical solution \hat{y} corresponding to a solution y' is a feasible solution to d -BDD-V(G) and satisfies $|\hat{y}| \leq |y'|$.*

Proof. Because y' is feasible, by Lemma 6.32 we know that for each $e \in \mathcal{U}$, y' contains at least one vertex $v \in T_e$. Suppose \hat{y} is not feasible. Then for some $e \in \mathcal{U}$, $T_e \cap \hat{y}$ is empty, by the contrapositive of Lemma 6.33. Since y' is feasible, there exists some $v \in T_e \cap y'$. Then by Definition 6.14, \hat{y} must contain v if v is a set vertex, or else \hat{y} must contain a set vertex in $T_e \cap y'$. This is a contradiction, so \hat{y} is feasible.

Finally, to prove that $|\hat{y}| \leq |y'|$, note that each vertex $v \in y'$ is mapped to no more than one vertex in \hat{y} in the construction in Definition 6.14. \square

Lemma 6.35. *In the notation of Definition 6.14, $g(\hat{y})$ is a feasible solution to SC(\mathcal{U}, \mathcal{F}) and satisfies $|g(\hat{y})| \leq |y'|$.*

Proof. Take any $e \in \mathcal{U}$. By Lemma 6.34 we know \hat{y} is a feasible solution to d -BDD-V(G) and so by Lemma 6.32 the set $\hat{y} \cap T_e$ is non-empty. Next, we note that by construction \hat{y} contains only set vertices, and so there is some set S_j such that $v(S_j) \in \hat{y} \cap T_e$. Then by Definition 6.14, we know $S_j \in g(\hat{y})$. This shows every element $e \in \mathcal{U}$ is covered by at least one set S_j in $g(\hat{y})$, i.e., $g(\hat{y})$ is a feasible solution to SC(\mathcal{U}, \mathcal{F}).

Finally, $g(\hat{y})$ contains no more than one set S_j for each set vertex $v(S_j)$ in \hat{y} . \square

Corollary 6.36. *In the notation of Definition 6.14, $g(\hat{y})$ satisfies $|g(\hat{y})| \leq |\hat{y}| \leq |y'|$.*

Strict reduction from SET COVER. To finish our proof of a strict reduction from SC to d -BDD-V, we want to show that the functions f and g introduced earlier in this subsection satisfy the sufficient conditions given in Definition 3.9.

Given a SC instance $(\mathcal{U}, \mathcal{F})$ and any feasible solution y' to $f(\mathcal{U}, \mathcal{F}) = d\text{-BDD-V}(G)$, by Corollary 6.36 we have that $g(\hat{y})$ is a solution to $(\mathcal{U}, \mathcal{F})$ with $|g(\hat{y})| \leq |y'|$.

Corollary 6.37. *In the notation of Definition 6.14, $\text{Cost}_{\text{SC}}(g(\hat{y})) \leq \text{Cost}_{d\text{-BDD-V}}(y')$.*

Lemma 6.38. *In the notation of Definition 6.13, $\text{OPT}_{\text{SC}}(\mathcal{U}, \mathcal{F}) = \text{OPT}_{d\text{-BDD-V}}(f(\mathcal{U}, \mathcal{F}))$.*

Proof. From Corollary 6.37, we know that if y' is optimal, then $\text{OPT}_{d\text{-BDD-V}}(f(\mathcal{U}, \mathcal{F})) = |y'|$. Since $\text{OPT}_{\text{SC}}(\mathcal{U}, \mathcal{F}) \leq |g(\hat{y})|$ by optimality, we have $\text{OPT}_{\text{SC}}(\mathcal{U}, \mathcal{F}) \leq \text{OPT}_{d\text{-BDD-V}}(f(\mathcal{U}, \mathcal{F}))$.

Conversely, given any solution \mathcal{S} to $\text{SC}(\mathcal{U}, \mathcal{F})$, let $Z \subset V(G)$ consist of each set vertex whose set is in \mathcal{S} . Then $|Z| \leq |\mathcal{S}|$, and by Lemma 6.33 we know Z is a feasible solution to $d\text{-BDD-V}(G)$. Thus, we have $\text{OPT}_{\text{SC}}(\mathcal{U}, \mathcal{F}) \geq \text{OPT}_{d\text{-BDD-V}}(f(\mathcal{U}, \mathcal{F}))$. \square

We can now prove the main theorem.

Proof of Theorem 6.31. Corollary 6.37 and Lemma 6.38 provide the approximation ratio requirements for a strict reduction given in Definition 3.9. Moreover, the mappings f and g are polynomial in $|\mathcal{U}| + |\mathcal{F}|$, and so we have demonstrated a strict reduction.

Finally, we derive a lower bound on the approximation ratio for $d\text{-BDD-V}$. Recall that $\Delta = \max_{S \in \mathcal{F}} |S|$, $f_{\max} = \max\{f_e : e \in \mathcal{U}\}$, and $d = \max\{\Delta, f_{\max}\}$. By Theorem 3.5, there exists a constant $C > 0$ such that it is NP-hard to approximate SC within a factor of $(\ln \Delta - C \cdot \ln \ln \Delta)$. Moreover, we can assume $\Delta \geq f_{\max}$ and so we can express $d = \Delta$. Thus, by our strict reduction above, it is NP-hard to approximate $d\text{-BDD-V}$ within a factor of $(\ln d - C \cdot \ln \ln d)$. \square

6.5 Treedepth 2: $(2 - \varepsilon)$ -Inapproximability of Vertex Editing

In this section, we prove the following hardness result on STAR FOREST VERTEX DELETION.

Theorem 6.39. *SF-V is $(2 - \varepsilon)$ -inapproximable assuming the Unique Games Conjecture.*

Reduction strategy. Given an instance of VC on a graph G we modify G to create an instance of SF-V $f(G)$. Then we exhibit a mapping between solutions of the two problems that we show preserves solution sizes, from which a strict reduction follows. We proceed by introducing the aforementioned mapping.

Mapping an instance of VERTEX COVER to an instance of STAR FOREST VERTEX DELETION.

Definition 6.15. *Given an instance $G = (V, E)$ of VERTEX COVER, we construct a **SF graph gadget** $G' = (V', E')$ by subdividing the edges of G once. We call the vertices in G' created by the subdivision of edges in G the **subdivision vertices**, denoted $S \subset V'$, and refer to members of V as **inherited vertices** of V' . Let $n = |V|$. To each inherited vertex in V' , we attach $(2n + 1)$ new, pendant vertices in G' , which we call the **auxiliary vertices** and denote $A \subset V'$.*

This defines a mapping $f(G) = G' = (V', E')$ (see Figure 10) where $|V'| = O(|V|^2)$ and $|E'| = O(|E| + |V|^2)$.

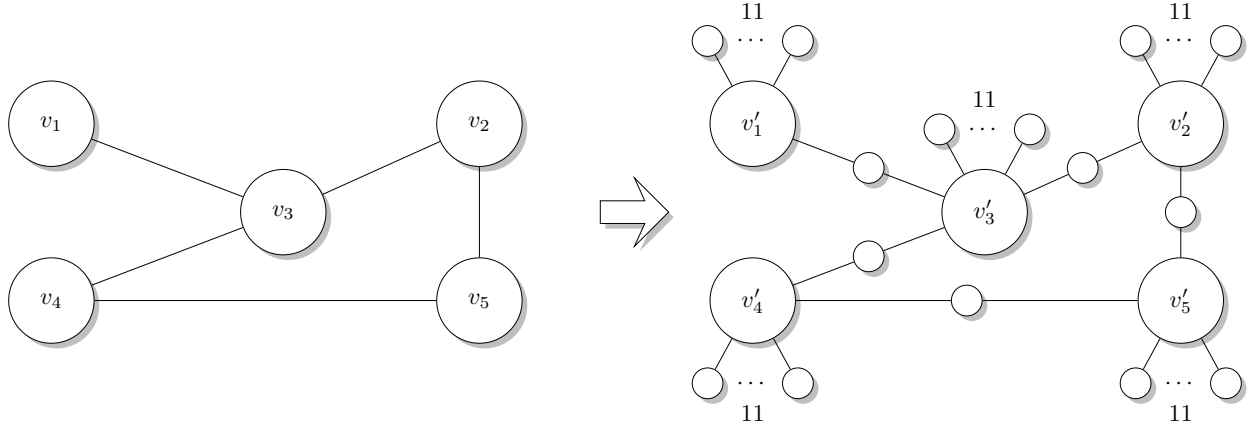

Figure 10: Given a graph $G = (V, E)$ as an instance of VERTEX COVER (*left*), we create a corresponding instance of STAR FOREST VERTEX DELETION, the graph $G' = (V', E')$ (*right*), by subdividing every edge in E and attaching $2|V| + 1$ pendants to each vertex in V .

Lemma 6.40. *Given an instance G of VC, let $f(G)$ be the SF graph gadget (Definition 6.15). Let y be any feasible solution to VC(G). Then y is a feasible solution to SF-V($f(G)$).*

Proof. We first prove that, given a solution y to VC(G), the vertex set $y' = y$ is a solution for instance SF-V($f(G)$): that is, $f(G) \setminus y'$ is a star forest.

Using the notation of Definition 6.15, for each vertex $w \in S$, since y is a vertex cover of G , deleting y from g' means at least one of the adjacent vertices to w is removed from G' . Thus, w becomes a leaf of the star graph with center given by the other vertex adjacent to w (or, if both adjacent vertices are removed, w becomes a center). For all vertices that are removed, their corresponding neighbors in A become centers. For all vertices that are not removed, the corresponding vertices in A that are attached to them are leaves. Thus, $y' = y \subset V \subset V'$ is a feasible solution to SF-V(G'). \square

Since this applies to all solutions of VC(G), in particular it applies to optimal solutions.

Corollary 6.41. *In the notation of Lemma 6.40, $\text{OPT}_{\text{VC}}(G) \geq \text{OPT}_{\text{SF-V}}(f(G))$.*

Mapping a graph deletion set to a VERTEX COVER instance.

Lemma 6.42. *Given an instance G of VC, let $G' = f(G)$ from Definition 6.15. Given an optimal solution y^* to SF-V(G'), there exists a solution $g(y^*)$ to VC(G) such that $|g(y^*)| = |y^*|$.*

Proof. Let y' be any feasible solution to SF-V on G' . Then for each vertex $v \in y'$, each vertex adjacent to v either becomes a center of a star or a leaf of a star. We will show that no optimal solution y^* for SF-V(G') contains any vertices in $S \cup A$.

To start, we show that, given a valid optimal solution y^* for SF-V(G'), we can obtain an optimal solution C for SF-V(G') where $|C| = |\text{OPT}_{\text{SF-V}}(G')|$. We note that $\text{OPT}_{\text{SF-V}}(G) \leq n$ for all G .

Suppose $y^* \cap S$ is non-empty and let $v \in y^* \cap S$. Let e_1 and e_2 be the two neighbors of v in G' . Then, both e_1 and e_2 become leaves of stars in $G'[V' - y^*]$. Assume not; then one or both of e_1 and e_2 are centers. If one of e_1 and e_2 is a leaf then we can delete it instead of v , or if they are both centers we can delete either one instead of v , resulting in no vertices from S being deleted in some optimal solution, a contradiction. Then e_1 and e_2 have degree 1 in $G'[V' - y^*]$, they must each have

degree 1. By construction of G' , e_1 and e_2 are inherited vertices; thus, each is connected to $2n + 1$ auxiliary vertices in G' . In order for e_1 and e_2 to become leaf vertices in $G'[V' - y^*]$, $4n + 2$ vertices must be deleted. Thus, there exists an optimal solution y^* to SF-V(G') such that $S \cap y^*$ is empty.

Next we show that for any optimal solution y^* to SF-V(G'), there exists another optimal solution y_2^* such that $y_2^* \cap A$ is empty. If $v \in y^*$ for some auxiliary vertex $v \in A$, then let u be the inherited vertex to which v is attached, and set $y_2^* = y^* \cup \{u\} \setminus \{v\}$. Note that y_2^* is necessarily still a feasible solution to SF-V(G'), and $|y_2^*| \leq |y^*|$.

This shows there exists an optimal solution y^* to SF-V(G') that contains only inherited vertices, i.e., $y^* \subset V$. Next we show that $C = y^*$ is a valid vertex cover of G . In order for $G'[V' - y^*]$ to be a star forest, all vertices in S must be leaves of $G'[V' - y^*]$. This means that at least one vertex adjacent to each vertex in S is in y^* . Equivalently, y^* touches every edge in G and is a solution to VC(G) with size $\text{OPT}_{\text{SF-V}}(f(G))$, as desired. \square

Note that Lemma 6.42 implies $\text{OPT}_{\text{VC}}(G) \leq \text{OPT}_{\text{SF-V}}(f(G))$, so by Corollary 6.41 we have the following.

Corollary 6.43. *In the notation of Lemma 6.40, $\text{OPT}_{\text{VC}}(G) = \text{OPT}_{\text{SF-V}}(f(G))$.*

Strict reduction from VERTEX COVER. To finish our proof of a strict reduction from VERTEX COVER to STAR FOREST VERTEX DELETION, we want to prove our reduction satisfies the sufficient conditions given in Definition 3.9, then use our reduction and Lemma 6.42 to prove the main theorem of this section.

Proof of Theorem 6.39. Let $G' = (V', E') = f(G)$ and let y' be any feasible deletion set for SF-V(G'). From y' we will construct a canonical solution \hat{y} to SF-V(G') consisting only of vertices from V , and show that \hat{y} is then a solution to VC(G).

Recall from the construction of $G' = f(G)$ that V' is partitioned into V, A , and S . Thus, the vertices in y' must fall into these three sets. For each $v \in y'$,

1. if $v \in V$ add v to \hat{y} ,
2. if $v \in A$ then $v \in N(u)$ for some $u \in V$; add u to \hat{y} .
3. if $v \in S$, then v 's two neighbors are in V ; choose one at random and add it to \hat{y} .

Note that this construction guarantees that \hat{y} contains at most one vertex for each vertex in y' , and so $|\hat{y}| \leq |y'|$. Furthermore, $\hat{y} \subseteq V$.

It remains to show that \hat{y} is a solution to VC(G). Suppose not; then $G[V \setminus \hat{y}]$ contains an edge. Let the edge have endpoints $u, v \in V \setminus \hat{y}$. Then in G' , the nodes u, v are each connected to a subdivided node, $s \in S$. Since neither u nor v is in \hat{y} , by construction u, s, v are not in y' . Moreover, the construction of \hat{y} also guarantees that, since $u, v \notin \hat{y}$, none of the auxiliary vertices attached to u, v in G' are contained in y' . This implies that $G'[V' \setminus y']$ contains vertices u, v, s , and all auxiliary vertices attached to u and v , proving that y' is not a solution to SF-V(G').

This proves $\text{Cost}_{\text{VC}}(g(y')) \leq \text{Cost}_{\text{SF-V}}(y')$, completing a strict reduction from VC to SF-V. \square

6.6 Treedepth 2: APX-hardness of Edge Editing

Here we prove that deleting *edges* to make a graph a star forest is APX-hard. We proceed via a reduction from MINIMUM DOMINATING SET- B .

Theorem 6.44. STAR FOREST EDGE DELETION is APX-complete, i.e. there exists a constant $\varepsilon > 0$ such that it is NP-hard to approximate SF-E to within a factor of $1 + \varepsilon$.

Reduction strategy. We exhibit a mapping between a solution for DSB and SF-E on the same graph, and prove the mapping meets the requirements of an L-reduction.

Mapping an instance of MINIMUM DOMINATING SET- B to an instance of STAR FOREST EDGE DELETION. Given an instance $G = (V, E)$ for MINIMUM DOMINATING SET- B , we define $f(G) = G$. To clarify when we consider G as an instance of SF-E, we refer to it as $G' = (V', E')$.

Mapping a graph deletion set to a MINIMUM DOMINATING SET- B instance. To define a map g that converts a solution y' for SF-E($f(G)$) into a solution $g(y')$ for DSB(G), first recall that for a feasible solution y' to SF-E(G'), $G'[E' \setminus y']$ is a star forest. We define $g(y')$ to be the set of centers of the stars in $G'[E' \setminus y']$, including isolates.

We now prove that g does in fact give a feasible solution to DSB(G).

Lemma 6.45. *Given an instance $G = (V, E)$ of MINIMUM DOMINATING SET- B , let $n = |V|$, $m = |E|$, and $G' = f(G)$ denote the corresponding instance of STAR FOREST EDGE DELETION. Given any feasible solution y' for SF-E(G'), $g(y')$ is a feasible solution to DSB(G) and satisfies $|g(y')| = n - m + |y'|$. In addition, given a valid dominating set $D \subseteq V$, we obtain a valid edge edit set Z for the graph G to a star forest where $|Z| = m - n + |D|$.*

Proof. Given an edge deletion set y' for SF-E(G'), $g(y')$ consists of the centers of the star graphs in $G'[E' \setminus y']$. Thus, every vertex $u \in G'[E' \setminus y']$ is in a star. If u is the center of a star, then u is in $g(y')$; otherwise, u is adjacent to a star center, v , which is necessarily in $g(y')$. Thus, the vertex set $g(y')$ dominates all vertices of $G'[E' \setminus y']$, and therefore of G .

Next, observe that the number of edges in $G'[E' \setminus y']$ is $m - |y'|$. For every vertex u in $G'[E' \setminus y']$ that is not a center, we use one edge to connect u to its center. Hence, the number of edges in $G'[E' \setminus y']$ is equal to the number of vertices which are not centers. Since $|g(y')|$ equals the number of centers exactly, we have $n - |g(y')| = m - |y'|$.

Given a dominating set D for G , every vertex in V is either in D or adjacent to a vertex in D . Thus, we can remove all edges that do not connect a vertex in $V \setminus D$ to a vertex in D . If a vertex in $V \setminus D$ is connected to more than one vertex in D , remove all but one of the edges to a vertex in D . Also remove all edges between vertices $v_1, v_2 \in V \setminus D$ and between vertices $d_1, d_2 \in D$. The remaining graph is a star forest since each vertex $v \in V \setminus D$ is connected to at most one vertex and all vertices in D are centers and are not connected to any other centers. Finally, let Z be the set of deleted edges. To see that $|D| = n - m + |Z|$, observe that $g(Z) = D$. \square

L-reduction from MINIMUM DOMINATING SET- B . To show an L-reduction from DSB to SF-E we must meet the conditions from Definition 3.8.

Lemma 6.46. *For any fixed $B > 0$, there exists a constant α such that for all degree- B bounded graphs G we have $\text{OPT}_{\text{SF-E}}(f(G)) \leq \alpha \cdot \text{OPT}_{\text{DSB}}(G)$.*

Proof. Let $G = (V, E)$ be a degree- B bounded graph and set $G' = f(G)$. Then $\text{OPT}_{\text{SF-E}}(G') \leq |E| \leq Bn/2$ and $\text{OPT}_{\text{DSB}}(G) \geq n/(B+1)$ (since each node in the dominating set can cover at most B other nodes). Therefore, any constant α satisfying the condition $\alpha \geq \frac{Bn/2}{n/(B+1)} = B(B+1)/2$ also satisfies $\text{OPT}_{\text{SF-E}}(G') \leq \alpha \cdot \text{OPT}_{\text{DSB}}(G)$. \square

Lemma 6.47. *Given an instance DSB(G), and any feasible solution y' to instance $G' = f(G)$ of SF-E, we have $\text{Cost}_{\text{DSB}}(g(y')) - \text{OPT}_{\text{DSB}}(G) = \text{Cost}_{\text{SF-E}}(y') - \text{OPT}_{\text{SF-E}}(G')$.*

Proof. For any solution y' to SF-E(G'), Lemma 6.45 yields the equations $\text{OPT}_{\text{DSB}}(G) = n - m + \text{OPT}_{\text{SF-E}}(G')$ and $\text{Cost}_{\text{DSB}}(g(y')) = n - m + \text{Cost}_{\text{SF-E}}(y')$. Combining these, we have $\text{Cost}_{\text{DSB}}(g(y')) - \text{OPT}_{\text{DSB}}(G) = \text{Cost}_{\text{SF-E}}(y') - \text{OPT}_{\text{SF-E}}(G')$, as desired. \square

Finally, we use Theorem 3.9 to complete our proof of Theorem 6.44.

Proof of Theorem 6.44. First note that the functions f and g defined earlier in this subsection give a polynomial time reduction from DSB to SF-E and satisfy the feasibility conditions of an L-reduction. Next we show f and g satisfy the approximation inequalities.

Given Lemmas 6.46 and 6.47, if SF-E can be approximated to a ratio of $1 + \varepsilon$ for some constant $\varepsilon > 0$, then we show that DSB can be approximated to a ratio of $(1 + \frac{\varepsilon B(B+1)}{2})$.

The approximation ratio for DSB is $\frac{\text{Cost}_{\text{DSB}}(g(y'))}{\text{OPT}_{\text{DSB}}(G)}$. Substituting from Lemmas 6.46 and 6.47, we obtain:

$$\begin{aligned} \frac{\text{Cost}_{\text{DSB}}(g(y'))}{\text{OPT}_{\text{DSB}}(G)} &\leq \frac{\text{OPT}_{\text{DSB}}(G) + (\text{Cost}_{\text{SF-E}}(y') - \text{OPT}_{\text{SF-E}}(G'))}{\text{OPT}_{\text{DSB}}(G)} \\ &\leq 1 + \alpha \left(\frac{\text{Cost}_{\text{SF-E}}(y') - \text{OPT}_{\text{SF-E}}(G')}{\text{OPT}_{\text{SF-E}}(G')} \right), \end{aligned}$$

which is bounded above by $1 + \varepsilon B(B + 1)/2$, proving that SF-E is APX-hard. □

7 Open Problems

We hope that our framework for extending approximation algorithms from structural graph classes to graphs near those classes, by editing to the class and lifting the resulting solution, can be applied to many more contexts. Specific challenges raised by this work include the following:

1. Editing via edge contractions. Approximation algorithms for this type of editing would enable the framework to apply to the many optimization problems closed under just contraction, such as TSP TOUR and CONNECTED VERTEX COVER.
2. Editing to H -minor-free graphs. Existing results apply only when H is planar [34]. According to Graph Minor Theory, the natural next steps are when H can be drawn with a single crossing, when H is an apex graph (removal of one vertex leaves a planar graph), and when H is an arbitrary graph (say, a clique). H -minor-free graphs have many PTASs (e.g., [20, 21]) that would be exciting to extend via structural rounding.
3. Editing to bounded clique number and bounded weak c -coloring number. While we have lower bounds on approximability, we lack good approximation algorithms.

Acknowledgments

We thank Abida Haque and Adam Hesterberg for helpful initial discussions, Nicole Wein for providing helpful references on bounded degeneracy problems, and Michael O'Brien for helpful comments on the manuscript.

This research was supported in part by the Army Research Office under Grant Number W911NF-17-1-0271 to Blair D. Sullivan, the Gordon & Betty Moore Foundation's Data-Driven Discovery Initiative under Grant GBMF4560 to Blair D. Sullivan, as well as NSF grants CCF-1161626 and IIS-1546290 to Erik D. Demaine. Timothy D. Goodrich is partially supported by a National Defense Science & Engineering Graduate Program fellowship. Quanquan Liu is partially supported by a National Science Foundation Graduate Research Fellowship under grant 1122374.

The views and conclusions contained in this document are those of the authors and should not be interpreted as representing the official policies, either expressed or implied, of the Army Research Office or the U.S. Government. The U.S. Government is authorized to reproduce and distribute reprints for Government purposes notwithstanding any copyright notation herein.

References

- [1] J. Alber and R. Niedermeier. Improved tree decomposition based algorithms for domination-like problems. In *Proceedings of the 5th Latin American Symposium on Theoretical Informatics*, pages 613–627. Springer, 2001.
- [2] E. Amir. Approximation algorithms for treewidth. *Algorithmica*, 56(4):448–479, 2010.
- [3] N. Bansal, D. Reichman, and S. W. Umboh. LP-based robust algorithms for noisy minor-free and bounded treewidth graphs. In *Proceedings of the 28th Annual ACM-SIAM Symposium on Discrete Algorithms*, pages 1964–1979. Society for Industrial and Applied Mathematics, 2017.
- [4] N. Bansal and S. W. Umboh. Tight approximation bounds for dominating set on graphs of bounded arboricity. *Information Processing Letters*, 122:21–24, 2017.
- [5] R. Bar-Yehuda, K. Bendel, A. Freund, and D. Rawitz. Local ratio: A unified framework for approximation algorithms. *ACM Computing Surveys*, 36(4):422–463, 2004.
- [6] T. Biedl, M. Chimani, M. Derka, and P. Mutzel. Crossing number for graphs with bounded pathwidth. In *28th International Symposium on Algorithms and Computation, (ISAAC)*, pages 13:1–13:13, Phuket, Thailand, December 2017.
- [7] H. L. Bodlaender. Dynamic programming on graphs with bounded treewidth. In T. Lepistö and A. Salomaa, editors, *Automata, Languages and Programming*, pages 105–118, Berlin, Heidelberg, 1988. Springer Berlin Heidelberg.
- [8] H. L. Bodlaender, J. R. Gilbert, H. Hafsteinsson, and T. Kloks. Approximating treewidth, pathwidth, frontsize, and shortest elimination tree. *Journal of Algorithms*, 18(2):238–255, 1995.
- [9] G. Borradaile and H. Le. Optimal Dynamic Program for r -Domination Problems over Tree Decompositions. In J. Guo and D. Hermelin, editors, *Proceedings of the 11th International Symposium on Parameterized and Exact Computation*, volume 63 of *Leibniz International Proceedings in Informatics (LIPIcs)*, pages 8:1–8:23, Dagstuhl, Germany, 2017. Schloss Dagstuhl–Leibniz-Zentrum fuer Informatik.
- [10] L. Cai. Parameterized complexity of vertex colouring. *Discrete Applied Mathematics*, 127(3):415–429, 2003.
- [11] T. M. Chan and S. Har-Peled. Approximation algorithms for maximum independent set of pseudo-disks. *Discrete & Computational Geometry*, 48(2):373–392, 2012.
- [12] C. Chekuri and J. Chuzhoy. Polynomial bounds for the grid-minor theorem. *Journal of the ACM*, 63(5):40:1–40:65, Dec. 2016.

- [13] C. Chekuri and A. Sidiropoulos. Approximation algorithms for Euler genus and related problems. In *Proceedings of the IEEE 54th Annual Symposium on Foundations of Computer Science*, pages 167–176. IEEE, 2013.
- [14] M. Chlebík and J. Chlebíková. Approximation hardness of dominating set problems in bounded degree graphs. *Information and Computation*, 206(11):1264–1275, 2008.
- [15] M. Chrobak and D. Eppstein. Planar orientations with low out-degree and compaction of adjacency matrices. *Theoretical Computer Science*, 86(2):243–266, 1991.
- [16] J. Chuzhoy. An algorithm for the graph crossing number problem. In *Proceedings of the 43rd Annual ACM Symposium on Theory of Computing*, pages 303–312, 2011.
- [17] J. Chuzhoy, Y. Makarychev, and A. Sidiropoulos. On graph crossing number and edge planarization. In *Proceedings of the 22nd Annual ACM-SIAM Symposium on Discrete Algorithms*, pages 1050–1069, 2011.
- [18] M. Cygan, J. Nederlof, M. Pilipczuk, M. Pilipczuk, J. M. van Rooij, and J. O. Wojtaszczyk. Solving connectivity problems parameterized by treewidth in single exponential time. In *Foundations of computer science (focs), 2011 IEEE 52nd annual symposium on*, pages 150–159. IEEE, 2011.
- [19] K. K. Dabrowski, P. A. Golovach, P. van’t Hof, D. Paulusma, and D. M. Thilikos. Editing to a planar graph of given degrees. In *Computer Science—Theory and Applications*, pages 143–156. Springer, 2015.
- [20] E. D. Demaine and M. Hajiaghayi. Bidimensionality: New connections between FPT algorithms and PTASs. In *Proceedings of the 16th Annual ACM-SIAM Symposium on Discrete Algorithms*, pages 590–601, Philadelphia, PA, USA, 2005. Society for Industrial and Applied Mathematics.
- [21] E. D. Demaine, M. Hajiaghayi, and K. Kawarabayashi. Contraction decomposition in H -minor-free graphs and algorithmic applications. In *Proceedings of the 43rd Annual ACM Symposium on Theory of Computing*, pages 441–450, 2011.
- [22] I. Dinur, V. Guruswami, S. Khot, and O. Regev. A new multilayered PCP and the hardness of hypergraph vertex cover. *SIAM Journal on Computing*, 34(5):1129–1146, 2005.
- [23] I. Dinur and S. Safra. On the hardness of approximating minimum vertex cover. *Annals of Mathematics*, pages 439–485, 2005.
- [24] I. Dinur and D. Steurer. Analytical approach to parallel repetition. In *Proceedings of the 46th Annual ACM Symposium on Theory of Computing*, pages 624–633, 2014.
- [25] R. G. Downey and M. R. Fellows. *Fundamentals of parameterized complexity*, volume 4. Springer, 2013.
- [26] P. G. Drange. *Parameterized Graph Modification Algorithms*. PhD thesis, The University of Bergen, 2015.
- [27] P. G. Drange, M. S. Dregi, D. Lokshantov, and B. D. Sullivan. On the threshold of intractability. In *Proceedings of the 23rd Annual European Symposium on Algorithms*, pages 411–423, Patras, Greece, September 2015.

- [28] P. G. Drange, M. S. Dregi, and R. B. Sandeep. Compressing bounded degree graphs. In *LATIN*, volume 9644 of *Lecture Notes in Computer Science*, pages 362–375. Springer, 2016.
- [29] T. Ebenlendr, P. Kolman, and J. Sgall. An approximation algorithm for bounded degree deletion. <http://kam.mff.cuni.cz/~kolman/papers/star.pdf>.
- [30] U. Feige. A threshold of $\ln n$ for approximating set cover. *Journal of the ACM*, 45(4):634–652, July 1998.
- [31] U. Feige, M. Hajiaghayi, and J. R. Lee. Improved approximation algorithms for minimum weight vertex separators. *SIAM Journal on Computing*, 38(2):629–657, 2008.
- [32] S. Fiorini, G. Joret, and U. Pietropaoli. Hitting diamonds and growing cacti. In *Proceedings of the International Conference on Integer Programming and Combinatorial Optimization*, pages 191–204, 2010.
- [33] F. V. Fomin, S. Kratsch, M. Pilipczuk, M. Pilipczuk, and Y. Villanger. Tight bounds for parameterized complexity of cluster editing with a small number of clusters. *Journal of Computer and System Sciences*, 80(7):1430–1447, 2014.
- [34] F. V. Fomin, D. Lokshtanov, N. Misra, and S. Saurabh. Planar F-deletion: Approximation, kernelization and optimal FPT algorithms. In *Proceedings of the IEEE 53rd Annual Symposium on Foundations of Computer Science*, pages 470–479, 2012.
- [35] T. Fujito. A unified approximation algorithm for node-deletion problems. *Discrete Applied Mathematics*, 86(2-3):213–231, 1998.
- [36] H. N. Gabow. An efficient reduction technique for degree-constrained subgraph and bidirected network flow problems. In *Proceedings of the 15th Annual ACM Symposium on Theory of Computing*, pages 448–456, 1983.
- [37] X. Gao, B. Xiao, D. Tao, and X. Li. A survey of graph edit distance. *Pattern Analysis and Applications*, 13(1):113–129, 2010.
- [38] M. Grohe, S. Kreutzer, R. Rabinovich, S. Siebertz, and K. Stavropoulos. Colouring and covering nowhere dense graphs. In E. W. Mayr, editor, *Graph-Theoretic Concepts in Computer Science*, pages 325–338. Springer Berlin Heidelberg, 2016.
- [39] S. Guha and S. Khuller. Approximation algorithms for connected dominating sets. In *European symposium on algorithms*, pages 179–193. Springer, 1996.
- [40] J. Guo, F. Hüffner, and R. Niedermeier. A structural view on parameterizing problems: Distance from triviality. In *International Workshop on Parameterized and Exact Computation*, pages 162–173. Springer, 2004.
- [41] A. Gupta, E. Lee, J. Li, P. Manurangsi, and M. Włodarczyk. Losing treewidth by separating subsets. *CoRR*, abs/1804.01366, 2018.
- [42] V. Guruswami and E. Lee. Inapproximability of H-transversal/packing. *SIAM Journal on Discrete Mathematics*, 31(3):1552–1571, 2017.
- [43] S. Har-Peled and K. Quanrud. Approximation algorithms for polynomial-expansion and low-density graphs. *SIAM Journal on Computing*, 46(6):1712–1744, 2017.

- [44] D. J. Harvey and D. R. Wood. Parameters tied to treewidth. *Journal of Graph Theory*, 84(4):364–385, 2017.
- [45] D. S. Hochbaum. Approximation algorithms for the set covering and vertex cover problems. *SIAM Journal on computing*, 11(3):555–556, 1982.
- [46] D. Huang and S. Pettie. Approximate generalized matching: f -factors and f -edge covers. *CoRR*, abs/1706.05761, 2017.
- [47] F. Hüffner, C. Komusiewicz, and A. Nichterlein. Editing graphs into few cliques: Complexity, approximation, and kernelization schemes. In *Proceedings of the 14th International Symposium on Algorithms and Data Structures*, pages 410–421. Springer, 2015.
- [48] B. M. P. Jansen, D. Lokshtanov, and S. Saurabh. A near-optimal planarization algorithm. In *Proceedings of the 25th Annual ACM-SIAM Symposium on Discrete Algorithms*, pages 1802–1811, 2014.
- [49] D. S. Johnson. Approximation algorithms for combinatorial problems. *Journal of Computer and System Sciences*, 9(3):256–278, 1974.
- [50] K. Kawarabayashi. Planarity allowing few error vertices in linear time. In *Proceedings of the 50th Annual IEEE Symposium on Foundations of Computer Science*, pages 639–648. IEEE, 2009.
- [51] K. Kawarabayashi and A. Sidiropoulos. Polylogarithmic approximation for minimum planarization (almost). In *Proceedings of the 58th IEEE Annual Symposium on Foundations of Computer Science*, pages 779–788, Berkeley, CA, October 2017.
- [52] S. Khot and O. Regev. Vertex cover might be hard to approximate to within $2 - \epsilon$. *Journal of Computer and System Sciences*, 74(3):335–349, 2008.
- [53] H. A. Kierstead and D. Yang. Orderings on graphs and game coloring number. *Order*, 20(3):255–264, 2003.
- [54] K.-I. Ko and H. Friedman. Computational complexity of real functions. *Theoretical Computer Science*, 20(3):323–352, 1982.
- [55] C. Komusiewicz. Tight running time lower bounds for vertex deletion problems. *TOCT*, 10(2):6:1–6:18, 2018.
- [56] M. Kotrbčák, R. Královič, and S. Ordyniak. Edge-editing to a dense and a sparse graph class. In *Proceedings of the 12th Latin American Symposium on Theoretical Informatics*, pages 562–575. Springer, 2016.
- [57] M. S. Krishnamoorthy and N. Deo. Node-deletion NP-complete problems. *SIAM Journal on Computing*, 8(4):619–625, 1979.
- [58] E. Lee. Partitioning a graph into small pieces with applications to path transversal. In *Proceedings of the 28th Annual ACM-SIAM Symposium on Discrete Algorithms*, pages 1546–1558. Society for Industrial and Applied Mathematics, 2017.
- [59] C. Lenzen and R. Wattenhofer. Minimum dominating set approximation in graphs of bounded arboricity. In *Proceedings of the International Symposium on Distributed Computing*, pages 510–524. Springer, 2010.

- [60] J. M. Lewis. On the complexity of the maximum subgraph problem. In *Proceedings of the 10th Annual ACM Symposium on Theory of Computing*, pages 265–274. ACM, 1978.
- [61] J. M. Lewis and M. Yannakakis. The node-deletion problem for hereditary properties is NP-complete. *Journal of Computer and System Sciences*, 20(2):219–230, 1980.
- [62] D. R. Lick and A. T. White. k -degenerate graphs. *Canadian Journal of Mathematics*, 22:1082–1096, 1970.
- [63] C. Lund and M. Yannakakis. The approximation of maximum subgraph problems. In *Proceedings of the International Colloquium on Automata, Languages, and Programming*, pages 40–51. Springer, 1993.
- [64] C. Lund and M. Yannakakis. On the hardness of approximating minimization problems. *Journal of the ACM*, 41(5):960–981, 1994.
- [65] A. Magen and M. Moharrami. Robust algorithms for on minor-free graphs based on the Sherali-Adams hierarchy. In *Approximation, Randomization, and Combinatorial Optimization. Algorithms and Techniques*, pages 258–271. Springer, 2009.
- [66] D. Marx. Parameterized coloring problems on chordal graphs. *Theoretical Computer Science*, 351(3):407–424, 2006.
- [67] D. Marx. Parameterized complexity and approximation algorithms. *The Computer Journal*, 51(1):60–78, 2008.
- [68] D. Marx and I. Schlotter. Obtaining a planar graph by vertex deletion. *Algorithmica*, 62(3-4):807–822, 2012.
- [69] L. Mathieson. The parameterized complexity of editing graphs for bounded degeneracy. *Theoretical Computer Science*, 411(34):3181–3187, 2010.
- [70] L. Mathieson and S. Szeider. Parameterized graph editing with chosen vertex degrees. In *Combinatorial Optimization and Applications*, pages 13–22. Springer, 2008.
- [71] D. W. Matula and L. L. Beck. Smallest-last ordering and clustering and graph coloring algorithms. *Journal of the ACM*, 30(3):417–427, 1983.
- [72] D. Moshkovitz. The projection games conjecture and the NP-hardness of $\ln n$ -approximating set-cover. In *Approximation, Randomization, and Combinatorial Optimization. Algorithms and Techniques*, pages 276–287. Springer, 2012.
- [73] D. Moshkovitz and R. Raz. Two-query pcp with subconstant error. *Journal of the ACM*, 57(5):29, 2010.
- [74] J. Nešetřil and P. O. de Mendez. Tree-depth, subgraph coloring and homomorphism bounds. *European Journal of Combinatorics*, 27(6):1022–1041, 2006.
- [75] J. Nešetřil and P. O. de Mendez. On nowhere dense graphs. *European Journal of Combinatorics*, 32(4):600–617, 2011.
- [76] J. Nešetřil and P. O. de Mendez. *Sparsity: Graphs, Structures, and Algorithms*. Algorithms and Combinatorics. Springer Berlin Heidelberg, 2012.

- [77] M. Okun and A. Barak. A new approach for approximating node deletion problems. *Information Processing Letters*, 88(5):231–236, 2003.
- [78] P. Orponen and H. Mannila. On approximation preserving reductions: complete problems and robust measures. Technical Report C-1987-28, Dept. of Computer Science, University of Helsinki, Finland, 1987.
- [79] C. H. Papadimitriou and M. Yannakakis. Optimization, approximation, and complexity classes. *Journal of Computer and System Sciences*, 43(3):425–440, 1991.
- [80] B. A. Reed. Finding approximate separators and computing tree width quickly. In *Proceedings of the 24th Annual ACM Symposium on Theory of Computing*, pages 221–228, 1992.
- [81] N. Robertson and P. D. Seymour. Graph minors. II. Algorithmic aspects of tree-width. *Journal of Algorithms*, 7(3):309–322, 1986.
- [82] N. Robertson and P. D. Seymour. Graph minors. XIII. The disjoint paths problem. *Journal of Combinatorial Theory, Series B*, 63(1):65–110, 1995.
- [83] M. Schaefer. The graph crossing number and its variants: A survey. *The Electronic Journal of Combinatorics*, 1000:21–22, 2013.
- [84] L. Trevisan. Non-approximability results for optimization problems on bounded degree instances. In *Proceedings of the 33rd Annual ACM Symposium on Theory of Computing*, pages 453–461, 2001.
- [85] M. Xiao. A parameterized algorithm for bounded-degree vertex deletion. In *Proceedings of the 22nd International Conference on Computing and Combinatorics*, pages 79–91, 2016.
- [86] M. Yannakakis. Node-and edge-deletion NP-complete problems. In *Proceedings of the 10th Annual ACM Symposium on Theory of Computing*, pages 253–264, 1978.
- [87] X. Zhu. Colouring graphs with bounded generalized colouring number. *Discrete Mathematics*, 309(18):5562–5568, 2009.