

Meta-Learning with Hessian-Free Approach in Deep Neural Nets Training

Boyu Chen

Fudan University
17110180037@fudan.edu.cn

Wenlian Lu

Fudan University
wenlian@fudan.edu.cn

Ernest Fokoue

Rochester Institute of Technology
epfeqa@rit.edu

Abstract

Meta-learning is a promising method to achieve efficient training method towards deep neural net and has been attracting increases interests in recent years. But most of the current methods are still not capable to train complex neuron net model with long-time training process. In this paper, a novel second-order meta-optimizer, named Meta-learning with Hessian-Free (MLHF) approach, is proposed based on the Hessian-Free approach. Two recurrent neural networks are established to generate the damping and the precondition matrix of this Hessian-Free framework. A series of techniques to meta-train the MLHF towards stable and reinforce the meta-training of this optimizer, including the gradient calculation of H . Numerical experiments on deep convolution neural nets, including CUDA-convnet and ResNet18(v2), with datasets of CIFAR10 and ILSVRC2012, indicate that the MLHF shows good and continuous training performance during the whole long-time training process, i.e., both the rapid-decreasing early stage and the steadily-decreasing later stage, and so is a promising meta-learning framework towards elevating the training efficiency in real-world deep neural nets.

1 Introduction

Meta-learning, often referred to as *learning-to-learn*, has attracted a steady increase of interest from deep learning researchers in recent years (Andrychowicz et al. 2016; Chen et al. 2016; Wichrowska et al. 2017; Li and Malik 2016; Li and Malik 2017; Ravi and Larochelle 2016; Wang et al. 2016; Finn, Abbeel, and Levine 2017). In contrast to hand-crafted optimizers like Stochastic Gradient Descent (SGD) and related methods like ADAM (Kingma and Ba 2014) and RMSprop (Tieleman and Hinton 2012), the methodology of meta-learning essentially revolves around the harnessing of a trained meta-optimizer, typically via recurrent neural networks (RNN), to infer the best descent directions, which are used to train the target neural networks, with the finality of achieving a better learning performance. In statistical machine learning, artificial intelligence and data science, meta-learning is increasingly deemed a promising learning methodology, by virtue of the widely held belief among researchers and practitioners, that "meta-trained" neural networks can "learn" much "more effective"

Copyright © 2019, Association for the Advancement of Artificial Intelligence (www.aaai.org). All rights reserved.

descent directions than their counterparts trained via hand-crafted methods.

A meta-learning method is essentially twofold: (i) a well-turned neural network that outputs the "learned" heuristic descent direction; and (ii) a decomposition mechanism to share and substantially reduce the number of meta-parameters and thereby enhance its generality, so that the trained meta-optimizer can work for at least one class of neural network learning tasks. The most notable decomposition mechanisms in the past few years include the so-called *coordinate-wise* framework (Andrychowicz et al. 2016) and the *hierarchical* framework (Wichrowska et al. 2017) developed in the context of Recurrent Neural Networks (RNN). However, it is crucial to note that most current meta-learning methods cannot both (a) remain stable with long-training process on complex target network, and (b) still be more effective than their hand-crafted counterparts (Wichrowska et al. 2017). Hence, *developing an efficient meta-optimizer along with a good framework that is stable with acceptable computing cost*, remains a major challenge that impedes the practical application of meta-learning methods to training deep neural networks.

In this paper, we propose a novel second-order meta-optimizer, which utilizes the Hessian-Free method (Martens 2010) as its core framework. Specifically, the contribution and novelty of this paper include:

- Successful and effective adaptation of the well-known Hessian-Free method to the meta-learning paradigm;
- Achievement of noteworthy learning improvements in the form of substantial reductions in the learning-to-learn losses of the recurrent neural networks of the meta-optimizer;
- Demonstrated evidence of sustained non-vanishing learning progress and improvements for long-time training processes, especially in the context of practical deep neural networks, including CUDA-Convnet (Krizhevsky 2012) and ResNet18(v2) (He et al. 2016).

Related Works

Meta-learning has a long history, indeed almost as long as the development of artificial neural network itself, with the earliest exploration attributed to Schmidhuber(1987). Many

contributions around the central theme of meta-learning appeared soon after the incipient paper, proposing a wide variety of learning algorithms (Sutton 1992; Naik and Mammon 1992; Hochreiter and Schmidhuber 1997). Around the same time, Bengio, Bengio, and Cloutier(1990), Bengio et al.(1992), Bengio, Bengio, and Cloutier(1995) introduced the idea of learning locally parameterized rules instead of back-propagation.

In recent years, the framework of coordinate-wise RNN proposed by (Andrychowicz et al. 2016) illuminated a promising orient towards a meta-learned optimizer can be employed to a wide variety of neural network architectures, which inspired the current surge in the development of meta-learning. Andrychowicz et al.(2016) also adapted the Broyden-Fletcher-Goldfarb-Shanno (BFGS) algorithm (Atkinson 2008) with the inverse of Hessian matrix regarded as the memory, and coordinate-wise RNN as the controller of a Neural Turing Machine (Graves, Wayne, and Danihelka 2014). Li and Malik(2016) proposed a similar approach but with training RNN of the meta-optimizer by reinforcement learning. Ravi and Larochelle(2016) further enriched the method suggested and developed by Andrychowicz et al.(2016), by adapting it to the few short learning tasks. Chen et al.(2016) used RNN to output the queue point of Bayesian optimization to train the neural network, instead of outputting descent directions. For other meta-learning fields, Finn, Abbeel, and Levine(2017) proposed the Model-Agnostic Meta-Learning method by introducing a new parameter initialization strategy to enhance its generalization performance.

However, the L2L optimizer in Andrychowicz et al.(2016)’s work, which use coordinate-wise RNN to output the descent direction directly is argued unable to perform stable and continuous loss descent during the whole training process, especially when generalized to complicated neural networks(Wichrowska et al. 2017). To conquer this, Wichrowska et al.(2017) proposed a hierarchical framework to implement this *learning-to-learn* idea to train large-scale deep neural networks such as Inception v3 and ResNet v2 on ILSVRC2012 with big datasets that yielded better performances in terms of generalization than its predecessors. However, in comparison to the hand-crafted optimizer, e.g. momentum, on large-scale deep neural networks and dataset, this learning-to-learn paradigm developed still has an ample room to be improved.

2 Preliminaries

Let f denote a neural network driving by a collection of parameters w such that upon receiving input x from some input space say \mathcal{X} , the network delivers $z = f(x, w)$, where $z \in \mathcal{Y}$, for some output space \mathcal{Y} . Let $y \in \mathcal{Y}$ be the true label corresponding to $x \in \mathcal{X}$. The learning process of a neural network consists of finding among all possible neural networks f , the one that minimizes the expected loss $\mathcal{L}(w) = \mathbb{E}[l(f(X; w), Y)]$, where the loss function $l(\cdot, \cdot)$ is a nonnegative bivariate function defined on $\mathcal{Y} \times \mathcal{Y}$, and used to measure the loss $l(z, y) = l(f(x, w), y)$ incurred from using $z = f(x, w)$ as a predictor of y .

Since we always care the loss on a mini-batch, we still use l, x, z, y to note the mini-batch version of loss, input and label from here and do not use the single sample version any more. Furthermore, for simplicity, we shall from here to use $l(\cdot; w)$ in place of the evaluation of $l(f(x, w), y)$, whenever and wherever such a use will be deemed unambiguous.

2.1 Natural Gradient

Gradient descent as an optimization tool permeates most machine learning processes. The essential goal of the gradient descent method is to *provide the direction in the tangent space of the parameter w that decreases the loss function the most*. The well-known *first-order gradient* is the fastest direction with respect to the Euclidean l_2 metric, and is the basis of most gradient descent algorithms in practice, like Stochastic Gradient Descent (SGD) and virtually all momentum-driven learning methods like those introduced by (Rumelhart, Hinton, and Williams 1986; Kingma and Ba 2014; Tieleman and Hinton 2012).

However, as argued by Amari(1998), the l_2 metric of the parameter’s tangent space in fact assumes that all the parameters have the same weight in metric but does not take the characteristics of the neural network into consideration. In addition, this metric does not possess the parameter invariant property (Martens 2010; Amari 1998). To circumvent this limitation, the concept of *natural gradient* for neural networks was developed (Park, Amari, and Fukumizu 2000; Martens 2010; Martens 2014; Desjardins et al. 2015; Martens and Grosse 2015). One of a general definition is

$$\nabla_w^n l = \lim_{\epsilon \rightarrow 0} \frac{1}{\epsilon} \arg \min_{d, m(w, w+d) < \frac{\epsilon^2}{2}} (l(w+d) - l(w))$$

where the metric is defined as $m(w, w+d) = l(f(x, w), f(x, w+d))$. Assuming (1). $l(z, z) = 0$, for all z ; (2). $l(z, z') \geq 0$, for all z and z' ; (3). l is differentiable with respect to z and z' which is true for the mean square loss and the cross-entropy loss, the metric $m(w, w')$ has the following expansion

$$m(w, w+d) = \frac{1}{2} d^\top H d + o(\|d\|_2^3), \quad H = \frac{\partial z}{\partial w}^\top H_l \frac{\partial z}{\partial w} \quad (1)$$

where $\frac{\partial z}{\partial w}$ is the Jacobian matrix of $f(x, w)$ with respect to w and $H_l = \frac{\partial^2}{\partial z^2} l(z, z')|_{z=z'=f(x, w)}$ is the Hessian matrix of $l(z, z')$ with respect to z when $z = z' = f(x, w)$. Hence, H is a Generalized Gauss-Newton matrix (GGN) (Schraudolph 2002) and the natural gradient is specified as

$$\nabla_w^n l = \arg \min_{\|d\|_H=1} \langle d, \frac{\partial l}{\partial w} \rangle = -\alpha' H^{-1} \frac{\partial l}{\partial w} \quad (2)$$

where $\|d\|_H = \sqrt{d^\top H d}$ and $\alpha' = 1/\|H^{-1} \frac{\partial l}{\partial w}\|_H$ is the normalization scalar. More specially, if $l(z, z')$ is the cross-entropy loss, then H is the Fisher information matrix, which agrees with the original definition in (Amari 1998).

It’s been found in many applications that natural gradient performs much better than gradient descent (Martens 2014). However, the calculation of the natural gradient during the learning process for deep neural networks, is fraught with

tough difficulties: specifically, basically calculating H^{-1} directly usually cost unacceptable time in implement, and for deep neural networks, calculating H on a small mini batch of the training data always causes H to lose rank, which leads to the instability of calculating H^{-1} . For second difficulty, one alternative is to use the damping technique (Martens and Sutskever 2011; LeCun et al. 1998), which consists of using \bar{H} in place of H , with $\bar{H} = H + \lambda I$, where λ is a positive scalar. However, it turns out that selecting the value of λ is sensitive: if λ is too large, then the natural gradient degenerates to the weighted gradient; on the other hand, if λ is too small, the natural gradient could be too aggressive due to the low rank of H_l on a mini batch of the training data. One of a well-known auto adaptive damping technique is Levenberg-Marquardt heuristic (Moré 1978), which still needs additional calculation of $l(\cdot; w + d)$ periodicity during training.

2.2 Natural Gradient by Hessian-Free Approach

Due to the above difficulty associate with the high computational cost of H^{-1} , it makes sense to avoid any method that needs to directly compute H^{-1} . One of the earliest Hessian-Free methods for neural networks was proposed by (Martens 2010; Martens and Sutskever 2011), and was used to calculate the natural gradient for deep neural networks. The key idea of the Hessian-Free method is twofold: (i) calculate Hv ; and (ii) calculate $H^{-1}v$.

First, to achieve $Hv = \frac{\partial z}{\partial w}^\top H_l \frac{\partial z}{\partial w} v$ (equation (1)), we can calculate in turn (1). $\mu = \frac{\partial z}{\partial w} v$, (2). $u = H_l \mu$, and then (3). $Hv = \frac{\partial z}{\partial w}^\top u$. (Pearlmutter 1994; Wengert 1964) suggested a special difference forward process to be used to calculate $\mu = \frac{\partial z}{\partial w} v$; $u = H_l \mu$ is easy when H_l is of low rank. And, it is notable that $(Hv)^\top = u^\top \frac{\partial z}{\partial w}$ is a standard backward process. Also, this difference forward and standard backward processes can be applied to calculate $\bar{H}v = Hv + \lambda v$ as well.

Second, with the efficient calculation of Hv , the natural gradient $H^{-1}v$ can be approximated by the Preconditioned Conjugate Gradient method (PCG) (Atkinson 2008), since it only requires the methodology for calculating $H(\cdot)$, and does not need any other information from H . This iterative process can be captured as follows:

$$x_n, r_n = \text{PCG}(v, H, x_0, P, n, \epsilon) \quad (3)$$

where x_0 is the initial vector, P is the *Preconditioned Matrix*, which takes a positive definite diagonal matrix in practices, n is the number of iterations, and ϵ is the error threshold for stopping; The output x_n is the numerical solution of equation $Hx = v$ and r_n is the residual vector: $r_n = v - Hx_n$. The more detailed PCG can be viewed in algorithm 1 of the supplementary material. It should be highlighted that the choice of x_0 and P has a substantial effect on the convergence of the PCG method.

In the Hessian-Free method to train a neural network, around 10 ~ 100 iterations are generally needed for PCG to guarantee convergence at each training iteration of the neural network (Martens and Sutskever 2012), which leads a much higher computational cost than the first-order gradient

methods, which prevents this method popular to be used to train a large-scale deep neural networks on big datasets.

2.3 Natural Gradient Method by Factorized Approximation

Besides Hessian-Free method, there are other developments of natural gradient by exploring efficient factorized approximations of H^{-1} to reduce the high computational cost of calculating $H^{-1}v$. For instance, TONGA (Roux, Manzagol, and Bengio 2008) and kfac (Martens and Grosse 2015; Grosse and Martens 2016) are the ripest natural gradient methods but their powers usually rely on the specific neural networks architectures to make sure the H^{-1} approximate to be factorizable. Hence, despite the remarkable performance achieved on these network architectures, they are not the general methodology for any possible networks.

3 Meta-Learning with Hessian-Free approach

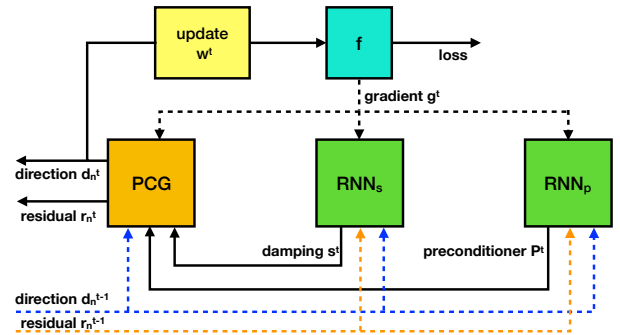

Figure 1: The architecture of Meta-Learning with Hessian-Free (MLHF) approach: superscript t stands for the step of training the target neural network, and g for the (standard) gradient of w , s and P for the damping parameters and Preconditioned matrix respectively. d_n and r_n are the descent direction and the residual generated by MLHF; The dash lines illustrate the directions of meta-trained where the gradient is forbidden to back-propagate (See section 3.1).

To conquer the disadvantage of the Hessian-Free approach but still enjoy the advantages of the natural gradient, we propose a novel approach that combines the Hessian-Free method with the meta-learning paradigm. We specifically use a variant of the damping technique with $\bar{H} = H + \text{diag}(s)$, where the vector $s = [s_1, \dots, s_n] \in \mathbb{R}^n$ of parameters has nonnegative components, i.e., $s_i \geq 0$ for all i . The vector s is referred to as the vector of *damping parameters*. This variant has a stronger representation capability than the original damping version for which $s = \lambda I$. Meanwhile, we generate the damping parameters s and the diagonal preconditioned matrix P by two coordinate-wise RNNs (Andrychowicz et al. 2016), RNN_s and RNN_p respectively.

The global computation architecture of this method is illustrated in figure 1 and the specific pseudo-codes can be viewed in Algorithm 1. With the meta-trained RNN_s and

RNN_p , at each training step of the neural network $f(x, w)$, RNN_s and RNN_p infer the damping parameter vector s and the diagonal preconditioned matrix P to the PCG algorithm (1). The PCG algorithm outputs the approximation of the natural gradient $H^{-1}v$ that gives the descent direction of $l(\cdot; w)$.

Algorithm 1: Meta-Learning with Hessian-Free Approach (MLHF)

Inputs : $n(\leq 4)$, learning rate lr , model f , loss function l

$d_n^{-1} \leftarrow 0$; $r_n^{-1} \leftarrow 0$; $t \leftarrow 0$
initialize parameters w^0

while not terminated **do**

 get mini-batch input x^t and label y^t
 calculate $z^t = f(x^t, w^t)$ and $l^t = l(z^t, y^t)$

 calculate gradient $g^t = \frac{\partial l^t}{\partial w^t}$

$d_0^t \leftarrow d_n^{t-1}$; $r_0^t \leftarrow r_n^{t-1}$

$s^t \leftarrow \text{RNN}_s(d_0^t, r_0^t, g^t)$;

$P^t \leftarrow \text{diag}(\text{RNN}_p(d_0^t, r_0^t, g^t))$

def $H^t v = \frac{\partial z^t}{\partial w^t}^\top H^t \frac{\partial z^t}{\partial w^t} v + s^t \odot v, \forall v$

$d_n^t, r_n^t \leftarrow \text{PCG}(g^t, H^t, d_0^t, P^t, n, \epsilon = 0)$

$w^{t+1} \leftarrow w^t - lr * d_n^t$

$t \leftarrow t + 1$

end

Outputs: w^t

The network structures of RNN_s and RNN_p are coordinate-wise as same as that presented in (Andrychowicz et al. 2016). In the experiment, we only use RNN_s and RNN_p to generate descent directions for the following six type of layer parameters in target network: (i) convolution kernels; (ii) convolution biases; (iii) full connection weights; (iv) full connection biases; (v) batch-norm parameter γ ; and (vi) batch-norm parameter β . The RNNs for each coordinates of the same type layer parameters in the target network share the same meta-parameters, while their state for different coordinates are separated and independent; But for parameter coordinates of different types, RNN meta-parameters are also independent. In addition, the learning rate lr for training the target neural network is fixed to $lr = b_{tr}/b_{mt}$, where b_{tr} is the batch size in target network training and b_{mt} is the batch size in meta-training, because the magnitude of the damping parameters s work as the learning rate implicitly. On the other hand, the initial vector of PCG at the training iteration t takes the output vector of PCG at the previous iteration $t - 1$, as suggested by (Martens and Sutskever 2012).

3.1 Training meta-parameters of the RNN_s and RNN_p

At each meta-training iteration, we use Back-Propagation-Through-Time (BPTT) (Werbos 1990) to meta-train RNN_s and RNN_p on a short sequence of sampled training process on target network, but with different loss functions as follows. Let $t = 1, \dots, T$ be the iterative count of a se-

quence of training process on the target network in one meta-training iteration, the loss function of RNN_p is defined as

$$l_p = \frac{1}{T} \sum_t \frac{-\langle d_n^t, g^t \rangle}{\sqrt{\langle d_n^t, H^t d_n^t \rangle}},$$

where d_n^t, H^t, g^t are defined in Algorithm 1.¹ It can be seen that minimizing l_p exactly matches the definition of the natural gradient given in (2). This is indeed a very encouraging feature as it points to the accuracy of the estimation of the natural gradient by a few iterations of the PCG method. The loss function for RNN_s is defined as

$$l_s^t = l(f(x^{t+1}, w^{t+1}), y^{t+1}) + l(f(x^t, w^{t+1}), y^t) - 2 \times l(f(x^t, w^t), y^t), \quad (4)$$

$$l_s = \frac{\sum_t l_s^t e^{l_s^t}}{\sum_t e^{l_s^t}}. \quad (5)$$

Here l_s^t is inspired by (Andrychowicz et al. 2016) with some modifications consisting of adding the second item $l(f(x^t, w^{t+1}), y^t)$ in (4). The motivation for using this term comes from one of the challenges of meta-training, namely that *RNN has the tendency to predict the next input and to fit for it, but the mini-batch x^t is indeed unpredictable in meta-training*, a challenge that tends to cause overfitting, or make training hard at the early stage. Adding this item in (4) can reduce such an influence, and thereby stabilize the meta-training process. Thus, l_s is the softmax weighted average over all l_s^t . For the sample of the training process on the target network, an experiment replay (Mnih et al. 2015; Schaul et al. 2015) is also used to store and replay the initial parameters w^0 .

Stop gradient propagation During the meta-training RNN_s and RNN_p for predigestion, we do not propagate the gradient of the meta-parameter through w^t, g^t, d_0^t, r_0^t in algorithm 1 and figure 1 in the BPTT rollback, $l(f(x^t, w^t), y^t)$ of the third term in (4), and all $e^{l_s^t}$ in (5).

Another advantage of stopping back-propagation of gradients of w^t, g^t, d_0^t, r_0^t is to simplify the gradient of multiplication Hv in PCG iterations. In detail, for $u = Hv$ (without the damping part), the H 's gradient in the back-propagation progress is not conducted. For the gradient of v , we can get $\frac{\partial l}{\partial v} = H \frac{\partial l}{\partial u}$, which means that the gradient operator of $H(\cdot)$ is itself. By this technique, the calculation of the second-order gradient in meta-training is not necessarily any more, which also reduces GPU memory usage and simplifies the calculation flow graph in practice.

3.2 Computation Complexity

Compared with the inference of the RNN, the major time consumption of the MLHF method is on the part dedicated to the calculation of the gradient and Hv at each iteration of

¹Another natural choice is to minimize the square of the norm of r_n in PCG, namely $l_p = \frac{1}{T} \sum_t \|r_n^t\|_2^2$, but it seems not as good as using (2), considering the fact that $\|r_n^t\|_2^2$ has quite a different scale, and that it is hard to achieve stability in the initial phase of meta-training.

PCG. As described in section 2.2, calculating Hv mainly involves a special difference forward and a standard backward process. By contrast, calculating the gradient requires a standard forward and backward process. Difference forward is a little faster than the standard forward process, because they can share intermediate results between different iterations of PCG. If one ignores the speed difference between two types of forward process, the time complexity is then found to be $O((n+1)K)$, where n is the maximum number of iterations in PCG, and K is the time that takes to finish once calculation of Hv . In the experiments of section 4, we set $n = 4$, which usually results in a training process up to about twice as long as SGD for each iteration.

4 Experiments

In this section, we implement the MLHF method of Algorithm 1 via TensorFlow (Abadi et al. 2016). Specifically, RNN_s and RNN_p are two-layered LSTM (Hochreiter and Schmidhuber 1997) with $\tanh(\cdot)$ as the preprocess and a linear map following softplus as the post-process. Each layer is composed of 4 units. In the meta-training process, the roll-back length of BPTT is set to 10. We use Adam as the optimizer for the meta-training of the RNNs, and the maximum number n of iterations of PCG is fixed to 4 by default if there is no other instruction.

In section 4.1 and 4.4, the MLHF performance is evaluated on a simple model (CUDA-convnet) and a more complicated model (ResNet18(v2)) respectively, in comparison with the first-order gradient optimizers, including RMSprop, adam, SGD + momentum (noted as SGD(m)). For CUDA-convnet, we also compare the MLHF with other natural gradient optimizers, including kfac, Hessian-Free with fixed damping (noted as HF(Fixed)), Hessian-Free with the Levenberg-Marquardt heuristic auto-adaptive damping technique (noted as HF(LM)) in section 4.2.

We do not compare the MLHF with other natural gradient optimizers on ResNet18(v2), because kfac and HF (Fixed, LM) were reported to prefer a larger batch size ($b = 512$) (Martens 2010; Grosse and Martens 2016) towards stable training, which is out of the limitation of the GPU memory. All the experiments were done on a single Nvidia GTX Titan Xp, and the code can be viewed in <https://www.github.com/ozzzp/MLHF>. See table 1 in supplementary material for hyper parameters' config of all optimizers.

4.1 Convnet on CIFAR10

CUDA-Convnet (Krizhevsky 2012) is a simple CNN with 2 convolutional layers and 2 fully connected layers. Here, we use the variant of CUDA-Convnet which drops off the LRN layer and uses the fully connected layer instead of the locally connected layer on the top of the model. This model is simple but has $186k$ parameters, which is still more than the models implemented in the previous learning-to-learn literature. We meta-train a given MLHF optimizer with batch size $b_{mt} = 64$ by BPTT on the first 3/5 training dataset of CIFAR10 (Krizhevsky and Hinton 2009) for 250 epochs. After meta-training, we validate this meta-trained optimizer

and compare with the first-order optimizers by training the same target model on the remaining 2/5 training dataset with batch size $b_{tr} = 128$. The test performance is inferred on the test dataset.

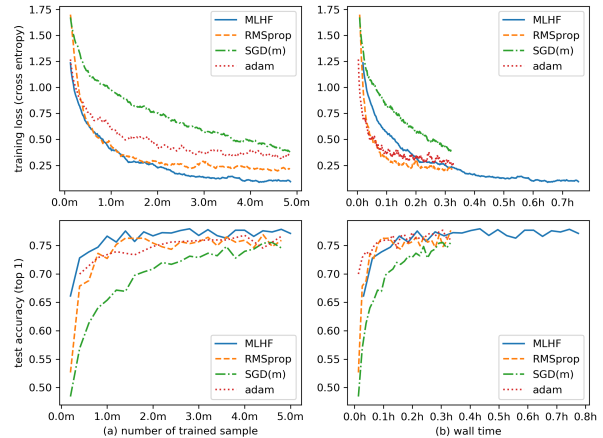

Figure 2: Performance of the training processes of the MLHF compared with the first-order optimizers on the CUDA-Convnet model of the remaining 2/5 training dataset of CIFAR10 for 250 epochs. Top row : loss (cross entropy) on the training dataset; Bottom row: accuracy on the test dataset; Left column: on the scale of the number of training samples; Right column: on the scale of wall time. Batch size b_{tr} of all optimizers was set to 128.

Figure 2 shows that the MLHF optimizer achieves lower loss in the training data and better inference accuracy in the test data than RMSprop, Adam, and SGD(m) based on same batch size in number of trained sample. However, it is not surprising that the MLHF cost around double amount of time as much as these first-order optimizer per iteration in average.

4.2 Comparison with Other Natural Gradient Optimizer on Convnet and CIFAR10

We use the same meta-training configuration as section 4.1 and compare its performance against other natural gradient based optimizer, including kfac, HF(Fixed) and HF(LM), except that the batch size b_{tr} is set to 512 for stabilizing these natural gradient optimizer. Specifically, for HF(Fixed) and HF(LM), PCG is run for sufficient iterations (see table 1 in supplementary materials) to convergence. In comparison, our MLHF still takes 4 iterations for PCG, which is far away from convergence (See section 4.3 for details).

As shown in figure 3, HF(LM), kfac and MLHF achieve almost the same final loss descent, but the HF(Fixed) has a litter higher final loss descent than the others, although the HF(Fixed) descends rapidly in early stage. In comparison, the HF(LM) descends much flatter during early stage than the others, and obtains the worst generalization performance among all. Compared with the HF(LM) and HF(Fixed), the MLHF performs well on both final loss descent and generalization accuracy during the entire training process. Due

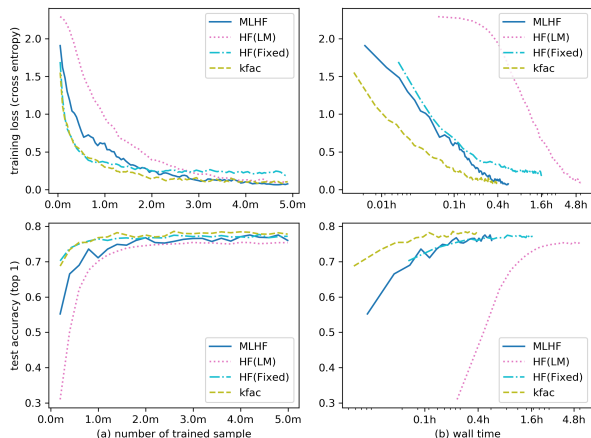

Figure 3: Performance of the training processes of MLHF compared with other natural gradient based optimizers on the CUDA-Convnet model of the remaining 2/5 training dataset of CIFAR10 for 250 epochs. Top row: loss (cross entropy) on the training dataset; Bottom row: accuracy on the test dataset; Left column: on the linear scale of the number of training sample; Right column: on the logarithmic scale of the wall time. Batch size b_{tr} of all optimizers was set to 512.

to the limited PCG iteration count of the MLHF, it is faster than the HF(LM) and HF(Fixed) on the scale of the wall time. This evidences that the damping by RNN_s works well in comparison to the other damping techniques, and the introduce of learning to learn technique is indeed speed up training and get a better performance as well.

The kfac achieves the best performance among all optimizers. One interpretation is that the kfac was doing a lot of online estimation of the approximation of Hessian inverse (Martens and Grosse 2015). However, this online estimation strongly depends on handcrafted factorized approximation of Hessian inverse, specified towards given network architecture (Martens and Grosse 2015). Hence, its Hessian inverse is essentially different from and more stable than those methods based on only a single batch, such as MLHF, HF(Fixed) and HF(LM), which are instead general frameworks and avoid manual designing this factorization approximation.

4.3 Ablation of RNN_p

This subsection aims to verify the efficiency of RNN_p towards calculating the natural gradient. We use the same meta-training configuration as section 4.1 but use the whole training dataset and conduct meta-training the MLHF by the following four configurations:

1. Remove RNN_p and set iteration count of PCG to 20.
2. Remove RNN_p and keep 4 iteration count of PCG.
3. Keep RNN_p , but set iteration count of PCG to 2.
4. Keep all default.

We highlight that config (1) has the best performance of PCG but a the largest computation cost.

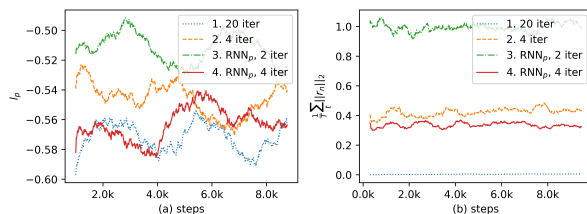

Figure 4: Ablation contrast of l_p (a) and $\frac{1}{T} \sum_t \|r_n\|_2$ (b) in meta-training with respect to iteration step for the underlying four configurations of the MLHF.

Figure 4 (a) and (b) illustrate the following observations. First, with the help of RNN_p , very few (4) iterations of PCG (config 4) can estimate the natural gradient as precisely/accurately as a far greater number of iterations of PCG (config 1) measured by l_p (Figure 4 (a)); however, 4 iterations is far away from convergence of PCG, in contrast, 20 iterations (config 1) can guarantee a good convergence of PCG, measured by the mean of $\|r_n\|_2^2$ (Figure 4 (b)). Second, in contrast, without RNN_p , few iterations of PCG (config 2) results in a bad estimation of natural gradient and of course far away from convergence of PCG. Finally, we highlight that 4 iterations could be the optimal number for PCG with the help of RNN_p , because further reduction of the number of iteration, i.e., 2 iterations of PCG (config 3), results in both a bad approximation of natural gradient and a bad convergence of PCG.

4.4 ResNet on ILSVRC2012

To validate the generalization of the MLHF between different datasets and different (but similar) neural network architectures, we implement a *mini version* of the ResNet (He et al. 2016) model on whole CIFAR10 training dataset for 250 epochs, which has 9 res-block with channel [16, 16, 16, 32, 32, 32, 64, 64, 64], for meta-training. Then we use the meta-trained MLHF to train the ResNet18(v2) on ILSVRC2012 (Deng et al. 2012) dataset. In the meta-training, the batch size $b_{mt} = 128$, while in target training on ILSVRC2012, the batch size $b_{tr} = 64$, due to the limitation of GPU memory.

Figure 5 shows that the MLHF achieves the best performance in both training loss and testing accuracy among all evaluated optimizers on the scale of the training sample number. It has also been seen that the MLHF has effective descent progress of the loss function during the whole long-time training, which overcomes the major shortcoming of the previous meta-learning methods (Wichrowska et al. 2017). However, figure 5 (b) indicates that MLHF costs around double time as much as the first-order optimizer cost per iteration in average.

5 Conclusions and Discussions

In this paper, we proposed and implemented a novel second-order meta-optimizer based on the Hessian-Free approach.

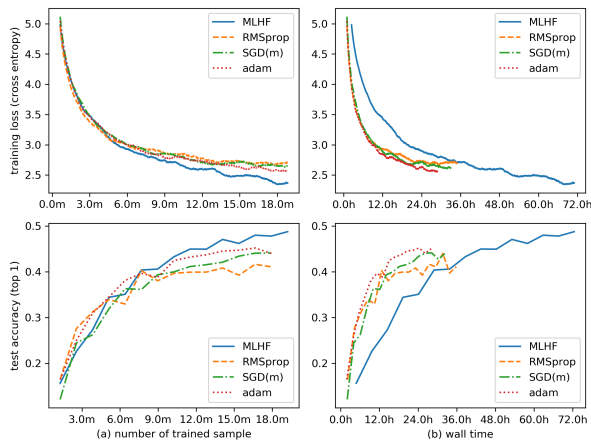

Figure 5: Performance of the training processes of MLHF with other optimizers on ResNet18 (v2) on the dataset ILSVRC2012. Top row: loss (cross entropy) on the training dataset; Bottom row: accuracy on the test dataset; Left column: on the scale of the number of training sample; Right column: on the scale of wall time. Batch size b_{tr} of all optimizers was set to 64.

We used the PCG algorithm to approximate the natural gradient as the optimal descent direction for neural network training. Thanks to the coordinate-wise framework, we designed two recurrent networks: RNN_s and RNN_p , to infer the damping parameters and the preconditioned matrix, with a very small number of iterations, the PCG algorithm can achieve a good approximation of the natural gradient with an acceptable computational cost. Furthermore, we used a few specifically designed techniques to efficiently meta-train the proposed MLHF. We have illustrated that our proposed meta-optimizer efficiently makes progress during both the early and later stages of the whole long-time training process in a large-scale neural network with big datasets, and specifically demonstrated this strength of our method on the CUDA-convnet on CIFAR10 and ResNet18 (v2) on ILSVRC2012. The presented meta-optimizer can be a promising meta-learning framework to generalize its performance from simple model and small dataset to large but similar model and big dataset, and elevate the training efficiency in practical deep neural networks.

We present some interpretation of the advantages of the MLHF approach as follows.

Advantage of RNN Damping One good choice of damping on each batch is to make H approximate to the Hessian Matrix on the whole training dataset. It is speculated that using RNN damping implicitly induces the capability of the method to learn to memorize the history and decode out the diagonal part of the Hessian during meta-training. However, numerical validation to this point is difficult because as far as we know, even on a batch, there is still no effective way to calculate the diagonal part of the Generalized Gauss-Newton matrix.

Stability of MLHF Compared with L2L, the explanation of the stability of the MLHF is twofold: First, it can be seen that regardless of how RNN_s is trained, if RNN_p works well in the sense that d_n approaches near $(H + \text{diag}(s))^{-1}g$ well, $\langle d_n, g \rangle \simeq g^T (H + \text{diag}(s))^{-1}g$ is always equal or greater than 0. This result implies that even if RNN_s is over-fitting, the loss $l(;w)$ can still decrease, because d_n partially follows the standard gradient. Therefore, the training process inherently has a built-in mechanism to efficiently descend gradually even at the early stage. Second, since each coordinate of d_n is determined by all coordinates of s and P , it may result in a good error-tolerance.

Despite the promising performances described above, we are keenly aware of the main limitation of our proposed method, namely the still relatively high computational cost (even surely much better than the previous Hessian-Free approach), compared with the first-order gradient method. It appears that the price we paid for algorithmic stability is indeed an increase in computational cost.

For the future work, we will evaluate the generalization performance of the MLHF on a more extensive variety of neural networks, including RNN, and RCNN (Girshick 2015). We also plan to develop the distributed version of the MLHF in order to implement on a larger popular network like ResNet50. Another one of our future orients is to accelerate this MLHF method. We are fully confident, based on our very promising results and performances, that we can make the learning-to-learn approach exhibit its inherent promised efficacy in the training and effective use of deep neural networks.

References

- [Abadi et al. 2016] Abadi, M. i. n.; Barham, P.; Chen, J.; Chen, Z.; Davis, A.; Dean, J.; Devin, M.; Ghemawat, S.; Irving, G.; Isard, M.; et al. 2016. Tensorflow: A system for large-scale machine learning. In *OSDI*, volume 16, 265–283.
- [Amari 1998] Amari, S.-I. 1998. Natural gradient works efficiently in learning. *Neural computation* 10(2):251–276.
- [Andrychowicz et al. 2016] Andrychowicz, M.; Denil, M.; Gomez, S.; Hoffman, M. W.; Pfau, D.; Schaul, T.; and de Freitas, N. 2016. Learning to learn by gradient descent by gradient descent. In *Advances in Neural Information Processing Systems*, 3981–3989.
- [Atkinson 2008] Atkinson, K. E. 2008. *An introduction to numerical analysis*. John Wiley & Sons.
- [Bengio, Bengio, and Cloutier 1990] Bengio, Y.; Bengio, S.; and Cloutier, J. 1990. *Learning a synaptic learning rule*. Universit é de Montr é al, D é partement d’informatique et de recherche op é rationnelle.
- [Bengio, Bengio, and Cloutier 1995] Bengio, S.; Bengio, Y.; and Cloutier, J. 1995. On the search for new learning rules for anns. *Neural Processing Letters* 2(4):26–30.
- [Bengio et al. 1992] Bengio, S.; Bengio, Y.; Cloutier, J.; and Gecsei, J. 1992. On the optimization of a synaptic learning rule. In *Preprints Conf. Optimality in Artificial and Biological Neural Networks*, 6–8. Univ. of Texas.

- [Chen et al. 2016] Chen, Y.; Hoffman, M. W.; Colmenarejo, S. G. o. m.; Denil, M.; Lillicrap, T. P.; Botvinick, M.; and de Freitas, N. 2016. Learning to learn without gradient descent by gradient descent. *arXiv preprint arXiv:1611.03824*.
- [Deng et al. 2012] Deng, J.; Berg, A.; Satheesh, S.; Su, H.; Khosla, A.; and Fei-Fei, L. 2012. IISVRC-2012, 2012. URL <http://www.image-net.org/challenges/LSVRC>.
- [Desjardins et al. 2015] Desjardins, G.; Simonyan, K.; Pascanu, R.; et al. 2015. Natural neural networks. In *Advances in Neural Information Processing Systems*, 2071–2079.
- [Finn, Abbeel, and Levine 2017] Finn, C.; Abbeel, P.; and Levine, S. 2017. Model-agnostic meta-learning for fast adaptation of deep networks. *arXiv preprint arXiv:1703.03400*.
- [Girshick 2015] Girshick, R. 2015. Fast r-cnn. *arXiv preprint arXiv:1504.08083*.
- [Graves, Wayne, and Danihelka 2014] Graves, A.; Wayne, G.; and Danihelka, I. 2014. Neural Turing machines. *arXiv preprint arXiv:1410.5401*.
- [Grosse and Martens 2016] Grosse, R., and Martens, J. 2016. A kronecker-factored approximate fisher matrix for convolution layers. In *International Conference on Machine Learning*, 573–582.
- [He et al. 2016] He, K.; Zhang, X.; Ren, S.; and Sun, J. 2016. Deep residual learning for image recognition. In *Proceedings of the IEEE conference on computer vision and pattern recognition*, 770–778.
- [Hochreiter and Schmidhuber 1997] Hochreiter, S., and Schmidhuber, J. u. r. 1997. Long short-term memory. *Neural computation* 9(8):1735–1780.
- [Kingma and Ba 2014] Kingma, D. P., and Ba, J. 2014. Adam: A method for stochastic optimization. *arXiv preprint arXiv:1412.6980*.
- [Krizhevsky and Hinton 2009] Krizhevsky, A., and Hinton, G. 2009. Learning multiple layers of features from tiny images.
- [Krizhevsky 2012] Krizhevsky, A. 2012. cuda-convnet: High-performance c++/cuda implementation of convolutional neural networks. *Source code available at <https://github.com/akrizhevsky/cuda-convnet2> [March, 2017]*.
- [LeCun et al. 1998] LeCun, Y.; Bottou, L. e. o.; Orr, G. B.; and Müller, K.-R. 1998. Efficient backprop. In *Neural networks: Tricks of the trade*. Springer. 9–50.
- [Li and Malik 2016] Li, K., and Malik, J. 2016. Learning to optimize. *arXiv preprint arXiv:1606.01885*.
- [Li and Malik 2017] Li, K., and Malik, J. 2017. Learning to optimize neural nets. *arXiv preprint arXiv:1703.00441*.
- [Martens and Grosse 2015] Martens, J., and Grosse, R. 2015. Optimizing neural networks with kronecker-factored approximate curvature. In *International conference on machine learning*, 2408–2417.
- [Martens and Sutskever 2011] Martens, J., and Sutskever, I. 2011. Learning recurrent neural networks with hessian-free optimization. In *Proceedings of the 28th International Conference on Machine Learning (ICML-11)*, 1033–1040. Cite-seer.
- [Martens and Sutskever 2012] Martens, J., and Sutskever, I. 2012. Training deep and recurrent networks with hessian-free optimization. In *Neural networks: Tricks of the trade*. Springer. 479–535.
- [Martens 2010] Martens, J. 2010. Deep learning via hessian-free optimization. In *ICML*, volume 27, 735–742.
- [Martens 2014] Martens, J. 2014. New insights and perspectives on the natural gradient method. *arXiv preprint arXiv:1412.1193*.
- [Mnih et al. 2015] Mnih, V.; Kavukcuoglu, K.; Silver, D.; Rusu, A. A.; Veness, J.; Bellemare, M. G.; Graves, A.; Riedmiller, M.; Fidjeland, A. K.; Ostrovski, G.; et al. 2015. Human-level control through deep reinforcement learning. *Nature* 518(7540):529.
- [Moré 1978] Moré, J. J. 1978. The levenberg-marquardt algorithm: implementation and theory. In *Numerical analysis*. Springer. 105–116.
- [Naik and Mammone 1992] Naik, D. K., and Mammone, R. 1992. Meta-neural networks that learn by learning. In *Neural Networks, 1992. IJCNN., International Joint Conference on*, volume 1, 437–442. IEEE.
- [Park, Amari, and Fukumizu 2000] Park, H.; Amari, S.-I.; and Fukumizu, K. 2000. Adaptive natural gradient learning algorithms for various stochastic models. *Neural Networks* 13(7):755–764.
- [Pearlmutter 1994] Pearlmutter, B. A. 1994. Fast exact multiplication by the hessian. *Neural computation* 6(1):147–160.
- [Ravi and Larochelle 2016] Ravi, S., and Larochelle, H. 2016. Optimization as a model for few-shot learning.
- [Roux, Manzagol, and Bengio 2008] Roux, N. L.; Manzagol, P.-A.; and Bengio, Y. 2008. Topmoumoute online natural gradient algorithm. In *Advances in neural information processing systems*, 849–856.
- [Rumelhart, Hinton, and Williams 1986] Rumelhart, D. E.; Hinton, G. E.; and Williams, R. J. 1986. Learning representations by back-propagating errors. *nature* 323(6088):533.
- [Schaul et al. 2015] Schaul, T.; Quan, J.; Antonoglou, I.; and Silver, D. 2015. Prioritized experience replay. *arXiv preprint arXiv:1511.05952*.
- [Schmidhuber 1987] Schmidhuber, J. u. r. 1987. *Evolutionary principles in self-referential learning, or on learning how to learn: the meta-meta-... hook*. Ph.D. Dissertation, Technische Universität München.
- [Schraudolph 2002] Schraudolph, N. N. 2002. Fast curvature matrix-vector products for second-order gradient descent. *Neural computation* 14(7):1723–1738.
- [Sutton 1992] Sutton, R. S. 1992. Adapting bias by gradient descent: An incremental version of delta-bar-delta. In *AAAI*, 171–176.
- [Tieleman and Hinton 2012] Tieleman, T., and Hinton, G.

2012. Lecture 6.5-rmsprop, coursera: Neural networks for machine learning. *University of Toronto, Technical Report*.

[Wang et al. 2016] Wang, J. X.; Kurth-Nelson, Z.; Tirumala, D.; Soyer, H.; Leibo, J. Z.; Munos, R.; Blundell, C.; Kumaran, D.; and Botvinick, M. 2016. Learning to reinforcement learn. *arXiv preprint arXiv:1611.05763*.

[Wengert 1964] Wengert, R. E. 1964. A simple automatic derivative evaluation program. *Communications of the ACM* 7(8):463–464.

[Werbos 1990] Werbos, P. J. 1990. Backpropagation through time: what it does and how to do it. *Proceedings of the IEEE* 78(10):1550–1560.

[Wichrowska et al. 2017] Wichrowska, O.; Maheswaranathan, N.; Hoffman, M. W.; Colmenarejo, S. G.; Denil, M.; de Freitas, N.; and Sohl-Dickstein, J. 2017. Learned optimizers that scale and generalize. *arXiv preprint arXiv:1703.04813*.

Supplemental Material

1 Preconditioned Conjugate Gradient

The Preconditioned Conjugate Gradient method (PCG) (Atkinson 2008), which captured in the main text as:

$$x_n, r_n = \text{PCG}(v, H, x_0, P, n, \epsilon) \quad (1)$$

can be described more detail as in algorithm 1. It is easily to confirm that PCG only requires the methodology for calculating $H(\cdot)$, and does not need any other information from H .

Algorithm 1: Preconditioned conjugate gradient algorithm (PCG)

Aim : compute $A^{-1}b$
Inputs : b, A , initial value x_0 ,
Preconditioned Matrix P ,
maximum iteration number n ,
error threshold ϵ

$r_0 \leftarrow b - Ax_0$
 $y_0 \leftarrow \text{solution of } Py = r_0$
 $p_0 \leftarrow y_0; i \leftarrow 0$
while $\|r_i\|_2 \geq \epsilon$ **and** $i \leq n$ **do**
 $\alpha_i \leftarrow \frac{r_i^\top y_i}{p_i^\top A p_i}$
 $x_{i+1} \leftarrow x_i + \alpha_i p_i; r_{i+1} \leftarrow r_i - \alpha_i A p_i$
 $y_{i+1} \leftarrow \text{solution of } Py = r_{i+1}$
 $\beta_{i+1} \leftarrow \frac{r_{i+1}^\top y_{i+1}}{r_i^\top y_i}$
 $p_{i+1} \leftarrow y_{i+1} + \beta_{i+1} p_i$
 $i \leftarrow i + 1$
end
Outputs: x_n with $x_n \simeq A^{-1}b$, residual error r_i

the back-propagation via PCG is not complicated as much as common imagination, since the self-gradient property of operator $H(\cdot)$, see section 3.1 for detail in main text.

2 Hyper-Parameter Selections in Experiments

Table 1 detailed note the config of all hyper-Parameters in experiments.

Optimizer	Parameter	Search Range
SGD(m)	lr	$\{0.1, 0.01, 0.001\} \times b_{tr}/b_{bl}$
	momentum	$\{0.9, 0.99, 0.999\}$
RMSprop	lr	$\{0.1, 0.01, 0.001\} \times b_{tr}/b_{bl}$
	decay	$\{0.9, 0.99, 0.999\}$
Adam	lr	$\{0.1, 0.01, 0.001\} \times b_{tr}/b_{bl}$
	β_1	$\{0.9, 0.99, 0.999\}$
	β_2	$\{0.9, 0.99, 0.999\}$
kfac (<i>tf official implement</i>)	lr	$\{1, 0.1, 0.01, 0.001\}$
	damping	$\{1, 0.1, 0.01, 0.001\}$
	cov_ema_decay	$\{0.9, 0.99, 0.999\}$
HF(Fixed) (<i>our implement</i>)	lr	$\{1, 0.1, 0.01, 0.001\}$
	n in PCG	20
	ϵ in PCG	1e-5
	P in PCG	I
	damping	$\{1, 0.1, 0.01, 0.001\}$
	momentum	0
HF(LM) (<i>our implement</i>)	lr	$\{1, 0.1, 0.01, 0.001\}$
	n in PCG	20
	ϵ in PCG	1e-5
	P in PCG	I
	init damping	$\{1, 0.1, 0.01, 0.001\}$
	decay in LM	$\{2/3, 0.9, 0.99, 0.999\}$
MLHF	lr	b_{tr}/b_{mt}
	n in PCG	4
	other	default

Table 1: hyper parameters' config of various optimizers in section 4 in the main text. The parameters were chosen from the search range via grid search. Of each experiment, b_{tr} is the batch size of target network training, while b_{mt} is which of meta-training. b_{bl} is the baseline batch size, and sets to 128 for section 4.1 and 256 for section 4.4 in main text.