

Live Recovery of Bit Corruptions in Datacenter Storage Systems

Amy Tai^{1,2}, Andrew Kryczka², Shobhit Kanaujia², Chris Petersen², Mikhail Antonov²,
Muhammad Waliji², Kyle Jamieson¹, Michael J. Freedman¹, and Asaf Cidon³

¹Princeton University

²Facebook, Inc.

³Stanford University and Barracuda Networks

Abstract

Due to its high performance and decreasing cost per bit, flash is becoming the main storage medium in datacenters for hot data. However, flash endurance is a perpetual problem, and due to technology trends, subsequent generations of flash devices exhibit progressively shorter lifetimes before they experience uncorrectable bit errors.

In this paper we propose extending flash lifetime by allowing devices to expose higher bit error rates. To do so, we present DIRECT, a novel set of policies that leverages latent redundancy in distributed storage systems to recover from bit corruption errors with minimal performance and recovery overhead. In doing so, DIRECT can significantly extend the lifetime of flash devices by effectively utilizing these devices even after they begin exposing bit errors.

We implemented DIRECT on two real-world storage systems: ZippyDB, a distributed key-value store backed by RocksDB, and HDFS, a distributed file system. When tested on production traces at Facebook, DIRECT reduces application-visible error rates in ZippyDB by more than 10^2 and recovery time by more than 10^4 . DIRECT also allows HDFS to tolerate a 10^4 – 10^5 higher bit error rate without experiencing application-visible errors.

1 Introduction

Flash is rapidly becoming the dominant storage medium for hot data in datacenters [50, 57], since it offers significantly lower latency and higher throughput than hard disks. Many storage systems are built atop flash, including databases [6, 9, 13, 33], caches [5, 43, 44, 61], and file systems [37, 53].

However, a perennial problem of flash is its limited endurance, or how long it can reliably correct raw bit errors. As device writes are the main contributor to flash wear, this lifetime is measured in the number of writes or program-erase (P/E) cycles the device can tolerate before exceeding an uncorrectable bit error threshold. Uncorrectable bit errors are device errors that are exposed to

the application and occur when there are too many raw bit errors for the device to correct.

In hyper-scale datacenter environments, operators constantly seek to reduce flash wear by limiting flash writes [19, 50]. At Facebook for example, a dedicated team monitors application flash writes to ensure they do not prematurely exceed manufacturer-defined device lifetimes. To make matters worse, each subsequent flash generation tolerates a smaller number of writes before reaching end-of-life (see Figure 1a) [31]. Further, given the scaling challenges of DRAM [38, 42], and the increasing cost gap between DRAM and flash [1, 28], many operators are migrating services from DRAM to flash [7, 27].

There is a variety of work that attempts to extend flash lifetime by delaying the onset of bit errors [6, 10, 25, 36, 45, 47, 48, 60, 63, 64]. This paper takes the opposite approach. We observe that flash endurance can be extended by *allowing* devices to go beyond their advertised uncorrectable bit error rate (UBER) and embracing the use of flash disks at much higher error rates. To do so however, distributed storage systems must be retrofitted with a new paradigm that does *not* assume corruption-free devices. Google recently released a whitepaper suggesting a similar approach [23].

Traditionally, distributed storage systems are built to tolerate machine or disk failures, not bit corruption on an individual data block. To recover from machine failures, storage systems re-replicate an entire server, but such heavy-handed recovery is inappropriate for handling errors that may affect only a single bit. Instead, our key insight is that minimizing *error amplification*, or the number of bits needed to recover a bit error, enables us to use corruption-prone devices by reducing the probability of application-visible errors and improving recovery performance.

We introduce Distributed error Isolation and REcovery Techniques (DIRECT), which is rooted in the observation that (1) datacenter storage systems replicate data

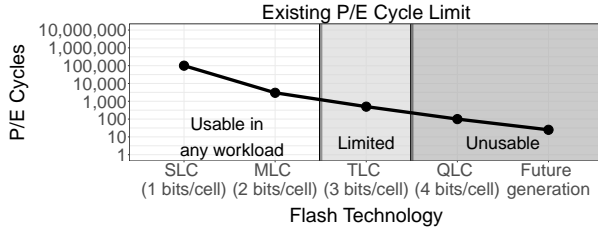

(a) Existing hardware-based error correction.

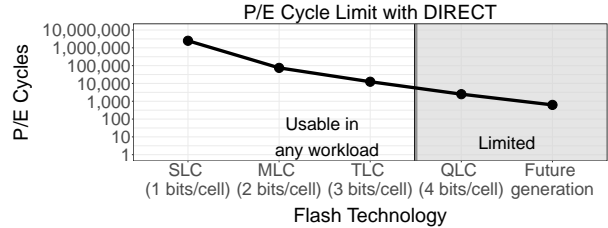

(b) Augmenting existing error correction with DIRECT.

Figure 1: For each generation of flash bit density, the average number of P/E cycles after which the uncorrectable bit error rate falls below the manufacturer specified level (10^{-15}). Beyond MLC, flash becomes constrained to read-heavy applications [24]. With current hardware-based error correction, with QLC technology and beyond, flash becomes almost unusable [20, 49, 52]. DIRECT enables the adoption of denser flash technologies because errors can be handled by the distributed storage application. The uncorrectable bit error rate that can be tolerated by DIRECT was computed using the model from §3.1, while the uncorrectable bit error rate to P/E conversion was computed using data from a Google study [57].

on remote servers, and (2) this redundancy can correct bit error rates orders of magnitude beyond the hardware error correction mechanisms implemented on the device. DIRECT is a set of three simple general-purpose policies that, when implemented, enable distributed storage systems to achieve high availability and correctness in the face of uncorrectable bit errors:

1. **Minimize error amplification.** DIRECT detects errors using existing error detection mechanisms (e.g., checksums) and recovers data from remote servers at the smallest possible granularity.
2. **Local metadata protection.** To recover from a corruption in local metadata (e.g., database index), often a large amount of data must be re-replicated. DIRECT avoids this by adding local redundancy to local metadata.
3. **Safe recovery semantics.** Any recovery operations on corrupted data must be serialized against concurrent read and write operations with respect to the system’s consistency guarantees.

We design and implement the DIRECT policies in two popular systems that are illustrative of widely-used storage architectures: (1) ZippyDB, a distributed key-value store used in production at Facebook and backed by RocksDB, a popular storage engine based on the log-structured merge tree [54], and (2) the Hadoop Distributed File System (HDFS), which is representative of distributed storage systems that perform full-block replication. In both systems, we minimize error amplification by isolating bit errors to data regions with sizes on the order of kilobytes, making recovery very fast compared to re-replication of an entire server.

DIRECT enables HDFS to tolerate much higher bit error rates because blocks in HDFS are immutable after write, so DIRECT fixes bit errors by comparing across replicas of the same block (§4.2). On the other hand, recovery is challenging in RocksDB due to background compaction operations and key-versioning. Compaction makes it difficult not only to find the corrupted region on

one replica in another replica (different servers store the same key-value pairs in different files), but also to ensure that the recovered key-value pairs have consistent versions. DIRECT must make use of the distributed layer in ZippyDB to solve both these problems (§4.1.4).

Applying DIRECT results in significant end-to-end improvements: it reduces application-visible error rates in ZippyDB by more than $100\times$, reduces recovery time by $10,000\times$, and reduces CPU consumption by 20%-49%. It enables HDFS to tolerate bit error rates that are $10,000\times$ - $100,000\times$ greater.

With these performance improvements, DIRECT can lead to significant increases in device lifetime, because it maintains the same probability of application-visible errors at much higher device UBERs (for the computation, see §3.1). An estimate of lifetime increase is shown in Figure 1b; we estimate the number of P/E cycles gained by running to higher UBERs from a Google study [57]. Depending on the system parameters, DIRECT can increase the lifetime of devices by 10- $100\times$. This allows datacenter operators to replace flash devices less often and adopt lower cost-per-bit flash technologies that have lower endurance. DIRECT also provides the opportunity to rethink the design of existing flash-based storage systems, which are brittle in the face of corruption errors. Furthermore, while this paper focuses on flash, DIRECT’s principles also apply in other storage mediums, including NVM and hard disks.

In summary, this paper makes several contributions:

1. We observe that flash lifetime can be extended by allowing devices to expose higher bit error rates.
2. We propose DIRECT, general-purpose software policies that enable storage systems to maintain performance and high availability in the face of high hardware bit error rates.
3. We design and implement DIRECT in two representative storage systems, ZippyDB and HDFS.
4. We demonstrate that DIRECT significantly speeds up recovery time due to disk corruptions, and signif-

icantly lowers application-observable errors in the resulting systems, allowing them to tolerate much higher hardware bit error rates.

2 Motivation

What Limits Flash Endurance? Flash chips are composed of memory cells, each of which stores an analog voltage value. The flash controller reads the value stored in a certain memory cell by sensing the voltage level of the cell and applying quantization to determine the discrete value in bits. The more bits stored in a cell, the narrower the voltage range that maps to each discrete bit, so more precise voltage sensing is required to get a correct read. Unfortunately, one of the primary ways to reduce cost per bit is to increase the number of bits per cell, which means that even small voltage perturbations can result in a misread.

Multiple factors cause voltage drift in a flash cell. The dominant source, especially in datacenter settings where most data is “hot,” is the program-erase (P/E) cycle, which involves applying a large high voltage to the cell in order to drain its stored charge, thus wearing the insulating layer in the flash cell [25]. This increases the voltage drift in subsequent values in the cell, which gradually leads to bit errors.

3D NAND is a recent technology that has been adopted for further increasing flash density by stacking cells vertically. While 3D NAND relaxes physical limitations of 2D NAND (traditional flash) by enabling vertical stacking, 3D NAND inherits the reliability problems of 2D NAND, and further exacerbates them, since a cell in 3D NAND has more adjacent (vertical) neighbors. For example, voltage retention is worse, because voltage can now leak in three dimensions [40, 51]. Similarly, disturb errors that occur when adjacent cells are read or programmed are also exacerbated [39, 59].

Existing Hardware Reliability Mechanisms. To correct bit errors, flash devices use error correcting codes (ECC), which are implemented in hardware. After the ECC pass, there could still be incorrect bits on the page. To address these errors, SSDs also employ internal RAID across the dies inside the flash device [14, 17]. After applying coding and RAID within the device, there will remain a certain rate of *uncorrectable bit errors* (UBER). Together, ECC and internal RAID mechanisms can drive the error rates of SSDs from the raw bit error rate of around 10^{-6} down to the 10^{-17} to 10^{-20} UBER range typical of enterprise SSDs [12]. “Commodity” SSD devices typically guarantee an UBER of 10^{-15} .

However, the level of RAID striping is constant across generations, because the number of dies inside a flash device remains constant. This means that the corrective power of RAID is fixed. While it is possible to create stronger ECC engines, the higher the corrective power of

the ECC, the more costly the device due to the complexity of the ECC circuit [4, 8].

Implications of Limited Flash Endurance. Flash technology has already reached the point where its endurance is inhibiting its adoption and operation in various data-center use cases. For example, QLC was recently introduced as the next generation flash cell technology. However, it can only tolerate 100-200 P/E cycles [20, 49, 52], so it can only be used for read-heavy use cases. Datacenter applications that deal with hot data, such as databases and analytics, typically need to update objects frequently. This has limited the adoption of QLC (and is the reason that Facebook has avoided QLC flash). Subsequent cell technology generations will suffer from even greater problems. Second, operational issues often dictate a device’s usage lifetime. While flash manufacturers are conservative with their flash device lifetimes [57], flash is still only used for its advertised lifetime to simplify operational complexity. Further, in a hyper-scale datacenter where it is common to source devices from multiple vendors, the most conservative estimate of device lifetime across vendors is typically chosen as the lifetime for a fleet of flash devices, so that the entire fleet can be installed and removed together. However, if the distributed storage layer could tolerate much higher device error rates, then datacenter operators would no longer have to make conservative and wasteful estimates about entire fleets of flash devices.

Third, because of the increase in DRAM prices due to its scaling challenges and tight supply [1, 28, 38, 42], datacenter operators are migrating services from DRAM to flash [7, 27]. This means that flash will be responsible for many more workloads, further exacerbating the flash endurance problem. Limited flash lifetime is already a problem in the datacenter, where operators must limit applications to a certain write throughput per day to prevent prematurely wearing out a device.

3 DIRECT Design

DIRECT is a set of policies that enables a distributed storage system to maintain high availability and correctness in the face of a high UBER. We define a distributed storage system as a set of many local stores coupled with a distributed protocol layer that replicates data and coordinates between the local stores. Figure 2a shows the DIRECT storage stack, which accommodates unreliable flash (flash that exposes high UBERs). There is existing work on how to make local file systems tolerate corruption errors (we survey some of these systems in §6). However, there is no existing work on how to enable distributed storage systems, or even local key-value stores, to tolerate bit corruption in a live production environment. DIRECT addresses these challenges.

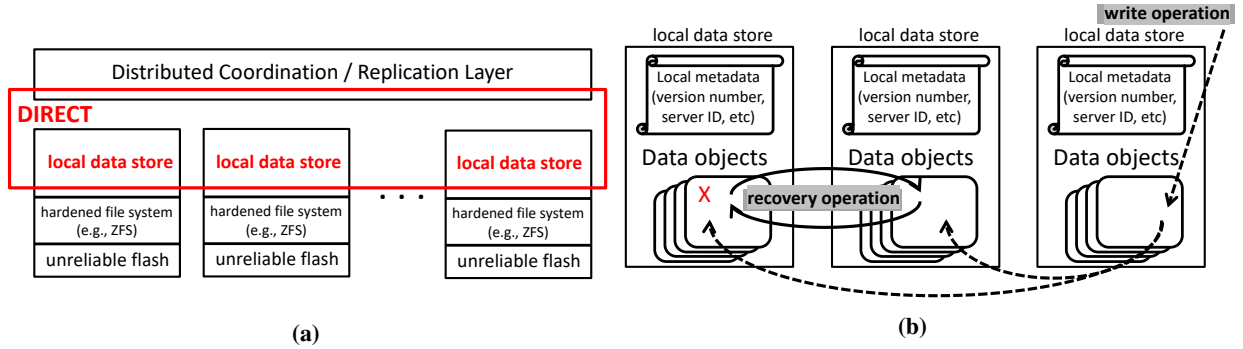

Figure 2: (a) DIRECT instruments cooperation between the local data stores and the distributed coordination layer to fix errors in the local data store. (b) Within the local data store, bit errors can affect either data objects or metadata. There must be precise semantics that define how recovery operations fixing data objects interact with write operations.

3.1 High Availability

Within the local data store, bit errors affect either application data or application metadata, as shown in Figure 2b. Maintaining multiple copies of each piece of data is the easiest way for a system to recover from bit errors. Our observation is that this redundancy already exists for application data!

Distributed Redundancy. Distributed storage systems typically use replication [22] or erasure coding [34, 56] to store redundant copies of data. Hot data, which is stored on flash storage, is typically replicated to avoid the higher bandwidth and CPU consumption associated with reconstructing erasure coded blocks [34]. In addition, erasure coding is not used for storage applications requiring fine-grained data access such as RocksDB. Since distributed storage systems assume storage devices correct device-level errors, they do not currently use replicas to correct bit errors [29], even though this redundancy can significantly boost bit error resilience.

Consider the following example. Suppose a data block is replicated in each of the three data stores shown in Figure 2b. If the block has size B , and the uncorrectable bit error rate (UBER) is E , then the expected number of errors in the block will be $B \cdot E$. Since the block is replicated across R different servers, the storage application can recover the block from a remote server when an error occurs in at most $R - 1$ of its replicas. In this case, the only way that the storage system would encounter an application-observable read error is when at least one error exists in *each* of the copies of the block. Therefore, the probability of an application-level read error can be expressed as:

$$\mathbb{P}[\text{error}] = (1 - (1 - E)^B)^R \approx (E \cdot B)^R$$

where we assume $E \cdot B \ll 1$ and use a Taylor series approximation.

Then for an UBER of $E = 10^{-15}$, a block size of $B = 128 \text{ MB}$ (typical of distributed file systems), and a replication factor of $R = 3$, the probability of error is

UBER	Probability of Application-Observable Error	
	Block Recovery	Chunk Recovery
10^{-10}	$1 \cdot 10^{-3}$	$3 \cdot 10^{-10}$
10^{-15}	$1 \cdot 10^{-18}$	$1 \cdot 10^{-28}$

Table 1: Probability of application-observable error comparing block-by-block recovery to chunk-by-chunk recovery, with an UBER of 10^{-10} , and 10^{-15} . Finer granularity recovery provides significantly higher protection against corruptions.

10^{-18} (files are measured in bytes, while UBER is in bits). This effectively is three orders of magnitude lower than the UBER of each local disk.

However, with relatively large blocks, the probability of encountering at least one error in all block replicas quickly increases as UBER increases. For example, for an UBER of $E = 10^{-10}$, the expected number of errors in a single block will be $B \cdot E = 0.1$. Thus, the probability of error in this case will be $\mathbb{P}[\text{error}] \approx 0.001$. We make the observation that reducing $E \cdot B$, by reducing B , will dramatically reduce the probability of error.

Minimizing Error Amplification. DIRECT captures this intuition with error amplification (B in the previous example), or the number of bytes required to recover a bit error. DIRECT observes that *the lower the error amplification, the lower the probability of error and the faster recovery can occur*. This similarly implies a shorter period of time spent in degraded durability and thus higher availability.

In the example above, suppose the system can recover data at a finer granularity, for example, at chunk size $C = 64 \text{ KB}$. Then a read error would occur if all three replicas of the same *chunk* have at least one bit error. The revised probability of read error is:

$$\mathbb{P}[\text{error}] = 1 - (1 - (1 - (1 - E)^C)^R)^{\frac{B}{C}}$$

Assuming $E \cdot C \ll 1$, Taylor series approximation leads to $(1 - (1 - E)^C)^R \approx (E \cdot C)^R$, and assuming this value

is much smaller than $\frac{B}{C}$, the probability of an application-observable error when correcting chunk-by-chunk is:

$$\mathbb{P}[\text{error}] \approx (E \cdot C)^R \cdot \frac{B}{C}$$

When $C = 64$ KB and $E = 10^{-10}$, this probability is $3 \cdot 10^{-10}$, which is much lower than the probability when recovering at the block level (see Table 1).

In HDFS, chunk recovery is precisely what allows DIRECT to tolerate higher bit error rates. The RocksDB data format is more complicated than the block format discussed in this section, but DIRECT also isolates errors to data blocks (~ 8 KB) in RocksDB, and this is responsible for significant improvements in recovery time.

Metadata Error Amplification. So far, we have discussed the effect of errors on data blocks. However, error amplification can be even more severe if the error occurs in local metadata. For example, a corrupted local key-value store index can prevent a data store from starting up, which can mean re-replication of hundreds of GBs of data. Even though the likelihood of errors in metadata is statistically lower than in data blocks (metadata typically takes up much less space than data), it requires stronger local protection to minimize error amplification. To address this problem, DIRECT either locally duplicates metadata or applies local software error correction.

3.2 Correctness

Minimizing error amplification of data blocks and correcting data from remote replicas enables performant, live recovery of corrupted data blocks. However, DIRECT must also ensure recovery operations preserve the correctness of the distributed storage system, which might be dealing with concurrent write and read operations. For example, in Figure 2b, after both recovery operation and write operation, the corrupted data block is both fixed and has the “correct” data with respect to consistency guarantees of the system.

Correct recovery is particularly difficult in RocksDB because of key versioning. The versions of the corrupted key-value pairs *are not known*, because the corruption prevents the data from being read. Hence in order to correctly recover corrupted key-value pairs, the system must locate some consistent (up-to-date) version of each pair. To do this, DIRECT forces recovery operations to go through the Paxos log in ZippyDB, which can provide correct ordering (§4.1.3).

3.3 DIRECT Policies

To summarize, DIRECT includes the following policies.

1. Systems must reduce error amplification of data objects and fix corruptions from remote replicas.
2. Systems must perform local metadata duplication to avoid high recovery costs from metadata corruption.

3. Systems must ensure safe recovery semantics.

Note that the first and second policies apply exclusively to the local data store and affect *performance*, while the third policy requires that the local data store interact with the distributed coordination layer to ensure *correctness* during recovery.

4 Implementing DIRECT

To demonstrate the use of the DIRECT approach, we integrate it into two systems: ZippyDB, a distributed key-value store backed by RocksDB, and HDFS, a popular distributed file system.

4.1 ZippyDB-DIRECT

4.1.1 ZippyDB Overview

ZippyDB is a distributed key-value store used within Facebook that is backed by RocksDB (i.e., RocksDB is the local data store in Figure 2a). ZippyDB runs on tens of thousands of flash servers at Facebook, which makes it an ideal target for DIRECT. ZippyDB provides a replication layer on top of RocksDB. ZippyDB is logically separated into shards, and each shard is fully replicated at least three ways. Each shard has a primary replica as well as a number of secondary replicas, wherein each replica is backed by a separate RocksDB instance residing on separate servers. Each ZippyDB server contains 100s of shards, including both primary and secondary replicas. Hence, each ZippyDB server actually contains a large number of separate RocksDB instances.

ZippyDB runs a Paxos-based protocol for shard operations to ensure consistency. The primary shard acts as the leader for the Paxos entry, and each shard also has a Paxos log to persist each Paxos entry. Writes are considered durable when they are committed by a quorum of shards, and write operations are applied to the local RocksDB store in the order that they are committed. A separate service is responsible for monitoring the primary and triggering Paxos role changes.

ZippyDB supports a variety of read consistencies depending on the client service: (1) strongly consistent reads, which go through the primary; (2) read-after-write consistency, which can be served by any replica if the client passes a Paxos entry to read-after; and (3) eventually consistent reads, which can go to any replica.

4.1.2 RocksDB Overview

RocksDB is a local key-value store that is based on a log-structured merge (LSM) tree [54]. RocksDB batches writes in-memory—each write receives a sequence number that enables key versioning—and flushes them into immutable files of sorted key-value pairs called sorted string table (SST) files. RocksDB SST files are composed of individually checksummed blocks, each of which can be a data block or a metadata block. The meta-

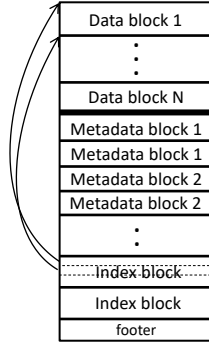

Figure 3: RocksDB SST file format. Index block entries point to keys in between data blocks, which means consecutive index block entries will form a key range that contains all keys in the sandwiched data block. DIRECT writes each metadata block at least twice in-line (or uses an error correction code).

data blocks include index blocks that point to the keys at the start of each data block (Figure 3) [11].

SST files are organized into levels. A key feature of RocksDB and other LSM tree-backed stores is background compaction, which periodically scans SST files and compacts them into lower levels, as well as performs garbage collection on deleted and overwritten keys.

4.1.3 Implementing DIRECT

In ZippyDB, if a compaction encounters a corruption, an entire server, which typically has 100s of gigabytes to terabytes of data, will shutdown and attempt to drain its RocksDB shards to another machine. Meanwhile, this sudden crash causes spikes in error rates and increases the load on other replicas while the server is recovering. To make matters worse, the new server could reside in a separate region, further delaying time to recovery. All this leads to high error amplification: a single bit error can cause the migration of terabytes of data.

Reducing Error Amplification of Data Blocks. We observe that checksums in RocksDB are applied at the data block level, so a data block is the smallest granularity at which a bit error can be recovered. Data blocks are lists of key-value pairs, and key-value pairs are replicated at the ZippyDB layer. So if the metadata on an SST file is correct (see below on how we protect per-SST file metadata), a corrupted data block can be recovered by fetching the pairs in the data block from another replica. However, this is challenging for two reasons.

First, compactions are non-deterministic in RocksDB and depend on a variety of factors such as available disk space and how compaction threads are scheduled. Hence, *two replicas of the same RocksDB instance will have a different set of SST files*, making it impossible to find an exact replica of the corrupted SST file, much less the corrupted data block. Second, because the block is

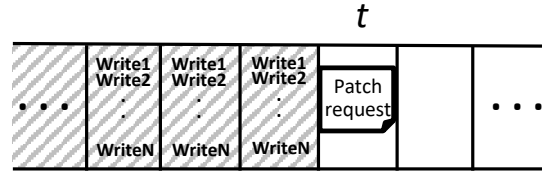

Figure 4: To serialize a patch properly, we add it as a request in the Paxos log. If the patch request is serialized at point t , then it must reflect all entries $t' < t$ (shaded). Furthermore, the patch request is not batched with any writes to ensure atomicity.

corrupted, it is impossible to know the exact key-value pairs that were stored in that block. Therefore, not only do we not know what data to look for on the other replica, we also don't know where to find it.

Instead of repairing the exact keys that are lost, we repair the corrupted data block by re-writing a larger key range that covers the keys in the corrupted block. The key range is determined from index blocks, which are a type of metadata block that exist at the end of every SST file and record a key in the range between consecutive data blocks, as shown in Figure 3. Hence, consecutive index block entries form a key range which is guaranteed to contain the lost keys.

Unfortunately, just knowing the key range is not enough: the existence of key versions in RocksDB and quorum replication in ZippyDB compounds the problem. In particular, a key must be recovered to a version greater than or equal to the lost key version, which could mean deleting it as key versions in RocksDB can be deletion markers. Additionally, if we naively fetch key versions from another replica, we may violate consistency.

Safe Recovery Semantics. To guide our recovery design, we introduce the following correctness requirement. Suppose we learn from the index blocks that we must re-replicate key range $[a, b]$. This key range is requested from another replica, which assembles a set of fresh key-value pairs in $[a, b]$, which we call a patch.

Safety Requirement: *Immediately after patch insertion, the database must be in a state that reflects some prefix of the Paxos log. Furthermore, this prefix must include the Paxos entries that originally updated the corrupted data block.*

In other words, patch insertion must bring ZippyDB to some consistent state *after* the versions of the corrupted keys; otherwise, if the patch inserts prior versions of the keys, then the database will appear to go backwards.

Because the Paxos log serializes updates to ZippyDB, the cleanest way to find a prefix to recover up to is to serialize the patch insertion via the Paxos log. Then if patch insertion gets serialized as entry t in the log, the log prefix of the patch must reflect all Paxos entries $t' < t$, as shown in Figure 4. Serializing a patch at index t tells us

exactly how to populate the patch. In particular, each key in the patch must be recovered to the largest $s < t$ such that s is the index of a Paxos entry that updates that key.

Furthermore, patch insertion must be atomic. Otherwise, it could be interleaved with updates to keys in the patch, which would violate the safety requirement, because then the version of the key in the patch would not reflect a prefix of t . This is actually a subtle point because ZippyDB batches many writes into a single Paxos entry, as shown in Figure 4. If patch insertion is batched with other writes, then the patch will not reflect the writes that are in front of it in the batch. Hence, we force the patch insertion to be its own Paxos entry.

Even though it stores a relatively small amount of data, the Paxos protocol itself can tolerate bit errors by writing an additional entry per Paxos entry (for more information, see PAR [18]).

Local Metadata Duplication. There are two flavors of metadata in RocksDB: metadata files and metadata blocks in SST files. Metadata files, such as a MANIFEST, OPTIONS, and CURRENT, are only read during startup and then cached in memory. We can easily protect these metadata files by locally replicating them, which adds a minimal space overhead (on the order of kilobytes per server). Other files such as LOG files don't need to be protected, as they simply contain printed log statements used for debugging.

Metadata blocks, however, must be protected because the integrity of the recovery process depends on uncorrupted index blocks, and index blocks are not replicated (since each local SST file is unique). We protect metadata blocks by writing them several times in-line in the same SST file. In our implementation, we write each metadata block twice¹. Protecting metadata enables us to isolate errors to a single data block, rather than invalidating an entire SST file.

4.1.4 DIRECT Recovery in ZippyDB

ZippyDB does not synchronously recover corrupted blocks encountered in user reads. Instead, it returns the error to the client, which will retry on a different replica, and ZippyDB will then trigger a manual compaction involving the file containing the corrupted data block.

ZippyDB triggers synchronous recovery only when a corruption error occurs during compaction. Figure 5 depicts this process. Importantly, we do not release a compaction's output files until the recovery procedure finishes; otherwise, stale key versions may reappear in the key ranges still undergoing recovery. Fortunately, because compaction is a background process, we can wait for recovery without affecting client operations.

¹For increased protection, metadata blocks can be locally replicated more than twice or protected with software error correction.

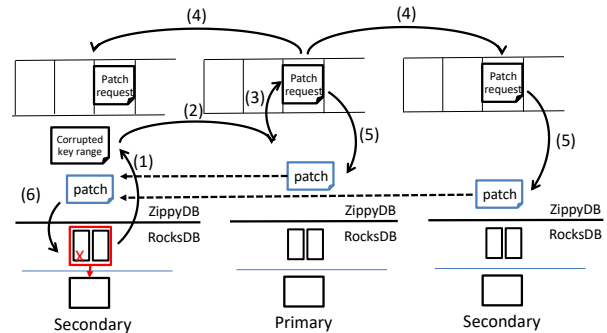

Figure 5: Recovering a corrupted RocksDB data block involves the following steps: (1) RocksDB compaction iterator determines the corrupted key range based on the index blocks of the SST files and reports this to ZippyDB. (2) The ZippyDB shard reports this error to the primary for that replica. (3) The primary shard adds the patch request to the Paxos log. (4) The Paxos engine replicates the request to all replicas. (5) Each replica tries to process the patch request. If the processing shard is *not* the corrupted shard, then it prepares a patch from its local RocksDB state and sends it to the corrupted shard. If the processing shard *is* the corrupted shard, then it waits for a patch from any of the other replicas. (6) The corrupted shard applies the fresh patch to its local RocksDB store.

Step (1) is implemented entirely within RocksDB. In particular, a RocksDB compaction iterator will record a corrupted key range when it's encountered, and then skip it to continue scanning. At the end of the iterator's lifetime, ZippyDB is notified about the corrupted key range. If there are multiple corrupt key ranges, they are batched into a single patch request.

Step (3) must go through the primary because the primary is the only shard that can propose entries to the Paxos log. Note that this does not mean primaries cannot recover from corrupted data blocks. The patch request that goes in the Paxos log is simply a no-op that reserves a point of reference for the recovery procedure and includes information necessary for recovery, such as the corrupted key ranges and the ID of the corrupted shard. Any replica that encounters the patch request in the log is by definition up-to-date to that point in the Paxos log, which means any replica that isn't the corrupted replica can send a patch to the corrupted replica.

In Step (5), an uncorrupted replica creates a patch on the affected key range with a RocksDB iterator. Note that it might encounter a bit corruption while assembling the patch. In practice the probability of this is very small because the number of keys covered by the patch is on the order of kilobytes (§5.1). However, if a corruption is encountered while assembling a patch, the replica simply does not send a patch. Therefore, for the patch request to fail, *both* (or more, if the replication factor is more than 3) uncorrupted replicas will have to encounter a bit

corruption, and this probability is low (see Table 1).

Step (6) is also implemented at the RocksDB level. When a replica applies a patch, simply inserting all the key-value pairs present in the patch is insufficient because of deleted keys. In particular, any key present in the requested key range and *not* present in the patch is an implicit delete. Therefore, to apply a patch, the corrupted shard must also delete any keys that it can see that aren't present in the patch. This case is possible because RocksDB deletes keys by inserting a tombstone value, which is inlined in SST files. Hence the corrupted data block may contain tombstone operators that delete a key, and these must be preserved.

4.1.5 Invalidating Snapshots

In RocksDB, users can request snapshots, which are represented by a sequence number. Then, for as long as the snapshot with sequence number s is active, RocksDB will not delete any version, s' , of a key where s' is the greatest version of the key such that $s' < s$. ZippyDB uses RocksDB snapshots to execute transactions. If RocksDB invalidates a snapshot, then the transaction using that snapshot will abort and retry.

A subtle side-effect of a corrupted data block is snapshot corruption. For example, suppose the RocksDB store has a snapshot at sequence number 100 and the corrupted data block contains a key with sequence number 90. For safety, we need to invalidate any snapshots that could have been affected by the corrupted key range. Because the data block is corrupted, it cannot be read, so we do not know whether this corruption affects snapshot 100. For now, we take the obviously correct approach and invalidate all local snapshots of the RocksDB shard affected by the corruption. In practice, this is reasonable because most RocksDB snapshots have short lifetimes.

4.2 HDFS-DIRECT

4.2.1 HDFS Overview.

HDFS is a distributed file system that is designed for storing large files that are sequentially written and read. Files are divided into 128MB blocks, and HDFS replicates and reads at the block level.

HDFS servers have three main roles: NameNode, JournalNode, and DataNode. The NameNode and JournalNodes store cluster metadata such as the cluster directory structure and mappings from block to DataNode. JournalNodes quorum-replicate updates to this metadata by running a protocol similar to Multi-Paxos; there is no leader election because the NameNode is the leader, and HDFS deployments run a ZooKeeper service to ensure there is always one live NameNode [3].

As with the Paxos log of ZippyDB, we can protect against bit errors in the JournalNode by adding an additional entry [18]. To prevent the JournalNode logs

from growing indefinitely, the NameNode takes periodic snapshots of the stored metadata. We divide the snapshots into 512 byte chunks and compute a CRC32 checksum for each chunk, just as with data blocks. During NameNode recovery, which runs only during recovery or startup mode and not during the steady-state, snapshot corruptions can be fixed by fetching the corresponding chunk from the standby NameNode, which acts as a hot NameNode backup.

DataNodes store actual HDFS data blocks (they are the local data stores in Figure 2), and they respond to client requests to read blocks. If a client encounters errors while reading a block, it will continue trying other DataNodes from the offset of the error until it can read the entire block. Once it encounters an error on a DataNode, the client will not try that node again. If there are no more DataNodes and the block is not fully read, the read fails and that block is considered missing.

Additionally, HDFS has a configurable background “block scanner” that periodically scans data blocks and reports corrupted blocks for re-replication. But the default scan interval is three weeks, and even if the periodic scan does catch bit errors before the next read of a block, the NameNode can only recover at the 128 MB block granularity. If there is a bit error in every replica of a block, then HDFS cannot recover the block.

4.2.2 Implementing DIRECT

Reducing Error Amplification of Data Blocks We leverage the observation that HDFS checksums every 512 bytes in each 128 MB data block. Corruptions thus can be narrowed down to a 512 byte chunk; verifying checksums adds no overhead, because by default HDFS will verify checksums during every block read. For streaming performance, the smallest-size buffer that is streamed during a data block read is 64 KB, so we actually repair 64 KB everytime there is a corruption. To mask corruption errors from clients, we repair a data block synchronously during a read. Under DIRECT, the full read (and recovery) protocol is the following.

Each 128 MB block in HDFS is replicated on three DataNodes, call them A, B, C . An HDFS read of a 128 MB block is routed to one of these DataNodes, say A . A will stream the block to the client in 64 KB chunks, verifying checksums before it sends a chunk. If there is a checksum error in a 64 KB chunk, then A will attempt to repair the chunk by requesting the 64 KB chunk from B . If the chunk sent by B also contains a corruption, then the checksum will be incorrect, and A will request the chunk from C (see Figure 6a).

If C also sends a corrupted chunk, then A will attempt to construct a correct version of the chunk through bit-by-bit majority voting: the value of a bit in the chunk is the majority vote across the three versions provided

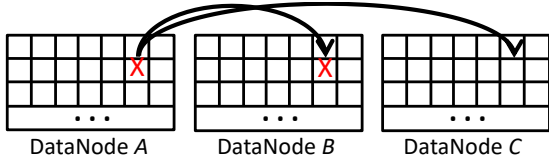

(a) A will attempt to correct a corrupted chunk by requesting it from other datanodes until it receives a clean chunk.

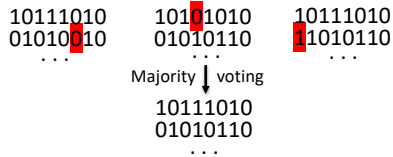

(b) If the chunk is corrupted on all datanodes, then A will attempt majority voting to reconstruct a clean chunk.

Figure 6: DataNodes will stream the read of a block in 64 KB chunks. When it encounters a checksum failure, a DataNode will try to repair the individual chunk.

by A, B, and C. The idea behind majority voting is that the probability that the corruptions on A, B, and C affect the same byte is very low, which means a majority vote across the three versions of the byte should end up with the correct data. After reconstructing the chunk via majority voting (Figure 6b), A will verify the checksums again; if the checksums fail, then the read fails. As we show in Section 5.2, UBERs have to be at least 10^{-8} in order for majority voting failures to affect read failures, which allows HDFS-DIRECT to tolerate on the order of a million times more bit errors than HDFS.

Note that bit-by-bit majority voting is possible only if the device can return pages with uncorrectable errors (see §6); otherwise, our HDFS implementation simply uses chunk-by-chunk recovery. Furthermore, for majority voting to add significant recovery power over chunk-by-chunk recovery, the number of corrupt bits returned by the device should be relatively small compared to the page size; the number of corrupt bits on a device page after running hardware ECC is dependent on the ECC function and its implementation.

Safe Recovery Semantics. Safety is straightforward in HDFS because data blocks are immutable once written, so there are never in-place updates that will conflict with chunk recovery. Before a client does a block read, it first contacts the NameNode to get the DataNode IDs of all the DataNodes on which the block is replicated. When a client sends a block read request to a DataNode, it also sends this set of IDs. Because blocks are immutable, these IDs are guaranteed to be correct replicas of the block, *if they exist*. It could be that a concurrent operation has deleted the block. In this case, if chunk recovery cannot find the block on another DataNode because it has been deleted, then it cannot perform recovery, so it

will return the original checksum error to the client. This is correct, because there is no guarantee in HDFS that concurrent read operations should see the instantaneous deletion of a block.

Local Metadata Duplication. Each role in HDFS has local metadata files that must be correct, otherwise the role cannot be started. These files include a VERSION file, as well as special files on the NameNode and JournalNode. For example, the NameNode stores a special file (`seen-txid`) which contains a high-water mark transaction ID. Any correct recovery of the existing cluster must be able to recover up to at least this transaction.

Metadata files are not currently protected in HDFS; thus, a single corruption will prevent the role from starting. To implement DIRECT, we add a standard CRC32 checksum at the beginning of each file and replicate the file twice so that there are actually three copies of the file on disk. If there is a checksum error when the file is read, the recovery protocol will visit each of the copies until it finds one with a correct checksum.

5 Evaluation

This section addresses the three following questions. (1) What is the highest UBER that ZippyDB and HDFS can tolerate with DIRECT? (2) How is ZippyDB’s recovery time affected by DIRECT? (3) What are the overheads of DIRECT on steady-state requests in HDFS?

Experimental Setup. To evaluate ZippyDB, we set up a cluster of Facebook servers that capture and duplicate live traffic from a heavily loaded service used in computing user feeds. To evaluate HDFS, we run experiments on a cluster of 10 machines (each with a role described below) each with 8 ARMv8 cores at 2.4 GHz, 96 GB of RAM, and 120 GB of flash. In the cluster, we allocate one machine each for a NameNode, standby NameNode, and JournalNode, and three machines run the DataNode role. Four machines act as HDFS clients. HDFS experiments have a load and read phase: in the load phase, we load the cluster with 200, 128MB files with random data. In the read phase, clients randomly select files to read. After the load phase, we clear the page cache.

Error Injection. To simulate UBERs, we inject bit errors into the files of both systems. In ZippyDB, we inject errors with a custom RocksDB environment that flips bits as they are read from a file. In HDFS, we run a script in between the load and read phases that flips bits in on-disk files and flushes them. For an UBER of μ , e.g. $\mu = 10^{-11}$, we inject errors at the rate of 1 bit flip per $1/\mu$ bits read. We tested with UBERs higher than the manufacturer advertised 10^{-15} to test the system’s performance under high error rates, and so that we can measure enough bit errors during an experiment time of 12

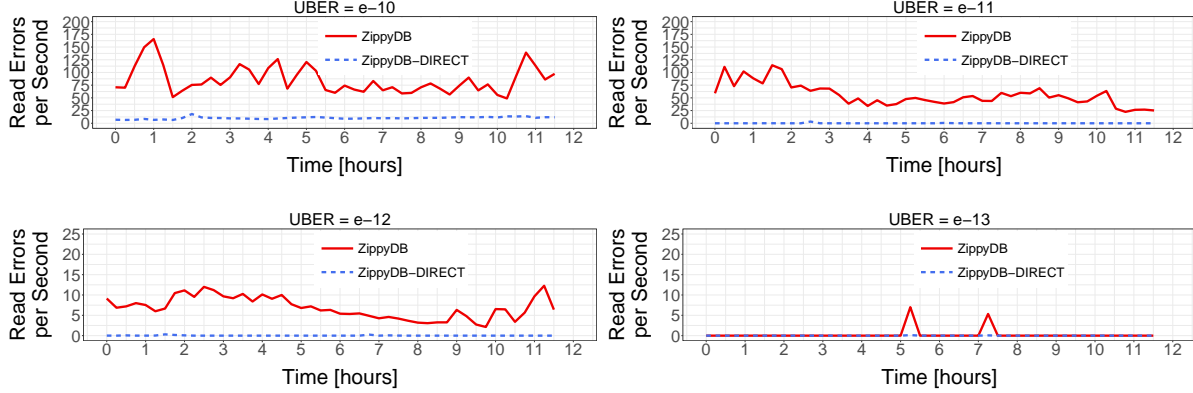

Figure 7: Read error rates over time in ZippyDB and ZippyDB-DIRECT, for a variety of UBERs.

UBER	Compaction Errors per Hour per Server
10^{-10}	0.1991 ± 0.1077
10^{-11}	0.0621 ± 0.0455
10^{-12}	0.0038 ± 0.0035
10^{-13}	0.0003 ± 0.0005

Table 2: Number of compaction errors encountered by ZippyDB. ZippyDB-DIRECT is able to fix these errors, while the server crashes in ZippyDB.

hours rather than several days (or years)².

5.1 ZippyDB

UBER Tolerance. One main difference between unmodified ZippyDB and ZippyDB-DIRECT is that ZippyDB-DIRECT avoids crashing when encountering a bit error. To characterize how many server crashes are mitigated with DIRECT, we measured the average rate of compaction errors per hour *per server*, over 12 hours. The results are shown in Table 2. Figure 7 shows the read error rate over time of both systems for a variety of UBERs. Note that the error rate patterns across UBERs are different because they are run during different time intervals, so each UBER experiment sees different traffic. The error rate is much higher for ZippyDB than ZippyDB-DIRECT because not only do clients see errors from regular read operations, but also they experience the spike in errors when a server shuts down due to a compaction corruption. This is true across the range of evaluated UBERs.

Time Spent in Reduced Durability. With DIRECT, we also seek to minimize the amount of time spent in reduced durability to decrease the likelihood of simultaneous replica failures. Figure 8 shows a CDF of the time it takes to recover from compaction errors in ZippyDB-DIRECT. The graph shows the amount of time it takes

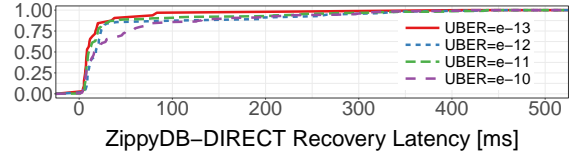

Figure 8: CDF of compaction recovery latencies in ZippyDB-DIRECT. ZippyDB-DIRECT takes milliseconds to recover from corruptions, while ZippyDB takes *minutes*.

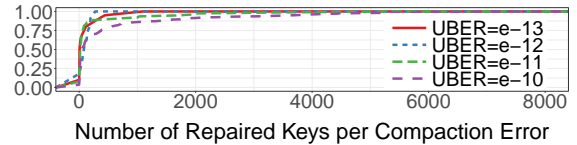

Figure 9: CDF of patch sizes generated during the ZippyDB-DIRECT recovery process. The patch size is small, which means low error amplification.

for replicas to process the Paxos log up until the patch request, as well as the overhead of constructing and inserting the patch. With DIRECT, this recovery time is on the order of *milliseconds*.

In contrast, the period of reduced durability in unmodified ZippyDB due to a compaction error is on the order of *minutes*, depending on the amount of data stored in the crashed ZippyDB server. This is directly due to the high error amplification of ZippyDB, which invalidates 100s of RocksDB shards due to a single compaction bit error. With DIRECT, ZippyDB can reduce its recovery time due to a bit error by around 10,000x!

We also found that the recovery latency is dependent on the size of the patch required to correct the corrupted key range. Figure 9 presents a CDF of the size of the patches generated during the recovery process. Patch size is also interesting because the recovery mechanism described in Section 4.1.4 recovers a *range* of keys, since the exact keys on the corrupted data block are impossible to identify. As we see in Figure 9, even though recover-

² Note that an UBER 10^{-11} is 10,000x *higher* than 10^{-15}

UBER	ZippyDB (CPU consumption)	ZippyDB-DIRECT (CPU consumption)
10^{-10}	100%	80%
10^{-11}	100%	51%
10^{-12}	100%	51%

Table 3: CPU consumption of ZippyDB and ZippyDB-DIRECT (lower is better), normalized to ZippyDB.

ing a range can in theory increase error amplification, the number of keys required for recovery is still low.

Figure 9 also confirms that as the UBER increases, patch sizes increase due to more key ranges getting corrupted during a single compaction operation.

Reduced CPU Consumption. Due to its more efficient recovery from bit corruptions, ZippyDB-DIRECT consumes much less CPU than ZippyDB, as shown in Table 3. We don’t report statistics for $UBER = 10^{-13}$ because the errors are infrequent. CPU usage is higher in ZippyDB mostly due to handling redirected client requests as well as shard restarts.

5.2 HDFS

UBER Tolerance. The main advantage of HDFS-DIRECT over HDFS is the ability to tolerate much higher UBERs with chunk-level recovery. Figure 10 reports block read error rates of HDFS with varying UBERs. This read error is also considered *data loss* in HDFS, because the data is unreadable (and hence unrecoverable) even after trying all 3 replicas. The figure shows both the measured read error on our HDFS experimental setup, as well as the computed read error based on the computation presented in §3.1. The experimental read error is collected by running thousands of file reads and measuring how many fail. Within the UBER range in which we could effectively measure errors, the read errors we measured were similar to the computed results. We do not present experimental read error rates for HDFS-DIRECT, because the read error rates are too low to be measured for the UBERs tested in Figure 10. The figure also presents the expected error rates for HDFS-DIRECT using chunk-by-chunk recovery and bit-by-bit majority. As expected, bit-by-bit majority reduces the read error rate due to its lower error amplification (it can recover bit-by-bit). Both our analysis and the experimental results show that HDFS-DIRECT can tolerate a 10,000-100,000x higher UBER and maintain the same read error rate!

Overhead of DIRECT. Table 4 shows the throughput of both systems, measured by saturating the DataNodes with four, 64-threaded clients that are continuously reading random files. The throughput of HDFS goes to zero at an UBER of 10^{-8} , because it cannot complete any

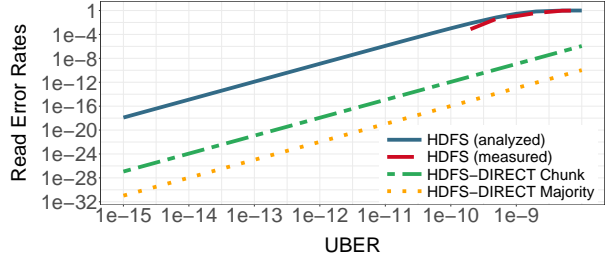

Figure 10: Read error rate for HDFS with varying UBER. The HDFS (analyzed), HDFS-DIRECT Chunk and HDFS-DIRECT Majority are all computed using the formula in §3.1. HDFS-DIRECT Chunk is based on chunk-by-chunk recovery, while HDFS-DIRECT Majority is computed on bit-by-bit majority. Bit-by-bit majority provides lower error rates due to its lower recovery amplification. HDFS (Measured) is the measured HDFS read errors. With HDFS-DIRECT we could not measure any level of read errors until UBERs of 10^{-4} .

UBER	HDFS throughput [GB/s]	HDFS-DIRECT throughput [GB/s]
10^{-7}	0.00 ± 0.00	2.09 ± 0.08
10^{-8}	0.00 ± 0.00	2.56 ± 0.09
10^{-9}	2.46 ± 0.08	2.55 ± 0.07
10^{-10}	2.89 ± 0.10	2.84 ± 0.07
No errors	2.83 ± 0.07	2.88 ± 0.07

Table 4: Throughput of HDFS and HDFS-DIRECT. At $UBER = 10^{-8}$, HDFS throughput collapses due to bit errors.

reads due to corruption errors. Such failures do not occur in HDFS-DIRECT, although its throughput decreases modestly as UBER increases due to the overhead of synchronously repairing corrupt chunks during reads.

For HDFS-DIRECT, we are also interested in latency incurred by synchronous chunk recovery. We compare the CDF of read latencies of 128 MB blocks for different UBERs in Figure 11. The higher the UBER, the more chunk recovery requests that need to be made during a block read and the longer these requests will take. The results in Figure 11 (and Table 4) highlight the fine-grained tradeoff between performance and recoverability that is exposed by DIRECT. We also report HDFS read latencies, but there is little difference across UBERs because only latency for successful block reads are included. Note that the CDF for HDFS does not include UBERs higher than 10^{-8} , since at those error rates HDFS cannot read a block without an error.

6 Discussion

Local File System Error Tolerance. Distributed storage systems run on top of local file systems. Therefore, when devices exhibit higher UBERs, local file systems also experience higher UBERs. DIRECT protects application-level metadata and data, which are just data

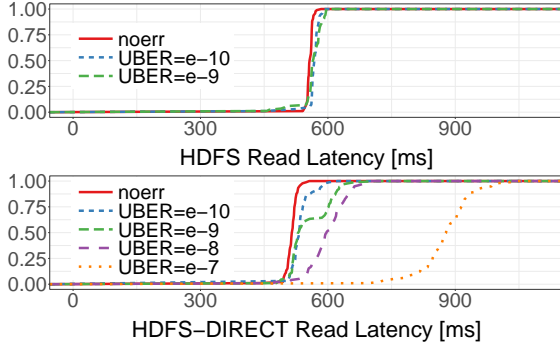

Figure 11: Read latencies (128 MB) of HDFS and HDFS-DIRECT. All reads fail in HDFS an UBER of 10^{-8} and higher.

blocks at the local file system level. Protecting local file system metadata (such as inodes, the FS journal, etc.) is beyond the scope of this paper. Several existing file systems protect metadata against bit corruptions [2, 15, 16, 32, 41, 55, 62]. The general approach is to add checksums to file system metadata and locally replicate it for error correction. Another approach is to use more reliable hardware for metadata, and less reliable hardware for data blocks [41].

Support for DIRECT. DIRECT does not require any hardware support. However, a couple of simple device-level mechanisms would help datacenter operators run devices past their manufacturer defined UBER. First, it would be beneficial if devices have a less aggressive “bad block policy”, which is a firmware protocol for retiring blocks once they reach some heuristic-defined level of errors. Second, it would be beneficial if devices return the content of pages, even if they have an error. This enables distributed storage applications to minimize their recovery amplification, since they can recover data at a granularity smaller than a device page (e.g., on a bit-by-bit level using majority voting). This is not a hard requirement, since as we showed in §3.1 even recovering at a device page level (e.g., 4-8 KB) provides significant benefits. In case corrupt pages cannot be read, it is important to guarantee that when duplicating metadata the copies are stored on separate physical pages. Otherwise, a page error could invalidate all copies of the metadata.

7 Related Work

Related work is divided into two main parts: systems that deal with device errors using software mechanisms or by applying more aggressive hardware mechanisms.

Software-level Redundancy. DIRECT is related to Protocol Aware Recovery (PAR) [18], which recently demonstrated how consensus-based protocols can be adapted to address bit-level errors. Unlike PAR, which only addresses consensus protocols, our work tackles bit-level errors in general purpose storage systems. We also

show how increasing the resiliency to bit-level errors can significantly reduce storage costs and improve live recovery speed in datacenter environments.

FlexECC [35] and Duracache [46] are flash-based key-value caches that use less reliable disks by treating devices errors as cache misses. D-GRAID is a RAID storage system that gracefully degrades by minimizing the amount of data needed to recover from bit corruptions [58]. There is a large number of distributed storage systems that use inexpensive, unreliable hardware, while providing consistency and reliability guarantees [21, 26, 30]. However, these systems treat bit corruptions similar to entire-node failures and suffer from high recovery amplification.

There is a large body of work on finding errors in the way both local file systems and distributed file systems handle disk corruptions [29]. These efforts are orthogonal to our work, because they focus on correctness flaws of existing systems under disk corruptions, while we focus on how far we can push disk error rates without compromising performance (while maintaining correctness). Research on hardening local file systems to tolerate disk errors supports our vision of less reliable disks, because it shows that it is possible to protect a local file system from disk bit errors [2, 15, 16, 32, 41, 55, 62].

Hardware-level Redundancy. Several studies explore extending SSD lifetime via more aggressive or adaptive hardware error correction. Tanakamura *et al.* [60] propose adapting codeword size based on the SSD’s dynamic device wear level to improve SSD lifetime. Cai *et al.* [25] and Liu *et al.* [47] introduce techniques to dynamically learn and adjust the cell voltage levels based on retention age. Zhao *et al.* [64] propose using the soft information with LDPC error correction to increase lifetime. Our approach is different: instead of improving hardware-based error correction, we leverage existing software-based redundancy to address bit-level errors.

8 Conclusion

This paper presents DIRECT, a set of policies that use the inherent redundancy that exists in distributed storage applications for live recovery of bit corruptions.

We can extend the approach of handling error correction in the distributed storage layer in several directions. First, distributed storage systems can control the level of error correction depending on data type. For example, some data types may be more sensitive to bit corruptions (e.g., critical metadata), while others may not. Second, distributed storage system can control hardware mechanisms that influence the performance of the device. For example, storing fewer bits per cell generally reduces the latency of the device (at the expense of its capacity). Certain applications may prefer to use a hybrid of low latency and low capacity devices for hot data, while re-

servicing the high capacity devices for colder data.

References

- [1] DRAM prices continue to climb. <https://epsnews.com/2017/08/18/dram-prices-continue-climb/>.
- [2] Ext4 metadata checksums. <https://blogs.msdn.microsoft.com/b8/2012/01/16/building-the-next-generation-file-system-for-windows-refs/>.
- [3] HDFS high availability. <https://hadoop.apache.org/docs/stable/hadoop-project-dist/hadoop-hdfs/HDFSHighAvailabilityWithNFS.html>.
- [4] High-efficiency SSD for reliable data storage systems. https://www.flashmemorysummit.com/English/Collaterals/Proceedings/2011/20110810_T2A_Yang.pdf.
- [5] Introducing Lightning: A flexible NVMe JBOF. <https://code.facebook.com/posts/989638804458007/introducing-lightning-a-flexible-nvme-jbof/>.
- [6] LevelDB. <http://leveldb.org>.
- [7] McDipper: A key-value cache for flash storage. <https://www.facebook.com/notes/facebook-engineering/mcdipper-a-key-value-cache-for-flash-storage/10151347090423920/>.
- [8] Novel 4k error correcting code for QLC NAND. https://www.flashmemorysummit.com/English/Collaterals/Proceedings/2017/20170809_FE22_Kuo.pdf.
- [9] Project Voldemort: A distributed key-value storage system. <http://www.project-voldemort.com/voldemort>.
- [10] RocksDB. <http://rocksdb.org>.
- [11] RocksDB block based table format. <https://github.com/facebook/rocksdb/wiki/Rocksdb-BlockBasedTable-Format>.
- [12] SanDisk Datasheet. https://www.sandisk.com/business/datacenter/resources/datasheets/fusion-iomemory-sx350_datasheet.
- [13] Under the hood: Building and open-sourcing RocksDB. <http://www.facebook.com/notes/facebook-engineering/under-the-hood-building-and-open-sourcing-rocksdb/10151822347683920>.
- [14] What is R.A.I.S.E? <https://www.kingston.com/us/ssd/raise>.
- [15] XFS reliable detection and repair of metadata corruption. http://xfs.org/index.php/Reliable_Detection_and_Repair_of_Metadata_Corruption.
- [16] The Z File System (ZFS). <https://www.freebsd.org/doc/handbook/zfs.html>.
- [17] NAND flash media management through RAIN. Technical report, Micron, 2013.
- [18] R. Alagappan, A. Ganesan, E. Lee, A. Albarghouthi, V. Chidambaram, A. C. Arpaci-Dusseau, and R. H. Arpaci-Dusseau. Protocol-aware recovery for consensus-based storage. In *16th USENIX Conference on File and Storage Technologies (FAST 18)*, pages 15–32, Oakland, CA, 2018. USENIX Association.
- [19] C. Albrecht, A. Merchant, M. Stokely, M. Waliji, F. Labelle, N. Coehlo, X. Shi, and E. Schrock. Janus: Optimal flash provisioning for cloud storage workloads. In *USENIX Annual Technical Conference*, pages 91–102, 2013.
- [20] P. Alcorn. Facebook asks for QLC NAND, Toshiba answers with 100TB QLC SSDs with TSV. <http://www.tomshardware.com/news/qlc-nand-ssd-toshiba-facebook,32451.html>.
- [21] D. G. Andersen, J. Franklin, M. Kaminsky, A. Phanishayee, L. Tan, and V. Vasudevan. FAWN: A fast array of wimpy nodes. In *Proceedings of the ACM SIGOPS 22Nd Symposium on Operating Systems Principles, SOSP '09*, pages 1–14, New York, NY, USA, 2009. ACM.
- [22] D. Borthakur. HDFS block replica placement in your hands now! <http://hadoopblog.blogspot.com/2009/09/hdfs-block-replica-placement-in-your.html>.
- [23] E. Brewer, L. Ying, L. Greenfield, R. Cypher, and T. T'so. Disks for data centers. Technical report, Google, 2016.
- [24] Y. Cai, E. F. Haratsch, O. Mutlu, and K. Mai. Error patterns in MLC NAND flash memory: Measurement, characterization, and analysis. In *Proceedings of the Conference on Design, Automation and Test in Europe*, pages 521–526, Dresden, Germany, 2012.
- [25] Y. Cai, Y. Luo, E. F. Haratsch, K. Mai, and O. Mutlu. Data retention in MLC NAND flash memory: Characterization, optimization, and recovery. In *Proceedings of the 21st International Symposium on High Performance Computer Architecture*, pages 551–563, San Francisco, CA, 2015.
- [26] G. DeCandia, D. Hastorun, M. Jampani, G. Kakulapati, A. Lakshman, A. Pilchin, S. Sivasubramanian, P. Voshall, and W. Vogels. Dynamo: Amazon's Highly Available Key-value Store. *SIGOPS Operating Systems Review*, 41(6):205–220, Oct. 2007.
- [27] A. Eisenman, D. Gardner, I. AbdelRahman, J. Axboe, S. Dong, K. M. Hazelwood, C. Petersen, A. Cidon, and S. Katti. Reducing DRAM footprint with NVM in facebook. In *Proceedings of the Thirteenth EuroSys Conference, EuroSys 2018, Porto, Portugal, April 23-26, 2018*, pages 42:1–42:13, 2018.
- [28] D. Exchange. DRAM supply to remain tight with its annual bit growth for 2018 forecast at just 19.6. www.dramexchange.com.
- [29] A. Ganesan, R. Alagappan, A. C. Arpaci-Dusseau, and R. H. Arpaci-Dusseau. Redundancy does not imply fault tolerance: Analysis of distributed storage reactions to single errors and corruptions. In *15th USENIX Conference on File and Storage Technologies*, pages 149–166, Santa Clara, CA, 2017. USENIX Association.
- [30] S. Ghemawat, H. Gobioff, and S.-T. Leung. The Google File System. In *Proceedings of the Nineteenth ACM Symposium on Operating Systems Principles, SOSP '03*, pages 29–43, New York, NY, USA, 2003. ACM.
- [31] L. M. Grupp, J. D. Davis, and S. Swanson. The bleak future of NAND flash memory. In *Proceedings of the 10th USENIX Conference on File and Storage Technologies*, pages 17–24, San Jose, CA, 2012.

- [32] H. S. Gunawi, V. Prabhakaran, S. Krishnan, A. C. Arpaci-Dusseau, and R. H. Arpaci-Dusseau. Improving file system reliability with i/o shepherding. In *Proceedings of Twenty-first ACM SIGOPS Symposium on Operating Systems Principles, SOSOP '07*, pages 293–306, New York, NY, USA, 2007. ACM.
- [33] T. Harter, D. Borthakur, S. Dong, A. Aiyer, L. Tang, A. C. Arpaci-Dusseau, and R. H. Arpaci-Dusseau. Analysis of HDFS under HBase: A Facebook messages case study. In *Proceedings of the 12th USENIX Conference on File and Storage Technologies*, pages 199–212, Santa Clara, CA, 2014.
- [34] C. Huang, H. Simitci, Y. Xu, A. Ogus, B. Calder, P. Gopalan, J. Li, S. Yekhanin, et al. Erasure coding in Windows Azure Storage. In *Usenix annual technical conference*, pages 15–26. Boston, MA, 2012.
- [35] P. Huang, P. Subedi, X. He, S. He, and K. Zhou. FlexECC: Partially relaxing ECC of MLC SSD for better cache performance. In *Proceedings of the 2014 USENIX Annual Technical Conference*, pages 489–500, Philadelphia, PA, 2014.
- [36] J. Jeong, S. S. Hahn, S. Lee, and J. Kim. Lifetime improvement of NAND flash-based storage systems using dynamic program and erase scaling. In *FAST*, pages 61–74, 2014.
- [37] K. Kambatla and Y. Chen. The truth about MapReduce performance on SSDs. In *Proceedings of the 28th Large Installation System Administration Conference*, pages 118–126, Seattle, WA, 2014.
- [38] U. Kang, H.-s. Yu, C. Park, H. Zheng, J. Halbert, K. Bains, S. Jang, and J. S. Choi. Co-architecting controllers and DRAM to enhance DRAM process scaling. In *The memory forum*, pages 1–4, 2014.
- [39] H. Kim, S.-J. Ahn, Y. G. Shin, K. Lee, and E. Jung. Evolution of NAND flash memory: From 2D to 3D as a storage market leader. In *Memory Workshop (IMW), 2017 IEEE International*, pages 1–4. IEEE, 2017.
- [40] J. Lee, J. Jang, J. Lim, Y. G. Shin, K. Lee, and E. Jung. A new ruler on the storage market: 3D-NAND flash for high-density memory and its technology evolutions and challenges on the future. In *Electron Devices Meeting (IEDM), 2016 IEEE International*, pages 11–2. IEEE, 2016.
- [41] S. Lee, K. Ha, K. Zhang, J. Kim, and J. Kim. FlexFS: A flexible flash file system for MLC NAND flash memory. In *Proceedings of the 2009 Conference on USENIX Annual Technical Conference, USENIX'09*, pages 9–9, Berkeley, CA, USA, 2009. USENIX Association.
- [42] S.-H. Lee. Technology scaling challenges and opportunities of memory devices. In *Electron Devices Meeting (IEDM), 2016 IEEE International*, pages 1–1. IEEE, 2016.
- [43] C. Li, P. Shilane, F. Douglass, H. Shim, S. Smaldone, and G. Wallace. Nitro: A capacity-optimized SSD cache for primary storage. In *Proceedings of the 2014 USENIX Annual Technical Conference*, pages 501–512, 2014.
- [44] C. Li, P. Shilane, F. Douglass, and G. Wallace. Pannier: A container-based flash cache for compound objects. In *Proceedings of the 16th Annual Middleware Conference*, pages 50–62, Vancouver, BC, 2015.
- [45] H. Lim, B. Fan, D. G. Andersen, and M. Kaminsky. SILT: A memory-efficient, high-performance key-value store. In *Proceedings of the Twenty-Third ACM Symposium on Operating Systems Principles, SOSOP '11*, pages 1–13, New York, NY, USA, 2011.
- [46] R. Liu, C. Yang, C. Li, and G. Chen. DuraCache: a durable SSD cache using MLC NAND flash. In *Proceedings of the 50th Annual Design Automation Conference 2013*, pages 166–171, Austin, TX, 2013.
- [47] R.-S. Liu, C.-L. Yang, and W. Wu. Optimizing NAND flash-based SSDs via retention relaxation. In *Proceedings of the 10th USENIX conference on File and Storage Technologies*, San Jose, CA, 2012.
- [48] L. Lu, T. S. Pillai, A. C. Arpaci-Dusseau, and R. H. Arpaci-Dusseau. WiscKey: Separating keys from values in SSD-conscious storage. In *14th USENIX Conference on File and Storage Technologies (FAST 16)*, pages 133–148, Santa Clara, CA, Feb. 2016.
- [49] C. Mellor. Toshiba flashes 100TB QLC flash drive, may go on sale within months. really. http://www.theregister.co.uk/2016/08/10/toshiba_100tb_qlc_ssd/.
- [50] J. Meza, Q. Wu, S. Kumar, and O. Mutlu. A large-scale study of flash memory failures in the field. In *Proceedings of the 2015 ACM SIGMETRICS International Conference on Measurement and Modeling of Computer Systems*, pages 177–190, Portland, Oregon, 2015.
- [51] R. Micheloni et al. *3D Flash memories*. Springer, 2016.
- [52] S. Ohshima and Y. Tanaka. New 3D flash technologies offer both low cost and low power solutions. <https://www.flashmemorysummit.com/English/Conference/Keynotes.html>.
- [53] J. Ouyang, S. Lin, S. Jiang, Z. Hou, Y. Wang, and Y. Wang. SDF: Software-defined flash for web-scale Internet storage systems. *SIGARCH Computing Architecture News*, 42(1):471–484, 2014.
- [54] P. O’Neil, E. Cheng, D. Gawlick, and E. O’Neil. The log-structured merge-tree (lsm-tree). *Acta Informatica*, 33(4):351–385, 1996.
- [55] V. Prabhakaran, L. N. Bairavasundaram, N. Agrawal, H. S. Gunawi, A. C. Arpaci-Dusseau, and R. H. Arpaci-Dusseau. Iron file systems. In *Proceedings of the twentieth ACM symposium on Operating systems principles*, 2005.
- [56] M. Sathiamoorthy, M. Asteris, D. Papailiopoulos, A. G. Dimakis, R. Vadali, S. Chen, and D. Borthakur. XORing elephants: Novel erasure codes for big data. In *Proceedings of the 39th International Conference on Very Large Data Bases*, pages 325–336, Trento, Italy, 2013.
- [57] B. Schroeder, R. Lagisetty, and A. Merchant. Flash reliability in production: The expected and the unexpected. In *Proceedings of the 14th USENIX Conference on File and Storage Technologies*, pages 67–80, Santa Clara, CA, 2016.
- [58] M. Sivathanu, V. Prabhakaran, A. C. Arpaci-Dusseau, and R. H. Arpaci-Dusseau. Improving storage system availability with D-GRAID. *Trans. Storage*, 1(2):133–170, May 2005.
- [59] A. S. Spinelli, C. M. Compagnoni, and A. L. Lacaita. Reliability of NAND flash memories: Planar cells and emerging issues in 3D devices. *Computers*, 6(2):16, 2017.
- [60] S. Tanakamaru, M. Fukuda, K. Higuchi, A. Esumi, M. Ito, K. Li, and K. Takeuchi. Post-manufacturing, 17-times acceptable raw bit error rate enhancement, dynamic codeword transition ECC scheme for highly reliable solid-state drives, SSDs. *Solid-State Electronics*, 58(1):2–10, 2011.

- [61] L. Tang, Q. Huang, W. Lloyd, S. Kumar, and K. Li. RIPQ: Advanced photo caching on flash for Facebook. In *Proceedings of the 13th USENIX Conference on File and Storage Technologies*, pages 373–386, Santa Clara, CA, 2015.
- [62] J. Xu and S. Swanson. NOVA: A log-structured file system for hybrid volatile/non-volatile main memories. In *14th USENIX Conference on File and Storage Technologies (FAST 16)*, pages 323–338, Santa Clara, CA, 2016. USENIX Association.
- [63] G. Zemor and G. D. Cohen. Error-correcting WOM-codes. *IEEE Transactions on Information Theory*, 37(3):730–734, 1991.
- [64] K. Zhao, W. Zhao, H. Sun, X. Zhang, N. Zheng, and T. Zhang. LDPC-in-SSD: Making advanced error correction codes work effectively in solid state drives. In *Presented as part of the 11th USENIX Conference on File and Storage Technologies (FAST 13)*, pages 243–256, San Jose, CA, 2013.