

A $\mathbf{k} \cdot \mathbf{p}$ treatment of edge states in narrow 2D topological insulators, with standard boundary conditions for the wave function and its derivative

P.C. Klipstein

Semiconductor Devices, P.O. Box 2250, Haifa 31021, Israel

Abstract

For 2D topological insulators with strong electron-hole hybridization, such as HgTe/CdTe quantum wells, the widely used 4×4 toy Hamiltonian based on $\mathbf{k} \cdot \mathbf{p}$ theory yields an equal number of physical and spurious solutions, for both the bulk states and the edge states. For symmetric bands and zero wave vector parallel to the sample edge, the mid-gap bulk solutions are identical to the edge solutions. In all cases, the physical edge solution is exponentially localized to the boundary and has been shown previously to satisfy standard boundary conditions for the wave function and its derivative, even in the limit of an infinite wall potential. The same treatment is now extended to the case of narrow sample widths, where for each spin direction, a gap appears in the edge state dispersions. For widths greater than 200 nm, this gap is less than half of the value reported for open boundary conditions, which are called into question because they include a spurious wave function component. The gap in the edge state dispersions is also calculated for weakly hybridized InAs/GaSb/AlSb quantum wells. In contrast to the strongly hybridized case, the edge states at the zone center only have pure exponential character when the bands are symmetric and when the sample has certain characteristic width values.

PACS numbers: 73.21.-b, 73.23.-b, 73.61.Ey, 73.61.Ga

I. INTRODUCTION

Semiconductor quantum wells (QWs) containing elements with a large atomic number have both a narrow bandgap and a large spin-orbit splitting. For layer thicknesses greater than a critical value it is often possible to reverse the ordering of the s - and p -symmetry confined states so that the material undergoes a transition to a two dimensional topological insulator phase¹. Since the spin-orbit splitting is also large, the topological phase can develop a significant band gap remote from other states, whereby the bulk material is an insulator at low temperatures, while the edges conduct massless Dirac Fermions whose spin is locked to their direction of motion. Two prime examples are HgTe/CdTe² and InAs/GaSb/AlSb³. Their band profiles with an inversion of the s - and p - states are shown schematically in Figure 1. These materials exhibit properties such as the quantum spin Hall effect^{4,5} where opposite spins are separated to different edges of a bar shaped sample. The edge conductance is also quantized in units of e^2/h per edge.

The growth of II-VI Hg_{1-x}Cd_xTe/CdTe QWs is very challenging, due to their low growth temperatures and material quality issues⁶. On the other hand III-V InAs/GaSb/AlSb QWs can be grown with high quality, and superlattices based on these materials are currently being developed both academically and commercially for various applications including as photodetector and laser materials.^{7,8} Therefore, the III-V material is likely to be more accessible to a wider range of institutions for the study of topological phenomena. Moreover, recent reports have shown that in spite of their smaller topological insulator band gaps, III-V QWs show remarkably robust edge states with properties not inferior to those of II-VI QWs. For example, a very precise quantized conductance has been reported in InAs/GaSb/AlSb QWs that persists up to about 5 K⁹, and the edge state coherence length appears to be several microns.¹⁰

A significant difference between the II-VI and III-V QWs is the strength of the electron hole hybridization which, due to its type II band alignment, is about an order of magnitude weaker in the III-V system. As shown previously using $\mathbf{k}\cdot\mathbf{p}$ theory, this results in wave functions whose different character may perhaps account for some of the differences observed in the physical behavior of the two topological insulator materials.^{11,12} In the II-VI material the wave function decays monotonically with distance from the edge, while in the III-V material it decays faster and oscillates. The previous work treated a single edge of a QW with a semi-infinite sample width. In the present work the treatment is extended to narrow sample widths, where states from opposite edges begin to overlap. It was shown by Zhou et al., that for sufficiently narrow HgTe/CdTe samples, a gap opens up in the edge state dispersions.¹³ Their analysis used open boundary conditions (OBCs) which impose zero amplitude on the wave function at the sample edge. As argued previously and in this work, such an approach can lead to unphysical results because spurious "wing" solutions are combined with real physical solutions in order to satisfy the zero amplitude condition.¹⁴

In this work the problem of interacting edge states in narrow width samples is readdressed using standard boundary conditions (SBCs) for the physical wave function and its derivative. It was shown previously that SBCs can be satisfied by exponentially localized edge states, even when the potential of the sample wall is infinite.^{11,12} For narrow strongly hybridized QWs, the gap in the edge state dispersion is significantly smaller than that found using OBCs. This gap is also calculated for narrow weakly hybridized systems, using parameters typical of InAs/GaSb/AlSb quantum wells. In contrast to the strongly hybridized case, the edge states in weakly hybridized systems with symmetric band dispersions only decay exponentially for certain edge state wave vectors close to the zone center and certain equally spaced sample widths. When the dispersions are asymmetric there are no exponential

solutions, i.e. the decay is non-exponential, but in all cases exponential character is re-established close to the merging points of the edge states with the bulk band edges.

II. MODEL HAMILTONIAN

A 4×4 block-diagonal $\mathbf{k} \cdot \mathbf{p}$ Hamiltonian for a 2D topological insulator QW sample has been described in several previous works.^{2,11,13} Considering only spin up states, a 2×2 wave equation can be taken from its upper block as follows:

$$\begin{bmatrix} M + B_+ (k_x^2 + k_y^2) & A(k_x + ik_y) \\ A(k_x - ik_y) & -M - B_- (k_x^2 + k_y^2) \end{bmatrix} \begin{bmatrix} \psi_{1\uparrow} \\ \psi_{2\uparrow} \end{bmatrix} = E \begin{bmatrix} \psi_{1\uparrow} \\ \psi_{2\uparrow} \end{bmatrix} \quad (1)$$

The equivalent 2×2 wave equation for spin down states is taken from the lower block, although its solutions can be obtained from Eq. (1) by time reversal. In Eq. (1) $B_{\pm} = B \pm D$, where $B > 0$, $D > 0$ and in the topological phase, $M < 0$. In the wall regions at the boundaries of the sample $B = B_0$, $D = D_0$, $A = A_0$ and $M = M_0 > 0$. As in previous works, Eq. (1) will be solved for the edge states in the limit $B_0 = D_0 = 0$, when the wall obeys a relativistic Hamiltonian with energies: $E = \pm \sqrt{p^2 c^2 + m_0^2 c^4}$, where $p^2 c^2 = A_0^2 (k_x^2 + k_y^2)$ and $m_0 c^2 = M_0$. For $M_0 \rightarrow \infty$, the wall provides an infinite confining potential for both electrons and holes¹¹.

Previously,^{11,12} Eq. (1) was solved with $A_0 = A$. This toy model implicitly assumes that the crystal periodic basis states are the same in both the sample and the wall, and all other crystal periodic basis states are extremely remote.^{15,16} It avoids having to know the ordering of the off-diagonal electron-hole hybridization operators, since there are no "interface" contributions at the sample edges due to operator ordering. In principal any residual δ -function like edge terms of the type discussed in

Refs. 15 and 16 can be included as a perturbation, as discussed at the end of section 2 of Ref. 12. However, since the edge states penetrate the sample over much greater distances than the bulk lattice constant, it will be assumed that their amplitude at the edge is small enough that such edge terms can be ignored.

Since the wall potential, M_0 , is very different from the M -value in the sample, it is probably a better assumption to suppose that the A -parameters in the sample and wall are also different. Realistic wall parameters cannot be derived through perturbation theory, so a more phenomenological approach must be taken. In the following treatment, most results are presented for the simpler case of $A_0 = A$, but the effect of different A -values in the sample and wall regions is also investigated. In all cases, interface contributions from the edges are neglected. Fortunately, even when $A_0 = \hbar c \gg A$ (corresponding to a totally free particle), the results for strongly hybridized HgTe/CdTe QWs are virtually the same as for $A_0 = A$. For weakly hybridized systems with symmetric bands ($D = 0$), the results are totally independent of A_0 .

III. BOUNDARY CONDITIONS

Eq. (1) with $D = 0$ and $k_x = 0$ corresponds directly with the 2×2 $\mathbf{k} \cdot \mathbf{p}$ Hamiltonian of White and Sham¹⁷ who showed that it produces two pairs of bulk evanescent states in the band gap energy range, $|M| > E > -|M|$, one of which they termed the "wing" bands and the other the "middle" bands. The "middle" bands are physical evanescent states with small imaginary wave vector, $iq_m(E) \approx \pm i \sqrt{(M - E)(M + E)} / A$, that correspond, for example, to a physically decaying wave function when the material is used as a barrier in a tunnel structure. The "wing" bands, on the other hand, do not describe any real physical states. For small B their imaginary wave vectors are

$iq_w(E) \rightarrow \pm i \frac{A}{B}$ and can become very large, with a magnitude that can even go beyond the first Brillouin zone boundary. They are a mathematical necessity for matching the boundary conditions on the wave-function and its derivative, but do not exist in a more complete solution involving a larger set of basis states.¹⁸

Topological arguments show that for $M_0 \rightarrow +\infty$, $M < 0$, $D = 0$, Eq. (1) has a spin polarized edge solution with energy $-Ak_x$ (the equivalent spin down solution is $+Ak_x$).^{4,19} When B is non-zero, there are actually two edge solutions of Eq. (1) which have wave functions at zero energy and wave vector proportional to $\begin{bmatrix} 1 \\ -1 \end{bmatrix} e^{-q_m(0)y}$ and $\begin{bmatrix} 1 \\ -1 \end{bmatrix} e^{-q_w(0)y}$, since the evanescent edge solutions of Eq. (1) at $k_x = 0$ are no different from the bulk case, discussed above. A common procedure is to apply OBCs for an edge at $y = 0$, yielding a single wave function at $k_x = 0$ of the form $\begin{bmatrix} 1 \\ -1 \end{bmatrix} \left(e^{-q_m(0)y} - e^{-q_w(0)y} \right)$ which has zero amplitude at the edge.^{13, 20, 21} Unfortunately, this procedure is not valid since the physical "middle" solution is combined with the unphysical "wing" solution that would not exist in a more complete treatment, as discussed above. Moreover, for non-zero D , there is still a middle solution, and a spurious evanescent "wing" solution which becomes a spurious oscillatory solution in materials with $D > B$, as first pointed out by Schuurmans and t'Hooft.¹⁸ There is then no edge solution that satisfies OBCs, yet Schuurmans and t'Hooft argued that precisely this condition occurs in many bulk materials (e.g. GaAs and AlAs)¹⁸, and the author previously showed that $D > B$ also applies to HgTe/CdTe QWs¹¹. Finally, for $B = D = 0$, there are no wing solutions and only one edge solution with a decay parameter, $q_m(0) = \pm M/A$.^{12,14,19} In this case it is impossible to satisfy OBCs so they have no solution.

Some other non-physical consequences of OBC solutions have been discussed by the author in more detail in Ref. 12. The "spurious" or "wing" solution must therefore be rejected, and an alternative

treatment is required for a wave function with a finite amplitude at the edge. This wave function must satisfy boundary conditions which take the wall region into account. These boundary conditions, termed SBCs in the previous section, are derived for the wave function and its derivative by integrating Eq. (1) across the wall region. For a wall Hamiltonian as defined in section II, and an edge at $y = 0$, the SBCs are:

$$\begin{aligned} \psi_{1,2\uparrow}|_{-\varepsilon} &= \psi_{1,2\uparrow}|_{+\varepsilon} & (a) \\ B_{0\pm} \frac{\partial \psi_{1,2\uparrow}}{\partial y} \Big|_{-\varepsilon} &= B_{\pm} \frac{\partial \psi_{1,2\uparrow}}{\partial y} \Big|_{+\varepsilon} & (2) \end{aligned} \quad (b)$$

with positive $\varepsilon \rightarrow 0$. Based on this approach, an exponentially decaying solution for the edge of a semi-infinite sample has been derived in two earlier works,^{11,12} in the limit of $M_0 \rightarrow +\infty$, corresponding to a vacuum with an infinite confining potential. In the following section this SBC treatment is extended to edge states in narrow samples of width, $L_S = 2L$ ($-L < y < L$), so that a non-zero edge state amplitude exists on both sample edges.

This section ends with a discussion of some topological aspects of the SBC treatment. For simplicity, it is assumed that the band structure is symmetric ($D_0 = D = 0$). Exponentially confined edge states, with decay parameters, σ_0 and σ , only exist for negative B_0 , since Eq. (2) (b) yields $B_0 = \frac{\sigma}{\sigma_0} B$, and the decay parameters have opposite signs¹¹. A wall with $M_0 > 0$, $B_0 < 0$ and $A_0 > 0$ is a topological phase characterized by a Chern number of -1 , while the sample with $M < 0$, $B > 0$ and $A > 0$ is a topological phase characterized by a Chern number of $+1$. The difference in Chern numbers is two, so there should be two edge state solutions for any negative value of B_0 , guaranteed to propagate in the same direction along the boundary²². In Ref. 11, two analytical solutions were found using the boundary conditions in Eq. (2). In that case, they correspond to a specific value of B_0 because an additional constraint was placed on the energies, namely $E = -Ak_x$ for spin up and $E = +Ak_x$ for spin

down. When the wall becomes a vacuum, with $M_0 \rightarrow \infty$ and $\sigma_0 \rightarrow \infty$, this value of B_0 tends to zero. Since $E = 0$ when $k_x = 0$, one of the two solutions for the infinite wall can be eliminated as a spurious wing solution, as discussed earlier in this section. Although there are no exponential solutions for a wall with positive B_0 (i.e. $M_0 > 0$, $B_0 > 0$ and $A_0 > 0$), such a wall is topologically trivial with a Chern number of zero, so then only one (non-exponential) edge state is predicted. Presumably, when $M_0 = \infty$ and the positive value of B_0 tends to zero, this edge state evolves into the same non-spurious exponential solution discussed above when negative B_0 tends to zero. Finally, the case of $B = B_0 = 0$ has been discussed by Tkachov and Hankiewicz¹⁹ who found a single exponentially decaying solution of Eq. (1) using a condition of zero current perpendicular to the boundary. In the SBC treatment, boundary condition (2) (b) vanishes and Eq. (1) yields a single edge solution identical to that of Tkachov and Hankiewicz, which also corresponds with the non-spurious solution in the same limit. Although each phase in this case is topologically trivial, giving rise to a non-integer Chern number of $\pm 1/2$, the change in Chern number across the boundary is one, consistent with the existence of a single topological edge state.

IV. CHARACTERISTIC EQUATION FOR EDGE STATES IN NARROW SAMPLES

In this section edge state solutions will be sought which are exponentially localized to the sample boundaries, so that the wave function for a narrow sample can be defined as follows:

$$\begin{bmatrix} \psi_{1\uparrow} \\ \psi_{2\uparrow} \end{bmatrix} = \begin{bmatrix} A_1 \cosh \sigma y + B_1 \sinh \sigma y \\ A_2 \cosh \sigma y + B_2 \sinh \sigma y \end{bmatrix} e^{ikx} = \overline{\psi}_{\uparrow, \sigma}(y) e^{ikx} \quad (3)$$

where $k = k_x$ is the edge state wave vector. The constants A_1, B_1, A_2, B_2 are determined by the boundary conditions. Substituting Eq. (3) into Eq. (1), an equation of the form: $\overline{D}\overline{A} = 0$ is obtained where \overline{A} is a

column vector with components: A_1, B_1, A_2, B_2 . Solving $|D|=0$ yields the formula for the decay parameters:

$$\sigma_{\pm} = \sqrt{k^2 + F \pm \sqrt{F^2 - G}} \quad (4)$$

where $F = \frac{A^2 + 2(MB + ED)}{2B_+ B_-}$ and $G = \frac{M^2 - E^2}{B_+ B_-}$. This is identical to the formula derived previously for a single edge.^{11, 12, 23} Decay parameters with a given energy are either both real, real and imaginary, or complex conjugates. Contrary to previous works^{11, 12}, where a prime was added when $D \neq 0$, i.e. σ'_{\pm} , the prime is dropped in the present work and the same symbol, σ_{\pm} , is used in all cases.

The wave functions in the wall region are simple exponentially decaying functions proportional to $\exp(-\sigma_{0L}[y+L])$ for the left hand wall and $\exp(\sigma_{0R}[y-L])$ for the right, where the decay parameters, σ_{0L} and σ_{0R} are both negative and tend to infinity when $M_0 \rightarrow +\infty$. Applying the SBC boundary conditions for the wave function derivatives in Eq.(2)(b) yields the following relation for the coefficients:

$$\frac{A_1}{B_1} = \frac{A_2}{B_2} = -\frac{\sigma - (r_L \sigma_{0L}) \tanh \sigma L}{(r_L \sigma_{0L}) - \sigma \tanh \sigma L} = \frac{\sigma - (r_R \sigma_{0R}) \tanh \sigma L}{(r_R \sigma_{0R}) - \sigma \tanh \sigma L} \quad (5)$$

where $r_L = B_{0L}/B = D_{0L}/D$ and $r_R = B_{0R}/B = D_{0R}/D$. In the limit, $M_0 \rightarrow +\infty$, it is shown below that $r_L \rightarrow 0$ and $r_R \rightarrow 0$, while the products $r_L \sigma_{0L}$ and $r_R \sigma_{0R}$ tend to finite values.

Applying the SBC boundary condition for continuity of the wave-function, and substituting expressions for the wave function into the Hamiltonian equation for the wall, produces the following result in the limit $M_0 \rightarrow +\infty$:

$$\begin{bmatrix}
\left(1 - \frac{\sigma_{0L}^2 B_{0L+}}{M_0}\right) \cosh \sigma L & -\left(1 - \frac{\sigma_{0L}^2 B_{0L+}}{M_0}\right) \sinh \sigma L & -A_0 \left(\frac{\sigma_{0L}}{M_0}\right) \cosh \sigma L & A_0 \left(\frac{\sigma_{0L}}{M_0}\right) \sinh \sigma L \\
-A_0 \left(\frac{\sigma_{0R}}{M_0}\right) \cosh \sigma L & -A_0 \left(\frac{\sigma_{0R}}{M_0}\right) \sinh \sigma L & -\left(1 - \frac{\sigma_{0R}^2 B_{0R-}}{M_0}\right) \cosh \sigma L & -\left(1 - \frac{\sigma_{0R}^2 B_{0R-}}{M_0}\right) \sinh \sigma L \\
A_0 \left(\frac{\sigma_{0L}}{M_0}\right) \cosh \sigma L & -A_0 \left(\frac{\sigma_{0L}}{M_0}\right) \sinh \sigma L & -\left(1 - \frac{\sigma_{0L}^2 B_{0L-}}{M_0}\right) \cosh \sigma L & \left(1 - \frac{\sigma_{0L}^2 B_{0L-}}{M_0}\right) \sinh \sigma L \\
\left(1 - \frac{\sigma_{0R}^2 B_{0R+}}{M_0}\right) \cosh \sigma L & \left(1 - \frac{\sigma_{0R}^2 B_{0R+}}{M_0}\right) \sinh \sigma L & A_0 \left(\frac{\sigma_{0R}}{M_0}\right) \cosh \sigma L & A_0 \left(\frac{\sigma_{0R}}{M_0}\right) \sinh \sigma L
\end{bmatrix}
\begin{bmatrix}
A_1 \\
B_1 \\
A_2 \\
B_2
\end{bmatrix} = 0 \quad (6)$$

The determinant of the square matrix must be zero, which occurs when one of the following two conditions is fulfilled:

$$A_0^2 = \left(\frac{M_0}{\sigma_{0L}} - \sigma_{0L} B_{0L-}\right) \left(\frac{M_0}{\sigma_{0L}} - \sigma_{0L} B_{0L+}\right) \quad (a)$$

$$A_0^2 = \left(\frac{M_0}{\sigma_{0R}} - \sigma_{0R} B_{0R-}\right) \left(\frac{M_0}{\sigma_{0R}} - \sigma_{0R} B_{0R+}\right) \quad (b)$$

These conditions can be rearranged to give:

$$\left(\frac{M_0}{\sigma_{0R}}\right) = (r_R \sigma_{0R}) B - \sqrt{(r_R \sigma_{0R})^2 D^2 + A_0^2} \quad (a)$$

$$\left(\frac{M_0}{\sigma_{0L}}\right) = (r_L \sigma_{0L}) B - \sqrt{(r_L \sigma_{0L})^2 D^2 + A_0^2} \quad (b)$$

Eq. (8) is very similar to the expression for a single edge that appears just before Eq. (9) in Ref.11. It shows that for an edge where the wave function has a finite amplitude, the wall decay parameter tends to infinity with M_0 , while the products $r_L \sigma_{0L}$ or $r_R \sigma_{0R}$ are finite, corresponding to $B_{0L}, B_{0R} \rightarrow 0$ and $D_{0L}, D_{0R} \rightarrow 0$, as required. Using the results in Eq. (8), Eq. (6) can be solved for the vector, \bar{A} , yielding relations for the amplitudes:

$$\frac{A_2}{B_1} = \tanh \sigma L \frac{\hat{\sigma} D + \sqrt{\hat{\sigma}^2 D^2 + A_0^2}}{A_0} \quad (a)$$

$$\frac{A_1}{B_2} = -\tanh \sigma L \frac{\hat{\sigma} D - \sqrt{\hat{\sigma}^2 D^2 + A_0^2}}{A_0} \quad (9) \quad (b)$$

$$\frac{A_1}{B_1} = \frac{A_2}{B_2} = \gamma_{\hat{\sigma}} \tanh \sigma L \quad (c)$$

There are two solutions with either $\hat{\sigma} = r_R \sigma_{0R}$ and $\gamma_{\hat{\sigma}} = 1$ or $\hat{\sigma} = r_L \sigma_{0L}$ and $\gamma_{\hat{\sigma}} = -1$. Inspection of Eq. (3) shows that $\gamma_{\hat{\sigma}} = 1$ in Eq. (9)(c) corresponds to $\bar{\psi}_{\uparrow, \sigma}(-L) = 0$, and $\gamma_{\hat{\sigma}} = -1$, to $\bar{\psi}_{\uparrow, \sigma}(+L) = 0$. Hence Eq. (9) describes solutions with a finite amplitude on the right hand edge and zero amplitude on the left, or vice versa. The term, $\hat{\sigma}$, contains the wall decay parameter for the edge on which the wave function is localized. The value of $\hat{\sigma}$ is obtained by inserting Eq. (9)(c) into Eq. (5), yielding:

$$\hat{\sigma} = \sigma \left[\frac{1 + \tanh^2 \sigma L}{2 \tanh \sigma L} \right] \quad (10)$$

The decay parameter in the opposite wall is indeterminate, since the amplitude in that wall is zero.

The wave function in Eq. (3) can be written:

$$\begin{bmatrix} \psi_{1\uparrow} \\ \psi_{2\uparrow} \end{bmatrix} = B_2 \begin{bmatrix} \frac{A_1}{B_2} \left(\cosh \sigma y + \frac{1}{\left[\frac{A_1}{B_1} \right]} \sinh \sigma y \right) \\ \left(\frac{A_2}{B_2} \cosh \sigma y + \sinh \sigma y \right) \end{bmatrix} e^{ikx} \quad (11)$$

Substituting the expressions in Eq. (9) yields a pair of independent solutions for the two edges, which are combined linearly to form the general solution. This solution takes the form:

$$\begin{bmatrix} \Psi_{1\uparrow} \\ \Psi_{2\uparrow} \end{bmatrix} = C_1 \begin{bmatrix} Q_D (\tanh \sigma L \cdot \cosh \sigma y + C_2 \cdot \sinh \sigma y) \\ C_2 \tanh(\sigma L) \cdot \cosh \sigma y + \sinh \sigma y \end{bmatrix} e^{ikx} = \bar{\Psi}_{\uparrow, \sigma}(y) e^{ikx} \quad (12)$$

where

$$Q_D = \frac{\sqrt{\hat{\sigma}^2 D^2 + A_0^2} - \hat{\sigma} D}{A_0} \quad (13)$$

When the general solution is substituted back into the Hamiltonian in Eq. (1), the coefficient C_2 , is obtained:

$$C_2 = \frac{-Ak}{\left[M + B_+ \{k_x^2 - \sigma^2\} - E \right] Q_D + A\sigma \tanh \sigma L} \quad (14)$$

together with the characteristic equation:

$$F_C = \left[\sigma \tanh \sigma L + \frac{(M + B_- \{k_x^2 - \sigma^2\} + E)}{AQ_D} \right] + \left[\frac{\sigma}{\tanh \sigma L} + \frac{M + B_- \{k_x^2 - \sigma^2\} + E}{AQ_D} \right] - k^2 = 0 \quad (15)$$

Note that the characteristic equation is invariant to the transformation: $D \rightarrow -D$ and $E \rightarrow -E$. In the limit $L \rightarrow \infty$, Eq.(15) reverts to the result for a single edge, namely:

$$F_E = \left[\sigma + \frac{(M + B_- \{k_x^2 - \sigma^2\} + E)}{AQ_D} \right] \pm k = 0 \quad (16)$$

where the positive sign is for a left hand edge and the negative is for a right. This result agrees with Eq. (9) for a left hand edge in Ref.11.

For a symmetric band structure ($D = 0$) Eq. (15) can be rearranged to provide an analytical result for the edge state band gap by making the following substitutions:

$$M = -\frac{A\sigma}{2} \left[\frac{1}{\tanh \sigma L} + \tanh \sigma L \right] + B\sigma^2 - Bk_x^2 \quad (a)$$

$$\Delta E = A\sigma \left[\frac{1}{\tanh \sigma L} - \tanh \sigma L \right] = \frac{2A\sigma}{\sinh(2\sigma L)} \quad (b)$$

leading to a dispersion equation:

$$E = \sqrt{A^2 k_x^2 + \left(\frac{\Delta E}{2}\right)^2} \quad (18)$$

where ΔE is the edge state band gap. In the wide sample limit, when $L \rightarrow \infty$, Eq. (17)(a) yields decay parameters, $\sigma_{\pm} = \frac{A}{2B} \pm \sqrt{\frac{A^2}{4B^2} - \frac{|M|}{B} + k_x^2}$, in agreement with the result derived previously for a semi-infinite sample.¹¹

V. RESULTS AND DISCUSSION

Using the relations in Eqs. (12)–(15), some examples of edge state dispersions and wave functions are calculated in this section, for narrow samples based on HgTe/CdTe and InAs/GaSb/AlSb QWs. A number of different parameter sets are used to allow comparison with earlier works by the author and others. The different parameter sets are listed in Table I, together with references to the works from which they are taken. As mentioned above, $A_0 = A$, unless stated otherwise.

Figure 2 shows the dispersion of the spin up edge states in a HgTe/CdTe sample of width 100 nm, using Eq. (15) and parameter set (2). This set was derived in Ref. 11 by fitting the bulk band edge dispersion calculated from Eq. (1) to the equivalent dispersion determined with an 8 band $\mathbf{k} \cdot \mathbf{p}$ model. Since $D > B$, there is only one evanescent edge state solution, corresponding to σ_+ in Eq. (4). As discussed above, σ_- is imaginary and yields a spurious oscillatory solution. The edge state energies for decay parameter, σ_+ , and very large widths were calculated using Eq. (16) and presented in Fig. 2 (b) of Ref. 11. They obey dispersions which are essentially of the form: $Dk^2 - Ak$ for the left hand edge and $Dk^2 + Ak$ for the right (where $\sigma_+ \rightarrow 0$ at the merging points with the bulk band edges), and are shown in Figure 1 as dashed lines. The small width solutions tend to these values with increasing edge

state wave vector. At the zone center, however, an energy gap opens up of 2.9 meV. The dependence of the gap on sample width will be discussed below.

The edge state probability density, $|\Psi_{\uparrow}|^2 = |\Psi_{1\uparrow}|^2 + |\Psi_{2\uparrow}|^2$ is calculated from Eq. (12), and is plotted at specific wave vectors for positive energies above the edge state band gap in Figure 3 (a), and for negative energies below the edge state band gap in Figure 3 (b). At zero wave vector, the wave function has equal probabilities on both edges, and a very low probability in between. Although the probability densities look similar, the wave function parameter C_2 in Eq. (12) is zero for the upper band edge, and has an infinite limit as the wave vector approaches zero for the lower band edge. At finite wave vectors, however, the wave function becomes localized to one or the other edge, tending to the behavior of a wide sample. For example at a positive wave vector of $0.004 \times 2\pi/a$ it is localized to the right hand edge at positive energy and to the left hand edge at negative energy. When the wave vector is reversed, the sides also reverse ($a = 6.453 \text{ \AA}$ is the cubic lattice parameter of the substrate¹¹).

Figure 4(a) shows a plot of $|F_C|^2$ vs. positive energy at $k = 0$ and different HgTe/CdTe sample widths. The energy at which $|F_C|^2 = 0$ is the solution to the characteristic equation, Eq. (15), and in this case yields the energy of the positive edge of the edge state band gap demonstrated in Figure 2. It can be seen in Figure 4(a) that this energy solution is a continuous function of the sample width, so the edge state band gap decreases monotonically with increasing width. Quite different behavior is observed in Figure 4(b) for a weakly hybridized InAs/GaSb/AlSb QW, using parameter set (3) in Table I. At this stage the simpler case is considered of a symmetric band structure with $D = 0$. The asymmetric case with finite D will be discussed later on. The function, $|F_C|^2$ in Figure 4(b) is identical for each complex decay parameter, σ_{\pm} in Eq. (4), so when $|F_C|^2 = 0$ there are two degenerate solutions of the characteristic equation. Similar to HgTe/CdTe, a gap opens in the edge state spectrum at $k = 0$

when the sample is narrow. However, Figure 4 (b) shows that there are positive energy solutions, E_n , only at specific sample widths, in contrast to the monotonic dependence on width shown in Figure 4(a) for the strongly hybridized case. A band gap, $2E_n$, thus appears in the edge state dispersions at certain "characteristic widths" which are given in nanometers by the formula $L_S(n) = 35 + 24.5n$, where $n + 1$ is the characteristic width index. Figure 4(b) therefore corresponds to the 4th and 5th characteristic width values, close to 108.5 and 133 nm, respectively.

The reason for the existence of solutions only at certain characteristic widths of the weakly hybridized system can be understood by inspection of the wave functions. Figure 5 compares the probability densities at $k = 0$ for three adjacent characteristic widths of 84 nm, 108.6 nm and 133.2 nm. The solid lines are the physical solutions, $|\Psi_{\uparrow_C}|^2 = |\Psi_{1\uparrow_C}|^2 + |\Psi_{2\uparrow_C}|^2$, and the dashed lines are the spurious solutions, $|\Psi_{\uparrow_S}|^2 = |\Psi_{1\uparrow_S}|^2 + |\Psi_{2\uparrow_S}|^2$, based on linear combinations of the degenerate σ_+ and σ_- solutions, as described in Ref. 12. In the present case, this combination takes the form:

$$\overline{\Psi}_{\uparrow_{C,S}}(y)e^{ikx} = C_{\pm} \left\{ \overline{\Psi}_{\uparrow,\sigma_-}(y)e^{-i\frac{\theta}{2}} \pm \overline{\Psi}_{\uparrow,\sigma_+}(y)e^{i\frac{\theta}{2}} \right\} e^{ikx} \quad (19)$$

over the whole range of wave vectors, k , for which the decay parameters are complex, and where the positive sign is chosen for $\overline{\Psi}_{\uparrow_C}$, and the negative for $\overline{\Psi}_{\uparrow_S}$. Both solutions are real functions of y , so the probability current perpendicular to edge is zero. C_{\pm} is a normalization constant and the phase factor, θ , is adjusted to ensure orthogonality, noting that an increase or decrease by $\pi/2$ will switch $\overline{\Psi}_{\uparrow_C}$ to $\overline{\Psi}_{\uparrow_S}$ and vice versa.¹² It can be seen that the characteristic widths for $k = 0$ in Figure 5 are determined by the wave function oscillation period, with the probability density at the center of the sample changing from a node to an antinode between successive width values. For other sample widths, the

absence of a solution to the characteristic equation suggests that the edge states are no longer purely exponential.

The edge state bandgaps and characteristic widths can be reproduced quite well analytically, using Eq. (17). When $\sigma L > 1$, Eq. (17)(a) tends to the standard result for the decay parameters in very wide samples, given at the end of section IV. Thus, for strongly hybridized samples under these conditions, $\sigma(k_x = 0) = \frac{A}{2B} - \sqrt{\frac{A^2}{4B^2} - \frac{|M|}{B}}$ can be substituted into Eq. (17)(b), yielding values for the edge state band gap, ΔE , which agree to within 2% of those determined directly from the characteristic equation for $L_S \geq 100$ nm. In the case of weak hybridization, the decay parameters become complex¹¹, such that $\sigma(k_x = 0) = \mu \pm i\nu$, approximating to $\mu = \frac{A}{2B}$ and $\nu = \sqrt{\frac{|M|}{B} - \frac{A^2}{4B^2}}$ when $\text{Re}(\sigma L) > 1$. The condition: $\text{Im}(\Delta E) = 0$, yields a relation for the characteristic widths:

$$\tan(\nu L_S) = \frac{\nu}{\mu} \quad (20)$$

with solutions $L_S(n') = 9.9 + 24.7n'$ nm where $n' = 0, 1, 2, \dots, \infty$, calculated using parameter set (3) in Table I. The energy gaps at these characteristic widths are given by:

$$\Delta E = 8|M|e^{-\mu L_S} |\cos(\nu L_S)| \quad (21)$$

which agrees to within a few percent with those deduced directly from the characteristic equation for $L_S \geq 84$ nm. The first characteristic width of 9.9 nm calculated from Eq.(20) is very narrow, yielding an energy gap of 0.0156 eV from Eq. (21) which is larger than the bulk band gap of 0.0116 eV at

$k \approx 0.012 \times 2\pi/a$. Ignoring this width value, the next characteristic width is 34.6 nm. The analytical characteristic widths, $L_S(n')$, then agree quite well with the values, $L_S(n)$, deduced above by solving the characteristic equation directly.

The characteristic widths for weakly hybridized QWs also turn out to depend on the edge state wave vector. As shown previously by the author,¹² the period of oscillation of the edge state wave function increases with wave vector. An increasing period will cause the characteristic width to increase. Figure 6 shows the minimum value of $|F_C|^2$ as a function of wave vector for a constant sample width of 108.6 nm. $|F_C|^2$ oscillates and only satisfies the characteristic equation, $|F_C|^2 = 0$, at certain values of the wave vector. For other wave vectors, the characteristic equation appears to have no solution. Since there must be a solution that evolves smoothly with wave vector, the wave function must deform to accommodate the changing oscillation period, so that it is no longer purely exponential in character. Figure 6 (b) shows the probability density of the edge state wave functions based on Eq. (19) at wave vectors of $\pm 0.005775 \frac{2\pi}{a}$ and an energy of +0.002708 eV, corresponding to the first point away from the origin at which $|F_C|^2 = 0$ in Figure 6 (a). It can be seen that the state which propagates in the positive x -direction is localized to the right hand wall, while the state propagating in the opposite direction is localized to the left hand wall, similar to the behavior shown for HgTe/CdTe at positive energies in Figure 3 (a). As for HgTe/CdTe, the edge states with a given wave vector switch sides when the energy is negative.

Figure 7 summarizes the dependence of the edge state band gap on sample width for both strongly and weakly hybridized systems. The weakly hybridized system is plotted as equally spaced points, calculated at the characteristic widths where an exponential solution exists. The dashed line is simply an interpolation that has been assumed for the other sample widths with non-exponential

solutions. For the strongly hybridized system, results of calculations are shown using parameter set (1) in Table I, so that a comparison can be made between the present SBC treatment and the OBC treatment proposed by Zhou et al.¹³. It can be seen that the SBC band gap is about a factor of two smaller than the OBC band gap for a sample width of 200 nm, and that this factor grows larger as the sample width increases. SBC results are also shown for parameter set (2), which was used in an earlier work by the author, as mentioned above. The SBC results using this parameter set are quite close to those calculated using parameter set (1), demonstrating only a weak sensitivity to the precise parameter values, and in particular, to whether $D > B$ as in parameter set (2), or $D < B$, as in parameter set (1). It should also be noted that the edge state band gap in the strongly hybridized system is several orders of magnitude larger than that in the weakly hybridized system, for sample widths greater than 200 nm.

The results presented in Figure 7 are essentially independent of the hybridization parameter, A_0 , in the wall region. Eq. (13) shows that when D is zero, the function Q_D is one, and the characteristic equation in Eq. (15) becomes independent of A_0 . Thus the results in Figure 7 for the weakly hybridized case with $D = 0$ do not depend on the wall hybridization parameter at all. For the strongly hybridized case at $k = 0$, using parameter set (2) and $A_0 = A$ yields $Q_D = 0.95$, and the value of Q_D increases towards unity with increasing A_0 . Thus even in the strongly hybridized case with a large D -value, the band gap results in Figure 7 are virtually independent of the wall hybridization parameter. The function, Q_D also increases towards unity with k , so the dispersion results presented for HgTe/CdTe in Figure 2 exhibit negligible dependence on A_0 . When $A_0 = \hbar c \gg A$, corresponding to the hybridization parameter of a free particle, the mid gap energy shifts by only -0.00050 eV relative to that shown in Figure 2 for $A_0 = A$.

The solid and dashed curves in Figure 7 highlight the fact that when electron-hole hybridization is strong, exponentially decaying edge solutions satisfy SBCs for any non-zero value of the band

asymmetry parameter, D . However, when the electron-hole hybridization is weak this is not the case. Exponentially decaying edge solutions exist when $D = 0$ for wide samples, and for narrow samples with characteristic width values, but there are generally no purely exponential solutions over most of the wave vector range in weakly hybridized samples of any sample width when D is finite. Although the author reported edge state dispersion results for a semi-infinite InAs/GaSb/AlSb sample^{11,12} with D in the range 7-15 eV Å, these results turn out to be approximate, since they were based on finding the minimum in the value in $|F_E|^2$ in Eq. (16). Whilst this minimum is zero in the regions close to the bulk band edges where the edge state decay parameters are real, closer to the center of the Brillouin zone the decay parameters in Eq. (4) become complex and the minimum in $|F_E|^2$, although very small, no longer goes precisely to zero. This observation, overlooked in previous work, can be taken as an indication that the edge state wave functions in this wave vector range are not purely exponential.

It can be argued, that the energy at which $|F_E|^2$ is a minimum is still a good approximation for wide weakly hybridized samples, because it occurs at essentially the same value at which $|F_E|^2 = 0$ if a small imaginary component is added to the edge state wave vector. Clearly, the sample edge has translational symmetry in the direction of propagation, so a complex wave vector is not allowed. However, solutions of this sort should provide a good approximation to the exact solution in samples that are much shorter than the reciprocal of the imaginary wave vector component. It can easily be shown that this corresponds to sample lengths of at least several hundred Angstroms. Since the exact, non-exponential, solution must be independent of sample length, the short sample approximation must be close to the exact solution. In wide samples, the dispersions found for both spin directions using this approximation are not purely linear¹², and when $A_0 \approx A$, they have essentially the same k -dependence as for strongly hybridized systems with any value of $A_0 \geq A$, namely $Dk^2 \pm Ak$.

VI. CONCLUSION

In spite of its simplicity, the 4×4 $\mathbf{k} \cdot \mathbf{p}$ Hamiltonian in a basis of electron and heavy hole ground states has been very successful at identifying many of the bulk and edge phenomena in two dimensional topological insulators. However, while some of its solutions describe actual physical states, others exist in order to allow matching of boundary conditions at edges and interfaces and should not be interpreted as physically real. OBCs are attractive because they require zero amplitude at the sample boundaries and therefore avoid the need to define a Hamiltonian in the wall region beyond the boundaries. Unfortunately, edge states that satisfy OBCs incorporate both the real and spurious solutions, and while mathematically correct, they can exhibit unphysical characteristics. For this reason, it is impossible to avoid taking the wall region into account. Therefore, an approach has been followed where SBCs for the wave function and its derivative are obtained by integrating the Hamiltonian across the wall/semiconductor boundary. Exponentially decaying edge state solutions are found in the limit of an infinite wall potential, when the wave function decay parameter in the wall also becomes infinite, so the wave function is located entirely within the semiconductor. Based on this SBC approach, solutions were previously demonstrated for the physical spin-polarized edge states of a two dimensional topological insulator with a semi-infinite sample width, whose amplitude is large at the edge and decays with distance into the semiconductor. Since the boundary conditions exert an influence over the properties of the edge states, these properties are changed from those deduced using OBCs, for example introducing non-linearity into the edge state dispersions. In the present work, the SBC treatment has been extended to the case of samples with narrow widths, so that edge states from opposite boundaries interact and a band gap appears in the edge state energy spectrum. Some distinct differences have been found between materials with strong or weak electron-hole hybridization.

HgTe/CdTe is strongly hybridized and has physical, spin-polarized, exponentially decaying edge states with a real decay parameter and a non-linear energy dispersion that evolve smoothly with sample width and edge state wave vector. As the sample width is reduced, a gap opens at the zone center of the edge state dispersion, behavior qualitatively similar to that reported using OBCs. The band gap calculated with SBCs is about a factor of two smaller than the OBC band gap for a sample width of 200 nm, and this factor increases with sample width. The SBC band gap is relatively insensitive to the precise band structure parameters, including whether the band structure asymmetry is strong, $D > B$, or weak, $D < B$, and whether the electron-hole hybridization parameter in the wall is equal to or different from that in the sample. For strong band structure asymmetry there is no OBC solution, because the spurious solution switches from evanescent to oscillatory.

InAs/GaSb/AlSb is a weakly hybridized material. When the band structure asymmetry parameter is set to zero ($D = 0$), it was previously shown for very wide samples that there are degenerate, exponentially decaying, spin-polarized edge solutions with complex conjugate decay parameters over a specific range of positive and negative edge state wave vectors. The two complex conjugate solutions are combined into orthogonal physical and spurious solutions, where the physical solution evolves smoothly with wave vector over the region where the decay parameter becomes real, while the spurious solution does not. This picture changes dramatically as the sample width is reduced. A band gap opens in the edge state dispersions, but there are only exponential solutions for certain characteristic widths. Using typical band structure parameters, the characteristic width in nanometers was found to obey the relation, $35 + 24.5n$, where $n + 1$ is the width index. The equal separation of the characteristic widths is related to oscillations in the exponentially decaying edge state wave function for a single edge. The probability density at the center of the sample changes from a node to an antinode for successive characteristic width values. Although there are no purely exponential solutions at the zone center for other sample widths, the width dependence of the band gap can be deduced by

interpolation from its values at the characteristic widths. It is found to be several orders of magnitude smaller than for strongly hybridized HgTe/CdTe QWs when the sample width is greater than 200 nm. For finite band structure asymmetry ($D \neq 0$), there are no exponential edge state solutions for any sample width, except close to the merging points of the edge states with the bulk band edges. Nevertheless, since typical D -values are quite small, it is assumed that the bandgaps deduced for symmetric bands are still representative.

In summary, the SBC treatment with exponentially localized wave functions appears to provide an effective description of the spin polarized edge states in strongly hybridized QW samples of any width, even in the presence of strong band structure asymmetry. On the other hand, for weakly hybridized QWs, it only works at certain characteristic sample widths and edge state wave vectors, when there is no band structure asymmetry. In the presence of band structure asymmetry, purely exponential solutions do not exist over most of the wave vector range. The present work highlights the more complex nature of weakly hybridized systems.

ACKNOWLEDGEMENT: The author is indebted to Professor N. H. Linder in the Department of Physics, Technion, Haifa, 32000, Israel, for his helpful explanations and comments.

TABLE CAPTIONS

TABLE I. Parameters used in the calculations.

TABLE I.

<i>Parameter Set</i>	<i>A</i> (eVÅ)	<i>B</i> (eVÅ ²)	<i>D</i> (eVÅ ²)	<i>M</i> (eV)	<i>Ref.</i>
1	3.65	68.6	51.2	-0.010	[13]
2	3.86	50	70	-0.010	[11]
3	0.46	56	0	-0.010	[11]

FIGURE CAPTIONS

Figure 1. Band profiles in the growth direction for a 2D topological insulator QW based on (a) HgTe/CdTe or (b) InAs/GaSb/AlSb. Note the inverted ordering of the electron, E_1 , and heavy hole, HH_1 , ground states, characteristic of the topological phase.

Figure 2. The solid blue lines show the spin up edge dispersions for a HgTe/CdTe topological insulator QW with a sample width of 100 nm, calculated with parameter set (2). The bold black lines are the bulk dispersions. The dashed black lines show dispersions $D k^2 \pm A k$ which correspond to a very wide sample. The inset shows the zone center region on an expanded scale. a_{sub} is the cubic lattice parameter of the substrate (6.453Å).

Figure 3. Wave functions corresponding to edge state wave vectors, $k=0$, and $k = \pm 0.004 \times 2\pi/a$, for (a) positive and (b) negative energy dispersions in Fig. 2, where $a = a_{\text{sub}}$ is the cubic lattice parameter of the substrate (6.453Å). The edge on which the wave function is localized reverses, when either the sign of the wave vector or the energy is reversed.

Figure 4. Solution of the spin up characteristic equation, $|F_C|^2 = 0$ at $k = 0$ as a function of sample width between 108 nm and 134 nm, for (a) a HgTe/CdTe QW, where the curves correspond to the non-spurious σ_+ solution in Eq. (4) and parameter set (2), and (b) an InAs/GaSb/AlSb QW where the curves are degenerate in σ_+ and σ_- , and parameter set (3) is used with $D = 0$. In (b) solutions only exist at certain characteristic widths of 108.6 nm and 133.2 nm.

Figure 5. Probability densities for the spin up physical, $|\Psi_{\uparrow C}|^2$, and spurious, $|\Psi_{\uparrow S}|^2$, edge states at $k = 0$ (solid and dashed lines, respectively), at characteristic widths of 84 nm, 108.6 nm and 133.2 nm (spin-down results are identical).

Figure 6. (a) Minimum value of $|F_C(\sigma_{\pm})|^2$ vs. edge state wave vector for a InAs/GaSb/AlSb QW of sample width 108.6 nm, using $A_0 = A$ and parameter set (3) where $D = 0$. Solutions of the characteristic equation, $|F_C(\sigma_{\pm})|^2 = 0$, only exist at certain values of the wave vector. The curve applies to both values of the decay parameter, σ_{\pm} , for which the solutions are degenerate, and does not depend on the signs of the wave vector or energy, or on the value of A_0 (b) Probability densities for the spin up physical edge states, $|\Psi_{\uparrow C}|^2$, at $k = \pm 0.005775 \times 2\pi / a$ and $E = 0.002708$ eV, corresponding to the shortest finite wave vectors for which $|F_C(\sigma_{\pm})|^2 = 0$ in (a). The cubic lattice parameter of the substrate is $a = a_{\text{sub}} (6.0954 \text{ \AA})$.

Figure 7. Dependence of the edge state band gap on sample width calculated with SBCs using parameter sets (1), (2) and (3). The results for parameter set (1) are compared with the OBC solution, reported for the same parameter values in Ref. 13.

FIGURE 1

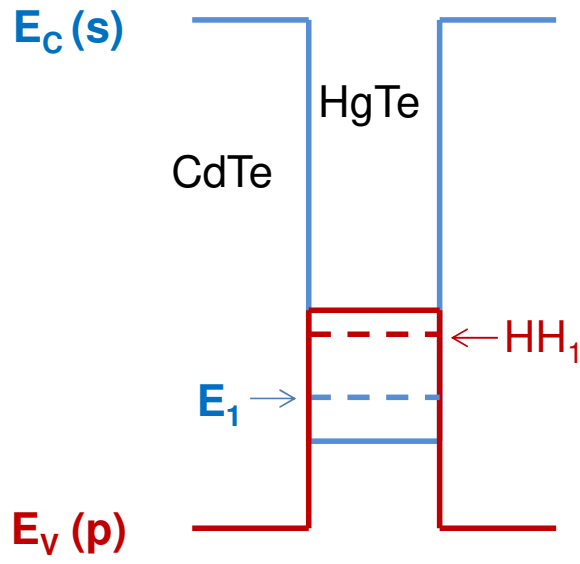

(a)

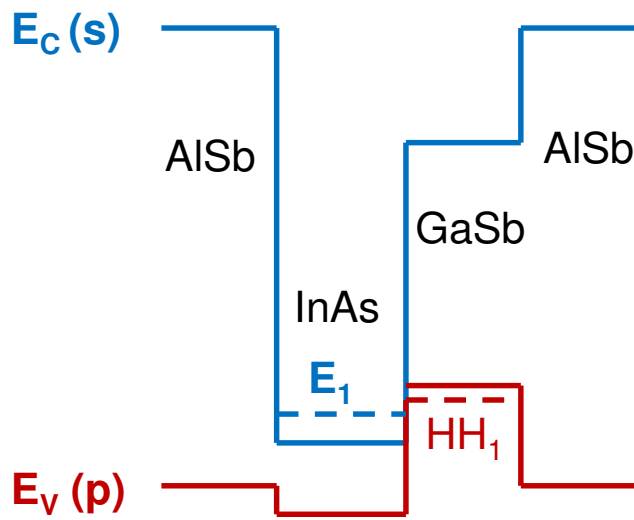

(b)

FIGURE 2

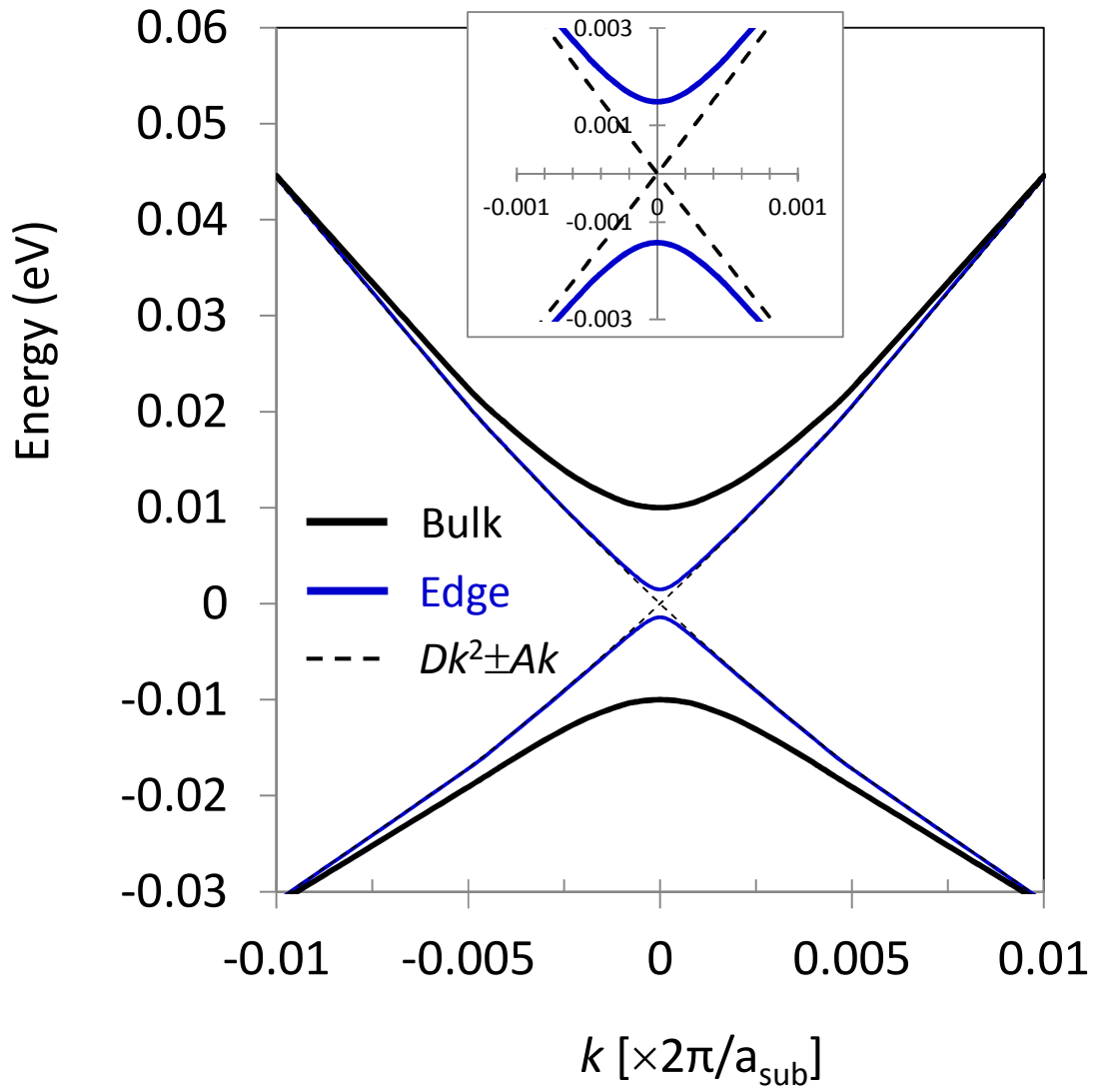
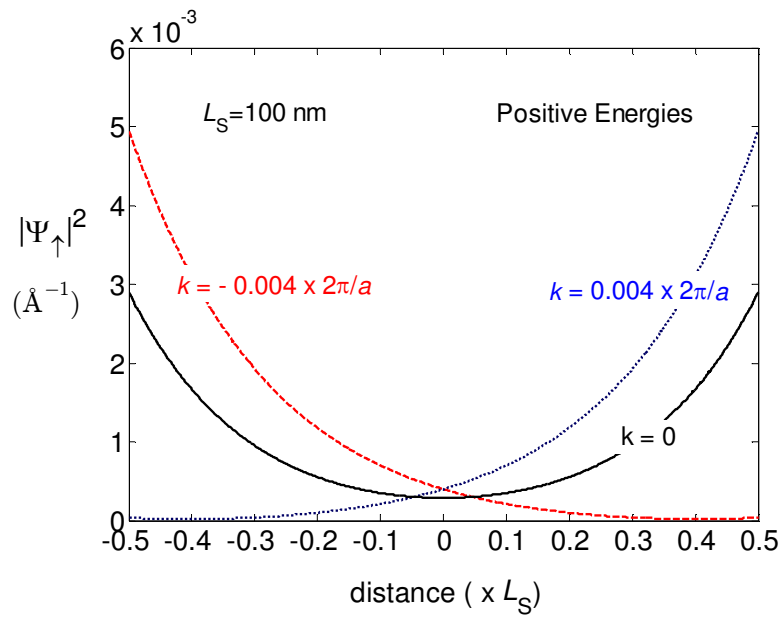
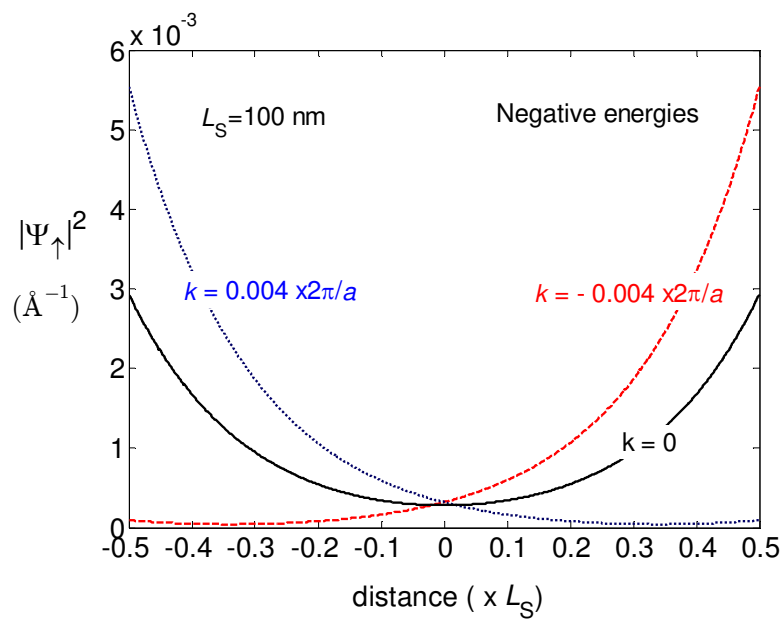

FIGURE 3



(a)



(b)

FIGURE 4

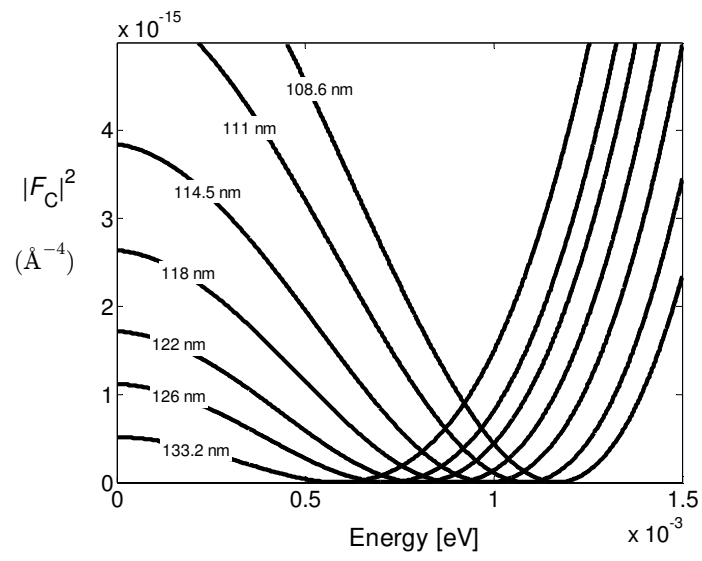

(a)

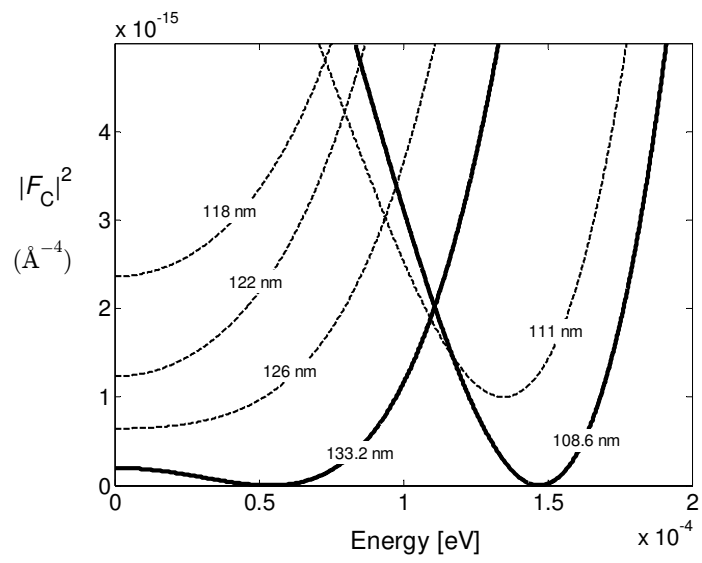

(b)

FIGURE 5

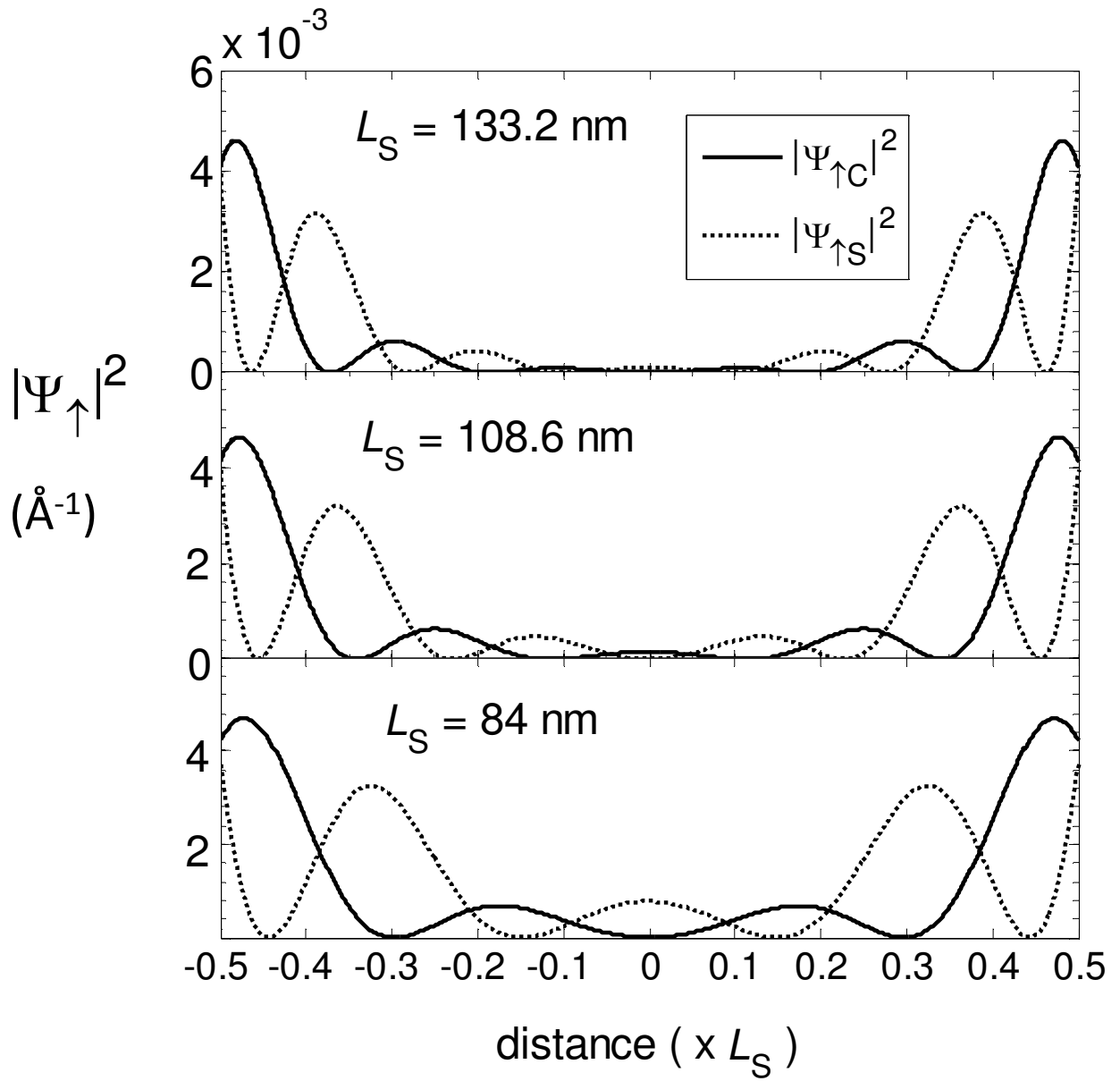
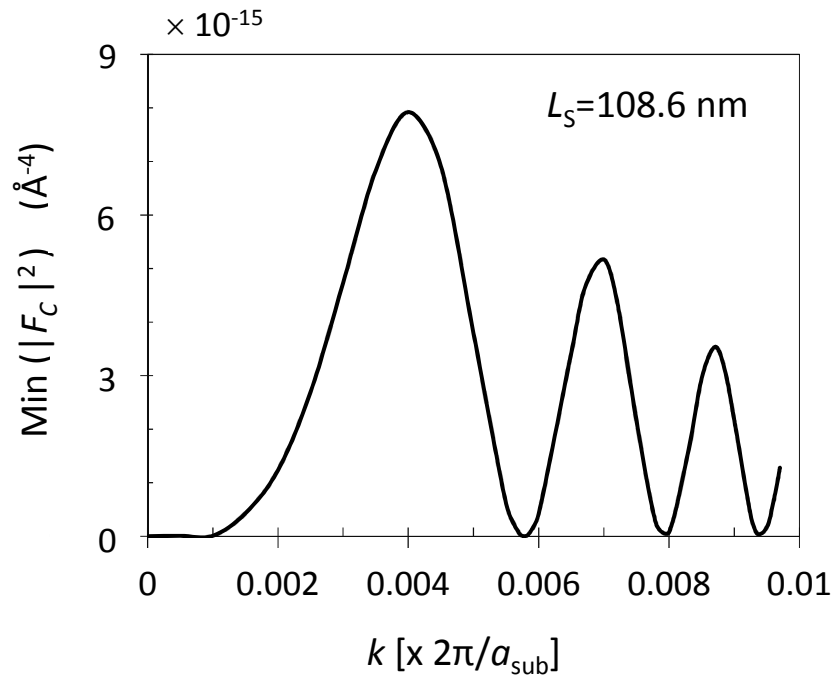
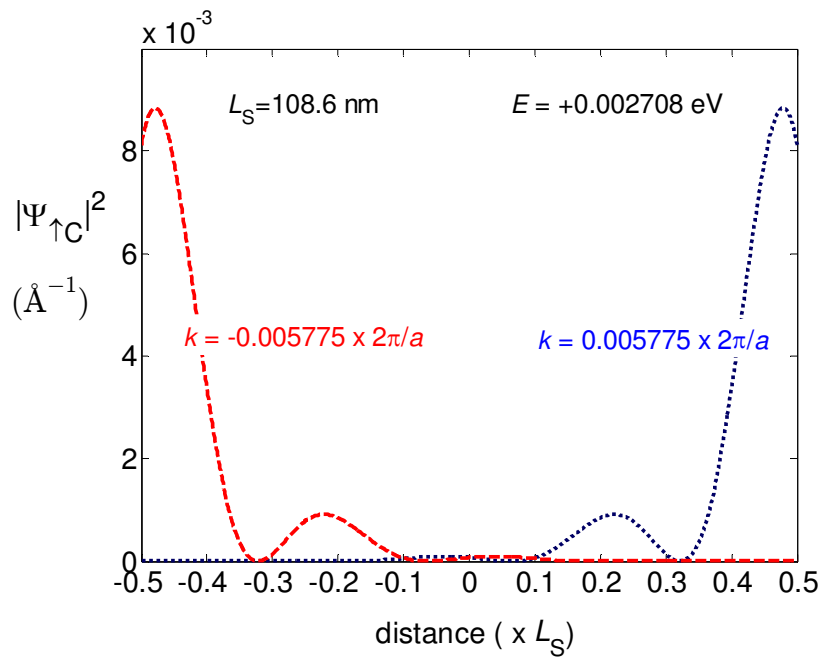

FIGURE 6



(a)



(b)

FIGURE 7

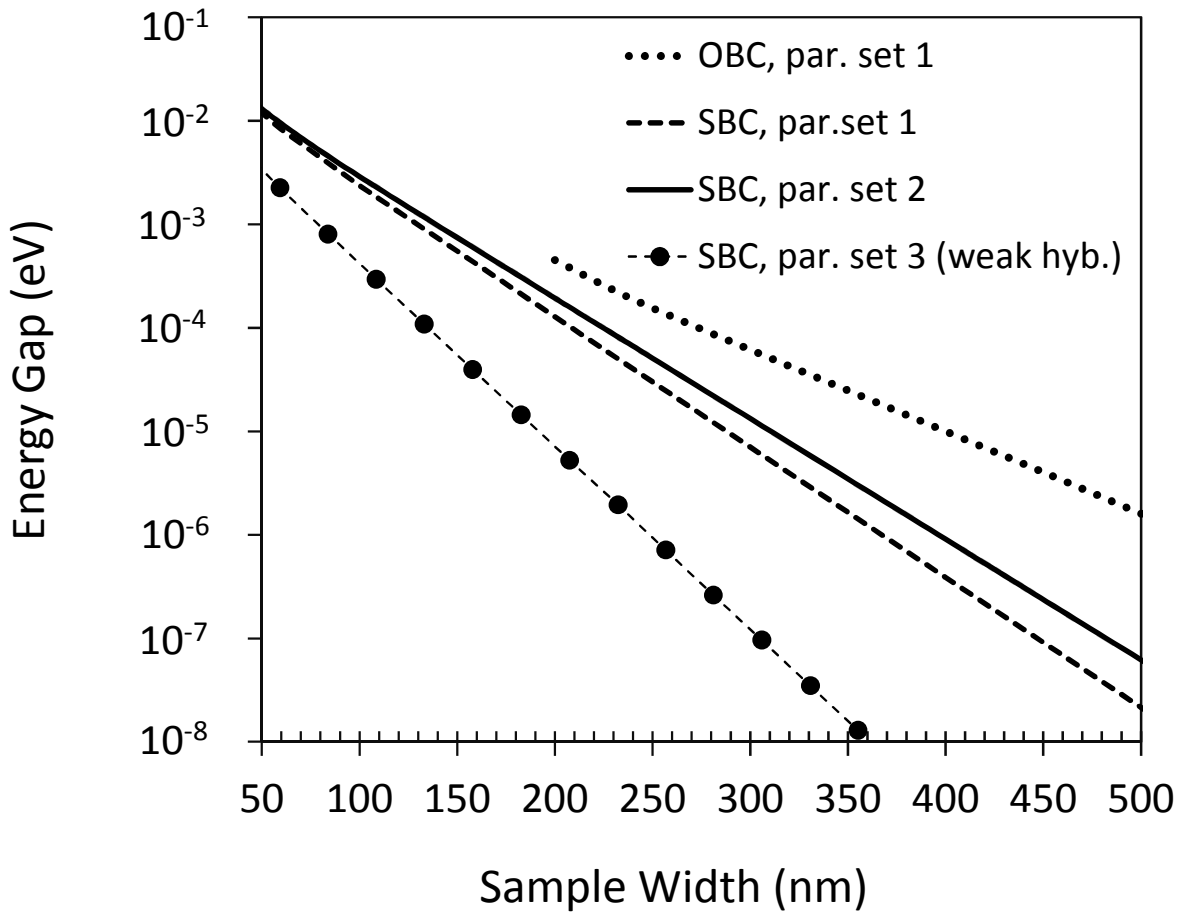

REFERENCES

-
- [1] X-L Qi and S-C Zhang, *Physics Today*, **63**, 33 (2010)
- [2] B.A. Bernevig, T.L. Hughes and S-C Zhang, *Science* **314**, 1757 (2006)
- [3] C. Liu, T.L. Hughes, X-L Qi, K. Wang and S-C Zhang, *Phys. Rev. Lett.* **100**, 236601 (2008)
- [4] M. König, H. Buhmann, L. W. Molenkamp, T.L. Hughes, C-X Liu, X-L. Qi, S-C. Zhang, *J. Phys. Soc. Jpn.* **77**, 031007 (2008)
- [5] I. Knez, R-R Du and G. Sullivan, *Phys. Rev. Lett.* **107**, 136603 (2011)
- [6] P. Ballet, C. Thomas, X. Baudry, C. Bouvier, O. Crauste, T. Meunier, G. Badano, M. Veillerot, J.P. Barnes, P.H. Jouneau and L. P. Levy, *Journal of Elec. Materials*, **43**, 2955 (2014)
- [7] P.C. Klipstein, E. Avnon, Y. Benny, E. Berkowicz, Y. Chaham, O. Cohen, Y. Cohen, R. Dobromislin, R. Fraenkel, G. Gershon, A. Glozman, E. Hojman, E. Ilan, Y. Karni, O. Klin, Y. Kodriano, L. Krasovitsky, L. Langof, I. Lukomsky, I. Nevo, M. Nitzani, I. Pivnik, N. Rappaport, O. Rosenberg, N. Shiloah, I. Shtrichman, L. Shkedy, N. Snapi, R. Talmor, R. Tessler, E. Weiss and A. Tuito, *Journal of Elec. Materials* **46**, 5386 (2017).
- [8] A.N. Baranov and N. Teissier, *IEEE Journ. of selected topics in quantum electronics*, **21**, 1200612 (2015)
- [9] L. Du, I. Knez, G. Sullivan, RR. Du, *Phys. Rev. Lett.* **114**, 096802 (2015)
- [10] I. Knez, C. T. Rettner, S.-H Yang, S. S. P. Parkin, L. Du, R-R Du, and G. Sullivan. *Phys. Rev. Lett.* **112**, 026602 (2014)
- [11] P.C. Klipstein, *Phys. Rev. B* **91**, 035310 (2015); Erratum, *Phys. Rev. B* **93**, 199905(E) (2016)
- [12] P.C. Klipstein, *J. Phys: Condens. Matter* **28**, 375801 (2016)
- [13] B. Zhou, H-Z Li, R-L Chu, S-Q-Shen and Q. Niu, *Phys. Rev. Lett.* **101**, 246807 (2008)
- [14] P.C. Klipstein (2016), stacks.iop.org/JPhysCM/28/375801/mmedia
- [15] E. E. Takhtamirov and V. A. Volkov, *Semicond. Sci. Technol.* **12**, 77 (1997).
- [16] P. C. Klipstein, *Phys. Rev. B* **81**, 235314 (2010)
- [17] S.R. White and L. J. Sham, *Phys. Rev. Lett.* **47**, 879 (1981)
- [18] M.F.H Schuurmans and G. W. t'Hooft, *Phys. Rev. B.* **31**, 8041 (1985)
- [19] G. Tkachov and E. M. Hankiewicz, *Phys. Status Solidi B* **250**, 215 (2013)
- [20] E.B. Sonin, *Phys. Rev. B* **82**, 113307 (2010)
- [21] S.A. Tarasenko, M.V. Durnev, M.O. Nestoklon, E.L. Ivchenko, Jun-Wei Luo, and Alex Zunger, *Phys. Rev. B* **91**, 081302 (R) (2015)
- [22] S.Q. Shen, W.Y. Shan, and H.Z. Lu, *Spin* **1**, 33 (2011).
- [23] M. Wada, S. Murakami, F. Freimuth and G. Bihlmayer, *Phys. Rev. B* **83**, 121310 (R) (2011)