

ARITHMETIC, GEOMETRY AND DYNAMICS IN THE UNIT TANGENT BUNDLE OF THE MODULAR ORBIFOLD

ALBERTO VERJOVSKY

INSTITUTO DE MATEMÁTICAS, UNIDAD CUERNAVACA
UNIVERSIDAD NACIONAL AUTÓNOMA DE MÉXICO

Updated version of the paper of the same title that appeared in: Verjovsky, A. *Arithmetic geometry and dynamics in the unit tangent bundle of the modular orbifold*. Dynamical systems (Santiago, 1990), 263–298, Pitman Res. Notes Math. Ser., 285, Longman Sci. Tech., Harlow, 1993.

INTRODUCTION

The modular group $\mathrm{PSL}(2, \mathbb{Z})$ and its action on the upper half-plane \mathbb{H} together with its quotient, the modular orbifold, are fascinating mathematical objects. The study of modular forms has been one of the classical and fruitful objects of study. If one considers the group $\mathrm{PSL}(2, \mathbb{R})$ and we take the quotient $M = \mathrm{PSL}(2, \mathbb{R})/\mathrm{PSL}(2, \mathbb{Z})$ one obtains a three dimensional manifold that carries an enormous amount of arithmetic information. Of course this is not surprising as the elements of $\mathrm{PSL}(2, \mathbb{Z})$ are Möbius transformations given by matrices with columns consisting of lattice points with relatively prime integer coefficients and therefore M contains information about the prime numbers. On the other hand from the dynamical systems viewpoint, M is also very interesting—it has a flow which is an Anosov flow. The flow as well as its stable and unstable foliations correspond to three one-parameter subgroups: the geodesic flow, and the stable and unstable horocycle flows (see the next section). All these flows preserve normalized Haar measure \bar{m} , and are ergodic with respect to this measure. By a theorem of Dani [4] the horocycle flows have a curve $D(y)$, ($y > 0$), of ergodic probability measures. These ergodic measures are supported in closed orbits of period y^{-1} of the corresponding horocycle flows. If we denote by m_y the measure corresponding to $y > 0$, then m_y converges to \bar{m} as $y \rightarrow 0$ ([4] [19]). We will also give a proof of this. However what is most interesting for me as a person working on a dynamical systems is the remarkable connection found by Don Zagier between the rate of approach of m_y to \bar{m} and the Riemann Hypothesis. Zagier found that the Riemann Hypothesis holds if and only if for every smooth function f with compact support on M one has $m_y(f) = \bar{m}(f) + o(y^{3/4-\epsilon})$ for all $\epsilon > 0$. We also proved that $m_y(f) = \bar{m}(f) + o(y^{1/2})$. In the Appendix we will review Zagier's approach as well as the extension given by Sarnak [16].

The purpose of this paper is to analyze the dynamics and geometry of the horocycle flow to show that the exponent $1/2$ is optimal for certain characteristic functions of sets called “boxes”. Of course this is very far from disproving the Riemann Hypothesis since a characteristic function is not even continuous.

Our result puts in evidence the fact that the Riemann hypothesis is also a regularity problem. At the end it is the lack of the Riemann-Lebesgue lemma for functions that are not in L_1 . We remark that in Zagier paper [19] this point is not clarified.

By geometric means we reduce the analysis of the convergence of m_y to \overline{m} to a lattice point counting. Thus the fact that the exponent cannot be made better than $1/2$ is similar to the circle problem in which we count the number of lattice points with relatively prime coordinates inside a circle. If instead we take a smooth function f with compact support and take the sum $\Sigma(y)$, of the values of the function over all lattice points (yn, ym) with $y > 0$ and $(n, m) \in \mathbb{Z}^2$ then $y^2 \Sigma(y)$ will converge to the integral of f over the plane as $y \rightarrow 0$ and the error term will be $o(y^\alpha)$, as $y \rightarrow 0$, for all $\alpha > 0$. This follows by the Poisson summation formula using the fact that the Fourier transform of f decays very rapidly at infinity.

We will use many properties of $\mathrm{SL}(2, \mathbb{R})$, its quotients by discrete subgroups and the two locally free actions of the proper real affine group on these quotients. Good references for each subject are [1], [8], [11], [13] and [15].

0. PRELIMINARES

Let $\tilde{G} := \mathrm{SL}(2, \mathbb{R})$ denote the Lie group of 2×2 matrices of determinant one, with real coefficients. The Lie algebra of \tilde{G} , $\mathfrak{g} := \mathfrak{sl}(2, \mathbb{R})$, consists of real 2×2 matrices of trace zero. This Lie algebra has the standard basis:

$$A = \begin{bmatrix} 1/2 & 0 \\ 0 & -1/2 \end{bmatrix}, \quad B = \begin{bmatrix} 0 & 1 \\ 0 & 0 \end{bmatrix}, \quad C = \begin{bmatrix} 0 & 0 \\ 1 & 0 \end{bmatrix}.$$

To A , B and C correspond the left-invariant vector fields X , Y , and Z respectively in $\mathrm{SL}(2, \mathbb{R})$. These vector fields induce, respectively, the nonsingular flows:

$$g_t : \tilde{G} \rightarrow \tilde{G}, \quad h_t^+ : \tilde{G} \rightarrow \tilde{G}, \quad h_t^- : \tilde{G} \rightarrow \tilde{G}, \quad t \in \mathbb{R}.$$

Explicitly:

$$(0.1) \quad \begin{aligned} g_t \left(\begin{bmatrix} a & b \\ c & d \end{bmatrix} \right) &= \begin{bmatrix} a & b \\ c & d \end{bmatrix} \begin{bmatrix} e^t & 0 \\ 0 & e^{-t} \end{bmatrix}, \\ h_t^+ \left(\begin{bmatrix} a & b \\ c & d \end{bmatrix} \right) &= \begin{bmatrix} a & b \\ c & d \end{bmatrix} \begin{bmatrix} 1 & t \\ 0 & 1 \end{bmatrix}, \\ h_t^- \left(\begin{bmatrix} a & b \\ c & d \end{bmatrix} \right) &= \begin{bmatrix} a & b \\ c & d \end{bmatrix} \begin{bmatrix} 1 & 0 \\ t & 1 \end{bmatrix}, \quad t \in \mathbb{R}. \end{aligned}$$

To simplify notation, let us write: $g := \{g_t\}_{t \in \mathbb{R}}$, $h^+ := \{h_t^+\}_{t \in \mathbb{R}}$, and $h^- := \{h_t^-\}_{t \in \mathbb{R}}$.

Consider the upper half-plane, $\mathbb{H} = \{z = (x, y) := x + iz \mid y > 0\} \subset \mathbb{C}$ equipped with the metric $ds^2 = (1/y^2)(dx^2 + dy^2)$. With this metric \mathbb{H} is the hyperbolic plane with constant negative curvature minus one.

\tilde{G} acts by isometries on \mathbb{H} as follows:

$$\begin{bmatrix} a & b \\ c & d \end{bmatrix} \begin{bmatrix} x \\ y \end{bmatrix} = \frac{az + b}{cz + d}$$

where $z = x + iy$, $y > 0$.

The action is not effective and the kernel is the subgroup of order two $\{I, -I\}$, consisting of the identity and its negative.

Let $G = \tilde{G}/\{I, -I\} := \text{PSL}(2, \mathbb{R})$. Note that G is the group of Möbius transformations that preserve \mathbb{H} and is in fact its full group of orientation-preserving isometries.

The action of G on \mathbb{H} can be extended via the differential to the unit tangent bundle which we shall denote henceforth by $T_1\mathbb{H}$. If $\gamma \in G$ and γ' denotes its differential acting on unit vectors, we have:

$$\begin{array}{ccc} T_1\mathbb{H} & \xrightarrow{\gamma'} & T_1\mathbb{H} \\ P_1 \downarrow & & \downarrow P_1 \\ \mathbb{H} & \xrightarrow{\gamma} & \mathbb{H} \end{array}$$

where P_1 is the canonical projection. Naturally, “unit vector” refers to the hyperbolic metric.

By euclidean translation to the origin and clockwise rotation of 90 degrees we have a trivialization $\psi : T_1\mathbb{H} \rightarrow \mathbb{H} \times S^1$ given by

$$(0.2) \quad \psi(z, v) = (z, -iv/|v|), \quad (i^2 = -1),$$

where v is a hyperbolic unit tangent vector anchored at $z \in T_1\mathbb{H}$. For example, using (0.2), $\gamma \mapsto \gamma'(i, 1)$ gives an explicit identification and it will be the one we will use here.

If $\gamma = \begin{bmatrix} a & b \\ c & d \end{bmatrix} \in \tilde{G}$, we will let $\bar{\gamma}(z) = \frac{az+b}{cz+d}$ denote the corresponding element in G .

Using trivialization (0.2), we have

$$(0.3) \quad \gamma'(z, \theta) = (\bar{\gamma}(z), \theta - 2 \arg(cz + d)).$$

In this notation θ is to be taken modulo 2π , where the angle of a unit vector is *measured from the vertical counter-clockwise*.

The three basic vector fields X , Y and Z descend to $G \simeq T_1\mathbb{H}$ and the flows induced by them correspond to the *geodesic flow*, *unstable horocycle flow* and *stable horocycle flow*, respectively.

Geometrically these flows can be described as follows. Let $z \in \mathbb{H}$ and let $v_z \in T_1\mathbb{H}$ be a unit vector based at z . This vector determines a unique oriented geodesic γ , as well as two oriented horocycles C^+ and C^- which pass through z are orthogonal to γ and tangent to the real axis. Then $v' := g_t(v_z)$ is the unit vector tangent to γ , following the same orientation as γ at the point at distance t from z . The vectors $w^+ = h_u^+(v_z)$ and

$w^- = h_v(v_z)$ are obtained by taking unit vectors tangent to C^+ and C^- , respectively, at distances u and v respectively, and according to their orientations (see Figure 1).

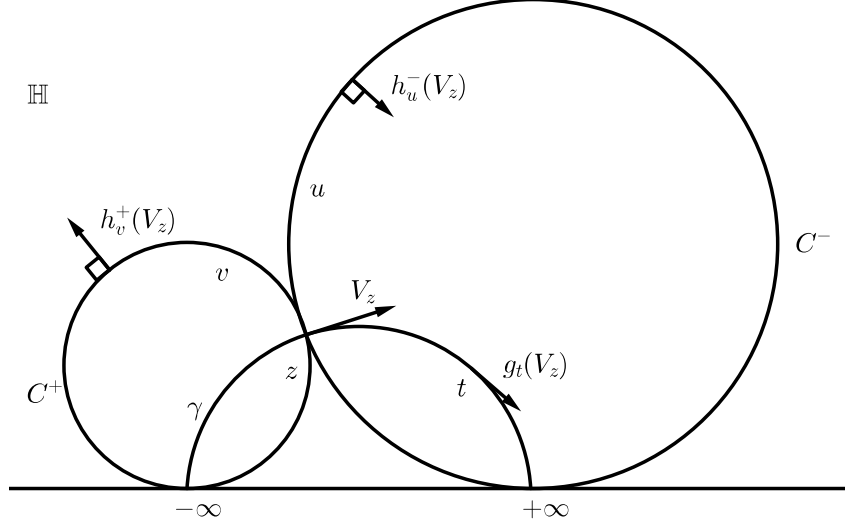

FIGURE 1

It is because of this geometric interpretation that the flows g , h^+ and h^- , defined originally in \tilde{G} are called *geodesic* and *horocycle* flows respectively. Formulae (0.1) tell us that the orbits of the respective flows are obtained by left-translations of the one-parameter subgroups

$$t \mapsto \begin{bmatrix} e^{t/2} & 0 \\ 0 & e^{-t/2} \end{bmatrix}, \quad u \mapsto \begin{bmatrix} 1 & u \\ 0 & 1 \end{bmatrix}, \quad v \mapsto \begin{bmatrix} 1 & 0 \\ v & 1 \end{bmatrix}.$$

Every noncompact one-parameter subgroup is conjugate in \tilde{G} to one of the above, and h^+ is conjugate to h^- .

Henceforth we will equip \tilde{G} with the left-invariant Riemannian metric such that $\{X, Y, Z\}$ is an oriented orthonormal framing. We will call this metric the *standard metric*.

By the *standard Riemannian measure* or *Haar Measure*, we will mean the measure, m , induced by the volume form Ω which takes the constant value one in the oriented framing $\{X, Y, Z\}$. Since \tilde{G} is unimodular, the measure m is bi-invariant.

Let $A_2(\mathbb{R})$ denote the *proper affine group*:

$$A_2(\mathbb{R}) = \{T : \mathbb{R} \rightarrow \mathbb{R} \mid T(r) = ar + b; a, b \in \mathbb{R}, a > 0\}.$$

Let us parametrize $A_2(\mathbb{R})$ by pairs (a, b) with $a, b \in \mathbb{R}$, $a > 0$.

There are two monomorphisms, $A_2(\mathbb{R}) \hookrightarrow \tilde{G}$, given by:

$$(0.4) \quad (a, b) \mapsto \begin{bmatrix} a & b \\ 0 & a^{-1} \end{bmatrix}, \quad (a, b) \mapsto \begin{bmatrix} a & 0 \\ b & a^{-1} \end{bmatrix}.$$

We see from these inclusions that the pairs $\{X, Y\}$ and $\{X, Z\}$ generate Lie algebras isomorphic to the Lie algebra of the affine group:

$$[X, Y] = Y, \quad [X, Z] = -Z, \quad [Y, Z] = X.$$

As a consequence, \tilde{G} contains two real analytic foliations by planes whose leaves are the orbits of the free actions of the affine group in \tilde{G} (or simply, the leaves are obtained by left-translations of the two copies of the affine group). These two foliations, denote respectively by \mathcal{F}^+ and \mathcal{F}^- , intersect transversely along the orbits of the geodesic flow. The geodesic flow is an Anosov flow and \mathcal{F}^+ and \mathcal{F}^- are its *unstable* and *stable* foliations.

Each leaf of \mathcal{F}^+ and \mathcal{F}^- inherits from the standard metric, a metric of constant negative curvature equal to minus one. The geodesic flow permutes the orbits of h^+ as well as the orbits of h^- . It dilates uniformly and exponentially the orbits of h^+ and contracts uniformly and exponentially the orbits of h^- .

The flows h^+ and h^- in the unit tangent bundle of \mathbb{H} are conjugate by the so-called “flip map” which sends a unit tangent vector to its negative. *therefore, any dynamical or ergodic property that holds for h^+ also holds for h^- .*

For any discrete subgroup $\Gamma \subset G$, the basic vector fields X, Y and Z descend to the quotient

$$M(\Gamma) := \mathrm{PSL}(2, \mathbb{R})/\Gamma,$$

and they induce flows which we will still denote by g, h^+ and h^- .

The standard metric, invariant form Ω and Haar measure m descend to $M(\Gamma)$. All three flows g, h^+ and h^- defined in $M(\Gamma)$ preserve m . Therefore g is a volume-preserving Anosov flow.

When Γ is a discrete, co-compact subgroup, then g, h^+ and h^- are all m -ergodic and g is a topologically transitive Anosov flow. In this case $M(\Gamma)$ is a Seifert bundle over a compact two dimensional orbifold. The exceptional fibres are due to the elliptic elements of Γ . Both foliations \mathcal{F}^+ and \mathcal{F}^- are transverse to the fibres and every leaf is dense.

When Γ is co-compact both h^+ and h^- are minimal flows on $M(\Gamma)$. In particular, the horocycle flows do not contain periodic orbits. This was proved by Hedlund [9]. It is also a consequence of a result of Plante [14]. Suppose for instance that one orbit of h^+ is not dense. Then the closure of this orbit contains a non-trivial minimal set Σ and Plante showed that Σ must be both a 2-torus and a global cross section for the geodesic flow, implying that $M(\Gamma)$ would be a torus bundle over S^1 . But this is impossible since under the hypothesis, Γ cannot be solvable.

It was shown by Furstenberg [7] that for Γ co-compact both h^+ and h^- are strictly ergodic flows with m as their unique invariant measure (this also implies minimality of h^+ and h^-). Since the geodesic flow is transitive, it contains a set of the second Baire category of dense orbits and it also contains a countable number of periodic orbits whose union is dense in $M(\Gamma)$. The number of such periodic orbits as a function of their periods grows exponentially. Margulis has a formula relating the topological entropy of g and the rate of growth of periodic orbits. This formula was also later obtained by Bowen. These facts

are interesting because the horocycle flow is the limit of conjugates of the geodesic flow as can easily be seen by considering the vector fields $X_\epsilon = \epsilon X + Y$ as ϵ tends to zero.

When Γ is a nonuniform lattice (i.e. when Γ is discrete, $M(\Gamma)$ is not compact, and $m(M(\Gamma)) < \infty$) the g , h^+ and h^- are still m -ergodic. However, for nonuniform lattices both h^+ and h^- are not minimal.

If $\Gamma \subset G$ is any discrete subgroup, then $\Gamma \backslash \mathbb{H} := S(\Gamma)$ is a complete hyperbolic orbifold. If Γ is co-compact this means that $S(\Gamma)$ is a compact surface provided with a special metric and a finite number of distinguished points or *conical points* labelled by rational integers. The complement of the conical points is isometric a surface of curvature minus one (in general incomplete), and of finite area. Each distinguished point has a neighborhood which is isometric to the metric space obtained by identifying, isometrically, the two equal sides of an isosceles hyperbolic triangle. These two equal sides have to meet at an angle $2\pi p/q$, where p/q is the rational number attached to the distinguished point. Of course, the distinguished points correspond to the equivalence of fixes points of elliptic elements of Γ . $S(\Gamma)$ is obtained by identifying sides of a fundamental domain which is a finite hyperbolic polygon in \mathbb{H} by elements of Γ .

A classical theorem of Selberg (which also holds for $\mathrm{PSL}(2, \mathbb{C})$) asserts that Γ contains a subgroup $\tilde{\Gamma}$ of finite index and without elliptic elements. Then $S(\tilde{\Gamma})$ is a branched covering of $S(\Gamma)$ and it is a complete hyperbolic surface without conical points and finite area. In the unit tangent bundle $T_1(S(\tilde{\Gamma})) = G/\tilde{\Gamma}$ we have the geodesic and horocycle flows and there is a finite covering map from $T_1(S(\tilde{\Gamma}))$ onto $G/\Gamma = M(\Gamma)$ whose deck transformations commute with the three flows. In this way, for any discrete Γ , we can now speak of the horocycle and geodesic flows on an orbifold. $M(\Gamma)$ plays the role of the unit tangent bundle of $S(\Gamma)$ when Γ has elliptic elements.

If Γ is a nonuniform lattice then $S(\Gamma)$ is a noncompact, complete, hyperbolic orbifold of finite area. The orbifold is obtained by identifying isometrically, pairs of sides of an *ideal* hyperbolic polygon of finite area. It then follows that the fundamental polygon has a finite number of sides and there must be at least one vertex at infinity. Each vertex at infinity is the common end point of two asymptotic geodesics which are identified by a parabolic element of Γ (see Figure 2).

In this way we obtain a “cusp” for each equivalence class under Γ of the set of vertices at infinity. Also we obtain a one-parameter family of closed horocycles in $S(\Gamma)$.

The orbifold $S(\Gamma)$ has a finite number of cusps and conical points. If we compactify $S(\Gamma)$ by adding one point at infinity for each cusp we obtain a compact surface $S(\Gamma)$. It is natural to label these new points by the symbol ∞ (or by ∞_c if we want to specify the cusp c) even though the “angle” at a cusp is zero.

The genus, area, number of cusps and conical points are related by a Gauss-Bonnet type of formula.

In this paper the most important orbifold will be the *modular orbifold* which correspond to $\Gamma = \mathrm{PSL}(2, \mathbb{Z})$. Its area is, by Gauss-Bonnet formula, equal to $\pi/3$. An important number for us will be $\pi^2/3$ which is the volume of $\mathrm{PSL}(2, \mathbb{R})/\mathrm{PSL}(2, \mathbb{Z})$.

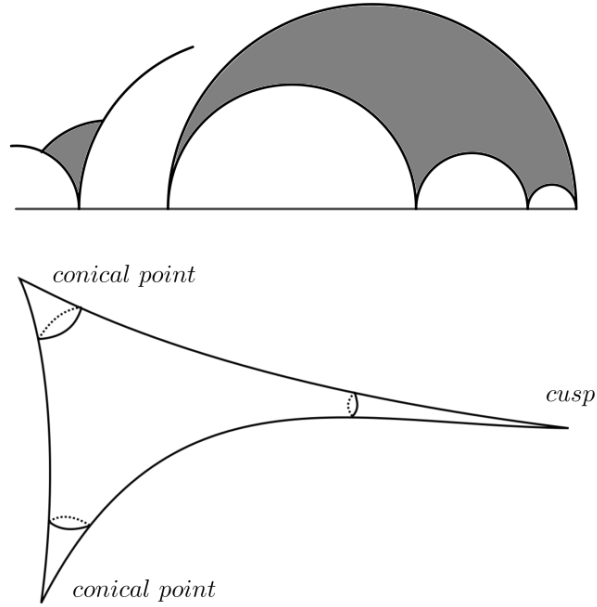

FIGURE 2

Notation. $M := M(\mathrm{SL}(2, \mathbb{Z})) = \mathrm{PSL}(2, \mathbb{R})/\mathrm{PSL}(2, \mathbb{Z})$.

The modular orbifold is obtained from the standard modular fundamental domain by identifying sides as shown in figure 3.

The modular orbifold has just one cusp and two conical points with labels $\frac{1}{2}$ and $\frac{1}{3}$. M is a Seifert bundle over the modular orbifold with two exceptional orbits corresponding to the conical points. Both foliations \mathcal{F}^+ and \mathcal{F}^- have dense leaves. Let $\Gamma \subset G$ be any nonuniform lattice. Assume for simplicity that Γ does not have elliptic elements. Consider all asymptotic geodesics corresponding to a given cusp. The union of all these geodesic covers the orbifold $S(\Gamma)$. In fact, given any points of $S(\Gamma)$ there exists a countable dense set

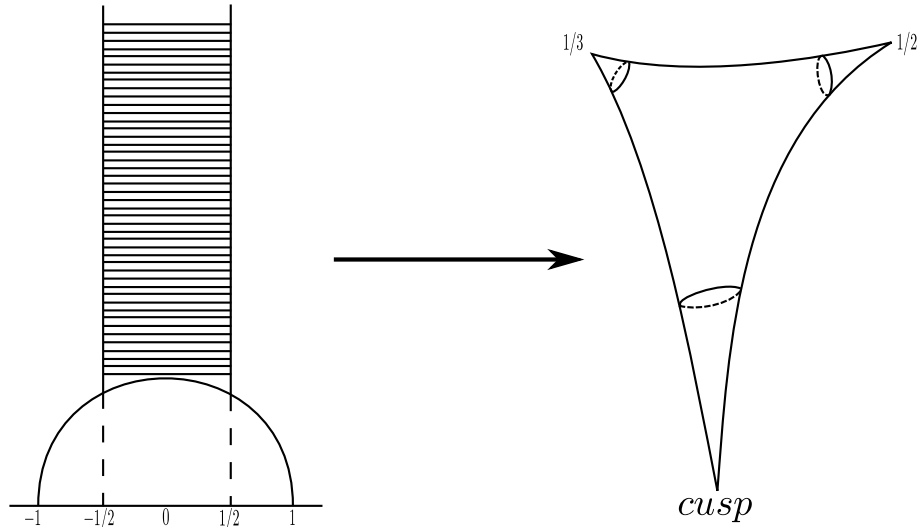

FIGURE 3

of unit tangent vectors at this point so that if we take a semi-geodesic starting at the point and tangent to the one of these vectors, then it will converge to the cusp. In the case of the modular group the angle between any two of these vectors at any point where two such semi-geodesics meet is a rational multiple of 2π . *This is one of the reasons why the modular orbifold carries so much arithmetical information.* The horocycles corresponding to the cusp are regularly immersed closed curves in $S(\Gamma)$. “Near” the cusp all such horocycles are embedded. A necessary condition for such a closed horocycle to be embedded is that its hyperbolic length is sufficiently small. However when the hyperbolic lengths of these closed horocycles are big, they are no longer embedded and they self-intersect. The number of self-intersections grows as their lengths grow and they tend to “fill up” all to $S(\Gamma)$. See figure 4).

We can assume by conjugation in G , that the cusp is the point at infinity in the upper half-plane so that the family of asymptotic geodesics associated to the cusp is the family of parallel vertical rays oriented in the upward direction. By conjugation we may also assume that the parabolic subgroup associated to the cusp in the following subgroup:

$$\Gamma_\infty = \left\{ \pm \begin{bmatrix} 1 & n \\ 0 & 1 \end{bmatrix} \mid n \in \mathbb{Z} \right\}$$

or equivalently, the group of translations: $T_n(z) = z + n$, $n \in \mathbb{Z}$. When the above happens we say that the point at infinity is the *standard cusp*. The modular group $\mathrm{PSL}(2, \mathbb{Z})$ has the standard cusp at infinity.

The horocycles corresponding to the standard cusp at infinity are the horizontal lines in the upper half-plane. By formula (0.3) we see that the points $((x, y), \pi)$ and $((x + 1, y), \pi)$

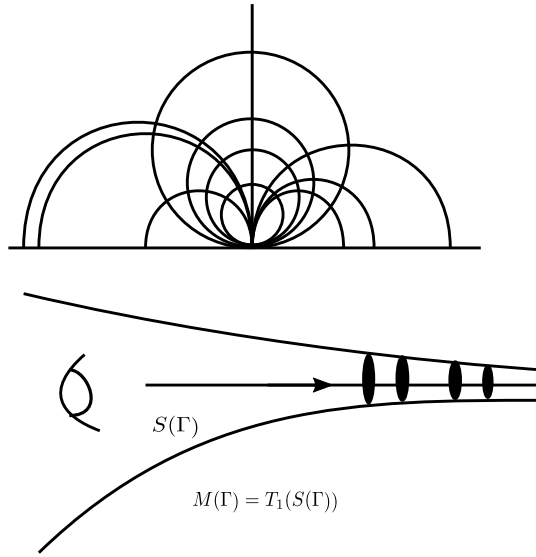

FIGURE 4

are identified by the differential of elements of Γ_∞ . Therefore, associated to the standard cusp there exists a one-parameter family of periodic orbits of h^+ in the unit tangent bundle of $S(\Gamma)$:

$$\gamma_y = \{((x, y), \pi) \in T_1(S(\Gamma)) \mid 0 \leq x \leq 1\} \quad (y > 0).$$

The periodic orbit γ_y has period (or length) $1/y$.

In general since any cusp can be taken to the standard cusp at infinity, we see that associated to the each cusp, there exists a one-parameter family of closed orbits for the horocycle flow where the natural parameter is the minimum positive period. Conversely, given any periodic orbit γ of h^+ , then γ is included in such one-parameter family. This is so since the diameter of $g_{-t}(\{\gamma\})$ tends to zero as t tends to infinity and thus it tends towards the point at infinity to some cusp. Exactly the same reasoning plus the fact the h^+ is ergodic with respect to m implies that the only minimal subsets of h^+ are $M(\Gamma)$ and horocycle periodic orbits. Using the “flip” map we see that everything we just said is also true for h^- .

As a consequence of the above remarks, we obtain that when Γ is a nonuniform lattice, there exist injective and densely immersed cylinders $C_i, i = 1, \dots, r$, where r is the number of cusp. These cylinders are mutually disjoint and their union comprises the totality of periodic orbits of h^+ . Naturally, these cylinders are distinct leaves of the unstable foliation of the geodesic flow. Everything that we have discussed so far follows by analyzing

the locally free actions of the affine group on $\mathrm{SL}(2, \mathbb{R})$ and on its quotients by discrete subgroups.

For nonuniform lattices Γ , the horocycle flows h^+ and h^- are not uniquely ergodic in $M(\Gamma)$ since both contain periodic orbits. For each periodic orbit γ of h^+ let $m(\gamma)$ denote the Borel probability measure which is supported in γ and which is uniformly distributed with respect to its arc-length i.e., if $f : M(\Gamma) \rightarrow \mathbb{R}$ is a continuous function, then

$$\langle m(\gamma), f \rangle := m_\gamma(f) = \frac{1}{T} \int_0^T f(h_t^+(x)) dt,$$

where $x \in \gamma$ is any point in γ and T is the period of γ . It is evident that $m(\gamma)$ is h^+ -invariant and it is ergodic for h^+ .

A theorem of Dani [4] asserts that the normalized standard Riemannian measure and measures of type $m(\gamma)$ are the only ergodic probability invariant measure for h^+ . It also follows from Dani's work that for a nonuniform lattice, an orbit of h^+ is either dense or else it is a periodic orbit.

Suppose that Γ has only one cusp and that this cusp is the standard cusp at infinity. Let $\widehat{M}(\Gamma)$ denote the one-point compactification of $M(\Gamma)$. Let us extend h^+ by keeping the point at infinity fixed. Let m_y denote the ergodic measure concentrated in the unique periodic orbit of period $1/y$. Let δ_∞ denote the Dirac measure at the point at infinity. Another result of Dani is that m_y converges weakly to the point-mass at infinity as $y \rightarrow \infty$ and m_y converges weakly to the normalized Haar measure \bar{m} , as $y \rightarrow 0$. The geometric significance of this result is clear: as the period decreases, the periodic orbit becomes smaller and tends to the cusp. On the other hand, as the period increases, the horocycle orbit gets longer and wraps around $M(\Gamma)$: it is almost dense. The latter case means that as the period grows the horocycle orbits tend to be uniformly distributed with respect to the normalized Haar measure.

Let $C^0(\widehat{M}(\Gamma))$ denote the Banach space of continuous real-valued functions of $\widehat{M}(\Gamma)$, with the sup norm. Let $C^* = [C^0(\widehat{M}(\Gamma))]^*$ denote its topological dual with the weak*-topology. Let

$$D : \mathbb{R}_\bullet^+ \rightarrow C^*; \quad D(y) = m_y, \quad (y > 0)$$

where \mathbb{R}_\bullet^+ denotes the multiplicative group of positive real numbers.

Dani's Theorem. [4]. *The measure m_y converges in the weak*-topology to the normalized Haar measure \bar{m} as $y \rightarrow 0$. The only ergodic measures of h^+ are $D(y)$ for $y > 0$, and \bar{m} .*

The weakly*-compact convex envelope of the image of the curve D is the set of all invariant probability measures of h^+ .

The rate of approach of m_y to the Haar measure \bar{m} (as $y \rightarrow 0$) is intimately related to the Riemann Hypothesis. Don Zagier [19] found a remarkable connection between the Riemann hypothesis and the horocycles in the orbifold $S(\mathrm{PSL}(2, \mathbb{Z})) = \mathrm{PSL}(2, \mathbb{Z}) \backslash \mathbb{H}$ (i.e., in the modular orbifold). Here we will use a particular case of Sarnak's result [16] (which generalizes

the previously mentioned theorem of Zagier) for the case $M = \mathrm{PSL}(2, \mathbb{R})/\mathrm{PSL}(2, \mathbb{Z})$:

Theorem (Zagier). *Let f any C^∞ function defined on M and with compact support. Then:*

$$(0.5) \quad m_y(f) = \overline{m}(f) + o(y^{1/2}), \quad (\text{as } y \rightarrow 0).$$

Furthermore, the above error term can be made to be $o(y^{3/4-\epsilon})$ for even $\epsilon > 0$ if and only if the Riemann Hypothesis is true.

P. Sarnak [16] developed Zagier's result to other discrete subgroups of $\mathrm{PSL}(2, \mathbb{R})$, namely nonuniform lattices. It will be clear that many of the ideas contained in the present paper (which incidentally, are reasonably simple and geometric) could be applied to these more general cases, at least when the nonuniform lattices are arithmetic (for example, for congruence subgroups).

In the present paper we will show that the exponent $1/2$ in the error term of (0.5) is optimal for certain characteristic functions χ_U . Namely, we will prove the following (see Theorem 3.22):

Theorem. *There exists an open set $U \subset M$ and a positive constant $K > 0$ depending only on U such that:*

$$(0.6) \quad |m_y(\chi_U) - \overline{m}(\chi_U)| \leq Ky^{1/2} |\log y|, \quad \text{for } 0 < y \leq 1/2.$$

Furthermore, if $\alpha > 1/2$, then

$$(0.6') \quad \overline{\lim}_{y \rightarrow 0} [|m_y(\chi_U) - \overline{m}(\chi_U)| y^{-\alpha}] = \infty.$$

Corollary. *The measure m_y becomes uniformly distributed with respect to Haar measure as $y \rightarrow 0$:*

$$\lim_{y \rightarrow 0} m_y(f) = \overline{m}(f) \quad \forall f \in C^0(\widehat{M}(\Gamma)).$$

(See also [4] and [19].)

Remark. Equality (0.6') does not imply that the Riemann Hypothesis is false since a characteristic function is not even continuous.

1. GEODESIC AND HOROCYCLE FLOWS

Let $U \subset M$ be a nonempty open set. Let γ_y be the horocycle orbit of period $1/y$. Then $\gamma_y \cap U$ is a (possibly infinite) union of open intervals in γ_y and $m_y(U)$ is the sum of the lengths of these intervals divided by the length of γ_y . For arbitrary U , to estimate how this grows as $y \rightarrow 0$ seems an impossible task. However, if we take special open sets this is indeed possible.

By a *standard box* (or simply a *box*) we will mean an open set in M which consists of the union of segments of orbits of h^+ of equal length and whose middle point is contained in a open “square” B (called the *base* of the box). The base B is contained in a stable leaf $L^- \in \mathcal{F}^-$, of the stable foliation of the geodesic flow. The boundary of B consists of two segments of geodesic orbits and two segments of stable horocycle orbits. See 5).

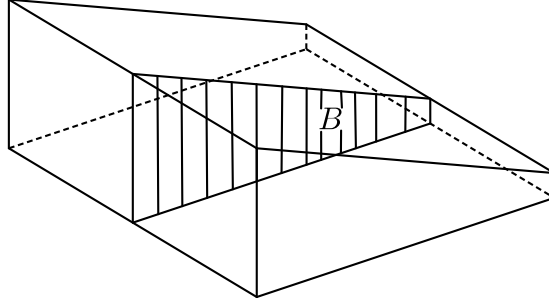

FIGURE 5

The base and the common length can be chosen small enough so as to have an embedded cube. In order to compute the volume (with respect to the normalized Haar measure) of a standard box it is better to take a lift of the box in the covering $\mathrm{SL}(2, \mathbb{R})$, compute the volume there, and then normalize. Let $C \subset \mathrm{SL}(2, \mathbb{R})$ be a box, let ℓ be the common length of the unstable segments of the box (to be called the “height” of the box). Denote by A the hyperbolic area of the base B . Then, as we will show latter:

$$m(C) = A\ell = (\text{area of base}) \times \text{“height”}.$$

A formula reminiscent of our elementary school days!

Therefore, if C is a box in M we obtain by normalization:

$$\bar{m}(C) = \frac{3}{\pi^2}(A\ell).$$

The set of all boxes in M is a basis of the topology of M and generates the σ -algebra of its Borel sets. Also, the image under the geodesic flow of a standard box is another standard box of equal volume (notice that a standard box is a foliated chart for the unstable foliation but not for the stable foliation).

Let γ_0 be the *basis unstable horocycle periodic orbit*, namely, the unique closed orbit of

$$h_t^+ : M \rightarrow M$$

which has period one. Then $\gamma_t := g_t(\gamma_0)$, as t runs over the real numbers, is the set of all closed orbits of h^+ . Clearly, γ_t has length and period e^t . Therefore, we have the change of parameter $y = e^{-t}$.

As t grows, γ_t becomes longer and starts “filling up” M , and it tends to be uniformly distributed with respect to the Haar measure. Let $C \subset M$ be a box with base B and let A and ℓ denote the area of the base and the height of C respectively. By the ergodic theorem no matter how small C is, at some time $T > 0$, γ_t will intersect C for all $t > T$.

We have the following formula:

$$(1.1) \quad m_y(C) = n(y, C)y\ell; \quad y = e^{-t}.$$

For all real t , γ_t intersects B transversally in a finite number of points $n(y, C)$ —the number that appears in the above formula. This formula is evident: $\gamma_t \cap C$ is a finite disjoint union of intervals of equal length ℓ . The number of these intervals is precisely $n(y, C)$ and we must divide by the length of γ_t which is $y^{-1} = e^t$ (see Figure 6).

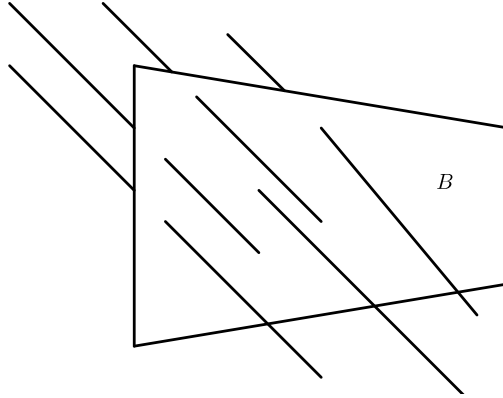

FIGURE 6

Figure 6 suggests Ampère’s Law of electromagnetism. Let us imagine a steady unit current flowing around the horocycle orbit γ_t then the normalized integral of the magnetic field induced in the boundary of the square is $n(y, C)$.

There is another way in which we can compute $m_y(C)$. Let $C_t = g_{-t}(C)$, ($t > 0$), be the image of a standard box by the geodesic flow reversing time. Then, since the geodesic flow preserves \bar{m} , we have:

$$\begin{cases} g_t(C_t \cap \gamma_1) = C \cap \gamma_t \\ \bar{m}(C_t) = \bar{m}(C); \quad t \in \mathbb{R}. \end{cases}$$

Let $B(t)$ be the base of C_t and let $A(t)$ be its area. Let $\ell(t)$ be the height of C_t . Then:

$$A(t) = e^t A(0) = e^t A,$$

where A is the area of the base of C . We also have:

$$\ell(t) = e^{-t} \ell(0) = e^{-t} \ell,$$

where ℓ is the height of C .

So as t goes to ∞ , the box C_t becomes very thin and the area of its base grows exponentially with t . There exists $T > 0$ such that C_t intersects the basic horocycle orbit γ_0 for all $t > T$. When this happens, $C_t \cap \gamma_0$ is a finite union of intervals in γ_0 of equal length ℓe^{-t} . The number of such intervals is $n(y, C)$ (see Figure 7).

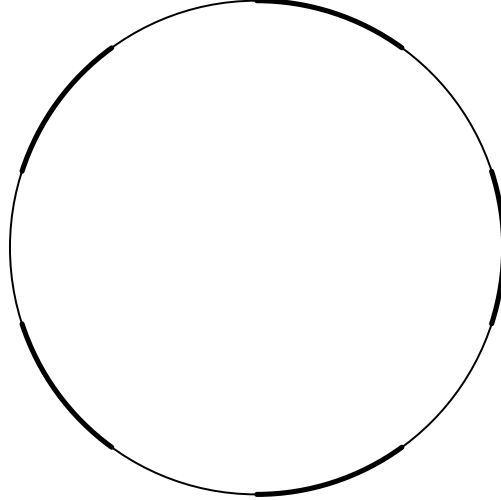

FIGURE 7

Let $J(y) = \{J_1(y), J_2(y), \dots, J_{n(y, C)}(y)\}$ be this collection of open intervals of equal length. The distribution of $J(y)$ in the basic horocycle orbit looks seemingly random. This is not exactly the case: the midpoints of the intervals are like a circular Farey sequence of order y^{-1} . The connection between the growth and distribution of circular Farey sequences and the Riemann Hypothesis are well-known theorems of Franel [6] and Landau [12] (see also Edwards [5, p. 263]). The problem of understanding the distribution of $J(y)$ can be viewed as a problem of equidistribution in the sense of Hermann Weyl.

We shall prove later that $J(y)$ has the pattern just described. In fact, we will show:

$$(1.2) \quad n(y, C) = \frac{3}{\pi^2} y^{-1} A + O(y^{1/2} \log y) \quad (\text{as } y \rightarrow 0).$$

Therefore, we see from (1.2) that:

$$\lim_{y \rightarrow 0} [y n(y, C)] = \frac{3}{\pi^2} A.$$

Using (1.1) we obtain:

$$(1.3) \quad \lim_{y \rightarrow 0} m_y(C) = \frac{3}{\pi^2} Al = \bar{m}(C).$$

Formula (1.3) implies that m_y converges vaguely to \bar{m} as $y \rightarrow 0$.

However, what is important for us is that the exponent $1/2$ in the error term in (1.2) is optimal. This will follow from the fact that $n(y, C)$ grows as a classical arithmetic function: the summatory of Euler's φ function:

$$\Phi(N) = \sum_{i=1}^N \varphi(i); \quad \Phi(r) = \sum_{n \leq r} \varphi(n) \quad \text{if } r \in \mathbb{R}, r \geq 1.$$

A classical theorem of Mertens (1874) shows that:

$$\Phi(r) = \frac{3}{\pi^2} r^2 + o(r \log r), \quad \text{as } r \rightarrow \infty.$$

We will apply Merten's theorem to prove:

Theorem 1.4. *(Compare with Theorem 3.18) With the above notation we have,*

$$n(y, C) \sim \Phi(y^{-1/2}),$$

where \sim denotes asymptotic equivalence as $y \rightarrow 0$.

Therefore, Merten's theorem will show the validity of (1.2). Incidentally, the number $\frac{3}{\pi^2} = \frac{1}{2}[\zeta(2)]^{-1}$ which appears in Mertens' formula is equal to the volume of M . Hence, weak convergence $m_y \rightarrow \bar{m}$ (as $y \rightarrow 0$) is equivalent to Mertens' theorem. This theorem appears in any standard text book in number theory, for instance, Apostol [2], Hardy and Wright [10] and Chandrasekharan [3]. See also [4].

2. SOME LEMMAS

Definition 2.1. Let Ω be the volume form in \tilde{G} such that:

$$\Omega_p(X_p, Y_p, Z_p) = 1, \forall p \in \tilde{G};$$

where $X_p, Y_p, Z_p \in T_p \tilde{G}$ are tangent vectors at p . Let $\langle \cdot, \cdot \rangle$ be the Riemannian metric such that $\{X, Y, Z\}$ is an oriented orthonormal framing. Let $\|\cdot\|$ be the norm induced by this metric.

Throughout this paper we will use this metric. The measure m determined by Ω is the *standard Riemannian measure or Haar measure*.

If $\Gamma \subset \text{SL}(2, \mathbb{R})$ is any discrete subgroup then X, Y, Z, Ω, m and $\langle \cdot, \cdot \rangle$ descend to $\tilde{M}(\Gamma) := \text{SL}(2, \mathbb{R})/\Gamma$, and they also descend to any quotient $\text{PSL}(2, \mathbb{R})/\Gamma$.

Definition 2.2. Let $M = \text{PSL}(2, \mathbb{R})/\text{PSL}(2, \mathbb{Z})$. We will let \bar{m} denote the normalized Haar measure: $\bar{m} = (3/\pi^2)m$.

Using the monomorphisms of the affine group into \tilde{G} given by formulae (0.4), we obtain the commutation rule:

$$(2.3) \quad \begin{bmatrix} a & 0 \\ 0 & a^{-1} \end{bmatrix} \begin{bmatrix} 1 & b \\ 0 & 1 \end{bmatrix} = \begin{bmatrix} 1 & a^2 b \\ 0 & 1 \end{bmatrix} \begin{bmatrix} a & 0 \\ 0 & a^{-1} \end{bmatrix}.$$

The modular function of the affine group is:

$$\alpha(a, b) = a^2.$$

As a manifold \tilde{G} is the product $S^1 \times \mathbb{R}^2$. The group \tilde{G} can be decomposed as a product in two ways using Iwasawa's decompositions: $\tilde{G} = \mathcal{N}\mathcal{A}\mathcal{K}$ and $\tilde{G} = \mathcal{A}\mathcal{N}\mathcal{K}$ where \mathcal{N} is the nilpotent group of matrices:

$$\mathcal{N} = \left\{ \begin{bmatrix} 1 & x \\ 0 & 1 \end{bmatrix} \middle| x \in \mathbb{R} \right\},$$

\mathcal{A} is the diagonal group:

$$\mathcal{A} = \left\{ \begin{bmatrix} a & 0 \\ 0 & a^{-1} \end{bmatrix} \middle| a > 0 \right\},$$

and \mathcal{K} is the compact circle group:

$$\mathcal{K} = \left\{ r(\theta) := \begin{bmatrix} \cos \theta & \sin \theta \\ -\sin \theta & \cos \theta \end{bmatrix} \middle| \theta \in \mathbb{R} \right\}.$$

Therefore any $\begin{bmatrix} a & b \\ c & d \end{bmatrix} \in \tilde{G}$ can be written in a unique way as follows:

$$\begin{bmatrix} a & b \\ c & d \end{bmatrix} = \begin{bmatrix} 1 & x \\ 0 & 1 \end{bmatrix} \begin{bmatrix} y & 0 \\ 0 & y^{-1} \end{bmatrix} \begin{bmatrix} \cos \theta & \sin \theta \\ -\sin \theta & \cos \theta \end{bmatrix}$$

where $x, \theta \in \mathbb{R}$ and $y > 0$.

Also it can be written in a unique way (using (2.3)) as follows:

$$\begin{bmatrix} a & b \\ c & d \end{bmatrix} = \begin{bmatrix} y & 0 \\ 0 & y^{-1} \end{bmatrix} \begin{bmatrix} 1 & y^{-2}x \\ 0 & 1 \end{bmatrix} \begin{bmatrix} \cos \theta & \sin \theta \\ -\sin \theta & \cos \theta \end{bmatrix}.$$

These two parametrizations of \tilde{G} give different expressions for the Haar measure written in terms of dx , dy and $d\theta$.

If $\begin{bmatrix} a & b \\ c & d \end{bmatrix} \in \tilde{G}$, then:

$$\begin{bmatrix} a & b \\ c & d \end{bmatrix} = \begin{bmatrix} (c^2 + d^2)^{-1/2} & 0 \\ 0 & (c^2 + d^2)^{1/2} \end{bmatrix} \begin{bmatrix} 1 & u \\ 0 & 1 \end{bmatrix} \begin{bmatrix} \cos \theta & \sin \theta \\ -\sin \theta & \cos \theta \end{bmatrix}$$

where $\cos \theta = d(c^2 + d^2)^{-1/2}$, $\sin \theta = c(c^2 + d^2)^{-1/2}$ and $u = \frac{1}{d}[b(c^2 + d^2) + c]$ if $d \neq 0$. If $d = 0$ then $bc = -1$, and if $c > 0$ we have

$$\begin{bmatrix} a & b \\ c & 0 \end{bmatrix} = \begin{bmatrix} c^{-1} & 0 \\ 0 & c \end{bmatrix} \begin{bmatrix} 1 & ca \\ 0 & 1 \end{bmatrix} \begin{bmatrix} 0 & -1 \\ 1 & 0 \end{bmatrix}.$$

This give the explicit \mathcal{AK} decomposition.

We also have, if $d \neq 0$,

$$\begin{bmatrix} a & b \\ c & d \end{bmatrix} = \begin{bmatrix} 1 & \frac{1}{d}[b + c(c^2 + d^2)^{-1}] \\ 0 & 1 \end{bmatrix} \begin{bmatrix} (c^2 + d^2)^{-\frac{1}{2}} & 0 \\ 0 & (c^2 + d^2)^{\frac{1}{2}} \end{bmatrix} \begin{bmatrix} \cos \theta & \sin \theta \\ -\sin \theta & \cos \theta \end{bmatrix}$$

if $d = 0$,

$$\begin{bmatrix} a & b \\ c & 0 \end{bmatrix} = \begin{bmatrix} 1 & ac^{-1} \\ 0 & 1 \end{bmatrix} \begin{bmatrix} c^{-1} & 0 \\ 0 & c \end{bmatrix} \begin{bmatrix} 0 & -1 \\ 1 & 0 \end{bmatrix}.$$

Let $A = \begin{bmatrix} a & b \\ c & d \end{bmatrix} \in \tilde{G}$, and let us write the unique decomposition

$$A = \begin{bmatrix} 1 & x \\ 0 & 1 \end{bmatrix} \begin{bmatrix} y & 0 \\ 0 & y^{-1} \end{bmatrix} \begin{bmatrix} \cos \theta & \sin \theta \\ -\sin \theta & \cos \theta \end{bmatrix}; \quad y > 0.$$

Then the map $\psi: \mathrm{SL}(2, \mathbb{R}) \rightarrow T_1\mathbb{H}$, which identifies $\mathrm{SL}(2, \mathbb{R})$ as a double covering of $\mathrm{PSL}(2, \mathbb{R}) := T_1\mathbb{H}$ is given by

$$\psi(A) = (x + iy^2, \frac{\pi}{2} - 2\arg(ci + d)).$$

Therefore the measure induced in $T_1\mathbb{H}$ by this identification is given by the volume form

$$dV = \frac{1}{2} \frac{dx \, dy \, d\theta}{y^2}.$$

Hence, if $U \subset T_1\mathbb{H}$ is any open set then by Fubini's theorem we have:

$$(2.4) \quad m(U) = \int_U dV = \frac{1}{2} \int_0^{2\pi} A_h(U(\theta)) d\theta,$$

where $U(\theta) = \{z \in \mathbb{H} \mid (z, \theta) \in U\}$ is the ‘‘slice’’ of U corresponding to θ and

$$A_h(U(\theta)) = \iint_{U(\theta)} \frac{dx \, dy}{y^2}$$

is its hyperbolic area.

From Formula (2.4) we obtain that if $U \subset T_1\mathbb{H}$ is S^1 -saturated (i.e. it is a union of circle fibers), $U = D \times S^1$, then

$$m(U) = \pi A_h(D).$$

In particular if we take the fundamental domain of the action of $\mathrm{PSL}(2, \mathbb{Z})$ in $T_1\mathbb{H}$ consisting of all unit tangent vectors based in the modular fundamental domain in \mathbb{H} we have:

$$m(M) = 3/\pi^2.$$

Now let $A = A(u, t, v) \in \tilde{G}$ be as follows:

$$(2.5) \quad A = \begin{bmatrix} 1 & u \\ 0 & 1 \end{bmatrix} \begin{bmatrix} e^{t/2} & 0 \\ 0 & e^{-t/2} \end{bmatrix} \begin{bmatrix} 1 & 0 \\ v & 1 \end{bmatrix} = \begin{bmatrix} e^{t/2} + uve^{-t/2} & ue^{-t/2} \\ ve^{-t/2} & e^{-t/2} \end{bmatrix}.$$

then $\alpha(A) = e^{t/2}(v^2 + 1)^{-1/2}$, so we have:

$$(2.6) \quad A = \begin{bmatrix} 1 & u + e^t(v^2 + 1)^{-1}v \\ 0 & 1 \end{bmatrix} \begin{bmatrix} e^{t/2}(v^2 + 1)^{-1/2} & 0 \\ 0 & e^{-t/2}(v^2 + 1)^{1/2} \end{bmatrix} \\ \cdot \begin{bmatrix} (v^2 + 1)^{-1/2} & -v(v^2 + 1)^{-1/2} \\ v(v^2 + 1)^{-1/2} & (v^2 + 1)^{-1/2} \end{bmatrix}$$

Then (2.6) is the \mathcal{NAK} decomposition of A and we have:

$$\cos \theta = (v^2 + 1)^{-1/2}, \quad \sin \theta = -v(v^2 + 1)^{-1/2}, \quad \text{and } v = -\tan \theta.$$

Let $\tilde{U} \subset \text{SL}(2, \mathbb{R})$ be the closed set:

$$\tilde{U} = \{A(u, t, v) \mid u_0 \leq u \leq u_1, v_0 \leq v \leq v_1, t_0 \leq t \leq t_1\}$$

where $A(u, t, v)$ is defined in (2.5).

Let $U \subset \text{PSL}(2, \mathbb{R})$ be the projection of \tilde{U} . Then:

$$m(U) = \frac{1}{2} \int_{\theta_1}^{\theta_0} k(\theta) d\theta$$

where $\theta_0, \theta_1 \in (-\pi/2, \pi/2)$ are the unique numbers such that $v_0 = -\tan \theta_0$ and $v_1 = -\tan \theta_1$, and where $k(\theta) = A_h(U(\theta))$.

Using formula (2.6) we obtain for $\theta_1 \leq \theta \leq \theta_0$:

$$U(\theta) = \{(-(1/2)e^t \sin(2\theta) + u) + (e^t \cos^2 \theta)i \mid u_0 \leq u \leq u_1, t_0 \leq t \leq t_1\} \subset \mathbb{H}.$$

We have that $U(\theta)$ has the same hyperbolic area as:

$$V(\theta) = \{u \sec^2 \theta + e^t i \mid t_0 \leq t \leq t_1, u_0 \leq u \leq u_1\}.$$

This is so since $V(\theta)$ is obtained from $U(\theta)$ by the hyperbolic isometry:

$$T_\theta(z) = (\sec^2 \theta)z + \frac{1}{2}e^t(\sec^2 \theta)(\sin 2\theta); \quad z \in \mathbb{H}, \theta_1 \leq \theta \leq \theta_0.$$

We thus obtain:

Proposition 2.7.

$$A_h(U(\theta)) = A_h(V(\theta)) = \left[\int_{t_0}^{t_1} \int_{u_0}^{u_1} \frac{dx dy}{y^2} \right] \sec^2 \theta = (u_1 - u_0)(e^{-t_0} - e^{-t_1}) \sec^2 \theta$$

Therefore:

$$\begin{aligned}
 m(U) &= \frac{1}{2}(u_1 - u_0)(e^{-t_0} - e^{-t_1}) \int_{\theta_0}^{\theta_1} \sec^2 \theta \, d\theta \\
 &= \frac{1}{2}(u_1 - u_0)(e^{-t_0} - e^{-t_1}) \int_{\theta_0}^{\theta_1} d(\tan \theta) \\
 &= \frac{1}{2}(u_1 - u_0)(e^{-t_0} - e^{-t_1}) \int_{\theta_0}^{\theta_1} dv \\
 &= \frac{1}{2}(u_1 - u_0)(e^{-t_0} - e^{-t_1})(v_1 - v_0)
 \end{aligned}$$

i.e.

$$(2.8) \quad m(U) = \frac{1}{2}(u_1 - u_0)(v_1 - v_0)(e^{-t_0} - e^{-t_1})$$

Another way to compute $m(\tilde{U})$ is the following. Let $I \subset \mathbb{R}^3$ be the cube:

$$I = \{(u, t, v) \in \mathbb{R}^3 \mid u_0 \leq u \leq u_1 \quad v_0 \leq v \leq v_1 \quad t_0 \leq t \leq t_1\}.$$

Let $\varphi: I \rightarrow \tilde{U}$ be the parametrization of \tilde{U} given by $\varphi(u, t, v) := A(u, t, v)$, where $A(u, t, v)$ is given by (2.5). Let $\partial_u = \frac{\partial}{\partial u}$, $\partial_t = \frac{\partial}{\partial t}$, $\partial_v = \frac{\partial}{\partial v}$ be the standard vector fields in I . Then, $(\varphi_*(\partial_u)_{(u,t,v)}, \varphi_*(\partial_t)_{(u,t,v)}, \varphi_*(\partial_v)_{(u,t,v)})$ is a basis for the tangent space $T_{A(u,t,v)}\tilde{G}$. Comparing this basis with the basis $(X_{A(u,t,v)}, Y_{A(u,t,v)}, Z_{A(u,t,v)})$ given by the basic vector fields at $A(u, t, v)$, we see that the change of bases is given by the matrix:

$$\begin{bmatrix} 1 & 0 & 0 \\ -v & 1 & 0 \\ -v^2 e^{-t} & v e^{-t} & e^{-t} \end{bmatrix}$$

Since the determinant of this matrix is e^{-t} we have:

$$\begin{aligned}
 (2.9) \quad \frac{1}{2}m(\tilde{U}) &= \frac{1}{2} \int_{u_0}^{u_1} \int_{t_0}^{t_1} \int_{v_0}^{v_1} e^{-t} \, du \, dt \, dv \\
 &= \frac{1}{2}(u_1 - u_0)(v_1 - v_0)(e^{-t_0} - e^{-t_1}).
 \end{aligned}$$

Let us consider now the geodesic flow $g_t: \tilde{G} \rightarrow \tilde{G}$. We have for $t \in \mathbb{R}$ and $p \in \tilde{G}$:

$$g_t^*(Y_p) = e^t Y_{g_t(p)} \quad g_t^*(Z_p) = e^{-t} Z_{g_t(p)},$$

where g_t^* is the differential. Then:

$$\|g_t^*(Y_p)\| = e^t \|Y_p\| \quad \|g_t^*(Z_p)\| = e^{-t} \|Z_p\|.$$

Hence, $\{g_t\}$ is an Anosov flow leaving invariant the splitting:

$$T\tilde{G} = E^+ \oplus E^- \oplus E$$

where in this Whitney sum E^+ , E^- and E are the line bundles spanned by Y , Z and X respectively. The fact that g is Anosov implies that it is structurally stable and its periodic orbits are dense. This accounts for its very rich dynamics.

The differential of the geodesic flow acts on the canonical framing as follows:

$$g_t^*(X_p, Y_p, Z_p) = (X_{g_t(p)}, e^t Y_{g_t(p)}, e^{-t} Z_{g_t(p)})$$

Therefore, the Jacobian of g_t is identically equal to one and the geodesic flow preserves Ω . A similar calculation shows that Ω is also preserved by h^+ and h^- .

The circle group \mathcal{K} is the one-parameter subgroup corresponding to $\begin{bmatrix} 0 & 1 \\ -1 & 0 \end{bmatrix} \in \mathfrak{sl}(2, \mathbb{R})$.

Therefore the vector field $W = Y - Z$ induces a free action of the circle on \tilde{G} . The foliations \mathcal{F}^+ and \mathcal{F}^- tangent to $E^+ \oplus E$ and $E^- \oplus E$ are respectively the unstable and stable foliations of the geodesic flow and are also obtained by left translations of the two copies of the affine group in \tilde{G} . Both foliations are transverse to W and every leaf of these foliations intersects each circular orbit of W in exactly one point. *This is the geometric interpretation of the two Iwasawa decompositions.* Given any measure (or more generally, any Schwartz distribution) one can disintegrate the given measure with respect to each of the foliations. If $\Gamma \subset \tilde{G}$ is any discrete subgroup, then the vector field W descends to $\tilde{G}/\Gamma = M(\Gamma)$ and induces a periodic flow which gives $M(\Gamma)$ the structure of a Seifert fibration over a hyperbolic orbifold. The foliations \mathcal{F}^+ and \mathcal{F}^- descend to $M(\Gamma)$ and their leaves are transverse to the fibres of the Seifert fibration. If $m(M(\Gamma)) < \infty$ then every leaf is dense. With respect to the induced metric, each leaf in any of the two foliations is isometric to \mathbb{H} . Formula (2.8) can be obtained directly by disintegration.

Definition. Let $x \in \tilde{G}$. Let a, b and c be positive reals. Then a *standard box* or simply a *closed box*, denoted by $C(x; a, b, c)$, or simply by C if the parameters are understood, is the subset of \tilde{G} defined as follows:

$$C(x; a, b, c) = \left\{ h_v^-(g_t(h_u^+(x))) \mid v \in \left[-\frac{a}{2}, \frac{a}{2}\right], t \in \left[-\frac{b}{2}, \frac{b}{2}\right], u \in \left[-\frac{c}{2}, \frac{c}{2}\right] \right\}.$$

We call x the *center of the box*.

Remark 2.10.

- (i) The image under the geodesic flow of a closed box is another closed box:

$$g_t(C(x; a, b, c)) = C(g_t(x); e^{-t}a, b, e^t c); \quad t \in \mathbb{R}.$$

- (ii) Any left-translation of a box is also a box:

$$\alpha C(x; a, b, c) = C(\alpha x; a, b, c); \quad \alpha \in \tilde{G}.$$

- (iii) Since the center and the parameters of the box can be chosen arbitrarily, it follows that the interiors of the boxes (i.e. the *open boxes*) generate the topology of \tilde{G} and the σ -algebra of its Borel subsets.

Let us compute the Haar measure of the box $C := C(x; a, b, c)$. Using a left translation by x^{-1} and the fact that \tilde{G} is unimodular, it is enough to compute the volume with parameters $(e; a, b, c)$ where e is the identity element. But in this case using formula (2.9) we have:

Lemma 2.11. $m(C(x; a, b, c)) = ac(e^{b/2} - e^{-b/2}) = 2ac[\sinh(\frac{b}{2})]$.

Let us return now \mathcal{F}^+ and \mathcal{F}^- . If $x \in \tilde{G}$, let us denote by $L^+(x)$ and $L^-(x)$ the leaves of \mathcal{F}^+ and \mathcal{F}^- which contain the point x . Explicitly:

$$\begin{aligned} L^+(x) &= \{h_u^+(g_t(x)) \mid u, t \in \mathbb{R}\} \\ L^-(x) &= \{h_v^-(g_t(x)) \mid v, t \in \mathbb{R}\}. \end{aligned}$$

Definition. Let $C = C(x; a, b, c)$ be a closed box. Then the base of C is:

$$\beta(C) := \left\{ g_t(h_u^-(x)) \mid -\frac{c}{2} \leq u \leq \frac{c}{2}, -\frac{b}{2} \leq t \leq \frac{b}{2} \right\}$$

Clearly, we have $\beta(C) \subset L_-(x)$ and $A_h(\beta(C)) = 2c \sinh(\frac{b}{2})$.

From now on we will work in $G = \text{PSL}(2, \mathbb{R})$ and in $M = \text{PSL}(2, \mathbb{R})/\text{PSL}(2, \mathbb{Z})$. In these two manifolds we have the unstable and stable foliations \mathcal{F}^+ and \mathcal{F}^- .

We define standard boxes in M exactly the same way. In fact, they are the projections of the boxes in \tilde{G} . However, we will only consider *embedded* boxes in M . If $C = C(x; a, b, c) \subset G$ is a box, then:

$$m(C) = ac(\sinh(b/2)).$$

If $C = C(x; a, b, c) \subset M$, then its Haar measure is given by

$$\bar{m} = \frac{3}{\pi^2} ac(\sinh(b/2)).$$

Let us recall the identification $\psi: \text{PSL}(2, \mathbb{R}) \rightarrow T_1\mathbb{H}$, which assigns to each Möbius transformation $\sigma(z) = \frac{az+b}{cz+d}$, the point in $T_1\mathbb{H}$ by the formula:

$$\psi(\sigma) = \left(\sigma(i), -\frac{\sigma'(i)i}{|\sigma'(i)|} \right).$$

The action of $\text{PSL}(2, \mathbb{R})$ on $T_1\mathbb{H} = \{(z, \theta) \mid z \in \mathbb{H}, \theta \pmod{2\pi}\}$ is given by:

$$\sigma(z, \theta) = (\sigma(z), \theta - 2\arg(cz + d)), \quad \sigma(z) = \frac{az + b}{cz + d}.$$

(Recall that the angles are measured counter-clockwise from the vertical.)

Let $L^+(e)$ and $L^-(e)$ be the unstable and stable leaves through the identity $e \in G$.

Definition. $\psi(L^+(e)) := L^+$ and $\psi(L^-(e)) := L^-$ are the *basic unstable and basic stable leaves*, respectively:

$$\begin{aligned} L^+ &= \{(x + iy, \pi) \in T_1\mathbb{H}\} \\ L^- &= \{(x + iy, 0) \in T_1\mathbb{H}\}. \end{aligned}$$

Definition. An *adapted box* $C \subset G$ is a standard box such that $\beta(C) \subset L^-$.

If $\alpha \in G$ and $C(\alpha; a, b, c)$ is an adapted box centered at α , then $\alpha = (x_0 + iy_0, 0)$ and

$$\beta(C) = \{(x + iy, 0) \mid y_0 e^{-\frac{b}{2}} \leq y \leq y_0 e^{\frac{b}{2}}, |x - x_0| \leq ay_0/2\}$$

(See Figure 8).

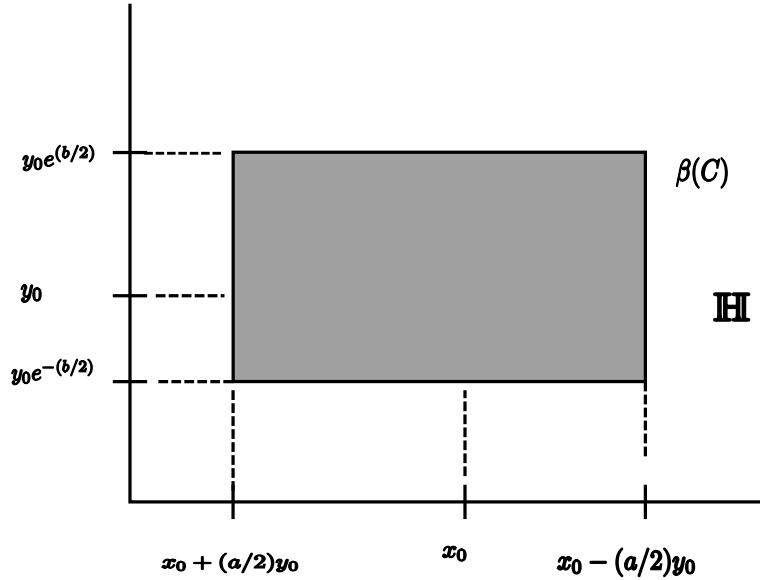

FIGURE 8

We see that bases of adapted boxes can be identified with rectangles in \mathbb{H} whose sides are parallel to the coordinate axis. We will not distinguish the base and the corresponding rectangle in \mathbb{H} .

Let $p: G \rightarrow M$ be the covering projection and let $\bar{P}: M \rightarrow S((\text{PSL})(2, \mathbb{Z}))$ be the Seifert fibration onto the modular orbifold. Then $P(L^+)$ and $P(L^-)$ are called the *basic unstable and stable leaves* of the corresponding geodesic flow. $P(L^+)$ and $P(L^-)$ are the cylinders mentioned before which contain all periodic orbits of h^+ and h^- respectively.

Both $P(L^+)$ and $P(L^-)$ are dense in M . If $z \in S(\mathrm{PSL}(2, \mathbb{Z}))$ and $S^1(z) = \overline{P}^{-1}(z)$ denotes the circular fibre over z , then

$$\begin{aligned} L^+(\mathbb{Q}) &:= S^1(z) \cap P(L^+) \\ L^-(\mathbb{Q}) &:= S^1(z) \cap P(L^-) \end{aligned}$$

have the property that if $\alpha, \beta \in L^+(\mathbb{Q})$ (or $L^-(\mathbb{Q})$) then there exists $\theta_0 \in \mathbb{Q}$ such that

$$r_{\pi\theta_0}(\alpha) = \beta$$

where $r_\theta: M \rightarrow M$, $\theta \in \mathbb{R}$ is the periodic flow induced by $W = Y - Z$.

This simple fact happens to be very important for number theory. The reason is clear (apart from the fact that the rationals are involved): any invariant measure for h^+ corresponds to a Choquet measure on the image of the curve $D: [0, \infty] \rightarrow C^*$. If this measure has compact support (or even if the density of a Choquet measure at $D(0)$ and $D(\infty)$ decays very rapidly as $y \rightarrow 0$ or $y \rightarrow \infty$) then the corresponding probability invariant measure for h^+ is concentrated in $P(L^+)$.

Let \mathcal{C} denoted the set of all boxes in M which are adapted, i.e., $C \in \mathcal{C} \iff \beta(C) \subset P(L^-)$. Then \mathcal{C} is a basis for the topology of M . Hence, to see how the measure m_y , approach the normalized Haar measure \overline{m} , it is enough to estimate with precision $m_y(C)$ for all $C \in \mathcal{C}$.

For each $t \in \mathbb{R}$, let Λ_t be the horizontal line which is parametrized by:

$$\lambda_t(s) = s + e^{-t}i; \quad s \in \mathbb{R}.$$

Let $\hat{\lambda}_t: \mathbb{R} \rightarrow T_1\mathbb{H}$ be defined by $\hat{\lambda}_t(s) = (\lambda_t(s), \pi)$. Thus λ_t parametrizes the horocycle with equation $y = e^{-t}$ and $P \circ \hat{\lambda}_t$ parametrizes with arcl-length as parameter the unstable horocycle orbit of period $y = e^{-t}$, i.e. it parametrizes:

$$\gamma_t = g_t(\gamma_0).$$

Let $A = \begin{bmatrix} a & b \\ c & d \end{bmatrix} \in \mathrm{SL}(2, \mathbb{Z})$, $c \neq 0$. Let $\bar{A}(z) = \frac{az+b}{cz+d}$ denote the corresponding modular Möbius transformation and let $A': T_1\mathbb{H} \rightarrow T_1\mathbb{H}$ be the induced map in the unit tangent bundle. The image of Λ_t under \bar{A} is the horocycle which is the circle tangent to the real axis at the point $\frac{a}{c}$ and whose highest point is:

$$(2.12) \quad z = \frac{a}{c} + e^t c^{-2}i; \quad (c \neq 0).$$

This fact follows immediately since the point with biggest ordinate in $\bar{A}(\Lambda_t)$ corresponds to the unique real number s_0 for which $\frac{d}{ds}(\bar{A} \circ \lambda_t)|_{s=s_0}$ is real. Hence $s_0 = -\frac{d}{c}$. We also obtain that $A'(\gamma_t)$ intersects L^- only at the point:

$$\left(\frac{a}{c} + e^t c^{-2}i, 0 \right) \in L^-, \quad (c \neq 0).$$

When $c = 0$, then \bar{A} is a horizontal translation by an integer and Λ_t and γ_t are kept invariant by \bar{A} and A' respectively.

Definition. For $t = 0$ we have the basic horocycle:

$$H_1 = \{(x, y) \in \mathbb{H} \mid x \in \mathbb{R}\} = \Lambda_0.$$

The *basic horoball* is the boundary of H_1 in the extended hyperbolic plane (the closure of \mathbb{H} in the Riemann sphere):

$$B_1 = \{(x, y) \in \mathbb{H} \mid \infty \geq y \geq 1\}.$$

The images by elements of $\mathrm{PSL}(2, \mathbb{Z})$ of the basic horocycle are called the *Ford circles* and the images of the basic horoball are called the *Ford discs*.

Two Ford discs either coincide or else they are tangent at a point in \mathbb{H} and have disjoint interiors. The hyperbolic area of a Ford disc is one.

It follows from formula (2.12) that the Ford discs are tangent to the real axis at rational points (except for the basic horoball which is tangent at the point at infinity), and every rational point is a point of tangency. all these facts are important for number theory (read the very last paragraph in Rademacher's classic book in complex functions). (See Figure 9).

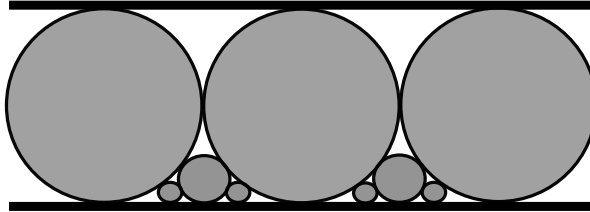

FIGURE 9

Let \mathcal{F} be the set of all Ford discs that intersect the strip $0 \leq x \leq 1$, $y > 0$. For $r > 0$ let F_r denote the subset of Ford discs in \mathcal{F} that intersect the half-plane $y \geq r^{-1}$. Then the circles in F_r are tangent to the real axis at exactly the rational points in $[0, 1]$ which belong to the Farey sequence of order $r^{1/2}$. Therefore, its cardinality $|F_r|$ is given by

$$|F_r| = \sum_{n \leq r^{1/2}} \varphi(n) := \Phi(r^{1/2}),$$

where φ denotes Euler's *totient function*. Everything follows just by looking at formula (2.12).

Let Q be a rectangle which corresponds to the base of an adapted box C . For each $t \in \mathbb{R}$ let $T_1 : \mathbb{H} \rightarrow \mathbb{H}$ be defined by

$$(2.13) \quad T_t(x, y) = (x, e^{-t}y)$$

and let $Q_t = T_t(Q)$. Then Q_t is the base of the adapted box $g_{-t}(C)$.

As $t \rightarrow \infty$, Q_t starts intersecting more and more Ford discs. Let $n(t)$ denote the number of Ford discs whose highest point is contained in Q_t , then $n(t)$ has the same growth type as that of Farey sequences contained in a fixed interval.

At this point it is clear the connection between Farey sequences, the ergodic measures of the horocycle flow in M and the Riemann hypothesis. This is the link between Zagier's result [19] and the following theorems of Franel [6] and Landau [12]:

Teorema (Franel-Landau). *Let $F_N = \{f_1, f_2, \dots, f_{\Phi(N)}\}$ be the Farey sequence of order N consisting of reduced fractions $\frac{a}{b} \in (0, 1]$, arranged in order of magnitude. Let $\delta_n = f_n - \frac{n}{\Phi(N)}$, ($n = 1, \dots, \Phi(N)$) be the amount of discrepancy between f_n and the corresponding fraction obtained by equi-dividing the interval $[0, 1]$ into $\Phi(N)$ equal parts. Then, a necessary and sufficient condition for the Riemann hypothesis is that:*

$$\sum_{i=1}^{\Phi(N)} \delta_i^2 = O\left(\frac{1}{N^{1-\epsilon}}\right) \quad \text{for all } \epsilon > 0, \text{ (Franel).}$$

An alternative necessary and sufficient condition is that:

$$\sum_{i=1}^{\Phi(N)} |\delta_i| = O(N^{\frac{1}{2}+\epsilon}) \quad \text{for all } \epsilon > 0, \text{ (Landau).}$$

The subgroup of integer translations of the modular group identifies $(x, y) \in \mathbb{H}$ with $(x+n, y) \in \mathbb{H}$, and $((x, y), 0)$ with $((x+n, y), 0)$; $n \in \mathbb{Z}$. Since we want adapted boxes in M which are embedded, it is enough to consider standard boxes in M which are projections of standard boxes in $T_1\mathbb{H}$ whose bases lie in the half-open strip $0 < x \leq 1$ (See Figure 10).

Let $C \subset M$ be a box such that $\beta(C)$ is the rectangle $Q := Q(\alpha_1, \alpha_2; \beta_1, \beta_2)$, where $0 < \alpha_1 < \alpha_2 \leq 1, 0 < \beta_1 < \beta_2$, defined by:

$$Q = \{(x, y) \in \mathbb{H} \mid \alpha_1 \leq x \leq \alpha_2, \beta_1 \leq y \leq \beta_2\}.$$

we have that $\beta(g_{-t}(C)) = T_t(\beta(C))$ where T_t is given by formula (2.13). Therefore:

$$\begin{aligned} n(t) &:= \#\{g_t(\gamma_0) \cap \beta(C)\} = \#\{\gamma_0 \cap g_t(C)\} \\ &= \#\{\bar{A} \in \text{PSL}(2, \mathbb{Z}) \mid A'(\gamma_t) \cap \{((x, y), 0) \in T_1\mathbb{H} \mid (x, y) \in Q\} \neq \emptyset\} \\ &= \#\left\{A = \begin{bmatrix} a & b \\ c & d \end{bmatrix} \in \text{SL}(2, \mathbb{Z}), c \neq 0 \mid A'(\gamma_t) \cap \{((x, y), 0) \in T_1\mathbb{H} \mid (x, y) \in Q\} \neq \emptyset\right\} \\ &= \#\{(a, c) \in \mathbb{Z}^+ \times \mathbb{Z}^+ \mid c \neq 0, \{a, c\} = 1, (a/c + e^t c^{-2}i) \in Q\} \\ &= \#\{(a, c) \in \mathbb{Z}^+ \times \mathbb{Z}^+ \mid c \neq 0, \{a, c\} = 1, \alpha_1 \leq a/c \leq \alpha_2, e^{\frac{t}{2}}\beta_2^{-\frac{1}{2}} \leq c \leq e^{\frac{t}{2}}\beta_1^{-\frac{1}{2}}\}. \end{aligned}$$

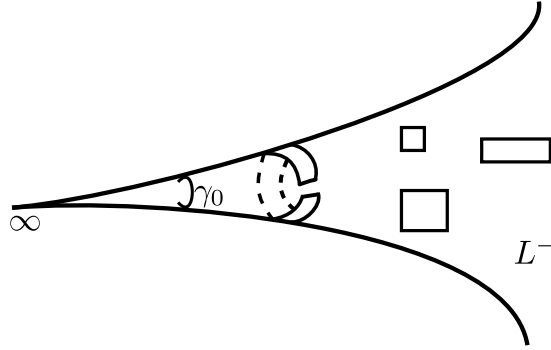

FIGURE 10

We thus have the following:

Proposition. *The number of points in which the horocycle orbit $g_t(\gamma_0)$ intersects the base of the box $\beta(C)$ as a function of t is given by*

$$(2.14) \quad n(t) = \#\{(a, c) \in \mathbb{Z}^+ \times \mathbb{Z}^+ \mid c \neq 0, \{a, c\} = 1, \alpha_1 \leq a/c \leq \alpha_2, e^{\frac{t}{2}} \beta_2^{-\frac{1}{2}} \leq c \leq e^{\frac{1}{2}} \beta_1^{-\frac{1}{2}}\}.$$

Let $\mathbb{R}_+^2 = \{(u, v) \in \mathbb{R}^2 \mid v > 0\}$ denote the open upper half-plane with the Euclidean metric.

Let $\Psi: \mathbb{R}_+^2 \rightarrow \mathbb{H}$, be the function:

$$(2.15) \quad \Psi(u, v) = \frac{u}{v} + v^{-2}i, \quad (v > 0).$$

This simple function has the following remarkable properties:

Proposition. *Ψ is an orientation-reversing diffeomorphism from the upper euclidean half-plane onto the hyperbolic plane. It sends rays emanating from the origin onto the family of geodesics which are vertical lines and the family of horizontal lines onto the family of horizontal horocycles. The absolute value of the Jacobian of Ψ , with respect to the Euclidean and hyperbolic metric is 2. Therefore, $A_e(U) = \frac{1}{2}A_h(\Psi(U))$ where $U \subset \mathbb{R}_+^2$ is any open set and A_e, A_h denote the Euclidean and hyperbolic areas, respectively. Ψ sends the integer lattice points with relatively prime coordinates in the euclidean upper half-plane onto the points of tangency of the Ford circles in the hyperbolic plane.*

The usefulness of this proposition is that *it reduces the problem of counting the number of intervals in which a closed horocycle intersects a box to a euclidean lattice point counting*

Let Δ be any trapezium in \mathbb{R}_+^2 whose boundary consists of two horizontal lines and two segments which are collinear to the origin. Then $\Psi(\Delta)$ is a rectangle in \mathbb{H} whose sides are parallel to the coordinates axis (See Figure 11).

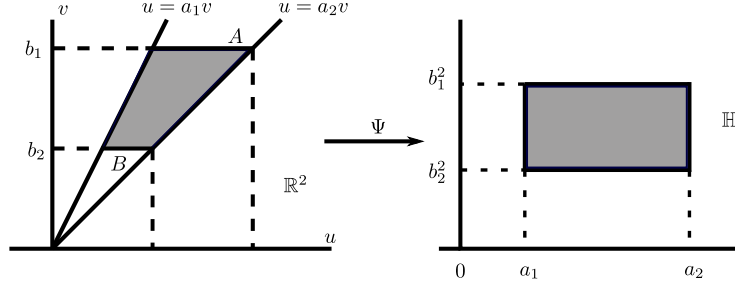

FIGURE 11

If Δ is bounded by the lines $u = a_1v$, $u = a_2v$ and the lines $v = b_1$, $v = b_2$, then $\Psi(\Delta) = \{(x, y) \in \mathbb{H} \mid a_1 \leq x \leq a_2, b_1^{-2} \leq y \leq b_2^{-2}\}$. then,

$$A_e(\Delta) = \frac{(a_2 - a_1)(b_1^2 - b_2^2)}{2}$$

and

$$-\frac{1}{2}A_h(\Psi(\Delta)) = \int_{b_1^{-2}}^{b_2^{-2}} \int_{a_1}^{a_2} \frac{dx dy}{y^2} = \frac{a_2 - a_1}{2} \int_{b_1^{-2}}^{b_2^{-2}} \frac{dy}{y^2} = \frac{1}{2}(a_2 - a_1)(b_1^2 - b_2^2)$$

Therefore

$$(2.16) \quad A_e(\Delta) = \frac{1}{2}A_h(\Psi(\Delta))$$

Of course we knew (2.16) since the Jacobian of Ψ is -2 , but we wanted this fact explicit (in fact the formula (2.16) for all trapezia implies that the Jacobian is ± 2).

For each $t \in \mathbb{R}$, let $\mu_t: \mathbb{R}_+^2 \rightarrow \mathbb{R}_+^2$ be the homothetic transformation:

$$(2.17) \quad \mu_t(u, v) = (e^{t/2}u, e^{t/2}v).$$

Let $\Delta(t) = \mu_t(\Delta(0))$, for $t \in \mathbb{R}$, where $\Delta(0) = \Delta$ is the trapezium of the previous paragraph. Let T_t be the transformation defined by formula (2.13), then we have :

$$(2.18) \quad \Psi \circ \mu_t = T_t \circ \Psi.$$

Hence, by formula (2.14) we have:

$$(2.19) \quad n(t) = \#\{(a, b) \in \mathbb{Z}^+ \times \mathbb{Z}^+ \mid \{a, c\} = 1, (a, b) \in \Delta(t)\}.$$

3. MAIN RESULTS

Now, all that it is left is to estimate $n(t)$. We will need the following:

Theorem 3.1 (Mertens). *Let $0 < \alpha_1 < \alpha_2 \leq 1$. For each $\ell > 2$, let $\tau(\ell)$ be the triangle in \mathbb{R}_+^2 defined by*

$$\tau(\ell) = \{(u, v) \in \mathbb{R}_+^2 \mid v \leq \ell, \alpha_1 \leq \frac{u}{v} \leq \alpha_2\}.$$

Let $N(\ell)$ be the number of lattice points with relatively prime integral coordinates contained in $\tau(\ell)$. The

$$N(\ell) = \frac{6}{\pi^2} A_e(\tau(\ell)) + \eta(\ell)\ell \log \ell,$$

where $|\eta(\ell)|$ is bounded by $(2 + 2\sqrt{2})(1 + 1/\log 2) < 24$ for all $\ell \geq 2$.

Proof. This result is classical and the method of proof starts with Gauss. However, I will give a proof here since I will need the method for the following lemmas. I will adapt the proof given in Chandrasekharan [Ch. p. 59].

$A(\ell) = A(1)\ell^2 = (\alpha_2 - \alpha_1)\ell^2/2$, and $p(\ell) = p(1)\ell$ be the Euclidean area and perimeter of $\tau(\ell)$, respectively. Let

$$K(\ell) = \{(a, b) \in \mathbb{Z}^+ \times \mathbb{Z}^+ \mid (a, b) \in \tau(\ell)\},$$

and let $\bar{N}(\ell) = |K(\ell)|$ be its cardinality. Then

$$A(\ell) - \sqrt{2}p(\ell) \leq \bar{N}(\ell) \leq A(\ell) + \sqrt{2}p(\ell), \text{ for all } \ell \geq 2.$$

Hence

$$(3.2) \quad \bar{N}(\ell) = A(\ell) + \alpha(\ell)p(\ell) \quad \text{where } |\alpha(\ell)| \leq \sqrt{2} \text{ for all } \ell \geq 2.$$

For $\ell \geq 2$:

$$\bar{N}(\ell) = \sum_{(m,n) \in K(\ell)} 1$$

(an empty sum will be by definition equal to zero).

Therefore

$$\bar{N}(\ell) = \sum_{1 \leq d \leq \ell} \sum_{\substack{(m,n) \in K(\ell) \\ \{m,n\} = d}} 1 \quad (\ell \geq 2).$$

Then, since $\{n, m\} = d \Leftrightarrow \{\frac{n}{d}, \frac{m}{d}\} = 1$, it follows that there exists a bijective correspondence between the sets

$$\begin{aligned} B_1(d) &= \{(n, m) \in \tau(\ell) \mid \{n, m\} = d\} \text{ and} \\ B_2(d) &= \{(n', m') \mid (n', m') \in \tau(\ell/d), \{n', m'\} = 1\} \end{aligned}$$

where $(1 \leq d \leq \ell)$.

By definition, the number of elements of $B_2(d)$ is equal to $N(\ell/d)$. Hence,

$$\bar{N}(\ell) = \sum_{1 \leq d \leq \ell} N\left(\frac{\ell}{d}\right), \quad (\ell \geq 2).$$

Applying the Möbius inversion formula, we obtain

$$N(\ell) = \sum_{1 \leq d \leq \ell} \mu(d) \overline{N} \left(\frac{\ell}{d} \right), \quad (\ell \geq 2).$$

where μ is the Möbius function.

By (3.2), we have

$$N(\ell) = \sum_{1 \leq d \leq \ell} \mu(d) \left[\frac{A(\ell)}{d^2} + \ell p(1) \alpha \left(\frac{\ell}{d} \right) \left(\frac{1}{d} \right) \right].$$

Since $\alpha(\cdot)$ is bounded for all $\ell > 2$, and $|\mu(d)| \leq 1$, we have

$$-\sqrt{2} \sum_{1 \leq d \leq \ell} \frac{1}{d} \leq \sum_{1 \leq d \leq \ell} \frac{\alpha \left(\frac{\ell}{d} \right) \mu(d)}{d} \leq \sqrt{2} \sum_{1 \leq d \leq \ell} \frac{1}{d}$$

By Euler: $\gamma \leq \sum_1^\ell \frac{1}{d} - \log \ell \leq 1$, where $\gamma = 0.5770\dots$, is Euler's constant. Therefore

$$\sum_{1 \leq d \leq \ell} \frac{\alpha \left(\frac{\ell}{d} \right) \mu(d)}{d} = \beta(\ell) \log \ell$$

where β is a function such that $|\beta(\ell)| \leq \sqrt{2} \left(1 + \frac{1}{\log 2} \right) < 6$ for all $\ell \geq 2$.

On the other hand,

$$\sum_{1 \leq d \leq \ell} \frac{\mu(d)}{d^2} = (\zeta(2))^{-1} - \sum_{d=[\ell]+1}^{\infty} \frac{\mu(d)}{d^2} = \frac{6}{\pi^2} - \sum_{d=[\ell]+1}^{\infty} \frac{\mu(d)}{d^2}$$

and

$$\left| \sum_{d=[\ell]+1}^{\infty} \frac{\mu(d)}{d^2} \right| < \int_{[\ell]}^{\infty} \frac{du}{u^2} = \frac{1}{[\ell]}$$

(where $[\cdot]$ is the greatest-integer function).

Finally, since $A(\ell) = A(1)\ell^2 < \frac{1}{2}\ell^2$, and $p(1) < 2 + \sqrt{2}$ we have that

$$N(\ell) = \frac{6}{\pi^2} A_e(\tau(\ell) + \eta(\ell)\ell \log \ell)$$

where

$$|\eta(\ell)| \leq (2 + 2\sqrt{2}) \left(1 + \frac{1}{\log 2} \right) < 24.$$

□

Corollary 3.3. *The following estimates hold:*

$$\lim_{\ell \rightarrow \infty} \frac{N(\ell)}{A_e(\tau(\ell))} = \frac{6}{\pi^2}$$

and

$$\lim_{\ell \rightarrow \infty} \frac{N(\ell)}{\ell^2} = \frac{6A(1)}{\pi^2}$$

Remark. Let $\check{\tau}(\ell) := \{(u, v) \in \tau(\ell) | v < \ell\}$ denote $\tau(\ell)$ minus its base, and let $\check{N}(\ell)$ denote the number of lattice points with relatively prime coordinates contained in $\check{\tau}(\ell)$. Then

$$\check{N}(\ell) = N(\ell) + K(\ell)\ell, \quad \text{where } |K(\ell)| \leq 1.$$

Therefore

$$(3.4) \quad \begin{aligned} \check{N}(\ell) &= \frac{6}{\pi^2} A(\tau(\ell)) + \check{\eta}(\ell)\ell \log \ell, \quad \text{where} \\ |\check{\eta}(\ell)| &\leq 2 + (2 + 2\sqrt{2})\left(1 + \frac{1}{\log 2}\right) \quad \text{for all } \ell \geq 2 \end{aligned}$$

Let $\ell > 2$, $0 < \alpha_1 < \alpha_2 \leq 1$, $0 < \beta_1 < \beta_2$. Let $\Delta(\ell)$ be the trapezium in \mathbb{R}_+^2 defined as

$$\begin{aligned} \Delta(\ell) &= \{(u, v) \in \mathbb{R}_+^2 | \alpha_1 \leq u/v \leq \alpha_2, \beta_1 \ell \leq v \leq \beta_2 \ell\}, \text{ i.e.,} \\ \Delta(\ell) &= \tau(\beta_2 \ell) - \check{\tau}(\beta_1 \ell). \end{aligned}$$

Let $\hat{N}(\ell)$ be the number of lattice points with relatively prime coordinates contained in $\Delta(\ell)$. Then

$$\hat{N}(\ell) = N(\beta_2 \ell) - \check{N}(\beta_1 \ell).$$

Therefore, by Theorem (3.1) and (3.4) we have

Corollary 3.5. *The following equality holds*

$$\hat{N}(\ell) = \frac{6}{\pi^2} A_e(\Delta(\ell)) + \hat{\eta}(\ell)\ell \log \ell$$

where

$$|\hat{\eta}(\ell)| \leq 40[\beta_2 - \beta_1 + \beta_2 \log \beta_2 - \beta_1 \log \beta_1 + 1]$$

for all $\ell \geq \max\{2, 2\beta_1^{-1}, e^{\beta_1}\}$.

Corollary 3.6. *The following formula holds:*

$$\lim_{\ell \rightarrow \infty} \frac{\hat{N}(\ell)}{\ell^2} = \frac{6}{\pi^2} A_e(\Delta(1)).$$

The following lemma depends only on two properties: the infinitude of primes and the fact that $\varphi(p) = p - 1$ if p is a prime.

Lemma 3.7. *Keeping the notation of Theorem (3.1) we have:*

$$\overline{\lim}_{\ell \rightarrow \infty} \left(\left| \frac{N(\ell)}{A(\ell)} - \frac{6}{\pi^2} \right| \ell^{\frac{3}{2} - \epsilon} \right) = \infty,$$

for every ϵ such that $-\infty < \epsilon < \frac{1}{2}$.

Proof. Suppose the lemma is not true for some $\epsilon \in (-\infty, 1/2)$. Then there exists a bounded function $B_\epsilon(\ell)$, bounded for all $\ell > 2$, such that

$$(3.8) \quad \frac{N(\ell)}{A(\ell)} - \frac{6}{\pi^2} = B_\epsilon(\ell)\ell^{-\frac{3}{2} + \epsilon}, \quad (\ell > 0).$$

Define $H(\ell)$ by

$$H(\ell) = \frac{N(\ell)}{A(\ell)},$$

then

$$(3.9) \quad H(\ell + 1) = H(\ell) \frac{A(\ell)}{A(\ell + 1)} + \frac{\omega(\ell)}{A(\ell + 1)} = \left(\frac{\ell}{\ell + 1} \right)^2 H(\ell) + \frac{\omega(\ell)}{A(1)(\ell + 1)^2},$$

where $\omega(\ell)$ is the number of lattice points with relatively prime coordinates contained in $\tau(\ell + 1) - \tau(\ell)$ i.e.

$$\omega(\ell) = \{(a, b) \in \mathbb{Z}^+ \times \mathbb{Z}^+ | \{a, b\} = 1, (a, b) \in \tau(\ell + 1), b = [\ell + 1]\}.$$

If $[\ell + 1]$ is a prime, then $\omega(\ell) = \#\{a \in \mathbb{N} | \alpha_1 \leq a/[\ell + 1] \leq \alpha_2, a < [\ell + 1]\}$.

Now, $\tau(\ell + 1) - \tau(\ell)$ is a trapezium of unit height, with its bottom side missing and whose non parallel sides have positive slope greater than or equal to one (and whose parallel sides are also parallel to the horizontal axis). Therefore it must contain at least $\frac{(\alpha_2 - \alpha_1)(2\ell + 1)}{2} - 2$ lattice points and at most $\frac{(\alpha_2 - \alpha_1)(2\ell + 1)}{2} + 3$ such points.

Hence, if $[\ell + 1]$ is a prime, then

$$(3.10) \quad \omega(\ell) = \frac{(\alpha_2 - \alpha_1)(2\ell + 1)}{2} + \nu(\ell), \quad \text{where } |\nu(\ell)| \leq 3.$$

From (3.8) and (3.10) we obtain

$$\left[\frac{6}{\pi^2} + B_\epsilon(\ell) \ell^{-\frac{3}{2} + \epsilon} \right] \left[\frac{\ell}{\ell + 1} \right]^2 + \frac{\omega(\ell)}{A(1)(\ell + 1)^2} = \frac{6}{\pi^2} + B_\epsilon(\ell + 1)(\ell + 1)^{-\frac{3}{2} + \epsilon}$$

Hence

$$(3.11) \quad \begin{aligned} L(\ell) &:= \left[\frac{6}{\pi^2} \left[1 - \left(\frac{\ell}{\ell + 1} \right)^2 \right] - \frac{\omega(\ell)}{A(1)(\ell + 1)^2} \right] (\ell + 1)^{3/2 - \epsilon} \\ &= B_\epsilon(\ell) \left[\frac{\ell}{\ell + 1} \right]^{\frac{1}{2} + \epsilon} - B_\epsilon(\ell + 1) =: R(\ell) \end{aligned}$$

Now considerer formula (3.11) for all $\ell > 2$ such that $[\ell + 1]$ is a prime. Then, using (3.10) we have

$$L(\ell) = \left[\left(\frac{6}{\pi^2} - 1 \right) \left(\frac{2\ell + 1}{(\ell + 1)^2} \right) - \frac{\nu(\ell)}{A(1)(\ell + 1)^2} \right] (\ell + 1)^{3/2 - \epsilon} \quad ([\ell + 1] \text{ a prime})$$

(recallig that $A(1) = (\alpha_2 - \alpha_1)/2$). But now we arrive to a contradiction since under the hypothesis, $R(\ell)$ is bounded for all $\ell > 2$ whereas $L(\ell)$ tends to infinity when l tends to infinity by a sequence $\{\ell_n\}$ such that $[\ell_n + 1]$ is prime. \square

Remark 3.12. The fact that the set of all $\ell > 2$ for which $[\ell + 1]$ is a prime, is infinite, is all that we used. Hence, it does not depend on the triangle.

Remark 3.13. When ϵ above is very close to $1/2$, then $\theta(\ell) := \left[\frac{N(\ell)}{A(\ell)} - \frac{6}{\pi^2} \right] \ell^{3/2-\epsilon}$ oscillates and becomes unbounded extremely slowly. Also it follows that $\theta_{\delta,c}(\ell) := \left[\frac{N(\ell)}{A(\ell)} - c \right] \ell^{\delta+3/2}$ is $O(1)$ as $\ell \rightarrow \infty$ if and only if $c = \frac{6}{\pi^2}$ and $\delta < -\frac{1}{2}$. When α_1 and α_2 are rational and we let ℓ go to infinity through natural numbers then $N(\ell)/A(\ell)$ are (not very good) rational approximations of $\frac{6}{\pi^2}$.

In the context of Corollary 3.5, let $\overset{\circ}{\Delta}(\ell)$ denote the trapezium $\Delta(\ell)$ minus its open base:

$$\overset{\circ}{\Delta}(\ell) = \{(u, v) \in \mathbb{R}_+^2 \mid 0 < \alpha_1 \leq u/v \leq \alpha_2 \leq 1, \beta_1 \ell < v \leq \beta_2 \ell\}.$$

Then if $\overset{\bullet}{N}(\ell)$ denotes the number of lattice points with relatively prime coordinates contained in $\overset{\circ}{\Delta}(\ell)$, we have

$$(3.14) \quad \overset{\bullet}{N}(\ell) = \hat{N}(\ell) + \xi(\ell)\beta_1\ell, \quad \text{where } -1 \leq \xi(\ell) \leq 0, \text{ for all } \ell > 2.$$

Corollary 3.15. *For every $\epsilon > 0$ such that $-\infty < \epsilon < 1/2$ we have*

$$\overline{\lim}_{\ell \rightarrow \infty} \left(\left| \frac{\hat{N}(\ell)}{A_e(\Delta(\ell))} - \frac{6}{\pi^2} \right| \ell^{3/2-\epsilon} \right) = \infty.$$

Proof. Suppose the corollary is false for some ϵ , $\epsilon \in (-\infty, 1/2)$. Then, just as in Lemma (3.7), there exists a function $B_\epsilon(\ell)$ bounded for all $\ell > 2$ such that

$$\frac{\hat{N}(\ell)}{A_e(\Delta(\ell))} - \frac{6}{\pi^2} = B_\epsilon(\ell)\ell^{-3/2+\epsilon}.$$

Then by (3.14), we have

$$-\ell^{3/2-\epsilon} \left| \frac{\hat{N}(\ell)}{A_e(\Delta(\ell))} - \frac{6}{\pi^2} \right| \leq \ell^{3/2+\epsilon} \left| \frac{\overset{\bullet}{N}(\ell)}{A_e(\Delta(\ell))} - \frac{6}{\pi^2} \right| \leq \ell^{3/2-\epsilon} \left| \frac{\hat{N}(\ell)}{A_e(\Delta(\ell))} - \frac{6}{\pi^2} \right|.$$

Hence, we also have

$$\overline{\lim}_{\ell \rightarrow \infty} \ell^{3/2+\epsilon} \left| \frac{\overset{\bullet}{N}(\ell)}{A_e(\Delta(\ell))} - \frac{6}{\pi^2} \right| < \infty \quad (\ell > 2, -\infty < \epsilon < 1/2)$$

Therefore, under the hypothesis, we conclude the existence of a function $\overset{\bullet}{B}_\epsilon(\ell)$ whose absolute value is bounded by some positive constant for all $\ell > 2$, and such that

$$\overset{\bullet}{N}(\ell) = \frac{6}{\pi^2} A_e(\Delta(\ell)) + A_e(\Delta(\ell)) \overset{\bullet}{B}_\epsilon(\ell) \ell^{-3/2+\epsilon} \quad (\ell > 2, -\infty < \epsilon < 1/2)$$

$$\overset{\bullet}{B}_\epsilon(\ell) = -\frac{6}{\pi^2} \ell^{3/2-\epsilon} \quad \text{if } \ell < \beta_2^{-1}.$$

Now, let $\delta = \beta_1\beta_2^{-1}$. Then

$$\begin{aligned}
 N(\beta_2\ell) &= \sum_{n=0}^{\infty} \dot{N}(\delta^n\ell) \\
 &= \sum_{n=0}^{\infty} \frac{6}{\pi^2} A_e(\Delta(\delta^n\ell)) + A_e(\Delta(\delta^n\ell)) \dot{B}(\delta^n\ell)(\delta^n\ell)^{-3/2+\epsilon} \\
 &= \frac{6}{\pi^2} A_e(\tau(\beta_2\ell)) + \left(\sum_{n=0}^{\infty} A_e(\Delta(\delta^n\ell)) \dot{B}(\delta^n\ell)(\delta^n\ell)^{-3/2+\epsilon} \right) \\
 &\quad + \sum_{n=m}^{\infty} \left(-\frac{6}{\pi^2} \right) A_e(\Delta(\delta^n\ell))
 \end{aligned}$$

where $m = \min\{n \in \mathbb{N} \mid \ell < \delta^{-n}\beta_2^{-1}\}$ and where $N(\cdot)$, $\tau(\cdot)$ are exactly as in Theorem 3.1. Therefore, we have

$$\begin{aligned}
 (3.16) \quad N(\beta_2\ell) &= \frac{6}{\pi^2} A_e(\tau(\beta_2\ell)) + \left\{ \sum_{n=0}^{\infty} A_e(\Delta(\delta^n\ell)) \dot{B}(\delta^n\ell)(\delta^n\ell)^{-3/2+\epsilon} \right\} \\
 &\quad - \frac{6}{\pi^2} A_e(\tau(\delta^{m+1}(\beta_2\ell))).
 \end{aligned}$$

But (3.16) implies that,

$$N(\ell) = \frac{6}{\pi^2} A_e(\tau(\ell)) + A_e(\tau(\ell)) \bar{B}_\epsilon(\ell) \ell^{-3/2+\epsilon}, \quad \infty < \epsilon < 1/2,$$

where $\bar{B}_\epsilon(\ell)$ is bounded for all $\ell > 2$. But this contradicts Lemma (3.7), therefore, Corollary 3.6 must be true. \square

Let us recall the functions T_t , Ψ and μ_t given by formulas (2.13), (2.15) and (2.17) and connected by formula (2.18): $\Psi \circ \mu_t = T_t \circ \Psi$.

Let $C \subset M$ by any adapted box whose base $\beta(C)$ corresponds to the rectangle

$$Q \subset \mathbb{H}, \quad Q := \{(x, y) \mid \alpha_1 \leq x \leq \alpha_2 \quad \beta_1 \leq y \leq \beta_2\}$$

where $0 < \alpha_1 < \alpha_2 \leq 1$ and $0 < \beta_1 < \beta_2$. Let $\delta(1)$ be the trapezium in \mathbb{R}_+^2 such that $\Psi(\delta(1)) = Q$. Then

$$\Psi(\Delta(e^{t/2})) = Q_t = T_t(\Psi(\Delta(1))), \quad (t \in \mathbb{R})$$

where Q_t is the rectangle which corresponds to the adapted box $g_{-t}(C)$. As before, let $n(t) = \#\{\gamma_0 \cap g_{-t}(\beta(C))\}$. Then, (by (1.1), (2.14), (2.19)), we have

$$n(t) = \hat{N}(e^{t/2}).$$

By Corollary 3.5 we have that the function $n(t)$ must be of the form:

$$(3.17) \quad n(t) = \frac{6}{\pi^2} A_e(\Delta(e^{\frac{t}{2}})) + \hat{\eta}(e^{\frac{t}{2}}) \frac{te^{\frac{t}{2}}}{2},$$

where $\hat{\eta}$ is a function bounded as follows:

$$|\eta(e^{\frac{t}{2}})| \leq 40(\beta_1^{-1/2} + \beta_2^{-1/2} + \frac{1}{2}(\beta_2^{-1/2} \log \beta_2 - \beta_1^{-1/2} \log \beta_1 + 1))$$

for all $t \geq 2\max\{\log 2, \log 2 + \frac{1}{2} \log \beta_2, \beta_2^{-\frac{1}{2}}\}$.

From (3.17) we obtain

$$n(t) = \frac{3}{\pi^2} A_h(g_{-t}(\beta(C))) + \hat{\eta}(e^{\frac{t}{2}}) \frac{te^{\frac{t}{2}}}{2}.$$

And hence we obtain:

$$n(t) = \frac{3}{\pi^2} A_h(\beta(C)) e^t + \hat{\eta}(e^{\frac{t}{2}}) \frac{te^{\frac{t}{2}}}{2}.$$

From Corollary (3.15) we obtain

$$\overline{\lim}_{t \rightarrow \infty} \left[\left(\frac{n(t)e^{-t}}{A_h(\beta(C))} - \frac{3}{\pi^2} \right) e^{\alpha t} \right] = +\infty$$

for every $\alpha > 1/2$.

Changing the parameter: $y = e^{-t}$ and denoting as usual by m_y the horocycle measure concentrated in the unstable horocycle periodic orbit as period $1/y$ ($y > 0$) we obtain using formula (1.1)

Theorem 3.18. *Let $C \subset M$ be any adapted box. Then*

$$m_y(C) = \overline{m}(C) + K_C(y) y^{1/2} \log y$$

where $|K_C(y)|$ is bounded by some positive constant for all $0 < y \leq 1/2$. Furthermore, this positive constant can be chosen to be the same for every adapted box contained in C .

(Compare with theorem 1.4)

Corollary 3.19. *The following holds:*

$$\lim_{y \rightarrow 0} m_y(C) = \overline{m}(C).$$

We have proved everything in Theorem (3.18). The fact there exists a constant k such that $|K_C(y)| \leq k$ for all $0 < y \leq 1/2$ and every box $C' \subset C$ follows from (3.17).

Theorem 3.20. *Let C be any adapted box. Then*

$$(3.21) \quad \overline{\lim}_{y \rightarrow \infty} [|m_y(C) - \overline{m}_y(C)| y^\alpha] = +\infty$$

for all $\alpha > 1/2$.

Theorem 3.22. *Let $f: M \rightarrow \mathbb{R}$ be any continuous function with compact support. Then, there exists a positive constant $K(f)$, depending only of f , such that*

$$(3.23) \quad |m_y(f) - \overline{m}(f)| \leq K(f) y^{1/2} |\log y|, \quad (0 < y \leq 1/2).$$

Furthermore, if $\alpha > 1/2$, then

$$(3.24) \quad \overline{\lim}_{y \rightarrow 0} [|m_y(\chi_U) - \overline{m}(\chi_U)| y^{-\alpha}] = \infty.$$

Proof. (3.24) is a direct consequence of (3.21). For (3.23) one proceeds as follows: Let $\mathcal{B} = \text{supp}(f)$. Let $V_i = \{C_{1,i}, C_{2,i}, \dots, C_{n_i,i}\}$ $i = 1, 2, \dots$ be a sequence of finite coverings of \mathcal{B} by adapted boxes. Let $F_i = \{g_1^i, \dots, g_{n_i}^i\}$ be a smooth partition of unity subordinated to V_i ($i = 1, 2, \dots$). For $i > 1$ suppose that the maximum diameter of the boxes in V_i is less than a Lebesgue number for the covering V_{i-1} . If we consider $\{g_1^i, \dots, g_{n_i}^i\}$ we see that we can uniformly approximate f by a finite sum of functions which are constant on a box and zero outside that box. The rest follows from Theorem (3.18). \square

4. APPENDIX A

The Ranking-Selberg Method and the Mellin transform of \bar{m}_y .

In all that follows we will borrow from [19] and [16].

Let $f: M \rightarrow \mathbb{R}$ be any C^∞ function with compact support. Consider for $s \in \mathbb{C}$ with $\Re(s) > 1$ the Mellin-type transform

$$\langle E(s), f \rangle := G_f(s) := \int_0^\infty m_y(f) y^{s-1} \frac{dy}{y}.$$

We may think of f as a function $f: T_1\mathbb{H} \rightarrow \mathbb{R}$ which is Γ -invariant ($\Gamma = \text{PSL}(2, \mathbb{Z})$). Then

$$\langle m_y, f \rangle := m_y(f) = \int_0^1 f(x, y, 0) dx$$

where x, y and θ are the parameters of $\text{SL}(2, \mathbb{R})$ described before.

Let $K_f = \sup\{\mathfrak{F}(s) | (z, \theta) \in \text{supp}(f)\}$. Then if $\Re(s) > 1$:

$$(4.1) \quad |G_f(s)| \leq \|f\|_\infty \frac{(K_f)^{\sigma-1}}{\sigma-1} \sigma = \mathfrak{R}(s).$$

Therefore, we see that

- (i) The integral defining $G_f(\cdot)$ converges absolutely and uniformly in $\Re(s) > 1 + \epsilon$. Therefore $G_f(\cdot)$ is holomorphic in $\Re(s) > 1$.
- (ii) Because of inequality (4.1) it follows that

$$E(\cdot): \{\Re(s) > 1\} \rightarrow [C_c^\infty]^* = \mathcal{D}(M)$$

defines a weakly holomorphic function with values in the distribution space, $\mathcal{D}(M)$, of M . In fact, (4.1) implies that for all s_0 , with $\Re(s_0) > 1$, $E(s_0)$ is complex valued infinite measure concentrated in $P(L^+)$ and invariant under h_t^+ . Where h_t^+ acts on distributions \mathcal{S} as follows:

$$\langle h_t^+ \mathcal{S}, f \rangle = \langle \mathcal{S}, f \circ h_{-t}^+ \rangle, \quad f \in C_c^\infty(M), t \in \mathbb{R}.$$

- (iii) For every $f \in C_c^\infty(M)$, $G_g(\cdot)$ can be extended as a meromorphic function to all of \mathbb{C} with no singularities in $\Re(s) > 1/2$ except for a simple pole at $s = 1$ with residue

$$\text{Res}(G_f(s))|_{s=1} = \bar{m}(f).$$

(iv) The growth on vertical lines $t \mapsto \sigma + it$ is controlled by the growth of

$$\phi(s) = \frac{\pi^{1/2}\Gamma(s-1/2)\zeta(2s-1)}{\Gamma(s)\zeta(2s)}.$$

(v) $E(\cdot): \mathbb{C} \rightarrow \mathcal{D}(M) \cup \infty$ has the property that $E(s)$ is a distribution of finite order (s not a pole); $E(S)$ satisfies the following functional equation:

$$E(s) = \mathcal{H}(s, \cdot) * E(1-s)$$

where $*$ denotes convolution and

$$\mathcal{H}(s, \theta) = \left[\frac{\Gamma(s)}{\pi^{1/2}\Gamma(s-1/2)} (\sin \theta/2)^{2s-2} \right] \phi(s) = (\sin \theta/2)^{2s-2} \frac{\zeta(2s-1)}{\zeta(2s)}$$

and $\mathcal{H}(s, \cdot)$ acts on 2π -periodic vector functions by convolution in the θ variable.

(vi) Let $\mathfrak{a} = \sup\{\Re(\rho); \zeta(\rho) = 0\}$. Then, by Mellin inversion formula, we have for every $f \in C_c^\infty(M)$:

$$m_y(f) = \frac{1}{2\pi i} \int_{-\frac{1}{2}-i\infty}^{-\frac{1}{2}+i\infty} G_f(s+1)y^{-s} ds$$

(the validity of this inversion is shown in [16]).

Changing variables and classical growth estimates of $\zeta(s)$, $\Gamma(s)$ (Titchmarsh formulae (14.25) (14.2.6) p.283 [17]) we have the validity of the following inversion:

$$(4.2) \quad m_y(f) = \frac{1}{4\pi i} \int_{\alpha-i\infty}^{\alpha+\infty} G_f\left(\frac{s}{2}\right) y^{1-\frac{s}{2}}, \quad \text{For } \alpha > \mathfrak{a}.$$

The right-hand side of (4.2) is a superposition of functions which are $O(1 - \frac{\alpha}{2} - \epsilon)$ for all $\epsilon > 0$ ($y \rightarrow 0$) hence, $m_y(f)$ has the same order for all $f \in C_c^\infty(M)$. This is the connection with the Riemann Hypothesis found by Zagier. To prove the Riemann Hypothesis it is enough to find a C^2 function, f , with compact support in M such that the error term $|m_y(f) - \overline{m}_y(f)|$ can be made $o(y^{3/4-\epsilon})$ for all $\epsilon > 0$ and whose Mellin transform has no zeroes on the critical strip.

Eisenstein Series. Let $C^\downarrow(S(\Gamma))$ denote the space of functions which decay very rapidly as the argument of the function approaches the cusp. Namely: the space of functions $f: \mathbb{H} \rightarrow \mathbb{C}$ which are Γ -invariant and such that $f(x+iy) = O(y^{-N})$ for all N . Then, since $f(x+iy)$ is periodic of period one in the x -variable we may develop it into a Fourier series

$$f(x+iy) = \sum_{n \in \mathbb{Z}} \hat{f}_n(y) e^{2\pi i n x}, \quad (y > 0).$$

Let $C(f, y) = \int_0^1 f(x+iy) dx$ denote the constant term of its Fourier expansion:

$$C(f, y) = \hat{f}_0(y).$$

Let $\mathcal{M}(f, s)$ be the Mellin transform of $C(f, y)$:

$$\mathcal{M}(f, s) = \int_0^\infty C(f, y) y^{s-1} \frac{dy}{y}, \quad (\Re(s) > 1).$$

Using the fact f is Γ -invariant and the fact that for $\gamma \in \Gamma$ we go from a fundamental domain to the standard domain, we have:

$$\begin{aligned} \mathcal{M}(f, s) &= \int_0^\infty \int_0^1 C(f, y) y^{s-1} \frac{dy}{y} = \int_0^\infty \int_0^1 f(x + iy) y^s \frac{dx dy}{y^2} \\ &= \int_{\mathbb{H}/\Gamma} f(x) E(z, s) dz = \int_{S(\Gamma)} f(x) E(z, s) dz \quad (dz = \frac{dx dy}{y^2}). \end{aligned}$$

Hence

$$\mathcal{M}(f, s) = \int_{S(\Gamma)} f(x) E(z, s) dz.$$

With this formula we see that $\mathcal{M}(f, s)$ enjoys the same properties of $E(z, s)$:

- (i) $\mathcal{M}(f, s)$ has a meromorphic continuation to all of \mathbb{C} . It has a simple pole at $s = 1$.
- (ii) $\text{Res}_{s=1} \mathcal{M}(f, s) = \frac{3}{\pi} \int_{S(\Gamma)} f(u) du$.
- (iii) $M^*(f, s) := \pi^{-s} \Gamma(s) \zeta(2s) \mathcal{M}(f, s)$ is regular in $\mathbb{C} - \{0, 1\}$ and it satisfies the functional equation

$$\mathcal{M}^*(f, s) = \mathcal{M}^*(f, 1 - s).$$

$E(z, s)$ is an Eisenstein Series:

$$E(z, s) = \sum_{\gamma \in \Gamma_\infty/\Gamma} \mathfrak{F}(\gamma z)^s = \frac{1}{2} \sum_{\substack{c, d \in \mathbb{Z} \\ \{c, d\} = 1}} \frac{y^s}{|cz + d|^{2s}}$$

5. APPENDIX B

Discrete measures and the Riemann-Hypothesis. We refer to [18] for this appendix. Many of the facts of this paper can be reduced to the study of discrete measures in the multiplicative group of the positive reals. Let $\mathbb{R}^\bullet = \{y \in \mathbb{R} : t > 0\}$. Let $f : \mathbb{N} \rightarrow \mathbb{C}$ be any arithmetic function. For $y \in \mathbb{R}^\bullet$ consider the distribution $\nu_y : C_0^\infty(\mathbb{R}^\bullet) \rightarrow \mathbb{C}$, where $C_0^\infty(\mathbb{R}^\bullet)$ is the space of smooth functions with compact support, defined by the formula:

$$\nu_{y,f} = \sum_{n \in \mathbb{N}} f(n) \delta_{ny},$$

where δ_x is the Dirac measure at the point $x \in \mathbb{R}^\bullet$, *i.e.*,

$$\nu_{y,f}(g) = \sum_{n \in \mathbb{N}} f(n) g(ny), \quad g \in C_0^\infty(\mathbb{R}^\bullet)$$

The Mellin transform of $\nu_{y,f}(g)$ as a function of $y \in \mathbb{R}^\bullet$

$$M_g(s) = \int_0^\infty y^{s-1} \nu_{y,f}(g) dy$$

can be used to study the behavior of $\nu_{y,f}(f)$ as $y \rightarrow 0$. This is of course related to arithmetic since the Mellin transform of ν_y involves the Mellin transform of f and the Dirichlet series

$$\sum_{n \in \mathbb{N}} \frac{f(n)}{n^s}$$

For instance in [18] there is the following:

Theorem 5.1. *Let f above be Euler totient function $\varphi(n)$ that counts the number of integers lesser or equal to n which are relatively prime to the integer n . Then,*

(1) *For all $g \in C_0^\infty(\mathbb{R}^\bullet)$*

$$y^2 \nu_{y,\varphi}(g) = \int_0^\infty \frac{6}{\pi^2} u g(u) du + o(y) \quad \text{as } y \rightarrow 0$$

(2) *The Riemann hypothesis is true if and only if for all $g \in C_0^\infty(\mathbb{R}^\bullet)$*

$$y^2 \nu_{y,\varphi}(g) = \int_0^\infty \frac{6}{\pi^2} u g(u) du + o(y^{\frac{3}{2}-\epsilon}) \quad \text{as } y \rightarrow 0 \quad \forall \epsilon > 0$$

Remark. The author has found an interesting connection with Hurwitz zeta function by considering horocycle measures concentrated on equally spaced closed horocycles approaching the cusp. Also one could give a geometric proof of the theorem of Franel-Landau.

ACKNOWLEDGEMENTS

I would like to thank S. G. Dani, E. Ghys, S. Lopez de Medrano, C. McMullen, B. Randol, D. Sullivan. Finally I would like to thank Dalid Rito Rodríguez, Antonia Sánchez Godinez y José Juan Zacarías for having typed the present version.

REFERENCES

- [1] D. V. Anosov, *Pro. Steklov Inst. Math.* 90 (1967).
- [2] T. Apostol, *Introduction to the theory of numbers*, Springer-Verlag, Berlin-Heidelberg-New York, 1979.
- [3] K. Chandrasekharan, *Introduction to Analytic number theory*, Springer-Verlag, 1968.
- [4] S. G. Dani, *Invariant measures of horospherical flows on noncompact homogeneous spaces*, *Invent. Math.* **47** (1978), 101–138.
- [5] H. M. Edwards, *Riemann's zeta function*, Academic Press, New York, London, 1974.
- [6] J. Franel, *Les Suites de Farey et le problème des nombres premiers*, *Göttinger Nachrichten* (1924), 198–201.
- [7] H. Furstenberg, *The unique ergodicity of the horocycle flow*, *Recent Advances in Topological Dynamics* (A. Beck, ed.), Springer-Verlag, Berlin, Heidelberg, New York, 1972, pp. 95–115.
- [8] E. Ghys, *Actions localment libres du groupe affine*, *Invent. Math.* **82** (1985), 479–526.
- [9] G. A. Hedlund, *Fuchsian groups and transitive horocycles*, *Duke Math. J.* **2** (1936), 530–542.
- [10] G. H. Hardy and E. M. Wright, *An introduction to the theory of numbers*, Oxford Univ. Press London, 1975.
- [11] S. Lang, *SL₂(R)*, Addison-Wesley, Reading, Mass., 1975.
- [12] E. Landau, *Bemerkung zu der vorstehenden Arbeit von Herrn Franel*, *Göttinger Nachrichten* (1924), 202–206.
- [13] G. A. Margulis, *On the action of unipotent groups in the space of lattices*, *Proceedings of the summer School on group representations*, Bolyai Janos. Math. Soc., Budapest, 1971, pp. 365–370.
- [14] J.F. Plante, *Anosov flows, transversely affine foliations and a conjecture of Verjovskiy*, *Jour. of Lond. Math. Soc.* **23** (1981).
- [15] M. S. Raghunathan, *Discrete subgroups of Lie groups*, Springer-Verlag, Berlin, Heidelberg, New York, 1972.

- [16] P. Sarnak, *Asymptotic behavior of periodic orbits of the horocycle flow and Eisenstein Series*, Comm. on Pure and Applied Math. **34** (1981), 719–731.
- [17] E. C. Titchmarsh, *The theory of the Riemann zeta-function*, Oxford Univ. Press, London, 1988.
- [18] A. Verjovsky, *Discrete measures and the Riemann hypothesis*. Workshop on Geometry and Topology (Hanoi, 1993). Kodai Math. J. 17 (1994), no. 3, 596–608
- [19] D. Zagier, *Eisenstein Series and the Riemann zeta function*, Automorphic forms, Representation theory and Arithmetic, Tata Institute of Fundamental Research, Bombay, 1979, Springer-Verlag, Berlin-Heidelberg-New York, 1981, pp. 275–301.