

Achieving Starvation-Freedom in Multi-Version Transactional Memory Systems *

Ved Prakash Chaudhary ^{†1}, Chirag Juyal¹, Sandeep Kulkarni², Sweta Kumari¹, and Sathya Peri^{‡1}

¹Department of Computer Science & Engineering, IIT Hyderabad, India ,
{cs14mtech11019, cs17mtech11014, cs15resch01004,
sathya.p}@iith.ac.in

²Department of Computer Science, Michigan State University, USA,
sandeep@cse.msu.edu

Abstract

Software Transactional Memory systems (STMs) have garnered significant interest as an elegant alternative for addressing synchronization and concurrency issues with multi-threaded programming in multi-core systems. For STMs to be efficient, they must guarantee some progress properties. This work explores the notion of one of the progress property, i.e., *starvation-freedom*, in STMs. An STM system is said to be starvation-free if every thread invoking a transaction gets the opportunity to take a step (due to the presence of a fair scheduler) such that the transaction eventually commits.

A few *starvation-free* algorithms have been proposed in the literature in context of single-version STMs. These algorithms are priority based i.e. if two transactions are in conflict, then the transaction with lower priority will abort. A transaction running for a long time will eventually have the highest priority and hence commit. But the drawback with this approach is that if a set of high-priority transactions become slow, then they can cause several other transactions to abort. So, we propose multi-version *starvation-free* STM system which addresses this issue.

Multi-version STMs maintain multiple-versions for each transactional object. By storing multiple versions, these systems can achieve greater concurrency. In this paper, we propose multi-version *starvation-free* STM, *KSFTM*, which as the name suggests achieves starvation-freedom while storing *K-versions* of each t-object. Here *K* is an input parameter fixed by the application programmer depending on the requirement. Our algorithm is dynamic which can support different values of *K* ranging from one to infinity. If *K* is infinite, then there is no limit on the number of versions. But a separate garbage-collection mechanism is required to collect unwanted versions. On the other hand, when *K* is one, it becomes the same as a single-version *starvation-free* STM system. We prove the correctness and *starvation-freedom* property of the *KSFTM* algorithm.

To the best of our knowledge, this is the first multi-version STM system that satisfies *starvation-freedom*. We implement *KSFTM* and compare its performance with single-version *starvation-free* STM system (*SV-SFTM*) which works on the priority principle. Our experiments show that *KSFTM* gives an average speedup on the worst-case time to commit of a transaction by a factor of 1.22, 1.89, 23.26 and 13.12 times over *PKTO*, *SV-SFTM*, NOrec STM and ESTM respectively for counter application. *KSFTM* performs 1.5 and 1.44 times better than *PKTO* and *SV-SFTM* but 1.09 times worse than NOrec for low contention KMEANS application of STAMP benchmark whereas *KSFTM* performs 1.14, 1.4 and 2.63 times better than *PKTO*, *SV-SFTM* and NOrec for LABYRINTH application of STAMP benchmark which has high contention with long-running transactions.

1 Introduction

STMs [13, 25] are a convenient programming interface for a programmer to access shared memory without worrying about consistency issues. STMs often use an optimistic approach for concurrent execution of *transactions*

*A preliminary version of this work was accepted in AADDA 2017 as **work in progress**.

[†]A part of this work was submitted towards the fulfillment of M.Tech thesis requirement by the author.

[‡]Author sequence follows a lexical order of last names.

(a piece of code invoked by a thread). In optimistic execution, each transaction reads from the shared memory, but all write updates are performed on local memory. On completion, the STM system *validates* the reads and writes of the transaction. If any inconsistency is found, the transaction is *aborted*, and its local writes are discarded. Otherwise, the transaction is committed, and its local writes are transferred to the shared memory. A transaction that has begun but has not yet committed/aborted is referred to as *live*.

A typical STM is a library which exports the following methods: *stm-begin* which begins a transaction, *stm-read* which reads a *transactional object* or *t-object*, *stm-write* which writes to a *t-object*, *stm-tryC* which tries to commit the transaction. Typical code for using STMs is as shown in Algorithm 1 which shows how an insert of a concurrent linked-list library is implemented using STMs.

Correctness: Several *correctness-criteria* have been proposed for STMs such as opacity [11], local opacity [18, 19]. All these *correctness-criteria* require that all the transactions including aborted ones appear to execute sequentially in an order that agrees with the order of non-overlapping transactions. Unlike the correctness-criteria for traditional databases, such as serializability, strict-serializability [22], the correctness-criteria for STMs ensure that even aborted transactions read correct values. This ensures that programmers do not see any undesirable side-effects due to the reads by transaction that get aborted later such as divide-by-zero, infinite-loops, crashes etc. in the application due to concurrent executions. This additional requirement on aborted transactions is a fundamental requirement of STMs which differentiates STMs from databases as observed by Guerraoui & Kapalka [11]. Thus in this paper, we focus on optimistic executions with the *correctness-criterion* being *local opacity* [19].

Starvation Freedom: In the execution shown in Algorithm 1, there is a possibility that the transaction which a thread tries to execute gets aborted again and again. Every time, it executes the transaction, say T_i , T_i conflicts with some other transaction and hence gets aborted. In other words, the thread is effectively starving because it is not able to commit T_i successfully.

A well known blocking progress condition associated with concurrent programming is starvation-freedom [15, chap 2], [14]. In the context of STMs, starvation-freedom ensures that every aborted transaction that is retried infinitely often eventually commits. It can be defined as: an STM system is said to be *starvation-free* if a thread invoking a transaction T_i gets the opportunity to retry T_i on every abort (due to the presence of a fair underlying scheduler with bounded termination) and T_i is not *parasitic*, i.e., T_i will try to commit given a chance then T_i will eventually commit. Parasitic transactions [4] will not commit even when given a chance to commit possibly because they are caught in an infinite loop or some other error.

Algorithm 1 *Insert(LL, e)*: Invoked by a thread to insert an element e into a linked-list LL . This method is implemented using transactions.

```

1: retry = 0;
2: while (true) do
3:   id = stm-begin (retry);
4:   ...
5:   ...
6:   v = stm-read(id, x); /* reads the value of x as v */
7:   ...
8:   ...
9:   stm-write(id, x, v'); /* writes a value v' to x */
10:  ...
11:  ...
12:  ret = stm-tryC(id); /* stm-tryC can return commit or abort */
13:  if (ret == commit) then
14:    break;
15:  else
16:    retry++;
17:  end if
18: end while

```

Wait-freedom is another interesting progress condition for STMs in which every transaction commits regardless of the nature of concurrent transactions and the underlying scheduler [14]. But it was shown by Guerraoui and Kapalka [4] that it is not possible to achieve *wait-freedom* in dynamic STMs in which data sets of transactions are not known in advance. So in this paper, we explore the weaker progress condition of *starvation-freedom* for transactional memories while assuming that the data sets of the transactions are *not* known in advance.

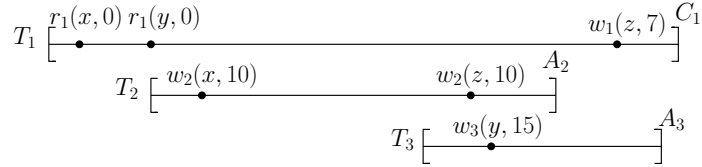

Figure 1: Limitation of Single-version Starvation Free Algorithm

Related work on the starvation-free STMs: Starvation-freedom in STMs has been explored by a few researchers in literature such as Gramoli et al. [9], Waliullah and Stenstrom [27], Spear et al. [26]. Most of these systems work by assigning priorities to transactions. In case of a conflict between two transactions, the transaction with lower priority is aborted. They ensure that every aborted transaction, on being retried a sufficient number of times, will eventually have the highest priority and hence will commit. We denote such an algorithm as *single-version starvation-free STM* or *SV-SFTM*.

Although *SV-SFTM* guarantees starvation-freedom, it can still abort many transactions spuriously. Consider the case where a transaction T_i has the highest priority. Hence, as per *SV-SFTM*, T_i cannot be aborted. But if it is slow (for some reason), then it can cause several other conflicting transactions to abort and hence, bring down the efficiency and progress of the entire system.

Fig 1 illustrates this problem. Consider the execution: $r_1(x, 0)r_1(y, 0)w_2(x, 10)w_2(z, 10)w_3(y, 15)w_1(z, 7)$. It has three transactions T_1 , T_2 and T_3 . Let T_1 has the highest priority. After reading y , suppose T_1 becomes slow. Next T_2 and T_3 want to write to x, z and y respectively and *commit*. But T_2 and T_3 's write operations are in conflict with T_1 's read operations. Since T_1 has higher priority and has not committed yet, T_2 and T_3 have to *abort*. If these transactions are retried and again conflict with T_1 (while it is still live), they will have to *abort* again. Thus, any transaction with the priority lower than T_1 and conflicts with it has to abort. It is as if T_1 has locked the t-objects x, y and does not allow any other transaction, write to these t-objects and to *commit*.

Multi-version starvation-free STM: A key limitation of single-version STMs is limited concurrency. As shown above, it is possible that one long transaction conflicts with several transactions causing them to abort. This limitation can be overcome by using multi-version STMs where we store multiple versions of the data item (either unbounded versions with garbage collection, or bounded versions where the oldest version is replaced when the number of versions exceeds the bound).

Several multi-version STMs have been proposed in the literature [17, 20, 8, 23] that provide increased concurrency. But none of them provide starvation-freedom. Furthermore, achieving starvation-freedom while using only bounded versions is especially challenging given that a transaction may rely on the oldest version that is removed. In that case, it would be necessary to abort that transaction, making it harder to achieve starvation-freedom.

A typical code using STMs is as shown in Algorithm 1. It shows the overview of a concurrent *insert* method which inserts an element e into a linked-list LL . It consists of a loop where the thread creates a transaction. This transaction executes the code to insert an element e in a linked-list LL using *stm-read* and *stm-write* operations. (The result of *stm-write* operation are stored locally.) At the end of the transaction, the thread calls *stm-tryC*. At this point, the STM checks if the given transaction can be *committed* while satisfying the required safety properties (e.g., serializability [22], opacity [11]). If yes, then the transaction is *committed*. At this time, any updates done by the transaction are reflected in the shared memory. Otherwise, it is aborted. In this case, all the updates made by the transaction are discarded. If the given transaction is aborted, then the invoking thread may retry that transaction again like Line 16 in Algorithm 1.

The advantage of multi-version STMs, is that they allow greater concurrency by allowing more transactions to commit. Consider the execution shown in Fig 1. Suppose this execution used multiple versions for each t-object. Then it is possible for all the three transactions to commit. Transactions T_2 and T_3 create a new version corresponding to each t-object x, z and y and return commit. Since multiple versions are being used, T_1 need not abort as well. T_1 reads the initial value of z , and returns commit. So, by maintaining multiple versions all the transactions T_1, T_2 , and T_3 can commit with equivalent serial history as $T_1T_2T_3$ or $T_1T_3T_2$. Thus multiple versions can help with starvation-freedom without sacrificing on concurrency. This motivated us to develop a multi-version starvation-free STM system.

Although multi-version STMs provide greater concurrency, they suffer from the cost of garbage collection. One way to avoid this is to use bounded-multi-version STMs, where the number of versions is bounded to be at most K . Thus, when $(K + 1)^{th}$ version is created, the oldest version is removed. Bounding the number of versions can hinder with starvation freedom: a transaction needing to read a version that is currently removed must be aborted.

This paper addresses this gap by developing a starvation-free algorithm for bounded MVSTMs. Our approach is different from the approach used in *SV-SFTM* to provide starvation-freedom in single version STMs (the policy of aborting lower priority transactions in case of conflict) as it does not work for MVSTMs. As part of the derivation of our final starvation-free algorithm, we consider an algorithm (*PKTO*) that considers this approach and show that it is insufficient to provide starvation freedom.

Contributions of the paper:

- We propose a multi-version starvation-free STM system as *K-version starvation-free STM* or *KSFTM* for a given parameter K . Here K is the number of versions of each t-object and can range from 1 to ∞ . To the best of our knowledge, this is the first starvation-free MVSTM. We develop *KSFTM* algorithm in a step-wise manner starting from MVTO [17] as follows:
 - First, in SubSection 3.3, we use the standard idea to provide higher priority to older transactions. Specifically, we propose priority-based K -version STM algorithm *Priority-based K-version MVTO* or *PKTO*. This algorithm guarantees the safety properties of strict-serializability and local opacity. However, it is not starvation-free.
 - We analyze *PKTO* to identify the characteristics that will help us to achieve preventing a transaction from getting aborted forever. This analysis leads us to the development of *starvation-free K-version TO* or *SFKTO* (SubSection 3.5), a multi-version starvation-free STM obtained by revising *PKTO*. But SFKTO does not satisfy correctness, i.e., strict-serializability, and local opacity.
 - Finally, we extend SFKTO to develop *KSFTM* (SubSection 3.6) that preserves the starvation-freedom, strict-serializability, and local opacity. Our algorithm works on the assumption that any transaction that is not deadlocked, terminates (commits or aborts) in a bounded time.
- Our experiments (Section 4) show that *KSFTM* gives an average speedup on the worst-case time to commit of a transaction by a factor of 1.22, 1.89, 23.26 and 13.12 times over *PKTO*, *SV-SFTM*, NOrec STM [6] and ESTM [7] respectively for counter application. *KSFTM* performs 1.5 and 1.44 times better than *PKTO* and *SV-SFTM* but 1.09 times worse than NOrec for low contention KMEANS application of STAMP [21] benchmark whereas *KSFTM* performs 1.14, 1.4 and 2.63 times better than *PKTO*, *SV-SFTM* and NOrec for LABYRINTH application of STAMP benchmark which has high contention with long-running transactions.

2 System Model and Preliminaries

Following [12, 19], we assume a system of n processes/threads, p_1, \dots, p_n that access a collection of *transactional objects* (or *t-objects*) via atomic *transactions*. Each transaction has a unique identifier. Within a transaction, processes can perform *transactional operations or methods*: *stm-begin* that begins a transaction, *stm-write*(x, v) operation that updates a t-object x with value v in its local memory, the *stm-read*(x) operation tries to read x , *stm-tryC*() that tries to commit the transaction and returns *commit* if it succeeds, and *stm-tryA*() that aborts the transaction and returns \mathcal{A} . For the sake of presentation simplicity, we assume that the values taken as arguments by *stm-write* operations are unique.

Operations *stm-read* and *stm-tryC*() may return \mathcal{A} , in which case we say that the operations *forcefully abort*. Otherwise, we say that the operations have *successfully* executed. Each operation is equipped with a unique transaction identifier. A transaction T_i starts with the first operation and completes when any of its operations return \mathcal{A} or \mathcal{C} . We denote any operation that returns \mathcal{A} or \mathcal{C} as *terminal operations*. Hence, operations *stm-tryC*() and *stm-tryA*() are terminal operations. A transaction does not invoke any further operations after terminal operations.

For a transaction T_k , we denote all the t-objects accessed by its read operations as $rset_k$ and t-objects accessed by its write operations as $wset_k$. We denote all the operations of a transaction T_k as $T_k.evts$ or $evts_k$.

History: A *history* is a sequence of *events*, i.e., a sequence of invocations and responses of transactional operations. The collection of events is denoted as $H.evts$. For simplicity, we only consider *sequential* histories here: the invocation of each transactional operation is immediately followed by a matching response. Therefore, we treat each transactional operation as one atomic event, and let $<_H$ denote the total order on the transactional operations incurred by H . With this assumption, the only relevant events of a transaction T_k is of the types: $r_k(x, v)$, $r_k(x, \mathcal{A})$, $w_k(x, v)$, *stm-tryC* $_k(\mathcal{C})$ (or c_k for short), *stm-tryC* $_k(\mathcal{A})$, *stm-tryA* $_k(\mathcal{A})$ (or a_k for short). We identify a history H as tuple $\langle H.evts, <_H \rangle$.

Let $H|T$ denote the history consisting of events of T in H , and $H|p_i$ denote the history consisting of events of p_i in H . We only consider *well-formed* histories here, i.e., no transaction of a process begins before the previous transaction invocation has completed (either *commits* or *aborts*). We also assume that every history has an initial *committed* transaction T_0 that initializes all the t-objects with value 0.

The set of transactions that appear in H is denoted by $H.txns$. The set of *committed* (resp., *aborted*) transactions in H is denoted by $H.committed$ (resp., $H.aborted$). The set of *incomplete* or *live* transactions in H is denoted by $H.incomp = H.live = (H.txns - H.committed - H.aborted)$.

For a history H , we construct the *completion* of H , denoted as \bar{H} , by inserting *stm-tryA_k(\mathcal{A})* immediately after the last event of every transaction $T_k \in H.live$. But for *stm-tryC_i* of transaction T_i , if it released the lock on first t-object successfully that means updates made by T_i is consistent so, T_i will immediately return commit.

Transaction orders: For two transactions $T_k, T_m \in H.txns$, we say that T_k *precedes* T_m in the *real-time order* of H , denote $T_k \prec_H^{RT} T_m$, if T_k is complete in H and the last event of T_k precedes the first event of T_m in H . If neither $T_k \prec_H^{RT} T_m$ nor $T_m \prec_H^{RT} T_k$, then T_k and T_m *overlap* in H . We say that a history is *t-sequential* if all the transactions are ordered by this real-time order. Note that from our earlier assumption all the transactions of a single process are ordered by real-time.

Sub-history: A *sub-history* (SH) of a history (H) denoted as the tuple $\langle SH.evts, \prec_{SH} \rangle$ and is defined as: (1) $\prec_{SH} \subseteq \prec_H$; (2) $SH.evts \subseteq H.evts$; (3) If an event of a transaction $T_k \in H.txns$ is in SH then all the events of T_k in H should also be in SH .

For a history H , let R be a subset of $H.txns$. Then $H.subhist(R)$ denotes the sub-history of H that is formed from the operations in R .

Valid and legal history: A successful read $r_k(x, v)$ (i.e., $v \neq \mathcal{A}$) in a history H is said to be *valid* if there exist a transaction T_j that wrote v to x and *committed* before $r_k(x, v)$. Formally, $\langle r_k(x, v) \rangle$ is valid $\Leftrightarrow \exists T_j : (c_j \prec_H r_k(x, v)) \wedge (w_j(x, v) \in T_j.evts) \wedge (v \neq \mathcal{A})$. The history H is valid if all its successful read operations are valid.

We define $r_k(x, v)$'s *lastWrite* as the latest commit event c_i preceding $r_k(x, v)$ in H such that $x \in wset_i(T_i)$ can also be T_0 . A successful read operation $r_k(x, v)$, is said to be *legal* if the transaction containing r_k 's lastWrite also writes v onto x : $\langle r_k(x, v) \rangle$ is legal $\Leftrightarrow (v \neq \mathcal{A}) \wedge (H.lastWrite(r_k(x, v)) = c_i) \wedge (w_i(x, v) \in T_i.evts)$. The history H is legal if all its successful read operations are legal. From the definitions we get that if H is legal then it is also valid.

Opacity and Strict Serializability: We say that two histories H and H' are *equivalent* if they have the same set of events. Now a history H is said to be *opaque* [11, 12] if it is valid and there exists a t-sequential legal history S such that (1) S is equivalent to \bar{H} and (2) S respects \prec_H^{RT} , i.e., $\prec_H^{RT} \subset \prec_S^{RT}$. By requiring S being equivalent to \bar{H} , opacity treats all the incomplete transactions as aborted. We call S an (opaque) *serialization* of H .

Along same lines, a valid history H is said to be *strictly serializable* if $H.subhist(H.committed)$ is opaque. Unlike opacity, strict serializability does not include aborted or incomplete transactions in the global serialization order. An opaque history H is also strictly serializable: a serialization of $H.subhist(H.committed)$ is simply the subsequence of a serialization of H that only contains transactions in $H.committed$.

Serializability is commonly used criterion in databases. But it is not suitable for STMs as it does not consider the correctness of *aborted* transactions as shown by Guerraoui & Kapalka [11]. Opacity, on the other hand, considers the correctness of *aborted* transactions as well. Similarly, local opacity (described below) is another correctness-criterion for STMs but is not as restrictive as opacity.

Local opacity: For a history H , we define a set of sub-histories, denoted as $H.subhistSet$ as follows: (1) For each aborted transaction T_i , we consider a *subhist* consisting of operations from all previously *committed* transactions and including all successful operations of T_i (i.e., operations which did not return \mathcal{A}) while immediately putting commit after last successful operation of T_i ; (2) for last *committed* transaction T_l considers all the previously *committed* transactions including T_l .

A history H is said to be *locally-opaque* [18, 19] if all the sub-histories in $H.subhistSet$ are opaque. It must be seen that in the construction of sub-history of an aborted transaction T_i , the *subhist* will contain operations from only one aborted transaction which is T_i itself and no other live/aborted transactions. Similarly, the sub-history of *committed* transaction T_l has no operations of aborted and live transactions. Thus in local opacity, no aborted or live transaction can cause another transaction to abort. It was shown that local opacity [18, 19] allows greater concurrency than opacity. Any history that is opaque is also locally-opaque but not necessarily the vice-versa. On the other hand, a history that is locally-opaque is also strict-serializable, but the vice-versa need not be true.

Graph Characterization of Local Opacity: To prove correctness of STM systems, it is useful to consider graph characterization of histories. In this section, we describe the graph characterization developed by Kumar et al [17] for proving opacity which is based on characterization by Bernstein and Goodman [2]. We extend this characterization for LO.

Consider a history H which consists of multiple versions for each t-object. The graph characterization uses the notion of *version order*. Given H and a t-object x , we define a version order for x as any (non-reflexive) total order on all the versions of x ever created by committed transactions in H . It must be noted that the version order may or may not be the same as the actual order in which the version of x are generated in H . A version order of H , denoted as \ll_H is the union of the version orders of all the t-objects in H .

Consider the history $H2 : r_1(x, 0)r_2(x, 0)r_1(y, 0)r_3(z, 0)w_1(x, 5)w_3(y, 15)w_2(y, 10)w_1(z, 10)c_1c_2r_4(x, 5)r_4(y, 10)w_3(z, 15)c_3r_4(z, 10)$. Using the notation that a committed transaction T_i writing to x creates a version x_i , a possible version order for $H2 \ll_{H2}$ is: $\langle x_0 \ll x_1 \rangle, \langle y_0 \ll y_2 \ll y_3 \rangle, \langle z_0 \ll z_1 \ll z_3 \rangle$.

We define the graph characterization based on a given version order. Consider a history H and a version order \ll . We then define a graph (called opacity graph) on H using \ll , denoted as $OPG(H, \ll) = (V, E)$. The vertex set V consists of a vertex for each transaction T_i in \bar{H} . The edges of the graph are of three kinds and are defined as follows:

1. *real-time*(real-time) edges: If T_i commits before T_j starts in H , then there is an edge from v_i to v_j . This set of edges are referred to as $rt(H)$.
2. *rf*(reads-from) edges: If T_j reads x from T_i in H , then there is an edge from v_i to v_j . Note that in order for this to happen, T_i must have committed before T_j and $c_i <_H r_j(x)$. This set of edges are referred to as $rf(H)$.
3. *mv*(multiversion) edges: The mv edges capture the multiversion relations and is based on the version order. Consider a successful read operation $r_k(x, v)$ and the write operation $w_j(x, v)$ belonging to transaction T_j such that $r_k(x, v)$ reads x from $w_j(x, v)$ (it must be noted T_j is a committed transaction and $c_j <_H r_k$). Consider a committed transaction T_i which writes to x , $w_i(x, u)$ where $u \neq v$. Thus the versions created x_i, x_j are related by \ll . Then, if $x_i \ll x_j$ we add an edge from v_i to v_j . Otherwise ($x_j \ll x_i$), we add an edge from v_k to v_i . This set of edges are referred to as $mv(H, \ll)$.

Using the construction, the $OPG(H2, \ll_{H2})$ for history $H2$ and \ll_{H2} is shown in Fig 14. The edges are annotated. The only mv edge from $T4$ to $T3$ is because of t-objects y, z . $T4$ reads value 5 for z from $T1$ whereas $T3$ also writes 15 to z and commits before $r_4(z)$.

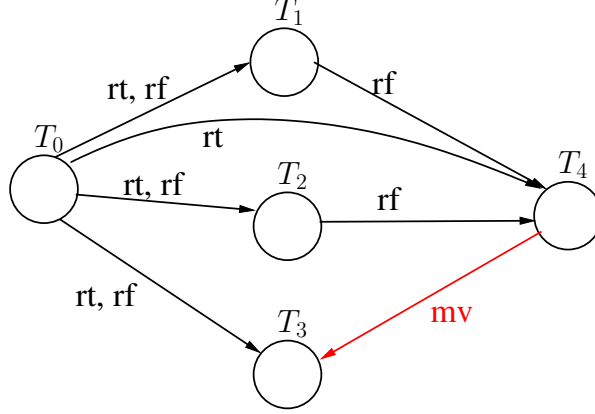

Figure 2: $OPG(H2, \ll_{H2})$

Kumar et al [17] showed that if a version order \ll exists for a history H such that $OPG(H, \ll_H)$ is acyclic, then H is opaque. This is captured in the following result.

Result 1 A valid history H is opaque iff there exists a version order \ll_H such that $OPG(H, \ll_H)$ is acyclic.

This result can be easily extended to prove LO as follows

Theorem 2 A valid history H is locally-opaque iff for each sub-history sh in $H.subhistSet$ there exists a version order \ll_{sh} such that $OPG(sh, \ll_{sh})$ is acyclic. Formally, $\langle (H \text{ is locally-opaque}) \Leftrightarrow (\forall sh \in H.subhistSet, \exists \ll_{sh}: OPG(sh, \ll_{sh}) \text{ is acyclic}) \rangle$.

Proof. To prove this theorem, we have to show that each sub-history sh in $H.subhistSet$ is valid. Then the rest follows from Result 9. Now consider a sub-history sh . Consider any read operation $r_i(x, v)$ of a transaction T_i . It

is clear that T_i must have read a version of x created by a previously committed transaction. From the construction of sh , we get that all the transaction that committed before r_i are also in sh . Hence sh is also valid.

Now, proving sh to be opaque iff there exists a version order \ll_{sh} such that $OPG(sh, \ll_{sh})$ is acyclic follows from Result 9.

3 The Working of *KSFTM* Algorithm

In this section, we propose *K-version starvation-free STM* or *KSFTM* for a given parameter K . Here K is the number of versions of each t-object and can range from 1 to ∞ . When K is 1, it boils down to single-version *starvation-free STM*. If K is ∞ , then *KSFTM* uses unbounded versions and needs a separate garbage collection mechanism to delete old versions like other MVSTMs proposed in the literature [17, 20]. We denote *KSFTM* using unbounded versions as *UVSFTM* and *UVSFTM* with garbage collection as *UVSFTM-GC*.

Next, we describe some *starvation-freedom* preliminaries in SubSection 3.1 to explain the working of *KSFTM* algorithm. To explain the intuition behind the *KSFTM* algorithm, we start with the modification of MVTO [2, 17] algorithm in SubSection 3.3. We then make a sequence of modifications to it to arrive at *KSFTM* algorithm.

3.1 Starvation-Freedom Preliminaries

In this section, we start with the definition of *starvation-freedom*. Then we describe the invocation of transactions by the application. Next, we describe the data structures used by the algorithms.

Definition 1 Starvation-Freedom: A STM system is said to be *starvation-free* if a thread invoking a non-parasitic transaction T_i gets the opportunity to retry T_i on every abort, due to the presence of a fair scheduler, then T_i will eventually commit.

As explained by Herlihy & Shavit [14], a fair scheduler implies that no thread is forever delayed or crashed. Hence with a fair scheduler, we get that if a thread acquires locks then it will eventually release the locks. Thus a thread cannot block out other threads from progressing.

Assumption about Scheduler: In order for starvation-free algorithm *KSFTM* (described in SubSection 3.6) to work correctly, we make the following assumption about the fair scheduler:

Assumption 1 Bounded-Termination: For any transaction T_i , invoked by a thread Th_x , the fair system scheduler ensures, in the absence of deadlocks, Th_x is given sufficient time on a CPU (and memory etc.) such that T_i terminates (either commits or aborts) in bounded time.

While the bound for each transaction may be different, we use L to denote the maximum bound. In other words, in time L , every transaction will either abort or commit due to the absence of deadlocks.

There are different ways to satisfy the scheduler requirement. For example, a round-robin scheduler which provides each thread equal amount of time in any window satisfies this requirement as long as the number of threads is bounded. In a system with two threads, even if a scheduler provides one thread 1% of CPU and another thread 99% of the CPU, it satisfies the above requirement. On the other hand, a scheduler that schedules the threads as ' $T_1, T_2, T_1, T_2, T_2, T_1, T_2, T_2, T_2, T_2, T_1, T_2, T_2, T_2, T_2, T_2, T_2, T_2, T_1, T_2$ (16times)'

 does not satisfy the above requirement. This is due to the fact that over time, thread 1 gets infinitesimally smaller portion of the CPU and, hence, the time required for it to complete (commit or abort) will continue to increase over time.

In our algorithm, we will ensure that it is deadlock free using standard techniques from the literature. In other words, each thread is in a position to make progress. We assume that the scheduler provides sufficient CPU time to complete (either commit or abort) within a bounded time.

As explained by Herlihy & Shavit [14], a fair scheduler implies that no thread is forever delayed or crashed. Hence with a fair scheduler, we get that if a thread acquires locks then it will eventually release the locks. Thus a thread cannot block out other threads from progressing.

Transaction Invocation: Transactions are invoked by threads. Suppose a thread Th_x invokes a transaction T_i . If this transaction T_i gets *aborted*, Th_x will reissue it, as a new incarnation of T_i , say T_j . The thread Th_x will continue to invoke new incarnations of T_i until an incarnation commits.

When the thread Th_x invokes a transaction, say T_i , for the first time then the STM system assigns T_i a unique timestamp called *current timestamp* or *CTS*. If it aborts and retries again as T_j , then its CTS will change. However,

in this case, the thread Th_x will also pass the CTS value of the first incarnation (T_i) to T_j . By this, Th_x informs the STM system that, T_j is not a new invocation but is an incarnation of T_i .

We denote the CTS of T_i (first incarnation) as *Initial Timestamp or ITS* for all the incarnations of T_i . Thus, the invoking thread Th_x passes cts_i to all the incarnations of T_i (including T_j). Thus for T_j , $its_j = cts_i$. The transaction T_j is associated with the timestamps: $\langle its_j, cts_j \rangle$. For T_i , which is the initial incarnation, its ITS and CTS are the same, i.e., $its_i = cts_i$. For simplicity, we use the notation that for transaction T_j , j is its CTS, i.e., $cts_j = j$.

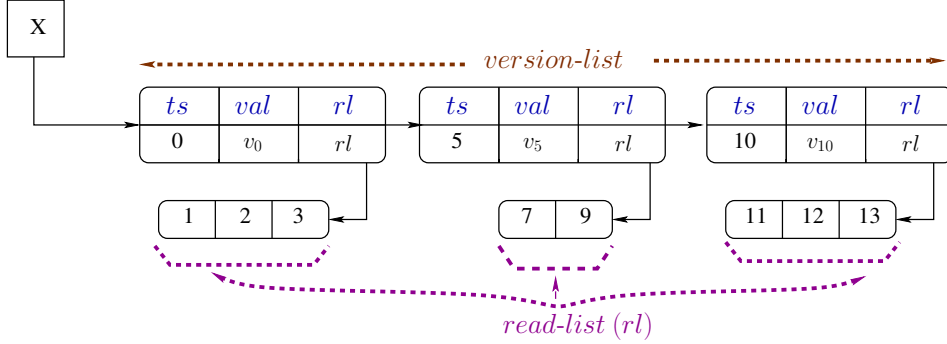

Figure 3: Data Structures for Maintaining Versions

We also assume that in the absence of other concurrent conflicting transactions, every transaction will commit. In other words, if a transaction is executing in a system where other concurrent conflicting transactions are not present then it will not self-abort. If transactions can self-abort then providing *starvation-freedom* is impossible.

Common Data Structures and STM Methods: Here we describe the common data structures used by all the algorithms proposed in this section. For each t-object, the algorithms maintain multiple versions in *version-list* (or *vlist*) using list. Similar to versions in MVTO [17], each version of a t-object is a tuple denoted as $vTuple$ and consists of three fields: (1) timestamp, (or *ts*) of the transaction that created this version which normally is the CTS; (2) the value (or *val*) of the version; (3) a list, called read-list (or *rl*), consisting of transactions ids (can be CTS as well) that read from this version. The read-list of a version is initially empty. Fig 3 illustrates this structure. For a t-object x , we use the notation $x[t]$ to access the version with timestamp t . Depending on the algorithm considered, the fields change of this structure.

The algorithms have access to a global atomic counter, G_tCntr used for generating timestamps in the various transactional methods. We assume that the STM system exports the following methods for a transaction T_i : (1) $stm_begin(t)$ where t is provided by the invoking thread, Th_x . From our earlier assumption, it is the CTS of the first incarnation. In case Th_x is invoking this transaction for the first time, then t is *null*. This method returns a unique timestamp to Th_x which is the CTS/id of the transaction. (2) $stm_read_i(x)$ tries to read t-object x . It returns either value v or \mathcal{A} . (3) $stm_write_i(x, v)$ operation that updates a t-object x with value v locally. It returns *ok*. (4) $stm_tryC_i()$ tries to commit the transaction and returns \mathcal{C} if it succeeds. Otherwise, it returns \mathcal{A} .

Correctness Criteria: For ease of exposition, we initially consider strict-serializability as *correctness-criterion* to illustrate the correctness of the algorithms. But strict-serializability does not consider the correctness of *aborted* transactions and as a result not a suitable *correctness-criterion* for STMs. Finally, we show that the proposed STM algorithm *KSFTM* satisfies local opacity, a *correctness-criterion* for STMs (described in Section 2). We denote the set of histories generated by an STM algorithm, say A , as $gen(A)$.

3.2 Motivation for Starvation Freedom in Multi-Version Systems

In this section, first we describe the starvation freedom solution used for single version i.e. *SV-SFTM* algorithm and then the drawback of it.

3.2.1 Illustration of SV-SFTM

Forward-oriented optimistic concurrency control protocol (FOCC), is a commonly used optimistic algorithm in databases [28, Chap 4]. In fact, several STM Systems are also based on this idea. In a typical STM system (also in database optimistic concurrency control algorithms), a transaction execution is divided can be two phases - a *read/local-write phase* and *try-Commit phase* (also referred to as validation phase in databases). The various algorithms differ in how the try-Commit phase executes. Let the write-set or wset and read-set or rset of a t_i

denotes the set of t-objects written & read by t_i . In FOCC a transaction t_i in its try-Commit phase is validated against all live transactions that are in their read/local-write phase as follows: $\langle wset(t_i) \cap (\forall t_j : rset^n(t_j)) = \Phi \rangle$. This implies that the wset of t_i can not have any conflict with the current rset of any transaction t_j in its read/local-write phase. Here $rset^n(t_j)$ implies the rset of t_j till the point of validation of t_i . If there is a conflict, then either t_i or t_j (all transactions conflicting with t_i) is aborted. A commonly used approach in databases is to abort t_i , the validating transaction.

In *SV-SFTM* we use t_{ss} which are monotonically in increasing order. We implement the t_{ss} using atomic counters. Each transaction t_i has two time-stamps: (i) *current time-stamp or CTS*: this is a unique t_{ss} allotted to t_i when it begins; (ii) *initial time-stamp or ITS*: this is same as CTS when a transaction t_i starts for the first time. When t_i aborts and re-starts later, it gets a new CTS. But it retains its original CTS as ITS. The value of ITS is retained across aborts. For achieving starvation freedom, *SV-SFTM* uses ITS with a modification to FOCC as follows: a transaction t_i in try-Commit phase is validated against all other conflicting transactions, say t_j which are in their read/local-write phase. The ITS of t_i is compared with the ITS of any such transaction t_j . If ITS of t_i is smaller than ITS of all such t_j , then all such t_j are aborted while t_i is committed. Otherwise, t_i is aborted. We show that *SV-SFTM* satisfies opacity and starvation-free.

Theorem 3 Any history generated by *SV-SFTM* is opaque.

Theorem 4 *SV-SFTM* ensure starvation-freedom.

We prove the correctness by showing that the conflict graph [28, Chap 3], [18] of any history generated by *SV-SFTM* is acyclic. We show starvation-freedom by showing that for each transaction t_i there eventually exists a global state in which it has the smallest ITS.

Fig 4 shows the a sample execution of *SV-SFTM*. It compares the execution of FOCC with *SV-SFTM*. The execution on the left corresponds to FOCC, while the execution one the right is of *SV-SFTM* for the same input. It can be seen that each transaction has two t_{ss} in *SV-SFTM*. They correspond to CTS, ITS respectively. Thus, transaction $T_{1,1}$ implies that CTS and ITS are 1. In this execution, transaction T_3 executes the read operation $r_3(z)$ and is aborted due to conflict with T_2 . The same happens with $T_{3,3}$. Transaction T_5 is re-execution of T_3 . With FOCC T_5 again aborts due to conflict with T_4 . In case of *SV-SFTM*, $T_{5,3}$ which is re-execution of $T_{3,3}$ has the same ITS 3. Hence, when $T_{4,4}$ validates in *SV-SFTM*, it aborts as $T_{5,3}$ has lower ITS. Later $T_{5,3}$ commits.

It can be seen that ITSs prioritizes the transactions under conflict and the transaction with lower ITS is given higher priority.

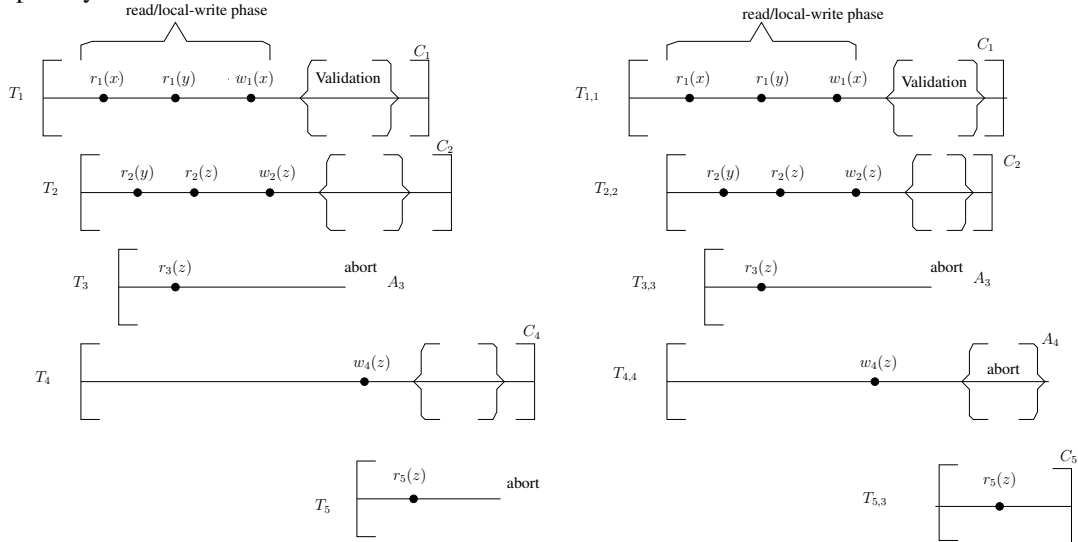

Figure 4: Sample execution of *SV-SFTM*

3.2.2 Drawback of *SV-SFTM*

Figure 5 is representing history H: $r_1(x, 0)r_1(y, 0)w_2(x, 10)w_3(y, 15)a_2a_3c_1$. It has three transactions T_1, T_2 and T_3 . T_1 is having lowest time stamp and after reading it became slow. T_2 and T_3 wants to write to x and y respectively but when it came into validation phase, due to $r_1(x)$, $r_1(y)$ and not committed yet, T_2 and T_3 gets

aborted. However, when we are using multiple version T_2 and T_3 both can commit and T_1 can also read from T_0 . The equivalent serial history is $T_1T_2T_3$.

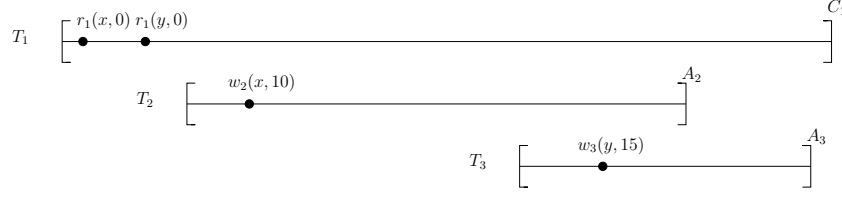

Figure 5: Pictorial representation of execution under SFTM

3.2.3 Data Structures and Pseudocode of SV-SFTM

We start with data-structures that are local to each transaction. For each transaction T_i :

- $rset_i$ (read-set): It is a list of data tuples (d_tuples) of the form $\langle x, val \rangle$, where x is the t-object and v is the value read by the transaction T_i . We refer to a tuple in T_i 's read-set by $rset_i[x]$.
- $wset_i$ (write-set): It is a list of (d_tuples) of the form $\langle x, val \rangle$, where x is the t-object to which transaction T_i writes the value val . Similarly, we refer to a tuple in T_i 's write-set by $wset_i[x]$.

In addition to these local structures, the following shared global structures are maintained that are shared across transactions (and hence, threads). We name all the shared variable starting with 'G'.

- G_tCntr (counter): This a numerical valued counter that is incremented when a transaction begins.

For each transaction T_i we maintain the following shared time-stamps:

- G_lock_i : A lock for accessing all the shared variables of T_i .
- G_its_i (initial timestamp): It is a time-stamp assigned to T_i when it was invoked for the first time.
- G_cts_i (current timestamp): It is a time-stamp when T_i is invoked again at a later time. When T_i is created for the first time, then its G_cts is same as its its .
- G_valid_i : This is a boolean variable which is initially true (T). If it becomes false (F) then T_i has to be aborted.
- G_state_i : This is a variable which states the current value of T_i . It has three states: live, commit or abort.

For each data item x in history H , we maintain:

- $x.val$ (value): It is the successful previous closest value written by any transaction.
- $x.rl$ (readList): It is the read list consists of all the transactions that have read x .

Algorithm 2 STM $init()$: Invoked at the start of the STM system. Initializes all the data items used by the STM System

- 1: $G_tCntr = 1$;
 - 2: **for all** data item x used by the STM System **do**
 - 3: add $\langle 0, nil \rangle$ to $x.val$; /* T_0 is initializing x */
 - 4: **end for**;
-

Algorithm 5 STM $write_i(x, val)$: A Transaction T_i writes into local memory

- 1: Append the $d_tuple \langle x, val \rangle$ to $wset_i$; /* If same dataitem then overwrite the tuple */
 - 2: return ok ;
-

Algorithm 3 STM *stm-begin(its)*: Invoked by a thread to start a new transaction T_i . Thread can pass a parameter *its* which is the initial timestamp when this transaction was invoked for the first time. If this is the first invocation then *its* is *nil*. It returns the tuple $\langle id, G_cts \rangle$

```

1:  $i = \text{unique-id}$ ; /* An unique id to identify this transaction. It could be same as  $G\_cts$ . */
2: if ( $its == nil$ ) then
3:    $G\_its_i = G\_cts_i = G\_tCntr.get\&Inc()$ ;
4:   /*  $G\_tCntr.get\&Inc()$  returns the current value of  $G\_tCntr$  and atomically increments it by 1. */
5: else
6:    $G\_its_i = its$ ;
7:    $G\_cts_i = G\_tCntr.get\&Inc()$ ;
8: end if
9:  $rset_i = wset_i = null$ ;
10:  $G\_state_i = \text{live}$ ;
11:  $G\_valid_i = T$ ;
12: return  $\langle i, G\_cts_i \rangle$ 

```

Algorithm 4 STM *read(i, x)*: Invoked by a transaction T_i to read x . It returns either the value of x or \mathcal{A}

```

1: if ( $x \in wset_i$ ) then /* Check if  $x$  is in  $wset_i$  */
2:   return  $wset_i[x].val$ ;
3: else if ( $x \in rset_i$ ) then /* Check if  $x$  is in  $rset_i$  */
4:   return  $rset_i[x].val$ ;
5: else /*  $x$  is not in  $rset_i$  and  $wset_i$  */
6:   lock  $x$ ;
7:   lock  $G\_lock_i$ ;
8:   if ( $G\_valid_i == F$ ) then
9:     return  $abort(i)$ ;
10:  end if
11:   $val = x.val$ ;
12:  add  $T_i$  to  $x.rl$ ;
13:  unlock  $G\_lock_i$ ;
14:  unlock  $x$ ;
15:  return  $val$ ;
16: end if

```

Algorithm 6 STM *findLLTS(TSet)*: Find the lowest *its* value among all the live trasactions in *TSet*.

```

1:  $min\_its = \infty$ 
2: for all ( $T_j \in TSet$ ) do
3:   if ( $(G\_its_j < min\_its) \ \&\& \ (G\_state_j == live)$ ) then
4:      $min\_its = G\_its_j$ ;
5:   end if
6: end for
7: return  $min\_its$ ;

```

Algorithm 7 STM *stm-tryC()*: Returns \mathcal{C} on commit else return Abort \mathcal{A}

```

1: lock  $G\_lock_i$ 
2: if ( $G\_valid_i == F$ ) then return  $abort(i)$ ;
3: end if
4:  $TSet = null$  /*  $TSet$  storing transaction Ids */
5: for all ( $x \in wset_i$ ) do
6:   lock  $x$  in pre-defined order;
7:   for all ( $T_j \in x.rl$ ) do
8:      $TSet = TSet \cup \{T_j\}$ 
9:   end for
10: end for /*  $x \in wset_i$  */
11:  $TSet = TSet \cup \{T_i\}$  /* Add current transaction  $T_i$  into  $TSet$  */
12: for all ( $T_k \in TSet$ ) do
13:   lock  $G\_lock_k$  in pre-defined order; /* Note: Since  $T_i$  is also in  $TSet$ ,  $G\_lock_i$  is also locked */
14: end for
15: if ( $G\_valid_i == F$ ) then return  $abort(i)$ ;
16: else
17:   if ( $G\_its_i == findLLTS(TSet)$ ) then /* Check if  $T_i$  has lowest  $its$  among all live transactions in  $TSet$  */
18:     for all ( $T_j \in TSet$ ) do /* ( $T_i \neq T_j$ ) */
19:        $G\_valid_j = F$ 
20:       unlock  $G\_lock_j$ ;
21:     end for
22:   else
23:     return  $abort(i)$ ;
24:   end if
25: end if
26: for all ( $x \in wset_i$ ) do
27:   replace the old value in  $x.val$  with  $newValue$ ;
28:    $x.rl = null$ ;
29: end for
30:  $G\_state_i = commit$ ;
31: unlock all variables locked by  $T_i$ ;
32: return  $\mathcal{C}$ ;

```

Algorithm 8 *abort(i)*: Invoked by various STM methods to abort transaction T_i . It returns \mathcal{A}

```

1:  $G\_valid_i = F$ ;
2:  $G\_state_i = abort$ ;
3: unlock all variables locked by  $T_i$ ;
4: return  $\mathcal{A}$ ;

```

Simplifying Assumptions: We next describe the main idea behind the starvation-free STM algorithm *KSFTM* through a sequence of algorithms. For ease of exposition, we make two simplifying assumptions (1) We assume that in the absence of other concurrent conflicting transactions, every transaction will commit. In other words, if a transaction is executed in a system by itself, it will not self-abort. (2) We initially consider strict-serializability as correctness-criterion to illustrate the correctness of the algorithms. But strict-serializability does not consider the correctness of aborted transactions and as a result not a suitable correctness-criterion for STMs. Finally, we show

that the proposed STM algorithm *KSFTM* satisfies local opacity, a correctness-criterion for STMs. We denote the set of histories generated by an STM algorithm, say A , as $gen(A)$.

3.3 Priority-based MVTO Algorithm

In this subsection, we describe a modification to the multi-version timestamp ordering (MVTO) algorithm [2, 17] to ensure that it provides preference to transactions that have low ITS, i.e., transactions that have been in the system for a longer time. We denote the basic algorithm which maintains unbounded versions as *Priority-based MVTO* or *PMVTO* (akin to the original MVTO). We denote the variant of *PMVTO* that maintains K versions as *PKTO* and the unbounded versions variant with garbage collection as *PMVTO-GC*. In this sub-section, we specifically describe *PKTO*. But most of these properties apply to *PMVTO* and *PMVTO-GC* as well.

stm-begin(t): A unique timestamp ts is allocated to T_i which is its CTS (i from our assumption). The timestamp ts is generated by atomically incrementing the global counter G_tCntr . If the input t is null, then $cts_i = its_i = ts$ as this is the first incarnation of this transaction. Otherwise, the non-null value of t is assigned as its_i .

stm-read(x): Transaction T_i reads from a version of x in the shared memory (if x does not exist in T_i 's local buffer) with timestamp j such that j is the largest timestamp less than i (among the versions x), i.e., there exists no version of x with timestamp k such that $j < k < i$. After reading this version of x , T_i is stored in $x[j]$'s read-list. If no such version exists then T_i is *aborted*.

stm-write(x, v): T_i stores this write to value x locally in its $wset_i$. If T_i ever reads x again, this value will be returned.

stm-tryC: This operation consists of three steps. In Step 1, it checks whether T_i can be *committed*. In Step 2, it performs the necessary tasks to mark T_i as a *committed* transaction and in Step 3, T_i return commits.

1. Before T_i can commit, it needs to verify that any version it creates does not violate consistency. Suppose T_i creates a new version of x with timestamp i . Let j be the largest timestamp smaller than i for which version of x exists. Let this version be $x[j]$. Now, T_i needs to make sure that any transaction that has read $x[j]$ is not affected by the new version created by T_i . There are two possibilities of concern:
 - (a) Let T_k be some transaction that has read $x[j]$ and $k > i$ ($k = \text{CTS of } T_k$). In this scenario, the value read by T_k would be incorrect (w.r.t strict-serializability) if T_i is allowed to create a new version. In this case, we say that the transactions T_i and T_k are in *conflict*. So, we do the following:
 - (i) if T_k has already *committed* then T_i is *aborted*;
 - (ii) if T_k is live and its_k is less than its_i . Then again T_i is *aborted*;
 - (iii) If T_k is still live with its_i less than its_k then T_k is *aborted*.
 - (b) The previous version $x[j]$ does not exist. This happens when the previous version $x[j]$ has been overwritten. In this case, T_i is *aborted* since *PKTO* does not know if T_i conflicts with any other transaction T_k that has read the previous version.
2. After Step 1, we have verified that it is ok for T_i to commit. Now, we have to create a version of each t-object x in the $wset$ of T_i . This is achieved as follows:
 - (a) T_i creates a $vTuple \langle i, wset_i.x.v, null \rangle$. In this tuple, i (CTS of T_i) is the timestamp of the new version; $wset_i.x.v$ is the value of x in T_i 's $wset$, and the read-list of the $vTuple$ is *null*.
 - (b) Suppose the total number of versions of x is K . Then among all the versions of x , T_i replaces the version with the smallest timestamp with $vTuple \langle i, wset_i.x.v, null \rangle$. Otherwise, the $vTuple$ is added to x 's $vlist$.
3. Transaction T_i is then *committed*.

The algorithm described here is only the main idea. The actual implementation will use locks to ensure that each of these methods are linearizable [16]. It can be seen that *PKTO* gives preference to the transaction having lower ITS in Step 1a. Transactions having lower ITS have been in the system for a longer time. Hence, *PKTO* gives preference to them.

3.4 Pseudocode of PKTO

Algorithm 9 STM *init*(\emptyset): Invoked at the start of the STM system. Initializes all the t-objects used by the STM System

```

1:  $G\_tCntr = 1$ ;
2: for all  $x$  in  $\mathcal{T}$  do /* All the t-objects used by the STM System */
3:   add  $\langle 0, 0, nil \rangle$  to  $x.v\perp$ ; /*  $T_0$  is initializing  $x$  */
4: end for;

```

Algorithm 10 STM *stm-begin*(its): Invoked by a thread to start a new transaction T_i . Thread can pass a parameter its which is the initial timestamp when this transaction was invoked for the first time. If this is the first invocation then its is nil . It returns the tuple $\langle id, G_cts \rangle$

```

1:  $i = \text{unique-id}$ ; /* An unique id to identify this transaction. It could be same as  $G\_cts$  */
2: /* Initialize transaction specific local and global variables */
3: if ( $its == nil$ ) then
4:   /*  $G\_tCntr.get\&Inc()$  returns the current value of  $G\_tCntr$  and atomically increments it */
5:    $G\_its_i = G\_cts_i = G\_tCntr.get\&Inc()$ ;
6: else
7:    $G\_its_i = its$ ;
8:    $G\_cts_i = G\_tCntr.get\&Inc()$ ;
9: end if
10:  $rset_i = wset_i = null$ ;
11:  $G\_state_i = \text{live}$ ;
12:  $G\_valid_i = T$ ;
13: return  $\langle i, G\_cts_i \rangle$ 

```

Algorithm 11 STM *read*(i, x): Invoked by a transaction T_i to read t-object x . It returns either the value of x or \mathcal{A}

```

1: if ( $x \in rset_i$ ) then /* Check if the t-object  $x$  is in  $rset_i$  */
2:   return  $rset_i[x].val$ ;
3: else if ( $x \in wset_i$ ) then /* Check if the t-object  $x$  is in  $wset_i$  */
4:   return  $wset_i[x].val$ ;
5: else /* t-object  $x$  is not in  $rset_i$  and  $wset_i$  */
6:   lock  $x$ ; lock  $G\_lock_i$ ;
7:   if ( $G\_valid_i == F$ ) then return abort( $i$ );
8:   end if
9:   /* findLTS: From  $x.v\perp$ , returns the largest  $t_s$  value less than  $G\_cts_i$ . If no such version exists, it returns  $nil$  */
10:   $curVer = \text{findLTS}(G\_cts_i, x)$ ;
11:  if ( $curVer == nil$ ) then return abort( $i$ ); /* Proceed only if  $curVer$  is not nil */
12:  end if
13:   $val = x[curVer].v$ ; add  $\langle x, val \rangle$  to  $rset_i$ ;
14:  add  $T_i$  to  $x[curVer].rl$ ;
15:  unlock  $G\_lock_i$ ; unlock  $x$ ;
16:  return  $val$ ;
17: end if

```

Algorithm 12 STM *write* _{i} (x, val): A Transaction T_i writes into local memory

```

1: Append the  $d\_tuple\langle x, val \rangle$  to  $wset_i$ .
2: return  $ok$ ;

```

Algorithm 13 STM *stm-tryC()*: Returns *ok* on commit else return Abort

```

1: /* The following check is an optimization which needs to be performed again later */
2: lock  $G\_lock_i$ ;
3: if ( $G\_valid_i == F$ ) then
4:   return abort(i);
5: end if
6: unlock  $G\_lock_i$ ;
7:  $largeRL = allRL = nil$ ; /* Initialize larger read list (largeRL), all read list (allRL) to nil */
8: for all  $x \in wset_i$  do
9:   lock  $x$  in pre-defined order;
10:  /* findLTS: returns the version with the largest  $t_s$  value less than  $G\_cts_i$ . If no such version exists, it
    returns  $nil$ . */
11:   $prevVer = findLTS(G\_cts_i, x)$ ; /* prevVer: largest version smaller than  $G\_cts_i$  */
12:  if ( $prevVer == nil$ ) then /* There exists no version with  $t_s$  value less than  $G\_cts_i$  */
13:    lock  $G\_lock_i$ ; return abort(i);
14:  end if
15:  /* getLar: obtain the list of reading transactions of  $x[prevVer].rl$  whose  $G\_cts$  is greater than  $G\_cts_i$  */
16:   $largeRL = largeRL \cup getLar(G\_cts_i, x[prevVer].rl)$ ;
17: end for /*  $x \in wset_i$  */
18:  $relLL = largeRL \cup T_i$ ; /* Initialize relevant Lock List (relLL) */
19: for all ( $T_k \in relLL$ ) do
20:   lock  $G\_lock_k$  in pre-defined order; /* Note: Since  $T_i$  is also in  $relLL$ ,  $G\_lock_i$  is also locked */
21: end for
22: /* Verify if  $G\_valid_i$  is false */
23: if ( $G\_valid_i == F$ ) then
24:   return abort(i);
25: end if
26:  $abortRL = nil$  /* Initialize abort read list (abortRL) */
27: /* Among the transactions in  $T_k$  in  $largeRL$ , either  $T_k$  or  $T_i$  has to be aborted */
28: for all ( $T_k \in largeRL$ ) do
29:   if ( $isAborted(T_k)$ ) then /* Transaction  $T_k$  can be ignored since it is already aborted or about to be aborted
    */
30:     continue;
31:   end if
32:   if ( $G\_its_i < G\_its_k$ )  $\wedge$  ( $G\_state_k == live$ ) then
33:     /* Transaction  $T_k$  has lower priority and is not yet committed. So it needs to be aborted */
34:      $abortRL = abortRL \cup T_k$ ; /* Store  $T_k$  in abortRL */
35:   else /* Transaction  $T_i$  has to be aborted */
36:     return abort(i);
37:   end if
38: end for

```

Algorithm 14 *isAborted(T_k)*: Verifies if T_i is already aborted or its G_valid flag is set to false implying that T_i will be aborted soon

```

1: if ( $G\_valid_k == F$ )  $\vee$  ( $G\_state_k == abort$ )  $\vee$  ( $T_k \in abortRL$ ) then
2:   return  $T$ ;
3: else
4:   return  $F$ ;
5: end if

```

Algorithm 15 *abort(i)*: Invoked by various STM methods to abort transaction T_i . It returns \mathcal{A}

```

1:  $G\_valid_i = F$ ;  $G\_state_i = abort$ ;
2: unlock all variables locked by  $T_i$ ;
3: return  $\mathcal{A}$ ;

```

We have the following property on the correctness of *PKTO*.

```

39: /* Store the current value of the global counter as commit time and increment it */
40: comTime = G_ctr.get&Inc();
41: for all  $T_k \in abortRL$  do /* Abort all the transactions in abortRL */
42:    $G\_valid_k = F$ ;
43: end for
44: /* Having completed all the checks,  $T_i$  can be committed */
45: for all  $(x \in wset_i)$  do
46:   newTuple =  $\langle G\_cts_i, wset_i[x].val, nil \rangle$ ; /* Create new v_tuple: G_cts, val, rl for x */
47:   if  $(|x.vl| > k)$  then
48:     replace the oldest tuple in  $x.vl$  with newTuple; /*  $x.vl$  is ordered by timestamp */
49:   else
50:     add a newTuple to  $x.vl$  in sorted order;
51:   end if
52: end for /*  $x \in wset_i$  */
53:  $G\_state_i = commit$ ;
54: unlock all variables;
55: return  $\mathcal{C}$ ;

```

Property 5 Any history generated by PKTO is strict-serializable.

Consider a history H generated by PKTO. Let the committed sub-history of H be $CSH = H.subhist(H.committed)$. It can be shown that CSH is opaque with the equivalent serialized history SH' is one in which all the transactions of CSH are ordered by their CTs. Hence, H is strict-serializable.

Possibility of Starvation in PKTO: As discussed above, PKTO gives priority to transactions having lower ITS. But a transaction T_i having the lowest ITS could still abort due to one of the following reasons: (1) Upon executing *stm-read*(x) method if it does not find any other version of x to read from. This can happen if all the versions of x present have a timestamp greater than cts_i . (2) While executing Step 1a(i), of the *stm-tryC* method, if T_i wishes to create a version of x with timestamp i . But some other transaction, say T_k has read from a version with timestamp j and $j < i < k$. In this case, T_i has to abort if T_k has already committed.

This issue is not restricted only to PKTO. It can occur in PMVTO (and PMVTO-GC) due to the point (2) described above.

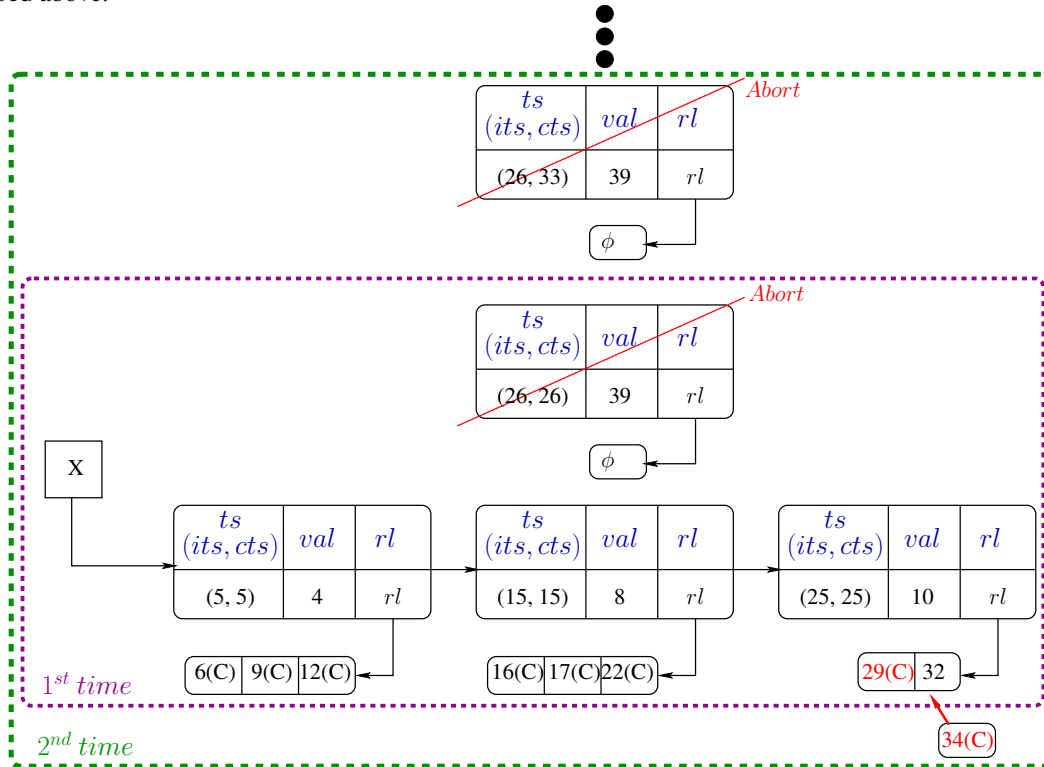

Figure 6: Pictorial representation of execution under PKTO

We illustrate this problem in *PKTO* with Fig 6. Here transaction T_{26} , with ITS 26 is the lowest among all the live transactions, starves due to Step 1a.(i) of the *stm-tryC*. *First time*, T_{26} gets *aborted* due to higher timestamp transaction T_{29} in the read-list of $x[25]$ has *committed*. We have denoted it by a ‘(C)’ next to the version. The *second time*, T_{26} retries with same ITS 26 but new CTS 33. Now when T_{33} comes for commit, suppose another transaction T_{34} in the read-list of $x[25]$ has already *committed*. So this will cause T_{33} (another incarnation of T_{26}) to abort again. Such scenario can possibly repeat again and again and thus causing no incarnation of T_{26} to ever commit leading to its starvation.

Garbage Collection in *UVSFTM-GC* and *PMVTO-GC*: Having multiple versions to increase the performance and to decrease the number of aborts, leads to creating too many versions which are not of any use and hence occupying space. So, such garbage versions need to be taken care of. Hence we come up with a garbage collection over these unwanted versions. This technique help to conserve memory space and increases the performance in turn as no more unnecessary traversing of garbage versions by transactions is necessary. We have used a global, i.e., across all transactions a list that keeps track of all the live transactions in the system. We call this list as *live-list*. Each transaction at the beginning of its life cycle creates its entry in this *live-list*. Under the optimistic approach of STM, each transaction in the shared memory performs its updates in the *stm-tryC* phase. In this phase, each transaction performs some validations, and if all the validations are successful then the transaction make changes or in simple terms creates versions of the corresponding t-object in the shared memory. While creating a version every transaction, check if it is the least timestamp live transaction present in the system by using *live-list* data structure, if yes then the current transaction deletes all the version of that t-object and create one of its own. Else the transaction does not do any garbage collection or delete any version and look for creating a new version of next t-object in the write set, if at all. Fig 10 and Fig 11 show that both *UVSFTM-GC* and *PMVTO-GC* performs better than *UVSFTM* and *PMVTO* across all workloads.

3.5 Modifying *PKTO* to Obtain *SFKTO*: Trading Correctness for *Starvation-Freedom*

Our goal is to revise *PKTO* algorithm to ensure that *starvation-freedom* is satisfied. Specifically, we want the transaction with the lowest ITS to eventually commit. Once this happens, the next non-committed transaction with the lowest ITS will commit. Thus, from induction, we can see that every transaction will eventually commit.

Key Insights For Eliminating Starvation in *PKTO*: To identify the necessary revision, we first focus on the effect of this algorithm on two transactions, say T_{50} and T_{60} with their CTS values being 50 and 60 respectively. Furthermore, for the sake of discussion, assume that these transactions only read and write t-object x . Also, assume that the latest version for x is with ts 40. Each transaction first reads x and then writes x (as part of the *stm-tryC* operation). We use r_{50} and r_{60} to denote their read operations while w_{50} and w_{60} to denote their *stm-tryC* operations. Here, a read operation will not fail as there is a previous version present.

Now, there are six possible permutations of these statements. We identify these permutations and the action that should be taken for that permutation in Table 1. In all these permutations, the read operations of a transaction come before the write operations as the writes to the shared memory occurs only in the *stm-tryC* operation (due to optimistic execution) which is the final operation of a transaction.

S. No	Sequence	Action
1.	$r_{50}, w_{50}, r_{60}, w_{60}$	T_{60} reads the version written by T_{50} . No conflict.
2.	$r_{50}, r_{60}, w_{50}, w_{60}$	Conflict detected at w_{50} . Either abort T_{50} or T_{60} .
3.	$r_{50}, r_{60}, w_{60}, w_{50}$	Conflict detected at w_{50} . Hence, abort T_{50} .
4.	$r_{60}, r_{50}, w_{60}, w_{50}$	Conflict detected at w_{50} . Hence, abort T_{50} .
5.	$r_{60}, r_{50}, w_{50}, w_{60}$	Conflict detected at w_{50} . Either abort T_{50} or T_{60} .
6.	$r_{60}, w_{60}, r_{50}, w_{50}$	Conflict detected at w_{50} . Hence, abort T_{50} .

Table 1: Permutations of operations

From this table, it can be seen that when a conflict is detected, in some cases, algorithm *PKTO* must abort T_{50} . In case both the transactions are live, *PKTO* has the option of aborting either transaction depending on their ITS. If T_{60} has lower ITS then in no case, *PKTO* is required to abort T_{60} . In other words, it is possible to ensure that the transaction with lowest ITS and the highest CTS is never aborted. Although in this example, we considered only one t-object, this logic can be extended to cases having multiple operations and t-objects.

Next, consider Step 1b of *PKTO* algorithm. Suppose a transaction T_i wants to read a t-object but does not find a version with a timestamp smaller than i . In this case, T_i has to abort. But if T_i has the highest CTS, then it will certainly find a version to read from. This is because the timestamp of a version corresponds to the timestamp of the transaction that created it. If T_i has the highest CTS value then it implies that all versions of all the t-objects

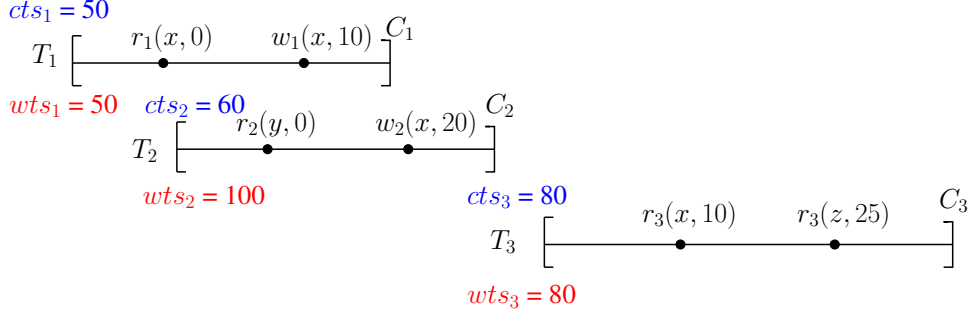

Figure 7: Correctness of SFKTO Algorithm

have a timestamp smaller than CTS of T_i . This reinforces the above observation that a transaction with lowest ITS and highest CTS is not aborted.

To summarize the discussion, algorithm *PKTO* has an in-built mechanism to protect transactions with lowest ITS and highest CTS value. However, this is different from what we need. Specifically, we want to protect a transaction T_i , with lowest *ITS* value. One way to ensure this: if transaction T_i with lowest ITS keeps getting aborted, eventually it will achieve the highest CTS. Once this happens, *PKTO* ensures that T_i cannot be further aborted. In this way, we can ensure the liveness of all transactions.

The working of starvation-free algorithm: To realize this idea and achieve *starvation-freedom*, we consider another variation of MVTO, *Starvation-Free MVTO* or *SFMVTO*. We specifically consider SFMVTO with K versions, denoted as *SFKTO*.

A transaction T_i instead of using the current time as cts_i , uses a potentially higher timestamp, *Working Timestamp - WTS* or wts_i . Specifically, it adds $C * (cts_i - its_i)$ to cts_i , i.e.,

$$wts_i = cts_i + C * (cts_i - its_i); \quad (1)$$

where, C is any constant greater than 0. In other words, when the transaction T_i is issued for the first time, wts_i is same as $cts_i (= its_i)$. However, as transaction keeps getting aborted, the drift between cts_i and wts_i increases. The value of wts_i increases with each retry.

Furthermore, in SFKTO algorithm, CTS is replaced with WTS for *stm-read*, *stm-write* and *stm-tryC* operations of *PKTO*. In SFKTO, a transaction T_i uses wts_i to read a version in *stm-read*. Similarly, T_i uses wts_i in *stm-tryC* to find the appropriate previous version (in Step 1b) and to verify if T_i has to be aborted (in Step 1a). Along the same lines, once T_i decides to commit and create new versions of x , the timestamp of x will be same as its wts_i (in Step 3). Thus the timestamp of all the versions in *vlist* will be WTS of the transactions that created them.

Now, we have the following property about SFKTO algorithm.

Property 6 *SFKTO algorithm ensures starvation-freedom.*

While the proof of this property is somewhat involved, the key idea is that the transaction with lowest ITS value, say T_{low} , will eventually have highest WTS value than all the other transactions in the system. Moreover, after a certain duration, any *new* transaction arriving in the system (i.e., whose *ITS* value sufficiently higher than that of T_{low}) will have a lower *WTS* value than T_{low} . This will ensure that T_{low} will not be aborted. In fact, this property can be shown to be true of SFMVTO as well.

The drawback of SFKTO: Although SFKTO satisfies starvation-freedom, it, unfortunately, does not satisfy strict-serializability. Specifically, it violates the real-time requirement. *PKTO* uses CTS for its working while SFKTO uses WTS. It can be seen that CTS is close to the real-time execution of transactions whereas WTS of a transaction T_i is artificially inflated based on its ITS and might be much larger than its CTS. We illustrate this with an example. Consider the history $H1$ as shown in Fig 7: $r_1(x, 0)r_2(y, 0)w_1(x, 10)$

$C_1w_2(x, 20)C_2r_3(x, 10)r_3(z, 25)C_3$ with CTS as 50, 60 and 80 and WTS as 50, 100 and 80 for T_1, T_2, T_3 respectively. Here T_1, T_2 are ordered before T_3 in real-time with $T_1 \prec_{H1}^{RT} T_3$ and $T_2 \prec_{H1}^{RT} T_3$ although T_2 has a higher WTS than T_3 .

Here, as per SFKTO algorithm, T_3 reads x from T_1 since T_1 has the largest WTS (50) smaller than T_3 's WTS (80). It can be verified that it is possible for SFKTO to generate such a history. But this history is not strict-serializable. The only possible serial order equivalent to $H1$ and legal is $T_1T_3T_2$. But this violates real-time order as T_3 is serialized before T_2 but in $H1$, T_2 completes before T_3 has begun. Since $H1$ is not strict-serializable, it is not locally-opaque as well. Naturally, this drawback extends to SFMVTO as well.

3.6 Design of *KSFTM*: Regaining Correctness while Preserving *Starvation-Freedom*

In this section, we discuss how principles of *PKTO* and *SFKTO* can be combined to obtain *KSFTM* that provides both correctness (strict-serializability and locally-opaque) as well as *starvation-freedom*. To achieve this, we first understand why the initial algorithm, *PKTO* satisfies strict-serializability. This is because CTS was used to create the ordering among committed transactions. CTS is closely associated with real-time. In contrast, *SFKTO* uses WTS which may not correspond to the real-time, as WTS may be significantly larger than CTS as shown by *H1* in Fig 7.

One straightforward way to modify *SFKTO* is to delay a committing transaction, say T_i with WTS value wts_i until the real-time (G_tCntr) catches up to wts_i . This will ensure that value of WTS will also become same as the real-time thereby guaranteeing strict-serializability. However, this is unacceptable, as in practice, it would require transaction T_i locking all the variables it plans to update and wait. This will adversely affect the performance of the STM system.

We can allow the transaction T_i to commit before its wts_i has caught up with the actual time if it does not violate the real-time ordering. Thus, to ensure that the notion of real-time order is respected by transactions in the course of their execution in *SFKTO*, we add extra time constraints. We use the idea of timestamp ranges. This notion of timestamp ranges was first used by Riegel et al. [24] in the context of multi-version STMs. Several other researchers have used this idea since then such as Guerraoui et al. [10], Crain et al. [5], Aydonat & Abdelrahman [1].

Thus, in addition to ITS, CTS and WTS, each transaction T_i maintains a timestamp range: *Transaction Lower Timestamp Limit* or $tltl_i$, and *Transaction Upper Timestamp Limit* or $tutl_i$. When a transaction T_i begins, $tltl_i$ is assigned cts_i and $tutl_i$ is assigned a largest possible value which we denote as infinity. When T_i executes a method m in which it reads a version of a t-object x or creates a new version of x in *stm-tryC*, $tltl_i$ is incremented while $tutl_i$ gets decremented¹.

We require to serialize all the transactions based on their WTS while maintaining their real-time order. On executing m , T_i is ordered w.r.t to other transactions that have created a version of x based on increasing order of WTS. For all transactions T_j which also have created a version of x and whose wts_j is less than wts_i , $tltl_i$ is incremented such that $tutl_j$ is less than $tltl_i$. Note that all such T_j are serialized before T_i . Similarly, for any transaction T_k which has created a version of x and whose wts_k is greater than wts_i , $tutl_i$ is decremented such that it becomes less than $tltl_k$. Again, note that all such T_k is serialized after T_i .

Note that in the above discussion, T_i need not have created a version of x . It could also have read the version of x created by T_j . After the increments of $tltl_i$ and the decrements of $tutl_i$, if $tltl_i$ turns out to be greater than $tutl_i$ then T_i is aborted. Intuitively, this implies that T_i 's WTS and real-time orders are out of *sync* and cannot be reconciled.

Finally, when a transaction T_i commits: (1) T_i records its commit time (or $comTime_i$) by getting the current value of G_tCntr and incrementing it by $incrVal$ which is any value greater than or equal to 1. Then $tutl_i$ is set to $comTime_i$ if it is not already less than it. Now suppose T_i occurs in real-time before some other transaction, T_k but does not have any conflict with it. This step ensures that $tutl_i$ remains less than $tltl_k$ (which is initialized with cts_k); (2) Ensure that $tltl_i$ is still less than $tutl_i$. Otherwise, T_i is aborted.

We illustrate this technique with the history *H1* shown in Fig 7. When T_1 starts its $cts_1 = 50, tltl_1 = 50, tutl_1 = \infty$. Now when T_1 commits, suppose G_tCntr is 70. Hence, $tutl_1$ reduces to 70. Next, when T_2 commits, suppose $tutl_2$ reduces to 75 (the current value of G_tCntr). As T_1, T_2 have accessed a common t-object x in a conflicting manner, $tltl_2$ is incremented to a value greater than $tutl_1$, say 71. Next, when T_3 begins, $tltl_3$ is assigned cts_3 which is 80 and $tutl_3$ is initialized to ∞ . When T_3 reads 10 from T_1 , which is $r_3(x, 10)$, $tutl_3$ is reduced to a value less than $tltl_2 (= 71)$, say 70. But $tltl_3$ is already at 80. Hence, the limits of T_3 have crossed and thus causing T_3 to abort. The resulting history consisting of only committed transactions $T_1 T_2$ is strict-serializable.

Based on this idea, we next develop a variation of *SFKTO*, *K-version Starvation-Free STM System* or *KSFTM*. To explain this algorithm, we first describe the structure of the version of a t-object used. It is a slight variation of the t-object used in *PKTO* algorithm. It consists of: (1) timestamp, ts which is the WTS of the transaction that created this version (and not CTS like *PKTO*); (2) the value of the version; (3) a list, called read-list, consisting of transactions ids (could be CTS as well) that read from this version; (4) version real-time timestamp or vrt which is the $tutl$ of the transaction that created this version. Thus a version has information of WTS and $tutl$ of the transaction that created it.

¹Technically ∞ , which is assigned to $tutl_i$, cannot be decremented. But here as mentioned earlier, we use ∞ to denote the largest possible value that can be represented in a system.

Now, we describe the main idea behind *stm-begin*, *stm-read*, *stm-write* and *stm-tryC* operations of a transaction T_i which is an extension of *PKTO*. Note that as per our notation i represents the CTS of T_i .

stm-begin(t): A unique timestamp ts is allocated to T_i which is its CTS (i from our assumption) which is generated by atomically incrementing the global counter G_tCntr . If the input t is null then $cts_i = its_i = ts$ as this is the first incarnation of this transaction. Otherwise, the non-null value of t is assigned to its_i . Then, WTS is computed by Eq.(1). Finally, $tltl$ and $tutl$ are initialized: $tltl_i = cts_i$, $tutl_i = \infty$.

stm-read(x): Transaction T_i reads from a version of x with timestamp j such that j is the largest timestamp less than wts_i (among the versions x), i.e. there exists no version k such that $j < k < wts_i$ is true. If no such j exists then T_i is aborted. Otherwise, after reading this version of x , T_i is stored in j 's rl . Then we modify $tltl$, $tutl$ as follows:

1. The version $x[j]$ is created by a transaction with wts_j which is less than wts_i . Hence, $tltl_i = \max(tltl_i, x[j].vrt + 1)$.
2. Let p be the timestamp of smallest version larger than i . Then $tutl_i = \min(tutl_i, x[p].vrt - 1)$.
3. After these steps, abort T_i if $tltl$ and $tutl$ have crossed, i.e., $tltl_i > tutl_i$.

stm-write(x, v): T_i stores this write to value x locally in its $wset_i$.

stm-tryC: This operation consists of multiple steps:

1. Before T_i can commit, we need to verify that any version it creates is updated consistently. T_i creates a new version with timestamp wts_i . Hence, we must ensure that any transaction that read a previous version is unaffected by this new version. Additionally, creating this version would require an update of $tltl$ and $tutl$ of T_i and other transactions whose read-write set overlaps with that of T_i . Thus, T_i first validates each t-object x in its $wset$ as follows:

- (a) T_i finds a version of x with timestamp j such that j is the largest timestamp less than wts_i (like in *stm-read*). If there exists no version of x with a timestamp less than wts_i then T_i is aborted. This is similar to Step 1b of the *stm-tryC* of *PKTO* algorithm.
- (b) Among all the transactions that have previously read from j suppose there is a transaction T_k such that $j < wts_i < wts_k$. Then (i) if T_k has already committed then T_i is aborted; (ii) Suppose T_k is live, and its_k is less than its_i . Then again T_i is aborted; (iii) If T_k is still live with its_i less than its_k then T_k is aborted.

This step is similar to Step 1a of the *stm-tryC* of *PKTO* algorithm.

- (c) Next, we must ensure that T_i 's $tltl$ and $tutl$ are updated correctly w.r.t to other concurrently executing transactions. To achieve this, we adjust $tltl$, $tutl$ as follows: (i) Let j be the ts of the largest version smaller than wts_i . Then $tltl_i = \max(tltl_i, x[j].vrt + 1)$. Next, for each reading transaction, T_r in $x[j].read-list$, we again set, $tltl_i = \max(tltl_i, tutl_r + 1)$. (ii) Similarly, let p be the ts of the smallest version larger than wts_i . Then, $tutl_i = \min(tutl_i, x[p].vrt - 1)$. (Note that we don't have to check for the transactions in the read-list of $x[p]$ as those transactions will have $tltl$ higher than $x[p].vrt$ due to *stm-read*.) (iii) Finally, we get the commit time of this transaction from G_tCntr : $comTime_i = G_tCntr.add\&Get(incrVal)$ where $incrVal$ is any constant ≥ 1 . Then, $tutl_i = \min(tutl_i, comTime_i)$. After performing these updates, abort T_i if $tltl$ and $tutl$ have crossed, i.e., $tltl_i > tutl_i$.

2. After performing the tests of Step 1 over each t-objects x in T_i 's $wset$, if T_i has not yet been aborted, we proceed as follows: for each x in $wset_i$ create a $vTuple$ $\langle wts_i, wset_i.x.v, null, tutl_i \rangle$. In this tuple, wts_i is the timestamp of the new version; $wset_i.x.v$ is the value of x in T_i 's $wset$; the read-list of the $vTuple$ is $null$; vrt is $tutl_i$ (actually it can be any value between $tltl_i$ and $tutl_i$). Update the $vlist$ of each t-object x similar to Step 2 of *stm-tryC* of *PKTO*.

3. Transaction T_i is then committed.

Step 1c.(iii) of *stm-tryC* ensures that real-time order between transactions that are not in conflict. It can be seen that locks have to be used to ensure that all these methods to execute in a linearizable manner (i.e., atomically).

3.7 Data Structures and Pseudocode of *KSFTM*

The STM system consists of the following methods: $init()$, $stm-begin()$, $read(i, x)$, $write_i(i, x, v)$ and $stm-tryC(i)$. We assume that all the t-objects are ordered as x_1, x_2, \dots, x_n and belong to the set \mathcal{T} . We describe the data-structures used by the algorithm.

We start with structures that local to each transaction. Each transaction T_i maintains a $rset_i$ and $wset_i$. In addition it maintains the following structures (1) $comTime_i$: This is value given to T_i when it terminates which is assigned a value in $stm-tryC$ method. (2) A series of lists: smallRL, largeRL, allRL, prevVL, nextVL, reLL, abortRL. The meaning of these lists will be clear with the description of the pseudocode. In addition to these local structures, the following shared global structures are maintained that are shared across transactions (and hence, threads). We name all the shared variable starting with ‘G’.

- G_tCntr (counter): This a numerical valued counter that is incremented when a transaction begins and terminates.

For each transaction T_i we maintain the following shared time-stamps:

- G_lock_i : A lock for accessing all the shared variables of T_i .
- G_its_i (initial timestamp): It is a time-stamp assigned to T_i when it was invoked for the first time without any aborts. The current value of G_tCntr is atomically assigned to it and then incremented. If T_i is aborted and restarts later then the application assigns it the same G_its.
- G_cts_i (current timestamp): It is a time-stamp when T_i is invoked again at a later time after an abort. Like G_its, the current value of G_tCntr is atomically assigned to it and then incremented. When T_i is created for the first time, then its G_cts is same as its G_its.
- G_wts_i (working timestamp): It is the time-stamp that T_i works with. It is either greater than or equal to T_i 's G_cts. It is computed as follows: $G_wts_i = G_cts_i + C * (G_cts_i - G_its_i)$.
- G_valid_i : This is a boolean variable which is initially true. If it becomes false then T_i has to be aborted.
- G_state_i : This is a variable which states the current value of T_i . It has three states: live, committed or aborted.
- G_tttl_i, G_tutl_i (transaction lower & upper time limits): These are the time-limits described in the previous section used to keep the transaction WTS and real-time orders in sync. G_tttl_i is G_cts of T_i when transaction begins and is a non-decreasing value. It continues to increase (or remains same) as T_i reads t-objects and later terminates. G_tutl_i on the other hand is a non-increasing value starting with ∞ when the T_i is created. It reduces (or remains same) as T_i reads t-objects and later terminates. If T_i commits then both G_tttl_i & G_tutl_i are made equal.

Two transactions having the same ITS are said to be incarnations. No two transaction can have the same CTS. For simplicity, we assume that no two transactions have the same WTS as well. In case, two transactions have the same WTS, one can use the tuple $\langle WTS, CTS \rangle$ instead of WTS. But we ignore such cases. For each t-object x in \mathcal{T} , we maintain:

- $x.vl$ (version list): It is a list consisting of version tuples or $vTuple$ of the form $\langle ts, val, rl, vrt \rangle$. The details of the tuple are explained below.
- ts (timestmp): Here ts is the G_wts_i of a committed transaction T_i that has created this version.
- val : The value of this version.
- rl (readList): rl is the read list consists of all the transactions that have read this version. Each entry in this list is of the form $\langle rts \rangle$ where rts is the G_wts_j of a transaction T_j that read this version.
- vrt (version real-time timestamp): It is the G_tutl value (which is same as G_tttl) of the transaction T_i that created this version at the time of commit of T_i .

Algorithm 16 STM *init()*: Invoked at the start of the STM system. Initializes all the t-objects used by the STM System

```

1:  $G\_tCntr = 1$ ; /* Global Transaction Counter */
2: for all  $x$  in  $\mathcal{T}$  do /* All the t-objects used by the STM System */
3:   /*  $T_0$  is creating the first version of  $x$ :  $ts = 0, val = 0, rl = nil, vrt = 0$  */
4:   add  $\langle 0, 0, nil, 0 \rangle$  to  $x.vl$ ;
5: end for;

```

Algorithm 17 STM *stm-begin(its)*: Invoked by a thread to start a new transaction T_i . Thread can pass a parameter *its* which is the initial timestamp when this transaction was invoked for the first time. If this is the first invocation then *its* is *nil*. It returns the tuple $\langle id, G_wts, G_cts \rangle$

```

1:  $i = \text{unique-id}$ ; /* An unique id to identify this transaction. It could be same as  $G\_cts$  */
2: /* Initialize transaction specific local & global variables */
3: if ( $its == nil$ ) then
4:    $G\_its_i = G\_wts_i = G\_cts_i = G\_tCntr.get\&Inc()$ ; /*  $G\_tCntr.get\&Inc()$  returns the current value of  $G\_tCntr$  and atomically increments it */
5: else
6:    $G\_its_i = its$ ;
7:    $G\_cts_i = G\_tCntr.get\&Inc()$ ;
8:    $G\_wts_i = G\_cts_i + C * (G\_cts_i - G\_its_i)$ ; /*  $C$  is any constant greater or equal to than 1 */
9: end if
10:  $G\_ttl_i = G\_cts_i$ ;  $G\_ttl_i = comTime_i = \infty$ ;
11:  $G\_state_i = \text{live}$ ;  $G\_valid_i = T$ ;
12:  $rset_i = wset_i = nil$ ;
13: return  $\langle i, G\_wts_i, G\_cts_i \rangle$ 

```

Algorithm 18 STM *read(i, x)*: Invoked by a transaction T_i to read t-object x . It returns either the value of x or \mathcal{A}

```

1: if ( $x \in wset_i$ ) then /* Check if the t-object  $x$  is in  $wset_i$  */
2:   return  $wset_i[x].val$ ;
3: else if ( $x \in rset_i$ ) then /* Check if the t-object  $x$  is in  $rset_i$  */
4:   return  $rset_i[x].val$ ;
5: else /* t-object  $x$  is not in  $rset_i$  and  $wset_i$  */
6:   lock  $x$ ; lock  $G\_lock_i$ ;
7:   if ( $G\_valid_i == F$ ) then return abort(i);
8:   end if
9:   /* findLTS: From  $x.vl$ , returns the largest  $ts$  value less than  $G\_wts_i$ . If no such version exists, it returns  $nil$  */
10:   $curVer = \text{findLTS}(G\_wts_i, x)$ ;
11:  if ( $curVer == nil$ ) then return abort(i); /* Proceed only if  $curVer$  is not  $nil$  */
12:  end if
13:  /* findSTL: From  $x.vl$ , returns the smallest  $ts$  value greater than  $G\_wts_i$ . If no such version exists, it returns  $nil$  */
14:   $nextVer = \text{findSTL}(G\_wts_i, x)$ ;

```

```

15: if ( $nextVer \neq nil$ ) then
16:     /* Ensure that  $G\_ttl_i$  remains smaller than  $nextVer$ 's  $vrt$  */
17:      $G\_ttl_i = \min(G\_ttl_i, x[nextVer].vrt - 1)$ ;
18: end if
19: /*  $G\_ttl_i$  should be greater than  $x[curVer].vrt$  */
20:  $G\_ttl_i = \max(G\_ttl_i, x[curVer].vrt + 1)$ ;
21: if ( $G\_ttl_i > G\_tutl_i$ ) then /* If the limits have crossed each other, then  $T_i$  is aborted */
22:     return abort( $i$ );
23: end if
24:  $val = x[curVer].v$ ; add  $\langle x, val \rangle$  to  $rset_i$ ;
25: add  $T_i$  to  $x[curVer].rl$ ;
26: unlock  $G\_lock_i$ ; unlock  $x$ ;
27: return  $val$ ;
28: end if

```

Algorithm 19 STM $write_i(x, val)$: A Transaction T_i writes into local memory

```

1: Append the  $d\_tuple\langle x, val \rangle$  to  $wset_i$ .
2: return  $ok$ ;

```

Algorithm 20 STM $stm_tryC()$: Returns ok on commit else return Abort

```

1: /* The following check is an optimization which needs to be performed again later */
2: lock  $G\_lock_i$ ;
3: if ( $G\_valid_i == F$ ) then return abort( $i$ );
4: end if
5: unlock  $G\_lock_i$ ;
6: /* Initialize smaller read list (smallRL), larger read list (largeRL), all read list (allRL) to nil */
7:  $smallRL = largeRL = allRL = nil$ ;
8: /* Initialize previous version list (prevVL), next version list (nextVL) to nil */
9:  $prevVL = nextVL = nil$ ;
10: for all  $x \in wset_i$  do
11:     lock  $x$  in pre-defined order;
12:     /* findLTS: returns the version of  $x$  with the largest  $ts$  less than  $G\_wts_i$ . If no such version exists, it
        returns  $nil$ . */
13:      $prevVer = findLTS(G\_wts_i, x)$ ; /* prevVer: largest version smaller than  $G\_wts_i$  */
14:     if ( $prevVer == nil$ ) then /* There exists no version with  $ts$  value less than  $G\_wts_i$  */
15:         lock  $G\_lock_i$ ; return abort( $i$ );
16:     end if
17:      $prevVL = prevVL \cup prevVer$ ; /* prevVL stores the previous version in sorted order */
18:      $allRL = allRL \cup x[prevVer].rl$ ; /* Store the read-list of the previous version */
19:     /* getLar: obtain the list of reading transactions of  $x[prevVer].rl$  whose  $G\_wts$  is greater than  $G\_wts_i$ 
        */
20:      $largeRL = largeRL \cup getLar(G\_wts_i, x[prevVer].rl)$ ;
21:     /* getSm: obtain the list of reading transactions of  $x[prevVer].rl$  whose  $G\_wts$  is smaller than  $G\_wts_i$ 
        */
22:      $smallRL = smallRL \cup getSm(G\_wts_i, x[prevVer].rl)$ ;

```

Algorithm 21 $isAborted(T_k)$: Verifies if T_i is already aborted or its G_valid flag is set to false implying that T_i will be aborted soon

```

1: if ( $G\_valid_k == F$ )  $\vee$  ( $G\_state_k == abort$ )  $\vee$  ( $T_k \in abortRL$ ) then
2:     return  $T$ ;
3: else
4:     return  $F$ ;
5: end if

```

```

23:  /* findSTL: returns the version with the smallest  $t_s$  value greater than  $G_{wts_i}$ . If no such version exists,
    it returns  $nil$ . */
24:   $nextVer = findSTL(G_{wts_i}, x)$ ; /*  $nextVer$ : smallest version larger than  $G_{wts_i}$  */
25:  if ( $nextVer \neq nil$ ) then
26:       $nextVL = nextVL \cup nextVer$ ; /*  $nextVL$  stores the next version in sorted order */
27:  end if
28: end for /*  $x \in wset_i$  */
29:  $relLL = allRL \cup T_i$ ; /* Initialize relevant Lock List ( $relLL$ ) */
30: for all ( $T_k \in relLL$ ) do
31:     lock  $G_{lock_k}$  in pre-defined order; /* Note: Since  $T_i$  is also in  $relLL$ ,  $G_{lock_i}$  is also locked */
32: end for
33: /* Verify if  $G_{valid_i}$  is false */
34: if ( $G_{valid_i} == F$ ) then return abort(i);
35: end if
36:  $abortRL = nil$  /* Initialize abort read list ( $abortRL$ ) */
37: /* Among the transactions in  $T_k$  in  $largeRL$ , either  $T_k$  or  $T_i$  has to be aborted */
38: for all ( $T_k \in largeRL$ ) do
39:     if ( $isAborted(T_k)$ ) then
40:         /* Transaction  $T_k$  can be ignored since it is already aborted or about to be aborted */
41:         continue;
42:     end if
43:     if ( $G_{its_i} < G_{its_k}$ )  $\wedge$  ( $G_{state_k} == live$ ) then
44:         /* Transaction  $T_k$  has lower priority and is not yet committed. So it needs to be aborted */
45:          $abortRL = abortRL \cup T_k$ ; /* Store  $T_k$  in  $abortRL$  */
46:     else /* Transaction  $T_i$  has to be aborted */
47:         return abort(i);
48:     end if
49: end for
50: /* Ensure that  $G_{ttl_i}$  is greater than  $vrt$  of the versions in  $prevVL$  */
51: for all ( $ver \in prevVL$ ) do
52:      $x = t\text{-object of } ver$ ;
53:      $G_{ttl_i} = \max(G_{ttl_i}, x[ver].vrt + 1)$ ;
54: end for
55: /* Ensure that  $vutl_i$  is less than  $vrt$  of versions in  $nextVL$  */
56: for all ( $ver \in nextVL$ ) do
57:      $x = t\text{-object of } ver$ ;
58:      $G_{tutl_i} = \min(G_{tutl_i}, x[ver].vrt - 1)$ ;
59: end for
60: /* Store the current value of the global counter as commit time and increment it */
61:  $comTime_i = G_{tCntr.add\&Get(incrVal)}$ ; /*  $incrVal$  can be any constant  $\geq 1$  */
62:  $G_{tutl_i} = \min(G_{tutl_i}, comTime_i)$ ; /* Ensure that  $G_{tutl_i}$  is less than or equal to  $comTime$  */
63: /* Abort  $T_i$  if its limits have crossed */
64: if ( $G_{ttl_i} > G_{tutl_i}$ ) then return abort(i);
65: end if

```

```

66: for all ( $T_k \in smallRL$ ) do
67:   if ( $isAborted(T_k)$ ) then
68:     continue;
69:   end if
70:   if ( $G\_ttl_k \geq G\_tutl_i$ ) then /* Ensure that the limits do not cross for both  $T_i$  &  $T_k$  */
71:     if ( $G\_state_k == live$ ) then /* Check if  $T_k$  is live */
72:       if ( $G\_its_i < G\_its_k$ ) then
73:         /* Transaction  $T_k$  has lower priority and is not yet committed. So it needs to be aborted */
74:          $abortRL = abortRL \cup T_k$ ; /* Store  $T_k$  in abortRL */
75:       else /* Transaction  $T_i$  has to be aborted */
76:         return abort(i);
77:       end if /* ( $G\_its_i < G\_its_k$ ) */
78:       else /* ( $T_k$  is committed. Hence,  $T_i$  has to be aborted) */
79:         return abort(i);
80:       end if /* ( $G\_state_k == live$ ) */
81:     end if /* ( $G\_ttl_k \geq G\_tutl_i$ ) */
82:   end for ( $T_k \in smallRL$ )
83:   /* After this point  $T_i$  can't abort. */
84:    $G\_ttl_i = G\_tutl_i$ ;
85:   /* Since  $T_i$  can't abort, we can update  $T_k$ 's  $G\_tutl$  */
86:   for all ( $T_k \in smallRL$ ) do
87:     if ( $isAborted(T_k)$ ) then
88:       continue;
89:     end if
90:     /* The following line ensure that  $G\_ttl_k \leq G\_tutl_k < G\_ttl_i$ . Note that this does not cause the limits of
       $T_k$  to cross each other because of the check in Line 70.*/
91:      $G\_tutl_k = \min(G\_tutl_k, G\_ttl_i - 1)$ ;
92:   end for
93:   for all  $T_k \in abortRL$  do /* Abort all the transactions in abortRL since  $T_i$  can't abort */
94:      $G\_valid_k = F$ ;
95:   end for
96:   /* Having completed all the checks,  $T_i$  can be committed */
97:   for all ( $x \in wset_i$ ) do
98:     /* Create new  $v\_tuple$ :  $ts, val, rl, vrt$  for  $x$  */
99:      $newTuple = \langle G\_wts_i, wset_i[x].val, nil, G\_ttl_i \rangle$ ;
100:    if ( $|x.vl| > k$ ) then
101:      replace the oldest tuple in  $x.vl$  with  $newTuple$ ; /*  $x.vl$  is ordered by  $ts$  */
102:    else
103:      add a  $newTuple$  to  $x.vl$  in sorted order;
104:    end if
105:  end for /*  $x \in wset_i$  */
106:   $G\_state_i = commit$ ;
107:  unlock all variables;
108:  return  $\mathcal{C}$ ;

```

Algorithm 22 *abort(i)*: Invoked by various STM methods to abort transaction T_i . It returns \mathcal{A}

- 1: $G_valid_i = F; G_state_i = \text{abort};$
 - 2: unlock all variables locked by T_i ;
 - 3: return \mathcal{A} ;
-

We get the following nice properties on *KSFTM*. For simplicity, we assumed C and $incrVal$ to be 0.1 and 1 respectively in our analysis. But the proof and the analysis holds for any value greater than 0.

Theorem 7 Any history generated by *KSFTM* is strict-serializable and locally-opaque.

Theorem 8 *KSFTM* algorithm ensures starvation-freedom.

As explained in the description Property 6, the proof of this property is somewhat involved. As expected, this proof can be extended to *UVSFTM* as well.

Garbage Collection: Having described the *starvation-free* algorithm, we now describe how garbage collection can be performed on the unbounded variant, *UVSFTM* to achieve *UVSFTM-GC*. This is achieved by deleting non-latest version (i.e., there exists a version with greater ts) of each t-object whose timestamp, ts is less than the CTS of smallest live transaction. It must be noted that *UVSFTM (KSFTM)* works with WTS which is greater or equal to CTS for any transaction. Interestingly, the same garbage collection principle can be applied for *PMVTO* to achieve *PMVTO-GC*.

To identify the transaction with the smallest CTS among live transactions, we maintain a set of all the live transactions, *live-list*. When a transaction T_i begins, its CTS is added to this *live-list*. And when T_i terminates (either commits or aborts), T_i is deleted from this *live-list*.

4 Experimental Evaluation

For performance evaluation of *KSFTM* with the state-of-the-art STMs, we implemented the the algorithms *PKTO*, *SV-SFTM* [9, 27, 26] along with *KSFTM* in C++². We used the available implementations of NOrec STM [6], and ESTM [7] developed in C++. Although, only *KSFTM* and *SV-SFTM* provide starvation-freedom, we compared with other STMs as well, to see its performance in practice.

Experimental system: The experimental system is a 2-socket Intel(R) Xeon(R) CPU E5-2690 v4 @ 2.60GHz with 14 cores per socket and 2 hyper-threads (HTs) per core, for a total of 56 threads. Each core has a private 32KB L1 cache and 256 KB L2 cache. The machine has 32GB of RAM and runs Ubuntu 16.04.2 LTS. In our implementation, all threads have the same base priority and we use the default Linux scheduling algorithm. This satisfies the Assumption 1 (bounded-termination) about the scheduler. We ensured that there no parasitic transactions [3] in our experiments.

Methodology: Here we have considered two different applications:(1) Counter application - In this, each thread invokes a single transaction which performs 10 reads/writes operations on randomly chosen t-objects. A thread continues to invoke a transaction until it successfully commits. To obtain high contention, we have taken large number of threads ranging from 50-250 where each thread performs its read/write operation over a set of 5 t-objects. We have performed our tests on three workloads stated as: (W1) Li - Lookup intensive: 90% read, 10% write, (W2) Mi - Mid intensive: 50% read, 50% write and (W3) Ui - Update intensive: 10% read, 90% write. This application is undoubtedly very flexible as it allows us to examine performance by tweaking different parameters (refer to SubSection 4.1 for details). (2) Two benchmarks from STAMP suite [21] - (a) We considered KMEANS which has low contention with short running transactions. The number of data points as 2048 with 16 dimensions and total clusters as 5. (b) We then considered LABYRINTH which has high contention with long running transactions. We considered the grid size as 64x64x3 and paths to route as 48.

To study starvation in the various algorithms, we considered *max-time*, which is the maximum time taken by a transaction among all the transactions in a given experiment to commit from its first invocation. This includes time taken by all the aborted incarnations of the transaction to execute as well. To reduce the effect of outliers, we took the average of max-time in ten runs as the final result for each application.

Results Analysis: Fig 8 illustrates max-time analysis of *KSFTM* over the above mentioned STMs for the counters application under the workloads $W1$, $W2$ and $W3$ while varying the number of threads from 50 to 250. For *KSFTM* and *PKTO*, we chose the value of K as 5 and C as 0.1 as the best results were obtained with these

²Code is available here: <https://github.com/PDCRL/KSFTM>

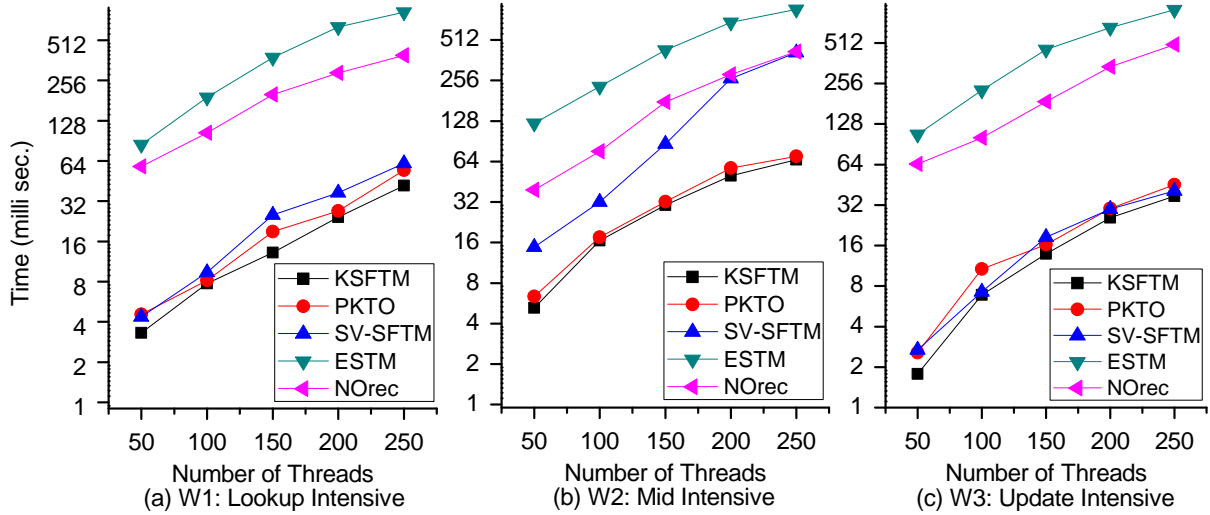

Figure 8: Performance analysis on workload $W1$, $W2$, $W3$

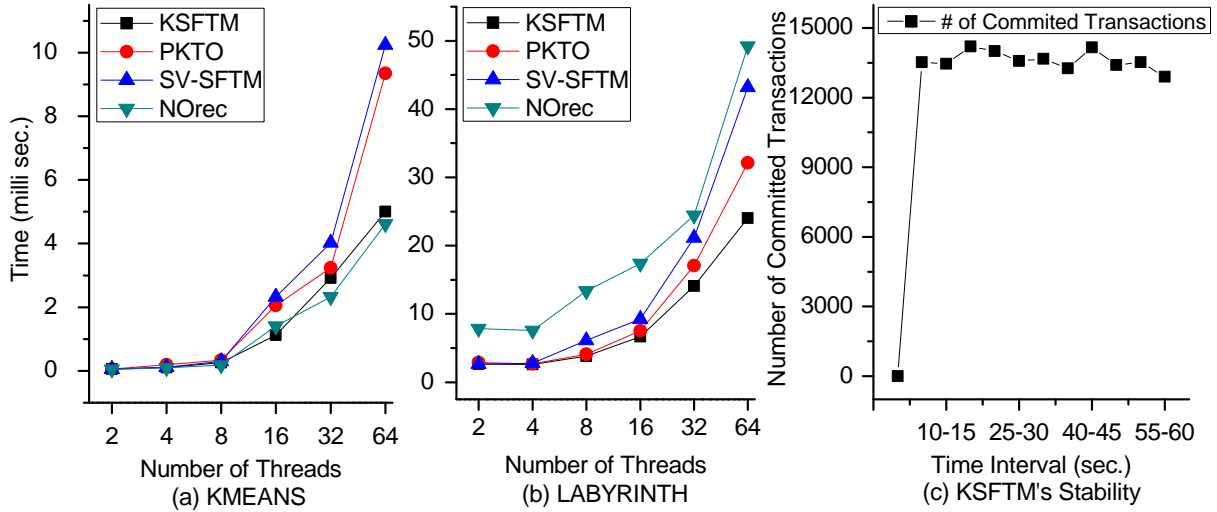

Figure 9: Performance analysis on KMEANS, LABYRINTH and KSFTM's Stability

parameters. We can see that *KSFTM* performs the best for all the three workloads. *KSFTM* gives an average speedup on max-time by a factor of 1.22, 1.89, 23.26 and 13.12 over *PKTO*, *SV-SFTM*, *NOrec* STM and *ESTM* respectively.

Fig 9(a) shows analysis of max-time for KMEANS while Fig 9(b) shows for LABYRINTH. In this analysis we have not considered *ESTM* as the integrated STAMP code for *ESTM* is not publicly available. For KMEANS, *KSFTM* performs 1.5 and 1.44 times better than *PKTO* and *SV-SFTM*. But, *NOrec* is performing 1.09 times better than *KSFTM*. This is because KMEANS has short running transactions have low contention. As a result, the commit time of the transactions is also low.

On the other hand for LABYRINTH, *KSFTM* again performs the best. It performs 1.14, 1.4 and 2.63 times better than *PKTO*, *SV-SFTM* and *NOrec* respectively. This is because LABYRINTH has high contention with long running transactions. This result in longer commit times for transactions.

Fig 9(c) shows the stability of *KSFTM* algorithm over time for the counter application. Here we fixed the number of threads to 32, K as 5, C as 0.1, t -objects as 1000, along with 5 seconds warm-up period on $W1$ workload. Each thread invokes transactions until its time-bound of 60 seconds expires. We performed the experiments on number of transactions committed over time in the increments 5 seconds. The experiment shows that over time *KSFTM* is stable which helps to hold the claim that *KSFTM*'s performance will continue in same manner if time is increased to higher orders.

Maintaining multiple versions to increase the performance and to decrease the number of aborts, leads to

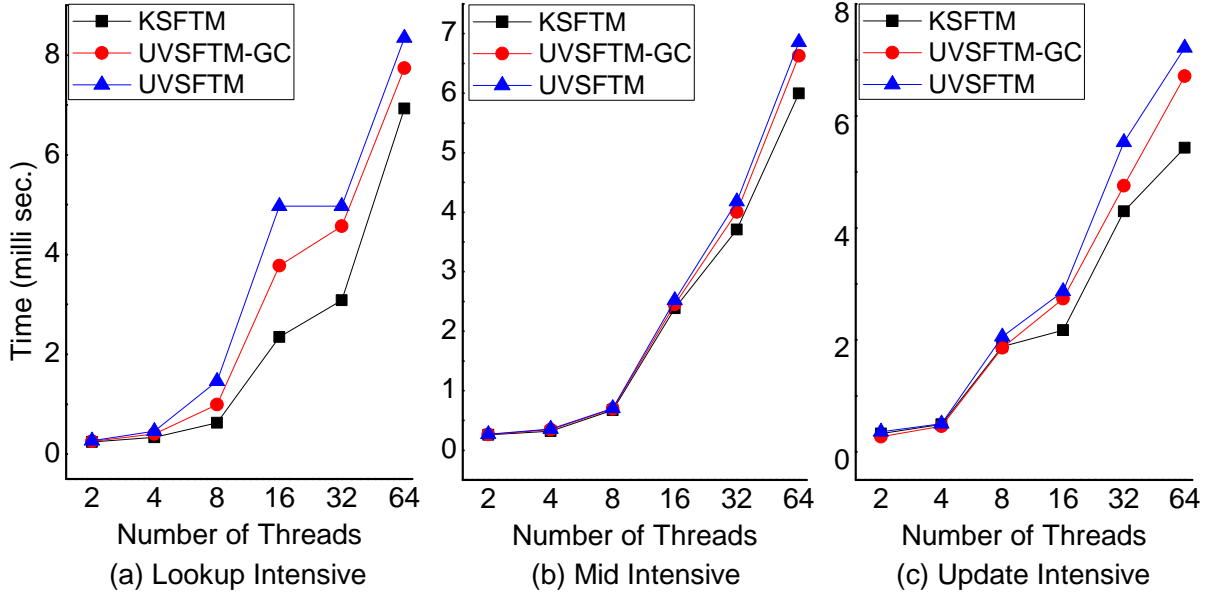

Figure 10: Time comparison among variants of *KSFTM*

creating too many versions which are not of any use and hence occupying space. So, such garbage versions need to be taken care of. Hence we come up with a garbage collection over these unwanted versions. This technique help to conserve memory space and increases the performance in turn as no more unnecessary traversing of garbage versions by transactions is necessary. We have used a global, i.e., across all transactions a list that keeps track of all the live transactions in the system. We call this list as *live-list*. Each transaction at the beginning of its life cycle creates its entry in this *live-list*. Under the optimistic approach of STM, each transaction in the shared memory performs its updates in the *stm-tryC* phase. In this phase, each transaction performs some validations, and if all the validations are successful then the transaction make changes or in simple terms creates versions of the corresponding t-object in the shared memory. While creating a version every transaction, check if it is the least timestamp live transaction present in the system by using *live-list* data structure, if yes then the current transaction deletes all the version of that t-object and create one of its own. Else the transaction does not do any garbage collection or delete any version and look for creating a new version of next t-object in the write set, if at all.

Fig 10 represents three variants of *KSFTM* (*UVSFTM*, *UVSFTM-GC*, and *KSFTM*) and Fig 11 shows the three variants of *PKTO* (*PMVTO*, *PMVTO-GC*, and *PKTO*) on all the workloads *W1* *W2* and *W3*. *KSFTM* outperforms *UVSFTM* and *UVSFTM-GC* by a factor of 2.1 and 1.5. Similarly, *PKTO* outperforms *PMVTO* and *PMVTO-GC* by a factor of 2 and 1.35. These results show that maintaining finite versions corresponding to each t-object performs better than maintaining infinite versions and garbage collection on infinite versions corresponding to each t-object.

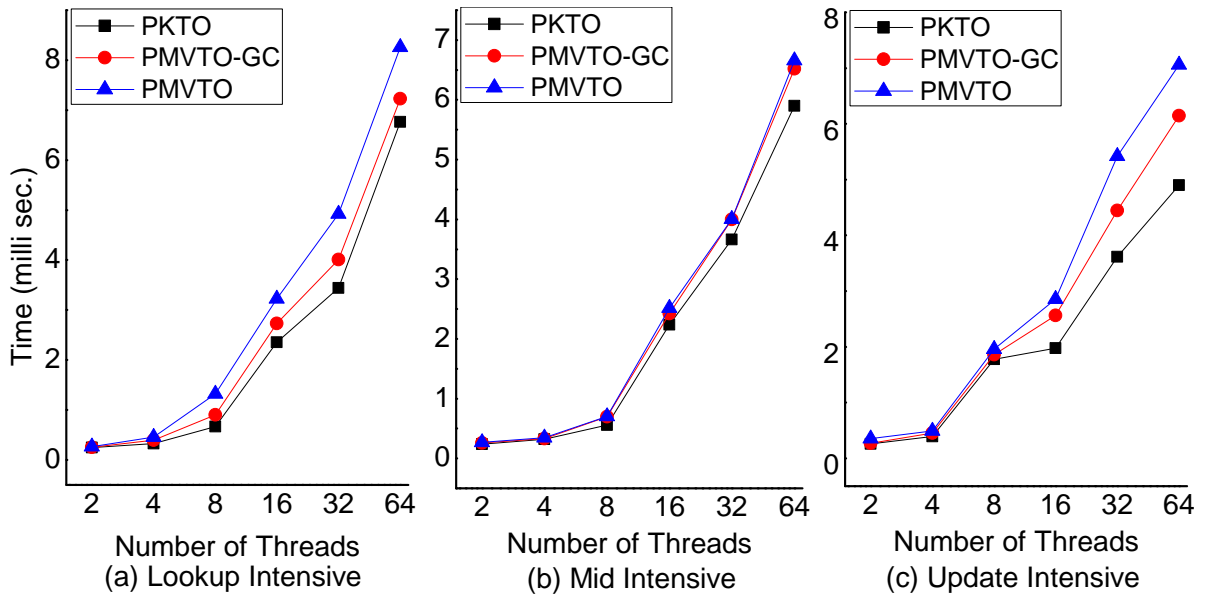

Figure 11: Time comparison among variants of *PKTO*

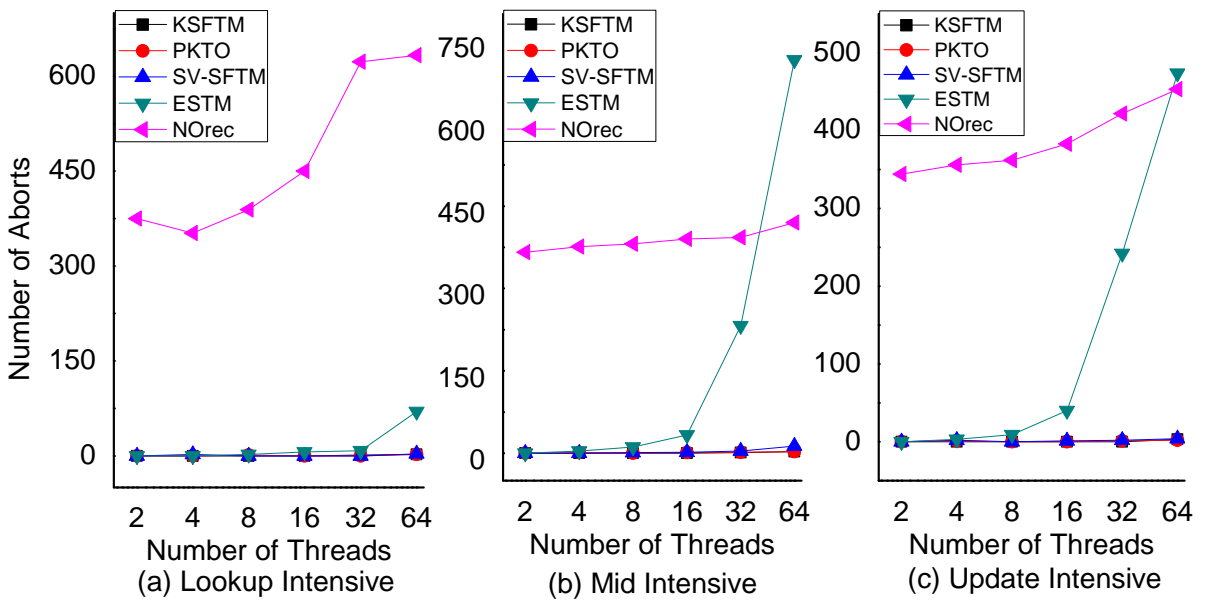

Figure 12: Abort Count on workload W_1, W_2, W_3

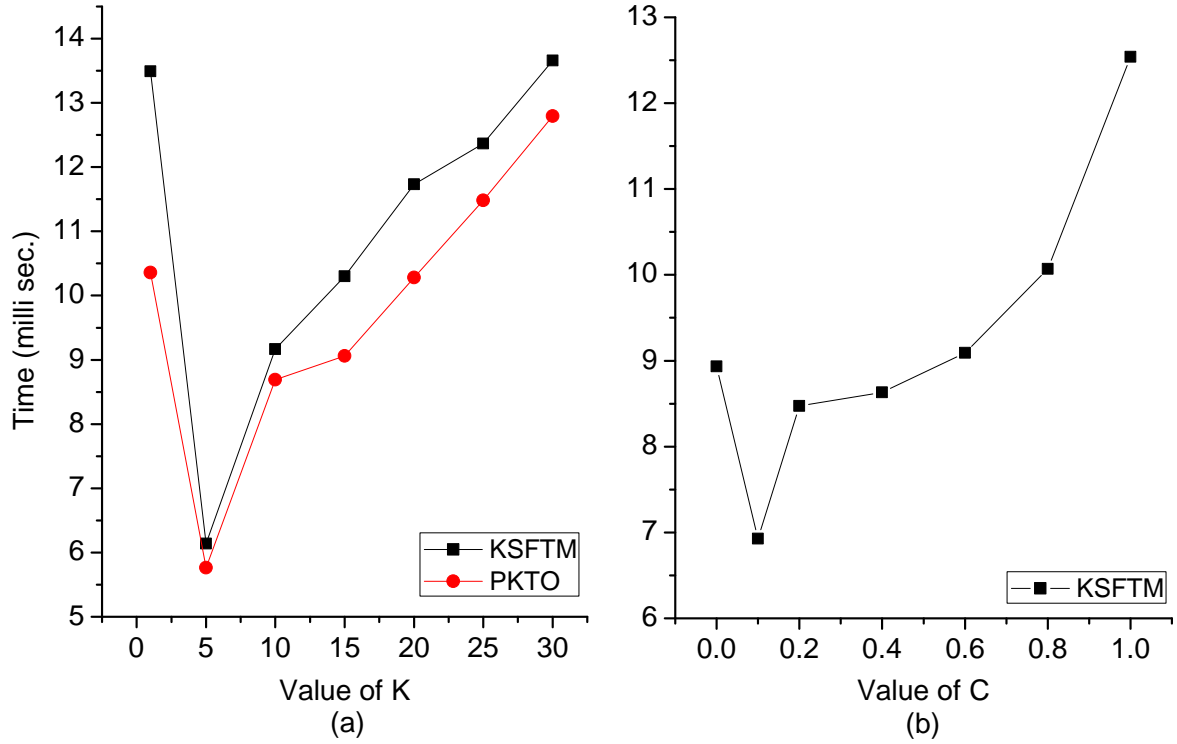

Figure 13: Best value of K and optimal value of C for *KSFTM*

Comparison on the basis of Abort count: Fig 12 shows the abort count comparisons of *KSFTM* with *PKTO*, *ESTM*, *NOfec*, *MVTO*, and *SV-SFTM* across all workloads (*W1*, *W2*, and *W3*). The number of aborts in *ESTM* and *NOfec* are high as compared to all other STM algorithms while all other algorithms (*KSFTM*, *PKTO*, *MVTO*, *SV-SFTM*) have marginally small differences among them.

Best value of K and optimal value of constant C: To identify the best value of K for *KSFTM*, we ran our experiment, varying value of K and keeping the number of threads as 64 on workload *W1* and obtained the optimal value of K in *KSFTM* is 5 as shown in Fig 13.(a) for counter application. Similarly, we calculate the best value of K as 5 for *PKTO* on the same parameters. C, is a constant that is used to calculate *WTS* of a transaction. i.e., $wts_i = cts_i + C * (cts_i - its_i)$; where, C is any constant greater than 0. We run our experiments across load *W1*, for 64 threads and other parameters are same as defined in the methodology of Section 4, we achieve the best value of C as 0.1 for counter application. Experimental results are shown in Fig 13 (b).

4.1 Pseudo code of Counter Application

OP_LT_SEED is defined as number of operations per transaction, *T_OBJ_SEED* is defined as number of transaction objects in the system, *TRANS_LT* defines the total number of transactions to be executed in the system, and *READ_PER* is the percentage of read operation which is used to define various workloads.

Algorithm 24 *testFunc_helper()*:Function invoked by threads

```

1: transaction_count = 0
2: while (TRANS_LT) do
3:   /* Log the time at the start of every transaction */
4:   begin_time = time_request()
5:   /* Invoke the test function to execute a transaction */
6:   abort_count[thread_id] = test_function()
7:   transaction_count ++

```

Algorithm 23 *main()*: The main procedure invoked by counter application

```
1: /* To log abort counts by each thread */
2: abort_count[NUMTHREADS]
3: /* To log average time taken by each transaction to commit */
4: time_taken[NUMTHREADS]
5: /* To log the time of longest running transaction by each thread, worst case time */
6: worst_time[NUMTHREADS]
7: for (i = 0 : NUMTHREADS) do
8:     pthread_create(&threads[i], NULL, testFunc_helper,(void*)args)
9: end for
10: for (i = 0 : NUMTHREADS) do
11:     pthread_join(threads[i], &status)
12: end for
13: max_worst_time = 0.0
14: total_abort_count = 0
15: average_time_taken = 0
16: for (i = 0 : NUMTHREADS) do
17:     if (max_worst_time < worst_time[i]) then
18:         max_worst_time = worst_time[i]
19:     end if
20:     total_abort_count+ = abort_count[i]
21:     average_time_taken+ = time_taken[i]
22: end for
```

```
8: /* Log the time at the end of every transaction */
9: end_time = time_request()
10: time_taken[thread_id]+ = (end_time - begin_time)
11: if (worst_time[thread_id] < (end_time - begin_time)) then
12:     worst_time[thread_id] = (end_time - begin_time)
13: end if
14: TRANS_LT -= 1
15: end while
16: time_taken[thread_id] /= transaction_count
```

Algorithm 25 *test_function()*:main test function while executes a transaction

```
1: Transaction *T = new Transaction;
2:  $T \rightarrow g\_its = NIL$ 
3:  $local\_abort\_count = 0$ 
4: label:
5: while (true) do
6:   if ( $T \rightarrow g\_its \neq NIL$ ) then
7:      $its = T \rightarrow g\_its$ 
8:      $T = lib \rightarrow stm\_begin(its)$ 
9:   else
10:     $T = lib \rightarrow stm\_begin(T \rightarrow g\_its)$ 
11:   end if
12:   for all (OP_LT_SEED) do
13:      $t\_obj = rand()\%T\_OBJ\_SEED$ 
14:      $randVal = rand()\%OP\_SEED$ 
15:     if ( $randVal \leq READ\_PER$ ) then
16:        $stm\_read(t\_obj, value)$ 
17:       if ( $value == ABORTED$ ) then
18:          $local\_abort\_count++$ 
19:         goto label
20:       end if
21:     else
22:        $stm\_write(t\_obj, value)$ 
23:     end if
24:   end for
25:   if ( $lib \rightarrow stm\_tryC() == ABORTED$ ) then
26:      $local\_abort\_count++$ 
27:     continue
28:   end if
29:   break
30: end while
```

5 Graph Characterization of Local Opacity & KSFTM Correctness

To prove correctness of STM systems, it is useful to consider graph characterization of histories. In this section, we describe the graph characterization developed by Kumar et al [17] for proving opacity which is based on characterization by Bernstein and Goodman [2]. We extend this characterization for LO.

Consider a history H which consists of multiple versions for each t-object. The graph characterization uses the notion of *version order*. Given H and a t-object x , we define a version order for x as any (non-reflexive) total order on all the versions of x ever created by committed transactions in H . It must be noted that the version order may or may not be the same as the actual order in which the version of x are generated in H . A version order of H , denoted as \ll_H is the union of the version orders of all the t-objects in H .

Consider the history $H2 : r_1(x, 0)r_2(x, 0)r_1(y, 0)r_3(z, 0)w_1(x, 5)w_3(y, 15)w_2(y, 10)w_1(z, 10)c_1c_2r_4(x, 5)r_4(y, 10)w_3(z, 15)c_3r_4(z, 10)$. Using the notation that a committed transaction T_i writing to x creates a version x_i , a possible version order for $H2 \ll_{H2}$ is: $\langle x_0 \ll x_1 \rangle, \langle y_0 \ll y_2 \ll y_3 \rangle, \langle z_0 \ll z_1 \ll z_3 \rangle$.

We define the graph characterization based on a given version order. Consider a history H and a version order \ll . We then define a graph (called opacity graph) on H using \ll , denoted as $OPG(H, \ll) = (V, E)$. The vertex set V consists of a vertex for each transaction T_i in \overline{H} . The edges of the graph are of three kinds and are defined as follows:

1. *real-time*(real-time) edges: If T_i commits before T_j starts in H , then there is an edge from v_i to v_j . This set of edges are referred to as $rt(H)$.
2. *rf*(reads-from) edges: If T_j reads x from T_i in H , then there is an edge from v_i to v_j . Note that in order for this to happen, T_i must have committed before T_j and $c_i <_H r_j(x)$. This set of edges are referred to as

$rf(H)$.

3. *mv*(multiversion) edges: The *mv* edges capture the multiversion relations and is based on the version order. Consider a successful read operation $r_k(x, v)$ and the write operation $w_j(x, v)$ belonging to transaction T_j such that $r_k(x, v)$ reads x from $w_j(x, v)$ (it must be noted T_j is a committed transaction and $c_j <_H r_k$). Consider a committed transaction T_i which writes to x , $w_i(x, u)$ where $u \neq v$. Thus the versions created x_i, x_j are related by \ll . Then, if $x_i \ll x_j$ we add an edge from v_i to v_j . Otherwise ($x_j \ll x_i$), we add an edge from v_k to v_i . This set of edges are referred to as $mv(H, \ll)$.

Using the construction, the $OPG(H2, \ll_{H2})$ for history $H2$ and \ll_{H2} is shown in Fig 14. The edges are annotated. The only *mv* edge from $T4$ to $T3$ is because of t-objects y, z . $T4$ reads value 5 for z from $T1$ whereas $T3$ also writes 15 to z and commits before $r_4(z)$.

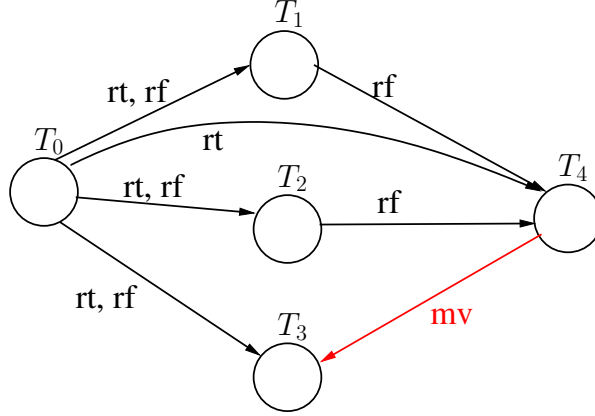

Figure 14: $OPG(H2, \ll_{H2})$

Kumar et al [17] showed that if a version order \ll exists for a history H such that $OPG(H, \ll_H)$ is acyclic, then H is opaque. This is captured in the following result.

Result 9 A valid history H is opaque iff there exists a version order \ll_H such that $OPG(H, \ll_H)$ is acyclic.

This result can be easily extended to prove LO as follows

Theorem 10 A valid history H is locally-opaque iff for each sub-history sh in $H.subhistSet$ there exists a version order \ll_{sh} such that $OPG(sh, \ll_{sh})$ is acyclic. Formally, $((H \text{ is locally-opaque}) \Leftrightarrow (\forall sh \in H.subhistSet, \exists \ll_{sh}: OPG(sh, \ll_{sh}) \text{ is acyclic}))$.

Proof. To prove this theorem, we have to show that each sub-history sh in $H.subhistSet$ is valid. Then the rest follows from Result 9. Now consider a sub-history sh . Consider any read operation $r_i(x, v)$ of a transaction T_i . It is clear that T_i must have read a version of x created by a previously committed transaction. From the construction of sh , we get that all the transaction that committed before r_i are also in sh . Hence sh is also valid.

Now, proving sh to be opaque iff there exists a version order \ll_{sh} such that $OPG(sh, \ll_{sh})$ is acyclic follows from Result 9.

Lemma 11 Consider a history H in $gen(KSFTM)$ with two transactions T_i and T_j such that both their G_valid flags are true. there is an edge from $T_i \rightarrow T_j$ then $G_tll_i < G_tll_j$.

Proof. There are three types of possible edges in MVSG.

1. Real-time edge: Since, transaction T_i and T_j are in real time order so $comTime_i < G_cts_j$. As we know from Lemma 36 ($G_tll_i \leq comTime_i$). So, ($G_tll_i \leq CTS_j$). We know from STM $stm_begin(its)$ method, $G_tll_j = G_cts_j$. Eventually, $G_tll_i < G_tll_j$.
2. Read-from edge: Since, transaction T_i has been committed and T_j is reading from T_i so, from Line 99 $stm_tryC(T_i)$, $G_tll_i = vrt_i$. and from Line 20 STM $read(j, x)$, $G_tll_j = max(G_tll_j, x[curVer].vrt + 1) \Rightarrow (G_tll_j > vrt_i) \Rightarrow (G_tll_j > G_tll_i)$ Hence, $G_tll_i < G_tll_j$.

3. Version-order edge: Consider a triplet $w_j(x_j)r_k(x_j)w_i(x_i)$ in which there are two possibilities of version order:

(a) $i \ll j \implies G_wts_i < G_wts_j$

There are two possibilities of commit order:

i. $comTime_i <_H comTime_j$: Since, T_i has been committed before T_j so $G_tltl_i = vrt_i$. From Line 53 of $stm_tryC(T_j)$, $vrt_i < G_tltl_j$.

Hence, $G_tltl_i < G_tltl_j$.

ii. $comTime_j <_H comTime_i$: Since, T_j has been committed before T_i so $G_tltl_j = vrt_j$. From Line 58 of $stm_tryC(T_i)$, $G_tutl_i < vrt_j$. As we have assumed G_valid_i is true so definitely it will execute the Line 84 $stm_tryC(T_i)$ i.e. $G_tltl_i = G_tutl_i$.

Hence, $G_tltl_i < G_tltl_j$.

(b) $j \ll i \implies G_wts_j < G_wts_i$

Again, there are two possibilities of commit order:

i. $comTime_j <_H comTime_i$: Since, T_j has been committed before T_i and T_k read from T_j . There can be two possibilities G_wts_k .

A. $G_wts_k > G_wts_i$: That means T_k is in largeRL of T_i . From Line 45 to Line 47 of $stm_tryC(i)$, either transaction T_k or T_i , G_valid flag is set to be false. If T_i returns abort then this case will not be considered in Lemma 11. Otherwise, as T_j has already been committed and later T_i will execute the Line 99 $stm_tryC(T_i)$, Hence, $G_tltl_j < G_tltl_i$.

B. $G_wts_k < G_wts_i$: That means T_k is in smallRL of T_i . From Line 17 of $read(k, x)$, $G_tutl_k < vrt_i$ and from Line 20 of $read(k, x)$, $G_tltl_k > vrt_j$. Here, T_j has already been committed so, $G_tltl_j = vrt_j$. As we have assumed G_valid_i is true so definitely it will execute the Line 99 $stm_tryC(T_i)$, $G_tltl_i = vrt_i$.

So, $G_tutl_k < G_tltl_i$ and $G_tltl_k > G_tltl_j$. While considering G_valid_k flag is true $\rightarrow G_tltl_k < G_tutl_k$.

Hence, $G_tltl_j < G_tltl_k < G_tutl_k < G_tltl_i$.

Therefore, $G_tltl_j < G_tltl_k < G_tltl_i$.

ii. $comTime_i <_H comTime_j$: Since, T_i has been committed before T_j so, $G_tltl_i = vrt_i$. From Line 58 of $stm_tryC(T_j)$, $G_tutl_j < vrt_i$ i.e. $G_tutl_j < G_tltl_i$. Here, T_k read from T_j . So, From Line 17 of $read(k, x)$, $G_tutl_k < vrt_i \rightarrow G_tutl_k < G_tltl_i$ from Line 20 of $read(k, x)$, $G_tltl_k > vrt_j$. As we have assumed G_valid_j is true so definitely it will execute the Line 99 $stm_tryC(T_j)$, $G_tltl_j = vrt_j$.

Hence, $G_tltl_j < G_tltl_k < G_tutl_k < G_tltl_i$.

Therefore, $G_tltl_j < G_tltl_k < G_tltl_i$.

Theorem 12 Any history H $gen(KSFTM)$ is local opaque iff for a given version order $\ll H$, $MVSG(H, \ll)$ is acyclic.

Proof. We are proving it by contradiction, so Assuming $MVSG(H, \ll)$ has cycle. From Lemma 11, For any two transactions T_i and T_j such that both their G_valid flags are true and if there is an edge from $T_i \rightarrow T_j$ then $G_tltl_i < G_tltl_j$. While considering transitive case for k transactions $T_1, T_2, T_3 \dots T_k$ such that G_valid flags of all the transactions are true. if there is an edge from $T_1 \rightarrow T_2 \rightarrow T_3 \rightarrow \dots \rightarrow T_k$ then $G_tltl_1 < G_tltl_2 < G_tltl_3 < \dots < G_tltl_k$.

Now, considering our assumption, $MVSG(H, \ll)$ has cycle so, $T_1 \rightarrow T_2 \rightarrow T_3 \rightarrow \dots \rightarrow T_k \rightarrow T_1$ that implies $G_tltl_1 < G_tltl_2 < G_tltl_3 < \dots < G_tltl_k < G_tltl_1$.

Hence from above assumption, $G_tltl_1 < G_tltl_1$ but this is impossible. So, our assumption is wrong.

Therefore, $MVSG(H, \ll)$ produced by $KSFTM$ is acyclic.

M_Order_H : It stands for method order of history H in which methods of transactions are interval (consists of invocation and response of a method) instead of dot (atomic). Because of having method as an interval, methods of different transactions can overlap. To prove the correctness (*local opacity*) of our algorithm, we need to order the overlapping methods.

Let say, there are two transactions T_i and T_j either accessing common (t-objects/ G_lock) or G_tCntr through operations op_i and op_j respectively. If $res(op_i) <_H inv(op_j)$ then op_i and op_j are in real-time order in H . So, the M_Order_H is $op_i \rightarrow op_j$.

If operations are overlapping and either accessing common t-objects or sharing G_lock :

1. $read_i(x)$ and $read_j(x)$: If $read_i(x)$ acquires the lock on x before $read_j(x)$ then the M_Order_H is $op_i \rightarrow op_j$.
2. $read_i(x)$ and $stm-tryC_j()$: If they are accessing common t-objects then, let say $read_i(x)$ acquires the lock on x before $stm-tryC_j()$ then the M_Order_H is $op_i \rightarrow op_j$. Now if they are not accessing common t-objects but sharing G_lock then, let say $read_i(x)$ acquires the lock on G_lock_i before $stm-tryC_j()$ acquires the lock on $relLL$ (which consists of G_lock_i and G_lock_j) then the M_Order_H is $op_i \rightarrow op_j$.
3. $stm-tryC_i()$ and $stm-tryC_j()$: If they are accessing common t-objects then, let say $stm-tryC_i()$ acquires the lock on x before $stm-tryC_j()$ then the M_Order_H is $op_i \rightarrow op_j$. Now if they are not accessing common t-objects but sharing G_lock then, let say $stm-tryC_i()$ acquires the lock on $relLL_i$ before $stm-tryC_j()$ then the M_Order_H is $op_i \rightarrow op_j$.

If operations are overlapping and accessing different t-objects but sharing G_tCntr counter:

1. $stm-begin_i$ and $stm-begin_j$: Both the $stm-begin$ are accessing shared counter variable G_tCntr . If $stm-begin_i$ executes $G_tCntr.get\&Inc()$ before $stm-begin_j$ then the M_Order_H is $op_i \rightarrow op_j$.
2. $stm-begin_i$ and $stm-tryC(j)$: If $stm-begin_i$ executes $G_tCntr.get\&Inc()$ before $stm-tryC(j)$ then the M_Order_H is $op_i \rightarrow op_j$.

Linearization: The history generated by STMs are generally not sequential because operations of the transactions are overlapping. The correctness of STMs is defined on sequential history, in order to show history generated by our algorithm is correct we have to consider sequential history. We have enough information to order the overlapping methods, after ordering the operations will have equivalent sequential history, the total order of the operation is called linearization of the history.

Operation graph (OPG): Consider each operation as a vertex and edges as below:

1. Real time edge: If response of operation op_i happen before the invocation of operation op_j i.e. $rsp(op_i) <_H inv(op_j)$ then there exist real time edge between $op_i \rightarrow op_j$.
2. Conflict edge: It is based on L_Order_H which depends on three conflicts:
 - (a) Common *t-object*: If two operations op_i and op_j are overlapping and accessing common *t-object* x . Let say op_i acquire lock first on x then $L_Order.op_i(x) <_H L_Order.op_j(x)$ so, conflict edge is $op_i \rightarrow op_j$.
 - (b) Common G_valid flag: If two operation op_i and op_j are overlapping but accessing common G_valid flag instead of *t-object*. Let say op_i acquire lock first on G_valid_i then $L_Order.op_i(x) <_H L_Order.op_j(x)$ so, conflict edge is $op_i \rightarrow op_j$.
3. Common G_tCntr counter: If two operation op_i and op_j are overlapping but accessing common G_tCntr counter instead of *t-object*. Let say op_i access G_tCntr counter before op_j then $L_Order.op_i(x) <_H L_Order.op_j(x)$ so, conflict edge is $op_i \rightarrow op_j$.

Lemma 13 All the locks in history H (L_Order_H) $gen(KSFTM)$ follows strict partial order. So, operation graph ($OPG(H)$) is acyclic. If $(op_i \rightarrow op_j)$ in OPG , then atleast one of them will definitely true: $(Fpu_i(\alpha) < Lpl_op_j(\alpha)) \cup (access.G_tCntr_i < access.G_tCntr_j) \cup (Fpu_op_i(\alpha) < access.G_tCntr_j) \cup (access.G_tCntr_i < Lpl_op_j(\alpha))$. Here, α can either be *t-object* or G_valid .

Proof. we consider proof by induction, So we assumed there exist a path from op_1 to op_n and there is an edge between op_n to op_{n+1} . As we described, while constructing $OPG(H)$ we need to consider three types of edges. We are considering one by one:

1. Real time edge between op_n to op_{n+1} :
 - (a) op_{n+1} is a locking method: In this we are considering all the possible path between op_1 to op_n :

- i. ($Fu_{op_1}(\alpha) < Ll_{op_n}(\alpha)$): **Here**, ($Fu_{op_n}(\alpha) < Ll_{op_{n+1}}(\alpha)$).
So, ($Fu_{op_1}(\alpha) < Ll_{op_n}(\alpha) < (Fu_{op_n}(\alpha) < Ll_{op_{n+1}}(\alpha)$)
Hence, ($Fu_{op_1}(\alpha) < Ll_{op_{n+1}}(\alpha)$)
 - ii. ($Fu_{op_1}(\alpha) < Ll_{op_n}(\alpha)$): **Here**, ($access.G.tCntr_n < Ll_{op_{n+1}}(\alpha)$). As we know if any method is locking as well as accessing common counter then locking tobject first then access-
ing the counter after that unlocking tobject i.e.
So, ($Ll_{op_n}(\alpha) < (access.G.tCntr_n) < (Fu_{op_n}(\alpha))$).
Hence, ($Fu_{op_1}(\alpha) < Ll_{op_{n+1}}(\alpha)$)
 - iii. ($access.G.tCntr_1 < (access.G.tCntr_n)$): **Here**, ($access.G.tCntr_n < Ll_{op_{n+1}}(\alpha)$).
So, ($access.G.tCntr_1 < (access.G.tCntr_n) < Ll_{op_{n+1}}(\alpha)$).
Hence, ($access.G.tCntr_1 < Ll_{op_{n+1}}(\alpha)$).
 - iv. ($Fu_{op_1}(\alpha) < (access.G.tCntr_n)$): **Here**, ($access.G.tCntr_n < Ll_{op_{n+1}}(\alpha)$).
So, ($Fu_{op_1}(\alpha) < (access.G.tCntr_n) < Ll_{op_{n+1}}(\alpha)$).
Hence, ($Fu_{op_1}(\alpha) < Ll_{op_{n+1}}(\alpha)$)
 - v. ($access.G.tCntr_1 < Ll_{op_n}(\alpha)$): **Here**, ($Fu_{op_n}(\alpha) < Ll_{op_{n+1}}(\alpha)$).
So, ($access.G.tCntr_1 < Ll_{op_n}(\alpha) < (Fu_{op_n}(\alpha) < Ll_{op_{n+1}}(\alpha))$).
Hence, ($access.G.tCntr_1 < Ll_{op_{n+1}}(\alpha)$).
 - vi. ($access.G.tCntr_1 < Ll_{op_n}(\alpha)$): **Here**, ($access.G.tCntr_n < Ll_{op_{n+1}}(\alpha)$). As we know if any
method is locking as well as accessing common counter then locking tobject first then accessing
the counter after that unlocking tobject i.e.
So, ($Ll_{op_n}(\alpha) < (access.G.tCntr_n) < (Fu_{op_n}(\alpha))$).
Hence, ($access.G.tCntr_1 < Ll_{op_{n+1}}(\alpha)$).
- (b) op_{n+1} is a non-locking method: Again, we are considering all the possible path between op_1 to op_n :
- i. ($Fu_{op_1}(\alpha) < Ll_{op_n}(\alpha)$): **Here**, ($access.G.tCntr_n < (access.G.tCntr_{n+1})$).
As we know if any method is locking as well as accessing common counter then locking tobject
first then accessing the counter after that unlocking tobject i.e.
So, ($Ll_{op_n}(\alpha) < (access.G.tCntr_n) < (Fu_{op_n}(\alpha))$).
Hence, ($Fu_{op_1}(\alpha) < (access.G.tCntr_{n+1})$)
 - ii. ($Fu_{op_1}(\alpha) < Ll_{op_n}(\alpha)$): **Here**, ($Fu_{op_n}(\alpha) < (access.G.tCntr_{n+1})$).
So, ($Fu_{op_1}(\alpha) < Ll_{op_n}(\alpha) < (Fu_{op_n}(\alpha) < (access.G.tCntr_{n+1})$)
Hence, ($Fu_{op_1}(\alpha) < (access.G.tCntr_{n+1})$)
 - iii. ($access.G.tCntr_1 < (access.G.tCntr_n)$): **Here**, ($access.G.tCntr_n < (access.G.tCntr_{n+1})$).
So, ($access.G.tCntr_1 < (access.G.tCntr_n) < (access.G.tCntr_{n+1})$).
Hence, ($access.G.tCntr_1 < (access.G.tCntr_{n+1})$).
 - iv. ($Fu_{op_1}(\alpha) < (access.G.tCntr_n)$): **Here**, ($access.G.tCntr_n < (access.G.tCntr_{n+1})$).
So, ($Fu_{op_1}(\alpha) < (access.G.tCntr_n) < (access.G.tCntr_{n+1})$).
Hence, ($Fu_{op_1}(\alpha) < (access.G.tCntr_{n+1})$)
 - v. ($access.G.tCntr_1 < Ll_{op_n}(\alpha)$): **Here**, ($access.G.tCntr_n < (access.G.tCntr_{n+1})$).
As we know if any method is locking as well as accessing common counter then locking tobject
first then accessing the counter after that unlocking tobject i.e.
So, ($Ll_{op_n}(\alpha) < (access.G.tCntr_n) < (Fu_{op_n}(\alpha))$).
Hence, ($access.G.tCntr_1 < (access.G.tCntr_{n+1})$).
 - vi. ($access.G.tCntr_1 < Ll_{op_n}(\alpha)$): **Here**, ($Fu_{op_n}(\alpha) < (access.G.tCntr_{n+1})$).
So, ($access.G.tCntr_1 < Ll_{op_n}(\alpha) < (Fu_{op_n}(\alpha) < (access.G.tCntr_{n+1})$).
Hence, ($access.G.tCntr_1 < (access.G.tCntr_{n+1})$).

2. Conflict edge between op_n to op_{n+1} :

- (a) ($Fu_{op_1}(\alpha) < Ll_{op_n}(\alpha)$): **Here**, ($Fu_{op_n}(\alpha) < Ll_{op_{n+1}}(\alpha)$). Ref 1.(a).i.
- (b) ($access.G.tCntr_1 < (access.G.tCntr_n)$): **Here**, ($Fu_{op_n}(\alpha) < Ll_{op_{n+1}}(\alpha)$). As we know if any
method is locking as well as accessing common counter then locking tobject first then accessing the
counter after that unlocking tobject i.e.
So, ($Ll_{op_n}(\alpha) < (access.G.tCntr_n) < (Fu_{op_n}(\alpha))$).
Hence, ($access.G.tCntr_1 < Ll_{op_{n+1}}(\alpha)$).

- (c) $(Fu_op_1(\alpha) < (access.G_tCntr_n))$: Here, $(Fu_op_n(\alpha) < Ll_op_{n+1}(\alpha))$. As we know if any method is locking as well as accessing common counter then locking tobject first then accessing the counter after that unlocking tobject i.e.
 So, $(Ll_op_n(\alpha) < (access.G_tCntr_n) < (Fu_op_n(\alpha))$.
 Hence, $(Fu_op_1(\alpha) < Ll_op_{n+1}(\alpha))$.
- (d) $(access.G_tCntr_1) < Ll_op_n(\alpha)$: Here, $(Fu_op_n(\alpha) < Ll_op_{n+1}(\alpha))$.
 Ref 1.(a).v.

3. Common counter edge between op_n to op_{n+1} :

- (a) $(Fu_op_1(\alpha) < Ll_op_n(\alpha))$: Here, $(access.G_tCntr_n) < (access.G_tCntr_{n+1})$. As we know if any method is locking as well as accessing common counter then locking tobject first then accessing the counter after that unlocking tobject i.e.
 So, $(Ll_op_n(\alpha) < (access.G_tCntr_n) < (Fu_op_n(\alpha))$.
 Hence, $(Fu_op_1(\alpha) < (access.G_tCntr_{n+1}))$.
- (b) $(access.G_tCntr_1) < (access.G_tCntr_n)$: Here, $(access.G_tCntr_n) < (access.G_tCntr_{n+1})$. Ref 1.(b).iii.
- (c) $(Fu_op_1(\alpha) < (access.G_tCntr_n))$: Here, $(access.G_tCntr_n) < (access.G_tCntr_{n+1})$. Ref 1.(b).iv.
- (d) $(access.G_tCntr_1) < Ll_op_n(\alpha)$: Here, $(access.G_tCntr_n) < (access.G_tCntr_{n+1})$. Ref 1.(b).v

Therefore, $OPG(H, M_Order)$ produced by KSFTM is acyclic.

Lemma 14 Any history H gen(KSFTM) with α linearization such that it respects M_Order_H then (H, α) is valid.

Proof. From the definition of *valid history*: If all the read operations of H is reading from the previously committed transaction T_j then H is valid.

In order to prove H is valid, we are analyzing the read(i,x). so, from Line 10, it returns the largest t_s value less than G_wts_i that has already been committed and return the value successfully. If such version created by transaction T_j found then T_i read from T_j . Otherwise, if there is no version whose WTS is less than T_i 's WTS, then T_i returns abort.

Now, consider the base case read(i,x) is the first transaction T_1 and none of the transactions has been created a version then as we have assumed, there always exist T_0 by default that has been created a version for all t-objects. Hence, T_1 reads from committed transaction T_0 .

So, all the reads are reading from largest t_s value less than G_wts_i that has already been committed. Hence, (H, α) is valid.

Lemma 15 Any history H gen(KSFTM) with α and β linearization such that both respects M_Order_H i.e. $M_Order_H \subseteq \alpha$ and $M_Order_H \subseteq \beta$ then $\prec_{(H,\alpha)}^{RT} = \prec_{(H,\beta)}^{RT}$.

Proof. Consider a history H gen(KSFTM) such that two transactions T_i and T_j are in real time order which respects M_Order_H i.e. $stm_tryC_i < stm_begin_j$. As α and β are linearizations of H so, $stm_tryC_i <_{(H,\alpha)} stm_begin_j$ and $stm_tryC_i <_{(H,\beta)} stm_begin_j$. Hence in both the cases of linearizations, T_i committed before begin of T_j . So, $\prec_{(H,\alpha)}^{RT} = \prec_{(H,\beta)}^{RT}$.

Lemma 16 Any history H gen(KSFTM) with α and β linearization such that both respects M_Order_H i.e. $M_Order_H \subseteq \alpha$ and $M_Order_H \subseteq \beta$ then (H, α) is local opaque iff (H, β) is local opaque.

Proof. As α and β are linearizations of history H gen(KSFTM) so, from Lemma 14 (H, α) and (H, β) are valid histories.

Now assuming (H, α) is local opaque so we need to show (H, β) is also local opaque. Since (H, α) is local opaque so there exists legal t-sequential history S (with respect to each aborted transactions and last committed transaction while considering only committed transactions) which is equivalent to (\overline{H}, α) . As we know β is a linearization of H so (\overline{H}, β) is equivalent to some legal t-sequential history S. From the definition of local opacity $\prec_{(H,\alpha)}^{RT} \subseteq \prec_S^{RT}$. From Lemma 15, $\prec_{(H,\alpha)}^{RT} = \prec_{(H,\beta)}^{RT}$ that implies $\prec_{(H,\beta)}^{RT} \subseteq \prec_S^{RT}$. Hence, (H, β) is local opaque.

Now consider the other way in which (H, β) is local opaque and we need to show (H, α) is also local opaque. We can prove it while giving the same argument as above, by exchanging α and β .

Hence, (H, α) is local opaque iff (H, β) is local opaque.

Theorem 17 Any history generated by *KSFTM* is locally-opaque.

Proof. For proving this, we consider a sequential history H generated by *KSFTM*. We define the version order \ll_{vrt} : for two versions v_i, v_j it is defined as
 $(v_i \ll_{\text{vrt}} v_j) \equiv (v_i.\text{vrt} < v_j.\text{vrt})$

Using this version order \ll_{vrt} , we can show that all the sub-histories in $H.\text{subhistSet}$ are acyclic. Since the histories generated by *KSFTM* are locally-opaque, we get that they are also strict-serializable.

Corollary 18 Any history generated by *KSFTM* is strict-serializable.

6 Proof of Liveness

Proof Notations: Let $\text{gen}(\text{KSFTM})$ consist of all the histories accepted by *KSFTM* algorithm. In the follow subsection, we only consider histories that are generated by *KSFTM* unless explicitly stated otherwise. For simplicity, we only consider sequential histories in our discussion below.

Consider a transaction T_i in a history H generated by *KSFTM*. Once it executes *stm-begin* method, its ITS, CTS, WTS values do not change. Thus, we denote them as its_i, cts_i, wts_i respectively for T_i . In case the context of the history H in which the transaction executing is important, we denote these variables as $H.its_i, H.cts_i, H.wts_i$ respectively.

The other variables that a transaction maintains are: *tltl*, *tutl*, *lock*, *valid*, *state*. These values change as the execution proceeds. Hence, we denote them as: $H.tltl_i, H.tutl_i, H.lock_i, H.valid_i, H.state_i$. These represent the values of *tltl*, *tutl*, *lock*, *valid*, *state* after the execution of last event in H . Depending on the context, we sometimes ignore H and denote them only as: $lock_i, valid_i, state_i, tltl_i, tutl_i$.

We approximate the system time with the value of $tCntr$. We denote the sys-time of history H as the value of $tCntr$ immediately after the last event of H . Further, we also assume that the value of C is 1 in our arguments. But, it can be seen that the proof will work for any value greater than 1 as well.

The application invokes transactions in such a way that if the current T_i transaction aborts, it invokes a new transaction T_j with the same ITS. We say that T_i is an *incarnation* of T_j in a history H if $H.its_i = H.its_j$. Thus the multiple incarnations of a transaction T_i get invoked by the application until an incarnation finally commits.

To capture this notion of multiple transactions with the same ITS, we define *incarSet* (incarnation set) of T_i in H as the set of all the transactions in H which have the same ITS as T_i and includes T_i as well. Formally,

$$H.incarSet(T_i) = \{T_j | (T_i = T_j) \vee (H.its_i = H.its_j)\}$$

Note that from this definition of *incarSet*, we implicitly get that T_i and all the transactions in its *incarSet* of H also belong to H . Formally, $H.incarSet(T_i) \in H.txns$.

The application invokes different incarnations of a transaction T_i in such a way that as long as an incarnation is live, it does not invoke the next incarnation. It invokes the next incarnation after the current incarnation has got aborted. Once an incarnation of T_i has committed, it can't have any future incarnations. Thus, the application views all the incarnations of a transaction as a single *application-transaction*.

We assign *incNums* to all the transactions that have the same ITS. We say that a transaction T_i starts *afresh*, if $T_i.incNum$ is 1. We say that T_i is the *nextInc* of T_j if T_j and T_i have the same ITS and T_i 's *incNum* is T_j 's *incNum* + 1. Formally, $\langle (T_i.nextInc = T_j) \equiv (its_i = its_j) \wedge (T_i.incNum = T_j.incNum + 1) \rangle$

As mentioned the objective of the application is to ensure that every application-transaction eventually commits. Thus, the applications views the entire *incarSet* as a single application-transaction (with all the transactions in the *incarSet* having the same ITS). We can say that an application-transaction has committed if in the corresponding *incarSet* a transaction in eventually commits. For T_i in a history H , we denote this by a boolean value *incarCt* (incarnation set committed) which implies that either T_i or an incarnation of T_i has committed. Formally, we define it as $H.incarCt(T_i)$

$$H.incarCt(T_i) = \begin{cases} True & (\exists T_j : (T_j \in H.incarSet(T_i)) \wedge (T_j \in H.committed)) \\ False & \text{otherwise} \end{cases}$$

From the definition of *incarCt* we get the following observations & lemmas about a transaction T_i

Observation 19 Consider a transaction T_i in a history H with its *incarCt* being true in H . Then T_i is terminated (either committed or aborted) in H . Formally, $\langle H, T_i : (T_i \in H.txns) \wedge (H.incarCt(T_i)) \implies (T_i \in H.terminated) \rangle$.

Observation 20 Consider a transaction T_i in a history H with its $incarCt$ being true in $H1$. Let $H2$ be a extension of $H1$ with a transaction T_j in it. Suppose T_j is an incarnation of T_i . Then T_j 's $incarCt$ is true in $H2$. Formally, $\langle H1, H2, T_i, T_j : (H1 \sqsubseteq H2) \wedge (H1.incarCt(T_i)) \wedge (T_j \in H2.txns) \wedge (T_i \in H2.incarSet(T_j)) \implies (H2.incarCt(T_j)) \rangle$.

Lemma 21 Consider a history $H1$ with a strict extension $H2$. Let T_i & T_j be two transactions in $H1$ & $H2$ respectively. Let T_j not be in $H1$. Suppose T_i 's $incarCt$ is true. Then ITS of T_i cannot be the same as ITS of T_j . Formally, $\langle H1, H2, T_i, T_j : (H1 \sqsubset H2) \wedge (H1.incarCt(T_i)) \wedge (T_j \in H2.txns) \wedge (T_j \notin H1.txns) \implies (H1.its_i \neq H2.its_j) \rangle$.

Proof. Here, we have that T_i 's $incarCt$ is true in $H1$. Suppose T_j is an incarnation of T_i , i.e., their ITSs are the same. We are given that T_j is not in $H1$. This implies that T_j must have started after the last event of $H1$.

We are also given that T_i 's $incarCt$ is true in $H1$. This implies that an incarnation of T_i or T_i itself has committed in $H1$. After this commit, the application will not invoke another transaction with the same ITS as T_i . Thus, there cannot be a transaction after the last event of $H1$ and in any extension of $H1$ with the same ITS of T_i . Hence, $H1.its_i$ cannot be same as $H2.its_j$.

Now we show the liveness with the following observations, lemmas & theorems. We start with two observations about that histories of which one is an extension of the other. The following states that for any history, there exists an extension. In other words, we assume that the STM system runs forever and does not terminate. This is required for showing that every transaction eventually commits.

Observation 22 Consider a history $H1$ generated by $gen(KSFTM)$. Then there is a history $H2$ in $gen(KSFTM)$ such that $H2$ is a strict extension of $H1$. Formally, $\langle \forall H1 : (H1 \in gen(ksftm)) \implies (\exists H2 : (H2 \in gen(ksftm)) \wedge (H1 \sqsubset H2)) \rangle$.

The follow observation is about the transaction in a history and any of its extensions.

Observation 23 Given two histories $H1$ & $H2$ such that $H2$ is an extension of $H1$. Then, the set of transactions in $H1$ are a subset equal to the set of transaction in $H2$. Formally, $\langle \forall H1, H2 : (H1 \sqsubseteq H2) \implies (H1.txns \subseteq H2.txns) \rangle$.

In order for a transaction T_i to commit in a history H , it has to compete with all the live transactions and all the aborted that can become live again as a different incarnation. Once a transaction T_j aborts, another incarnation of T_j can start and become live again. Thus T_i will have to compete with this incarnation of T_j later. Thus, we have the following observation about aborted & committed transactions.

Observation 24 Consider an aborted transaction T_i in a history $H1$. Then there is an extension of $H1$, $H2$ in which an incarnation of T_i, T_j is live and has cts_j is greater than cts_i . Formally, $\langle H1, T_i : (T_i \in H1.aborted) \implies (\exists T_j, H2 : (H1 \sqsubseteq H2) \wedge (T_j \in H2.live) \wedge (H2.its_i = H2.its_j) \wedge (H2.cts_i < H2.cts_j)) \rangle$.

Observation 25 Consider an committed transaction T_i in a history $H1$. Then there is no extension of $H1$, in which an incarnation of T_i, T_j is live. Formally, $\langle H1, T_i : (T_i \in H1.committed) \implies (\nexists T_j, H2 : (H1 \sqsubseteq H2) \wedge (T_j \in H2.live) \wedge (H2.its_i = H2.its_j)) \rangle$.

Lemma 26 Consider a history $H1$ and its extension $H2$. Let T_i, T_j be in $H1, H2$ respectively such that they are incarnations of each other. If WTS of T_i is less than WTS of T_j then CTS of T_i is less than CTS T_j . Formally, $\langle H1, H2, T_i, T_j : (H1 \sqsubset H2) \wedge (T_i \in H1.txns) \wedge (T_j \in H2.txns) \wedge (T_i \in H2.incarSet(T_j)) \wedge (H1.wts_i < H2.wts_j) \implies (H1.cts_i < H2.cts_j) \rangle$

Proof. Here we are given that

$$H1.wts_i < H2.wts_j \tag{2}$$

The definition of WTS of T_i is: $H1.wts_i = H1.cts_i + C * (H1.cts_i - H1.its_i)$. Combining this Eq.(2), we get that

$$(C+1)*H1.cts_i - C*H1.its_i < (C+1)*H2.cts_j - C*H2.its_j \xrightarrow[H1.its_i=H2.its_j]{T_i \in H2.incarSet(T_j)} H1.cts_i < H2.cts_j.$$

Lemma 27 Consider a live transaction T_i in a history $H1$ with its wts_i less than a constant α . Then there is a strict extension of $H1$, $H2$ in which an incarnation of T_i, T_j is live with WTS greater than α . Formally, $\langle H1, T_i : (T_i \in H1.live) \wedge (H1.wts_i < \alpha) \implies (\exists T_j, H2 : (H1 \sqsubseteq H2) \wedge (T_i \in H2.incarSet(T_j)) \wedge ((T_j \in H2.committed) \vee ((T_j \in H2.live) \wedge (H2.wts_j > \alpha)))) \rangle$.

Proof. The proof comes the behavior of an application-transaction. The application keeps invoking a transaction with the same ITS until it commits. Thus the transaction T_i which is live in $H1$ will eventually terminate with an abort or commit. If it commits, $H2$ could be any history after the commit of T_2 .

On the other hand if T_i is aborted, as seen in Observation 24 it will be invoked again or reincarnated with another CTS and WTS. It can be seen that CTS is always increasing. As a result, the WTS is also increasing. Thus eventually the WTS will become greater α . Hence, we have that either an incarnation of T_i will get committed or will eventually have WTS greater than or equal to α .

Next we have a lemma about CTS of a transaction and the sys-time of a history.

Lemma 28 Consider a transaction T_i in a history H . Then, we have that CTS of T_i will be less than or equal to sys-time of H . Formally, $\langle T_i, H1 : (T_i \in H.txns) \implies (H.cts_i \leq H.sys-time) \rangle$.

Proof. We get this lemma by observing the methods of the STM System that increment the tCntr which are stm-begin and stm-tryC. It can be seen that CTS of T_i gets assigned in the stm-begin method. So if the last method of H is the stm-begin of T_i then we get that CTS of T_i is same as sys-time of H . On the other hand if some other method got executed in H after stm-begin of T_i then we have that CTS of T_i is less than sys-time of H . Thus combining both the cases, we get that CTS of T_i is less than or equal to as sys-time of H , i.e., $(H.cts_i \leq H.sys-time)$

From this lemma, we get the following corollary which is the converse of the lemma statement

Corollary 29 Consider a transaction T_i which is not in a history $H1$ but in an strict extension of $H1$, $H2$. Then, we have that CTS of T_i is greater than the sys-time of H . Formally, $\langle T_i, H1, H2 : (H1 \sqsubset H2) \wedge (T_i \notin H1.txns) \wedge (T_i \in H2.txns) \implies (H2.cts_i > H1.sys-time) \rangle$.

Now, we have lemma about the methods of *KSFTM* completing in finite time.

Lemma 30 If all the locks are fair and the underlying system scheduler is fair then all the methods of *KSFTM* will eventually complete.

Proof. It can be seen that in any method, whenever a transaction T_i obtains multiple locks, it obtains locks in the same order: first lock relevant t-objects in a pre-defined order and then lock relevant G_locks again in a predefined order. Since all the locks are obtained in the same order, it can be seen that the methods of *KSFTM* will not deadlock.

It can also be seen that none of the methods have any unbounded while loops. All the loops in stm-tryC method iterate through all the t-objects in the write-set of T_i . Moreover, since we assume that the underlying scheduler is fair, we can see that no thread gets swapped out infinitely. Finally, since we assume that all the locks are fair, it can be seen all the methods terminate in finite time.

Theorem 31 Every transaction either commits or aborts in finite time.

Proof. This theorem comes directly from the Lemma 30. Since every method of *KSFTM* will eventually complete, all the transactions will either commit or abort in finite time.

From this theorem, we get the following corollary which states that the maximum *lifetime* of any transaction is L .

Corollary 32 Any transaction T_i in a history H will either commit or abort before the sys-time of H crosses $cts_i + L$.

The following lemma connects WTS and ITS of two transactions, T_i, T_j .

Lemma 33 Consider a history $H1$ with two transactions T_i, T_j . Let T_i be in $H1.live$. Suppose T_j 's WTS is greater or equal to T_i 's WTS. Then ITS of T_j is less than $its_i + 2 * L$. Formally, $\langle H, T_i, T_j : (\{T_i, T_j\} \subseteq H.txns) \wedge (T_i \in H.live) \wedge (H.wts_j \geq H.wts_i) \implies (H.its_i + 2L \geq H.its_j) \rangle$.

Proof. Since T_i is live in $H1$, from Corollary 32, we get that it terminates before the system time, $tCntr$ becomes $cts_i + L$. Thus, sys-time of history $H1$ did not progress beyond $cts_i + L$. Hence, for any other transaction T_j (which is either live or terminated) in $H1$, it must have started before sys-time has crossed $cts_i + L$. Formally $\langle cts_j \leq cts_i + L \rangle$.

Note that we have defined WTS of a transaction T_j as: $wts_j = (cts_j + C * (cts_j - its_j))$. Now, let us consider the difference of the WTSs of both the transactions.

$$\begin{aligned}
wts_j - wts_i &= (cts_j + C * (cts_j - its_j)) - (cts_i + C * (cts_i - its_i)) \\
&= (C + 1)(cts_j - cts_i) - C(its_j - its_i) \\
&\leq (C + 1)L - C(its_j - its_i) \quad [:\cdot cts_j \leq cts_i + L] \\
&= 2 * L + its_i - its_j \quad [:\cdot C = 1]
\end{aligned}$$

Thus, we have that: $\langle (its_i + 2L - its_j) \geq (wts_j - wts_i) \rangle$. This gives us that $\langle (wts_j - wts_i) \geq 0 \rangle \implies \langle (its_i + 2L - its_j) \geq 0 \rangle$.

From the above implication we get that, $\langle wts_j \geq wts_i \rangle \implies \langle its_i + 2L \geq its_j \rangle$.

It can be seen that *KSFTM* algorithm gives preference to transactions with lower ITS to commit. To understand this notion of preference, we define a few notions of enablement of a transaction T_i in a history H . We start with the definition of *itsEnabled* as:

Definition 2 We say T_i is *itsEnabled* in H if for all transactions T_j with ITS lower than ITS of T_i in H have *incarCt* to be true. Formally,

$$H.\text{itsEnabled}(T_i) = \begin{cases} \text{True} & (T_i \in H.\text{live}) \wedge (\forall T_j \in H.\text{txns} : (H.\text{its}_j < H.\text{its}_i) \implies (H.\text{incarCt}(T_j))) \\ \text{False} & \text{otherwise} \end{cases}$$

The follow lemma states that once a transaction T_i becomes *itsEnabled* it continues to remain so until it terminates.

Lemma 34 Consider two histories $H1$ and $H2$ with $H2$ being a extension of $H1$. Let a transaction T_i being live in both of them. Suppose T_i is *itsEnabled* in $H1$. Then T_i is *itsEnabled* in $H2$ as well. Formally, $\langle H1, H2, T_i : (H1 \sqsubseteq H2) \wedge (T_i \in H1.\text{live}) \wedge (T_i \in H2.\text{live}) \wedge (H1.\text{itsEnabled}(T_i)) \implies (H2.\text{itsEnabled}(T_i)) \rangle$.

Proof. When T_i begins in a history $H3$ let the set of transactions with ITS less than its_i be *smIts*. Then in any extension of $H3$, $H4$ the set of transactions with ITS less than its_i remains as *smIts*.

Suppose $H1, H2$ are extensions of $H3$. Thus in $H1, H2$ the set of transactions with ITS less than its_i will be *smIts*. Hence, if T_i is *itsEnabled* in $H1$ then all the transactions T_j in *smIts* are $H1.\text{incarCt}(T_j)$. It can be seen that this continues to remain true in $H2$. Hence in $H2$, T_i is also *itsEnabled* which proves the lemma.

The following lemma deals with a committed transaction T_i and any transaction T_j that terminates later. In the following lemma, *incrVal* is any constant greater than or equal to 1.

Lemma 35 Consider a history H with two transactions T_i, T_j in it. Suppose transaction T_i commits before T_j terminates (either by commit or abort) in H . Then *comTime_i* is less than *comTime_j* by at least *incrVal*. Formally, $\langle H, \{T_i, T_j\} \in H.\text{txns} : (\text{stm-tryC}_i <_H \text{term-op}_j) \implies (\text{comTime}_i + \text{incrVal} \leq \text{comTime}_j) \rangle$.

Proof. When T_i commits, let the value of the global *tCntr* be α . It can be seen that in *stm-begin* method, *comTime_j* get initialized to ∞ . The only place where *comTime_j* gets modified is at Line 61 of *stm-tryC*. Thus if T_j gets aborted before executing *stm-tryC* method or before this line of *stm-tryC* we have that *comTime_j* remains at ∞ . Hence in this case we have that $\langle \text{comTime}_i + \text{incrVal} < \text{comTime}_j \rangle$.

If T_j terminates after executing Line 61 of *stm-tryC* method then *comTime_j* is assigned a value, say β . It can be seen that β will be greater than α by at least *incrVal* due to the execution of this line. Thus, we have that $\langle \alpha + \text{incrVal} \leq \beta \rangle$

The following lemma connects the *G.ttl* and *comTime* of a transaction T_i .

Lemma 36 Consider a history H with a transaction T_i in it. Then in H , *tll_i* will be less than or equal to *comTime_i*. Formally, $\langle H, \{T_i\} \in H.\text{txns} : (H.\text{tll}_i \leq H.\text{comTime}_i) \rangle$.

Proof. Consider the transaction T_i . In *stm-begin* method, *comTime_i* get initialized to ∞ . The only place where *comTime_i* gets modified is at Line 61 of *stm-tryC*. Thus if T_i gets aborted before this line or if T_i is live we have that $\langle \text{tll}_i \leq \text{comTime}_i \rangle$. On executing Line 61, *comTime_i* gets assigned to some finite value and it does not change after that.

It can be seen that *tll_i* gets initialized to cts_i in Line 4 of *stm-begin* method. In that line, cts_i reads *tCntr* and increments it atomically. Then in Line 61, *comTime_i* gets assigned the value of *tCntr* after incrementing it. Thus, we clearly get that $cts_i (= \text{tll}_i \text{ initially}) < \text{comTime}_i$. Then *tll_i* gets updated on Line 20 of *read*, Line 53 and Line 84 of *stm-tryC* methods. Let us analyze them case by case assuming that *tll_i* was last updated in each of these methods before the termination of T_i :

1. Line 20 of read method: Suppose this is the last line where tll_i updated. Here tll_i gets assigned to $1 + \text{vrt}$ of the previously committed version which say was created by a transaction T_j . Thus, we have the following equation,

$$tll_i = 1 + x[j].\text{vrt} \quad (3)$$

It can be seen that $x[j].\text{vrt}$ is same as tll_j when T_j executed Line 99 of `stm-tryC`. Further, tll_j in turn is same as $tutl_j$ due to Line 84 of `stm-tryC`. From Line 62, it can be seen that $tutl_j$ is less than or equal to comTime_j when T_j committed. Thus we have that

$$x[j].\text{vrt} = tll_j = tutl_j \leq \text{comTime}_j \quad (4)$$

It is clear that from the above discussion that T_j executed `stm-tryC` method before T_i terminated (i.e. $\text{stm-tryC}_j <_{H1} \text{term-op}_i$). From Eq.(3) and Eq.(4), we get

$$tll_i \leq 1 + \text{comTime}_j \xrightarrow{\text{incrVal} \geq 1} tll_i \leq \text{incrVal} + \text{comTime}_j \xrightarrow{\text{Lemma 35}} tll_i \leq \text{comTime}_i$$

2. Line 53 of `stm-tryC` method: The reasoning in this case is very similar to the above case.
3. Line 84 of `stm-tryC` method: In this line, tll_i is made equal to $tutl_i$. Further, in Line 62, $tutl_i$ is made lesser than or equal to comTime_i . Thus combing these, we get that $tll_i \leq \text{comTime}_i$. It can be seen that the reasoning here is similar in part to Case 1.

Hence, in all the three cases we get that $\langle tll_i \leq \text{comTime}_i \rangle$.

The following lemma connects the $G.\text{tutl}, \text{comTime}$ of a transaction T_i with WTS of a transaction T_j that has already committed.

Lemma 37 Consider a history H with a transaction T_i in it. Suppose $tutl_i$ is less than comTime_i . Then, there is a committed transaction T_j in H such that wts_j is greater than wts_i . Formally, $\langle H \in \text{gen}(\text{KSFTM}), \{T_i\} \in H.\text{txns} : (H.\text{tutl}_i < H.\text{comTime}_i) \implies (\exists T_j \in H.\text{committed} : H.\text{wts}_j > H.\text{wts}_i) \rangle$.

Proof. It can be seen that $G.\text{tutl}_i$ initialized in `stm-begin` method to ∞ . $tutl_i$ is updated in Line 17 of read method, Line 58 & Line 62 of `stm-tryC` method. If T_i executes Line 17 of read method and/or Line 58 of `stm-tryC` method then $tutl_i$ gets decremented to some value less than ∞ , say α . Further, it can be seen that in both these lines the value of $tutl_i$ is possibly decremented from ∞ because of nextVer (or ver), a version of x whose ts is greater than T_i 's WTS. This implies that some transaction T_j , which is committed in H , must have created nextVer (or ver) and $\text{wts}_j > \text{wts}_i$.

Next, let us analyze the value of α . It can be seen that $\alpha = x[\text{nextVer}/\text{ver}].\text{vrt} - 1$ where $\text{nextVer}/\text{ver}$ was created by T_j . Further, we can see when T_j executed `stm-tryC`, we have that $x[\text{nextVer}].\text{vrt} = tll_j$ (from Line 99). From Lemma 36, we get that $tll_j \leq \text{comTime}_j$. This implies that $\alpha < \text{comTime}_j$. Now, we have that T_j has already committed before the termination of T_i . Thus from Lemma 35, we get that $\text{comTime}_j < \text{comTime}_i$. Hence, we have that,

$$\alpha < \text{comTime}_i \quad (5)$$

Now let us consider Line 62 executed by T_i which causes $tutl_i$ to change. This line will get executed only after both Line 17 of read method, Line 58 of `stm-tryC` method. This is because every transaction executes `stm-tryC` method only after read method. Further within `stm-tryC` method, Line 62 follows Line 58.

There are two sub-cases depending on the value of $tutl_i$ before the execution of Line 62: (i) If $tutl_i$ was ∞ and then get decremented to comTime_i upon executing this line, then we get $\text{comTime}_i = tutl_i$. From Eq.(5), we can ignore this case. (ii) Suppose the value of $tutl_i$ before executing Line 62 was α . Then from Eq.(5) we get that $tutl_i$ remains at α on execution of Line 62. This implies that a transaction T_j committed such that $\text{wts}_j > \text{wts}_i$. The following lemma connects the $G.\text{tutl}$ of a committed transaction T_j and comTime of a transaction T_i that commits later.

Lemma 38 Consider a history $H1$ with transactions T_i, T_j in it. Suppose T_j is committed and T_i is live in $H1$. Then in any extension of $H1$, say $H2$, tll_j is less than or equal to comTime_i . Formally, $\langle H1, H2 \in \text{gen}(\text{KSFTM}), \{T_i, T_j\} \subseteq H1, H2.\text{txns} : (H1 \sqsubseteq H2) \wedge (T_j \in H1.\text{committed}) \wedge (T_i \in H1.\text{live}) \implies (H2.\text{tll}_j < H2.\text{comTime}_i) \rangle$.

Proof. As observed in the previous proof of Lemma 36, if T_i is live or aborted in $H2$, then its $comTime$ is ∞ . In both these cases, the result follows.

If T_i is committed in $H2$ then, one can see that $comTime$ of T_i is not ∞ . In this case, it can be seen that T_j committed before T_i . Hence, we have that $comTime_j < comTime_i$. From Lemma 36, we get that $tltl_j \leq comTime_j$. This implies that $tltl_j < comTime_i$.

In the following sequence of lemmas, we identify the condition by when a transaction will commit.

Lemma 39 Consider two histories $H1, H3$ such that $H3$ is a strict extension of $H1$. Let T_i be a transaction in $H1$. live such that T_i itsEnabled in $H1$ and G_valid_i flag is true in $H1$. Suppose T_i is aborted in $H3$. Then there is a history $H2$ which is an extension of $H1$ (and could be same as $H1$) such that (1) Transaction T_i is live in $H2$; (2) there is a transaction T_j that is live in $H2$; (3) $H2.wts_j$ is greater than $H2.wts_i$; (4) T_j is committed in $H3$. Formally, $\langle H1, H3, T_i : (H1 \sqsubset H3) \wedge (T_i \in H1.live) \wedge (H1.valid_i = True) \wedge (H1.itsEnabled(T_i)) \wedge (T_i \in H3.aborted) \rangle \implies (\exists H2, T_j : (H1 \sqsubseteq H2 \sqsubset H3) \wedge (T_i \in H2.live) \wedge (T_j \in H2.txns) \wedge (H2.wts_i < H2.wts_j) \wedge (T_j \in H3.committed))$.

Proof. To show this lemma, w.l.o.g we assume that T_i on executing either read or $stm\text{-}tryC$ in $H2$ (which could be same as $H1$) gets aborted resulting in $H3$. Thus, we have that T_i is live in $H2$. Here T_i is itsEnabled in $H1$. From Lemma 34, we get that T_i is itsEnabled in $H2$ as well.

Let us sequentially consider all the lines where a T_i could abort. In $H2$, T_i executes one of the following lines and is aborted in $H3$. We start with $stm\text{-}tryC$ method.

1. STM $stm\text{-}tryC$:

- (a) Line 3 : This line invokes $abort()$ method on T_i which releases all the locks and returns \mathcal{A} to the invoking thread. Here T_i is aborted because its valid flag, is set to false by some other transaction, say T_j , in its $stm\text{-}tryC$ algorithm. This can occur in Lines: 45, 74 where T_i is added to T_j 's $abortRL$ set. Later in Line 94, T_i 's valid flag is set to false. Note that T_i 's valid is true (after the execution of the last event) in $H1$. Thus, T_i 's valid flag must have been set to false in an extension of $H1$, which we again denote as $H2$.

This can happen only if in both the above cases, T_j is live in $H2$ and its ITS is less than T_i 's ITS. But we have that T_i 's itsEnabled in $H2$. As a result, it has the smallest among all live and aborted transactions of $H2$. Hence, there cannot exist such a T_j which is live and $H2.its_j < H2.its_i$. Thus, this case is not possible.

- (b) Line 15: This line is executed in $H2$ if there exists no version of x whose τ_{ss} is less than T_i 's WTS. This implies that all the versions of x have τ_{ss} greater than wts_i . Thus the transactions that created these versions have WTS greater than wts_i and have already committed in $H2$. Let T_j create one such version. Hence, we have that $\langle (T_j \in H2.committed) \implies (T_j \in H3.committed) \rangle$ since $H3$ is an extension of $H2$.
- (c) Line 34 : This case is similar to Case 1a, i.e., Line 3.
- (d) Line 47 : In this line, T_i is aborted as some other transaction T_j in T_i 's $largeRL$ has committed. Any transaction in T_i 's $largeRL$ has WTS greater than T_i 's WTS. This implies that T_j is already committed in $H2$ and hence committed in $H3$ as well.
- (e) Line 64 : In this line, T_i is aborted because its lower limit has crossed its upper limit. First, let us consider $tutl_i$. It is initialized in $stm\text{-}begin$ method to ∞ . As long as it is ∞ , these limits cannot cross each other. Later, $tutl_i$ is updated in Line 17 of read method, Line 58 & Line 62 of $stm\text{-}tryC$ method. Suppose $tutl_i$ gets decremented to some value α by one of these lines.
Now there are two cases here: (1) Suppose $tutl_i$ gets decremented to $comTime_i$ due to Line 62 of $stm\text{-}tryC$ method. Then from Lemma 36, we have $tltl_i \leq comTime_i = tutl_i$. Thus in this case, T_i will not abort. (2) $tutl_i$ gets decremented to α which is less than $comTime_i$. Then from Lemma 37, we get that there is a committed transaction T_j in $H2.committed$ such that $wts_j > wts_i$. This implies that T_j is in $H3.committed$.
- (f) Line 76: This case is similar to Case 1a, i.e., Line 3.
- (g) Line 79 : In this case, T_k is in T_i 's $smallRL$ and is committed in $H1$. And, from this case, we have that

$$H2.tutl_i \leq H2.ttl_k \tag{6}$$

From the assumption of this case, we have that T_k commits before T_i . Thus, from Lemma 38, we get that $comTime_k < comTime_i$. From Lemma 36, we have that $ttl_k \leq comTime_k$. Thus, we get that $ttl_k < comTime_i$. Combining this with the inequality of this case Eq.(6), we get that $tutl_i < comTime_i$.

Combining this inequality with Lemma 37, we get that there is a transaction T_j in $H2.committed$ and $H2.wts_j > H2.wts_i$. This implies that T_j is in $H3.committed$ as well.

2. STM read:

- (a) Line 7: This case is similar to Case 1a, i.e., Line 3
- (b) Line 22: The reasoning here is similar to Case 1e, i.e., Line 64.

The interesting aspect of the above lemma is that it gives us a insight as to when a T_i will get commit. If an itsEnabled transaction T_i aborts then it is because of another transaction T_j with WTS higher than T_i has committed. To precisely capture this, we define two more notions of a transaction being enabled *cdsEnabled* and *finEnabled*. To define these notions of enabled, we in turn define a few other auxiliary notions. We start with *affectSet*,

$$H.affectSet(T_i) = \{T_j | (T_j \in H.txns) \wedge (H.its_j < H.its_i + 2 * L)\}$$

From the description of *KSFTM* algorithm and Lemma 33, it can be seen that a transaction T_i 's commit can depend on committing of transactions (or their incarnations) which have their ITS less than ITS of $T_i + 2*L$, which is T_i 's *affectSet*. We capture this notion of dependency for a transaction T_i in a history H as *commit dependent set* or *cds* as: the set of all transactions T_j in T_i 's *affectSet* that do not any incarnation that is committed yet, i.e., not yet have their *incarCt* flag set as true. Formally,

$$H.cds(T_i) = \{T_j | (T_j \in H.affectSet(T_i)) \wedge (\neg H.incarCt(T_j))\}$$

Based on this definition of *cds*, we next define the notion of *cdsEnabled*.

Definition 3 We say that transaction T_i is *cdsEnabled* if the following conditions hold true (1) T_i is live in H ; (2) *CTS* of T_i is greater than or equal to *ITS* of $T_i + 2 * L$; (3) *cds* of T_i is empty, i.e., for all transactions T_j in H with *ITS* lower than *ITS* of $T_i + 2 * L$ in H have their *incarCt* to be true. Formally,

$$H.cdsEnabled(T_i) = \begin{cases} True & (T_i \in H.live) \wedge (H.cts_i \geq H.its_i + 2 * L) \wedge (H.cds(T_i) = \phi) \\ False & otherwise \end{cases}$$

The meaning and usefulness of these definitions will become clear in the course of the proof. In fact, we later show that once the transaction T_i is *cdsEnabled*, it will eventually commit. We will start with a few lemmas about these definitions.

Lemma 40 Consider a transaction T_i in a history H . If T_i is *cdsEnabled* then T_i is also *itsEnabled*. Formally, $\langle H, T_i : (T_i \in H.txns) \wedge (H.cdsEnabled(T_i)) \implies (H.itsEnabled(T_i)) \rangle$.

Proof. If T_i is *cdsEnabled* in H then it implies that T_i is live in H . From the definition of *cdsEnabled*, we get that $H.cds(T_i)$ is ϕ implying that any transaction T_j with *its_k* less than *its_i + 2 * L* has its *incarCt* flag as true in H . Hence, for any transaction T_k having *its_k* less than *its_i*, $H.incarCt(T_k)$ is also true. This shows that T_i is *itsEnabled* in H .

Lemma 41 Consider a transaction T_i which is *cdsEnabled* in a history $H1$. Consider an extension of $H1$, $H2$ with a transaction T_j in it such that T_i is an incarnation of T_j . Let T_k be a transaction in the *affectSet* of T_j in $H2$ Then T_k is also in the set of transaction of $H1$. Formally, $\langle H1, H2, T_i, T_j, T_k : (H1 \sqsubseteq H2) \wedge (H1.cdsEnabled(T_i)) \wedge (T_i \in H2.incarSet(T_j)) \wedge (T_k \in H2.affectSet(T_j)) \implies (T_k \in H1.txns) \rangle$

Proof. Since T_i is cdsEnabled in $H1$, we get (from the definition of cdsEnabled) that

$$H1.cts_i \geq H1.its_i + 2 * L \quad (7)$$

Here, we have that T_k is in $H2.affectSet(T_j)$. Thus from the definition of affectSet, we get that

$$H2.its_k < H2.its_j + 2 * L \quad (8)$$

Since T_i and T_j are incarnations of each other, their ITS are the same. Combining this with Eq.(8), we get that

$$H2.its_k < H1.its_i + 2 * L \quad (9)$$

We now show this proof through contradiction. Suppose T_k is not in $H1.txns$. Then there are two cases:

- No incarnation of T_k is in $H1$: This implies that T_k starts afresh after $H1$. Since T_k is not in $H1$, from Corollary 29 we get that

$$\begin{aligned} H2.cts_k > H1.sys-time &\xrightarrow{H2.cts_k=H2.its_k} \frac{T_k \text{ starts afresh}}{H2.cts_k=H2.its_k} H2.its_k > H1.sys-time \xrightarrow{H1.sys-time \geq H1.cts_i} \frac{(T_i \in H1) \wedge \text{Lemma 28}}{H1.sys-time \geq H1.cts_i} H2.its_k > \\ H1.cts_i &\xrightarrow{Eq.(7)} H2.its_k > H1.its_i + 2 * L \xrightarrow{H1.its_i=H2.its_j} H2.its_k > H2.its_j + 2 * L \end{aligned}$$

But this result contradicts with Eq.(8). Hence, this case is not possible.

- There is an incarnation of T_k, T_l in $H1$: In this case, we have that

$$H1.its_l = H2.its_k \quad (10)$$

Now combing this result with Eq.(9), we get that $H1.its_l < H1.its_i + 2 * L$. This implies that T_l is in affectSet of T_i in $H1$. Since T_i is cdsEnabled, we get that T_l 's incarCt must be true.

We also have that T_k is not in $H1$ but in $H2$ where $H2$ is an extension of $H1$. Since $H2$ has some events more than $H1$, we get that $H2$ is a strict extension of $H1$.

Thus, we have that, $(H1 \sqsubseteq H2) \wedge (H1.incarCt(T_l)) \wedge (T_k \in H2.txns) \wedge (T_k \notin H1.txns)$. Combining these with Lemma 21, we get that $(H1.its_l \neq H2.its_k)$. But this result contradicts Eq.(10). Hence, this case is also not possible.

Thus from both the cases we get that T_k should be in $H1$. Hence proved.

Lemma 42 Consider two histories $H1, H2$ where $H2$ is an extension of $H1$. Let T_i, T_j, T_k be three transactions such that T_i is in $H1.txns$ while T_j, T_k are in $H2.txns$. Suppose we have that (1) cts_i is greater than $its_i + 2 * L$ in $H1$; (2) T_i is an incarnation of T_j ; (3) T_k is in affectSet of T_j in $H2$. Then an incarnation of T_k , say T_l (which could be same as T_k) is in $H1.txns$. Formally, $\langle H1, H2, T_i, T_j, T_k : (H1 \sqsubseteq H2) \wedge (T_i \in H1.txns) \wedge (\{T_j, T_k\} \in H2.txns) \wedge (H1.cts_i > H1.its_i + 2 * L) \wedge (T_i \in H2.incarSet(T_j)) \wedge (T_k \in H2.affectSet(T_j)) \implies (\exists T_l : (T_l \in H2.incarSet(T_k)) \wedge (T_l \in H1.txns)) \rangle$

Proof.

This proof is similar to the proof of Lemma 41. We are given that

$$H1.cts_i \geq H1.its_i + 2 * L \quad (11)$$

We now show this proof through contradiction. Suppose no incarnation of T_k is in $H1.txns$. This implies that T_k must have started afresh in some history $H3$ which is an extension of $H1$. Also note that $H3$ could be same as $H2$ or a prefix of it, i.e., $H3 \sqsubseteq H2$. Thus, we have that

$$\begin{aligned} H3.its_k > H1.sys-time &\xrightarrow{\text{Lemma 28}} H3.its_k > H1.cts_i \xrightarrow{Eq.(11)} H3.its_k > H1.its_i + 2 * L \xrightarrow{H1.its_i=H2.its_j} \\ H3.its_k > H2.its_j + 2 * L &\xrightarrow{\text{Observation 23}} \frac{H3 \sqsubseteq H2}{\text{Observation 23}} H2.its_k > H2.its_j + 2 * L \xrightarrow{\text{affectSet definition}} T_k \notin H2.affectSet(T_j) \end{aligned}$$

But we are given that T_k is in affectSet of T_j in $H2$. Hence, it is not possible that T_k started afresh after $H1$. Thus, T_k must have an incarnation in $H1$.

Lemma 43 Consider a transaction T_i which is *cdsEnabled* in a history $H1$. Consider an extension of $H1$, $H2$ with a transaction T_j in it such that T_j is an incarnation of T_i in $H2$. Then *affectSet* of T_i in $H1$ is same as the *affectSet* of T_j in $H2$. Formally, $\langle H1, H2, T_i, T_j : (H1 \sqsubseteq H2) \wedge (H1.cdsEnabled(T_i)) \wedge (T_j \in H2.txns) \wedge (T_i \in H2.incarSet(T_j)) \rangle \implies ((H1.affectSet(T_i) = H2.affectSet(T_j)))$

Proof. From the definition of *cdsEnabled*, we get that T_i is in $H1.txns$. Now to prove that *affectSets* are the same, we have to show that $(H1.affectSet(T_i) \subseteq H2.affectSet(T_j))$ and $(H1.affectSet(T_j) \subseteq H2.affectSet(T_i))$. We show them one by one:

$(H1.affectSet(T_i) \subseteq H2.affectSet(T_j))$: Consider a transaction T_k in $H1.affectSet(T_i)$. We have to show that T_k is also in $H2.affectSet(T_j)$. From the definition of *affectSet*, we get that

$$T_k \in H1.txns \quad (12)$$

Combining Eq.(12) with Observation 23, we get that

$$T_k \in H2.txns \quad (13)$$

From the definition of ITS, we get that

$$H1.its_k = H2.its_k \quad (14)$$

Since T_i, T_j are incarnations we have that .

$$H1.its_i = H2.its_j \quad (15)$$

From the definition of *affectSet*, we get that,

$$H1.its_k < H1.its_i + 2 * L \xrightarrow{Eq.(14)} H2.its_k < H1.its_i + 2 * L \xrightarrow{Eq.(15)} H2.its_k < H2.its_j + 2 * L$$

Combining this result with Eq.(13), we get that $T_k \in H2.affectSet(T_j)$.

$(H1.affectSet(T_i) \subseteq H2.affectSet(T_j))$: Consider a transaction T_k in $H2.affectSet(T_j)$. We have to show that T_k is also in $H1.affectSet(T_i)$. From the definition of *affectSet*, we get that $T_k \in H2.txns$.

Here, we have that $(H1 \sqsubseteq H2) \wedge (H1.cdsEnabled(T_i)) \wedge (T_i \in H2.incarSet(T_j)) \wedge (T_k \in H2.affectSet(T_j))$. Thus from Lemma 41, we get that $T_k \in H1.txns$. Now, this case is similar to the above case. It can be seen that Equations 12, 13, 14, 15 hold good in this case as well.

Since T_k is in $H2.affectSet(T_j)$, we get that

$$H2.its_k < H2.its_j + 2 * L \xrightarrow{Eq.(14)} H1.its_k < H2.its_j + 2 * L \xrightarrow{Eq.(15)} H1.its_k < H1.its_i + 2 * L$$

Combining this result with Eq.(12), we get that $T_k \in H1.affectSet(T_i)$.

Next we explore how a *cdsEnabled* transaction remains *cdsEnabled* in the future histories once it becomes true.

Lemma 44 Consider two histories $H1$ and $H2$ with $H2$ being an extension of $H1$. Let T_i and T_j be two transactions which are live in $H1$ and $H2$ respectively. Let T_i be an incarnation of T_j and cts_i is less than cts_j . Suppose T_i is *cdsEnabled* in $H1$. Then T_j is *cdsEnabled* in $H2$ as well. Formally, $\langle H1, H2, T_i, T_j : (H1 \sqsubseteq H2) \wedge (T_i \in H1.live) \wedge (T_j \in H2.live) \wedge (T_i \in H2.incarSet(T_j)) \wedge (H1.cts_i < H2.cts_j) \wedge (H1.cdsEnabled(T_i)) \rangle \implies (H2.cdsEnabled(T_j))$.

Proof. We have that T_i is live in $H1$ and T_j is live in $H2$. Since T_i is *cdsEnabled* in $H1$, we get (from the definition of *cdsEnabled*) that

$$H1.cts_i \geq H2.its_i + 2 * L \quad (16)$$

We are given that cts_i is less than cts_j and T_i, T_j are incarnations of each other. Hence, we have that

$$\begin{aligned} H2.cts_j &> H1.cts_i \\ &> H1.its_i + 2 * L && \text{[From Eq.(16)]} \\ &> H2.its_j + 2 * L && [its_i = its_j] \end{aligned}$$

Thus we get that $cts_j > its_j + 2 * L$. We have that T_j is live in $H2$. In order to show that T_j is cdsEnabled in $H2$, it only remains to show that cds of T_j in $H2$ is empty, i.e., $H2.cds(T_j) = \phi$. The cds becomes empty when all the transactions of T_j 's affectSet in $H2$ have their incarCt as true in $H2$.

Since T_j is live in $H2$, we get that T_j is in $H2.txns$. Here, we have that $(H1 \sqsubseteq H2) \wedge (T_j \in H2.txns) \wedge (T_i \in H2.incarSet(T_j)) \wedge (H1.cdsEnabled(T_i))$. Combining this with Lemma 43, we get that $H1.affectSet(T_i) = H2.affectSet(T_j)$.

Now, consider a transaction T_k in $H2.affectSet(T_j)$. From the above result, we get that T_k is also in $H1.affectSet(T_i)$. Since T_i is cdsEnabled in $H1$, i.e., $H1.cdsEnabled(T_i)$ is true, we get that $H1.incarCt(T_k)$ is true. Combining this with Observation 20, we get that T_k must have its incarCt as true in $H2$ as well, i.e. $H2.incarCt(T_k)$. This implies that all the transactions in T_j 's affectSet have their incarCt flags as true in $H2$. Hence the $H2.cds(T_j)$ is empty. As a result, T_j is cdsEnabled in $H2$, i.e., $H2.cdsEnabled(T_j)$.

Having defined the properties related to cdsEnabled, we start defining notions for finEnabled. Next, we define $maxWTS$ for a transaction T_i in H which is the transaction T_j with the largest WTS in T_i 's incarSet. Formally,

$$H.maxWTS(T_i) = \max\{H.wts_j | (T_j \in H.incarSet(T_i))\}$$

From this definition of maxWTS, we get the following simple observation.

Observation 45 For any transaction T_i in H , we have that wts_i is less than or equal to $H.maxWTS(T_i)$. Formally, $H.wts_i \leq H.maxWTS(T_i)$.

Next, we combine the notions of affectSet and maxWTS to define $affWTS$. It is the maximum of maxWTS of all the transactions in its affectSet. Formally,

$$H.affWTS(T_i) = \max\{H.maxWTS(T_j) | (T_j \in H.affectSet(T_i))\}$$

Having defined the notion of affWTS, we get the following lemma relating the affectSet and affWTS of two transactions.

Lemma 46 Consider two histories $H1$ and $H2$ with $H2$ being an extension of $H1$. Let T_i and T_j be two transactions which are live in $H1$ and $H2$ respectively. Suppose the affectSet of T_i in $H1$ is same as affectSet of T_j in $H2$. Then the affWTS of T_i in $H1$ is same as affWTS of T_j in $H2$. Formally, $\langle H1, H2, T_i, T_j : (H1 \sqsubseteq H2) \wedge (T_i \in H1.txns) \wedge (T_j \in H2.txns) \wedge (H1.affectSet(T_i) = H2.affectSet(T_j)) \implies (H1.affWTS(T_i) = H2.affWTS(T_j)) \rangle$.

Proof.

From the definition of affWTS, we get the following equations

$$H.affWTS(T_i) = \max\{H.maxWTS(T_k) | (T_k \in H1.affectSet(T_i))\} \quad (17)$$

$$H.affWTS(T_j) = \max\{H.maxWTS(T_l) | (T_l \in H2.affectSet(T_j))\} \quad (18)$$

From these definitions, let us suppose that $H1.affWTS(T_i)$ is $H1.maxWTS(T_p)$ for some transaction T_p in $H1.affectSet(T_i)$. Similarly, suppose that $H2.affWTS(T_j)$ is $H2.maxWTS(T_q)$ for some transaction T_q in $H2.affectSet(T_j)$.

Here, we are given that $H1.affectSet(T_i) = H2.affectSet(T_j)$. Hence, we get that T_p is also in $H1.affectSet(T_i)$. Similarly, T_q is in $H2.affectSet(T_j)$ as well. Thus from Equations (17) & (18), we get that

$$H1.maxWTS(T_p) \geq H2.maxWTS(T_q) \quad (19)$$

$$H2.maxWTS(T_q) \geq H1.maxWTS(T_p) \quad (20)$$

Combining these both equations, we get that $H1.maxWTS(T_p) = H2.maxWTS(T_q)$ which in turn implies that $H1.affWTS(T_i) = H2.affWTS(T_j)$.

Finally, using the notion of affWTS and cdsEnabled, we define the notion of *finEnabled*

Definition 4 We say that transaction T_i is *finEnabled* if the following conditions hold true (1) T_i is live in H ; (2) T_i is *cdsEnabled* in H ; (3) $H.wts_j$ is greater than $H.affWTS(T_i)$. Formally,

$$H.finEnabled(T_i) = \begin{cases} True & (T_i \in H.live) \wedge (H.cdsEnabled(T_i)) \wedge (H.wts_j > H.affWTS(T_i)) \\ False & otherwise \end{cases}$$

It can be seen from this definition, a transaction that is *finEnabled* is also *cdsEnabled*. We now show that just like *itsEnabled* and *cdsEnabled*, once a transaction is *finEnabled*, it remains *finEnabled* until it terminates. The following lemma captures it.

Lemma 47 Consider two histories $H1$ and $H2$ with $H2$ being an extension of $H1$. Let T_i and T_j be two transactions which are live in $H1$ and $H2$ respectively. Suppose T_i is *finEnabled* in $H1$. Let T_i be an incarnation of T_j and cts_i is less than cts_j . Then T_j is *finEnabled* in $H2$ as well. Formally, $\langle (H1 \sqsubseteq H2) \wedge (T_i \in H1.live) \wedge (T_j \in H2.live) \wedge (T_i \in H2.incarSet(T_j)) \wedge (H1.cts_i < H2.cts_j) \wedge (H1.finEnabled(T_i)) \implies (H2.finEnabled(T_j)) \rangle$.

Proof. Here we are given that T_j is live in $H2$. Since T_i is *finEnabled* in $H1$, we get that it is *cdsEnabled* in $H1$ as well. Combining this with the conditions given in the lemma statement, we have that,

$$\langle (H1 \sqsubseteq H2) \wedge (T_i \in H1.live) \wedge (T_j \in H2.live) \wedge (T_i \in H2.incarSet(T_j)) \wedge (H1.cts_i < H2.cts_j) \wedge (H1.cdsEnabled(T_i)) \rangle \quad (21)$$

Combining Eq.(21) with Lemma 44, we get that T_j is *cdsEnabled* in $H2$, i.e., $H2.cdsEnabled(T_j)$. Now, in order to show that T_j is *finEnabled* in $H2$ it remains for us to show that $H2.wts_j > H2.affWTS(T_j)$.

We are given that T_j is live in $H2$ which in turn implies that T_j is in $H2.txns$. Thus changing this in Eq.(21), we get the following

$$\langle (H1 \sqsubseteq H2) \wedge (T_j \in H2.txns) \wedge (T_i \in H2.incarSet(T_j)) \wedge (H1.cts_i < H2.cts_j) \wedge (H1.cdsEnabled(T_i)) \rangle \quad (22)$$

Combining Eq.(22) with Lemma 43 we get that

$$H1.affWTS(T_i) = H2.affWTS(T_j) \quad (23)$$

We are given that $H1.cts_i < H2.cts_j$. Combining this with the definition of WTS, we get

$$H1.wts_i < H2.wts_j \quad (24)$$

Since T_i is *finEnabled* in $H1$, we have that

$$H1.wts_i > H1.affWTS(T_i) \xrightarrow{Eq.(24)} H2.wts_j > H1.affWTS(T_i) \xrightarrow{Eq.(23)} H2.wts_j > H2.affWTS(T_j)$$

Now, we show that a transaction that is *finEnabled* will eventually commit.

Lemma 48 Consider a live transaction T_i in a history $H1$. Suppose T_i is *finEnabled* in $H1$ and $valid_i$ is true in $H1$. Then there exists an extension of $H1$, $H3$ in which T_i is committed. Formally, $\langle (H1, T_i : (T_i \in H1.live) \wedge (H1.valid_i) \wedge (H1.finEnabled(T_i)) \implies (\exists H3 : (H1 \sqsubset H3) \wedge (T_i \in H3.committed)) \rangle$.

Proof. Consider a history $H3$ such that its sys-time being greater than $cts_i + L$. We will prove this lemma using contradiction. Suppose T_i is aborted in $H3$.

Now consider T_i in $H1$: T_i is live; its valid flag is true; and is *finEnabled*. From the definition of *finEnabled*, we get that it is also *cdsEnabled*. From Lemma 40, we get that T_i is *itsEnabled* in $H1$. Thus from Lemma 39, we get that there exists an extension of $H1$, $H2$ such that (1) Transaction T_i is live in $H2$; (2) there is a transaction T_j in $H2$; (3) $H2.wts_j$ is greater than $H2.wts_i$; (4) T_j is committed in $H3$. Formally,

$$\langle (\exists H2, T_j : (H1 \sqsubseteq H2 \sqsubset H3) \wedge (T_i \in H2.live) \wedge (T_j \in H2.txns) \wedge (H2.wts_i < H2.wts_j) \wedge (T_j \in H3.committed)) \rangle \quad (25)$$

Here, we have that $H2$ is an extension of $H1$ with T_i being live in both of them and T_i is `finEnabled` in $H1$. Thus from Lemma 47, we get that T_i is `finEnabled` in $H2$ as well. Now, let us consider T_j in $H2$. From Eq.(25), we get that $(H2.wts_i < H2.wts_j)$. Combining this with the observation that T_i being live in $H2$, Lemma 33 we get that $(H2.its_j \leq H2.its_i + 2 * L)$.

This implies that T_j is in `affectSet` of T_i in $H2$, i.e., $(T_j \in H2.affectSet(T_i))$. From the definition of `affWTS`, we get that

$$(H2.affWTS(T_i) \geq H2.maxWTS(T_j)) \quad (26)$$

Since T_i is `finEnabled` in $H2$, we get that wts_i is greater than `affWTS` of T_i in $H2$.

$$(H2.wts_i > H2.affWTS(T_i)) \quad (27)$$

Now combining Equations 26, 27 we get,

$$\begin{aligned} H2.wts_i &> H2.affWTS(T_i) \geq H2.maxWTS(T_j) \\ &> H2.affWTS(T_i) \geq H2.maxWTS(T_j) \geq H2.wts_j && \text{[From Observation 45]} \\ &> H2.wts_j \end{aligned}$$

But this equation contradicts with Eq.(25). Hence our assumption that T_i will get aborted in $H3$ after getting `finEnabled` is not possible. Thus T_i has to commit in $H3$.

Next we show that once a transaction T_i becomes `itsEnabled`, it will eventually become `finEnabled` as well and then committed. We show this change happens in a sequence of steps. We first show that Transaction T_i which is `itsEnabled` first becomes `cdsEnabled` (or gets committed). We next show that T_i which is `cdsEnabled` becomes `finEnabled` or get committed. On becoming `finEnabled`, we have already shown that T_i will eventually commit.

Now, we show that a transaction that is `itsEnabled` will become `cdsEnabled` or committed. To show this, we introduce a few more notations and definitions. We start with the notion of *depIts* (*dependent-its*) which is the set of ITSs that a transaction T_i depends on to commit. It is the set of ITS of all the transactions in T_i 's `cds` in a history H . Formally,

$$H.depIts(T_i) = \{H.its_j | T_j \in H.cds(T_i)\}$$

We have the following lemma on the `depIts` of a transaction T_i and its future incarnation T_j which states that `depIts` of a T_i either reduces or remains the same.

Lemma 49 Consider two histories $H1$ and $H2$ with $H2$ being an extension of $H1$. Let T_i and T_j be two transactions which are live in $H1$ and $H2$ respectively and T_i is an incarnation of T_j . In addition, we also have that cts_i is greater than $its_i + 2 * L$ in $H1$. Then, we get that $H2.depIts(T_j)$ is a subset of $H1.depIts(T_i)$. Formally, $\langle H1, H2, T_i, T_j : (H1 \sqsubseteq H2) \wedge (T_i \in H1.live) \wedge (T_j \in H2.live) \wedge (T_i \in H2.incarSet(T_j)) \wedge (H1.cts_i \geq H1.its_i + 2 * L) \implies (H2.depIts(T_j) \subseteq H1.depIts(T_i)) \rangle$.

Proof. Suppose $H2.depIts(T_j)$ is not a subset of $H1.depIts(T_i)$. This implies that there is a transaction T_k such that $H2.its_k \in H2.depIts(T_j)$ but $H1.its_k \notin H1.depIts(T_j)$. This implies that T_k starts afresh after $H1$ in some history say $H3$ such that $H1 \sqsubset H3 \sqsubseteq H2$. Hence, from Corollary 29 we get the following

$$\begin{aligned} H3.its_k > H1.sys-time &\xrightarrow{\text{Lemma 28}} H3.its_k > H1.cts_i \implies H3.its_k > H1.its_i + 2 * L \xrightarrow{H1.its_i = H2.its_j} \\ H3.its_k > H2.its_j + 2 * L &\xrightarrow[\text{definitions}]{\text{affectSet, depIts}} H2.its_k \notin H2.depIts(T_j) \end{aligned}$$

We started with its_k in $H2.depIts(T_j)$ and ended with its_k not in $H2.depIts(T_j)$. Thus, we have a contradiction. Hence, the lemma follows.

Next we denote the set of committed transactions in T_i 's `affectSet` in H as *cis* (*commit independent set*). Formally,

$$H.cis(T_i) = \{T_j | (T_j \in H.affectSet(T_i)) \wedge (H.incarCt(T_j))\}$$

In other words, we have that $H.cis(T_i) = H.affectSet(T_i) - H.cds(T_i)$. Finally, using the notion of *cis* we denote the maximum of `maxWTS` of all the transactions in T_i 's *cis* as *partAffWTS* (partly affecting WTS). It turns out that the value of `partAffWTS` affects the commit of T_i which we show in the course of the proof. Formally, `partAffWTS` is defined as

$$H.partAffWTS(T_i) = \max\{H.maxWTS(T_j) \mid (T_j \in H.cis(T_i))\}$$

Having defined the required notations, we are now ready to show that a `itsEnabled` transaction will eventually become `cdsEnabled`.

Lemma 50 Consider a transaction T_i which is live in a history $H1$ and cts_i is greater than or equal to $its_i + 2 * L$. If T_i is `itsEnabled` in $H1$ then there is an extension of $H1$, $H2$ in which an incarnation T_i, T_j (which could be same as T_i), is either committed or `cdsEnabled`. Formally, $\langle H1, T_i : (T_i \in H1.live) \wedge (H1.cts_i \geq H1.its_i + 2 * L) \wedge (H1.itsEnabled(T_i)) \implies (\exists H2, T_j : (H1 \sqsubset H2) \wedge (T_j \in H2.incarSet(T_i)) \wedge ((T_j \in H2.committed) \vee (H2.cdsEnabled(T_j)))) \rangle$.

Proof. We prove this by inducting on the size of $H1.depIts(T_i)$, n . For showing this, we define a boolean function $P(k)$ as follows:

$$P(k) = \begin{cases} True & \langle H1, T_i : (T_i \in H1.live) \wedge (H1.cts_i \geq H1.its_i + 2 * L) \wedge (H1.itsEnabled(T_i)) \wedge \\ & (k \geq |H1.depIts(T_i)|) \implies (\exists H2, T_j : (H1 \sqsubset H2) \wedge (T_j \in H2.incarSet(T_i)) \wedge \\ & ((T_j \in H2.committed) \vee (H2.cdsEnabled(T_j)))) \rangle \\ False & \text{otherwise} \end{cases}$$

As can be seen, here $P(k)$ means that if (1) T_i is live in $H1$; (2) cts_i is greater than or equal to $its_i + 2 * L$; (3) T_i is `itsEnabled` in $H1$ (4) the size of $H1.depIts(T_i)$ is less than or equal to k ; then there exists a history $H2$ with a transaction T_j in it which is an incarnation of T_i such that T_j is either committed or `cdsEnabled` in $H2$. We show $P(k)$ is true for all (integer) values of k using induction.

Base Case - $P(0)$: Here, from the definition of $P(0)$, we get that $|H1.depIts(T_i)| = 0$. This in turn implies that $H1.cds(T_i)$ is null. Further, we are already given that T_i is live in $H1$ and $H1.cts_i \geq H1.its_i + 2 * L$. Hence, all these imply that T_i is `cdsEnabled` in $H1$.

Induction case - To prove $P(k + 1)$ given that $P(k)$ is true: If $|H1.depIts(T_i)| \leq k$, from the induction hypothesis $P(k)$, we get that T_j is either committed or `cdsEnabled` in $H2$. Hence, we consider the case when

$$|H1.depIts(T_i)| = k + 1 \tag{28}$$

Let α be $H1.partAffWTS(T_i)$. Suppose $H1.wts_i < \alpha$. Then from Lemma 27, we get that there is an extension of $H1$, say $H3$ in which an incarnation of T_i, T_l (which could be same as T_i) is committed or is live in $H3$ and has WTS greater than α . If T_l is committed then $P(k + 1)$ is trivially true. So we consider the latter case in which T_l is live in $H3$. In case $H1.wts_i \geq \alpha$, then in the analysis below follow where we can replace T_l with T_i .

Next, suppose T_l is aborted in an extension of $H3$, $H5$. Then from Lemma 39, we get that there exists an extension of $H3$, $H4$ in which (1) T_l is live; (2) there is a transaction T_m in $H4.txns$; (3) $H4.wts_m > H4.wts_l$ (4) T_m is committed in $H5$.

Combining the above derived conditions (1), (2), (3) with Lemma 36 we get that in $H4$,

$$H4.its_m \leq H4.its_l + 2 * L \tag{29}$$

Eq.(29) implies that T_m is in T_l 's `affectSet`. Here, we have that T_l is an incarnation of T_i and we are given that $H1.cts_i \geq H1.its_i + 2 * L$. Thus from Lemma 42, we get that there exists an incarnation of T_m, T_n in $H1$.

Combining Eq.(29) with the observations (a) T_n, T_m are incarnations; (b) T_l, T_i are incarnations; (c) T_i, T_n are in $H1.txns$, we get that $H1.its_n \leq H1.its_i + 2 * L$. This implies that T_n is in $H1.affectSet(T_i)$. Since T_n is not committed in $H1$ (otherwise, it is not possible for T_m to be an incarnation of T_n), we get that T_n is in $H1.cds(T_i)$. Hence, we get that $H4.its_m = H1.its_n$ is in $H1.depIts(T_i)$.

From Eq.(28), we have that $H1.depIts(T_i)$ is $k + 1$. From Lemma 49, we get that $H4.depIts(T_i)$ is a subset of $H1.depIts(T_i)$. Further, we have that transaction T_m has committed. Thus $H4.its_m$ which was in $H1.depIts(T_i)$ is no longer in $H4.depIts(T_i)$. This implies that $H4.depIts(T_i)$ is a strict subset of $H1.depIts(T_i)$ and hence $|H4.depIts(T_i)| \leq k$.

Since T_i and T_l are incarnations, we get that $H4.depIts(T_i) = H1.depIts(T_l)$. Thus, we get that

$$|H4.depIts(T_i)| \leq k \implies |H4.depIts(T_l)| \leq k \tag{30}$$

Further, we have that T_l is a later incarnation of T_i . So, we get that

$$H4.cts_l > H4.cts_i \xrightarrow{\text{given}} H4.cts_l > H4.its_i + 2 * L \xrightarrow{H4.its_i = H4.its_l} H4.cts_l > H4.its_l + 2 * L \quad (31)$$

We also have that T_i is live in $H4$. Combining this with Equations 30, 31 and given the induction hypothesis that $P(k)$ is true, we get that there exists a history extension of $H4$, $H6$ in which an incarnation of T_i (also T_i), T_p is either committed or cdsEnabled. This proves the lemma.

Lemma 51 Consider a transaction T_i in a history $H1$. If T_i is cdsEnabled in $H1$ then there is an extension of $H1$, $H2$ in which an incarnation T_i, T_j (which could be same as T_i), is either committed or finEnabled. Formally, $\langle H1, T_i : (T_i \in H1.live) \wedge (H1.cdsEnabled(T_i)) \implies (\exists H2, T_j : (H1 \sqsubset H2) \wedge (T_j \in H2.incarSet(T_i)) \wedge ((T_j \in H2.committed) \vee (H2.finEnabled(T_j)))) \rangle$.

Proof. In $H1$, suppose $H1.affWTS(T_i)$ is α . From Lemma 27, we get that there is a extension of $H1$, $H2$ with a transaction T_j which is an incarnation of T_i . Here there are two cases: (1) Either T_j is committed in $H2$. This trivially proves the lemma; (2) Otherwise, wts_j is greater than α .

In the second case, we get that

$$(T_i \in H1.live) \wedge (T_j \in H2.live) \wedge (H.cdsEnabled(T_i)) \wedge (T_j \in H2.incarSet(T_i)) \wedge (H1.wts_i < H2.wts_j) \quad (32)$$

Combining the above result with Lemma 26, we get that $H1.cts_i < H2.cts_j$. Thus the modified equation is

$$(T_i \in H1.live) \wedge (T_j \in H2.live) \wedge (H1.cdsEnabled(T_i)) \wedge (T_j \in H2.incarSet(T_i)) \wedge (H1.cts_i < H2.cts_j) \quad (33)$$

Next combining Eq.(33) with Lemma 43, we get that

$$H1.affectSet(T_i) = H2.affectSet(T_j) \quad (34)$$

Similarly, combining Eq.(33) with Lemma 44 we get that T_j is cdsEnabled in $H2$ as well. Formally,

$$H2.cdsEnabled(T_j) \quad (35)$$

Now combining Eq.(34) with Lemma 46, we get that

$$H1.affWTS(T_i) = H2.affWTS(T_j) \quad (36)$$

From our initial assumption we have that $H1.affWTS(T_i)$ is α . From Eq.(36), we get that $H2.affWTS(T_j) = \alpha$. Further, we had earlier also seen that $H2.wts_j$ is greater than α . Hence, we have that $H2.wts_j > H2.affWTS(T_j)$. Combining the above result with Eq.(35), $H2.cdsEnabled(T_j)$, we get that T_j is finEnabled, i.e., $H2.finEnabled(T_j)$.

Next, we show that every live transaction eventually become itsEnabled.

Lemma 52 Consider a history $H1$ with T_i be a transaction in $H1.live$. Then there is an extension of $H1$, $H2$ in which an incarnation of T_i, T_j (which could be same as T_i) is either committed or is itsEnabled. Formally, $\langle H1, T_i : (T_i \in H1.live) \implies (\exists T_j, H2 : (H1 \sqsubset H2) \wedge (T_j \in H2.incarSet(T_i)) \wedge (T_j \in H2.committed) \vee (H.itsEnabled(T_i))) \rangle$.

Proof. We prove this lemma by inducting on ITS.

Base Case - $its_i = 1$: In this case, T_i is the first transaction to be created. There are no transactions with smaller ITS. Thus T_i is trivially itsEnabled.

Induction Case: Here we assume that for any transaction $its_i \leq k$ the lemma is true.

Combining these lemmas gives us the result that for every live transaction T_i there is an incarnation T_j (which could be the same as T_i) that will commit. This implies that every application-transaction eventually commits. The follow lemma captures this notion.

Theorem 53 Consider a history $H1$ with T_i be a transaction in $H1.live$. Then there is an extension of $H1$, $H2$ in which an incarnation of T_i , T_j is committed. Formally, $\langle H1, T_i : (T_i \in H1.live) \implies (\exists T_j, H2 : (H1 \sqsubset H2) \wedge (T_j \in H2.incarSet(T_i)) \wedge (T_j \in H2.committed)) \rangle$.

Proof. Here we show the states that a transaction T_i (or one of its incarnations) undergoes before it commits. In all these transitions, it is possible that an incarnation of T_i can commit. But to show the worst case, we assume that no incarnation of T_i commits. Continuing with this argument, we show that finally an incarnation of T_i commits.

Consider a live transaction T_i in $H1$. Then from Lemma 52, we get that there is a history $H2$, which is an extension of $H1$, in which T_j an incarnation of T_i is either committed or itsEnabled. If T_j is itsEnabled in $H2$, then from Lemma 50, we get that T_k , an incarnation of T_j , will be cdsEnabled in a extension of $H2$, $H3$ (assuming that T_k is not committed in $H3$).

From Lemma 51, we get that there is an extension of $H3$, $H4$ in which an incarnation of T_k , T_l will be finEnabled assuming that it is not committed in $H4$. Finally, from Lemma 48, we get that there is an extension of $H4$ in which T_m , an incarnation of T_l , will be committed. This proves our theorem.

7 Discussion and Conclusion

In this paper, we propose a K version *starvation-free* STM system, *KSFTM*. The algorithm ensures that if an *aborted* transaction is retried successively, then it will eventually commit. The algorithm maintains K versions where K can range from between one to infinity. For correctness, we show *KSFTM* satisfies strict-serializability [22] and local opacity [18, 19]. To the best of our knowledge, this is the first work to explore *starvation-freedom* with MVSTMs.

Our experiments show that *KSFTM* performs better than single-version STMs (ESTM, Norec STM) under high contention and also single-version *starvation-free* STM *SV-SFTM* developed based on the principle of priority. On the other hand, its performance is comparable or slightly worse than multi-version STM, *PKTO* (around 2%). This is the cost of the overhead required to achieve *starvation-freedom* which we believe is a marginal price.

In this document, we have not considered a transactional solution based on two-phase locking (2PL) and its multi-version variants [28]. With the carefully designed 2PL solution, one can ensure that none of the transactions abort [28]. But this will require advance knowledge of the code of the transactions which may not always be available with the STM library. Without such knowledge, it is possible that a 2PL solution can deadlock and cause further aborts which will, raise the issue of *starvation-freedom* again.

Since we have considered strict-serializable as one of the *correctness-criteria*, this algorithm can be extended to databases as well. In fact, to the best of our knowledge, there has been no prior work on *starvation-freedom* in the context of database concurrency control.

References

- [1] Utku Aydonat and Tarek S. Abdelrahman. Relaxed Concurrency Control in Software Transactional Memory. *IEEE Trans. Parallel Distrib. Syst.*, July 2012.
- [2] Philip A. Bernstein and Nathan Goodman. Multiversion Concurrency Control: Theory and Algorithms. *ACM Trans. Database Syst.*, December 1983.
- [3] Victor Bushkov and Rachid Guerraoui. Liveness in transactional memory. pages 32–49, 2015.
- [4] Victor Bushkov, Rachid Guerraoui, and Michal Kapalka. On the liveness of transactional memory. In *ACM Symposium on PODC 2012*, 2012.
- [5] Tyler Crain, Damien Imbs, and Michel Raynal. Read invisibility, virtual world consistency and probabilistic permissiveness are compatible. In *ICA3PP*, 2011.
- [6] Luke Dalessandro, Michael F. Spear, and Michael L. Scott. NOrec: Streamlining STM by Abolishing Ownership Records. *PPoPP 2010*, 2010.
- [7] Pascal Felber, Vincent Gramoli, and Rachid Guerraoui. Elastic transactions. *J. Parallel Distrib. Comput.*, 100(C):103–127, February 2017.

- [8] Sérgio Miguel Fernandes and Joao Cachopo. Lock-free and Scalable Multi-version Software Transactional Memory. *PPoPP 2011*, 2011.
- [9] Vincent Gramoli, Rachid Guerraoui, and Vasileios Trigonakis. TM2C: A Software Transactional Memory for Many-cores. *EuroSys 2012*, 2012.
- [10] Rachid Guerraoui, Thomas Henzinger, and Vasu Singh. Permissiveness in Transactional Memories. In *DISC 2008*, sep 2008.
- [11] Rachid Guerraoui and Michal Kapalka. On the Correctness of Transactional Memory. In *PPoPP 2008*.
- [12] Rachid Guerraoui and Michal Kapalka. *Principles of Transactional Memory, Synthesis Lectures on Distributed Computing Theory*. Morgan and Claypool, 2010.
- [13] Maurice Herlihy and J. Eliot B.Moss. Transactional memory: Architectural Support for Lock-Free Data Structures. *SIGARCH Comput. Archit. News*, 21(2), 1993.
- [14] Maurice Herlihy and Nir Shavit. On the nature of progress. *OPODIS 2011*, 2011.
- [15] Maurice Herlihy and Nir Shavit. *The Art of Multiprocessor Programming, Revised Reprint*. Morgan Kaufmann Publishers Inc., San Francisco, CA, USA, 1st edition, 2012.
- [16] Maurice P. Herlihy and Jeannette M. Wing. Linearizability: a correctness condition for concurrent objects. *ACM Trans. Program. Lang. Syst.*, 12(3), 1990.
- [17] Priyanka Kumar, Sathya Peri, and K. Vidyasankar. A TimeStamp Based Multi-version STM Algorithm. In *ICDCN*, pages 212–226, 2014.
- [18] Petr Kuznetsov and Sathya Peri. Non-interference and Local Correctness in Transactional Memory. In *ICDCN*, pages 197–211, 2014.
- [19] Petr Kuznetsov and Sathya Peri. Non-interference and local correctness in transactional memory. *Theor. Comput. Sci.*, 688, 2017.
- [20] Li Lu and Michael L. Scott. Generic multiversion STM. In *DISC 2013*, 2013.
- [21] Chi Cao Minh, JaeWoong Chung, Christos Kozyrakis, and Kunle Olukotun. STAMP: stanford transactional applications for multi-processing. In *IISWC 2008*.
- [22] Christos H. Papadimitriou. The serializability of concurrent database updates. *J. ACM*, 26(4), 1979.
- [23] Dmitri Perelman, Anton Byshevsky, Oleg Litmanovich, and Idit Keidar. SMV: Selective Multi-Versioning STM. In *DISC*, pages 125–140, 2011.
- [24] Torvald Riegel, Pascal Felber, and Christof Fetzer. A lazy snapshot algorithm with eager validation. In *DISC 2006*, 2006.
- [25] Nir Shavit and Dan Touitou. Software Transactional Memory. In *PODC*, 1995.
- [26] Michael F. Spear, Luke Dalessandro, Virendra J. Marathe, and Michael L. Scott. A comprehensive strategy for contention management in software transactional memory, 2009.
- [27] M. M. Waliullah and Per Stenström. Schemes for Avoiding Starvation in Transactional Memory Systems. *Concurrency and Computation: Practice and Experience*, 2009.
- [28] Gerhard Weikum and Gottfried Vossen. *Transactional Information Systems: Theory, Algorithms, and the Practice of Concurrency Control and Recovery*. Morgan Kaufmann, 2002.