

ATTENTION-BASED END-TO-END SPEECH RECOGNITION IN MANDARIN

Changhao Shan^{1,2}, Junbo Zhang², Yujun Wang², Lei Xie¹

¹Shaanxi Provincial Key Laboratory of Speech and Image Information Processing,
School of Computer Science, Northwestern Polytechnical University, Xi'an, China

²Xiaomi Inc., Beijing, China

{chshan, lxie}@nwpu-aslp.org, {zhangjunbo, wangyujun}@xiaomi.com

ABSTRACT

Recently, there has been an increasing interest in end-to-end speech recognition that directly transcribes speech to text without any predefined alignments. In this paper, we explore the use of attention-based encoder-decoder model for Mandarin speech recognition and to the best of our knowledge, achieve the first promising result. We reduce the source sequence length by skipping frames and regularize the weights for better generalization and convergence. Moreover, we investigate the impact of varying attention mechanism (convolutional attention and attention smoothing) and the correlation between the performance of the model and the width of beam search. On the MiTV dataset, we achieve a character error rate (CER) of 3.58% and a sentence error rate (SER) of 7.43% without using any lexicon or language model. While together with a trigram language model, we reach 2.81% CER and 5.77% SER.

Index Terms— automatic speech recognition, sequence-to-sequence model, attention-based speech recognition

1. INTRODUCTION

Deep Neural Networks (DNNs) have shown tremendous success and are widely used in speech recognition, usually in combination with Hidden Markov Models (HMMs) [1, 2, 3, 4, 5]. These systems are based on a complicated hybrid of separate components, including acoustic, phonetic and language models. Based on our knowledge, these components are trained separately, each with a different objective. Recently, some works on end-to-end neural network ASR systems such as Connectionist Temporal Classification (CTC) [6, 7, 8] and attention-based encoder-decoder [9, 10, 11, 12, 13, 14, 15, 16, 17] have emerged. All of these have shown promising results. The key idea of CTC is to allow repetitions of labels and occurrences of blank labels, but it still predicts labels for every frame. Another approach, the attention-based encoder-decoder, directly learns a mapping from the audio to the character sequence.

Attention-based encoder-decoder model has shown delightful results on complex sequence-to-sequence tasks, such

as machine translation [18, 19, 20], text summarization [21], image captioning [22], syntactic parsing [23], and speech recognition. Besides, it has now led to the state of the art in machine translation domain [20]. This model can map variable-length input sequences to variable-length output sequences. In attention-based encoder-decoder scheme, the encoder encodes an input sequence into a hidden representation and the decoder takes the representation and outputs a target sequence. The attention mechanism here is used to select or weight the input elements to generate the output elements. Training directly maximizes the probability of observing desired outputs conditioned on the inputs. Commonly, the model is trained using the character level cross-entropy criterion.

In this work, we investigate the application of attention-based encoder-decoder for Mandarin speech recognition. Considering that attention-based encoder-decoder performs very well in English speech recognition, many attempts have been proposed to optimize the model, such as a very deep convolutional network encoder [14] or varying attention mechanism [10]. [13] has explored the use of attention-based models for Mandarin and has found that the attention-based models are difficult to converge with Mandarin data. To solve this problem, we employ the L2 regularization and Gaussian weight noise for better generalization and convergence [24, 25]. In addition, the embedding of Chinese characters is adopted to be the input of the decoder, which has been proved to provide significant benefits to convergence in our experiments. [10] has shown that long utterances could have bad impacts on ASR. To address this problem, the frame sub-sampling idea [26, 27] is employed to reduce the length of utterances, and to speed up training and convergence. At the same time, we investigate a convolutional attention mechanism [10] and a smoothing method. In summary, we have made the following contributions: (1) achieving the first promising result for attention-based end-to-end speech recognition in Mandarin Chinese, (2) reducing input sequence length by skipping frames, (3) adopting various regularizations for better generalization and convergence and (4) investigating the impact of varying attention mechanism.

The rest of this paper is organized as follows. Section 2 introduces the details of attention-based model. We introduce our methods used in end-to-end attention based Mandarin ASR in Section 3. Section 4 describes the details of the experiments. Section 5 draws some conclusions and outlines our future work.

2. ATTENTION-BASED MODEL

In this section, we will describe the details of each component of the attention-based model.

2.1. Listen, Attend and Spell

Many challenging tasks need to process variable-length sequences. Examples are machine translation and speech recognition, where both input and output have variable lengths; and text summarization, where the summaries may have variable lengths. The Listen, Attend and Spell (LAS) [12] is an attention-based encoder-decoder network which is often used to deal with variable length input and output sequences. The encoder (the Listen module) extracts a variable-length representation from a variable-length input sentence. Then the attention mechanism (the Attend module) produces a fixed-length context vector and by using this representation, the decoder (the Spell module) generates a variable-length target translation.

In Fig.1 1, the encoder is a Bidirectional Long Short Term Memory RNN (BLSTM) that generates an output sequence $\mathbf{h} = (h_1, \dots, h_T)$ from an input \mathbf{x} . The decoder here is typically an LSTM that uses \mathbf{h} and $\mathbf{y}_{<i}$ to generate the output sequence $\mathbf{y} = (y_1, \dots, y_L)$. In this work, the output \mathbf{y} is a sequence of Chinese characters, and the input $\mathbf{x} = (x_1, \dots, x_T)$ is a sequence of feature vectors that is extracted from audio's frames:

$$\mathbf{h} = \text{Listen}(\mathbf{x}) \quad (1)$$

$$p(\mathbf{y}|\mathbf{x}) = \text{AttendAndSpell}(\mathbf{y}, \mathbf{h}). \quad (2)$$

In figure 2, the *AttendAndSpell* is an attention-based transducer, which generates one character y_i at a time:

$$s_i = \text{DecodeRNN}([y_{i-1}, c_{i-1}], s_{i-1}) \quad (3)$$

$$c_i = \text{AttentionContext}(s_i, \mathbf{h}) \quad (4)$$

$$p(y_i|\mathbf{x}, \mathbf{y}_{<i}) = \text{CharacterDistribution}(s_i, c_i) \quad (5)$$

The *DecodeRNN* produces a transducer state s_i as a function of the previously emitted token y_{i-1} , the previous attention context c_{i-1} , and the previous transducer state s_{i-1} . The *AttentionContext* function generates c_i with a context based Multi-Layer Perceptron (MLP) attention network. The *CharacterDistribution* is computed using a softmax function.

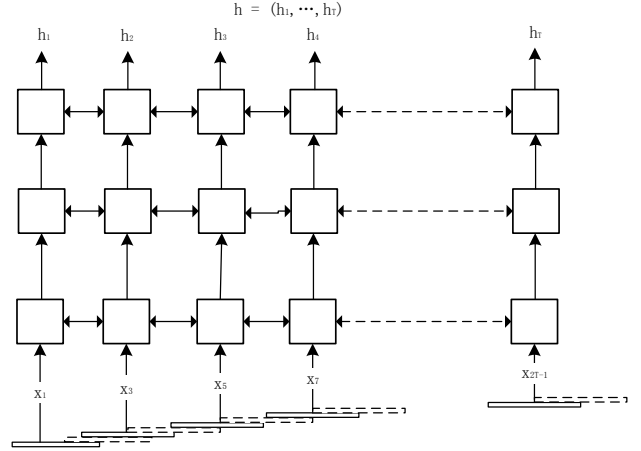

Fig. 1. The encoder model is a BLSTM that extracts \mathbf{h} from an input \mathbf{x} . The frame sub-sampling was employed during training.

2.2. Attention mechanism

The attention mechanism selects or weights the input frames to generate the next output element. A similar approach of attention has been used more recently in a so-called “neural machine translation model” [18]. In this case, for generating each target word, the network computes a score matching the hidden state of an output RNN to each location of the input sequence. The scores are normalized to sum to one over the input sequence and can be interpreted as a probability of each input location being aligned to the currently generated target word:

$$c_i = \text{AttentionContext}(s_i, \mathbf{h}) \quad (6)$$

$$c_i = \sum_{j=1}^T \alpha_{i,j} h_j \quad (7)$$

$$e_{i,j} = \text{Score}(s_{i-1}, h_j) \quad (8)$$

$$\alpha_{i,j} = \exp(e_{i,j}) / \sum_{j=1}^T \exp(e_{i,j}). \quad (9)$$

And the *Score* is an MLP network, which is described by the following equation:

$$e_{i,j} = \mathbf{w}^\top \tanh(\mathbf{W} s_{i-1} + \mathbf{V} h_j + \mathbf{b}). \quad (10)$$

This is the content-based attention proposed in [18].

3. METHODS

3.1. Convolutional attention

We suggest that the convolutional attention mechanism of the original model [18] should be location-aware by making

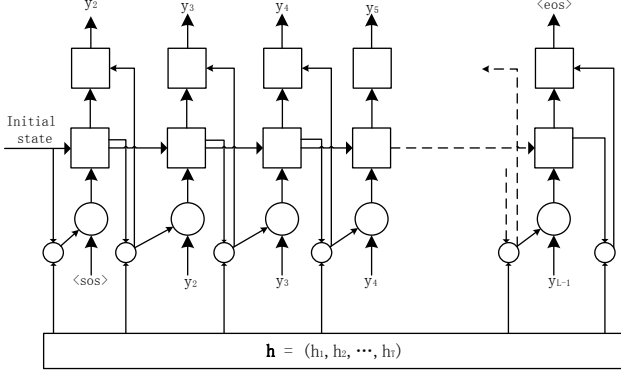

Fig. 2. The AttendAndSpell model composed by MLP (the Attention mechanism) and LSTM (the Decoder model). At each time step t , the context vector c_t is computed by an MLP that combines the hidden state s_{t-1} and the input \mathbf{h} . Then the new hidden state s_t and label y_t can be generated.

it take into account the alignment produced at the previous step [10]. This is achieved by the following equations:

$$\mathbf{f}_i = \mathbf{F} * \alpha_{i-1} \quad (11)$$

$$e_{i,j} = \mathbf{w}^\top \tanh(\mathbf{W}\mathbf{s}_{i-1} + \mathbf{V}\mathbf{h}_j + \mathbf{U}\mathbf{f}_{i,j} + \mathbf{b}). \quad (12)$$

3.2. Attention smoothing

When the input sequence \mathbf{h} is long, the α_i distribution is typically very sharp on convergence, and thus focused on only a few frames of \mathbf{h} . To keep the diversity of the model, we replace the softmax with the logistic sigmoid σ such that:

$$\alpha_{i,j} = \sigma(e_{i,j}). \quad (13)$$

The attention smoothing can smooth the focus found by the attention mechanism.

3.3. Skipping frames

The LAS model performance degrades quickly with longer utterances. This is presumably because the *AttendAndSpell* has a hard time extracting the relevant information from a large number of input time steps. [11, 12] solve this problem by pyramid BLSTM that reduces the time resolution by a factor of 2 in each BLSTM layer. In this paper, the frame sub-sampling idea [26, 27] is employed for fast training and convergence. During decoding, we use all frames to generate the context \mathbf{h} .

3.4. Regularization

In many tasks, the model would overfit the data and give poor generalization to new data. To avoid overfitting we need to decrease the information in the weights [24, 25]. Two main

regularizations are used in this paper: L2 regularization and Gaussian weight noise.

The idea of L2 regularization is to add an extra term to the cost function. The Gaussian weight noise is added to all the weights. Additive noise achieves better generalization and yields slightly better convergence. It tends to simplify the neural networks, in the sense of reducing the amount of information in the parameters.

3.5. Language model

At each timestep, the decoder generates an character depending on the previous ones. However, it's insufficient to learn a complex language model [11], so we build a character-level language model from a word-level language model G and a lexicon L that simply spells out the character of each word. More specifically, we build an Finite State Transducer (FST) $T = \min(\det(L \circ G))$ to calculate the log-probability for character sequences. We add the weighted T to the loss of encoder's output during decoding:

$$C = - \sum_i [\log P_{AM}(y_i|x, y_{<i}) + \gamma \log P_{LM}(y_i|y_{<i})] \quad (14)$$

During decoding, we will minimize the loss C which combines the attention-based model (AM) and the language mode (LM) with a tunable parameter γ .

3.6. Optimization

We optimize the parameters of our model to maximize the log-likelihood of observing correct Chinese characters sequences conditioned on utterances:

$$\max_{\theta} \log P(\mathbf{y}|\mathbf{x}) = \max_{\theta} \prod_i P(y_i|\mathbf{x}, \mathbf{y}_{1:i-1}). \quad (15)$$

Traditionally, the model was trained using the character level cross-entropy criterion. Based on this, the loss function is defined as follows:

$$C \triangleq - \sum_i \sum_k^K [P(\tilde{y}_{i,k}) \log P(y_{i,k}) + (1 - P(\tilde{y}_{i,k})) \log(1 - P(y_{i,k}))] \quad (16)$$

where $\tilde{y}_{i,k}$ is the ground truth of the k -th character's label at time i .

3.7. Decoding

A simple left-to-right beam search algorithm performs well during decoding. We start with the start-of-sentence $\langle \text{sos} \rangle$ token, keeping a n -best list of candidate hypothesizes. At each timestep, each hypothesis in the beam is expanded with every possible character and only the n most likely beams are kept. Beam search is stopped when the end-of-sequence $\langle \text{eos} \rangle$ token is emitted. We find that a wider beam width can only give fewer benefits.

Table 1. Results of our Attention-based model with a beam size of 30, $\tau = 2$ and $\gamma = 0.1$.

model	CER/%	SER/%
Content based attention	4.05	9.10
+ trigram LM	3.60	7.20
Attention Smoothing	3.58	7.43
+ trigram LM	2.81	5.77
Convolutional attention	3.82	8.17
+ trigram LM	3.26	6.33

4. EXPERIMENTS

4.1. Data

We used a data set containing approximately four million MiTV voice search utterances (about 3,000 hours) in our experiments. The test data and held-out validation set were randomly selected and each had 3,000 utterances. As input features, we used 80 Mel scale filterbank coefficients computed every 10ms with delta and delta-delta acceleration and did the mean and variance normalization per speaker. For the Decoder model, we used 6,925 labels: 6,922 common Chinese characters, unknown token and $\langle \text{sos} \rangle / \langle \text{eos} \rangle$ tokens.

4.2. Training

We constructed a common ASR attention-based model. The model Encoder function was a 3 layer BLSTM with 256 LSTM units per-direction (or 512 in total). The Decoder was a 1 layer LSTM with 256 LSTM units. All the weight matrices were initialized with the normalized initialization [28] and the bias vectors were initialized to 0. Gradient norm clipping to 1 was applied, together with Gaussian weight noise and L2 weight decay $1e-5$. We used ADAM with the default hyperparameters described in [29], however we decayed the learning rate from $1e-3$ to $1e-4$ after it converged. The model cost combines the softmax output and the cross entropy cost.

4.3. Results

Table 1 shows that our model performed very well in Mandarin ASR. The content-based attention model achieves a CER of 4.05% and a SER of 9.1%. By using the attention smoothing model, we improved our CER to 3.58% or obtained a 11.6% relative gain over the content-based attention. We have observed that attention-based models often yield very sharp predictions. The sigmoid function keeps the diversity of model and smooths the focus found by the attention mechanism. The convolutional attention model also has a good performance and achieves a CER of 3.82% and a SER of 8.17%.

Furthermore, we analyzed the importance of the beam-search width on decoding accuracy [10]. Figure 3 shows the effect of the decode beam width on the WER/SER for the test

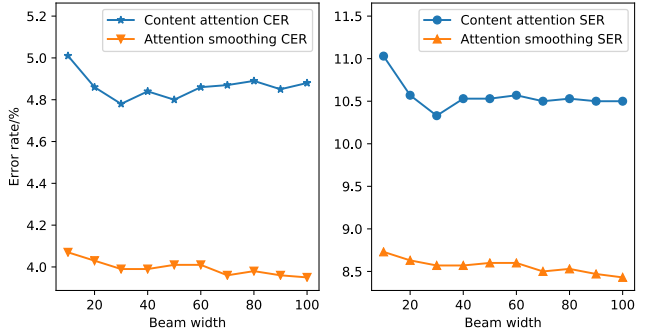

Fig. 3. The effect of the decoding beam width on CER/SER for the content-based attention and the attention smoothing models with $\tau = 1$. The figure shows that the accuracy degrades very slightly if the beam search is replaced with a greedy search.

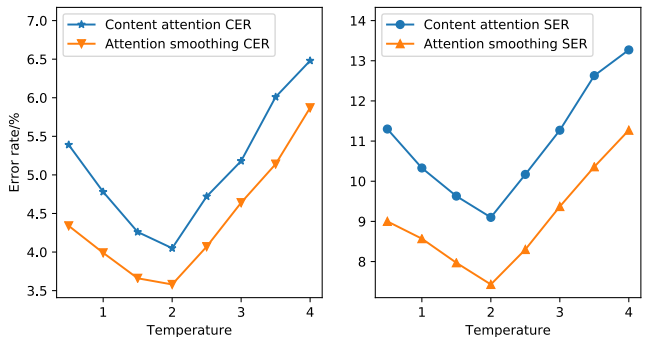

Fig. 4. The impact of the temperature of the softmax on CER/SER for content-based attention and attention smoothing models with a beam size of 30. The $\tau = 2$ achieves the best performance.

set. At a beam width of 30, the CER is 4.78%, after which we observe no significant benefits. The attention smoothing model has achieved similar results. We observed that a narrow beam width was required to reach optimal performance (beam size 30 was sufficient) and that allowed faster decoding. We also investigated the impact of the temperature of the softmax function [13]. The temperature can smooth the distribution of character. We changed the character probability distribution by a temperature hyperparameter τ :

$$\alpha_{i,j} = \exp(e_{i,j}/\tau) / \sum_j \exp(e_{i,j}/\tau). \quad (17)$$

In Fig. 4, the $\tau = 2$ shows the best performance. There is no additional benefits when we continue increasing the temperature.

Meanwhile, we investigated the effect of language model. During decoding, we used the extended trigram language model and achieved a better result. And attention smoothing showed the best performance with $\gamma = 0.1$.

5. CONCLUSION

We have achieved the first promising result for end-to-end Chinese speech recognition based on the attention encoder-decoder. Our model achieves a CER of 3.58% and a SER of 7.43% on a voice search task. We employ the sub-sampling idea for fast training and convergence. Meanwhile, the L2 regularization and Gaussian weight noise are used for better generalization and convergence. We also investigate the issues with the normalization of the content attention and the convolutional attention.

Our work has shown that the attention-based encoder-decoder model has a good performance in Mandarin ASR. By combining our model with existing techniques such as the very deep convolutional networks, further improvements should be achievable. This will be our future work.

6. ACKNOWLEDGMENTS

The authors would like to acknowledge the developers of TensorFlow [30] and all experiments were implemented using the TensorFlow framework. We also thank Yu Zhang and Jian Li for helpful comments, suggestions and technical assistance and the Xiaomi Deep Learning Team and MiAI SRE Team for Xiaomi Cloud-ML and GPU cluster support.

7. REFERENCES

- [1] Nelson Morgan and Herve Bourlard, “Continuous speech recognition using multilayer perceptrons with hidden markov models,” in *Acoustics, Speech, and Signal Processing, 1990. ICASSP-90., 1990 International Conference on*. IEEE, 1990, pp. 413–416.
- [2] Geoffrey Hinton, Li Deng, Dong Yu, George E Dahl, Abdel-rahman Mohamed, Navdeep Jaitly, Andrew Senior, Vincent Vanhoucke, Patrick Nguyen, Tara N Sainath, et al., “Deep neural networks for acoustic modeling in speech recognition: The shared views of four research groups,” *IEEE Signal Processing Magazine*, vol. 29, no. 6, pp. 82–97, 2012.
- [3] Li Deng, Jinyu Li, Jui-Ting Huang, Kaisheng Yao, Dong Yu, Frank Seide, Michael Seltzer, Geoff Zweig, Xiaodong He, Jason Williams, et al., “Recent advances in deep learning for speech research at microsoft,” in *Acoustics, Speech and Signal Processing (ICASSP), 2013 IEEE International Conference on*. IEEE, 2013, pp. 8604–8608.
- [4] Jürgen Schmidhuber, “Deep learning in neural networks: An overview,” *Neural networks*, vol. 61, pp. 85–117, 2015.
- [5] Wayne Xiong, Jasha Droppo, Xuedong Huang, Frank Seide, Mike Seltzer, Andreas Stolcke, Dong Yu, and Geoffrey Zweig, “The microsoft 2016 conversational speech recognition system,” in *Acoustics, Speech and Signal Processing (ICASSP), 2017 IEEE International Conference on*. IEEE, 2017, pp. 5255–5259.
- [6] Alex Graves, Santiago Fernández, Faustino Gomez, and Jürgen Schmidhuber, “Connectionist temporal classification: labelling unsegmented sequence data with recurrent neural networks,” in *Proceedings of the 23rd international conference on Machine learning*. ACM, 2006, pp. 369–376.
- [7] Dario Amodei, Sundaram Ananthanarayanan, Rishita Anubhai, Jingliang Bai, Eric Battenberg, Carl Case, Jared Casper, Bryan Catanzaro, Qiang Cheng, Guoliang Chen, et al., “Deep speech 2: End-to-end speech recognition in english and mandarin,” in *International Conference on Machine Learning*, 2016, pp. 173–182.
- [8] Yajie Miao, Mohammad Gowayed, and Florian Metze, “Eesen: End-to-end speech recognition using deep rnn models and wfst-based decoding,” in *Automatic Speech Recognition and Understanding (ASRU), 2015 IEEE Workshop on*. IEEE, 2015, pp. 167–174.
- [9] Jan Chorowski, Dzmitry Bahdanau, Kyunghyun Cho, and Yoshua Bengio, “End-to-end continuous speech recognition using attention-based recurrent nn: first results,” *arXiv preprint arXiv:1412.1602*, 2014.
- [10] Jan K Chorowski, Dzmitry Bahdanau, Dmitriy Serdyuk, Kyunghyun Cho, and Yoshua Bengio, “Attention-based models for speech recognition,” in *Advances in Neural Information Processing Systems*, 2015, pp. 577–585.
- [11] Dzmitry Bahdanau, Jan Chorowski, Dmitriy Serdyuk, Philemon Brakel, and Yoshua Bengio, “End-to-end attention-based large vocabulary speech recognition,” in *Acoustics, Speech and Signal Processing (ICASSP), 2016 IEEE International Conference on*. IEEE, 2016, pp. 4945–4949.
- [12] William Chan, Navdeep Jaitly, Quoc Le, and Oriol Vinyals, “Listen, attend and spell: A neural network for large vocabulary conversational speech recognition,” in *Acoustics, Speech and Signal Processing (ICASSP), 2016 IEEE International Conference on*. IEEE, 2016, pp. 4960–4964.
- [13] William Chan and Ian Lane, “On online attention-based speech recognition and joint mandarin character-pinyin training,” in *INTERSPEECH*, 2016, pp. 3404–3408.
- [14] Yu Zhang, William Chan, and Navdeep Jaitly, “Very deep convolutional networks for end-to-end speech recognition,” in *Acoustics, Speech and Signal Processing (ICASSP), 2017 IEEE International Conference on*. IEEE, 2017, pp. 4845–4849.

- [15] Suyoun Kim, Takaaki Hori, and Shinji Watanabe, “Joint ctc-attention based end-to-end speech recognition using multi-task learning,” in *Acoustics, Speech and Signal Processing (ICASSP), 2017 IEEE International Conference on*. IEEE, 2017, pp. 4835–4839.
- [16] Tsubasa Ochiai, Shinji Watanabe, Takaaki Hori, and John R Hershey, “Multichannel end-to-end speech recognition,” *arXiv preprint arXiv:1703.04783*, 2017.
- [17] Jan Chorowski and Navdeep Jaitly, “Towards better decoding and language model integration in sequence to sequence models,” *arXiv preprint arXiv:1612.02695*, 2016.
- [18] Dzmitry Bahdanau, Kyunghyun Cho, and Yoshua Bengio, “Neural machine translation by jointly learning to align and translate,” *arXiv preprint arXiv:1409.0473*, 2014.
- [19] Kyunghyun Cho, Bart Van Merriënboer, Caglar Gulcehre, Dzmitry Bahdanau, Fethi Bougares, Holger Schwenk, and Yoshua Bengio, “Learning phrase representations using rnn encoder-decoder for statistical machine translation,” *arXiv preprint arXiv:1406.1078*, 2014.
- [20] Yonghui Wu, Mike Schuster, Zhifeng Chen, Quoc V Le, Mohammad Norouzi, Wolfgang Macherey, Maxim Krikun, Yuan Cao, Qin Gao, Klaus Macherey, et al., “Google’s neural machine translation system: Bridging the gap between human and machine translation,” *arXiv preprint arXiv:1609.08144*, 2016.
- [21] Alexander M Rush, Sumit Chopra, and Jason Weston, “A neural attention model for abstractive sentence summarization,” *arXiv preprint arXiv:1509.00685*, 2015.
- [22] Kelvin Xu, Jimmy Ba, Ryan Kiros, Kyunghyun Cho, Aaron Courville, Ruslan Salakhudinov, Rich Zemel, and Yoshua Bengio, “Show, attend and tell: Neural image caption generation with visual attention,” in *International Conference on Machine Learning*, 2015, pp. 2048–2057.
- [23] Oriol Vinyals, Łukasz Kaiser, Terry Koo, Slav Petrov, Ilya Sutskever, and Geoffrey Hinton, “Grammar as a foreign language,” in *Advances in Neural Information Processing Systems*, 2015, pp. 2773–2781.
- [24] Geoffrey E Hinton and Drew Van Camp, “Keeping the neural networks simple by minimizing the description length of the weights,” in *Proceedings of the sixth annual conference on Computational learning theory*. ACM, 1993, pp. 5–13.
- [25] Kam-Chuen Jim, C Lee Giles, and Bill G Horne, “An analysis of noise in recurrent neural networks: convergence and generalization,” *IEEE Transactions on neural networks*, vol. 7, no. 6, pp. 1424–1438, 1996.
- [26] Haşim Sak, Andrew Senior, Kanishka Rao, and Françoise Beaufays, “Fast and accurate recurrent neural network acoustic models for speech recognition,” *arXiv preprint arXiv:1507.06947*, 2015.
- [27] Yajie Miao, Jinyu Li, Yongqiang Wang, Shi-Xiong Zhang, and Yifan Gong, “Simplifying long short-term memory acoustic models for fast training and decoding,” in *Acoustics, Speech and Signal Processing (ICASSP), 2016 IEEE International Conference on*. IEEE, 2016, pp. 2284–2288.
- [28] Xavier Glorot and Yoshua Bengio, “Understanding the difficulty of training deep feedforward neural networks,” in *Proceedings of the Thirteenth International Conference on Artificial Intelligence and Statistics*, 2010, pp. 249–256.
- [29] Diederik Kingma and Jimmy Ba, “Adam: A method for stochastic optimization,” *arXiv preprint arXiv:1412.6980*, 2014.
- [30] Martín Abadi, Ashish Agarwal, Paul Barham, Eugene Brevdo, Zhifeng Chen, Craig Citro, Greg S Corrado, Andy Davis, Jeffrey Dean, Matthieu Devin, et al., “Tensorflow: Large-scale machine learning on heterogeneous distributed systems,” *arXiv preprint arXiv:1603.04467*, 2016.