

Teechain: A Secure Asynchronous Blockchain Payment Network

Joshua Lind*, Oded Naor,[¶] Ittay Eyal,[¶] Florian Kelbert*, Peter Pietzuch*, Emin Gun Sirer[†]

^{*}Imperial College London

[†]Cornell University and IC3

[¶]Technion – Israel Institute of Technology

Abstract

Blockchain protocols exchange payment transactions securely, but their performance is limited by the need to achieve global consensus. Payment networks, as a second layer on top of blockchains, allow more efficient payments between parties. Existing payment networks, however, are fundamentally insecure: they assume *synchronous blockchain access*, i.e. that participants can write transactions to the blockchain within bounded time. As shown recently, attackers can delay transactions with current blockchains, which only offer best-effort write latencies, and thus steal funds.

We describe *Teechain*, the first layer-two payment network that only requires *asynchronous blockchain access*. Teechain exploits trusted execution environments (TEEs) in modern CPUs: Teechain constructs a decentralised network of TEEs and uses TEEs to secure collateral funds in payment channels without further interaction with the blockchain. Since TEEs provide no availability guarantees and may be compromised themselves, Teechain mitigates against Byzantine TEE failures through a novel combination of chain replication and threshold secret sharing. Teechain achieves at least 33× higher transaction throughput than the Lightning Network with similar latencies, while placing 75% fewer transactions on the blockchain in the common case. A Teechain deployment with 30 machines can handle over 1 million Bitcoin transactions per second.

1 Introduction

Cryptocurrencies [46, 70, 51, 53] enable secure transactions between participants using *blockchain protocols*. Current blockchain protocols have limited performance due to their need to achieve consensus for all transactions. For example, global throughput in Bitcoin [46] and Ethereum [70] is capped at a handful of transactions per second, and transactions take minutes or hours to be committed. *Payment networks* [21, 15, 50] have been proposed as a more performant second layer on top of the blockchain. They execute transactions *off-chain*,

without writing to the underlying blockchain for every transaction, thus enabling much higher transaction throughput.

Existing payment network protocols [15, 50, 9], however, are fundamentally insecure: they assume *synchronous blockchain access* under which participants must be able to write transactions to the blockchain within a bounded period of time τ . This makes these protocols vulnerable to attack: blockchains do not guarantee bounded write latencies, and transaction can be delayed by attackers, as demonstrated by recent attacks [54, 58, 27, 7, 29, 16, 28]. Existing payment network protocols therefore trade-off safety and liveness: funds are locked in escrow on the underlying blockchain during τ . If τ is small to reduce fund lock times, an attacker can more easily delay transactions to steal funds; if τ is large to make attacks more expensive, funds are inaccessible and unusable for longer periods of time.

We present *Teechain*, a new payment network that supports secure fund transfers on top of existing blockchains while requiring only *asynchronous blockchain access*. In contrast to existing proposals, Teechain makes no assumptions about bounded transaction write times to the blockchain, thus avoiding the trade-off between fund safety and liveness.

To achieve asynchronous blockchain access, Teechain exploits the support for *trusted execution environments* (TEEs) in commodity CPUs [23, 4]. TEEs are a hardware security feature that protects the confidentiality and integrity of code and data. Teechain uses TEEs to manage the funds in the payment network: it constructs a peer-to-peer decentralized network of TEEs, and assigns funds and balances across payment channels. As existing TEE implementations are vulnerable to compromise [67, 8, 45], Teechain assumes a Byzantine failure model for TEEs. It uses a chain replication scheme combined with threshold secret sharing to be resilient against individual TEE compromises.

The design of Teechain makes three contributions:

(C1) Asynchronous blockchain access. Teechain is the first payment network to operate with asynchronous blockchain access. It comprises two protocols: (i) a protocol for point-to-point *payment channels* in which two participants can ex-

change funds; and (ii) a protocol for *multi-hop payments* that offers payments along paths of payment channels. As TEEs manage fund balances, Teechain achieves high transaction throughput and low latency by executing transactions as single message exchanges—unlike existing solutions.

(C2) Dynamic deposit assignment. Teechain decouples the creation of fund deposits from payment channel establishment. As deposits are secured by TEEs, participants can create deposits in advance, dynamically assign them to channels upon establishment, and move them in and out of channels at run-time. Since deposit assignment does not require blockchain access, payment channels are established within seconds.

(C3) Chain replication and threshold signatures. To replicate the in-memory TEE state, Teechain uses *force-freeze chain replication*, a new variant of chain replication that achieves high availability and strong consistency, while preventing roll-back and forking attacks. To account for TEE compromises [67], Teechain assumes a Byzantine failure model for TEEs. After partitioning the state across multiple TEEs, it tolerates Byzantine failures by exploiting multisignature support of the underlying blockchain. To access funds, a sufficient number of TEE signatures are required.

We implement Teechain using Intel’s SGX TEEs [22] and deploy it on the Bitcoin network.¹ In addition to supporting asynchronous blockchain access, Teechain performs significantly better than existing solutions: channel establishment takes seconds, as opposed to minutes or hours with previous solutions [15, 50]. Compared to the Lightning Network [37], Teechain with two replicas achieves at least 33× higher transaction throughput with similar latencies, while placing fewer transactions on the underlying blockchain.

2 Secure Payment Networks for Blockchains

2.1 Blockchain protocols

In comparison to earlier payment systems [48, 69, 2], blockchain protocols, such as Bitcoin [46] and Ethereum [63], are not operated by a central trusted entity; instead they execute a peer-to-peer replicated state machine that maintains an append-only *ledger* containing the history of all payment transactions in the network.

As blockchain protocols must achieve consensus over the order of all transactions in the ledger, their throughput is limited. Past work tries to address their performance limitations, from alternatives to the chain structure [36, 63, 56] to different block generation techniques [17, 33, 47]; others [42, 44, 18, 59] build on classical consensus protocols [13] or operate in permissioned settings [10, 20]. While all these proposals improve performance, none can reach the performance of direct payments that do not require global consensus.

¹An alpha release of Teechain can be found at: *redacted for anonymity*

2.2 Payment channels and networks

Payment channels [38, 43, 49, 15, 50] overcome the performance limitations of blockchains by allowing parties to exchange funds directly, *off-chain*, without having to use the blockchain for each transaction. Instead, transactions become message exchanges in which parties update the balances, or *state*, of the payment channel directly. *Payment networks* [50, 65, 40] chain multiple channels together to create multi-hop payment paths between parties that do not have a direct payment channel. This is necessary to support e-commerce scenarios in which buyers and sellers conduct transactions via intermediaries [1]. To prevent fund loss or theft, all channels in the path must update their balances in unison. Payment networks solve this by freezing funds during payment routing and monitoring the blockchain, which prevents other users from terminating channels freely [50].

Existing payment networks, however, assume synchronous blockchain access—users must be able to write transactions to the blockchain within a bounded period of time, τ . This is to prevent old and stale channel states from being published on the blockchain to steal funds. For example, in Duplex Micropayment Channels [15], time-locked transactions prevent older channel states from published before newer ones; in the Lightning Network [50], users monitor the blockchain for old states, and if found, have a bounded amount of time to react.

Blockchain protocols, however, fail to bound write latencies: transactions can be delayed with little cost, as shown by recent attacks [58, 27, 29, 16, 28, 54], making existing payment networks vulnerable to attack. When payment channels lock channel funds in escrow on the underlying blockchain [38, 15, 50, 43] during the synchronous time period, τ , there is a trade-off between security and liveness: if τ is small to reduce lock times, an attacker can more easily delay transactions to steal funds; if τ is large to make attacks more expensive, funds are inaccessible for larger periods of time.

Existing payment networks also suffer from long channel establishment times, and lack the ability to add and remove funds from payment channels dynamically [38, 50, 15]. While it is possible to redistribute funds between static groups of payment channels [9], this limits fund redistribution to a fixed group of collaborating participants. REVIVE [32] rebalances payment channels by sending payments along cycles in a payment network but relies on synchronous blockchain access and locks funds statically to channels; Sprites [43] can add and remove funds to and from channels dynamically, but requires on-chain support for complex transaction constructs, which is incompatible with blockchains such as Bitcoin.

2.3 Trusted hardware and blockchains

Trusted execution environments (TEEs) [23, 4, 30, 31] have been used to improve the security and performance of blockchain protocols. TEEs provide confidentiality and integrity

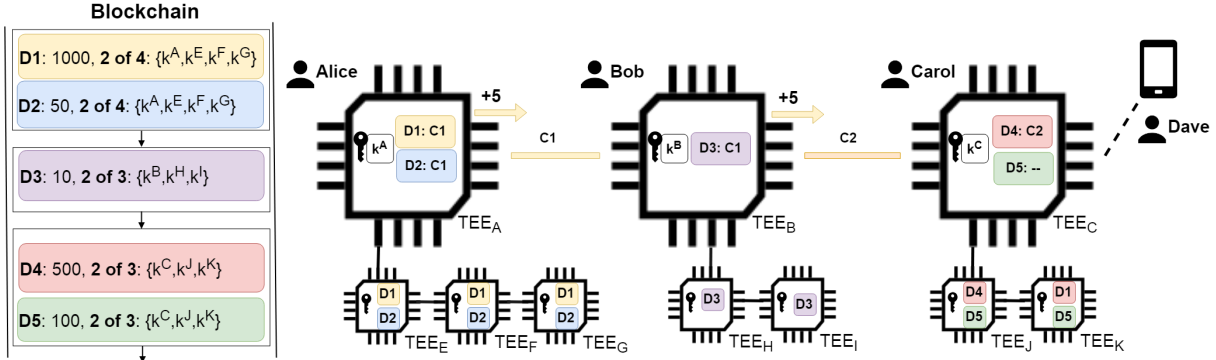

Figure 1: Overview of the Teechain network

guarantees to code and data in a system, as long as the physical CPU is not breached. TEEs typically also support remote attestation [26, 24], which allows remote parties to verify that a certain piece of software is running within a genuine TEE. Existing TEE implementations are vulnerable to side-channel attacks [8, 45], and thus TEE compromises are possible [67].

Tesseract [6] constructs a secure cryptocurrency exchange but is incompatible with payment networks. Other work focuses on the use of TEEs for smart contracts: TownCrier enables a secure data-feed for blockchain contracts [72], Ekiden [14] offers a platform for privacy preserving smart contracts; Obscuro constructs a secure Bitcoin mixer using TEEs [66]; TEEChan [38] uses TEEs to realize single-hop payment channels with limited lifetimes. It provides limited fault tolerance, requires synchronous blockchain access, does not support multi-hop payments, and cannot create payment channels instantly or dynamically assign deposits.

2.4 Threat model and problem statement

We assume a scenario in which mutually distrusting parties use a blockchain-based cryptocurrency to exchange funds. Parties are selfish and potentially malicious, i.e. if it benefits them, they may attempt to steal funds and deviate from the protocol. Parties may drop, send, record, modify, and replay messages. Parties may also collude with one another. The parties are connected via a network, with some parties behind firewalls or network address translation (NAT).

Our goal is to design an off-chain payment network that achieves high transaction throughput for secure multi-hop payments, while assuming asynchronous access to the underlying blockchain and Byzantine failures of all participants.

3 Teechain Overview

We provide an overview of Teechain. Teechain constructs a peer-to-peer payment network using TEEs. Funds in Teechain are controlled and managed by the TEEs and distributed

across payment channels. As shown in Fig. 1, participants, such as *Alice* and *Bob*, operate *local TEEs* (TEE_A and TEE_B) that execute the Teechain protocols. Users without a local TEE, such as *Dave*, can use a *remote TEE* to manage funds.

Payment channels and multi-hop payments. Teechain forms bidirectional *payment channels* between TEEs with direct network connectivity. This enables two participants to exchange funds (e.g. Fig. 1, channel *C1* between *Alice* and *Bob*). Teechain operates with asynchronous blockchain access: whenever a channel is terminated, only a single blockchain transaction for the final state of the channel is generated, avoiding the need to invalidate old transactions on the blockchain. We describe the payment channel protocol in §4.

Teechain also supports *multi-hop payments* by chaining multiple payment channels together, forming an indirect path for the exchange of funds. Fig. 1 shows a multi-hop payment with *Alice* paying *Carol* via *Bob* using path *C1–C2*. Multi-hop payments are composed of at least two payment channels, and ensure all channels in the path update together.² We describe the multi-hop payment protocol in §5.

Deposit creation and association. Funds can be added and removed from Teechain dynamically by creating and releasing fund *deposits*. Deposits are controlled by the TEEs in the network and created through transactions that spend into cryptocurrency addresses where the private keys for those addresses are secured by TEEs (e.g. TEE_A contains two deposits, *D1* and *D2*, and secures the private key k_A). Each deposit is placed on the blockchain and pays into an *m-out-of-n* multisignature address: these are cryptocurrency addresses owned by *n* participants that require only *m* signatures to spend from [62]. *D1*, for example, pays 1000 units of cryptocurrency into a 2-out-of-4 multisignature address where the 4 cryptocurrency addresses are owned by the private keys of TEE_A , TEE_E , TEE_F and TEE_G , and 2 signatures from those 4 TEEs are required to spend *D1*.

Deposit creation is decoupled from payment channel in-

²Finding routes within the Teechain network is outside the scope of this paper. We assume participants determine paths out-of-band.

stantiation. Participants can associate deposits with channels dynamically to increase their balances. Since deposit association does not require blockchain access, payment channels can be established with low latency (see §7). Fig. 1 shows channel $C1$ containing deposits $D1$ and $D2$ from *Alice*, and deposit $D3$ from *Bob*. Some deposits may be unassociated with any channel (e.g. $D5$) and can be released from the network upon request. §4 describes deposit creation and association.

Committee chains. As TEEs in Teechain control funds in volatile memory, crash failures can lead to fund loss, and TEE compromises [67] can lead to fund theft. To overcome crash and Byzantine failures, Teechain constructs *committee chains* that secure deposits and replicate deposit state in the network. Committee chains consist of replication chains of TEEs where the committee members control the private keys for a deposit (e.g. TEE_A has a committee chain with 3 other TEEs that replicate deposit states $D1$ and $D2$). Teechain uses monetary incentives to motivate committee participation. For each payment, committee members takes a small, configurable fee. This enables Teechain to tolerate threshold TEE compromises. We describe committee chains in §6.

TEE outsourcing. Users without a local TEE (e.g. *Dave*, Fig. 1), may participate in Teechain through *TEE outsourcing*: using a remote TEE in the network as a local TEE. For this, the user attests a remote TEE and provisions it with a shared secret key, giving them the same abilities as a local TEE user. To prevent having to trust remote TEE operators, Teechain (i) constructs committee chains using other TEEs; and (ii) uses monetary incentives to motivate availability.

4 Teechain payment channels

Teechain forms bidirectional payment channels using TEEs to allow participants to exchange funds directly. Teechain delegates fund ownership to the TEEs in the network through fund deposits. Participants instruct their TEEs to establish payment channels, associate funds with channels, execute payments, and terminate channels by generating settlement transactions for the blockchain.

Due to memory limitations of existing TEEs [22], Teechain does not maintain the complete blockchain in the TEE. As such, TEEs have no direct way of verifying transactions. Participants must therefore interact with the blockchain in four cases: (i) when funds are deposited into the network; (ii) when funds are released from the network; (iii) when a new deposit is approved and assigned to a channel; and (iv) when payment channels are terminated. In each case, interaction occurs without assuming bounded blockchain latencies.

4.1 Payment channel protocol

We present the Teechain payment channel protocol in Alg. 1. **Immediate payment channel creation.** Teechain allows

payment channels to be created without blockchain interaction. To construct a payment channel, first, a secure network channel is established between two TEEs (`newNetworkChannel`, Alg. 1, line 15) using authenticated Diffie-Hellman [34] to provision keys (line 17); remote attestation ensures TEE validity. Authentication occurs through a unique public/private key pair generated securely by each TEE (line 1)—keys are exchanged out-of-band. Authentication in this manner prevents messages from being shared between multiple TEEs, avoiding state-forking attacks in which attackers maintain multiple different TEE states by forking and withholding messages.

Using the secure network channel, payment channels can be created. Both participants provide their TEEs with the remote public key and a cryptocurrency settlement address, i.e. an address to be paid upon channel settlement and deposit return (`newPayChannel`, line 18). The TEEs then associate this information with the channel and create a signed acknowledgement message (line 26), opening the channel (line 27).

Dynamic deposit assignment. Teechain allows funds to be associated/dissociated with payment channels at runtime. A deposit is a transaction, txo , placed on the blockchain that spends funds into an m -out-of- n address, where the n addresses are TEE-owned address returned by command `newAddr` (line 32). For simplicity, Alg. 1 constrains deposits to be paid into 1-out-of-1 multisignature addresses. We outline the protocol for general m -out-of- n deposits in §6.1.

New deposits can be added at any time (`newDeposit`, line 36). The corresponding private keys to spend deposits are stored in the TEEs (line 34), allowing the funds to be released later (`releaseDeposit`, line 42). Before a deposit can be associated with a channel, the remote party must approve it (`approveMyDeposit`, line 48). Deposit approval allows participants to define the security parameters of their channels, i.e. how many transaction confirmations they require. Participants can validate other deposits in the network (line 58) and notify TEEs of deposit approval (line 59). Deposits only need to be approved once for each participant pair, and can be created and approved in advance of payment channel creation.

Unassociated deposits can be associated with a payment channel (`associateMyDeposit`, line 64). Channel balances are updated (line 70 and line 79) and the corresponding private key is shared with the remote TEE (line 73), enabling the remote to spend the deposit upon channel termination (line 72). Deposit dissociation works similarly (`dissociateDeposit`, line 90). To prevent double-spending, dissociation requires the remote TEE to acknowledge the request first (line 99) and to destroy its copy of the private key (line 104).

Payment deposit rebalancing. If balances permit, participants can execute payments. Command `pay` (line 82) updates channel balances locally and notifies the remote (line 86) to update its balance (line 87). Teechain allows deposit rebalancing to reduce collateral fund lock-in. For example, assuming a channel c with deposit d_1 of value v_1 , after payments of

Algorithm 1: Teechain payment channel protocol (For brevity, we constrain deposits to be paid into 1-out-of-1 multisignature addresses; §6.1 outlines the protocol for general m -out-of- n deposits. We omit freshness protection of messages.)

```

1   $(K_{me}, k_{me}) \leftarrow$  generate public, private keys
2   $\forall K : net_{aes}(K) = \perp$  /* AES keys for network channels */
3   $\forall id : c_{remote\_K}(id) = \perp$  /* Remote pub keys */
4   $\forall id : c_{is\_open}(id) = False$  /* Pay chans closed */
5   $\forall id : c_{my\_deps}(id) = \perp$  /* My deposits in pay chan */
6   $\forall id : c_{remote\_deps}(id) = \perp$  /* Remote deps in pay chan */
7   $\forall id : c_{my\_bal}(id) = \perp$  /* My bal in pay chan */
8   $\forall id : c_{remote\_bal}(id) = \perp$  /* Remote bal in pay chan */
9   $\forall id : c_{my\_add}(id) = \perp$  /* My Bitcoin addresses */
10  $\forall id : c_{remote\_add}(id) = \perp$  /* Remote Bitcoin addresses */
11  $\forall tx : allDeps(tx) = \perp$  /* All tx output deposits */
12  $\forall tx : freeDeps(tx) = \perp$  /* Unassociated deposits */
13  $\forall K : appDeps(K) = \perp$  /* Remote approved deps */
14  $\forall a_{btc} : btcPrivs(a_{btc}) = \perp$  /* Btc private keys */
15 on newNetworkChannel( $K_{remote}$ )
16   assert  $net_{aes}(K_{remote}) = \perp$ 
17    $net_{aes}(K_{remote}) \leftarrow$  remote attestation and
    authenticated Diffie-Hellman using  $K_{remote}$ 
18 on newPayChannel( $id, K_{remote}, a_{btc}^{remote}, a_{btc}^{me}$ )
19   assert  $c_{remote\_K}(id) = \perp$ 
20    $c_{remote\_K}(id) \leftarrow K_{remote}$ 
21    $c_{my\_add}(id) \leftarrow a_{btc}^{me}$ 
22    $c_{remote\_add}(id) \leftarrow a_{btc}^{remote}$ 
23    $c_{my\_bal}(id) \leftarrow 0$ 
24    $c_{remote\_bal}(id) \leftarrow 0$ 
25    $c_{is\_open}(id) \leftarrow False$ 
26   return ( $newChannelAck, id, a_{btc}^{me}, a_{btc}^{remote}$ ) signed by
     $k_{me}$ 
27 on receive ( $newChannelAck, id, a_{btc}^{remote}, a_{btc}^{me}$ ) signed by
     $k$  for  $c_{remote\_K}(id)$ 
28   assert  $c_{is\_open}(id) = False$ 
29   assert  $c_{my\_add}(id) = a_{btc}^{me}$ 
30   assert  $c_{remote\_add}(id) = a_{btc}^{remote}$ 
31    $c_{is\_open}(id) \leftarrow True$ 
32 on newAddr()
33    $(a_{btc}, k_{btc}) \leftarrow$  new Bitcoin address and private key
34    $btcPrivs(a_{btc}) \leftarrow k_{btc}$ 
35   return  $a_{btc}$ 
36 on newDeposit( $txo, a_{btc}$ )
37   assert  $btcPrivs(a_{btc})$  exists
38   assert  $txo \notin allDeps$  /* can't add same dep twice */
39   assert  $txo.btcAddress = a_{btc}$  /* verify txo */
40    $allDeps \leftarrow allDeps \cup \{txo\}$ 
41    $freeDeps \leftarrow freeDeps \cup \{txo\}$ 
42 on releaseDeposit( $txo, a_{btc}$ )
43   assert  $txo \in freeDeps$  /* verify deposit is free */
44   assert  $btcPrivs(txo.btcAddress)$  exists
45    $tx \leftarrow$  generate tx spending  $txo$  into  $a_{btc}$  using
     $btcPrivs(txo.btcAddress)$ 
46    $freeDeps \leftarrow freeDeps \setminus \{txo\}$ 
47   return  $tx$ 
48 on approveMyDeposit( $K_{remote}, txo$ )
49   assert  $net_{aes}(K_{remote})$  exists
50   assert  $txo \in freeDeps$ 
51   assert  $txo \notin appDeps(K_{remote})$ 
52   return ( $approveMyDeposit, K_{remote}, txo$ ) signed by  $k_{me}$ .
53 on receive ( $approveMyDeposit, K_{remote}, txo$ ) signed
    by  $k$  for  $K_{remote}$ 
54   assert  $net_{aes}(K_{remote})$  exists
55   assert  $txo \notin appDeps(K_{remote})$ 
56   Verify that  $txo$  is in the blockchain
57    $appDeps(K_{remote}) \leftarrow appDeps(K_{remote}) \cup \{txo\}$ 
58   return ( $approvedDeposit, K_{me}, txo$ ) signed using
     $k_{me}$ 
59 on receive ( $approvedDeposit, K_{remote}, txo$ ) signed by
     $k$  for  $K_{remote}$ 
60   assert  $net_{aes}(K_{remote})$  exists
61   assert  $txo \in freeDeps$ 
62   assert  $txo \notin appDeps(K_{remote})$ 
63    $appDeps(K_{remote}) \leftarrow appDeps(K_{remote}) \cup \{txo\}$ 
64 on associateMyDeposit( $id, txo$ )
65   assert  $c_{is\_open}(id) = True$ 
66   assert  $txo \in appDeps(c_{remote\_K}(id))$ 
67   assert  $txo \in freeDeps$ 
68    $freeDeps \leftarrow freeDeps \setminus \{txo\}$ 
69    $c_{my\_deps}(id) \leftarrow c_{my\_deps}(id) \cup \{txo\}$ 
70    $c_{my\_bal}(id) \leftarrow c_{my\_bal}(id) + txo.amount$ 
71    $K_{remote}^{enc} \leftarrow c_{remote\_K}(id)$ 
72    $k_{btc}^{enc} \leftarrow btcPrivs(txo.btcAddress)$  encrypted under
     $net_{aes}(K_{remote})$ 
73   return ( $associatedDeposit, id, txo, k_{btc}^{enc}$ ) signed
    using  $k_{me}$ 
74 on receive ( $associatedDeposit, id, txo, k_{btc}^{enc}$ ) signed
    by  $k$  for  $c_{remote\_K}(id)$ 
75   assert  $c_{is\_open}(id) = True$ 
76   assert  $txo \in appDeps(c_{remote\_K}(id))$ 
77    $c_{remote\_deps}(id) \leftarrow c_{remote\_deps}(id) \cup \{txo\}$ 
78    $c_{remote\_bal}(id) \leftarrow c_{remote\_bal}(id) + txo.amount$ 
79    $K_{remote} \leftarrow c_{remote\_K}(id)$ 
80    $k_{btc} \leftarrow k_{btc}^{enc}$  decrypted under  $net_{aes}(K_{remote})$ 
81    $btcPrivs(txo.btcAddress) \leftarrow k_{btc}$ 
82 on pay( $id, amount$ )
83   assert  $c_{my\_bal}(id) \geq amount$ 
84    $c_{my\_bal}(id) \leftarrow c_{my\_bal}(id) - amount$ 
85    $c_{remote\_bal}(id) \leftarrow c_{remote\_bal}(id) + amount$ 
86   return ( $paid, id, amount$ ) signed using  $k_{me}$ 
87 on receive ( $paid, id, amount$ ) signed by  $k$  for
     $c_{remote\_K}(id)$ 
88    $c_{my\_bal}(id) \leftarrow c_{my\_bal}(id) + amount$ 
89    $c_{remote\_bal}(id) \leftarrow c_{remote\_bal}(id) - amount$ 
90 on dissociateDeposit( $id, txo$ )
91   assert  $txo \in c_{my\_deps}(id)$ 
92   assert  $c_{my\_bal}(id) \geq txo.amount$ 
93   return ( $dissociatedDeposit, id, txo$ ) signed
    using  $k_{me}$ 
94 on receive ( $dissociatedDeposit, id, txo$ )
    signed by  $k$  for  $c_{remote\_K}(id)$ 
95   assert  $txo \in c_{remote\_deps}(id)$ 
96   assert  $c_{remote\_bal}(id) \geq txo.amount$ 
97    $c_{remote\_deps}(id) \leftarrow c_{remote\_deps}(id) \setminus \{txo\}$ 
98    $c_{remote\_bal}(id) \leftarrow c_{remote\_bal}(id) - txo$ 
99   return ( $dissociatedDepositAck, id, txo$ )
    signed using  $k_{me}$ 
100 on receive ( $dissociatedDepositAck, id, txo$ )
    signed by  $k$  for  $c_{remote\_K}(id)$ 
101    $c_{my\_deps}(pubKey) \leftarrow c_{my\_deps}(pubKey) \setminus \{txo\}$ 
102    $c_{my\_bal}(id) \leftarrow c_{my\_bal}(id) - txo$ 
103    $freeDeps \leftarrow freeDeps \cup \{txo\}$ 
104    $btcPrivs(txo.btcAddress) \leftarrow \perp$ 
105 on settle( $id$ )
106   if  $c_{my\_bal}(id) = \sum_{id}^n (c_{my\_deps}(id).amount) \wedge$ 
     $c_{remote\_bal}(id) = \sum_{id}^n (c_{remote\_deps}(id).amount)$  then
107      $\forall tx \in c_{my\_deps}(id) : dissociateDeposit(tx)$ 
108     Notify remote to dissociate all deposits.
109   if  $c_{my\_deps}(id) = \perp \wedge c_{remote\_deps}(id) = \perp$  then
110     /* Remote dissociated deps.
111     Terminate off-chain. */
112      $\forall i : c_i(id) \leftarrow \perp$  /* Reset all channel state */
113   else
114      $allDepAddrs \leftarrow \forall tx \in (c_{my\_deps}(id) \cup$ 
     $c_{remote\_deps}(id)) : return tx.btcAddress$ 
115      $tx \leftarrow$  generate signed tx spending:
     $c_{my\_bal}(id)$  into  $c_{my\_add}(id)$  &
116      $c_{remote\_bal}(id)$  into  $c_{remote\_add}(id)$  using:
     $btcPrivs(allDepAddrs)$ 
117      $\forall i : c_i(id) \leftarrow \perp$  /* Reset all channel state */
118     Notify remote that I terminated.
119     return  $tx$ 

```

value p_1 have been made, the free collateral is $v_1 - p_1 = x_1$. If x_1 is large, there is a high collateral lock-in. To avoid this, a participant can associate another deposit d_2 of value v_2 , where $v_1 > v_2 > p_1$, with c and dissociate d_1 from c , reducing the collateral lock-in. If the participant requires access to d_1 , the deposit can be released, or assigned to a different channel.

Off/on-chain channel termination. At any time, either party may settle payment channels (settle, line 105). If the balances of the parties are *neutral* i.e. equivalent to their deposits as though no payments have been made, Teechain can terminate the channel off-chain, by simply dissociating the deposits (line 107). Off-chain termination allows the funds to become available immediately, with fewer transactions placed onto the blockchain (see §7.5); otherwise, a settlement transaction is returned (line 115).

5 Teechain multi-hop payments

Teechain supports multi-hop payments along paths of payment channels in the network. To prevent fund loss, all channels in the path must update their balances consistently. Teechain achieves this without assuming synchronous blockchain access or freezing payment channels to prevent settlement. Instead, Teechain introduces *proofs of premature termination (PoPTs)*—if a participant prematurely terminates a channel during a multi-hop payment, all other participants in the path present their TEE with a *PoPT* to determine the state at which termination occurred.

If a multi-hop payment executes successfully, participants do not need to interact with the blockchain. Blockchain interaction is only required if a participant terminates a channel prematurely. In this case, the TEEs in the path authorize the

Algorithm 2: Teechain multi-hop payment protocol execution at TEE p_i (For brevity, we omit encryption, integrity and freshness protection of messages. TEEs in the path are numbered $1 \dots n$. Overlined variables are signed by the corresponding private key. \perp represents null.)

```

1  $\overline{\tau}_i \leftarrow \perp$ 
2  $amnt_i \leftarrow \perp$ 
3 on payMultihop ( $amount, p_1, \dots, p_n$ )
4 | send ( $p_1, lock, amount, p_1, \dots, p_n, \tau()$ )
5 on receive ( $lock, amount,$ 
6  $p_1, \dots, p_n, \tau(p_1, \dots, p_{i-1})$ )
7 | assert  $C_{(p_i, p_{i+1})}^{stage} = idle$ 
8 | assert  $C_{(p_i, p_{i+1})}^{myBal} \geq amount$ 
9 |  $amnt_i \leftarrow amount$ 
10 | if  $i < n$  then
11 |  $C_{(p_i, p_{i+1})}^{stage} \leftarrow lock$ 
12 | send ( $p_{i+1}, lock, p_1, \dots, p_n, \tau$ 
13 | ( $p_1, \dots, p_i$ ))
14 | else /*  $i = n$  */
15 |  $C_{(p_{n-1}, p_n)}^{stage} \leftarrow sign$ 
16 | send ( $p_{n-1}, sign, \tau(p_1, \dots, p_{n-1}, \overline{p}_n)$ )
17 on receive
18 ( $sign, \tau(p_1, \dots, p_i, \overline{p_{i+1}}, \dots, \overline{p}_n)$ )
19 | assert  $C_{(p_i, p_{i+1})}^{stage} = lock$ 
20 | if  $i > 1$  then
21 |  $C_{(p_i, p_{i+1})}^{stage} \leftarrow sign$ 
22 | send ( $p_{i-1}, sign, \tau(p_1, \dots, p_{i-1},$ 
23 |  $\overline{p}_i, \dots, \overline{p}_n)$ )
24 | else /*  $i = 1$  */
25 |  $\overline{\tau}_i \leftarrow \tau(\overline{p}_1, \dots, \overline{p}_n)$ 
26 |  $C_{(p_1, p_2)}^{stage} \leftarrow preUpdate$ 
27 | send ( $p_2, preUpdate, \overline{\tau}_i$ )
28 on receive ( $preUpdate, \overline{\tau}$ )
29 | assert  $C_{(p_i, p_{i+1})}^{stage} = sign$ 
30 |  $\overline{\tau}_i \leftarrow \overline{\tau}$ 
31 | if  $i < n$  then
32 |  $C_{(p_i, p_{i+1})}^{stage} \leftarrow preUpdate$ 
33 | send ( $p_{i+1}, preUpdate, \overline{\tau}$ ).
34 | else /*  $i = n$  */
35 |  $C_{(p_{n-1}, p_n)}^{stage} \leftarrow update$ 
36 |  $C_{(p_{n-1}, p_n)}^{myBal} \leftarrow C_{(p_{n-1}, p_n)}^{myBal} + amnt_i$ 
37 |  $C_{(p_{n-1}, p_n)}^{myBal} \leftarrow C_{(p_{n-1}, p_n)}^{myBal} - amnt_i$ 
38 | send ( $p_{n-1}, update$ )
39 on receive ( $update$ )
40 | assert  $C_{(p_i, p_{i+1})}^{stage} = preUpdate$ 
41 | if  $i > 1$  then
42 |  $C_{(p_i, p_{i+1})}^{stage} \leftarrow update$ 
43 |  $C_{(p_i, p_{i+1})}^{myBal} \leftarrow C_{(p_i, p_{i+1})}^{myBal} + amnt_i$ 
44 |  $C_{(p_i, p_{i+1})}^{myBal} \leftarrow C_{(p_i, p_{i+1})}^{myBal} - amnt_i$ 
45 | send ( $p_{i-1}, update$ )
46 | else /*  $i = 1$  */
47 |  $\overline{\tau}_i \leftarrow \perp$ 
48 |  $C_{(p_1, p_2)}^{stage} \leftarrow postUpdate$ 
49 | send ( $p_2, postUpdate$ )
50 on receive ( $postUpdate$ )
51 | assert  $C_{(p_i, p_{i+1})}^{stage} = update$ 
52 | if  $i < n$  then
53 |  $\overline{\tau}_i \leftarrow \perp$ 
54 |  $C_{(p_i, p_{i+1})}^{stage} \leftarrow postUpdate$ 
55 | send ( $p_{i+1}, postUpdate$ )
56 | else /*  $i = n$  */
57 |  $C_{(p_{n-1}, p_n)}^{stage} \leftarrow idle$ 
58 |  $C_{(p_{n-1}, p_n)}^{myBal} \leftarrow C_{(p_{n-1}, p_n)}^{myBal} + amnt_i$ 
59 |  $C_{(p_{n-1}, p_n)}^{myBal} \leftarrow C_{(p_{n-1}, p_n)}^{myBal} - amnt_i$ 
60 | send ( $p_{n-1}, release$ )
61 on receive ( $release$ )
62 | assert  $C_{(p_i, p_{i+1})}^{stage} = postUpdate$ 
63 |  $C_{(p_i, p_{i+1})}^{stage} \leftarrow idle$ 
64 | if  $i > 1$  then
65 | send ( $p_{i-1}, release$ )
66 on eject
67 |  $s \leftarrow C_{(p_i, p_{i+1})}^{stage}$ 
68 |  $C_{(p_i, p_{i+1})}^{stage} \leftarrow terminated$ 
69 | if  $s = lock \vee s = sign \vee s =$ 
70 |  $postUpdate \vee s = release$  then
71 | return  $C_{(p_{i-1}, p_i)}^{current.tx}$  and  $C_{(p_i, p_{i+1})}^{current.tx}$ 
72 | return  $\overline{\tau}$ 
73 on eject ( $popt$ )
74 |  $s \leftarrow C_{(p_i, p_{i+1})}^{stage}$ 
75 |  $C_{(p_i, p_{i+1})}^{stage} \leftarrow terminated$ 
76 | if  $popt = lock \vee popt = sign$  then
77 | return  $C_{(p_{i-1}, p_i)}^{pre-pay.tx}$  and  $C_{(p_i, p_{i+1})}^{pre-pay.tx}$ 
78 | else if  $popt = postUpdate \vee$ 
79 |  $popt = release$  then
80 | return  $C_{(p_{i-1}, p_i)}^{post-pay.tx}$  and  $C_{(p_i, p_{i+1})}^{post-pay.tx}$ 

```

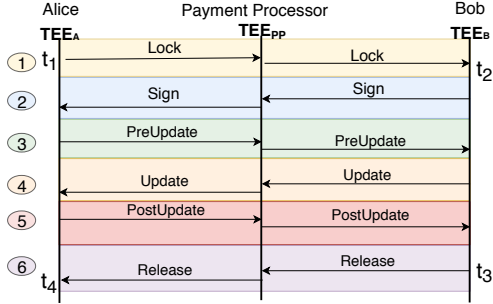

Figure 2: Overview of multi-hop payment protocol

generation of settlement transactions consistent with those of the prematurely terminated channel using *PoPTs*. As multiple settlement transactions may be generated for the same channel by different participants, Teechain generates conflicting blockchain transactions to ensure consistent termination states for all channels.

5.1 Multi-hop payment protocol

Fig. 2 shows the messages exchanged between TEEs when Alice routes a payment to Bob via Payment Processor. Alg. 2 describes the protocol executed at each TEE. To issue the payment, Alice executes `payMultihop` (Alg. 2, line 3), locking the payment channels in the path by forwarding a `lock` request along the channels (Fig. 2, stage 1 and Alg. 2, line 5). Channel locks prevent channels from being used for other payments and ensure sufficient balances. The TEEs in the path then update all channel states from *pre-payment* to *post-payment state* (Fig. 2, stages 2–5 and Alg. 2, line 15–line 54). Once all payment channels are updated, the channel locks are

released (Fig. 2, stage 6 and Alg. 2, line 55).

Proofs of premature termination (PoPT). At any time, a participant may eject (lines 60 and 66) from the protocol, prematurely terminating their payment channels. Teechain employs *PoPTs* during the update of channel balances to avoid inconsistent termination. When transitioning a set of payment channels from payment state X to Y , if a node prematurely terminates through `eject` (line 60), *PoPTs* ensure that all other nodes terminate at the same state. Teechain enforces that settlement transactions produced by channels in state X conflict with those of channels in Y . Hence, only transactions from either X or Y are accepted by the blockchain, but never both. TEEs operating channels in the conflicting state must be presented with a settlement transaction s of a channel settled in the opposite state; s acts as a *PoPT* to `eject` (line 66), authorizing the TEE to generate a new nonconflicting transaction to settle consistently (lines 70 and 72).

Enforcing transaction conflicts. For consistent channel settlement, Teechain must ensure that transactions in state X conflict with those in state Y . For blockchains offering expressive on-chain programmability, e.g. Ethereum, this can be achieved through a smart contract that associates settlement transactions for channels as part of a single multi-hop payment. For blockchains without smart contracts, e.g. Bitcoin, Teechain constructs an intermediate *path settlement transaction*, τ , that conflicts with individual pre- and post-payment transactions by spending the same deposits and settling all channels in the path at post-payment state. Using τ , channels can be updated from pre- to post-payment state securely, by moving to an intermediate state I between the transition. As I settles channels using τ , transitions from pre-payment state

to I , and I to post-payment state can occur safely because τ conflicts with all individual settlement channel transactions.

Termination consistency using τ and PoPTs. Using τ and *PoPTs*, Teechain settles channels consistently under premature termination. To construct τ , each TEE adds their channel deposits and post-payment balances (lock, line 11) and signs τ (sign, lines 14 and 19), producing $\bar{\tau}$. Upon receipt of $\bar{\tau}$ (preUpdate, lines 21 and 26), each TEE prevents individual channel settlement, and only allows premature termination through $\bar{\tau}$. If all nodes receive $\bar{\tau}$ successfully, the channel balances are updated to post-payment state (update, lines 32, 38 and 39), after which each TEE discards $\bar{\tau}$ and allows termination of individual channels at post-payment state (line 64). Channels locks are then released (release, line 46).

We differentiate three cases in which a participant prematurely terminates the protocol: (i) stage lock or sign—the TEE generates pre-payment settlement transactions for its *local* channels (line 64), and the participant places them on the blockchain. All other participants use these transactions on the blockchain as *PoPT* for their TEEs (line 66) to settle *their* channels in pre-payment state (line 70); (ii) preUpdate or update—if a participant ejects, their TEE settles *all* channels using $\bar{\tau}$ (line 65); and (iii) postUpdate or release—similar to (i), the TEE generates post-payment settlement transactions for its *local* channels (line 64) and the participant places them on the blockchain. Other participants use these transactions as *PoPT* for their TEEs (line 66) to settle *their* channels in post-payment state (line 72).

5.2 Overcoming channel lock contention

Locking payment channels during multi-hop payments (§5.1) prevents concurrent payments along the channels in that path. To overcome this bottleneck, Teechain constructs *temporary* channels between TEEs, allowing other payments to execute in parallel along the same paths. If a *primary* channel experiences high contention, temporary channels are created automatically using unassociated deposits. This is possible because Teechain can immediately create new channels and dynamically assign deposits (§4.1).

If a participant, *Alice*, wants to terminate any temporary channels, they can be merged back into a single primary channel: *Alice* (i) executes multi-hop payments in a cycle to herself along the primary and temporary channels until the temporary channels are at a neutral balance; and (ii) terminates the temporary channels off-chain through deposit dissociation (§4.1). We evaluate temporary channel performance in §7.4.

6 Chain replication and threshold signatures

TEEs in Teechain secure private keys for deposits. TEE failures and compromises therefore pose a threat to fund safety. Teechain uses a new variant of *chain replication* [68] to protect against crash and Byzantine failures of TEEs. Chain

replication offers high availability and strong consistency, without requiring all nodes to communicate with each other directly. In peer-to-peer networks, such as Teechain, this is advantageous to other protocols, such as Paxos [35], because not all participants have direct connectivity due to network address translation (NAT) and firewalls.

Force-freeze chain replication. Traditional chain replication replicates the state of a *primary* node to a set of *backup* replicas [68], propagating state updates down the replication chain and allowing read access from any backup. Applying this approach naively to TEEs would make Teechain vulnerable to roll-back and state forking attacks—attackers could attain old states and transactions from a backup, continue to execute payments via the primary, and then terminate at a previous state to steal funds. To overcome this, Teechain uses a new *force-freeze chain replication* protocol that exploits the chain replication structure: if a read access occurs to a backup, the chain is broken, freezing all nodes at the current state, similar to how failures are handled: future updates are prevented, and all channels are settled and unused deposits released—performed by contacting any live nodes in the chain.

Alg. 3 shows the force-freeze chain replication protocol for creating a replication chain and executing state updates: to create a backup b , a new TEE is initialized and assigned to the tail t of an existing replication chain (assignAsBackupFor, Alg. 3, line 7). Upon initialization, b and t perform remote attestation (lines 4 and 9) and establish a secure network channel (see §4) to begin replicating state. All TEEs in the chain are kept synchronized by requiring an acknowledgement from the backup before any state updates occur (line 24): updates propagate down the chain, updating all backups, and once the primary receives an acknowledgement from its backup, it knows that all backups in the chain have been updated, and can proceed to update (line 25) and continue (line 27).

6.1 Committee chains for secure deposits

Teechain secures fund deposits against Byzantine TEE failures by combining force-freeze chain replication with *threshold signatures* [19] to construct *committee chains*. Committee chains distribute deposit state among multiple TEEs in the network and exploit m -out-of- n multisignature blockchain transactions to require threshold signatures to spend deposits.

Committee deposit creation. Committee chains are constructed per fund deposit in Teechain: participants create deposits by spending funds into an m -out-of- n multisignature address on the blockchain, where m is the threshold number of signatures required to spend the deposit, and n the total number of committee members in that committee chain.

Alg. 1 shows the construction of 1-out-of-1 deposits, where only a single private key is used to secure each deposit. The protocol for constructing general m -out-of- n deposits is identical: first, a committee chain is constructed according to Alg. 3; next, each of the n TEEs in the committee chain return

Algorithm 3: Force-freeze chain replication protocol: backup assignment and state update at TEE t (For brevity, we omit the encryption, signing and nonce protection of messages.)

```

1 /* Check given remote attestation */
2 /* and return own attestation. */
3 on receive(Attest, h)
4   if verify(h) then
5     return hash(t)
6   return ⊥

7 on assignAsBackupFor(p)
8   assert tbacks = ⊥
9   assert verify(send(p, Attest, hash(t)))
10  if send(p, addBackup, t)(h) then
11    tbacks ← p /* Backup success */
12  else
13    fail

14 /* Handle incoming backup */
15 /* request and respond. */
16 on receive(addBackup, b)
17   if tbackup = ⊥ then
18     tbackup ← b
19     return ack
20   return nack

21 on receive(stateUpdate, s)
22   if tbackup ≠ ⊥ then
23     /* Block until recv ack */
24     send(tbackup, stateUpdate, s)
25     tstate ← s /* Update state */
26   if tnode = primary then
27     return true
28   return ack /* Ack s update */

```

a cryptocurrency address from command `newAddr` (Alg. 1, line 32); and, finally, participants spend funds into an m -out-of- n multisignature address for the committee members, and present the deposit to their primary TEE (`newDeposit`, Alg. 1, line 36), which notifies all the TEEs in the committee chain

Dynamic deposit assignment. Deposits can be created independently of payment channels (§4) and associated/dissociated with channels at runtime. Before channel association, deposits must first be approved by the remote party in the channel (`approveMyDeposit`, Alg. 1, line 48). This allows participants to accept deposits only if the values of m and n are appropriate. The security requirements can be defined in the local TEE of each participant, allowing automatic deposit approval. When selecting values, there are multiple considerations: (i) 1-out-of-1 deposits require the private key for the deposit to be shared with the remote TEE in the channel on association (Alg. 1, line 73). This avoids having to trust the counter party entirely for availability (see §4.1); (ii) 1-out-of- m committee deposits offer fault tolerance against crash but not Byzantine failures; and (iii) in the general case, to spend committee deposits, a participant must acquire a sufficient number of signatures for each deposit. Having many deposits per payment channel, with large values of m for each deposit, impacts blockchain transactions sizes; we explore this in §7.5.

Independent committee updates. Payment channels may contain multiple deposits, and each deposit may have a separate and independent committee chain. Teechain avoids having to update multiple committee chains atomically when participants issue large payments that affect the states of multiple deposits. Teechain enforces that, for any large payment that spans several deposits, the committee chains for those deposits must be identical, and thus the deposits state updates can be batched together securely. If a large payment spans deposits owned by separate committee chains, the payment is broken down into smaller payments, only affecting one deposit at a time, and executed sequentially. Having many deposits in a payment channel, each with distinct committee members, affects performance, which we evaluate in §7.2.

6.2 Persistent storage for crash faults

For users who do not wish to operate committee chains and instead trust TEEs to be secure against compromise entirely,

Teechain provides crash fault tolerance by persisting TEE and deposit state to local storage; upon failure, state can be reloaded to settle channels and return deposits. To overcome roll-back and state forking attacks, Teechain uses hardware monotonic counters [25] and secure data sealing provided by the TEE [3]. Since Intel SGX implementations currently throttle monotonic counters to ten increments per second [57, 41], persistent storage for crash fault tolerance is limited to ten operations per second. We overcome this using client-side transaction batching, as discussed and shown in §7.2.

7 Evaluation

We evaluate the security of Teechain (§7.1) and the performance of payment channels (§7.2), multi-hop payments (§7.3) large-scale payment networks (§7.4), and the on-blockchain cost (§7.5).

Implementation. We implement Teechain using Intel SGX for the Bitcoin blockchain. Our implementation uses the Linux Intel SGX SDK v2.1 [22] and a subset of Bitcoin core [61]. We provide an alpha release of our implementation online at: [redacted for anonymity]. Teechain consists of 83,000 lines of C/C++ code inside the TEE, and 5,000 lines of untrusted code. As the Linux SGX SDK does not currently support monotonic counters on all hardware [22], we emulate them with a delay of 100 ms, as reported elsewhere [57, 41].

Baseline comparison. To measure performance, we define throughput as the number of transactions sent per second, and latency as the time from the moment a payment is issued until an acknowledgement is received. At the time of writing, the only payment network with a public implementation is the Lightning Network (LN) [50]. We compare Teechain against the Lightning Network Daemon (LND) [37]. Both LN and Teechain can optionally batch transactions at the client side, merging multiple payments into a single payment before sending—at the cost of additional latency.

7.1 Security

Protocol correctness. Teechain achieves *balance correctness*: the ability for any user to unilaterally reclaim their channels’ balances and unassociated deposits on the blockchain,

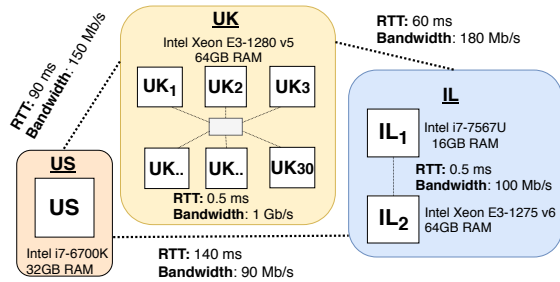

Figure 3: Setup for evaluating Teechain performance

regardless of what actions other users may take. We provide a brief outline of the correctness proof below—see Appendix A for the formal definitions and full proofs.

We describe, using the Universal Composability (UC) framework [11], an ideal functionality $\mathcal{F}_{Teechain}$, that captures the desired behavior of the Teechain protocols. We define an API for the Teechain functionality, e.g. procedures for handling deposits, channels creation, and payments. We show, through a series of steps starting at the real-world execution and ending in the ideal one, that the real and ideal worlds are indistinguishable to an external observer (or adversary). Finally, we prove in the ideal-world that $\mathcal{F}_{Teechain}$ achieves balance correctness. Since the two worlds are indistinguishable, Teechain in the real-world maintains the same security properties, thus achieving balance correctness.

Roll-back, replay and state forking attacks. Teechain mitigates against roll-back, replay and TEE state forking attacks: (i) it authenticates TEEs and establishes secure network channels using public/private keys generated inside the TEE to prevent messages from being shared between different TEE instances (§4.1); (ii) it uses nonces or monotonic counters for message freshness (§4.1 and §5.1); and (iii) it employs a fault tolerance mechanism that protects against Byzantine TEEs using committee chains (§6).

Denial-of-service (DoS) attacks. DoS attacks against specific TEEs in the network are possible e.g. attackers can block communication between endpoints in the network, eclipse nodes to prevent blockchain access, or force failures along committee chains to degrade performance. To overcome this, Teechain protects against DoS attacks through asynchronous blockchain access and fault tolerance, ensuring DoS attacks do not affect fund safety.

Side-channel attacks. Side-channel attacks violate data confidentiality inside a TEE [67, 71]. Such attacks are one instance of a TEE compromise, for which Teechain mitigates using committee chains (§6). Our Teechain implementation also hardens against side-channel attacks using side-channel resistant libraries for sensitive data: (i) secp256k1, for elliptic curve operations [60]; (ii) a side-channel resistant implementation of Elliptic-Curve Diffie-Hellman [64]; and (iii) a secure AES-GCM implementation using AES-NI [64, 22]. We use program analysis techniques [39] to verify the correct handling of sensitive data by these libraries.

Single payment channel	Throughput (tx/sec)	Latency (ms)	[99th %]
<i>Lightning Network (LN)</i>	1,000	387	[420]
<i>Teechain</i>			
No fault tolerance	130,311	86	[93]
One replica (IL)	34,115	292	[301]
Two replicas (IL & UK)	33,180	415	[432]
Three replicas (IL, US & UK)	33,178	672	[691]
Outsourced channel, two replicas	33,178	483	[494]
Stable storage	10	288	[294]
Batching (no fault tolerance)	150,311	191	[196]
Batching (two replicas)	135,331	516	[530]
Batching (stable storage)	145,786	401	[408]

Table 1: Performance of payment channels

7.2 Performance of payment channels

We measure the performance of Teechain payment channels. We answer three questions: (i) what is the maximum throughput of a Teechain payment channel? (ii) how does fault tolerance affect channel performance? and (iii) how does transaction batching affect throughput?

Experimental setup. We deploy Teechain on 33 SGX machines located in the UK, the US, and Israel. Fig. 3 shows the network configurations, machine locations, and hardware. We construct a payment channel between *US* and *UK*₁. To evaluate outsourced channels, *IL*₁ acts as a non-SGX client that constructs an outsourced channel between *US* and *UK*₁.

In all experiments, both parties in the channel employ the same fault tolerance strategy, i.e. both use committee chains of the same length because performance is bound by the slowest party. We vary the lengths n for m -out-of- n committee chains and note that the value of m does not affect channel throughput as all n committee members must replicate the state regardless. When batching transactions in Teechain, we batch for 100 ms before sending a single transaction. Teechain requires one round-trip for a payment to complete, while LN requires two. While Teechain can pipeline payments, LN only supports sequential transactions and must batch by default.

Channel performance. Tab. 1 shows the average throughput and latency. LN achieves a maximum throughput of 1,000 tx/sec, with a latency of 387 ms (99th percentile at 420 ms). Without fault tolerance, with deposits only secured by a single committee member ($n=1$), Teechain has two orders of magnitude higher throughput with a latency of 86 ms (no batching). With two committee members (i.e. a single replica in Israel) for each party, the throughput of Teechain is 34× compared to LN, with similar latencies. Adding additional committee members to each party’s committee chain only increases latency due to additional RTTs—throughput is unchanged. Using stable storage, performance is capped by the hardware counters, resulting in 10 tx/sec, which can be overcome by transaction batching. Teechain achieves between 135×–150× better performance than LN when batching.

Channel operations. Tab. 2 shows the performance of chan-

Channel operation	Latency (ms) [99th %]	
	Local	Outsourced
<i>Lightning Network (LN)</i>		
Channel creation	3,600,000	[N/A]
<i>Teechain</i>		
Channel creation	2,810 [4,205]	4,322 [5,201]
Replica creation	2,765 [3,910]	2,852 [3,993]
Associate/dissociate deposit		
No fault tolerance	101 [110]	
One backup (IL)	289 [297]	
Two backups (IL & UK)	422 [429]	489 [514]
Three backups (IL, US & UK)	677 [681]	
Stable storage	302 [309]	

Table 2: Performance of payment channel operations

nel operations. LN channel creation takes approx. 60 mins, as a transaction must be placed onto the blockchain and confirmation takes six Bitcoin blocks. Since Teechain decouples channels and deposits, channel creation takes only 2.8 secs, as deposits are already on the blockchain. Creation of an outsourced payment channel takes 4.3 secs, as the client (IL_1) also needs to verify the integrity of the outsourced TEE (US). Creating replicas and adding them to committee chains incurs similar latencies to channel creation. For associating and dissociating deposits, latencies depend committee chain length n .

Discussion. Channel throughput in Teechain is affected by fault tolerance: (i) without batching, no fault tolerance provides best performance, and stable storage performs worst due to hardware counters; (ii) with batching, Teechain achieves higher throughput for all fault tolerance mechanisms, even stable storage, because transactions can be batched while waiting for counters. Latencies are a function of the network, state replication, hardware counters and any batching delay.

7.3 Performance of multi-hop payments

Next we evaluate the performance of Teechain multi-hop payments. We use the same machines as in §7.2. We answer two questions: (i) how does latency increase with the number of hops in a payment chain? and (ii) how does fault tolerance affect payment chain performance?

Experimental setup. We construct 11 payment channels, all of which are transatlantic in the topology from Fig. 3. We send transactions along the chain $UK \rightarrow US \rightarrow IL \rightarrow UK$. For UK and IL , we split the payment channels equally between the machines to spread the load. All experiments use the same payment channel overlay network. All nodes in the multi-hop payment path use committee chains of the same length. Committee members are deployed in different failure domains, e.g. UK nodes are replicated to US and IL .

Multi-hop latency. We measure the latency of multi-hop payments. We vary the number of hops and the number of committee members per committee chain for each TEE. Fig. 4 shows that LN scales linearly with the length of the chain, taking 1 sec to complete a payment across 2 hops (2 channels)

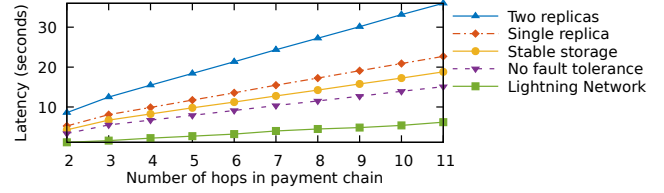

Figure 4: Routing across Teechain payment chains

and 7 secs for 11 hops. Teechain also scales linearly, but with different gradients: with no fault tolerance (i.e. committee chains of length 1), latency is about 2× that of LN. Using a single replica (i.e. committee chains of length 2 at each node), payments across 2 hops take 5 secs; payments across 11 hops take 23 secs. The 3×–4× overhead compared to LN is a due to the extra network round trips required for payment routing.

Multi-hop throughput. To update all channels in a multi-hop payment consistently, both Teechain and LN do not pipeline multi-hop payments. Therefore, throughput is $1/\text{latency}$. Teechain and LN thus batch transactions: throughput becomes the batch size divided by the latency to complete the payment. We compare throughput for Teechain and LN, with each Teechain node using two replicas. Teechain batches 135,000 tx/sec, while LN batches 1,000 tx/sec (see §7.2). With this, the throughput of Teechain for 2 hops is 14,062 tx/sec, while it is 3,649 tx/sec for 11 hops. For LN, throughput for 2 hops is 862 tx/sec, and 139 tx/sec for 11 hops. Teechain thus outperforms LN by between 16×–26× for between 2 and 11 hops, respectively.

Discussion. Teechain requires three round trips to complete a payment, while LN requires only 1.5. Teechain must synchronize nodes off-chain with additional messages to support asynchronous blockchain access. In addition, Teechain is network-bound: replicating state to committee members increases latency.

7.4 Performance of payment networks

We also evaluate the performance of a Teechain payment network. We use the 30 machines located in the UK (Fig. 3) to conduct our experiments. We answer two questions: (i) how does the overlay network topology affect throughput? and (ii) how does fault tolerance affect throughput?

Payment workload. As there exist no public micro-payment datasets, we use the transactions found in the Bitcoin blockchain. To adapt the Bitcoin transaction history, we filter out transactions that are not appropriate for replaying, such as those that spend to/from multi-signature addresses, or payments of value over a certain threshold (i.e. \$100). For transactions with multi-input and output addresses, we choose only one. This results in a dataset of over 150 million payments from a source to a recipient address.

Overlay network topologies. We construct two overlay payment network topologies: (i) a *complete* graph, in which all nodes in the network have a direct payment channel to

Approach	Avg. Throughput (tx/sec)	Avg. Latency (ms)	Avg. Num hops
No fault tolerance	671	540	3.2
One replica	210	720	3.2
Dynamic routing (No FT)	235	690	5.4
Dynamic routing (One replica)	54	910	5.4

Table 3: Performance with hub-and-spoke topology

all other nodes; and (ii) a *hub-and-spoke* topology, shown in Fig. 5, in which the nodes are connected with 3 tiers of connectivity: tier 1 nodes have highest connectivity and tier 3 nodes lowest connectivity. We emulate wide-area network links by adding 100 ms latency between each machine.

Experimental setup. To execute payments in the network, we assign Bitcoin addresses to the machines. For all payments, the machine assigned ownership over the sending address is responsible for issuing payments to the recipient addresses and corresponding machines. For the complete graph, we randomly and evenly distributing all Bitcoin addresses between the machines; for the hub-and-spoke graph, we distribute the addresses in a skewed fashion, with larger nodes being assigned more addresses than smaller nodes, as would be expected in a realistic deployment. We assign 50% of addresses to tier 1 nodes, 35% to tier 2, and 15% to tier 3.

For each graph deployment, we compare the throughput with differently sized committee chains, for $n = 1$ to $n = 3$ committee members per deposit. All machines in the graph operate the same fault tolerance mechanism per experiment. Measurement begins when the first payment is issued, and ends when an acknowledgement for the last payment is received. As payments may fail, e.g. due to channel locking, upon receiving a failure notification, the payment is retried after a random amount of time between 100 ms–200 ms. To bound the degree to which out-of-order payments can be executed, we implement a sliding window of payments at each machine. Each machine issues $W=1000$ payments across the network in parallel, and waits for acknowledgements before moving the sliding window.

Complete graph throughput. We execute the Bitcoin workload across several complete Teechain graphs. We vary the number of nodes in the deployment from 5 to 30 machines. Fig. 6 shows the achieved network throughput for each deployment. For all fault tolerant strategies, throughput scales linearly with the number of nodes. No fault tolerance ($n = 1$) performs best (2.2 million tx/sec with 30 machines), while the use of committee chains with $n > 1$ limits throughput (1 million tx/sec with 30 machines). There is little difference (9%) between $n = 2$ committee members per deposit and $n = 3$ —with chain replication, throughput is bottlenecked by the time taken to replicate state. We note that, in a complete graph deployment, there is no need for multi-hop payments.

Hub-and-spoke throughput. We execute the Bitcoin workload with the hub-and-spoke graph deployment from Fig. 5. For multi-hop payments, we use the shortest possible path—

if there are multiple, only one is chosen. Tab. 3 shows the results. Without fault tolerance ($n = 1$), the network achieves around 671 tx/sec, with an average payment latency of approx. 500 ms. With two committee members per deposit ($n = 2$), throughput is around 210 tx/sec, with slightly higher latencies. The average number of hops per payment is around 3.

Topology comparison. Payment throughput degrades significantly in the hub-and-spoke topology compared to the complete graph topology: more than 1000× when comparing the topologies with 20 machines and identical fault tolerance. This is a result of having to lock channels during multi-hop payments, forcing payments to compete for channels. To overcome this, we implement and evaluate two approaches to avoid locking contention: (i) *dynamic routing* to allow payments to execute across different paths in the graph, so as to route around contention; and (ii) *temporary channels* to allow concurrent payments between endpoints (see §5.2).

Dynamic routing. Tab. 3 shows the throughput when payments are retried using different paths. When retrying payments, each machine first tries the shortest path, before incrementally trying longer paths. Throughput with dynamic routing degrades by between 50%–70% depending on fault tolerance. This is a result of longer multi-hop paths, locking up more channels; seen by more hops per payment on average.

Temporary channels. Fig. 7 shows how throughput increases when tier 1 and 2 nodes in the hub-and-spoke graph support temporary channel creation. We avoid temporary channels for tier 3 nodes because it is unlikely that individual users are willing to deposit funds. As seen, throughput scales almost linearly with the number of temporary channels (G), for both no fault tolerance ($n = 1$ committee members) and one replica ($n = 2$). The results show diminishing returns as G increases because tier 3 nodes still suffer from congestion.

Discussion. Locking channels during multi-hop payments creates contention: if high performance is required in a payment network, the graph must have high connectivity. Temporary channels can achieve this, however, performance is best when there is a direct payment channel between sender and recipient.

7.5 Blockchain cost

Payment networks place transactions on the blockchain to operate payment channels. We evaluate and compare: (i) the number of transactions that Teechain places onto the blockchain; and (ii) the associated blockchain cost.

We define the *blockchain cost* as the amount of data placed on the blockchain to open and close a payment channel. Unlike existing solutions, Teechain can assign multiple deposits to a single channel. For a fair comparison, we assume at most two deposits per channel. We abstract from particular blockchains and approximate cost by counting the pairs of public keys and signatures that must be placed onto the blockchain [9]: a cost of 1 means one public key and one signature.

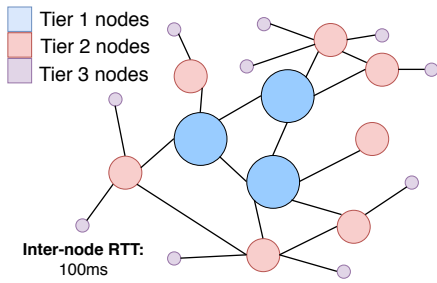

Figure 5: Hub-and-spoke overlay topology

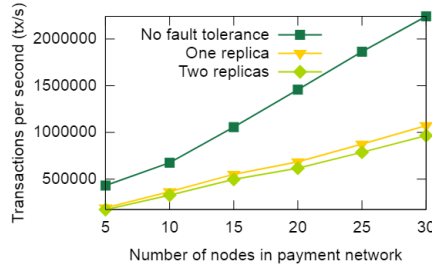

Figure 6: Throughput with complete graph topology

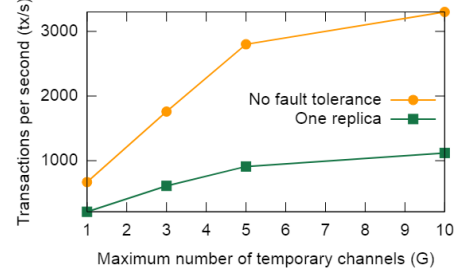

Figure 7: Throughput with temporary channels

Payment channel	Bilateral		Unilateral	
	#txs	cost	#txs	cost
LN [50]	4	6	4	6
DMC [15]	2	4	$1+d+2$	$2(1+d+2)$
SFMC [9]	$2/n$	$2p/n$	$(1+i)/n + (1+d+2)$	$(1+i)(p/n) + 2(1+d+2)$
Teechain	1	$1+(n/2)$	3	$1+(n_1/2)+1 + (n_2/2) + m_1 + m_2$

Table 4: Number of transactions and blockchain costs

Tab. 4 shows the number of transactions and the blockchain cost. For all solutions but LN, the number of transactions and the blockchain cost is higher if one party unilaterally closes the payment channel. For *Duplex Micropayment Channels (DMC)* [15], the number of transactions required for each channel ranges from 2 to $1+d+2$, where $d \geq 1$ defines the DMC transaction chain length. Since each DMC transaction requires 2 public keys and 2 signatures, the associated cost is the number of transactions multiplied by 2. In LN, 4 transactions must be placed onto the blockchain, which contain both 6 public keys and 6 signatures, thus resulting in a cost of 6 across bilateral and unilateral termination.

For *Scalable Funding of Micropayment Channels (SFMC)* [9], the number of transactions required for each channel ranges from $2/n$ to $(1+i)/n + (1+d+2)$, where n is the total number of constructed payment channels and $i \geq 1$ and $d \geq 1$ define the funding and transaction chain’s lengths. Since SFMC (i) constructs shared channel groups of size $p > 2$; and (ii) builds on DMC payment channels, it is possible that p parties do not collaboratively close payment channels. Since each SFMC transaction (i) requires p signatures and (ii) is shared between the n payment channels, this results in a blockchain cost of $2p/n$ for each payment channel if all parties collaboratively close payment channels; $(1+i)(p/n) + 2(1+d+2)$ for each payment channel if closed unilaterally.

Teechain constructs funding deposits using m -out-of- n transactions. If the channel has been funded by a single deposit and is settled off-chain, only one transaction is required, with the cost being $1+(n/2)$ —the cost of a signature and pub-

lic key to spend funds into the deposit address, and n public keys to specify the committee members. (We divide n by 2 as cost is defined in terms of both public keys and signatures together.) Otherwise, with two deposits assigned to a channel and on-chain settlement, Teechain requires 3 transactions, with the cost being the sum of the costs of the two funding deposits plus the settlement transaction.

Discussion. Assuming a 2-out-of-3 multisignature construction for each funding deposit, Teechain places 25%–75% fewer transactions on the blockchain than LN, and is up to 58% more efficient when comparing blockchain cost for bilateral termination. For unilateral termination, Teechain is 50% more expensive due to larger multisignature transactions. For DMC and bilateral closure, Teechain places 50% fewer transactions and 37% less data on the blockchain than DMC. For unilateral closure and $d > 1$, Teechain outperforms DMC.

While Teechain outperforms SMFC for all values of i , d , p and n , in the case of closing channels unilaterally, SMFC places fewer transactions and less data onto the blockchain if $n > 1$ and $p/n > 1$ and if all parties agree on closing payment channels. This is because SFMC shares transaction numbers and costs across multiple parties and channels, however, at the cost of having to trust all involved parties. Teechain, on the other hand, does not require any assumptions about the correct behaviour of other parties.

8 Conclusion

Teechain is the first blockchain payment network to operate with asynchronous blockchain access and offer dynamic collateral assignment; funds can be assigned to payment channels at runtime, and channels can be created instantly, without blockchain writes. Teechain mitigates against Byzantine TEE failures through a novel combination of chain replication and threshold secret sharing. We evaluated Teechain using Intel SGX on the Bitcoin blockchain; our results show orders of magnitude performance gains compared to the state of the art. Finally, Teechain is blockchain agnostic and the protocols presented are independent of any specific TEE implementation.

References

- [1] ALI, S. T., CLARKE, D., AND MCCORRY, P. The Nuts and Bolts of Micropayments: a Survey. *arXiv preprint arXiv:1710.02964* (2017).
- [2] AMAZON PAY. <https://pay.amazon.com/>.
- [3] ANATI, I., GUERON, S., JOHNSON, S., AND SCARLATA, V. Innovative Technology for CPU Based Attestation and Sealing. In *Proceedings of the 2nd International Workshop on Hardware and Architectural Support for Security and Privacy, HASP* (2013), vol. 13.
- [4] ARM LTD. TrustZone. <https://www.arm.com/products/security-on-arm/trustzone>. Accessed May 2017, 2017.
- [5] BARBOSA, M., PORTELA, B., SCERRI, G., AND WARINSCHI, B. Foundations of hardware-based attested computation and application to sgx. In *Security and Privacy (EuroS&P), 2016 IEEE European Symposium on* (2016), IEEE, pp. 245–260.
- [6] BENTOV, I., JI, Y., ZHANG, F., LI, Y., ZHAO, X., BREIDENBACH, L., DAIAN, P., AND JUELS, A. Tesseract: Real-time cryptocurrency exchange using trusted hardware. *IACR Cryptology ePrint Archive 2017* (2017), 1153.
- [7] BLOCKCHAIN.INFO. Average Confirmation Time. <https://blockchain.info/charts/avg-confirmation-time?timespan=all&daysAverageString=7>. Accessed May 2018, May 2018.
- [8] BRASSER, F., MÜLLER, U., DMITRIENKO, A., KOSTIAINEN, K., CAPKUN, S., AND SADEGHI, A.-R. Software grand exposure: Sgx cache attacks are practical. *arXiv preprint arXiv:1702.07521* (2017), 33.
- [9] BURCHERT, C., DECKER, C., AND WATTENHOFER, R. Scalable Funding of Bitcoin Micropayment Channel Networks. In *International Symposium on Stabilization, Safety, and Security of Distributed Systems* (2017), Springer, pp. 361–377.
- [10] CACHIN, C. Architecture of the Hyperledger Blockchain Fabric. In *Workshop on Distributed Cryptocurrencies and Consensus Ledgers* (2016).
- [11] CANETTI, R. Universally composable security: A new paradigm for cryptographic protocols. In *Foundations of Computer Science, 2001. Proceedings. 42nd IEEE Symposium on* (2001), IEEE, pp. 136–145.
- [12] CANETTI, R. Universally composable signature, certification, and authentication. In *Computer Security Foundations Workshop, 2004. Proceedings. 17th IEEE* (2004), IEEE, pp. 219–233.
- [13] CASTRO, M., LISKOV, B., ET AL. Practical Byzantine Fault Tolerance. In *OSDI* (1999), vol. 99, pp. 173–186.
- [14] CHENG, R., ZHANG, F., KOS, J., HE, W., HYNES, N., JOHNSON, N., JUELS, A., MILLER, A., AND SONG, D. Ekiden: A platform for confidentiality-preserving, trustworthy, and performant smart contract execution. *arXiv preprint arXiv:1804.05141* (2018).
- [15] DECKER, C., AND WATTENHOFER, R. A Fast and Scalable Payment Network with Bitcoin Duplex Micropayment Channels. In *Stabilization, Safety, and Security of Distributed Systems - 17th International Symposium, (SSS 2015)* (2015).
- [16] DWARFPOOL. Why DwarfPool mines mostly empty blocks and only few ones with transactions. https://www.reddit.com/r/ethereum/comments/57clyn/why_dwarfpool_mines_mostly_empty_blocks_and_only/. Accessed Feb 2018, 2016.
- [17] EYAL, I., GENCER, A. E., SIRER, E. G., AND VAN RENESSE, R. Bitcoin-NG: A scalable blockchain protocol. In *13th USENIX Symposium on Networked Systems Design and Implementation (NSDI 2016)* (2016).
- [18] GILAD, Y., HEMO, R., MICALI, S., VLACHOS, G., AND ZELDOVICH, N. Algorand: Scaling byzantine agreements for cryptocurrencies. In *Proceedings of the 26th Symposium on Operating Systems Principles* (2017), ACM, pp. 51–68.
- [19] GOLDFEDER, S., GENNARO, R., KALODNER, H., BONNEAU, J., KROLL, J. A., FELTEN, E. W., AND NARAYANAN, A. Securing bitcoin wallets via a new dsaeccdsa threshold signature scheme, 2015.
- [20] GREENSPAN, G. Multichain private blockchain-white paper. <http://www.multichain.com/download/MultiChain-White-Paper.pdf>, 2015.
- [21] HEARN, M., AND SPILMAN, J. Contract, 2016. <https://en.bitcoin.it/wiki/Contract>. Accessed May 2017.
- [22] INTEL. Intel Software Guard Extensions SDK for Linux OS. https://download.01.org/intel-sgx/linux-1.8/docs/Intel_SGX_SDK_Developer_Reference_Linux_1.8_Open_Source.pdf. Accessed May 2017, 2017.

- [23] INTEL CORP. Software Guard Extensions Programming Reference, Ref. 329298-002US. <https://software.intel.com/sites/default/files/managed/48/88/329298-002.pdf>, 2014.
- [24] INTEL INC. Intel Software Guard Extensions Remote Attestation End-to-End Example. <https://software.intel.com/en-us/articles/intel-software-guard-extensions-remote-attestation-end-to-end-example>. Accessed May 2017, 2016.
- [25] INTEL INC. `sgx_create_monotonic_counter`. <https://software.intel.com/en-us/node/709160>. Accessed May 2017, 2017.
- [26] JOHNSON, SIMON ET AL. Intel® Software Guard Extensions: EPID Provisioning and Attestation Services. <https://software.intel.com/en-us/blogs/2016/03/09/intel-sgx-epid-provisioning-and-attestation-services>, 2016.
- [27] JORDAN PEARSON. WikiLeaks Is Now a Target In the Massive Spam Attack on Bitcoin. https://motherboard.vice.com/en_us/article/ezvw7z/wikileaks-is-now-a-target-in-the-massive-spam-attack-on-bitcoin. Accessed Feb 2018, 2015.
- [28] JOSEPH YOUNG. Analyst: Suspicious Bitcoin Mempool Activity, Transaction Fees Spike to 16. <https://cointelegraph.com/news/analyst-suspicious-bitcoin-mempool-activity-transaction-fees-spike-to-16>. Accessed Feb 2018, 2017.
- [29] JP BUNTINX. F2Pool Allegedly Prevented Users From Investing in Status ICO. <https://themerkle.com/f2pool-allegedly-prevented-users-from-investing-in-status-ico/>. Accessed Feb 2018, 2017.
- [30] KAPLAN, D., POWELL, J., AND WOLLER, T. AMD Memory Encryption. *White paper* (2016).
- [31] KEYSTONE PROJECT. Keystone: Open-source secure hardware enclave. <https://keystone-enclave.org/>.
- [32] KHALIL, R., AND GERVAIS, A. Revice: Rebalancing Off-Blockchain Payment Networks. *Gas* 200, 400.
- [33] KOGIAS, E. K., JOVANOVIĆ, P., GAILLY, N., KHOFFI, I., GASSER, L., AND FORD, B. Enhancing Bitcoin Security and Performance with Strong Consistency via Collective Signing. In *25th USENIX Security Symposium (USENIX Security 16)* (2016).
- [34] KRAWCZYK, H. Sigma: The sign-and-mac approach to authenticated diffie-hellman and its use in the ike protocols. In *Annual International Cryptology Conference* (2003), Springer, pp. 400–425.
- [35] LAMPORT, L., ET AL. Paxos made simple. *ACM Sigact News* 32, 4 (2001), 18–25.
- [36] LEWENBERG, Y., SOMPOLINSKY, Y., AND ZOHAR, A. Inclusive Block Chain Protocols. In *Financial Cryptography* (Puerto Rico, 2015).
- [37] LIGHTNING NETWORK COMMUNITY. Lightning network daemon. <https://github.com/lightningnetwork/lnd>, retrieved May 2017, 2017.
- [38] LIND, J., EYAL, I., PIETZUCH, P., AND SIRER, E. G. Teechan: Payment channels using trusted execution environments. *arXiv preprint arXiv:1612.07766* (2016).
- [39] LIND, J., PRIEBE, C., MUTHUKUMARAN, D., O’KEEFFE, D., AUBLIN, P.-L., KELBERT, F., REIHER, T., GOLTZSCHE, D., EYERS, D., KAPITZA, R., FETZER, C., AND PIETZUCH, P. Glamdring: Automatic Application Partitioning for Intel SGX. In *Proceedings of the 2017 USENIX Conference on Usenix Annual Technical Conference* (Berkeley, CA, USA, 2017), USENIX ATC ’17, USENIX Association, pp. 285–298.
- [40] MALAVOLTA, G., MORENO-SANCHEZ, P., KATE, A., MAFFEI, M., AND RAVI, S. Concurrency and privacy with payment-channel networks, 2017.
- [41] MATETIC, S., AHMED, M., KOSTIAINEN, K., DHAR, A., SOMMER, D., GERVAIS, A., JUELS, A., AND CAPKUN, S. ROTE: Rollback Protection for Trusted Execution. *Cryptology ePrint Archive*, Report 2017/048, 2017. <http://eprint.iacr.org/2017/048>.
- [42] MAZIERES, D. The Stellar Consensus Protocol: A Federated Model for Internet-level Consensus. <https://www.stellar.org/papers/stellar-consensus-protocol.pdf>, 2015.
- [43] MILLER, A., BENTOV, I., KUMARESAN, R., AND MCCORRY, P. Sprites: Payment channels that go faster than lightning. *arXiv preprint arXiv:1702.05812* (2017).
- [44] MILLER, A., XIA, Y., CROMAN, K., SHI, E., AND SONG, D. The Honey Badger of BFT Protocols. In *Proceedings of the 2016 ACM SIGSAC Conference on Computer and Communications Security (CCS 2016)* (2016).
- [45] MOGHIMI, A., IRAZOQUI, G., AND EISENBARTH, T. Cachezoom: How sgx amplifies the power of cache attacks. In *International Conference on Cryptographic*

- Hardware and Embedded Systems* (2017), Springer, pp. 69–90.
- [46] NAKAMOTO, S. Bitcoin: A Peer-to-Peer Electronic Cash System. <http://www.bitcoin.org/bitcoin.pdf>, 2008.
- [47] PASS, R., AND SHI, E. Hybrid Consensus: Efficient Consensus in the Permissionless Model. *Cryptology ePrint Archive*, Report 2016/917, 2016.
- [48] PAYPAL. <https://www.paypal.com/>.
- [49] POON, J., AND BUTERIN, V. Plasma: Scalable autonomous smart contracts.
- [50] POON, J., AND DRYJA, T. The Bitcoin Lightning Network: Scalable off-chain instant payments. Technical Report (draft 0.5.9.1). <https://lightning.network>. Accessed May 2017, 2016.
- [51] SASSON, E. B., CHIESA, A., GARMAN, C., GREEN, M., MIERS, I., TROMER, E., AND VIRZA, M. Zerocash: Decentralized anonymous payments from bitcoin. In *Security and Privacy (SP), 2014 IEEE Symposium on* (2014), IEEE, pp. 459–474.
- [52] SCHUSTER, F., COSTA, M., FOURNET, C., GKANTSIDIS, C., PEINADO, M., MAINAR-RUIZ, G., AND RUSSINOVICH, M. Vc3: Trustworthy data analytics in the cloud using sgx. In *Security and Privacy (SP), 2015 IEEE Symposium on* (2015), IEEE, pp. 38–54.
- [53] SCHWARTZ, D., YOUNGS, N., BRITTO, A., ET AL. The ripple protocol consensus algorithm.
- [54] SECBIT. How the winner got Fomo3D prize A Detailed Explanation. <https://medium.com/coinmonks/how-the-winner-got-fomo3d-prize-a-detailed-explanation-b30a69b7813f>. Accessed Sep 2018, 2018.
- [55] SHI, E., ZHANG, F., PASS, R., DEVADAS, S., SONG, D., AND LIU, C. Trusted hardware: Life, the composable universe, and everything. *manuscript* (2015).
- [56] SOMPOLINSKY, Y., AND ZOHAR, A. Accelerating Bitcoin’s Transaction Processing. Fast Money Grows on Trees, Not Chains. In *Financial Cryptography* (Puerto Rico, 2015).
- [57] STRACKX, R., AND PIESSENS, F. Ariadne: A Minimal Approach to State Continuity. In *25th USENIX Security Symposium (USENIX Security 16)* (Austin, TX, 2016), USENIX Association, pp. 875–892.
- [58] SUPERFREEK. BTC Spam attack. 200,000 unconfirmed transactions halts bitcoin. <https://steemit.com/cryptocurrency/@superfreek/btc-spam-attack-200-000-unconfirmed-transactions-halts-bitcoin>. Accessed Feb 2018, 2017.
- [59] TEAM ROCKET. Snowflake to avalanche: A novel metastable consensus protocol family for cryptocurrencies. <https://ipfs.io/ipfs/QmUy4jh5mGNZvLkjies1RWM4YuvJh5-o2FYopNPVYwrRVGV>, 2018.
- [60] THE BITCOIN COMMUNITY. libsecp256k1. <https://github.com/bitcoin-core/secp256k1>.
- [61] THE BITCOIN COMMUNITY. Bitcoin Core version 0.13.1 released. <https://bitcoin.org/en/release/v0.13.1>. Accessed May 2017, 2016.
- [62] THE BITCOIN COMMUNITY. M-of-N Multisig, Multisig Output. <https://bitcoin.org/en/glossary/multisig>. Accessed May 2017, 2017.
- [63] THE ETHEREUM COMMUNITY. Ethereum White Paper. <https://github.com/ethereum/wiki/wiki/White-Paper>. Accessed May 2017, 2017.
- [64] THE LINUX-SGX COMMUNITY. Intel(R) Software Guard Extensions for Linux OS. <https://github.com/intel/linux-sgx>.
- [65] THE RAIDEN NETWORK COMMUNITY. The raiden network. <https://raiden.network/>, retrieved October 2017, 2017.
- [66] TRAN, M., LUU, L., KANG, M. S., BENTOV, I., AND SAXENA, P. Obscuro: A bitcoin mixer using trusted execution environments. *IACR Cryptology ePrint Archive 2017* (2017), 974.
- [67] VAN BULCK, J., MINKIN, M., WEISSE, O., GENKIN, D., KASIKCI, B., PIESSENS, F., SILBERSTEIN, M., WENISCH, T. F., YAROM, Y., AND STRACKX, R. Foreshadow: Extracting the keys to the intel sgx kingdom with transient out-of-order execution. In *27th USENIX Security Symposium (USENIX Security 18)* (2018), USENIX Association.
- [68] VAN RENESSE, R., AND SCHNEIDER, F. B. Chain Replication for Supporting High Throughput and Availability. In *OSDI* (2004), vol. 4, pp. 91–104.
- [69] VISA. <https://www.visa.com/>.
- [70] WOOD, G. Ethereum: A secure decentralised generalised transaction ledger (EIP-150 revision). <http://gavwood.com/Paper.pdf>, 2016.
- [71] XU, Y., CUI, W., AND PEINADO, M. Controlled-Channel Attacks: Deterministic Side Channels for Untrusted Operating Systems. In *2015 IEEE Symposium on Security and Privacy* (May 2015), pp. 640–656.

[72] ZHANG, F., CECCHETTI, E., CROMAN, K., JUELS, A., AND SHI, E. Town crier: An authenticated data feed for smart contracts. In *Proceedings of the 2016 ACM SIGSAC conference on computer and communications security* (2016), ACM, pp. 270–282.

A Teechain Protocol Correctness

We first intuitively define the security guarantees a payment network should provide (Appendix A.1) and describe the framework we use to construct our proofs (Appendix A.2 and Appendix A.3). We then formally prove that Teechain achieves the desired security properties for both channels (Appendix A.4) and multi-hop payments (Appendix A.5).

A.1 Security Guarantees

Teechain protects the funds of all participants in the network; despite what others may do, funds cannot be stolen or double spent. We define *balance correctness* to express intuitively: at any point during an execution, any party can unilaterally reclaim the channels’ balances and unassociated deposits on the underlying blockchain, correctly reflecting all payments. Participants must be able to do so despite other’s actions.

To formalize balance correctness, we first define an execution trace σ as a time-ordered series of events, where each event represents an operation and its return value; σ_t denotes the prefix of σ until time t . For execution trace σ , user u , and time t , denote by $L_t(u)$ the balance of u in σ at time t on the blockchain, i.e., the sum of all the funds u has access to on the blockchain. In particular, $L_0(u)$ is the initial balance of u in σ . Denote by $paid_t(u)$ the accumulated sum of all payments made by u in σ_t using Teechain channels; and by $rcvd_t(u)$ the accumulated sum of payments received by u in σ_t . We thus define the *perceived balance* of u in σ at time t as $perceivedBal_t(u) = L_0(u) + rcvd_t(u) - paid_t(u)$. We therefore define *balance correctness* as:

Definition A.1 (Balance Correctness). *A protocol satisfies balance correctness if for any prefix σ_t , any well-behaved user u can unilaterally perform a series of operations, possibly interleaved with operations of other users, that will complete at finite time $t' \geq t$, after which at any time $t'' \geq t' : L_{t''}(u) \geq perceivedBal_{t'}(u)$.*

A well-behaved user, is one that faithfully follows the Teechain protocol, stores private keys used to communicate with the ledger securely, and does not leak them to other users in the system.

A.2 Ideal Functionalities and Simulation Based Security

Simulation Based Proofs in the Universal-Composability Framework. Our formal proof for Teechain’s channel protocol is based on the simulation based security framework

Universal Composability (UC) [11], which is a general purpose framework for modeling and constructing secure protocols. The model is based on a system of interactive Turing machines (ITMs), which are described based upon how they behave when receiving messages from other ITMs.

The UC framework includes several ITMs: an environment \mathcal{E} , which represents the external world. The environment chooses the inputs given to each party in the system, and observes the outputs. The framework also includes honest parties which follow the protocol, and a byzantine adversary \mathcal{A} , that can corrupt users at will. Our model deals with an adaptive adversary, i.e., once a user is corrupted by \mathcal{A} , it cannot be uncorrupted again until the end of the execution. We only define the security guarantees of honest users who follow the Teechain protocol.

The model also includes ideal functionalities, which act as idealized third parties, and implement some target specifications. We describe the behavior of such ideal functionalities based on an exposed API. This API exhibits the desired properties of the protocol. Ideal functionalities are also used in the real-world in order to represent network primitives and setup assumptions, and we use them to also model TEEs and the blockchain.

The proof that some protocol captures a specific property in the UC framework consists of the following stages:

1. Showing that any real-world execution is indistinguishable to the external environment \mathcal{E} from an equivalent ideal-world execution. The proof is based on describing a simulator \mathcal{S} in the ideal-world, which translates every adversary \mathcal{A} in the real-world into a simulated attacker, which is indistinguishable to the environment. We do so in hybrid steps, and in each step we prove indistinguishability to the environment from the previous hybrid step.
2. Proving that the desired property of the protocol is maintained by the ideal functionality in the ideal-world.

Since the real-world and ideal-world are indistinguishable, if an attacker breaks a security guarantee in the real-world, then it will also break in the ideal-one. Thus, to prove a security guarantee holds in the real-world, it is sufficient to show it holds in the ideal one.

Real-World Execution. The real-world Teechain channel protocol is identical to the one described in §4, except that we model the TEE and the ledger as ideal functionalities in the UC framework. This model is based on previous works that formalized the model, such as [55, 52, 5, 72, 40].

Ideal functionality \mathcal{F}_{TEE} . \mathcal{F}_{TEE} is an ideal functionality that models a TEE. This model is based on a version of the ideal functionality of Shi et al. [55]. User \mathcal{U} is a Teechain user equipped with a TEE; *prog* is some program to run in an enclave; *inp*, *outp*, *mem* are the *prog* input, output and memory tape respectively. We further let *sid* as the session identifier and *id* is the enclave identifier. λ is a security parameter,

and Σ , $KGen$ are a signature scheme and its key generation algorithm respectively. Lastly, let PK_{TEE}, SK_{TEE} be a TEE’s public-key and secret-key generated on the TEE’s initialization.

An enclave is an isolated software container loaded with some program, in our case the Teechain protocol. \mathcal{F}_{TEE} abstracts an enclave as a third party trusted for execution, confidentiality and authenticity, with respect to any user that is part of the system, and in particular \mathcal{U} that owns the TEE.

We now describe the API of \mathcal{F}_{TEE} . When initialized, \mathcal{F}_{TEE} generates a public secret key pair, and publicizes the public key, i.e., other users or TEEs can verify messages signed by other \mathcal{F}_{TEE} . This corresponds to an attestation service provided in the real-world execution. In addition, \mathcal{F}_{TEE} includes two calls, one for the installation of a new program $prog$, and the other one is a resume call for $prog$ with some input.

The full API of \mathcal{F}_{TEE} is:

Algorithm 4: \mathcal{F}_{TEE} ’s API

Input: $(PK_{TEE}, SK_{TEE}) \leftarrow KGen(1^\lambda)$

```

1 on receive  $(sid, idx, install, inp)$  from  $\mathcal{U}_i$ :
2   if  $(idx, \mathcal{U}_i, -, -)$  is not stored then
3     | store  $(idx, \mathcal{U}_i, prog, inp)$ 
4   else
5     | return
6   end
7 on receive  $(sid, idx, resume, inp)$  from  $\mathcal{U}_i$ :
8   if  $(idx, \mathcal{U}_i, prog, mem)$  is stored then
9     |  $outp, mem \leftarrow prog(inp, mem)$ 
10    | store  $(idx, \mathcal{U}_i, prog, mem)$ 
11    |  $\bar{\sigma} \leftarrow \Sigma.Sign(SK_{TEE}, (prog, outp))$ 
12    | return  $(sid, idx, outp, \bar{\sigma})$  to  $\mathcal{U}_i$ 
13  else
14  | return  $\perp$ 
15  end

```

\mathcal{F}_{TEE} is a *setup assumption* [11] that models the functionality offered by real-world TEEs, and in particular Intel’s SGX. Due to this, \mathcal{F}_{TEE} uses a ”real” signature scheme Σ , rather than an ideal version of it [12]. We assume that the signature scheme Σ used by \mathcal{F}_{TEE} is unforgeable under chosen attacks, and that all parties \mathcal{U}_i know PK_{TEE} of all the other TEEs at the start of the execution. We note that in order to deal with real-world SGX vulnerabilities, we use different methods to mitigate such attacks (see §7.1).

Each user \mathcal{U} is identified by unique id (simply denoted by \mathcal{U} , or Alice and Bob), and a session id sid , obtained from the environment \mathcal{E} [12]. Parties send messages to each other via authenticated channels, and the adversary \mathcal{A} observes all messages sent over the network. We use the standard ”delayed messages” terminology [12]: when a message msg is sent between users, msg is first sent to \mathcal{A} (the simulator \mathcal{S}), and forwarded to the intended user \mathcal{U} , after the acknowledgment by \mathcal{S} . Furthermore, \mathcal{S} can delay messages between parties (i.e., asynchronous network), but eventually delivers them.

Note that \mathcal{F}_{TEE} is a local ideal functionality: a user \mathcal{U} can talk to its \mathcal{F}_{TEE} without the messages being leaked to \mathcal{A} .

However, when \mathcal{A} corrupts a user it gets full access to the user’s software and hardware. \mathcal{A} can fully observe all the calls made to \mathcal{F}_{TEE} , but cannot tamper with the hardware’s confidentiality, integrity and authenticity guarantees.

Ideal functionality \mathcal{F}_{Ledger} . An ideal functionality that represents the ledger, i.e., the underlying blockchain. It maintains a single list, B , that represents the balances of all the users in the system. Each entry has a public key PK and any instruction to edit an entry requires the message to be signed by the corresponding private key, SK . Entries in B are in the form of $(PK, amount)$, where $amount$ is the current balance associated with the public key.

At the beginning of the execution, i.e. at $t = 0$, B contains initial entries with balances for the different public keys in the system. Also, some of the users also have the corresponding secret keys matching to the above public keys. \mathcal{F}_{Ledger} exposes two types of API calls, one is designed to transfer money from one entry in B to another, and one is designed to query \mathcal{F}_{Ledger} on existing entries.

Algorithm 5: \mathcal{F}_{Ledger} ’s API

Input: The initial balances of all the public keys are stored in B

```

1 on receive  $(transfer, PK_u, amount, \bar{\sigma}, PK_v)$  from  $u$ :
2   if  $\Sigma.verify(PK_u, \bar{\sigma}) \wedge \exists bal : B(PK_u) = bal \wedge bal \geq amount$  then
3     |  $B(PK_v) \leftarrow B(PK_v) + amount$ 
4     |  $B(PK_u) \leftarrow B(PK_u) - amount$ 
5   else
6   | return  $\perp$ 
7   end
8 on receive  $(getLedgerBalance, PK_u)$ 
9   if  $\exists bal : B(PK_u) = bal$  then
10  | return  $bal$ 
11  else
12  | return  $\perp$ 
13  end

```

We model the real-world execution of Teechain in the $(\mathcal{F}_{TEE}, \mathcal{F}_{Ledger})$ hybrid-model.

We are now ready to formally define balance correctness and perceived balance of any user using Teechain.

Ideal-World Model. We define the ideal functionality $\mathcal{F}_{Teechain}$ which captures Teechain’s protocol. $\mathcal{F}_{Teechain}$ is defined by an internal state of its internal variables, and by an API, which users can invoke. An invocation of an API call *call* by user u with arguments $(arg1, arg2, \dots)$ is denoted by: $call_u(arg1, arg2, \dots)$.

The internal variables $\mathcal{F}_{Teechain}$ maintains are described in Fig. 8, a description of each call is described in Fig. 9, and the complete algorithm is described in Alg. 6.

A.3 Indistinguishability of the real-world and ideal-world

We now move to show that the real-world execution is indistinguishable to the external environment from the ideal-world one.

$\mathcal{F}_{Teechain}$ maintains the following internal variables:

- L** Set of funds for the users using $\mathcal{F}_{Teechain}$. L captures the same functionality as \mathcal{F}_{Ledger} in the real-world.
Entries are in the form of $(u, amount)$, where $amount$ is u 's amount on the ledger.
- C** Set of all open channels. We denote as u and v as two users who have an open channel between them, $amountU$ and $amountV$ as u 's and v 's balances on the channel, c_{id} as a unique channel identifier agreed between u and v prior to the opening, and $isSymmetric$ as a boolean variable indicating the two different states a channel between two users can be in, i.e., whether the channel is open for both users or just the channel opening initiator.
Entries in C are in the form of $(c_{id}, u, v, amountU, amountV, isSymmetric)$.
- D** Set of deposits associated with an open channel. We denote $deposit_id$ as a unique identifier given to each new deposit by $\mathcal{F}_{Teechain}$, $amount$ as the amount of the deposit, u as the user who added the deposit, c_{id} as the channel identifier the deposit is associated to (or \perp if the deposit is not associated with any channel), and $isSymmetric$ as a boolean variable indicating if the deposit is associated to a channel, and both users are aware of this association.
Entries in D are in the form of $(deposit_id, amount, u, c_{id}, isSymmetric)$.

PendingDeposits This is a set of deposits in the process of dissociation from a channel, i.e., a user u who initiated a deposit dissociation and the dissociation is not approved yet by the other party of the channel.

Entries in *PendingDeposits*: are in the format of $(deposit_id, u, isSymmetric)$.

PendingPayments Set of pending payments, i.e., if user u sent a payment to v , and v did not accept the payment yet.

Entries in *PendingPayments*: are in the form of $(c_{id}, v, amount)$. c_{id} is the channel id where the payment with amount $amount$ is pending.

PendingChannels Set of channels in the process of being settled. In order to fully settle a channel both of its users need to settle it separately. If only one of the users settled the channel and other user did not, then this set will reflect it.

Entries in *PendingChannels*: are in the form of (c_{id}, v) , were c_{id} is the channel identifier and v is the party that did not settle the channel yet.

PendingLedgerPayments Set of pending payments waiting to be added to the ledger L .

Entries in *PendingLedgerPayments* are in the form of $(ledger_payment_id, u, amount)$, where $ledger_payment_id$ is a unique id of the payment given by $\mathcal{F}_{Teechain}$, u is the recipient of the payment of amount $amount$.

Figure 8: $\mathcal{F}_{Teechain}$'s Internal Variables

Lemma 1. *The Teechain channel protocol in the $(\mathcal{F}_{TEE}, \mathcal{F}_{Ledger})$ hybrid model UC-realizes the ideal functionality $\mathcal{F}_{Teechain}$.*

Proof. Let \mathcal{A} be an adversary against the Teechain protocol. We construct an ideal-world adversary (the simulator) \mathcal{S} , such that any environment \mathcal{E} cannot distinguish between interacting with the adversary \mathcal{A} and the Teechain protocol or with the simulator \mathcal{S} and the ideal functionality $\mathcal{F}_{Teechain}$.

We do so by a series of hybrid steps starting at the real-world execution of the protocol in the $(\mathcal{F}_{TEE}, \mathcal{F}_{Ledger})$ hybrid- H_0 , and eventually reaching the ideal world. At each step we prove indistinguishability.

- **Hybrid H_0** is the real-world execution in the $(\mathcal{F}_{TEE}, \mathcal{F}_{Ledger})$ hybrid model.
- **Hybrid H_1** behaves the same as H_0 except that \mathcal{S} generates a secret-public key pair (SK, PK) for the signing scheme Σ and publishes the public key PK. When \mathcal{A} wants to communicate with its \mathcal{F}_{TEE} , \mathcal{S} faithfully emulates \mathcal{F}_{TEE} 's behavior, and records \mathcal{A} 's messages.

As \mathcal{S} 's simulation of the real-world protocol is done perfectly, the environment \mathcal{E} cannot distinguish between H_0 (the real-world execution) and H_1 .

- **Hybrid H_2** behaves the same as H_1 except for the following difference: whenever \mathcal{A} wants to communicate with \mathcal{F}_{Ledger} , \mathcal{S} faithfully emulates \mathcal{F}_{Ledger} 's behavior for \mathcal{A} . As \mathcal{A} 's view in H_2 are perfectly emulated for him when interacting with the ledger, no environment \mathcal{E} can distinguish between H_2 and H_1 .

- **Hybrid H_3** behaves the same as H_2 except for the following difference: If \mathcal{A} invoked its \mathcal{F}_{TEE} with a correct install message with program $prog$, then for every correct resume message \mathcal{S} records the tuple (msg, σ) from \mathcal{F}_{TEE} , where msg is the output of running $prog$ in \mathcal{F}_{TEE} , and σ is the signature generated inside the \mathcal{F}_{TEE} , using the SK generated in H_1 .

Let Ω denote all such possible tuples. If $(msg, \sigma) \notin \Omega$ then \mathcal{S} aborts, otherwise, \mathcal{S} delivers the message to Bob (the party in the protocol that is not controlled by \mathcal{A}).

We can argue that H_2 is indistinguishable from H_1 by reducing the problem to the EU-CMA of the signing scheme. If \mathcal{A} does not send one of the correct tuples to the other party, then the other party's attestation (verification mechanism) will fail (but with negligible probability). Otherwise, \mathcal{E} and \mathcal{A} can be leveraged to construct an adversary that succeeds in a signature forgery.

<p>The following calls are for user interaction with the ledger:</p> <p>getLedgerBalance Upon receiving <code>getLedgerBalance_v(u)</code> from any user v in the system, $\mathcal{F}_{Teechain}$ returns the current entry in L indicating u's balance on the ledger.</p> <p>acceptLedgerPayment Upon receiving this call from a user u in the system, $\mathcal{F}_{Teechain}$ checks if u has a pending payment waiting to be reflected on the ledger L. If so, $\mathcal{F}_{Teechain}$ changes L to reflect the payment.</p> <p>The following calls capture the unilateral deposit handling of users:</p> <p>addDeposit When receiving this call $\mathcal{F}_{Teechain}$ adds a new deposit for user u.</p> <p>removeDeposit User u can call this function to remove an unassociated deposit from the system and add the deposit's amount back on the ledger.</p> <p>The last set of calls captures the logic of user interaction with other users and handle channels in the system:</p> <p>openChannel u invokes this call in order to initiate a channel opening between her and another user in the system.</p> <p>acceptChannelOpen v can invoke this call to complete the channel opening process. This call can be invoked by the v after <code>openChannel</code> is invoked.</p> <p>associateDeposit u can invoke this call in order to start the process of associating a deposit with a specific channel.</p>	<p>acceptAssociateDeposit v invokes this call to complete the process of associating the deposit $deposit_id$. In the real-world execution v needs to make sure at this stage that the deposit is on the ledger.</p> <p>dissociateDeposit Invoked by u to start dissociating deposit $deposit_id$ from a channel it is associated to.</p> <p>acceptDissociate The second phase of dissociating a deposit from a channel, indicating that the other party in the channel accepted the dissociation.</p> <p>ackDissociate Completes the dissociation of a deposit from a channel. After the call ends successfully the deposit can be removed or associated again with another channel by u.</p> <p>pay User u invokes this function to pay $amount$ on channel c_{id} to user v. When the call ends, $\mathcal{F}_{Teechain}$ returns to u a payment id $pending_payment_id$.</p> <p>receivePayment v invokes this function to accept a payment with payment id $pending_payment_id$ made by another user on a channel. After the call ends, v's balance on the channel is increased by $amount$.</p> <p>settleChannel u invokes this call to settle channel c_{id}, i.e., receive his current balance from the channel on the ledger. When invoked, $\mathcal{F}_{Teechain}$ generates a pending payment $pending_payment_id$ which reflects u's balance on the channel and returns it to u.</p>
---	--

Figure 9: $\mathcal{F}_{Teechain}$'s Calls

- **Hybrid H_4** is the same as H_3 except that for the following difference: Whenever \mathcal{A} delivers a signed message (by himself or from his \mathcal{F}_{TEE}) to other users in the system signed by a secret key of Teechain's protocol, \mathcal{S} behaves as in H_3 , i.e., \mathcal{S} records the tuple (msg, σ) , and as in H_4 , \mathcal{S} aborts if msg is not signed correctly by the corresponding secret key.

H_4 is indistinguishable from H_3 for the same reasons H_3 is indistinguishable from H_2 , i.e., otherwise \mathcal{E} and \mathcal{A} will be able to construct an adversary that can succeed in signature forgery.

- **Hybrid H_5** is the ideal world execution, i.e., we map the calls in the simulated real-world to calls of \mathcal{S} to $\mathcal{F}_{Teechain}$.
 - **newPayChannel** Whenever a user sends `newPayChannel` to \mathcal{F}_{TEE} to create a new channel, \mathcal{S} sends a `openChannel` message to $\mathcal{F}_{Teechain}$ in the ideal world.
 - **newChannelAck** Whenever `newChannelAck` is delivered to the recipient in the real-world, \mathcal{S} invokes `acceptChannelOpen` to $\mathcal{F}_{Teechain}$.
 - **approvedDeposit** Whenever a user invokes his \mathcal{F}_{TEE} with `approvedDeposit` after correctly trans-

ferring money on the ledger by invoking `transfer` to \mathcal{F}_{Ledger} , \mathcal{S} invokes $\mathcal{F}_{Teechain}$ with `addDeposit`, and records the returned $deposit_id$.

- **releaseDeposit** Whenever a user invokes `releaseDeposit` to his \mathcal{F}_{TEE} , \mathcal{S} calls `removeDeposit` to $\mathcal{F}_{Teechain}$ with the corresponding $pending_payment_id$, and when the user calls `transfer` to \mathcal{F}_{Ledger} in order to place the tx on the ledger, \mathcal{S} calls `acceptLedgerPayment` with the corresponding $pending_payment_id$.
- **associateMyDeposit** Whenever a user sends `associateMyDeposit` to another user in the system, \mathcal{S} sends `associateDeposit` to $\mathcal{F}_{Teechain}$ on that user's behalf.
- **associateTheirDeposit** Whenever a user invokes \mathcal{F}_{TEE} with `associateTheirDeposit`, the simulator \mathcal{S} calls `acceptAssociateDeposit` with the corresponding deposit id $deposit_id$.
- **dissociateDeposit** When a user correctly invokes his \mathcal{F}_{TEE} with `dissociateDeposit`, \mathcal{S} calls `dissociateDeposit`.
- **dissociatedDeposit** When a user passes to his \mathcal{F}_{TEE} `dissociatedDeposit` message, \mathcal{S} invokes

Algorithm 6: $\mathcal{F}_{Techain}$'s API

```

1   $\forall u : L(u) \leftarrow \perp$ 
2   $\forall c_{id} : C(c_{id}) \leftarrow \perp$ 
3   $\forall deposit\_id : D(deposit\_id) \leftarrow \perp$ 
4   $\forall deposit\_id : PendingDeposits(deposit\_id) \leftarrow \perp$ 
5   $\forall pending\_payment\_id :$ 
    $PendingPayments(pending\_payment\_id) \leftarrow \perp$ 
6   $\forall c_{id} : PendingChannels(c_{id}) \leftarrow \perp$ 
7   $\forall ledger\_payment\_id :$ 
    $PendingLedgerPayments(ledger\_payment\_id) \leftarrow \perp$ 
8  on getLedgerBalancev(u) /* The Ledger is public,
   any user can get the balance of any other user in the
   system */
9  if  $L(u) \neq \perp$  then
10 | return (success, L(u))
11 else
12 | return (fail)
13 on acceptLedgerPaymentu(ledger\_payment\_id)
14 if  $\exists amount :$ 
    $PendingLedgerPayments(ledger\_payment\_id) =$ 
   (u, amount) then
15 |  $L(u) \leftarrow L(u) + amount$ 
16 |  $PendingLedgerPayments(ledger\_payment\_id) \leftarrow \perp$ 
17 | return (success)
18 else
19 | return (fail)
20 on addDepositu(amount)
21 if  $L(u) \geq amount$  /* If u has enough money on the
   ledger to create the deposit */
22 then
23 |  $deposit\_id \leftarrow textitdeposit\_counter$ 
24 |  $deposit\_counter \leftarrow deposit\_counter + 1$ 
25 |  $D(deposit\_id) \leftarrow (amount, u, \perp, \perp)$ 
26 |  $L(u) \leftarrow L(u) - amount$ 
27 | return (success, deposit\_id)
28 else
29 | return (fail)
30 on removeDepositu(deposit\_id)
31 if  $\exists amount, isSymmetric : D(deposit\_id) =$ 
   (amount, u,  $\perp$ , isSymmetric) /* deposit entry is not
   associated with any channel */
32 then
33 |  $PendingLedgerPayments(ledger\_payment\_id) \leftarrow$ 
   (u, amount)
34 |  $ledger\_payment\_id \leftarrow ledger\_payment\_id + 1$ 
35 |  $D(deposit\_id) \leftarrow \perp$ 
36 | return (success, ledger\_payment\_id)
37 else
38 | return (fail)
39 on openChannelu(cid, v)
40 if  $C(c_{id}) = \perp$  /* there is not a channel entry with cid */
41 then
42 |  $C(c_{id}) \leftarrow (u, v, 0, 0, \perp)$  /* initialize an entry for the
   channel with capacity 0 for both sides */
43 | return (success)
44 else
45 | return (fail)
46 on acceptChannelOpenv(cid)
47 if  $\exists amountU, amountV : C(c_{id}) =$ 
   (u, v, amountU, amountV,  $\perp$ ) then
48 |  $C(c_{id}) \leftarrow (u, v, amountU, amountV, T)$ 
49 | return (success)
50 else
51 | return (fail)
52 on associateDepositu(cid, deposit\_id)
53 if  $\exists amount : D(deposit\_id) = (amount, u, \perp, \perp) \wedge$ 
    $\exists x, y, amountX, amountY, isSymmetric : C(c_{id}) =$ 
   (x, y, amountX, amountY, isSymmetric)  $\wedge (x =$ 
   u  $\vee y = u)$  then
54 if  $y = u \wedge isSymmetric = \perp$  /* the channel is not
   accepted by both parties */ then
55 | return (fail)
56 else
57 |  $D(deposit\_id) \leftarrow (amount, u, c_{id}, \perp)$  /* assign the
   deposit to channel cid */ if  $x = u$  then
58 |  $C(c_{id}) \leftarrow$ 
   (x, y, amountX + amount, amountY, isSymmetric)
59 else
60 |  $C(c_{id}) \leftarrow$ 
   (x, y, amountX, amountY + amount, isSymmetric)
61 return (success)
62 else
63 | return (fail)
64 on acceptAssociateDepositu(cid, deposit\_id)
65 if  $\exists amount : D(deposit\_id) = (amount, u, c_{id}, \perp)$ 
66 then
67 |  $D(deposit\_id) \leftarrow (amount, u, c_{id}, T)$ 
68 | return (success)
69 else
70 | return (fail)
71 on dissociateDepositu(deposit\_id)
72 if  $\exists amount, c_{id}, isSymmetric : D(deposit\_id) =$ 
   (amount, u, cid, isSymmetric)  $\wedge$ 
    $\exists v, amountU, amountV, isSymmetric : C(c_{id}) =$ 
   (cid, u, v, amountU, amountV, isSymmetric)  $\wedge$ 
   amount  $\leq$  amountU /* The deposit is accepted by
   both sides, and u has enough capacity in the
   channel to dissociate */
73 then
74 |  $C(c_{id}) \leftarrow$ 
   (cid, u, v, amountU - amount, amountV, isSymmetric)
   /* deduct the deposit's amount from u's
   capacity in the channel */
75 |  $PendingDeposits(deposit\_id) \leftarrow (u, \perp)$  /* entry in-
   dicating deposit\_id is about to be dissociated */
76 | return (success)
77 else
78 | return (fail)
79 on acceptDissociatev(deposit\_id)
80 if  $\exists u$  s.t.  $PendingDeposits(deposit\_id) = (u, \perp)$  then
81 |  $PendingDeposits(deposit\_id) \leftarrow (u, T)$ 
82 | return (success)
83 else
84 | return (fail)
85 on ackDissociateu(deposit\_id)
86 if  $PendingDeposits(deposit\_id) = (u, T)$  then
87 |  $PendingDeposits(deposit\_id) \leftarrow \perp$ 
88 |  $D(deposit\_id) \leftarrow (deposit\_id, amount, u, \perp, \perp)$ 
   //change third argument of the entry to indicate
   the dissociation is completed
89 | return (success)
90 else
91 | return (fail)
92 on payv(cid, amount)
93 if  $\exists x, y, amountX, amountY, isSymmetric : C(c_{id}) =$ 
   (x, y, amountX, amountY, isSymmetric)  $\wedge$ 
   ((isSymmetric = T)  $\vee$  (isSymmetric =  $\perp \wedge x = u$ ))
94 then
95 | if  $x = u \wedge amount \leq amountX$  then
96 |  $C(c_{id}) \leftarrow$ 
   (x, y, amountX - amount, amountY, isSymmetric)
97 |  $PendingPayments(pending\_payment\_id) \leftarrow$ 
   (y, cid, amount)
98 | if  $y = u \wedge amount \leq amountY$  then
99 |  $C(c_{id}) \leftarrow$ 
   (x, y, amountX, amountY - amount, isSymmetric)
100 |  $PendingPayments(pending\_payment\_id) \leftarrow$ 
   (x, cid, amount)
101 |  $pending\_payment\_id \leftarrow pending\_payment\_id + 1$ 
102 | return (success, pending\_payment\_id)
103 else
104 | return (fail)
105 on receivePaymentv(pending\_payment\_id)
106 if  $\exists c_{id}, amount :$ 
    $PendingPayments(pending\_payment\_id) =$ 
   (v, cid, amount) then
107 |  $C(c_{id}) \leftarrow (u, v, amountV + amount, isSymmetric)$ 
108 | return (success)
109 |  $PendingPayments(pending\_payment\_id) \leftarrow \perp$ 
110 else
111 | return (fail)
112 on settleChannelu(cid)
113 if  $\exists v, amountU, amountV, isSymmetric : C(c_{id}) =$ 
   (u, v, amountU, amountV, isSymmetric) then
114 |  $pendingDeposits \leftarrow \{deposit\_id\}$ 
115 |  $PendingDeposits(deposit\_id) = (u, \perp) \vee (u, T)$ 
116 |  $pendingDepositsSum \leftarrow \sum_{x \in pendingDeposits} x$  /*
   Need to remove all the deposits that their
   dissociation is not completed */
117 |  $PendingLedgerPayments(ledger\_payment\_id) \leftarrow$ 
   (u, amountU + pendingDepositsSum)
118 |  $ledger\_payment\_id \leftarrow ledger\_payment\_id + 1$ 
119 | foreach (deposit\_id  $\in$  pendingDeposits):
120 |  $PendingDeposits(deposit\_id) = \perp$ 
121 | foreach (deposit\_id  $\in$  pendingDeposits):
122 |  $D(deposit\_id) \leftarrow \perp$ 
123 |  $C(c_{id}) \leftarrow (u, v, 0, amountV, isSymmetric)$ 
124 | if  $PendingChannels(c_{id}) = \perp$  /* If this is the first
   settle message */
125 | then
126 |  $PendingChannels(c_{id}) \leftarrow v$ 
127 | else
128 |  $deposits \leftarrow$ 
   {deposit\_id |  $\exists amount, isSymmetric, x :$ 
    $D(deposit\_id) = (amount, x, c_{id}, isSymmetric)$ }
129 | foreach (deposit\_id  $\in$  deposits):
130 |  $D(deposit\_id) \leftarrow \perp$  /* remove all the deposits
   associated with the channel */
131 |  $C(c_{id}) \leftarrow \perp$ 
132 |  $PendingChannels(c_{id}) \leftarrow \perp$ 
133 | return (success, ledger\_payment\_id)
134 else
135 | return (fail)

```

dissociateDeposit to $\mathcal{F}_{Techain}$.

- **dissociatedDepositAck** When a user invokes his \mathcal{F}_{TEE} with the message dissociatedDepositAck, \mathcal{S} invokes ackDissociate in the ideal world.
- **pay** When a user invokes pay to \mathcal{F}_{TEE} , \mathcal{S} invokes pay

to $\mathcal{F}_{Techain}$.

- **paid** Whenever a user passes paid to his \mathcal{F}_{TEE} , then \mathcal{S} calls receivePayment.
- **settle** Whenever a user invokes settle to his \mathcal{F}_{TEE} , \mathcal{S} invokes settleChannel commands on behalf of

the user of the channel, i.e., for a channel between u and v them \mathcal{S} will invoke `settleChannelu` and `settleChannelv` with the channel id c_{id} .

In H_4 \mathcal{S} can faithfully interact with $\mathcal{F}_{Teechain}$, while faithfully emulating \mathcal{A} 's view of the real-world. \mathcal{S} can then output to \mathcal{E} exactly \mathcal{A} 's output in the real-world. Thus, there does not exist any environment \mathcal{E} that can distinguish between interaction with \mathcal{A} and the Teechain channel protocol, from interaction with \mathcal{S} and $\mathcal{F}_{Teechain}$.

□

Next, we define balance correctness in the ideal-world, and prove that $\mathcal{F}_{Teechain}$ captures it.

A.4 Balance Correctness in the Ideal-World

We proved that for any environment \mathcal{E} the ideal-world and the real-world executions are indistinguishable. Therefore, we can define the security interest of a payment channel in the ideal-world, and prove that the ideal-world execution achieves this desired property. Since both the ideal and the real world are indistinguishable to any environment, then both the definition of balance correctness, and the proof that it holds in the ideal-world will also hold in the real-world, thus concluding the proof.

Notations and Definitions. We define our security goal to be *balance correctness*. Intuitively, this means that at any point in time, an honest user u can choose to settle a channel c_{id} with another user v , even if v is corrupt or crashes arbitrarily, and receive her balance on the ledger without the ability of v or any other user w to affect the outcome.

To formally discuss *balance correctness* we first define a few notations and definitions:

An *execution* $\sigma = (ev_1, ev_2, \dots, ev_n) = ((op_1, ret_1), (op_2, ret_2), \dots, (op_n, ret_n))$ is a series of events ev , each consists of a call op to $\mathcal{F}_{Teechain}$ and its return value from $\mathcal{F}_{Teechain}$, ret . Each event might also result in the change of the state, i.e., the internal variables maintained by $\mathcal{F}_{Teechain}$.

$L_t(u)$ is the balance on the Ledger for user u at time t , i.e., if any user v calls `getLedgerBalancev(u)` at time t , then $L_t(u)$ is the returned value.

The initial time 0 is a time in an execution in the ideal-world prior to any calls to $\mathcal{F}_{Teechain}$, with some initial value on the Ledger for the users in the run, e.g. users u, v, w with some initial values $L_0(u), L_0(v), L_0(w)$ respectively. σ_t is the prefix of the execution σ from time 0 to t .

We denote $payments_t(u)$ be the set of all the amounts of successful `pay` calls to $\mathcal{F}_{Teechain}$ from u that returned *success*

during σ_t :

$$\begin{aligned} payments_t(u) &= \{amount\} \\ \exists i, c_{id}, v, amount, pending_payment_id : \\ ev_i \in \sigma_t, op_i &= \text{pay}_u(c_{id}, v, amount), \\ ret_i &= (success, pending_payment_id) \end{aligned}$$

Let $paid_t(u)$ be the sum of all payments in $payments_t(u)$, i.e.,

$$paid_t(u) = \sum_{amount \in payments_t(u)} amount$$

We denote $receivedPayments_t(u)$ to be a set of all the amounts of successful `receivePayment` calls to $\mathcal{F}_{Teechain}$ from u that returned *success* during σ_t :

$$\begin{aligned} receivedPayments_t(u) &= \{amount\} \\ \exists i, pending_payment_id, c_{id}, amount : \\ ev_i \in \sigma_t, op_i &= \text{receivePayment}_u(pending_payment_id), \\ \exists j < i, amount : ev_j \in \sigma_t, op_j &= \text{pay}_u(c_{id}, amount), \\ ret_j &= (success, pending_payment_id) \end{aligned}$$

Let $receivedPayments_t(u)$ be the sum of all such received payments in $receivedPayments_t(u)$, i.e.

$$rcvd_t(u) = \sum_{amount \in receivedPayments_t(u)} amount$$

We are now ready to define the *perceived balance* in the ideal-world of user u .

Definition A.2 (Perceived Balance in the Ideal-World). *The perceived balance of user u at time t is defined as*

$$perceivedBal_t(u) = L_0(u) + rcvd_t(u) - paid_t(u)$$

We are now ready to formally define balance correctness.

Definition A.3 (Balance Correctness). *We say an algorithm satisfies balance correctness if for any prefix σ_t for $t \geq 0$, and for any well-behaved user u in the system, u can preform a series of operations, possibly interleaved with operations of other users, that will be completed in a finite time t' , after which at any time $t'' \geq t'$: $L_{t''}(u) \geq perceivedBal_{t'}(u)$.*

A user u is honest or well-behaved if she follows the series of operations of the algorithm. We note that definitions definition A.3 and definition A.1 are equal to the environment \mathcal{E} as the ideal-world and the real-world are indistinguishable to it.

Theorem A.1. [*Balance Correctness Theorem*] *The ideal functionality $\mathcal{F}_{Teechain}$ achieves balance correctness.*

In order to show that $\mathcal{F}_{Teechain}$ achieves balance correctness we need to show an algorithm, i.e., a series of operations that an honest user u has to preform in order to receive her perceived balance $perceivedBal_t(u)$.

We define the following sets, based on the internal variables of $\mathcal{F}_{Teechain}$:

1. All the deposit ids in D that are not currently associated with any channel at time t :

$$\begin{aligned} \text{innerDeposits}_t(u) &= \{ \text{deposit_id} \mid \\ &\quad \exists \text{deposit_id}, \text{isSymmetric} : \\ &\quad D(\text{deposit_id}) = (\text{amount}, u, \perp, \text{isSymmetric}) \} \end{aligned}$$

2. All the channel ids that have not been settled yet until time t . i.e.:

$$\begin{aligned} \text{innerChannels}_t(u) &= \\ &= \{ c_{id} \mid \exists c_{id}, v, \text{amount}V, \text{isSymmetric} : \\ &\quad C(c_{id}) = (u, v, \text{amount}U, \text{amount}V, \text{isSymmetric}) \\ &\quad \vee C(c_{id}) = (v, u, \text{amount}V, \text{amount}U, \text{isSymmetric}), \\ &\quad \text{PendingChannels}(c_{id}) \neq u \} \end{aligned}$$

3. All the ledger payment ids ledger_payment_id that are associated with u and have not been placed on the ledger yet:

$$\begin{aligned} \text{innerPendingLedgerPayment}_t(u) &= \\ &= \{ \text{ledger_payment_id} \mid \exists \text{ledger_payment_id} : \\ &\quad \text{PendingLedgerPayments}(\text{ledger_payment_id}) = \\ &\quad (u, \text{amount}) \} \end{aligned}$$

In order for u to receive her perceived balance $\text{perceivedBal}_t(u)$, we describe an algorithm, i.e., a series of calls to $\mathcal{F}_{\text{Teechain}}$.

1. u places a set of **remove** operations for each $\text{deposit_id} \in \text{innerDeposits}_t(u)$:

$$\begin{aligned} OPS_1 &= \{ \text{removeDeposit}_u(\text{deposit_id}) \mid \\ &\quad \text{deposit_id} \in \text{innerDeposits}_t(u) \} \end{aligned}$$

Lemma 2. *If u places the calls to $\mathcal{F}_{\text{Teechain}}$ described in OPS_1 , then the return value of each call is success with some ledger payment id value ledger_payment_id .*

Proof. The if statement in the **removeDeposit** algorithm (Alg. 6, Line 31) will be true for any deposit id $\text{deposit_id} \in \text{innerDeposits}_t(u)$, which means that $\mathcal{F}_{\text{Teechain}}$ will create a new ledger payment id ledger_payment_id and return *success* with ledger_payment_id (Line 35). \square

Lemma 3. *User u has all the deposit ids $\text{deposit_id} \in \text{innerDeposits}_t(u)$, such that she has the ability to invoke all the calls in OPS_1 .*

Proof. OPS_1 is defined on a set of deposit ids deposit_id such that there exists the entry $D(\text{deposit_id}) = (\text{amount}, u, \perp, \text{isSymmetric})$. The only option for such an entry to be generated, is if during σ_t $\text{addDeposit}_u(\text{amount})$ was invoked by u . When

the call returns successfully, $\mathcal{F}_{\text{Teechain}}$ returns $(\text{success}, \text{ledger_payment_id})$ to u . Thus, at time t , u already has all the deposit ids she needs in order to invoke the **removeDeposit** calls in OPS_1 . \square

2. u places a set of **settle** operations for each channel id $c_{id} \in \text{innerChannels}_t(u)$:

$$OPS_2 = \{ \text{settle}_u(c_{id}) \mid c_{id} \in \text{innerChannels}_t(u) \}$$

Lemma 4. *If u places the calls to $\mathcal{F}_{\text{Teechain}}$ described in OPS_2 , then the return value of each call is success with some ledger payment id value ledger_payment_id .*

Proof. The if statement of the **settleChannel** algorithm (Alg. 6, Line 108) will be true for any c_{id} in $\text{innerChannels}_t(u)$, thus $\mathcal{F}_{\text{Teechain}}$ will return *success* with a ledger id ledger_payment_id (Line 123). \square

Lemma 5. *User u has all the channel ids $c_{id} \in \text{innerChannels}_t(u)$ such that she can invoke all the **settleChannel** calls in OPS_2 .*

Proof. OPS_2 is defined as **settleChannel** calls for channel ids c_{id} such that $C(c_{id})$ exists with user u . The only option for such an entry to be generated is if u invoked $\text{openChannel}_u(c_{id})$ during σ_t or invoked $\text{acceptChannelOpen}_u(c_{id})$. Thus, at time t , u has all the channels ids she needs in order to invoke the **settleChannel** calls as defined in OPS_2 . \square

We proved that if u places the calls to $\mathcal{F}_{\text{Teechain}}$ described in OPS_1 and in OPS_2 , then the return value of all these calls is $(\text{success}, \text{ledger_payment_id})$.

We denote by t_1 the time in which all the calls in $OPS_1 \cup OPS_2$ return successfully.

Let us define a set of the return values for each operation in $OPS_1 \cup OPS_2$ at t_1 :

$$\begin{aligned} RET &= \{ \text{ledger_payment_id} \mid \\ &\quad \exists i : \text{ev}_i = (op_i, \text{ret}_i) \in \sigma_{t_1}, op_i \in OPS_1 \cup OPS_2, \\ &\quad \text{ret}_i = (\text{success}, \text{ledger_payment_id}) \} \end{aligned}$$

3. u places a set of **acceptLedgerPayment** operations for each $\text{ledger_payment_id} \in RET \cup \text{innerPendingLedgerPayment}_t(u)$:

$$\begin{aligned} OPS_3 &= \{ \text{acceptLedgerPayment}_u(\text{ledger_payment_id}) \mid \\ &\quad \text{ledger_payment_id} \in RET \cup \\ &\quad \text{innerPendingLedgerPayment}_t(u) \} \end{aligned}$$

Lemma 6. *If u places the calls described in OPS_3 then $\mathcal{F}_{\text{Teechain}}$ returns success for each of them.*

Proof. All the pending payment ids of the calls described in OPS_3 are in $PendingPayments$ as proved in Lemma 2 and Lemma 4, thus when u places $acceptLedgerPayment$ with those pending $pending_payment_id$, $\mathcal{F}_{Teechain}$ will return *success*. \square

Definition A.4 (balance correctness algorithm). *The suffix for u in order to receive $perceivedBal_t(u)$ in the prefix σ_t is:*

$$OPS_u \triangleq (OPS_1, OPS_2, OPS_3)$$

We now move to show that by invoking the calls in Definition A.4, any user can receive her perceived balance, thus proving Theorem A.1.

Let $innerChannelBalance_t(u)$ be the set of all the capacities of all the open channels user u has with other users in the system at a given time t :

$$\begin{aligned} innerChannelBalance_t(u) &= \{amountU \mid \\ &\quad \exists c_{id}, v, amountV, isSymmetric : \\ &\quad (C(c_{id}) = (u, v, amountU, amountV, isSymmetric) \\ &\quad \vee C(c_{id}) = (v, u, amountV, amountU, isSymmetric)), \\ &\quad PendingChannels(c_{id}) \neq u\} \end{aligned}$$

Let $innerChannelBalanceSum_t(u)$ be the sum of all the capacities in $innerChannelBalance_t(u)$:

$$innerChannelBalanceSum_t(u) = \sum_{amount \in innerChannelBalance_t(u)} amount$$

Let $innerDepositBalance_t(u)$ be the set of the amounts of deposits that user u added and not removed, and are not associated with any channel at a given time t , i.e.:

$$\begin{aligned} innerDepositBalance_t(u) &= \{amount \mid \\ &\quad \exists deposit_id, isSymmetric : \\ &\quad D(deposit_id) = (amount, u, \perp, isSymmetric)\} \end{aligned}$$

Let $innerDepositBalanceSum_t(u)$ be the sum of all amounts in $innerDepositBalance_t(u)$:

$$innerDepositBalanceSum_t(u) = \sum_{amount \in innerDepositBalance_t(u)} amount$$

Let $innerPendingLedgerOpsSum_t(u)$ be a set of all pending ledger operations from user u at a given time t , i.e.:

$$\begin{aligned} innerPendingLedgerOpsSum_t(u) &= \\ &= \{amount \mid \exists ledger_payment_id : \\ &\quad PendingLedgerPayments(ledger_payment_id) = (u, amount)\} \end{aligned}$$

Let $innerPendingLedgerOpsSum_t(u)$ be the sum of all the amount of the ledger payment operations in $innerPendingLedgerOpsSum_t(u)$:

$$innerPendingLedgerOpsSum_t(u) = \sum_{amount \in innerPendingLedgerOpsSum_t(u)} amount$$

Let $innerPendingDeposits_t(u)$ be a set of all amounts of deposits in the process of being dissociated from a channel,

i.e., all deposits in $PendingDeposits$:

$$\begin{aligned} innerPendingDeposits_t(u) &= \\ &= \{amount \mid \exists deposit_id, c_{id}, isSymmetric : \\ &\quad PendingDeposits(deposit_id) = (u, isSymmetric), \\ &\quad D(deposit_id) = (amount, u, c_{id}, isSymmetric)\} \end{aligned}$$

Let $innerPendingDepositsSum_t(u)$ be the sum of all the amounts of pending deposits in $innerPendingDeposits_t(u)$:

$$innerPendingDepositsSum_t(u) = \sum_{amount \in innerPendingDeposits_t(u)} amount$$

Definition A.5. *Let $stateBalance_t(u)$ be the balance of u , as defined by the internal state of $\mathcal{F}_{Teechain}$ at a given time t , i.e.:*

$$\begin{aligned} stateBalance_t(u) &= L_t(u) + innerChannelBalanceSum_t(u) + \\ &\quad + innerDepositBalanceSum_t(u) + \\ &\quad + innerPendingLedgerOpsSum_t(u) + \\ &\quad + innerPendingDepositsSum_t(u) \end{aligned}$$

We begin by showing, that at any given time t the state balance of u is the same as the perceived balance as defined in Definition A.2.

Proposition 1. *At any execution σ the inner balance of u and the perceived balances are equal, i.e.:*

$$perceivedBal_t(u) = stateBalance_t(u)$$

Proof. We will prove this by induction on the execution σ .

Inductive base. In the beginning of the execution σ at $t = 0$ all the internal variables of $\mathcal{F}_{Teechain}$ are \perp , i.e., for any internal variable f of $\mathcal{F}_{Teechain}$, and for any x : $f(x) = \perp$. Thus:

$$\begin{aligned} innerChannelBalance_0(u) &= \emptyset \\ innerDepositBalance_0(u) &= \emptyset \\ innerPendingLedgerOpsSum_0(u) &= \emptyset \\ innerPendingDepositsSum_0(u) &= \emptyset \end{aligned}$$

Which means that:

$$\begin{aligned} innerChannelBalanceSum_0(u) &= 0 \\ innerDepositBalanceSum_0(u) &= 0 \\ innerPendingLedgerOpsSum_0(u) &= 0 \\ innerPendingDepositsSum_0(u) &= 0 \end{aligned}$$

And: $stateBalance_0(u) = perceivedBal_0(u)$

Inductive step. Let us assume that in step $i < t$: $stateBalance_i(u) = perceivedBal_i(u)$. We show that after the next event at step $i + 1$: $stateBalance_{i+1}(u) = perceivedBal_{i+1}(u)$.

First we note that the inner balance as defined above does not change if $\mathcal{F}_{Teechain}$ returns *fail* for any call, as the if statement in the beginning of each of its calls will cause it to return *fail* and change nothing, and in particular, not change $L_i(u)$.

We go over all the event types, each of them a result of a call to $\mathcal{F}_{Teechain}$, and show that for each of them, under the induction assumption for step i , it also holds for step $i + 1$, i.e.:

$$stateBalance_{i+1}(u) = perceivedBal_{i+1}(u)$$

- **getLedgerBalance** This algorithm does not affect any variable of $\mathcal{F}_{Teechain}$.

- **acceptLedgerPayment** This algorithm takes *amount* from *PendingLedgerPayments* at time *i* and adds it to $L_{i+1}(u)$, then it removes *PendingLedgerPayments*(*ledger_payment_id*), i.e.:

$$\begin{aligned} innerPendingLedgerOpsSum_{i+1}(u) &= \\ innerPendingLedgerOpsSum_i(u) - amount \\ L_{i+1}(u) &= L_i(u) + amount \end{aligned}$$

$$\begin{aligned} stateBalance_i(u) &= stateBalance_{i+1}(u) = \\ &= perceivedBal_i(u) = perceivedBal_{i+1}(u) \end{aligned}$$

- **addDeposit** This algorithm deducts *amount* from $L_i(u)$ and adds an entry *D*(*depositEntry*) with *amount*, i.e.:

$$\begin{aligned} innerDepositBalanceSum_{i+1}(u) &= \\ &= innerDepositBalanceSum_i(u) + amount \\ L_{i+1}(u) &= L_i(u) - amount \end{aligned}$$

$$\begin{aligned} stateBalance_i(u) &= stateBalance_{i+1}(u) = \\ &= perceivedBal_i(u) = perceivedBal_{i+1}(u) \end{aligned}$$

- **removeDeposit** This algorithm removes *D*(*deposit_id*) and adds *amount* to *PendingLedgerPayments*(*ledger_payment_id*), i.e.:

$$\begin{aligned} innerPendingLedgerOpsSum_{i+1}(u) &= \\ &= innerPendingLedgerOpsSum_i(u) + amount \end{aligned}$$

$$\begin{aligned} innerDepositBalanceSum_{i+1}(u) &= \\ &= innerDepositBalanceSum_i(u) - amount \end{aligned}$$

$$\begin{aligned} stateBalance_i(u) &= stateBalance_{i+1}(u) = \\ &= perceivedBal_i(u) = perceivedBal_{i+1}(u) \end{aligned}$$

- **openChannel** This algorithm does not affect the inner balance and therefore at step *i* + 1 the inner and perceived balances are the same as in step *i*.

- **acceptChannelOpen** This algorithm does not affect the inner balance and therefore at step *i* + 1 the inner and perceived balances are the same as in step *i*.

- **associateDeposit** This algorithm changes the third argument of *D*(*deposit_id*) to c_{id} , which logically means that the deposit *deposit_id* is now associated with channel c_{id} . By doing so, it moves *amount* from $innerDepositBalanceSum_i(u)$ to $innerChannelBalanceSum_{i+1}(u)$, i.e.:

$$\begin{aligned} innerDepositBalanceSum_{i+1}(u) &= \\ &= innerDepositBalanceSum_i(u) - amount \end{aligned}$$

$$\begin{aligned} innerChannelBalanceSum_{i+1}(u) &= \\ &= innerChannelBalanceSum_i(u) + amount \end{aligned}$$

$$\begin{aligned} stateBalance_i(u) &= stateBalance_{i+1}(u) = \\ &= perceivedBal_i(u) = perceivedBal_{i+1}(u) \end{aligned}$$

- **acceptAssociateDeposit** This algorithm does not affect the inner balance and therefore at step *i* + 1 the inner and perceived balances are the same as in step *i*.

- **dissociateDeposit** This algorithm deducts *amount* from the balance of *u* at time *i* in channel c_{id} and adds it to *PendingDeposits*(*deposit_id*) at *i* + 1, i.e.:

$$\begin{aligned} innerChannelBalanceSum_{i+1}(u) &= \\ &= innerChannelBalanceSum_i(u) - amount \end{aligned}$$

$$\begin{aligned} innerPendingDepositsSum_{i+1}(u) &= \\ &= innerPendingDepositsSum_i(u) + amount \end{aligned}$$

$$\begin{aligned} stateBalance_i(u) &= stateBalance_{i+1}(u) = \\ &= perceivedBal_i(u) = perceivedBal_{i+1}(u) \end{aligned}$$

- **acceptDissociate** This algorithm does not affect the inner balance and therefore at step *i* + 1 the inner and perceived balances are the same as in step *i*.

- **ackDissociate** This algorithm removes the entry *PendingDeposits*(*deposit_id*) and changes the third argument of *D*(*deposit_id*) to \perp , which logically means that the deposit is not associated with any channel:

$$\begin{aligned} innerPendingDepositsSum_{i+1}(u) &= \\ &= innerPendingDepositsSum_i(u) - amount \end{aligned}$$

$$\begin{aligned} innerDepositBalanceSum_{i+1}(u) &= \\ &= innerDepositBalanceSum_i(u) + amount \end{aligned}$$

$$\begin{aligned} stateBalance_i(u) &= stateBalance_{i+1}(u) = \\ &= perceivedBal_i(u) = perceivedBal_{i+1}(u) \end{aligned}$$

- **pay** This algorithm deducts *amount* from the balance of *u* in channel c_{id} at time *i*, thus changing $stateBalance_i(u)$, but it also deducts *amount* from $perceivedBal_i(u)$, i.e.:

$$\begin{aligned} innerChannelBalanceSum_{i+1}(u) &= \\ &= innerChannelBalanceSum_i(u) - amount \end{aligned}$$

$$paid_{i+1}(u) = paid_i(u) - amount$$

$$\begin{aligned} stateBalance_i(u) &= stateBalance_{i+1}(u) = \\ &= perceivedBal_i(u) = perceivedBal_{i+1}(u) \end{aligned}$$

- **receivePayment** This algorithm adds *amount* to the balance of *u* in channel c_{id} at time *i*, thus changing $stateBalance_i(u)$, but it also adds *amount* to

$perceivedBal_i(u)$, i.e.:

$$\begin{aligned} innerChannelBalanceSum_{i+1}(u) &= \\ &= innerChannelBalanceSum_i(u) + amount \\ rvd_{i+1}(u) &= rvd_i(u) + amount \\ stateBalance_i(u) &= stateBalance_{i+1}(u) = \\ &= perceivedBal_i(u) = perceivedBal_{i+1}(u) \end{aligned}$$

- **settleChannel** This algorithm takes the current balance of u in channel c_{id} , and the sum of the deposits in the process of dissociation and deducts the total amount from u and it as a pending ledger operation, i.e.:

$$\begin{aligned} innerChannelBalance_{i+1}(u) &= 0 \\ innerPendingDepositsSum_{i+1}(u) &= 0 \\ innerPendingLedgerOpsSum_{i+1}(u) &= \\ &= innerPendingLedgerOpsSum_i(u) + \\ &+ innerChannelBalanceSum_i(u) + \\ &+ innerPendingDepositsSum_i(u) \\ stateBalance_i(u) &= stateBalance_{i+1}(u) = \\ &= perceivedBal_i(u) = perceivedBal_{i+1}(u) \end{aligned}$$

This concludes the inductive step, we proved that $stateBalance_t(u) = perceivedBal_t(u)$ for any time t during the execution σ . \square

Next we show that for any open channel c_{id} the sum of the balances on both sides of the channel is less or equal to the sum of the deposits associated with the channel.

We first denote by $deposits_t(u)$ all the deposits that at a given time t are associated with a given channel c_{id} :

$$\begin{aligned} deposits_t(u) &= \{amount \mid \exists deposit_id, isSymmetric, u : \\ &D(deposit_id) = (amount, u, c_{id}, isSymetric), \\ &PendingDeposits(deposit_id) = \perp\} \end{aligned}$$

We denote by $depositsSum_t(c_{id})$ the sum of the amounts of the deposits that are associated at a given time t with channel c_{id} :

$$depositsSum_t(c_{id}) = \sum_{amount \in deposits_t(u)} amount$$

We denote by $channelCapacity_t(c_{id})$ the sum of the capacities of the two users u and v which have a channel between them with channel id c_{id} at time t , i.e., for channel entry $C(c_{id}) = (u, v, amountU, amountV, isSymmetric)$ we denote:

$$channelCapacity_t(c_{id}) = amountU + amountV$$

Proposition 2. *At any given time t during the execution σ the sum of the deposits associated with a given channel c_{id} is always greater or equal to the balances of both users of the channel u and v , i.e.:*

$$channelCapacity_t(c_{id}) \leq depositsSum_t(c_{id}) \quad (1)$$

Proof. We will prove this by induction on the execution σ :
Inductive base. At the initial step 0: $\forall c_{id} : C(c_{id}) = \perp$. Therefore, there are no open channels in system at all.

Inductive step. We assume that at step i the induction assumption holds for all entries in C , i.e.,

$$channelCapacity_0(c_{id}) \leq depositsSum_0(c_{id}).$$

We will prove that at step $i + 1$ the proposition holds as well.

Let us look at all the operations in $\mathcal{F}_{Teechain}$. We note that the channel balance as defined above does not change if $\mathcal{F}_{Teechain}$ returns *fail* for any call, as the if statement in the beginning of each of its calls will cause it to return *fail* does not change any internal variable of $\mathcal{F}_{Teechain}$. Thus, we go over all operations that return *success*:

- **getLedgerBalance** This call does not affect the balance of any channel in C .
- **acceptLedgerPayment** This call does not affect the balance of any channel in C .
- **acceptLedgerPayment** This call does not affect the balance of any channel in C .
- **addDeposit** This call does not affect the balance of any channel in C .
- **removeDeposit** This call does not affect the balance of any channel in C .
- **openChannel** In this call a new channel entry in $C(c_{id})$ is generated in the form of $(u, v, 0, 0, \perp)$. Thus, no deposit is associated at step i with channel c_{id} , which means that $depositsSum_{i+1}(c_{id}) = channelCapacity_{i+1}(c_{id}) = 0$.
- **acceptChannelOpen** The only effect of this call on $C(c_{id})$ is that it changes the last argument of the entry $C(c_{id})$ from \perp to \top . This means that if at step i ?? holds then it also holds at step $i + 1$.
- **associateDeposit** In any successful call $associateDeposit(c_{id}, deposit_id)$, $\mathcal{F}_{Teechain}$ adds the deposit $amount$ to either $amountU$ or $amountV$, and changes the third argument of $D(deposit_id)$ to c_{id} , i.e., at step $i + 1$: the $amount$ of $deposit_id$ will be in $deposits_{i+1}(u)$, and $depositsSum_{i+1}(c_{id}) = depositsSum_i(c_{id}) + amount$ and $channelCapacity_{i+1}(c_{id}) = channelCapacity_i(c_{id}) + amount \Rightarrow channelCapacity_{i+1}(c_{id}) \leq depositsSum_{i+1}(c_{id})$.
- **acceptAssociateDeposit** This call does not affect the balance of any channel in C as it only changes the last argument of $D(deposit_id)$ from \perp to \top .
- **dissociateDeposit** In this case $amount$ is deducted from either $amountU$ or $amountV$, and $PendingDeposits(deposit_id)$ entry is generated, i.e.,

$$\begin{aligned} depositsSum_{i+1}(c_{id}) &= depositsSum_i(c_{id}) - amount \text{ and} \\ channelCapacity_{i+1}(c_{id}) &= channelCapacity_i(c_{id}) - amount \\ &\Rightarrow channelCapacity_{i+1}(c_{id}) \leq \\ &depositsSum_{i+1}(c_{id}). \end{aligned}$$

• **acceptDissociate** This algorithm only changes $PendingDeposits(deposit_id) = (u, \perp)$ to (u, \top) and does not affect the balance of any channel in C .

• **ackDissociate** This algorithm removes $PendingDeposits(deposit_id)$ and also changes the third argument of $D(deposit_id)$ to \perp , thus the deposit was not in $deposits_i(u)$ at step i and is not in $deposits_{i+1}(u)$ at step $i + 1$.

• **pay** This call deducts $amount$ from either $amountU$ or $amountV$ in $C(c_{id})$. In addition, in this call $\mathcal{F}_{Teechain}$ adds a new entry to $PendingPayments$ with a new generated $pending_payment_id$, i.e., $PendingPayments(pending_payment_id) = (v, c_{id}, amount)$. This means that $channelCapacity_{i+1}(c_{id}) = channelCapacity_i(c_{id}) - amount$, $deposits_{i+1}(u) = deposits_i(u) \Rightarrow channelCapacity_{i+1}(c_{id}) < deposits_{i+1}(u)$

• **receivePayment** In this call, $\mathcal{F}_{Teechain}$ adds the $amount$ in $PendingPayments(pending_payment_id)$ to $amountU$ or $amountV$ in $C(c_{id})$, and then removes $PendingPayments(pending_payment_id)$.

In order for the call $receivePayment$ to return $success$, there has to be at step i an entry $PendingPayments(pending_payment_id)$ in the form of $(v, c_{id}, amount)$. The only call in which $\mathcal{F}_{Teechain}$ adds a new entry to $PendingPayments$ is pay . This pay call needs to be called by either one of the parties in channel c_{id} and $amount$ is deducted in that call from $amountU$ or $amountV$.

In addition, no other call deducts $amount$ only from the right hand side of $??$, which means that, $channelCapacity_i(c_{id}) + amount \leq depositsSum_i(c_{id})$, $channelCapacity_{i+1}(c_{id}) = channelCapacity_i(c_{id}) + amount \Rightarrow channelCapacity_{i+1}(c_{id}) \leq depositsSum_{i+1}(c_{id})$.

• **settleChannel** This calls settles the channel c_{id} , and can be called twice:

- If this is the second time $settleChannel$ is called, then $C(c_{id})$ is removed, thus $channelCapacity_{i+1}(c_{id})$ is undefined at $i + 1$.
- If this is the first call to $settleChannel$, then after the calls ends at step $i + 1$, $C(c_{id})$ is updated s.t. $amountU = 0$.

In addition, all the deposits s.t. $\exists deposit_id, isSymmetric$:

$PendingDeposits(deposit_id) = (u, isSymmetric)$ are removed from D . The only deposits which have an entry in $PendingDeposits$ are deposits with $deposit_id$ s.t. $dissociateDeposit_u(deposit_id)$ was called during σ_i , i.e., $amount$ was already deducted from $channelCapacity_i(c_{id})$.

This means that $channelCapacity_{i+1}(c_{id}) = channelCapacity_i(c_{id}) - amountU = amountV$, $depositsSum_{i+1}(c_{id}) = depositsSum_i(c_{id})$, thus, $channelCapacity_{i+1}(c_{id}) \leq depositsSum_{i+1}(c_{id})$. \square

Finally, we prove that at any given time t , any user u has the ability to receive $stateBalance_t(u)$ by performing the operations of the balance algorithm A.4.

Proposition 3. *If a user u performs the operations described in balance correctness algorithm A.4 as a suffix to the prefix σ_t , interleaved with operation of other users, then for any time $t'' \geq t'$ such that $op_{t''} = getLedgerBalance(u)$ and $ret_{t''} = (success, amount)$, then $amount = stateBalance_{t'}(u)$.*

Proof. Let us look at the for sets of operations consisting the balance correctness algorithm (definition A.4): $OPS_u = (OPS_1, OPS_2, OPS_3)$.

• **innerDepositBalance_t(u)** Let us look at OPS_1 . This set consists of $removeDeposit_u$ calls to $\mathcal{F}_{Teechain}$ for each $deposit_id \in innerDeposits_t(u)$. $innerDepositBalanceSum_t(u)$ is defined as the sum of all those deposits. We proved in Lemma 2 that $\mathcal{F}_{Teechain}$ returns $(success, ledger_payment_id)$ for all these calls, and for each call adds the deposit amount $amount$ to $PendingLedgerPayments(deposit_id)$. This means that at time t_1 when all calls in OPS_1 have been called then:

$$\begin{aligned} innerDepositBalanceSum_{t_1}(u) &= 0 \\ innerPendingLedgerOpsSum_{t_1}(u) &= \\ &= innerPendingLedgerOpsSum_t(u) + \\ &\quad + innerDepositBalanceSum_t(u) \end{aligned}$$

• **innerChannelBalance_t(u), innerPendingDeposits_t(u)**

Let us look at OPS_2 . This set consists of $settleChannel_u(c_{id})$ calls for each channel $c_{id} \in innerChannels_t(u)$. $innerChannelBalanceSum_t(u)$ is defined as the sum of all u 's open channels' balances, and $innerPendingDeposits_t(u)$ is defined as all the deposits in the process of dissociation from a channel. We proved in Lemma 4 that $\mathcal{F}_{Teechain}$ returns $(success, ledger_payment_id)$ for all these calls, and for each call adds u 's channel balance $amountU$ to $PendingPayments(deposit_id)$.

In addition OPS_2 does not change any existing entries in $PendingLedgerPayments$, therefore not changing

$innerPendingLedgerOpsSum_{t_1}(u)$. Thus, at time t_2 when all calls in OPS_2 have been completed:

$$\begin{aligned} innerChannelBalanceSum_{t_2}(u) &= \\ &= innerPendingDepositsSum_{t_2}(u) = 0 \end{aligned}$$

$$\begin{aligned} innerPendingLedgerOpsSum_{t_2}(u) &= \\ &= innerPendingLedgerOpsSum_{t_1}(u) + \\ &\quad + innerChannelBalanceSum_{t_1}(u) + \\ &\quad + innerPendingDepositsSum_{t_1}(u) \end{aligned}$$

- **$innerPendingLedgerOpsSum_{t_1}(u)$** This set consists of $acceptLedgerPayment_u$ for each ledger payment ids $ledger_payment_id$ that were the return values of the operations in $OPS_1 \cup OPS_2$ in addition to all pending ledger operations in $innerPendingLedgerOpsSum_{t_1}(u)$. This means that at a time t_3 when the calls in OPS_3 finish successfully (as proved in lemma 6):

$$\begin{aligned} innerPendingLedgerOpsSum_{t_3}(u) &= \\ &= innerPendingLedgerOpsSum_{t_2}(u) - \\ &\quad - innerChannelBalanceSum_{t_1}(u) - \\ &\quad - innerDepositBalanceSum_{t_1}(u) = 0 \end{aligned}$$

$$\begin{aligned} L_{t_3}(u) &= L_{t_1}(u) + \\ &\quad + innerChannelBalanceSum_{t_1}(u) + \\ &\quad + innerDepositBalanceSum_{t_1}(u) + \\ &\quad + innerPendingDepositsSum_{t_1}(u) + \\ &\quad + innerPendingLedgerOpsSum_{t_1}(u) \end{aligned}$$

We note that t_3 is the time after all the operations in OPS_u have been invoked and returned successfully, and that $L_{t_3}(u) = stateBalance_{t_1}(u)$. Therefore, if any user calls $getLedgerBalance(u)$, $\mathcal{F}_{Teechain}$ will return $(success, amount)$ such that $amount = stateBalance_{t_1}(u)$. \square

We proved that at any point in time a user u can preform a series of calls to $\mathcal{F}_{Teechain}$ and receive her inner balance. Since the inner balance is always equal to u 's perceived balance and we showed that the ability of u to preform these operations do not affect the perceived balance of other users in the system then any user can choose to preform these operations and receive their balance.

We recall Theorem A.1:

[Balance Correctness Theorem] The ideal functionality $\mathcal{F}_{Teechain}$ achieves balance correctness.

This concludes our proof to the theorem, and since the ideal-world and the real-world are indistinguishable to any external environment \mathcal{E} then Teechain achieves balance correctness.

A.5 Multi-hop payments

Here we show that multi-hop payments satisfy balance correctness. As long as a multi-hop payment is not completed, the perceived balance of a user might be either post-payment or pre-payment (see §5). Thus, we define the perceived balance of a user in a multi-hop payment between u and v , where u is routing a payment of $amount$ to v . For execution trace σ let: t_1 be the time in σ at which u enters stage lock of the protocol; $t_2 > t_1$ be the time in σ at which v enters stage lock; $t_3 > t_2$ the time in σ at which v enters stage idle; and $t_4 > t_3$ the time in σ at which u ends the protocol and enters stage idle. See Fig. 2.

The users' *perceived balances* are as follows: For u , the perceived balance is: before t_1 as if $amount$ was not paid; after t_4 as if $amount$ was paid; between t_1 and t_4 either option is acceptable. For v , the perceived balance is: before t_2 as if $amount$ was not paid; after t_3 as if $amount$ was paid; between t_2 and t_3 either option is acceptable. The perceived balance of any intermediate party in the multi-hop payment does not change.

We prove Theorem A.1 by showing that every node p in a multi-hop payment (including u and v) can unilaterally reclaim their perceived balance at any point in time. We further show that if p settles, then all the channels of the multi-hop payment will always consistently settle in either the pre-payment or post-payment state. Note that single channel payments do not interfere with multi-hop payments, as all the channels in the multi-hop payment are locked (§5).

Stage: idle. If p is in stage idle, then all other nodes of the payment are either in stage idle or lock. Node p and all other nodes can only obtain the pre-payment settlement transaction and subsequently stop the protocol. In this stage, the perceived balance of both u and v reflects the pre-payment state, thus satisfying balance correctness.

Stage: lock. If p is in stage lock, all other nodes are either (i) in stage idle and in stage lock, or (ii) in stage lock and in stage sign. All nodes can only settle their channels at the pre-payment state.

Stage: sign. If p is in stage sign, all nodes are either (i) in stage lock and in stage sign, or (ii) in stage sign and in stage preUpdate. Case (i): If any node ejects, it settles its channels in the pre-payment state. This prevents progress and no node will reach the preUpdate stage. Node p can then similarly eject and settle its channels in the pre-payment state. Case (ii): Any node in the preUpdate stage might eject with \bar{r} . In this case, all channels will be settled in post-payment state.

Stage: preUpdate. If p is in stage preUpdate, all nodes are either (i) in stage sign and in stage preUpdate, or (ii) in stage preUpdate and in stage update. Case (i): Any node in stage sign may eject and settle its channels in the pre-payment state. Node p can then present this settlement transaction to its TEE as *PoPT* and obtain pre-payment settlement transactions for its channels. Node p can also voluntarily eject and obtain

$\bar{\tau}$. Placing $\bar{\tau}$ onto the blockchain fails if one of the channels was already settled, in which case p can obtain settlement transactions for its channels as above. Case (ii): Any node can eject and settle the multi-hop payment with $\bar{\tau}$. If nodes have reached **update**, then all nodes passed stage **sign**, therefore none can generate local settlements.

Stage: update. If p is in stage **update**, all nodes are either (i) in stage **preUpdate** and in stage **update**, or (ii) in stage **update** and in stage **postUpdate**. Case (i): All nodes can eject and settle the multi-hop payment with $\bar{\tau}$. None can generate individual settlements. Case (ii): Nodes in **postUpdate** can only settle their channels individually at post-payment state. Node p can present its TEE with single-channel settling transactions as *PoPT* and obtain settlement transactions to terminate in post-update state.

Stage: postUpdate. If p is in stage **postUpdate**, all nodes are either (i) in stage **update** and in stage **postUpdate**, or (ii) in stage **postUpdate** and in stage **idle**. Case (i): Nodes in the **update** stage can voluntarily settle the entire multi-hop payment with $\bar{\tau}$. Nodes in stage **postUpdate** can settle their local channels at post-payment, and provide node p with *PoPT* to do the same. Case (ii): All nodes can only settle their local channels at post-payment.

Stage: release. When p returns to the **release** stage, other nodes are either in **release**, or some are in stage **update**; all nodes can only settle their channels at the post-payment state. With this, we conclude that Teechains multi-hop payment satisfy balance correctness: (i) if either u or v are in the initial **idle** stage, they are both only able to settle pre-payment; (ii) between stage **lock** and **postUpdate**, both u and v may settle their channels in either pre-payment or post-payment state. However, they will always consistently settle the same state; (iii) once reaching stage **release**, both u and v will settle the post-payment state. The balance for any intermediate nodes does not change during the course of the payment routing. Thus, all participants in the multi-hop payment protocol are always able to reclaim their perceived balance.

This concludes our proof. We proved theorem A.1 and showed that the Teechain protocol (both channel and multi-hop payments) guarantee balance correctness.