

Multiple Range-Restricted Bidirectional Gated Recurrent Units with Attention for Relation Classification

Jonggu Kim

Computer Science and Engineering,
Pohang University of Science and
Technology (POSTECH)
Pohang, Republic of Korea
jgkimi@postech.ac.kr

Jong-Hyeok Lee

Computer Science and Engineering,
Pohang University of Science and
Technology (POSTECH)
Pohang, Republic of Korea
jhlee@postech.ac.kr

Abstract

Most of neural approaches to relation classification have focused on finding short patterns that represent the semantic relation using Convolutional Neural Networks (CNNs) and those approaches have generally achieved better performances than using Recurrent Neural Networks (RNNs). In a similar intuition to the CNN models, we propose a novel RNN-based model that strongly focuses on only important parts of a sentence using multiple range-restricted bidirectional layers and attention for relation classification. Experimental results on the SemEval-2010 relation classification task show that our model is comparable to the state-of-the-art CNN-based and RNN-based models that use additional linguistic information.

1 Introduction

Relation classification is to select the relation class that implies the relation of the two nominals (e_1 , e_2) in the given text. For instance, given the following sentence, “The $\langle e_1 \rangle$ **phone** $\langle /e_1 \rangle$ went into the $\langle e_2 \rangle$ **washer** $\langle /e_2 \rangle$.”, where $\langle e_1 \rangle$, $\langle /e_1 \rangle$, $\langle e_2 \rangle$, $\langle /e_2 \rangle$ are position indicators that represent the starting and ending positions of nominals, the goal is to find the actual relation *Entity-Destination* of **phone** and **washer**. The task is important because the results can be utilized in other Natural Language Processing (NLP) applications like question answering and information retrieval.

Recently, Neural Network (NN) approaches to relation classification have been spotlighted since they do not need any handcrafted features but even obtain better performances than traditional models. Such NNs can be simply classified into CNN-based and RNN-based models, and they capture

slightly different features to predict a relation class.

In general, CNN-based models can only capture local features while RNN-based models are expected to capture global features as well, but the performances of CNN-based models are better than RNN-based models. That could be thought that most of relation-related terms are not scattered but intensively positioned as short expressions on a given sentence, and further even if RNNs are expected to learn such information automatically, it cannot be easily done contrary to our expectation. To overcome the limitation of RNNs, most of the recent work using RNNs have used additional linguistic information like Shortest Dependency Path (SDP), which can reduce the effect of noise words when predicting a relation.

In this paper, we propose a simple RNN-based model that strongly pays attention to nominal-related and relation-related parts with multiple range-restricted RNN variants called Gated Recurrent Units (GRUs) (Cho et al., 2014) and attention. On the SemEval-2010 Task 8 dataset (Hendrickx et al., 2009), our model with only pre-trained word embeddings achieved the F1 score of 84.3%, which is comparable with the state-of-the-art CNN-based and RNN-based models that use additional linguistic resources such as Part-Of-Speech (POS) tags, WordNet and SDP. Our contributions are summarized as follows:

- For relation classification, without any additional linguistic information, we suggest modeling nominals and a relation in a sentence with specified range-restriction standards and attention using RNNs.
- We show how effective abstracting nominal parts, a relation part and both separately with the restrictions is to relation classification.

2 Related Work

Traditional approaches to relation classification are to find important features of relations with various linguistic processors and utilize them to train classifiers. For instance, Rink and Harabagiu (2010) uses NLP tools to extract linguistic features and trains an SVM model with the features.

Recently, many deep learning approaches have been proposed. Zeng et al. (2014) proposes a model based on CNNs to automatically learn important N-gram features. dos Santos et al. (2015) proposes a ranking loss function to well distinguish between the real classes and *Other* class. To capture long distance patterns, RNN-based, usually using Long Short-Term Memory (LSTM), approaches have also appeared, one of which is Zhang and Wang (2015). The model simply feeds on all words in a sentence, then captures important one through the max-pooling operation. Xu et al. (2015b) and Miwa and Bansal (2016) propose other RNN models using SDP to ignore noise words in a sentence. In addition, Liu et al. (2015) and Cai et al. (2016) propose hybrid models of RNN and CNN.

One of the most related work to ours is the attention-based bidirectional LSTM (att-BLSTM) (Zhou et al., 2016). The model uses bidirectional LSTM and attention techniques to abstract important parts. However, the att-BLSTM does not distinguish roles of each part in a sentence, which could not involve sensitive attention. Another of the most related work is by Zheng et al. (2016). They try to capture nominal-related and relation-related patterns with CNNs and use neither restrictions nor attention mechanism.

3 The Proposed Model

Figure 1 shows the architecture of the proposed model, which will be described in the subsections.

3.1 Word Embeddings

Our model first takes word embeddings to represent a sentence at the word level. Given a sentence S consisting of N words, it can be represented as $S = \{w_1, w_2, w_3, \dots, w_N\}$. We convert each one-hot vector w_t by multiplying with the word embedding matrix $W_e \in \mathbb{R}^{d_e \times |V|}$:

$$e_t = W_e w_t. \quad (1)$$

Then, the sentence can be represented as $S_e = \{e_1, e_2, \dots, e_N\}$.

3.2 Range-Restricted Bidirectional GRUs

To capture information of two nominals and one relation, our model consists of three bidirectional GRU layers with range restrictions. A GRU is a kind of RNN variant to alleviate the gradient-vanishing problem like LSTM, but it has fewer weights than LSTM. In a GRU, the t -th hidden h_t with reset gate r_t and update gate z_t is computed as:

$$r_t = \sigma(W_r e_t + U_r h_{t-1}), \quad (2)$$

$$z_t = \sigma(W_z e_t + U_z h_{t-1}), \quad (3)$$

$$\tilde{h}_t = \tanh(W e_t + U(r_t \odot h_{t-1})), \quad (4)$$

$$h_t = z_t \odot h_{t-1} + (1 - z_t) \odot \tilde{h}_t, \quad (5)$$

where σ is the logistic sigmoid function.

The range restrictions can be done by using masking techniques to restrict the input range of the three bidirectional GRUs. Therefore, they should be conducted under three separate standards, but because the standards for two nominals are the same, we introduce two kinds of standards. First, to capture each nominal information, only the $p_{en} \pm k$ positioned words are regarded as input to the corresponding bidirectional GRU layer, where p_{en} is the position of nominal e1 or e2 and k is a hyperparameter affecting their window size. Second, for the relation GRU layer, the input range is set to $[p_{e1}, p_{e2}]$ or $[p_{e2}, p_{e1}]$ according to the relative order of the nominals in a sentence, which means that the range is from the formerly-appearing nominal to the latterly-appearing nominal.

After the sentence representation at word level S_e is fed into the six GRU layers (three GRU layers in two directions) under the restrictions, various hidden units are finally generated from the layers. We call the hidden units of each GRU layer $\vec{H}_{e1}, \overleftarrow{H}_{e1}, \vec{H}_{e2}, \overleftarrow{H}_{e2}, \vec{H}_{rel}, \overleftarrow{H}_{rel}$ for convenience in the next subsection.

3.3 Sentence-level Representation

Among the hidden units of the six range-restricted GRUs, the model selects important parts by using direct selection from hidden layers and the attention mechanism.

To extract e1 and e2 information, we propose to directly select hidden units at each nominal position in the e1 and e2 bidirectional GRUs, and to

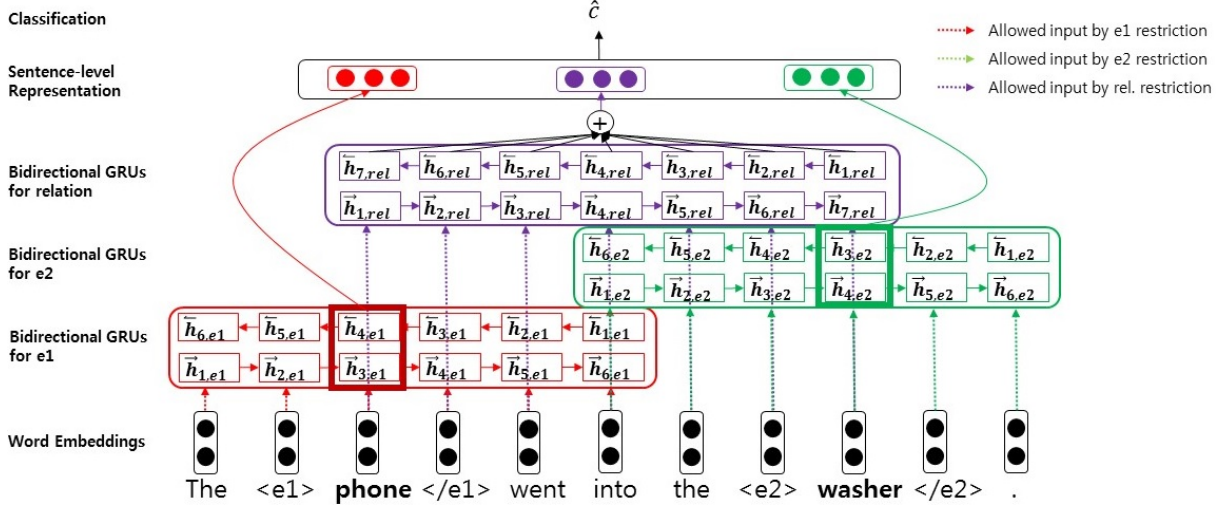

Figure 1: Multiple Range-Restricted Bidirectional GRUs with Attention ($k = 3$)

sum them to construct $v_{e1}, v_{e2} \in \mathbb{R}^{d_h}$, respectively as:

$$v_{e1} = \vec{h}_{e1} + \overleftarrow{h}_{e1}, \quad (6)$$

$$v_{e2} = \vec{h}_{e2} + \overleftarrow{h}_{e2}, \quad (7)$$

where each directional h_{en} represents hidden units at the en positions in the directional H_{en} .

To abstract relation information, we adopt the attention mechanism that has been widely used in many areas (Bahdanau et al., 2014; Hermann et al., 2015; Chorowski et al., 2015; Xu et al., 2015a). We use the attention mechanism (Zhou et al., 2016), but we apply it to each directional GRU layer independently to capture more informative parts with the flexibility. The forward directional relation-abstracted vector \vec{v}_{rel} is computed as (\overleftarrow{v}_{rel} in the same way):

$$\vec{M} = \tanh(\vec{H}_{rel}), \quad (8)$$

$$\vec{\alpha} = \text{softmax}(\vec{w}_{att}^T \vec{M}), \quad (9)$$

$$\vec{v}_{rel} = \vec{H}_{rel} \vec{\alpha}^T, \quad (10)$$

where \vec{w}_{att} is a trained attention vector for the forward layer.

Then, we sum \vec{v}_{rel} and \overleftarrow{v}_{rel} to make the relation-abstracted vector $v_{rel} \in \mathbb{R}^{d_h}$:

$$v_{rel} = \vec{v}_{rel} + \overleftarrow{v}_{rel}. \quad (11)$$

Lastly, the final representation $v_{fin} \in \mathbb{R}^{3d_h}$ is constructed by concatenating them:

$$v_{fin} = v_{e1} \oplus v_{rel} \oplus v_{e2}, \quad (12)$$

where \oplus is a concatenation operator.

3.4 Classification

Our model uses scores of how similar the v_{fin} is to each class embedding to predict the actual relation (dos Santos et al., 2015). Concretely, we propose a feed-forward layer in which a weight matrix $W_c \in \mathbb{R}^{classes \times 3d_h}$ and a bias vector $b_c \in \mathbb{R}^{classes}$ can be regarded as a set of the class embeddings. In other words, the inner-product of each row vector in W_c with v_{fin} represents the similarity between them in vector space, so the class score vector $s_c \in \mathbb{R}^{classes}$ is just computed as:

$$s_c = W_c v_{fin} + b_c. \quad (13)$$

Then, the model chooses the max-valued index that represents the most probable class label \hat{c} except that every value in the s_c is negative. In the exceptional case, \hat{c} is chosen as *Other* (dos Santos et al., 2015).

3.5 Training Objectives

We adopt the ranking loss function (dos Santos et al., 2015) to train the networks. Let s_{cy+} the score of the \hat{c} , and s_{cc-} the competitive score that is the best score excluding s_{cy+} for convenience. Then, the loss is computed as:

$$L = \log(1 + \exp(\gamma(m^+ - s_{cy+}))) + \log(1 + \exp(\gamma(m^- + s_{cc-}))), \quad (14)$$

where m^+ and m^- represent margins and γ is a factor that magnifies the gap between the score and the margin.

Model	Additional Features (Except Word Embeddings)	F1
SDP-LSTM (Xu et al., 2015b)	- POS, WordNet, dependency parse, grammar relation	83.7
DepNN (Liu et al., 2015)	- NER, dependency parse	83.6
SPTree (Miwa and Bansal, 2016)	- POS, dependency parse	84.4
MixCNN+CNN (Zheng et al., 2016)	- None	84.8
att-BLSTM (Zhou et al., 2016)	- None	84.0
Our Model (att-BGRU)	- None	82.9
Our Model (Relation only)	- None	83.0
Our Model (Nominals only)	- None	81.4
Our Model (Nominals and Relation)	- None	84.3

Table 1: Comparison with the results of the state-of-the-art models

4 Experiments

For the experiments, we implement our model in Python using Theano (Theano Development Team, 2016) and use the model with the following descriptions.

4.1 Datasets and Settings

We conduct the experiments with SemEval-2010 Task 8 dataset (Hendrickx et al., 2009), which contains 8,000 sentences as the training dataset, and 2,717 sentences as the test dataset. A sentence consists of two nominals (e_1 , e_2), and a relation between them. Ten relation types are considered: Nine specific types (*Cause-Effect*, *Component-Whole*, *Content-Container*, *Entity-Destination*, *Entity-Origin*, *Instrument-Agency*, *Member-Collection*, *Message-Topic* and *Product-Producer*), and the *Other* class. The specific types have directionality, so a total of $2 \times 9 + 1 = 19$ relation classes exist.

We use 10-fold cross-validation to tune the hyperparameters. We adopt the 100-dimensional word vectors trained by Pennington et al. (2014) as initial word embeddings and select the hidden layer dimension d_n of 100, the learning rate of 1.0 and the batch size of 10. AdaDelta (Zeiler, 2012) is used as the learning optimizer. Also, we adapt the dropout (Hinton et al., 2012) to the word embeddings, GRU hidden units, and feed-forward layer with dropout rates of 0.3, 0.3 and 0.7, respectively, and use the k of 3. We adopt the position indicator that regards $\langle e_1 \rangle$, $\langle /e_1 \rangle$, $\langle e_2 \rangle$ and $\langle /e_2 \rangle$ as single words (Zhang and Wang, 2015).

We set m^+ , m^- and γ to 2.5, 0.5 and 2.0, respectively (dos Santos et al., 2015) and adopt the L2 regularization with 10^{-5} . The official scorer is used to evaluate our model in the macro-averaged F1 (excluding *Other*).

4.2 Results

In Table 1, our results are compared with the other state-the-art models. Our model with only pre-trained word embeddings achieved the F1 score of 84.3%, which is comparable to the state-of-the-art models.

Furthermore, we investigated the effects of extracting relation, nominals and both of them. Attention-based bidirectional GRUs with no restriction (att-BGRU) were also tested as a reimplementation of the att-BLSTM. Here, our finding is that the restricted version of the att-BGRU (the relation only model) is not significantly better, but by abstracting nominals together, the model achieves higher F1 score. That indicates even if the ranges are slightly overlapped, they capture distinct features and improve the performance.

5 Conclusion

This paper proposed a novel model based on multiple range-restricted RNNs with attention. The proposed model achieved a comparable performance to the state-of-the-art models without any additional linguistic information.

References

- Dzmitry Bahdanau, Kyunghyun Cho, and Yoshua Bengio. 2014. Neural machine translation by jointly learning to align and translate. *arXiv preprint arXiv:1409.0473*.
- Rui Cai, Xiaodong Zhang, and Houfeng Wang. 2016. Bidirectional recurrent convolutional neural network for relation classification. In *Proceedings of the 54th Annual Meeting of the Association for Computational Linguistics (Volume 1: Long Papers)*. Association for Computational Linguistics, pages 756–765. <https://doi.org/10.18653/v1/P16-1072>.
- Kyunghyun Cho, Bart van Merriënboer, Caglar Gulcehre, Dzmitry Bahdanau, Fethi Bougares, Holger Schwenk, and Yoshua Bengio. 2014. Learning phrase representations using rnn encoder–decoder for statistical machine translation. In *Proceedings of the 2014 Conference on Empirical Methods in Natural Language Processing (EMNLP)*. Association for Computational Linguistics, pages 1724–1734. <https://doi.org/10.3115/v1/D14-1179>.
- Jan K Chorowski, Dzmitry Bahdanau, Dmitriy Serdyuk, Kyunghyun Cho, and Yoshua Bengio. 2015. Attention-based models for speech recognition. In *Advances in Neural Information Processing Systems*. pages 577–585. <http://papers.nips.cc/paper/5847-attention-based-models-for-speech-recognition.pdf>.
- Cicero dos Santos, Bing Xiang, and Bowen Zhou. 2015. Classifying relations by ranking with convolutional neural networks. In *Proceedings of the 53rd Annual Meeting of the Association for Computational Linguistics and the 7th International Joint Conference on Natural Language Processing (Volume 1: Long Papers)*. Association for Computational Linguistics, pages 626–634. <https://doi.org/10.3115/v1/P15-1061>.
- Iris Hendrickx, Nam Su Kim, Zornitsa Kozareva, Preslav Nakov, Diarmuid Ó Séaghdha, Sebastian Padó, Marco Pennacchiotti, Lorenza Romano, and Stan Szpakowicz. 2009. Semeval-2010 task 8: Multi-way classification of semantic relations between pairs of nominals. In *Proceedings of the Workshop on Semantic Evaluations: Recent Achievements and Future Directions (SEW-2009)*. Association for Computational Linguistics, pages 94–99. <http://aclweb.org/anthology/W09-2415>.
- Karl Moritz Hermann, Tomas Kocisky, Edward Grefenstette, Lasse Espeholt, Will Kay, Mustafa Suleyman, and Phil Blunsom. 2015. Teaching machines to read and comprehend. In *Advances in Neural Information Processing Systems*. pages 1693–1701. <https://doi.org/10.1002/trtr.1467>.
- Geoffrey E Hinton, Nitish Srivastava, Alex Krizhevsky, Ilya Sutskever, and Ruslan R Salakhutdinov. 2012. Improving neural networks by preventing co-adaptation of feature detectors. *arXiv preprint arXiv:1207.0580*.
- Yang Liu, Furu Wei, Sujian Li, Heng Ji, Ming Zhou, and Houfeng WANG. 2015. A dependency-based neural network for relation classification. In *Proceedings of the 53rd Annual Meeting of the Association for Computational Linguistics and the 7th International Joint Conference on Natural Language Processing (Volume 2: Short Papers)*. Association for Computational Linguistics, pages 285–290. <https://doi.org/10.3115/v1/P15-2047>.
- Makoto Miwa and Mohit Bansal. 2016. End-to-end relation extraction using lstms on sequences and tree structures. In *Proceedings of the 54th Annual Meeting of the Association for Computational Linguistics (Volume 1: Long Papers)*. Association for Computational Linguistics, pages 1105–1116. <https://doi.org/10.18653/v1/P16-1105>.
- Jeffrey Pennington, Richard Socher, and Christopher Manning. 2014. Glove: Global vectors for word representation. In *Proceedings of the 2014 Conference on Empirical Methods in Natural Language Processing (EMNLP)*. Association for Computational Linguistics, pages 1532–1543. <https://doi.org/10.3115/v1/D14-1162>.
- Bryan Rink and Sanda Harabagiu. 2010. Utd: Classifying semantic relations by combining lexical and semantic resources. In *Proceedings of the 5th International Workshop on Semantic Evaluation*. Association for Computational Linguistics, pages 256–259. <http://aclweb.org/anthology/S10-1057>.
- Theano Development Team. 2016. Theano: A Python framework for fast computation of mathematical expressions. *arXiv e-prints* abs/1605.02688. <http://arxiv.org/abs/1605.02688>.
- Kelvin Xu, Jimmy Ba, Ryan Kiros, Kyunghyun Cho, Aaron Courville, Ruslan Salakhutdinov, Richard S Zemel, and Yoshua Bengio. 2015a. Show, attend and tell: Neural image caption generation with visual attention. *arXiv preprint arXiv:1502.03044* 2(3):5.
- Yan Xu, Lili Mou, Ge Li, Yunchuan Chen, Hao Peng, and Zhi Jin. 2015b. Classifying relations via long short term memory networks along shortest dependency paths. In *Proceedings of the 2015 Conference on Empirical Methods in Natural Language Processing (EMNLP)*. Association for Computational Linguistics, pages 1785–1794. <https://doi.org/10.18653/v1/D15-1206>.
- Matthew D Zeiler. 2012. Adadelta: an adaptive learning rate method. *arXiv preprint arXiv:1212.5701*.
- Daojian Zeng, Kang Liu, Siwei Lai, Guangyou Zhou, and Jun Zhao. 2014. Relation classification via convolutional deep neural network. In *Proceedings of COLING 2014, the 25th International Conference on Computational Linguistics: Technical Papers*. Dublin City University and Association for Computational Linguistics, pages 2335–2344. <http://aclweb.org/anthology/C14-1220>.

Dongxu Zhang and Dong Wang. 2015. Relation classification via recurrent neural network. *arXiv preprint arXiv:1508.01006* .

Suncong Zheng, Jiaming Xu, Peng Zhou, Hongyun Bao, Zhenyu Qi, and Bo Xu. 2016. A neural network framework for relation extraction: Learning entity semantic and relation pattern. *Knowledge-Based Systems* 114:12–23. <https://doi.org/10.1016/j.knosys.2016.09.019>.

Peng Zhou, Wei Shi, Jun Tian, Zhenyu Qi, Bingchen Li, Hongwei Hao, and Bo Xu. 2016. Attention-based bidirectional long short-term memory networks for relation classification. In *Proceedings of the 54th Annual Meeting of the Association for Computational Linguistics (Volume 2: Short Papers)*. Association for Computational Linguistics, pages 207–212. <https://doi.org/10.18653/v1/P16-2034>.