

Syntax Aware LSTM Model for Chinese Semantic Role Labeling

Feng Qian², Lei Sha¹, Baobao Chang¹, Lu-chen Liu², Ming Zhang²

¹ Key Laboratory of Computational Linguistics, Ministry of Education
School of Electronics Engineering and Computer Science, Peking University

² Institute of Network Computing and Information Systems
School of Electronics Engineering and Computer Science, Peking University
nickqianusa@gmail.com, {shalei, chbb}@pku.edu.cn
{liuluchen292, mzhang_cs}@pku.edu.cn

Abstract

Traditional approaches to Semantic Role Labeling (SRL) depend heavily on manual feature engineering. Recurrent neural network (RNN) with long-short-term memory (LSTM) only treats sentence as sequence data and can not utilize higher level syntactic information. In this paper, we propose Syntax Aware LSTM (SA-LSTM) which gives RNN-LSTM ability to utilize higher level syntactic information gained from dependency relationship information. SA-LSTM also assigns different trainable weights to different types of dependency relationship automatically. Experiment results on Chinese Proposition Bank (CPB) show that, even without pre-training or introducing any other extra semantically annotated resources, our SA-LSTM model still outperforms the state of the art significantly base on Student's t-test ($p < 0.05$). Trained weights of types of dependency relationship form a stable and self-explanatory pattern.

1 Introduction

The task of SRL is to recognize arguments of a given predicate in a sentence and assign semantic role labels. Since SRL can give a lot of semantic information, and can help in sentence understanding, a lot of work has done on it either in English or in other languages. Figure 1 shows an example from Chinese Proposition Bank (CPB)(Xue and Palmer, 2003).

Traditional methods use statistical classifiers such as CRF, MaxEntropy and SVM (Sun and Jurafsky, 2004; Xue, 2008; Ding and Chang, 2008, 2009; Sun, 2010) to do classification according to manually designed features. By manual feature

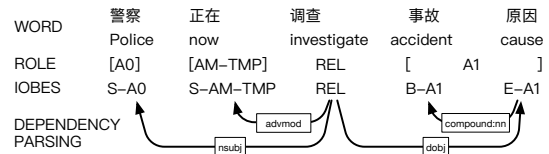

Figure 1: A sentence from CPB with semantic role label and dependency parsing information

engineering, traditional models can easily take into account lexical, syntactic and other information. However, manual feature engineering costs a lot of time, and also, even though complex features are designed, long-distance relationships in a sentence are still hard to capture.

Most recent work uses recurrent neural network, among them, RNN with bidirectional long-short-term memory (LSTM) preforms well (Collobert and Weston, 2008; Zhou and Xu, 2015; Wang et al., 2015; Li et al., 2016). RNN-LSTM SRL model greatly alleviates the burden of feature engineering and can also model long distance relationships. However, RNN-LSTM simply treats language as sequence data, so that it fails to explicitly model syntactic structure of a sentence like traditional methods do, which is proved to be crucial to SRL by traditional model(Xue, 2008).

Considering these problems, we propose Syntax Aware LSTM (SA-LSTM) to give RNN-LSTM ability to utilize higher level syntactic information gained from dependency relationship. For example, in Figure 1, arrowed line stands for dependency relationship, which is regarded as higher level syntactic information. We add additional connections to ordinary RNN-LSTM in order to make use of such information. The modified architecture is shown in Figure 2. Experiment results show that our SA-LSTM reaches 79.60% F_1 score on CPB database. Even without pre-training or introducing any other extra semantically annotated

resources, this is the best ever published F_1 score on CPB dataset, outperforming last state of the art significantly base on Student’s t-test ($p < 0.05$).

To take dependency relationship type into account, we introduce trainable weights for different types of dependency relationship. Important kinds of relationship are given larger weights while unimportant ones are given smaller weights. When observing different groups of trained weights, we find a stable and self-explanatory pattern, which further validates our SA-LSTM model.

2 Syntax Aware LSTM

We base our model on bidirectional RNN-LSTM, which can both alleviate the burden of feature engineering and keep long distance memory. We propose Syntax Aware LSTM (SA-LSTM) to enable LSTM to make use of higher level syntactic information.

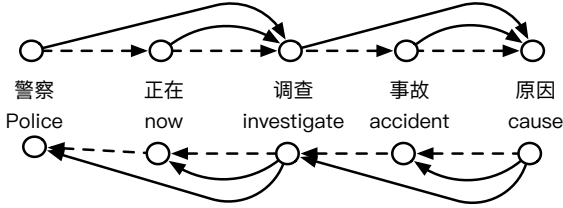

Figure 2: SA-LSTM architecture: A \bigcirc stands for one word. Dotted arrows stand for original neighbor connections of LSTM. Solid arrows stand for dependency relationship connections. As conventional bidirectional LSTM, we assume dependency relationship is bidirectional, and dependency connections can be introduced in both left-to-right and right-to-left directions.

2.1 Conventional Bi LSTM Model for Chinese SRL

For each word w_t in a sentence, current $cell_t$ consists of six internal vectors, \tilde{C} , g_i , g_f , g_o , C_t , and h_t .

$$z_t = f(W_1 x_t) \quad (1)$$

x_t is one-hot feature representation of word w_t generated automatically as (Wang et al., 2015) did. z_t is one-hot feature embedding for word w_t .

$W_1 \in \mathbb{R}^{n_1 \times n_0}$. n_0 is the length of word repre-

sentation.

$$\begin{aligned} \tilde{C} &= f(W_c z_t + U_c h_{t-1} + b_c) \\ g_j &= \sigma(W_j z_t + U_j h_{t-1} + b_j) \quad j \in \{i, f, o\} \\ C_t &= g_i \odot \tilde{C} + g_f \odot C_{t-1} \\ h_t &= g_o \odot f(C_t) \end{aligned} \quad (2)$$

\tilde{C} is the candidate value of the current cell state. g is gate used to control the flow of information between cells. C_t is the current cell state.

$$\begin{aligned} W_x, x \in \{c, i, f, o\} &\in \mathbb{R}^{n_h \times n_1} \\ U_x, x \in \{c, i, f, o\} &\in \mathbb{R}^{n_h \times n_h} \end{aligned} \quad (3)$$

As convention, f stands for \tanh and σ stands for sigmoid . \odot means the element wise multiplication.

$$a_t = [\vec{h}_t^T, \overset{\leftarrow}{h}_t^T] \quad (4)$$

Where h_t^T is the transpose of h_t . h_t is hidden state of $cell_t$. In order to make use of bidirectional information, the forward \vec{h}_t^T and backward $\overset{\leftarrow}{h}_t^T$ are concatenated together to make use of information from both directions.

$$o_t = W_3 f(W_2 a_t) \quad (5)$$

$W_2 \in \mathbb{R}^{n_3 \times n_2}$, n_2 is $2 \times h_t$, $W_3 \in \mathbb{R}^{n_4 \times n_3}$ and n_4 is the number of tags in IOBES tagging schema. Finally, o_t is the result vector with each dimension corresponding to the score of each semantic role tag. We add a hidden layer when calculating o_t .

2.2 Syntax Aware LSTM Model for Chinese SRL

Structure of our SA-LSTM is shown in Figure 3. The most significant change we make to original RNN-LSTM is shown in the shaded area. S_t is the weighted sum of h_i from all previous dependency related cells in a sentence. By introducing dependency related h_i into current $cell_t$, we explicitly take syntactic information into account and give SA-LSTM ability to utilize syntactic information.

S_t stands for higher level syntax information, which is the essence of Syntax Aware LSTM. By using α in equation 7, we assign weight evenly to different types of dependency relationship.

$$S_t = f\left(\sum_{i=0}^{t-1} \alpha \times h_i\right) \quad (6)$$

where

$$\alpha = \begin{cases} 1 & \text{exists dependency relationship} \\ & \text{between } w_i \text{ and } w_t \\ 0 & \text{Otherwise} \end{cases} \quad (7)$$

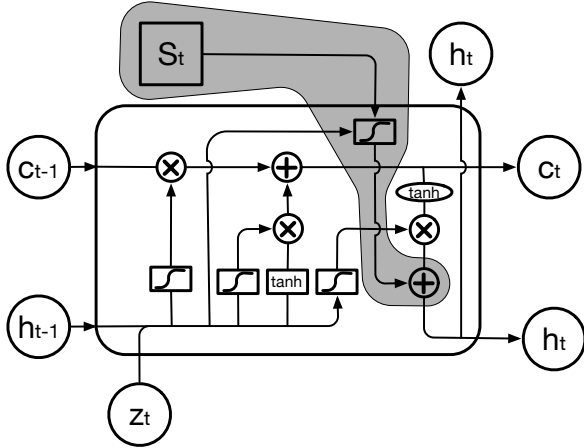

Figure 3: Cell Structure of Syntax Aware LSTM

To avoid current cell information from diluting by S_t , we add a gate g_s to constrain the information from S_t .

$$g_s = \sigma(W_s z_t + U_s h_{t-1} + b_s) \quad (8)$$

To protect the original sentence information from being diluted by S_t , we add S_t to hidden layer vector h_t instead of cell state C_t .

So h_t in our SA-LSTM cell is calculated as:

$$h_t = g_o \odot f(C_t) + g_s \odot S_t \quad (9)$$

However, intuitively, different types of dependency relationships should be regarded differently. A very natural idea is to assign weights for different types of dependency relationship. We further improve the way α is calculated from equation 7 to equation 10.

$$\alpha = \begin{cases} \alpha_{type} & \text{exists dependency relationship} \\ & \text{between } w_i \text{ and } w_t \\ 0 & \text{Otherwise} \end{cases} \quad (10)$$

Each *type* of dependency relationship is assigned a trainable weight α_{type} . The weight is used to indicate importance. By using α_{type} , we are able to differentiate important kinds of relationship from unimportant kinds and make better use of syntactic information. α_{type} is trainable and a group of trained weights can form a pattern.

2.3 Training Criteria

We use maximum likelihood criterion to train our model. Stochastic gradient ascent algorithm is used to optimize the parameters. Global normalization is applied.

Given a training pair $T = (x, y)$ where T is the current training pair, x denotes current training sentence, and y is the corresponding correct answer. $y_t = k$ means that the t -th word has the k -th semantic role label. The score of o_t is calculated as:

$$s(x, y, \theta) = \sum_{t=1}^{N_i} o_{ty_t} \quad (11)$$

where N_i is the word number of current sentence and θ stands for all parameters. So the log likelihood of a single sentence is

$$\begin{aligned} \log p(y|x, \theta) &= \log \frac{\exp(s(x, y, \theta))}{\sum_{y'} \exp(s(x, y', \theta))} \\ &= s(x, y, \theta) - \log \sum_{y'} \exp(s(x, y', \theta)) \end{aligned}$$

where y' ranges from all valid paths of tagging.

3 Experiment

3.1 Experiment setting

We use CPB 1.0 as previous works did, in order to compare our method with theirs. We also follow the same data setting (Xue, 2008; Sun et al., 2009). We divide the data into three parts: training set which consists of 648 files (from chtb.081 to chtb.899); development set which consists of 40 files (from chtb.041 to chtb.080); and test set which consists of 72 files (from chtb.001 to chtb.040 and chtb.900 to chtb.931).

We use Stanford Parser (Chen and Manning, 2014) to get dependency relationship information, which take the form of Universal Dependency (Nivre et al., 2016).

Dimension of our hyper parameters are tuned according to development corpus and are shown in Table 1.

Experiment code, related files, trained parameters are available on request.

Hyper Params	n_1	n_h	n_2	n_3	learning-rate
dim	200	100	200	100	0.001

Table 1: Hyper parameter dimensions

3.2 Syntax Aware LSTM Performance

¹Wang et al. used extra heterogeneous annotated corpus.

²Li et al. used English Proposition Bank.

³Our SA-LSTM does not use any extra annotated corpus like Wang et al. and Li et al. did.

Method	F_1 %
Xue(2008)	71.90
Sun et al.(2009)	74.12
Yand and Zong(2014)	75.31
Wang et al.(2015)(Random initialized)	77.09
Wang et al.(2015)(With extra resource) ¹	77.59
Sha et al.(2016)	77.69
Li et al.(2016)(With extra resource) ²	78.39
Our SA-LSTM(Random Initialized) ³	79.60

Table 2: Results comparison on CPB

As shown in Table 2, our SA-LSTM reach a 79.60% F_1 score on CPB dataset. To the best of our knowledge, this is the best F_1 score ever published on CPB dataset.

Wang et al. (2015) used bi RNN-LSTM with random initialization and got 77.09%, while our SA-LSTM reach 79.60% with random initialization. This means compares to RNN-LSTM, SA-LSTM is able to utilize higher level syntactic information and improves the result.

Further more, while Wang et al.(2015)(77.59%) used heterogeneous annotated corpus as extra resources and Li et al.(2016)(78.39%, current state of the art) used English Proposition Bank as extra resources, our method(79.60%) does not use any extra annotated corpus resources and still outperforms the state of the art significantly. This suggests that our model has innate advantage than previous ones.

3.3 Pattern Revealed by Trained Weights

The visualization of three groups of trained weights is shown in Figure 4.

More important types are assigned larger weights and vice versa. In our experiment result, three groups of trained weights form a stable and self-explanatory pattern, which reflects the relative importance between dependency relationship types.

Dependency relationship type *dobj* receives the highest weight after training. *dobj* is defined as “second core argument” by Universal Dependency, which means *dobj* can provide rich high level syntactic information. This corresponds to our result that *dobj* got the highest weight in our system.

The second highest weight is assigned automatically to *case*. The *case* relationship can indicates important objective and provides important syntactic information. That is why *case* is considered

second important by our system.

The result shows that some kinds of dependency relationship are helpful while some are not. By assigning different weights we are able to choose those helpful types and make better use of them. The stable and self-explanatory pattern also further proves that our SA-LSTM model is reliable.

4 Related works

Semantical role labeling (SRL) was first defined by Gildea and Jurafsky(2002), and they offered a statistical system trained on FrameNet. Sun and Jurafsky(2004) did early research on Chinese SRL and got promising result without large annotated SRL corpus. To standardize Chinese SRL research, Xue and Palmer built the Chinese Proposition Bank(Xue and Palmer, 2003). Later Xue and Palmer(2005) and Xue(2008) did more complete and comprehensive research on Chinese SRL. Ding and Chang(2009) proposed a word based Chinese SRL system. Sun et al.(2009) extended the work of Chen et al.(2006) using shallow parsing, which use partial parses as inputs. Yang and Zong (2014) proposed multi predicate SRL and showed improvement both on Chinese and English Proposition Bank.

Collobert and Weston(2008) proposed a neural network method for SRL. Zhou and Xu(2015) proposed RNN-LSTM based method for English SRL. Wang et al.(2015) proposed a bidirectional RNN-LSTM method for Chinese SRL on which our method was based. Some methods(Wang et al., 2015; Li et al., 2016) use extra external resources to enhance SRL task. Among them Wang used heterogeneous annotated SRL corpus and Li used English Proposition Bank. Sha et al.(2016) use QOM method to model the argument-argument interaction in SRL structure, however, QOM is just a post-processing method. Our SA-LSTM capture higher level syntactic rela-

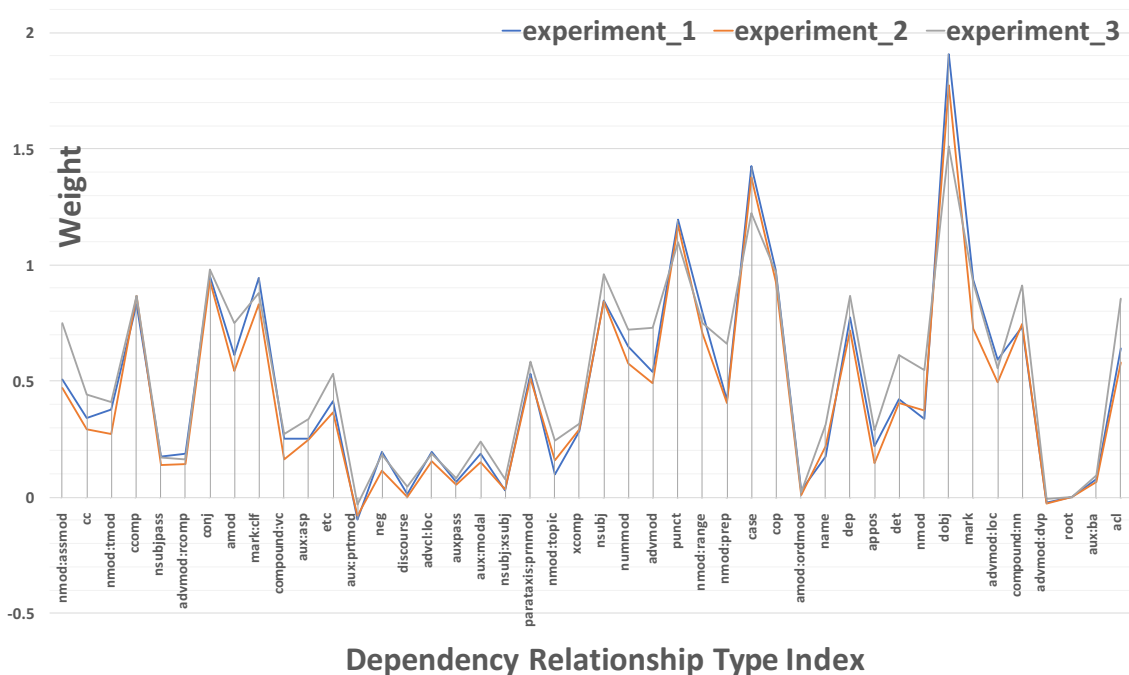

Figure 4: Three groups of trained weights. We do three experiments and plot three groups of trained weights. In the plot, x axis is the type of dependency relationship and y-axis is the trained weight.

relationship directly from dependency relationship.

5 Conclusion

In our paper, we propose Syntax Aware LSTM model for Chinese semantic role labeling. By SA-LSTM, we enable the network to benefit from higher level syntactic information. By assigning different weights to different kinds of dependency relationship, we find a stable and self-explanatory importance pattern. We push the state of the art F_1 to 79.60%. Even without pre-training or introducing any other extra semantically annotated resources, our SA-LSTM still outperforms the state of the art significantly based on Student's t-test.

References

- Danqi Chen and Christopher D Manning. 2014. A fast and accurate dependency parser using neural networks. In *EMNLP*. pages 740–750.
- Wenliang Chen, Yujie Zhang, and Hitoshi Isahara. 2006. An empirical study of chinese chunking. In *Proceedings of the COLING/ACL on Main conference poster sessions*. Association for Computational Linguistics, pages 97–104.
- Ronan Collobert and Jason Weston. 2008. A unified architecture for natural language processing: Deep neural networks with multitask learning. In *Proceedings of the 25th international conference on Machine learning*. ACM, pages 160–167.
- Weiwei Ding and Baobao Chang. 2008. Improving chinese semantic role classification with hierarchical feature selection strategy. In *Proceedings of the conference on empirical methods in natural language processing*. Association for Computational Linguistics, pages 324–333.
- Weiwei Ding and Baobao Chang. 2009. Word based chinese semantic role labeling with semantic chunking. *International Journal of Computer Processing Of Languages* 22(02n03):133–154.
- Daniel Gildea and Daniel Jurafsky. 2002. Automatic labeling of semantic roles. *Computational linguistics* 28(3):245–288.
- Tianshi Li, Qi Li, and BaoBao Chang. 2016. Improving chinese semantic role labeling with english proposition bank. In *China National Conference on Chinese Computational Linguistics*. Springer, pages 3–11.
- Joakim Nivre, Marie-Catherine de Marneffe, Filip Ginter, Yoav Goldberg, Jan Hajic, Christopher D Manning, Ryan McDonald, Slav Petrov, Sampo Pyysalo, Natalia Silveira, et al. 2016. Universal dependencies v1: A multilingual treebank collection. In *Proceedings of the 10th International Conference on Language Resources and Evaluation (LREC 2016)*. pages 1659–1666.
- Lei Sha, Sujian Li, Baobao Chang, Zhifang Sui, and Tingsong Jiang. 2016. [Capturing argument relationship for chinese semantic role labeling](#). In *Proceedings of the 2016 Conference on Empirical Methods in Natural Language Processing*. Association for Computational Linguistics, Austin, Texas, pages

- 2011–2016. <https://aclweb.org/anthology/D16-1212>.
- Honglin Sun and Daniel Jurafsky. 2004. Shallow semantic parsing of chinese. In *Proceedings of NAACL 2004*, pages 249–256.
- Weiwei Sun. 2010. Improving chinese semantic role labeling with rich syntactic features. In *Proceedings of the ACL 2010 conference short papers*. Association for Computational Linguistics, pages 168–172.
- Weiwei Sun, Zhifang Sui, Meng Wang, and Xin Wang. 2009. Chinese semantic role labeling with shallow parsing. In *Proceedings of the 2009 Conference on Empirical Methods in Natural Language Processing: Volume 3-Volume 3*. Association for Computational Linguistics, pages 1475–1483.
- Zhen Wang, Tingsong Jiang, Baobao Chang, and Zhifang Sui. 2015. Chinese semantic role labeling with bidirectional recurrent neural networks. In *EMNLP*, pages 1626–1631.
- Nianwen Xue. 2008. Labeling chinese predicates with semantic roles. *Computational linguistics* 34(2):225–255.
- Nianwen Xue and Martha Palmer. 2003. Annotating the propositions in the penn chinese treebank. In *Proceedings of the second SIGHAN workshop on Chinese language processing-Volume 17*. Association for Computational Linguistics, pages 47–54.
- Nianwen Xue and Martha Palmer. 2005. Automatic semantic role labeling for chinese verbs. In *IJCAI*. Citeseer, volume 5, pages 1160–1165.
- Haitong Yang, Chengqing Zong, et al. 2014. Multi-predicate semantic role labeling. In *EMNLP*, pages 363–373.
- Jie Zhou and Wei Xu. 2015. End-to-end learning of semantic role labeling using recurrent neural networks. In *Proceedings of the Annual Meeting of the Association for Computational Linguistics*.