

# Execution Integrity with In-Place Encryption

Dean Sullivan\*, Orlando Arias\*, David Gens<sup>†</sup>, Lucas Davi<sup>‡</sup>, Ahmad-Reza Sadeghi<sup>†</sup>, Yier Jin\*

\*University of Central Florida, USA

{dean.sullivan, oarias, yier.jin}@eecs.ucf.edu

<sup>†</sup>Technische Universität Darmstadt, Germany

{david.gens, ahmad.sadeghi}@trust.tu-darmstadt.de

<sup>‡</sup>University of Duisburg-Essen, Germany

{lucas.davi}@wiwinf.uni-due.de

**Abstract**—Instruction set randomization (ISR) was initially proposed with the main goal of countering code-injection attacks. However, ISR seems to have lost its appeal since code-injection attacks became less attractive because protection mechanisms such as data execution prevention (DEP) as well as code-reuse attacks became more prevalent.

In this paper, we show that ISR can be extended to also protect against code-reuse attacks while at the same time offering security guarantees similar to those of software diversity, control-flow integrity, and information hiding. We present *Scylla*, a scheme that deploys a new technique for in-place code encryption to hide the code layout of a randomized binary, and restricts the control flow to a benign execution path. This allows us to i) implicitly restrict control-flow targets to basic block entries *without* requiring the extraction of a control-flow graph, ii) achieve *execution integrity* within legitimate basic blocks, and iii) hide the underlying code layout under malicious read access to the program. Our analysis demonstrates that *Scylla* is capable of preventing state-of-the-art attacks such as just-in-time return-oriented programming (JIT-ROP) and crash-resistant oriented programming (CROP). We extensively evaluate our prototype implementation of *Scylla* and show feasible performance overhead. We also provide details on how this overhead can be significantly reduced with dedicated hardware support.

## I. INTRODUCTION

Instruction set randomization (ISR) [1], [2], [3], [4] is a countermeasure initially proposed with the objective of preventing code injection attacks. ISR provides a unique instruction set for every program by encrypting its underlying instructions at the binary level. This defense is effective against code injection because only properly encrypted instructions will execute on an ISR protected system. Rather than executing directly, injected code would first be decrypted and then executed. In practice, this results in an illegal instruction sequence being executed that causes the program to crash. With the onset of data execution prevention (DEP), however, code-injection style attacks became less practical. Instead, adversaries shifted to code-reuse attacks (CRAs) as their primary method of exploitation.

Rather than executing injected code, CRAs craft malicious computations by stitching together code chunks (gadgets) already resident in the executable segments of a process. ISR is not an effective defense against CRAs because its payload has already been correctly encrypted. Malicious reuse of existing instructions in an ISR protected application results in the correct decryption and execution of those instructions.

To make matters worse, CRAs are not easily prevented as recent research [5], [6], [7], [8], [9], [10], [11], [12], [13] has demonstrated. These attacks are capable of bypassing state-of-the-art protections, including address-space layout randomization [14], Google’s IFCC [15], and Microsoft’s EMET [16].

Prior defenses aimed at preventing CRAs can be loosely categorized into software diversity [17], [18], [19], control-flow integrity [20], [21], and information hiding [22], [23], [24], [25]. Software diversity attempts to prevent the adversary from learning the code or data layout of a program by randomizing program segments, such as the base address of shared libraries [14]. Control-flow integrity limits the attacker from arbitrarily manipulating the instruction pointer by checking that every transfer aligns with a pre-computed control-flow graph of the program [26]. Code Pointer Integrity (CPI) and information hiding techniques attempt to prevent leakage of code or data by isolating sensitive structures, such as code pointers or executable pages in protected memory regions [25], [18]. However, as we elaborate in Section IX, each of these defense strategies have their strengths and weaknesses. Until now, there exists no proposal that unifies their individual strengths into one framework to tackle the threat of code-reuse attacks.

**Goals and Contributions.** In this paper, we present *Scylla*, a defense that updates ISR to provide measurable protection against code-reuse attacks. It combines the salient features of software diversity, control-flow integrity, and information hiding approaches to reliably protect against adversaries that reuse or disclose the code layout of a vulnerable application. The core feature of *Scylla* is a new form of ISR that combines fine-grain code diversification with per-basic-block encryption to hide the code layout of a randomized binary, while at the same time restricting control flow to a benign execution path. This allows us to achieve what we call *execution integrity* within legitimate basic blocks. Execution integrity offers protection similar to coarse-grain control-flow integrity without the need to statically or dynamically compute a control-flow graph. *Scylla* also affords complete read-access to a vulnerable program without revealing the underlying code, due to per-basic-block encryption, or its layout due to basic block diversification. To the best of our knowledge, *Scylla* is the first defense that demonstrates how ISR can be extended to protect

against code-reuse attacks.

In summary, we make the following contributions:

- **Per-Basic-Block ISR:** we present a new form of ISR that offers protection against CRAs and prevents disclosure of the underlying code layout, including its information and control flow, under complete read-access to the program.
- **Execution Integrity:** we present a novel and practical protection technique to prevent an adversary from hijacking benign control flow.
- **Prototype Implementation:** we provide a fully-working prototype implementation for x86\_64 systems that is also capable of handling shared libraries.
- **Extensive Evaluation:** we provide an extensive security and performance evaluation. We show that Scylla is resilient to traditional ROP, JIT-ROP [5], CFB [9], [8], and CROP [6]. Our performance measurements show that our system only incurs 20% overhead, despite the complexity of Scylla’s hybrid defense. We also discuss hardware extensions in Section VIII to further reduce the overhead.

## II. INSTRUCTION SET RANDOMIZATION

Instruction Set Randomization (ISR) was initially proposed by Gaurav et al [1] with the objective of countering code-injection attacks. A static key is utilized to encrypt the entire binary, which is stored as part of the header of the executable file and loaded into the kernel. Subsequent accesses to the key are done by the operating system only.

To account for possible deficiencies in utilizing a single key per cipher block, another ISR approach was proposed by Barrantes et al in [2] that utilizes a one time pad (OTP) to encrypt memory. The OTP key is generated by a random number generator. Although the platform can be exploited by disclosing the unprotected key file, the work presented by Sovarel et al in [27] demonstrates a stronger attack by showing that it is only necessary to obtain the key for some parts of the memory to compromise the entire system.

The system in [2] was extended by Portokalidis et al in [4] to add support for dynamic libraries, key management, and forgoes the utilization of an emulator, opting instead to use Intel’s PIN tool. Memory protection is added for writes to avoid an attacker overriding the callbacks used by PIN in order to leak information or obtain arbitrary code execution in the system. Memory reads are not protected, allowing for encrypted page leakage and key leakage at runtime.

Since previous software based approaches exhibited large performance overhead a hardware-supported solution, called ASIST [28], was presented to overcome this. They demonstrated a significant reduction in performance, only 1.5% on average, with minimal additional hardware.

**Updating ISR for Code-Reuse Attacks.** We note that past ISR defenses were designed with the prevention of code injection attacks in mind. They do not prevent code-reuse attacks as control flow can be redirected to any encrypted instruction and it will be decrypted correctly. In this work we

improve upon ISR by encrypting a program in basic blocks, which allows us to implicitly enforce coarse-grained control-flow integrity.

## III. THREAT MODEL

We assume an adversary equipped with a memory corruption vulnerability, which allows arbitrary read operations to any mapped memory page of the process. We also allow the attacker to perform arbitrary writes to the data space of the process. We do not allow the modification or injection of code in memory as we assume code to be protected through DEP [29]. We also assume the attacker has access to an unprotected binary as a reference, but does not know the in-memory code layout of the executing victim process partly due to ASLR [14], but also because of Scylla’s protection.

We assume that the attacker’s goal is to statically or dynamically reveal code pages to discover the code layout and craft a code-reuse attack. The attacker can follow code pointer references in the application’s data memory, dynamic linking segments such as the global offset table (GOT) or through the dynamic disassembly of code pages. We consider a successful attack against Scylla to be one that reliably discloses the diversification secrets. The attacker can then use the secrets to hijack the program’s control flow for malicious purposes, such as disabling DEP to execute injected code. We do not consider data-flow based attacks, wherein the attacker modifies key pieces of data in memory to obtain an alternate but legal control flow.

To summarize, our threat model is in line with previous research on ISR, but additionally considers the important class of code-reuse attacks as its main defense target.

## IV. SCYLLA DESIGN

Scylla extends Instruction Set Randomization (ISR) to protect against code-reuse attacks. Classic ISR was designed with code injection attacks in mind. The design does not readily translate to protecting against code-reuse attacks (CRA), since instructions under classic ISR are decrypted correctly regardless of their position in program code. Scylla, therefore, incorporates the notion of an execution path within a basic block.<sup>1</sup> In particular, each instruction within a basic block is decrypted with respect to its predecessors. This guarantees sequential execution from a basic block’s unique entry to its unique exit. We call this protection *execution integrity*. Scylla further addresses known plain-text to cipher-text attacks, of which past ISR approaches were vulnerable [27], by diversifying the code layout.

Scylla protects applications from code layout disclosure, recovery of the program’s underlying information and control flow, and control flow hijacking. Scylla applies fine-grained code diversification by permuting functions [30] and basic blocks [31] within functions, as well as inserting dummy instructions [32] to prevent disclosure of the program’s layout in memory. To hide the program’s underlying information and

<sup>1</sup>We consider a basic block to be any sequential code sequence with a unique entry and unique exit and use this definition throughout the paper.

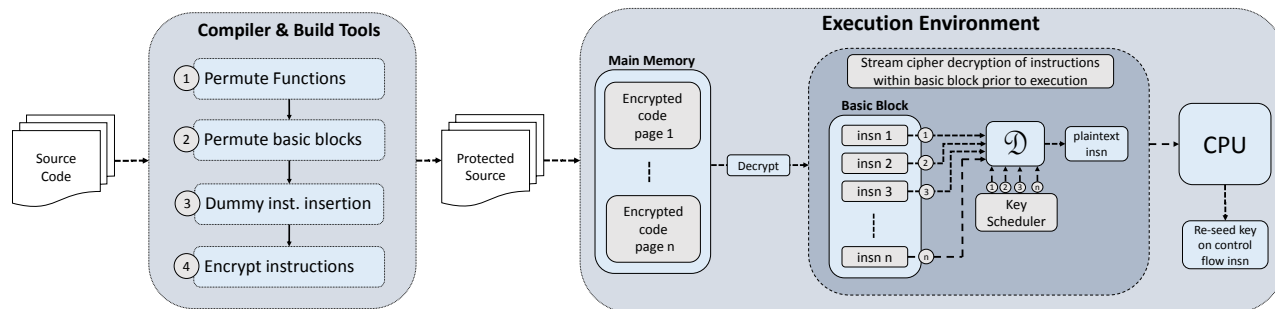

Fig. 1: System overview. Our compiler and build-tools generate a diversified application using function and basic block permutation, as well as dummy instruction insertion. The code is then encrypted using a stream cipher over basic blocks. In the execution environment, code pages are always encrypted in memory. Basic blocks are decrypted live before being forwarded to the CPU.

control flow, Scylla encrypts all code pages utilizing a stream cipher over every basic block in the program. Instructions are decrypted as they are scheduled to be executed, closing the threat of dynamic disassembly via an attacker controlled arbitrary read. Implicit control-flow integrity, or execution integrity, is supported by implementing per-basic-block encryption which constrains control flow to function and basic block entries.

Figure 1 shows the major design components of Scylla. The program is first diversified by permuting the locations of functions in the code segment. Then, basic blocks inside functions are permuted and dummy instructions inserted into those basic blocks. After diversifying the application, we encrypt every basic block using a stream cipher. The execution environment ensures that the protected application is always encrypted in memory. Encrypted instructions scheduled for execution are decrypted using the stream cipher as they enter the CPU. Plain-text instructions are forwarded to the CPU and execute normally. Decrypted instructions are never written back to memory and read access to code pages return cipher-text. We describe each component in detail below.

**Fine Grained Code Randomization:** Scylla combines several diversification techniques to complement in-place code encryption. In the following we explain how we combine function permutation, basic block reordering, and the insertion of dummy instructions to diversify the binary layout of the protected program. While all of these techniques have been previously proposed [17], [31], [33], combining them is challenging and has not been done before.

First, we permute function locations to hinder disclosure attacks that reveal the program’s layout by reading code pointers in data pages. Usually, an adversary with arbitrary read capabilities is able to correlate code pointers with target instructions. By leveraging function permutation, we reduce this capability of the attacker to guessing.

Second, we permute basic blocks within functions to conceal the function layout. This has two effects: on the one hand, it increases the complexity of our diversification by adding another layer of randomization. On the other hand, this protects the encrypted program from known plain-text attacks. For instance, if a function entry is discovered the attacker can

correlate the encrypted instructions against her local copy to compute the key. However, this cannot be achieved without knowledge of the basic block ordering.

Third, we randomly distribute dummy instructions within basic blocks, altering address offsets and instruction ordering within a basic block. Dummy instruction insertion also complements Scylla’s encryption mechanism by concatenating a random string to the program. In this case, the type (i.e., *mov*, *add*, *push/pop*, *nop*), number, and distribution of inserted instructions within a basic block make-up the random string.

The security guarantees offered by Scylla are not tied to diversification alone, but to the combination of randomization with per-basic-block encryption. Disclosure of a single, or several, function or basic block entries does not reveal the surrounding code layout when the program is diversified. However, an adversary can recover portions of the code layout, or even the whole code layout, by exploiting the techniques described in Section IX. In this case, per-basic-block code encryption complements diversification by ensuring that the control flow of the program can only target valid basic block entries and that the code residing at the disclosed addresses remains concealed as cipher-text.

**Per-Basic-Block Instruction Encryption:** After randomizing the binary, we encrypt the program to hide the underlying code layout and enforce execution integrity. The purpose of this additional protection is to force the control flow to the unique entry and exit points of a basic block to prevent control flow hijacking. In particular, Scylla encrypts every basic block in the program using a stream cipher. This guarantees that in order to correctly decrypt and execute the application, control flow must target the unique entry point of a basic block and execute sequentially to its terminating control flow instruction. This form of implicit control flow integrity due to Scylla’s encryption method is what we have called *execution integrity*. Scylla’s encryption combined with diversification also protects against disclosure because reading the code location does not reveal any other information about the surrounding code layout. In fact, an adversary would need to break the underlying encryption to reveal the program’s in-memory layout, as directly reading code pages only returns cipher-text.

**Runtime Decryption:** As depicted in Figure 1, instructions are decrypted as they are fetched by the CPU. This ensures that no instruction is ever in plain-text in main memory or any of level of the shared cache hierarchy. When a control flow instruction is encountered, the execution environment reseeds the stream cipher for the next basic block. Scylla’s execution environment guarantees that the underlying code layout, including its information and control flow, remains hidden from an adversary. Hijacking control flow must occur along existing control flow paths within the program in order to decrypt instructions correctly.

## V. ARCHITECTURE

In the following, we describe our architecture for Scylla’s fine-grained randomization and code encryption mechanism in detail. To randomize the binary, we modify the LLVM compiler infrastructure [15] to generate a diversified program that supports per-basic-block instruction encryption by permuting functions, reordering basic blocks within functions, and randomly distributing dummy instructions within basic blocks. We note that source code is not a strong requirement for randomization, and that similar diversification techniques have already been applied at the binary level [31], [34]. However, for our proof-of-concept we chose to leverage the extensive functionality of LLVM for program transformation and ease of implementation. For Scylla’s encryption mechanism, we extend standard tools for binary manipulation on Linux.

**Fine Grained Code Randomization:** We permute functions, and then basic blocks within functions, to improve the cache pressure that might otherwise be incurred if basic blocks were randomly distributed across the entire executable. Although this reduces the entropy of the randomization, we reason that this decision does not sacrifice security. In Section VI we demonstrate that the number of possible permutations using the SPEC CPU2006 benchmark suite [35] is sufficiently high to prevent an adversary from revealing the code layout.

We randomly distribute dummy instructions within basic blocks in the program by selecting from `nop` instructions, instruction that move a register onto itself, arithmetic and logic instruction with an identity element, and pushing and popping a register from the stack. We include this diversification technique to prevent cipher-text only and known plain-text attacks to which past ISR approaches have been susceptible [27]. Launching such an attack against Scylla after dummy instruction insertion requires an adversary to know the number, distribution, and type of dummy instructions inserted within the basic block.

**Encrypting Code Pages: Creating a Scylla binary:** Encryption in our Scylla prototype uses an extended `objcopy` program, part of the GNU `binutils` toolset. Normally, `objcopy` is used to copy and translate object files between different formats. We extend its functionality to output encrypted executables using a stream cipher. We gate this functionality with a command line option. When active, code pages are disassembled as they are copied using `libopcode` as

the backend for disassembly. Basic blocks are then encrypted using a stream cipher and the encrypted code is written to a new executable.

Our modified `objcopy` stores the seeds used in the stream cipher and the cipher permutation in a new section of the binary. This section, named `.encseeds`, is flagged as non-allocatable, which means that the loader will not store it in memory. Our execution environment (see Section V) utilizes the information within this section to decrypt the binary live as it runs.

Scylla’s encryption capabilities facilitate our principle of *execution integrity* by ensuring that instructions are executed in the way they were intended. This is achieved by encrypting every instruction with respect to its predecessor using a stream cipher; the first instruction in a basic block chain is encrypted with respect to a seed. Previous code encryption approaches encrypt code pages regardless of instruction sequences and were therefore unable to protect against code reuse attacks.

Scylla’s encryption model applies to standalone, well-formed basic blocks. This is deliberate in order to avoid whole program analysis and recovery of a program’s complete execution path in order to correctly manage encryption keys. Instead, Scylla circumvents this and simplifies key management by using a single key to encrypt the first instruction at a control flow target. This simplification has the side-effect of allowing Scylla to implicitly handle problematic code constructs, including calls to library functions and signal handlers, e.g., by using key initialization on basic block entry. Scylla does not currently support JIT code generation.

Each encryption chain is terminated when a control flow instruction is encountered. For alignment purposes, compilers may issue dummy instructions as padding at the end of a function. As such, the entry point of an ensuing function may not immediately follow a control flow instruction. To avoid missed basic blocks during the encryption process, we have `objcopy` read the symbol table of the executable and look for function entries, and encrypt them to ensure correctness in the process.

*Key Generation:* For our prototype implementation, we utilize a pseudo-random number generator (PRNG) to generate a key stream for our stream cypher. We utilize the Advanced Encryption Standard in Counter Mode (AES-CM) to generate keys. Since the largest acceptable x86\_64 instruction at the time of writing is 15 bytes wide, we utilize AES-CM with a 128 bit block size and ignore the uppermost byte for the encryption of instructions. AES-CM proves to be sufficiently resilient for our purposes. We seed the AES-CM engine with a key and initialization vector on every basic block entry. Our counter function is a simple increment by one.

**Runtime Wrapper:** To the best of our knowledge, there is no commercially available platform capable of decrypting instructions as they are executed. In prior instruction set randomization schemes [1], [2], [3], [4] dynamic binary instrumentation tools, such as Dynamic RIO or Intel PIN, have been used to perform live decryption. However, Dynamic RIO and

Intel PIN share their own address space with the binary they are instrumenting. Under our attacker model, this means that the diversification and encryption secrets can be directly leaked using memory disclosures. Although these disclosures can be prevented by checking the locations from where a memory read is taking place, it would not be a realistic emulation of the necessary hardware to accomplish the task of runtime decryption.

System emulators such as QEMU or MARSSx86 are possible alternatives to the implementation, but come with their own set of challenges. These tools act as hypervisors and as such come with the requirement of a guest operating system. Coupled with this requirement is the need to handle multitasking and applications that do not support our scheme. As such, a great deal of modification would be required for a testing platform based on these tools. QEMU is capable of running applications emulating a full system’s user land without the requirement of a guest operating system. However, when used this way, it translates the guest program’s instructions to native code and caches it in a set of translation blocks. Although this technique is used to improve runtime performance, it would be in direct violation of our requirement of keeping all code pages encrypted in memory.

Consequently, we developed a prototype simulator for Scylla which closely resembles our proposed hardware model. The simulator consists of three major components: a Launcher, Monitor, and Encrypted Process. When invoking the simulator, the Launcher process runs first. The Launcher reads the contents of the `.encseeds` section and obtains the seeds for the stream cipher and the permutation applied to it. At this point, the Launcher spawns a child process which requests to be traced using the `ptrace()` facilities of the Linux kernel. The child then spawns the Encrypted Process and waits for the parent, which has been converted to a Monitor. The Monitor process proceeds to trace the execution of the Encrypted Process until the latter terminates.

Algorithm 1 delineates the operation of the Monitor process. As long as the Encrypted Process is in a runnable state, the Monitor obtains the program counter of the child and fetches 15 bytes from that address into a local buffer. If the last instruction executed by the Encrypted Process was a control flow instruction, the Monitor reseeds the stream cipher with information obtained from the Loader process, otherwise, the Monitor forwards the stream cipher to the next state. The data stored in the local buffer is then decrypted using a key obtained from the stream cipher. The Monitor decodes the instruction while keeping record of the instruction type, and writes the decrypted instruction to the Encrypted Process’ code segment at the location of the program counter and singlesteps it. This allows the Encrypted Process to execute one instruction at a time. The Monitor then writes back the encrypted buffer into the Encrypted Process as it would otherwise leave portions of code as plain-text in memory.

Our simulator closely resembles the operations a hardware-based implementation would take. In a Linux-based system, the kernel reads the sections of an executable and allocates

---

**Algorithm 1** Monitor process operation. The Monitor Process singlesteps through the Encrypted Process decrypting instructions as they are about to be executed.

---

```

1: while child is running do
2:    $pc \leftarrow child\%rip$ 
3:    $buf \leftarrow child.\text{text} @ pc$ 
4:   if last isns is cflow then
5:     Reseed stream cipher
6:   else
7:     Forward stream cipher
8:   end if
9:    $buf \leftarrow buf \oplus key$ 
10:  Decode instruction
11:   $child.\text{text} @ pc \leftarrow insn$ 
12:  Singlestep child
13:   $buf \leftarrow buf \oplus key$ 
14:   $child.\text{text} @ pc \leftarrow buf$ 
15: end while

```

---

them in memory as needed. The kernel can be extended to perform the tasks of our Loader process. Load-time encryption can be achieved by extending the kernel loader. The Monitor process simulates a combination of a hardware decryption unit and kernel process manager. As instructions are fetched, they are decrypted using the stream cipher by a hardware module in the front-end. This hardware module handles, in conjunction with the kernel, context switches and multitasking. Much like in our execution wrapper model, the Encrypted Process is unable to leak secrets from the Monitor because a hardware-based model keeps the secrets by enforcing memory separation.

Since our simulator runs as a user space process, we provide support for dynamic linking by exploiting the workings of the dynamic loader in UNIX-based systems. Before launching the encrypted application, we set the `LD_LIBRARY_PATH` environment variable in the child process and point it to a path where the encrypted libraries reside. The child application also requests an encrypted resolver. A library function call proceeds in much the same fashion as in a normal system. The resolver gives priority to the encrypted libraries located in the directory specified by `LD_LIBRARY_PATH`. The only information that is needed are the seeds used by the stream cipher to decrypt the library and loader information. This is obtained from the `.encseeds` section of the object files. We then tie the seeds to the address range of the library and allow execution to proceed as normal. As such, encrypted libraries can be freely shared across applications that use them in a rich operating system environment.

The simulator also allows us to monitor other aspects of the child process, such as the time that was spent during execution, and the stream of instructions being executed. We profile a set of applications from the SPEC CPU2006 benchmark and discuss results in Section VIII.

## VI. SECURITY EVALUATION

We perform our security evaluation assuming that the attacker’s goal is to disassemble enough code pages, or infer enough code locations, to craft a code-reuse attack (CRA). As such, we analyze and evaluate the effectiveness of our scheme in relation to an adversary equipped with a memory vulnerability that allows disclosure of the program’s address space and the ability to arbitrarily redirect control flow of a program to any chosen target. This is in line with recent work [31], [36], [25], [18], [37]. Following standard cryptographic protocols, we assume that the attacker knows the workings of the underlying implementation of our stream cipher, but does not know the keys and IVs used to seed the pseudorandom number generator.

**Code-Reuse Attack Payload:** As mentioned in Section III, we assume that the attacker cannot modify or inject code in memory due to data execution prevention (DEP). Because of this, almost all real-world CRAs aim at disabling DEP and launch a code-injection attack thereafter. Particularly, we assume an adversary, who is equipped with a memory-disclosure vulnerability. Usually, this allows bypassing even fine-grain diversification and chaining function or basic block gadgets to construct an attack that disables DEP. However, to bypass Scylla, the attacker would still need to break the per-basic-block encryption to perform useful operations within the process. Scylla provides built-in protection in this scenario because it always expects to decrypt encrypted instructions. This holds despite the permissions of the process.

**Traditional ROP:** Traditional ROP utilizes known gadgets in the program’s code and chains them either using a dispatcher gadget, as in the case of jump-oriented programming [38], [39], or by corrupting return addresses found on the stack [40]. Gadgets are any sequence of instructions found within basic blocks that end with an indirect branch instruction. Because the x86\_64 instruction set allows unaligned instructions, gadgets need not be made of intended instructions but can be made from partially decoded instructions.

Scylla protects against control flow redirection to arbitrary instructions inside a basic block. This is achieved by encrypting basic blocks with a stream cipher until the terminating control flow instruction on the basic block is found. During encryption, as new instructions are encountered in the basic block, the key scheduler is forwarded and a new key is utilized to encrypt the instruction. During execution, when a new basic block is entered, instructions are decrypted in a similar fashion. Redirecting control flow to the middle of a basic block results in instructions being decrypted with the wrong key. This results in the CPU executing instructions in a pseudostochastic fashion that eventually causes the program to crash. Previous analysis demonstrates that an average of four to five instructions is sufficient to terminate a process [2].

An attacker who intends to perform a traditional ROP attack would need to reverse the stream cipher in order for malicious control flow redirection to work. With our usage of AES-CM, the attacker must know the secret key and initialization vector

used to seed the AES engine in order to deduce the keys for decryption. Our usage of AES-CM ensures sufficiently secure pseudorandom numbers to encrypt a program in memory.

**Control-Flow Bending:** Control-flow Bending [9] (CFB) is a recent attack that bypasses CFI protection assuming an ideal CFI policy is in place with relaxations in the enforced control flow graph. In a CFB attack, an adversary corrupts a code pointer to call a valid function entry, as determined by the CFI policy. The callee must also contain a vulnerability which allows the attacker to corrupt the return address, pointing to any call-preceded site. This allows the attacker to bend control flow maliciously and craft any arbitrary exploit. However, Scylla employs fine-grained diversification with per-basic-block code encryption to prevent the attacker from locating call-preceded targets. This attack further requires the adversary to locate a vulnerable function in the program allowing her to overwrite a return address. As discussed, our protection efficiently prevents knowledge of the underlying information and control flow of the program as well as its code layout due to the combination of fine-grain code diversification with per-basic block encryption.

**JIT-ROP:** JIT-ROP [5] is a powerful class of attacks against fine-grained randomization techniques. In particular, these attacks exploit the disclosure of a single code pointer to adjust their ROP payload to the randomized program layout and gadget search space at runtime. This enables an adversary to also defeat load-time based defense approaches that re-randomize the application program space layout per execution. We discuss the two main types of JIT-ROP and how they are handled by Scylla.

Conventional JIT-ROP [5] disassembles code pages while keeping a collection of gadgets found during disassembly. Any code pointer, as part of a direct call or a direct jump, is used to find new code pages, bypassing the diversification applied to the program. However, under Scylla, any read performed from a code page yields cipher-text. Although the code page itself is readable, it cannot be readily disassembled without being able to break the encryption. As such, an attacker is unable to utilize conventional JIT-ROP to disclose new code pages or find gadgets in the binary.

JIT-ROP can be extended to use only code pointers disclosed from data pages, or indirect disclosure, as the pivot point to start a disassembly chain of code pages [41]. Although Scylla does not fully protect against indirect disclosure, it does prevent disclosure of the entire program due to the underlying encryption. Scylla’s protection prevents such a vulnerability from revealing the surrounding code layout because of fine-grain code diversification combined with per-basic-block encryption.

The indirect disclosure of function entries or basic blocks provides the attacker with potential gadget locations inside basic blocks. To tackle this type of disclosure, other approaches such as Readactor [18] utilize trampolines to hide the location of basic blocks, eliminating any indirect disclosures of gadgets inside them. Scylla, on the other hand, prevents the usage of

those gadgets via execution integrity. Arbitrary redirection of control flow to gadgets within a basic block results in the execution of incorrectly decrypted instructions, causing the program to crash. As such, Scylla is able to forgo the usage of trampolines and the separation of code from data. Furthermore, an attacker who discloses a basic block is faced with the same problem encountered when attempting to disclose new code pages with conventional JIT-ROP, breaking the encryption. We show that this requires knowledge of the secrets behind the key scheduler, which proves to be infeasible as described in Section VII.

For future work, we plan to extend our protection mechanism to better conceal code pointers in memory to avoid indirect memory disclosure. Scylla could be extended to encrypt vtable pointers and vtables and decrypting them as they are about to be used. Furthermore, we will investigate novel ways to perform load time randomization of binaries and more efficient methods to encrypt instructions in memory.

**Crash-Resistant Oriented Programming:** Crash Resistant Oriented Programming (CROP) [6] is a powerful attack capable of bypassing fine-grained randomization, information hiding, and control-flow integrity protection on client-side applications. This attack exploits mishandled exception handling and system call behavior to scan memory without crashing, transforming these crash resistant primitives into so called *memory oracles* allowing the adversary to infer accessible memory boundaries. Combining these two techniques, the authors demonstrate the ability to locate unreachable memory regions such as the thread and process environment block in Windows systems, reference-less memory regions such as the safe regions in code-pointer integrity (CPI) [25], subvert hidden code pages by locating export symbols or trampolines addresses used in Readactor [18], and discover functions or valid return targets within a control flow path.

Although Scylla does not prevent an attacker from reading code pages using a memory oracle, any reads performed from code pages return cipher-text. Due to both the key permutation and code diversification techniques offered by our protection, correlating plain-text to cipher-text is infeasible. It could be reasoned that an attacker could use a crash-resistant memory oracle to redirect control flow into the cipher-text to locate valid control flow targets. However, the memory oracles used in CROP are only resistant to crashes from segmentation faults. Memory oracles do not handle bus errors or illegal instruction faults, which are the main causes of program termination under Scylla’s protection when unintended instruction sequences are executed.

**Comparison with Binary CFI:** Our goal is to protect an application against sophisticated code-reuse attacks through an instrumentation on the *binary* level. This means that Scylla does not require the source code of the protected program and is applicable to a large range of software. While for our proof-of-concept solution we chose to diversify programs using the LLVM compiler for ease of implementation, source code is not a strong requirement [31], [34]. Furthermore, even

though control-flow integrity (CFI) [26] was initially proposed as a compiler extension, this has been extended to the binary level as well [42], [20]. However, these extensions have been shown to be vulnerable to attacks because of their relaxed CFI policies [12], [43], [44]. These policies are due to the inherent difficulty of reconstructing an accurate control flow graph (CFG) of a program from its binary representation.

Our approach improves upon the inherent limitations of binary CFI schemes, because Scylla does not require a CFG of the protected program as input. Instead, we protect the application through a combination of per-basic-block encryption and randomization to restrict program execution to the intended path at runtime. More importantly, our security guarantees do not depend on the asserted precision of such a graph.

Similar to other defenses deployed on the binary level, we do not cover attacks such as counterfeit object-oriented programming (COOP) [11], or whole-function reuse at the moment. However, we are currently investigating the possibilities of offering a protection against these kinds of attacks within our scheme with added vtable and function protection through trampolines, as proposed by Readactor++ [37].

## VII. ANALYSIS OF ENCRYPTION AND DIVERSIFICATION

**Probability of Guessing Basic Blocks:** Encrypting basic blocks using a stream cipher provides an adversary with the possibility of maliciously chaining the execution of basic blocks. To maliciously chain execution, an attacker must disclose the location of the necessary basic blocks. Thus, we focus on the probability of an attacker locating a chosen basic block.

Scylla randomizes the layout of a binary and then applies encryption over basic blocks, which provides protection against direct disclosure of code. An attacker reading from code is only able to obtain cipher-text and has no knowledge of the underlying instruction stream because of the randomization. For our prototype, we ensure that the layout of the resulting binary differs substantially throughout different compilations. Because we randomize function locations and reorder basic blocks within a given binary, the amount of entropy directly depends on the number of functions and basic blocks in a binary.

We reason that by performing direct disclosures of code pages, an attacker would theoretically be able to locate an individual basic block with a probability of  $1/\sum_{i=1}^m n_i$  where  $m$  is the number of functions in a program and  $n_i$  the number of basic blocks in function  $i$ . Load-time randomization for a process of  $m$  functions and  $n_i$  basic blocks in function  $i$  provides the maximum theoretical entropy for our randomization scheme, given by  $(\sum_{i=1}^m n_i)!$ . However, cache locality is lost during execution and a higher penalty is paid in performance because of the distribution of basic blocks under this randomization scheme. We find that this is unnecessary, as we are still able to obtain a large amount of entropy without significantly degrading cache performance by randomizing function locations and positions of basic blocks



within them. The entropy provided under this scheme is given by  $m! \times \prod_{i=1}^m n_i!$ .

Therefore, in practice, the probability of an adversary locating an individual basic block through direct disclosure can be estimated as  $1/(n_{av} \times m)$ , where  $m$  is the number of functions, and  $n_{av}$  is the average number of basic blocks per functions. Using data obtained from the SPEC CPU2006 benchmarks, Table I, we compute the probability of finding a basic block and correlate it to the size of the code space of the benchmarks. This is shown in Figure 2. As expected, the probability of guessing a particular basic block decreases as the size of the code segment increases. Generally speaking, larger binaries will contain a higher number of basic blocks. An attacker exploiting a large binary with a small number of basic blocks will be faced with basic blocks that have large side effects, which is detrimental to a CRA.

Name	Mean #BB/FN	#FN	Size in Bytes
astar	7.5	213	55K
bzip2	28.5	100	94K
gcc	30	5577	3.3M
gobmk	11.65	2679	3.8M
h264ref	35.33	590	609K
hmmer	21	538	348K
libquant	10	115	82K
mcf	21.74	24	62K
omnetpp	4.35	602	885K
sjeng	39.8	144	182K
xalan	6	5653	8.2M

TABLE I: SPEC2006 basic block statistics. *Mean #BB/FN* denotes the average number of basic blocks per function. *#FN* denotes the number of functions in the binary. The number of permutation for function shuffling combined with per function basic block randomization is computed as  $m! \times \prod_{i=1}^m n_i!$ , where  $m$  is the number of functions and  $n$  is the number of basic blocks.

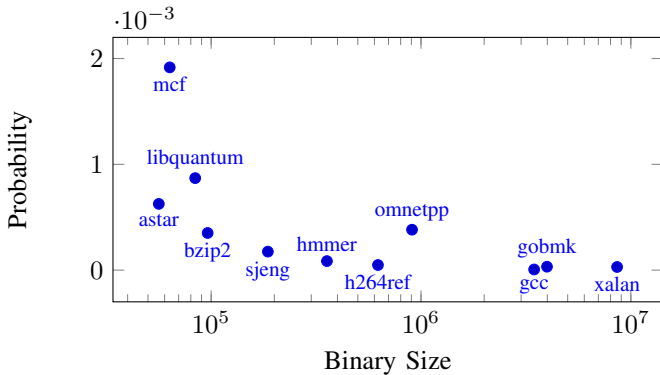

Fig. 2: Probability of disclosing function and basic block entries.

Scylla also provides a mechanism to keep similar basic blocks from being identified by inserting dummy instructions

within basic blocks, then encrypting them. This provides an extra layer of obfuscation against direct direct memory disclosure because the original program has effectively been concatenated with a random string. With dummy instructions inserted into a program an attacker is unable to perform frequency analysis in leaked cipher-texts to identify basic blocks, or perform known plain-text attacks without first knowing their distribution.

*Attacker Obtains A Basic Block* We now discuss the effects of the attacker being able to obtain a basic block. Although this is not possible using direct disclosure of a code pointer, an attacker may still be able to obtain some manner of basic block information by disclosing code pointers such as those found in the GOT, vtables or return addresses stored in the stack. We perform an analysis of what can be done with this information under two circumstances: the attacker does not have matching plain-text, and the attacker has a matching plain-text.

*Attacker does not have matching plain-text:* An attacker who obtains cipher-text, but does not have matching plain-text may attempt to study the behavior of the program by altering a code pointer to force execution from an adjacent location. Upon executing this new code path, the decryption mechanism will return incorrect instructions. The attacker can then observe any side effects caused by this execution path [27]. Previously reported experimental data shows that the probability of a meaningful computation under this conditions is small and that the program will likely crash due to an illegal memory access or illegal instruction [2].

Furthermore, this type of attack is only reliable if the program is respawned with the exact randomization features as before, such as when naively cloning code and data pages from a parent process without re-encrypting and re-randomizing them. If the newly loaded code pages use a new seed and key, then the attacker is unable to perform side-channel analysis under this scenario.

*Attacker has matching plain-text* The assumption that an attacker has a matching plain-text is not unsound. If the disclosed code pointer is a vtable entry or a GOT entry, for example, then the attacker can disclose the entry basic block to a function. The attacker can then attempt to utilize a plaintext copy of the binary to obtain the encryption secrets.

Under these conditions, the attacker is able to obtain  $n$  bits of the key by performing a bitwise XOR between the first  $n$  bits of the encrypted block and the first plaintext instruction in the basic block. The attacker may then attempt to find the rest of the keys on a basic block by performing subsequent decryption operations. Using this information, an attacker can iteratively attempt to reverse the secrets behind the stream cipher until reaching the basic block's terminating control flow instruction and obtain its target address. We randomly distribute a permutation of dummy instructions within basic blocks to effectively counter this attack by concatenating a random string to the plain-text and then generating the cipher-text.



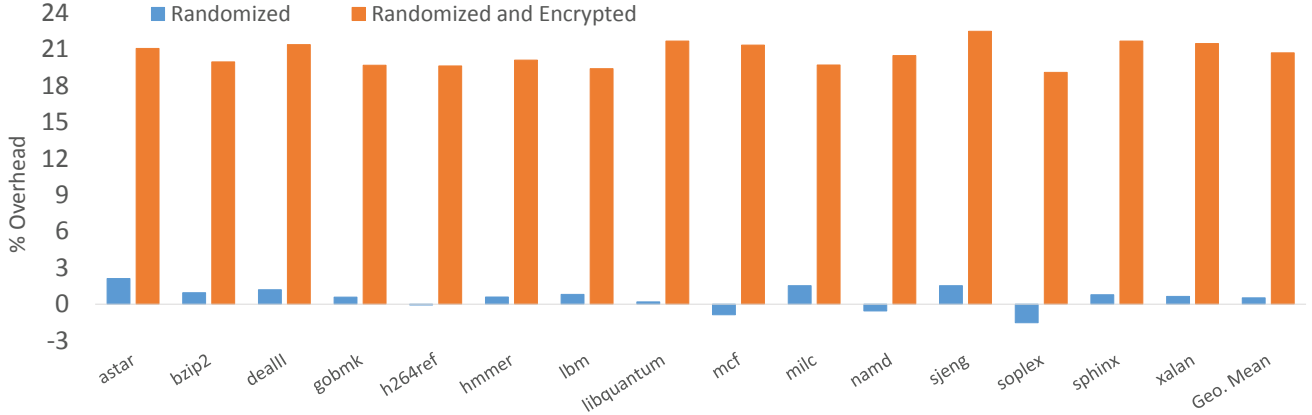

Fig. 3: SPEC CPU2006 performance results.

If a predictable key scheduler is used the attacker can potentially use this information to guess the next key given dummy instruction insertion. Dummy instructions, such as `nop` sleds or moving a register onto itself, can be detected by the attacker since the key obtained from performing a bitwise XOR between the plain-text instruction and cipher-text instruction would not match the expected key. An attacker can decrypt the entire basic block until reaching the terminating control flow instruction. At this point, the target address can be decrypted and a new decryption chain started. This process is, in effect, an extension to JIT-ROP [5] to discover code pages by decrypting instructions when using a predictive key scheduler. However, relying on a cryptographically secure pseudorandom number generator for key generation ensures that this type of attack is infeasible.

### VIII. PERFORMANCE EVALUATION

To evaluate the performance impact of Scylla, we use the SPEC CPU2006 benchmark suite which contains a set of representative CPU-intensive programs seen in real-world applications. We use Arch Linux with Linux kernel version 4.8.4 for our evaluation running on an Intel Core i7-2600 CPU clocked at 3.4GHz, with a 32KiB L1 I/D cache, 8MiB of L3 cache, and 16GB of RAM. We use Scylla’s modified LLVM compiler to build SPEC with `musl-libc` and `libc++`, rather than `glibc` and `stdlibc++`, because LLVM does not currently support `glibc` and `stdlibc++` library extensions. We statically link these libraries for our evaluation, but this is not a requirement as Scylla initializes a key on every basic block entry which includes entry into library functions. Because of this we were unable to build the `perlbench` and `gcc` benchmarks as these rely on internals and extensions provided only by `glibc`.

We evaluated the compatible benchmarks against native execution with both fine-grain diversification only, and with both diversification and per-basic-block encryption. Each benchmark is executed within our execution wrapper and evaluated by measuring the time taken to execute 250 million instruc-

tions. We limit the instruction count as a way to speed up data collection, reporting the effective CPI of our protection mechanism as Scylla’s execution wrapper single-steps through the program’s code, decrypting instructions live. Time measurements are based on CPU cycles by reading the time-stamp counter register before and after execution. A summary of our results are shown in Figure 3. Overall, we found that Scylla incurs an average overhead of 20% for SPEC CPU2006.

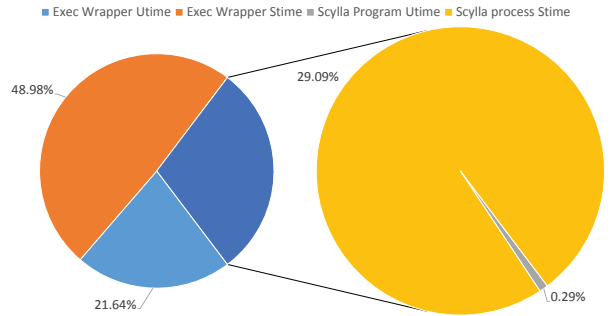

Fig. 4: Delineation of the average execution times across all SPEC CPU2006 benchmarks with execution wrapper and Scylla protected program.

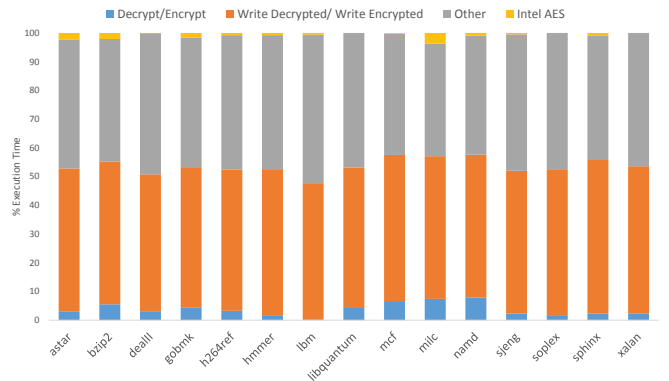

Fig. 5: Breakdown of execution times within the wrapper while managing a Scylla protected program.

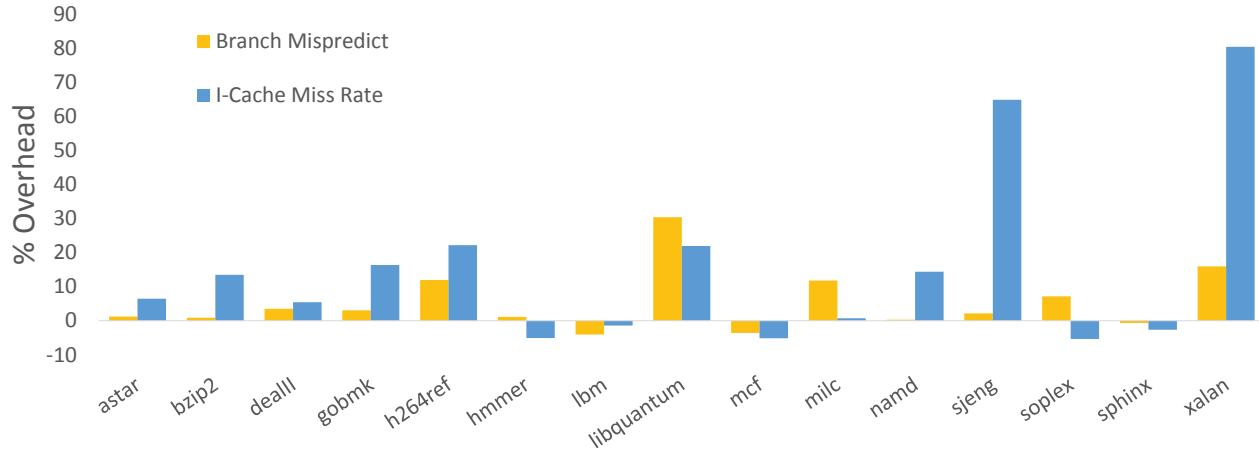

Fig. 6: Performance slowdown in Branch Misprediction and I-Cache Miss rates due to Scylla’s randomization.

**Fine Grained Diversification:** First, we evaluate the impact of code diversification by itself, computing an average overhead less than 1%. This performance result agrees with other fine-grain diversification approaches that randomize basic blocks [31]. We surmise that the performance slowdown is due to a combination of imperfect instruction cache locality because of increased code size as a result of dummy instruction insertion, or an increase in branch mispredictions due to both basic block and function permutation. Figure 6 shows the performance overhead caused by Scylla’s diversification for both branch mispredictions and the instruction cache miss rate. Branch misprediction is largely low, and in some cases improved, but on average incurs a 11% overhead. Both `libquantum` and `xalan` exhibit overheads higher than the average. `libquantum` is a library for simulating a quantum computer and contains a large number of branches, roughly 26%, so this result is expected. `xalan` is an XML processor and also contains a large number of branches compared to the other SPEC CPU2006 benchmarks, so it too experiences an increase in branch mispredictions.

From our evaluation the instruction cache miss rate suffers the most due to Scylla’s diversification. `libquantum`, `sjeng`, and `xalan` incur the highest miss rates. Both `libquantum` and `xalan` suffer from poor temporal locality due to basic block and function permutation combined with a large number of branch instructions. Prior analysis has demonstrated that the instruction cache performance is sensitive to both interpreter (`xalan`), and artificial intelligence (`sjeng`) workloads due to large code footprints that execute over a wide range of functions [45]. Overall, Scylla’s diversification causes a 25% increase in instruction cache misses across all SPEC CPU2006 benchmarks.

**Fine Grained Diversification and Instruction Encryption:**

We then evaluated Scylla’s full implementation with both code diversification and er-basic-block encryption features running within the execution wrapper. On average, the impact in

performance of Scylla incurs a 20% overhead and a worst case overhead of 22.5%.

Scylla’s prototype implementation uses a execution wrapper to monitor the encrypted process and decrypt instructions as they are scheduled to be executed. This includes reading from the encrypted child process to fetch up to a 15 byte block, generation of a 128-bit key using Intel’s AES-CM engine, decryption of the instruction, writing the decrypted instruction back into the child, executing the instruction in single-step mode using `ptrace()`, re-encrypting the instruction, and then writing the encrypted instruction back into the child. This is an simulation framework developed to model the security offered by a hardware-based implementation, which would place the decryption engine between the instruction cache and front-end of the CPU ensuring that instructions in the memory hierarchy would always remain encrypted.

Past instruction set encryption approaches have demonstrated that a hardware supported solution for runtime decryption significantly reduces this overhead [28]. As our protection does not conflict with this approach, we argue that the overhead shown in Figure 3 for both full code diversification and encryption is misleading in that it is due primarily to the execution wrapper. Figure 4 delineates the average execution times for Scylla’s full protection. Roughly 71% of the benchmark execution time is spent within the execution wrapper, 50% of which is spent within the kernel. Figure 4 also shows a broken-out plot for the child process to highlight that less than 1% of the execution time is spent executing decrypted instruction in user-land.

Figure 5 presents a breakdown of the execution times within the execution wrapper while managing the full Scylla protected program. We evaluate the time spent generating the key using Intel’s AES-CM engine, decrypting and encrypting instructions, and writing the modified instructions back into the child process. Everything else within the execution wrapper including reading from the Scylla protected program, single-

stepping the process, logging execution, and other system miscellany are included in *Other*. Our evaluation shows that key generation, decryption, and encryption represent negligible execution times, while writing decrypted and encrypted instructions back into the child process accounts for the largest observed execution time.

**Discussion:** From a hardware perspective, Scylla requires that a decryption engine decrypts instructions as they are loaded to L1 I-cache so that no plain-text instructions are resident in the shared instruction and data cache memory. A storage element is also necessary to keep the decryption secrets for basic blocks. During the execution of a process, the decryption engine is active decrypting instructions as they are loaded by the CPU. When the CPU is executing in supervisor mode, the decryption engine can remain inactive if the kernel code is not encrypted. Otherwise, a secondary decryption engine can be used for code that runs in privileged mode. During task switching, the operating system is responsible for backing up and restoring the decryption engine’s state and associated secrets. Recent research has demonstrated the feasibility of implementing this in hardware with limited additional hardware [28].

With hardware support the decryption engine would be placed in between the instruction cache and CPU front-end, ensuring that instructions would remain encrypted in the instruction cache while executing. Importantly, this would eliminate the overhead due to both writing decrypted and encrypted instructions back into the child process and overhead bundled into the category *Other*.

## IX. RELATED WORK

Previous work on prevention of code-reuse attacks can be loosely categorized into three categories: diversification, control-flow integrity, and code pointer integrity and information hiding. While each of these mechanisms raise the bar for attackers, they each have their limitations. We first discuss the merits and weaknesses of each approach using Figure 7 as a base.

**Software diversification.** Software diversification offers probabilistic protection by randomizing the program segments of an application. Code-reuse attacks are hindered by this defense because the attacker is forced to guess code locations. Diversification of program segments ranges from randomizing the base offset of code and data [14], to shuffling the location of functions [18], dynamic sections [37], basic blocks [31], [34], or instructions [36], [46]. These approaches can be applied statically at compile time or dynamically at load-time or during program execution [41], [47].

Software diversification defenses, however, are only as strong as the diversification coverage. As shown in Figure 7a, completely hiding the code layout of a program has proven difficult because there are many direct and indirect references to code locations in memory. In JIT-ROP [5], a single direct reference to a code location allowed disclosure and disassembly of a significant number of code pages with fine-grained

diversification applied to them. This technique was later shown to be applicable using indirect code pointers [41].

**Control-flow Integrity (CFI).** CFI is a general defense against code-reuse attacks [26] that mitigates control-flow hijacking by constraining execution to a legitimate control-flow path. It does so by checking that each control-flow transfer targets a valid code location as determined by the program’s control-flow graph (CFG). The accuracy of the statically, or dynamically, computed CFG determines the precision of the CFI policy. This largely determines the granularity with which control-flow checks can be made and the policy’s resilience to attack.

CFI solutions in software, however, typically relax the CFG coverage in favor of performance resulting in so-called coarse-grained CFI [42], [20]. Previous work has demonstrated that relaxation of CFG coverage leaves an application susceptible to attack [38], [12], [43]. Figure 7b illustrates this point. The runtime address for the register-indirect call cannot be computed statically, therefore the policy has instrumented all targets with the same checking routine. An adversary can redirect control to any checking routine with the same semantics; per Figure 7b to any target that checks label A. Recent work also calls into question the protection offered by ideally fine-grained CFI defenses, e.g., a CFI policy supported by a completely precise CFG, using a technique called control-flow bending [9].

**Code-Pointer Integrity (CPI) and Information Hiding.** CPI and information hiding defenses prevent writing or reading to sensitive memory regions. This ranges from hiding code pointers in safe memory with strict access control [25], to hiding them behind access permissions [48], [18]. This defense affords attackers limited knowledge of the vulnerable application’s address space layout and limits arbitrary manipulation of code pointers. A recent approach [22], called execute-no-read (XnR) delimits access permission on code pages, marking them as executable-only. A hardware supported version of this defense successfully mitigates a wide-range of CRAs that rely on direct or indirect memory disclosure. Its software implementation, however, is still susceptible to attack [49].

Much like software diversity and CFI, information hiding has been shown to be vulnerable to attack. Figure 7c illustrates a general approach to bypassing information hiding. An adversary first gains control of an arbitrary read or write vulnerability, which then is used to find and corrupt hidden regions. Later references to the corrupted portions of hidden memory result in unchecked control-flow hijacking because the system assumes dereferencing code pointers from the hidden region is safe. JIT-ROP [5] was shown to successfully bypass Oxymoron [48], a defense that hides direct code pointers using Intel’s segment selector registers, by leaking indirect code pointers on virtual tables. An attack was also demonstrated against CPI by leaking its safe memory region using timing side-channels [13].

**Related Approaches.** Besides instruction-set randomization (see Section II), another work that bears some resemblance

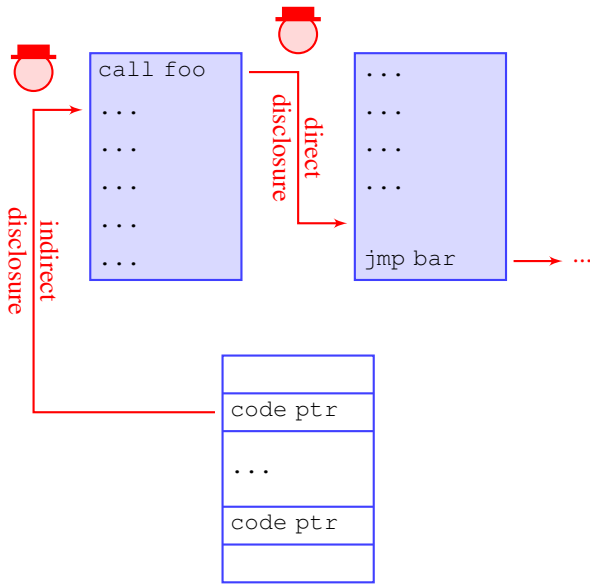

(a) Using both direct and indirect disclosures, software diversity approaches can be bypassed.

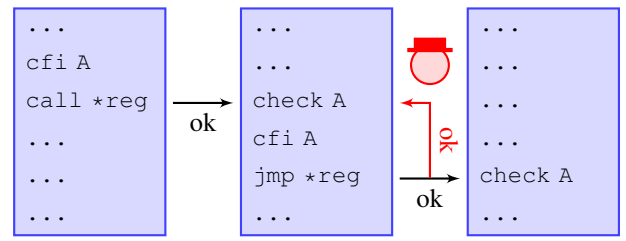

(b) Relaxations in the policy make CFI approaches bypassable.

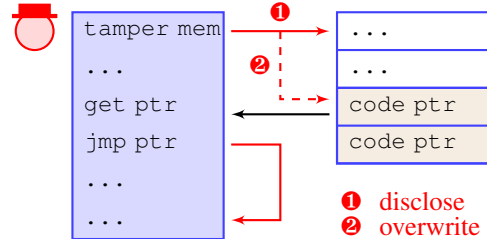

(c) Information hiding relies on the separation of code pointers from regular data. Disclosing this area of memory makes the approach bypassable.

Fig. 7: Different defense mechanisms against code reuse attacks and their bypasses. In this figure, pages shaded as   are marked as readable and executable. Pages shaded as   are flagged as readable and writable. Pages shaded as   are hidden from the attacker, but readable and writable.

to ours is Isomeron [41]. Isomeron tolerates complete code memory disclosure using clones (isomers) of functions within a program. A cloned function is first diversified and then, on each control-flow instruction, a “coin-flip” decides which control-flow target will be executed, the original or clone. As the attacker is unaware of which code will execute, crafting a control-flow hijacking attack becomes unreliable. In that work, it is mentioned that combining ISR with diversification incurs an unacceptable overhead. However, we have shown that the runtime overhead of our approach is similar on average to Isomeron, which incurs a 19% performance increase on average. As we have demonstrated, the main contribution to the overhead of our system is due to the execution wrapper, which is a prototype implementation. With full hardware decryption support, we would incur overhead due mainly to our code diversification protection. We also protect against a larger class of CRAs [5], [9], [6] than Isomeron.

A recent diversification approach from Crane et al. [18], called Readactor, protects applications from direct and indirect memory disclosure by combining fine-grained diversity with code-pointer hiding and execute-no-read (XnR) protection. They achieve a practical runtime overhead of only 6.4% and demonstrate a working implementation by protecting the entire Google Chromium browser and its V8 JIT compiler. Our work shares many similarities, in particular we incorporate fine-grained code diversification and support code hiding techniques using encryption of code pages. While we incur a higher overhead, a key feature of our work, as opposed to Readactor, is its resilience to CROP [6] style attacks that infer code locations using crash-resistant memory oracles. As discussed in Section VI, our approach withstands such an

attack as it is infeasible to disclose the plaintext and construct a reliable payload under our code diversification and key permutation scheme even if an adversary has knowledge of code locations.

## X. CONCLUSION

In this paper, we introduce *Scylla*, the first hybrid defense incorporating software diversity, control-flow integrity, and information hiding. We demonstrate how an encryption chain over basic blocks can be used to achieve *execution integrity*. When combined with software diversification techniques and information hiding, *Scylla*’s per-basic-block encryption yields a mechanism that is capable of protecting against a diverse set of code-reuse attacks under a powerful attacker model. We also show the applicability of our mechanism to a multitasking system while demonstrating reasonable performance overhead when benchmarked with the SPEC CPU2006 suite.

## REFERENCES

- [1] G. S. Kc, A. D. Keromytis, and V. Prevelakis, “Countering code-injection attacks with instruction-set randomization,” in *Proceedings of the 10th ACM conference on Computer and communications security*. ACM, 2003, pp. 272–280.
- [2] E. G. Barrantes, D. H. Ackley, T. S. Palmer, D. Stefanovic, and D. D. Zovi, “Randomized instruction set emulation to disrupt binary code injection attacks,” in *Proceedings of the 10th ACM conference on Computer and communications security*. ACM, 2003, pp. 281–289.
- [3] S. W. Boyd, G. S. Kc, M. E. Locasto, A. D. Keromytis, and V. Prevelakis, “On the general applicability of instruction-set randomization,” *Dependable and Secure Computing, IEEE Transactions on*, vol. 7, no. 3, pp. 255–270, 2010.
- [4] G. Portokalidis and A. D. Keromytis, “Fast and practical instruction-set randomization for commodity systems,” in *Proceedings of the 26th Annual Computer Security Applications Conference*. ACM, 2010, pp. 41–48.

- [5] K. Z. Snow, F. Monrose, L. Davi, A. Dmitrienko, C. Liebchen, and A.-R. Sadeghi, "Just-in-time code reuse: On the effectiveness of fine-grained address space layout randomization," in *Security and Privacy (SP), 2013 IEEE Symposium on*. IEEE, 2013, pp. 574–588, received the Best Student Paper Award.
- [6] R. Gawlik, B. Kollenda, P. Koppe, B. Garmany, and T. Holz, "Enabling client-side crash-resistance to overcome diversification and information hiding," *Symposium on Network and Distributed System Security (NDSS)*, 2016, to Appear.
- [7] A. Bittau, A. Belay, A. Mashtizadeh, D. Mazieres, and D. Boneh, "Hacking blind," in *Security and Privacy (SP), 2014 IEEE Symposium on*. IEEE, 2014, pp. 227–242.
- [8] I. Evans, F. Long, U. Otgonbaatar, H. Shrobe, M. Rinard, H. Okhravi, and S. Sidiroglou-Douskos, "Control jujutsu: On the weaknesses of fine-grained control flow integrity," in *Proceedings of the 22nd ACM SIGSAC Conference on Computer and Communications Security*. ACM, 2015, pp. 901–913.
- [9] N. Carlini, A. Barresi, M. Payer, D. Wagner, and T. R. Gross, "Control-flow bending: On the effectiveness of control-flow integrity," in *24th USENIX Security Symposium (USENIX Security 15)*, 2015, pp. 161–176.
- [10] M. Conti, S. Crane, L. Davi, M. Franz, P. Larsen, M. Negro, C. Liebchen, M. Qunaibit, and A.-R. Sadeghi, "Losing control: On the effectiveness of control-flow integrity under stack attacks," in *Proceedings of the 22nd ACM SIGSAC Conference on Computer and Communications Security*. ACM, 2015, pp. 952–963.
- [11] F. Schuster, T. Tendyck, C. Liebchen, L. Davi, A.-R. Sadeghi, and T. Holz, "Counterfeit object-oriented programming: On the difficulty of preventing code reuse attacks in c++ applications," in *Security and Privacy (SP), 2015 IEEE Symposium on*. IEEE, 2015, pp. 745–762.
- [12] E. Goktas, E. Athanasopoulos, H. Bos, and G. Portokalidis, "Out of control: Overcoming control-flow integrity," in *Security and Privacy (SP), 2014 IEEE Symposium on*. IEEE, 2014, pp. 575–589.
- [13] I. Evans, S. Fingeret, J. González, U. Otgonbaatar, T. Tang, H. Shrobe, S. Sidiroglou-Douskos, M. Rinard, and H. Okhravi, "Missing the point (er): On the effectiveness of code pointer integrity," in *Security and Privacy (SP), 2015 IEEE Symposium on*. IEEE, 2015, pp. 781–796.
- [14] P. Team, "Pax address space layout randomization (aslr)," 2003.
- [15] C. Lattner and V. Adve, "Llvm: A compilation framework for lifelong program analysis & transformation," in *Code Generation and Optimization, 2004. CGO 2004. International Symposium on*. IEEE, 2004, pp. 75–86.
- [16] Microsoft, "Enhanced mitigation experience toolkit," <https://www.microsoft.com/emeti>.
- [17] C. Giuffrida, A. Kuijsten, and A. S. Tanenbaum, "Enhanced operating system security through efficient and fine-grained address space randomization," in *Presented as part of the 21st USENIX Security Symposium (USENIX Security 12)*, 2012, pp. 475–490.
- [18] S. Crane, C. Liebchen, A. Homescu, L. Davi, P. Larsen, A.-R. Sadeghi, S. Brunthaler, and M. Franz, "Readactor: Practical code randomization resilient to memory disclosure," in *IEEE Symposium on Security and Privacy, S&P*, vol. 15, 2015.
- [19] K. Lu, C. Song, B. Lee, S. P. Chung, T. Kim, and W. Lee, "Asr-guard: Stopping address space leakage for code reuse attacks," in *Proceedings of the 22nd ACM SIGSAC Conference on Computer and Communications Security*. ACM, 2015, pp. 280–291.
- [20] C. Zhang, T. Wei, Z. Chen, L. Duan, L. Szekeres, S. McCamant, D. Song, and W. Zou, "Practical control flow integrity and randomization for binary executables," in *Security and Privacy (SP), 2013 IEEE Symposium on*. IEEE, 2013, pp. 559–573.
- [21] C. Tice, T. Roeder, P. Collingbourne, S. Checkoway, Ú. Erlingsson, L. Lozano, and G. Pike, "Enforcing forward-edge control-flow integrity in gcc & llvm," in *USENIX Security Symposium*, 2014.
- [22] M. Backes, T. Holz, B. Kollenda, P. Koppe, S. Nürnberger, and J. Pevny, "You can run but you can't read: Preventing disclosure exploits in executable code," in *Proceedings of the 2014 ACM SIGSAC Conference on Computer and Communications Security*. ACM, 2014, pp. 1342–1353.
- [23] J. Gionta, W. Enck, and P. Ning, "Hidem: Protecting the contents of userspace memory in the face of disclosure vulnerabilities," in *Proceedings of the 5th ACM Conference on Data and Application Security and Privacy*. ACM, 2015, pp. 325–336.
- [24] A. Tang, S. Sethumadhavan, and S. Stolfo, "Heisenbyte: Thwarting memory disclosure attacks using destructive code reads," in *Proceedings of the 22nd ACM SIGSAC Conference on Computer and Communications Security*. ACM, 2015, pp. 256–267.
- [25] V. Kuznetsov, L. Szekeres, M. Payer, G. Candea, R. Sekar, and D. Song, "Code-pointer integrity," in *USENIX Symposium on Operating Systems Design and Implementation (OSDI)*, 2014.
- [26] M. Abadi, M. Budiu, U. Erlingsson, and J. Ligatti, "Control-flow integrity," in *Proceedings of the 12th ACM Conference on Computer and Communications Security*, ser. CCS '05, 2005. [Online]. Available: <http://doi.acm.org/10.1145/1102120.1102165>
- [27] A. N. Sorel, D. Evans, and N. Paul, "Where's the feeb? the effectiveness of instruction set randomization," in *Usenix Security*, 2005.
- [28] A. Papadogiannakis, L. Loutsis, V. Papaefstathiou, and S. Ioannidis, "Asist: architectural support for instruction set randomization," in *Proceedings of the 2013 ACM SIGSAC conference on Computer & communications security*. ACM, 2013, pp. 981–992.
- [29] S. Andersen and V. Abella, "Data execution prevention. changes to functionality in microsoft windows xp service pack 2, part 3: Memory protection technologies," 2004.
- [30] C. Kil, J. Jun, C. Bookholt, J. Xu, and P. Ning, "Address space layout permutation (aslp): Towards fine-grained randomization of commodity software," in *null*. IEEE, 2006, pp. 339–348.
- [31] R. Wartell, V. Mohan, K. W. Hamlen, and Z. Lin, "Binary stirring: Self-randomizing instruction addresses of legacy x86 binary code," in *Proceedings of the 2012 ACM conference on Computer and communications security*. ACM, 2012, pp. 157–168.
- [32] T. Jackson, A. Homescu, S. Crane, P. Larsen, S. Brunthaler, and M. Franz, "Diversifying the software stack using randomized nop insertion," in *Moving Target Defense II*. Springer, 2013, pp. 151–173.
- [33] K. Onarlioglu, L. Bilge, A. Lanzi, D. Balzarotti, and E. Kirda, "G-free: defeating return-oriented programming through gadget-less binaries," in *Proceedings of the 26th Annual Computer Security Applications Conference*. ACM, 2010, pp. 49–58.
- [34] L. V. Davi, A. Dmitrienko, S. Nürnberger, and A.-R. Sadeghi, "Gadge me if you can: secure and efficient ad-hoc instruction-level randomization for x86 and arm," in *Proceedings of the 8th ACM SIGSAC symposium on Information, computer and communications security*. ACM, 2013, pp. 299–310.
- [35] J. L. Henning, "Spec cpu2006 benchmark descriptions," *ACM SIGARCH Computer Architecture News*, vol. 34, no. 4, pp. 1–17, 2006.
- [36] J. Hiser, A. Nguyen-Tuong, M. Co, M. Hall, and J. W. Davidson, "Ilr: Where'd my gadgets go?" in *Security and Privacy (SP), 2012 IEEE Symposium on*. IEEE, 2012, pp. 571–585.
- [37] S. J. Crane, S. Volckaert, F. Schuster, C. Liebchen, P. Larsen, L. Davi, A.-R. Sadeghi, T. Holz, B. De Sutter, and M. Franz, "It's a trap: Table randomization and protection against function-reuse attacks," in *Proceedings of the 22nd ACM SIGSAC Conference on Computer and Communications Security*. ACM, 2015, pp. 243–255.
- [38] S. Checkoway, L. Davi, A. Dmitrienko, A.-R. Sadeghi, H. Shacham, and M. Winandy, "Return-oriented programming without returns," in *Proceedings of the 17th ACM conference on Computer and communications security*. ACM, 2010, pp. 559–572.
- [39] T. Bletsch, X. Jiang, V. W. Freeh, and Z. Liang, "Jump-oriented programming: A new class of code-reuse attack," in *Proceedings of the 6th ACM Symposium on Information, Computer and Communications Security*, ser. ASIACCS '11, 2011, pp. 30–40.
- [40] H. Shacham, "The geometry of innocent flesh on the bone: Return-into-libc without function calls (on the x86)," in *Proceedings of the 14th ACM Conference on Computer and Communications Security*, ser. CCS'07, 2007. [Online]. Available: <http://doi.acm.org/10.1145/1315245.1315313>
- [41] L. Davi, C. Liebchen, A.-R. Sadeghi, K. Z. Snow, and F. Monrose, "Isomeron: Code randomization resilient to (just-in-time) return-oriented programming," *Proc. 22nd Network and Distributed Systems Security Sym.(NDSS)*, 2015.
- [42] M. Zhang and R. Sekar, "Control flow integrity for cots binaries." in *Usenix Security*, vol. 13, 2013.
- [43] L. Davi, A.-R. Sadeghi, D. Lehmann, and F. Monrose, "Stitching the gadgets: On the ineffectiveness of coarse-grained control-flow integrity protection," in *23rd USENIX Security Symposium (USENIX Security 14)*, 2014, pp. 401–416.
- [44] N. Carlini and D. Wagner, "Rop is still dangerous: Breaking modern defenses," in *23rd USENIX Security Symposium (USENIX Security 14)*, 2014, pp. 385–399.

- [45] A. Jaleel, "Memory characterization of workloads using instrumentation-driven simulation," *Web Copy: [http://www. glue. umd. edu/ajaleel/workload](http://www.glue.umd.edu/ajaleel/workload)*, 2010.
- [46] V. Pappas, M. Polychronakis, and A. D. Keromytis, "Smashing the gadgets: Hindering return-oriented programming using in-place code randomization," in *Security and Privacy (SP), 2012 IEEE Symposium on*. IEEE, 2012, pp. 601–615.
- [47] D. Bigelow, T. Hobson, R. Rudd, W. Streilein, and H. Okhravi, "Timely rerandomization for mitigating memory disclosures," in *Proceedings of the 22nd ACM SIGSAC Conference on Computer and Communications Security*. ACM, 2015, pp. 268–279.
- [48] M. Backes and S. Nürnberger, "Oxymoron: Making fine-grained memory randomization practical by allowing code sharing," in *USENIX Security Symposium*, 2014.
- [49] J. Werner, G. Baltas, R. Dallara, N. Otterness, K. Z. Snow, F. Monrose, and M. Polychronakis, "No-execute-after-read: Preventing code disclosure in commodity software," in *Proceedings of the 11th ACM on Asia Conference on Computer and Communications Security*. ACM, 2016, pp. 35–46.